



ENTERPRISE BLUETOOTH LOCK



Installation & User Manual

Model: RBDB01

www.RentlyBlue.com

The Rently BLUE access control system provides cutting edge bluetooth lock technology at a cost effective price point.

Managers that incorporate Rently Blue on a property can instantly provide access to prospective renters, guests and vendors without the need for keys.

Renters that move into a Rently Blue property get a beautiful keyless entry bluetooth lock and eliminate keys...for good!



Easy Install | Replace your existing “dumb” lock with a state of the art smart bluetooth lock in minutes.



Eliminate Keys! | Replace your keys with unique codes to easily provide property access.



Digital Keys | Instantly issue durational digital bluetooth “keys” to guests or maintenance.



Self-Showing | Instantly activate Rently.com self-showing technology on vacant properties. Visit www.rently.com to learn more.



Low Battery Alert | Get notified when batteries run low. Replace with 4 standard AA batteries.



Activity Log | Using the app, download activity and access logs to your phone.

Installation





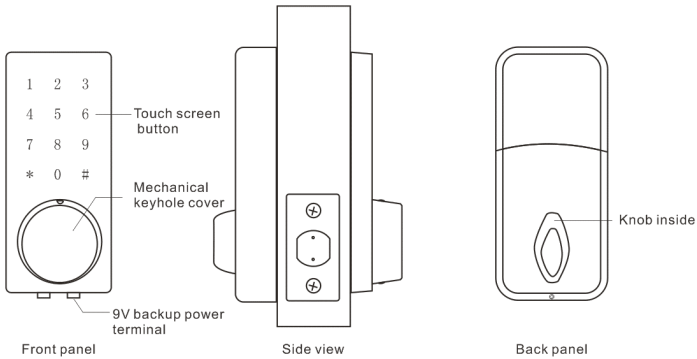
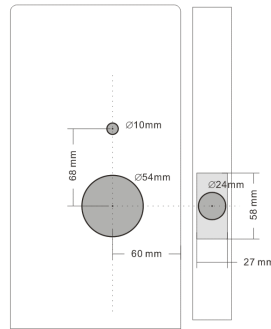
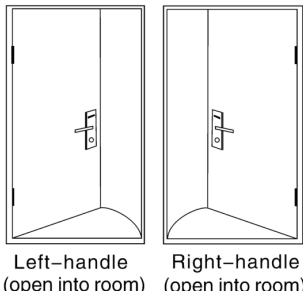

Please ensure that door specifications meet the below listed requirements. A keyless passage knob may be required for doors with two bore holes.

- Door frame - 4.3" inches (110mm)
- Door thickness: 1.5"-1.88" inches (38-48mm)
- To install the lock for right side handling, ensure the toggle button on the back assembly is set to L.
- To install the lock for left side handling, ensure the toggle button on the back assembly is set to R.

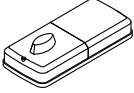
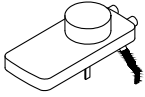

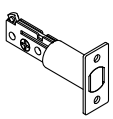
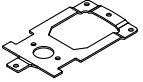
Communication Protocol	Bluetooth 4.0 BLE
Locking	BLE, Code, Key
Devices Supported	Android 4.3, iOS 7.0 and above
Power Supply	4 AA batteries
Current	Static <30uA, Working 200ma

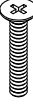
Installation (Continued)

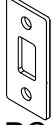
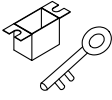
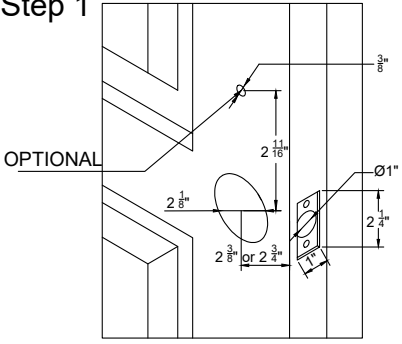
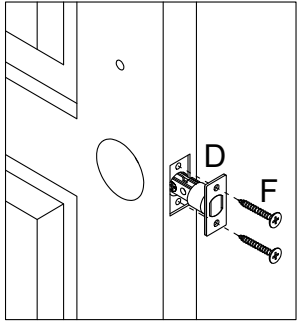
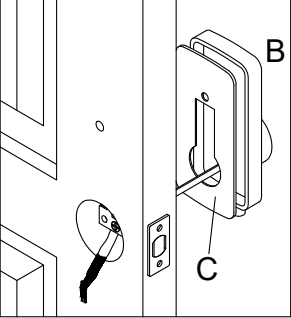
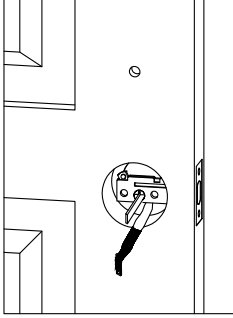
<p>A</p>  <p>1PC</p>	<p>B</p>  <p>1PC</p>	<p>C</p>  <p>1PC</p>	<p>D</p>  <p>1PC</p>	<p>E</p>  <p>1PC</p>		
<p>F</p>  <p>4PCS</p>	<p>G</p>  <p>2PCS</p>	<p>H</p>  <p>1PC</p>	<p>I</p>  <p>2PCS</p>	<p>J</p>  <p>1PC</p>	<p>K</p>  <p>1PC</p>	
<p>Step 1</p> 			<p>Step 2</p> 			
<p>Step 3</p> 			<p>Step 4</p> 			

Installation (Continued)

Step 5

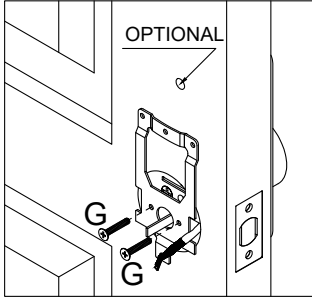

Step 6

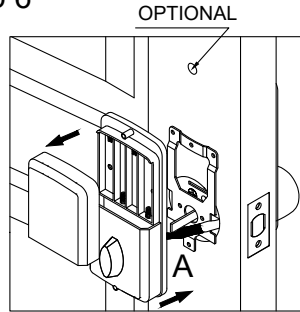

Step 7

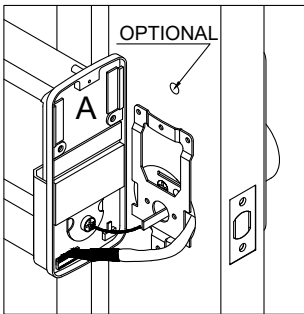

Step 8

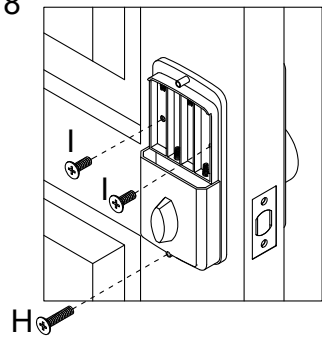

Step 9

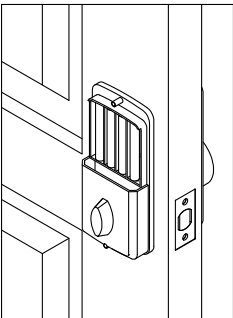

Step 10

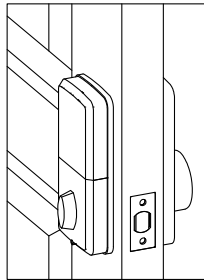

Step 11

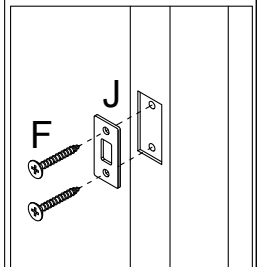

Self-Showing

To activate Rently self-showing for vacant properties, login to www.rently.com with your manager credentials.

Locking

Touchscreen: Press and Hold # button until deadbolt engages.

App: Engage Auto-lock function in menu after pairing lock.

Unlocking

Key: to unlock, remove deadbolt cover and insert key. Rotate key counter clockwise until deadbolt disengages.

Code: to unlock, type in code followed by # key.

App: After pairing lock, select lock, tap Unlock. Ensure you are within 10 feet of lock.

Pairing

Pairing Rently Blue allows managers to hand off access to Blue to residents, issue e-keys, audit access logs, and app unlock.

1. Download the Rently Blue App.
2. Register a new account or login with an existing account.
3. Turn on Bluetooth on mobile device. Open Rently Blue App and Select "Pair" from menu.
4. After mobile phone and Rently Blue are paired, click menu to operate lock.

FCC Statement

This device complies with part 15 of the FCC Rules. Operation is subject to the following two conditions: (1) This device may not cause harmful interference, and (2) this device must accept any interference received, including interference that may cause undesired operation. This equipment has been tested and found to comply with the limits for a Class B digital device, pursuant to part 15 of the FCC Rules. These limits are designed to provide reasonable protection against harmful interference in a residential installation. This equipment generates, uses and can radiate radio frequency energy and, if not installed and used in accordance with the instructions, may cause harmful interference to radio communications.

However, there is no guarantee that interference will not occur in a particular installation. If this equipment does cause harmful interference to radio or television reception, which can be determined by turning the equipment off and on, the user is encouraged to try to correct the interference by one or more of the following measures: Reorient or relocate the receiving antenna. Increase the separation between the equipment and receiver. Connect the equipment into an outlet on a circuit different from that to which the receiver is connected. Consult the dealer or an experienced radio/TV technician for help.

§ 15.21 Information to user.

The users manual or instruction manual for an intentional or unintentional radiator shall caution the user that changes or modifications not expressly approved by the party responsible for compliance could void the user's authority to operate the equipment. In cases where the manual is provided only in a form other than paper, such as on a computer disk or over the Internet, the information required by this section may be included in the manual in that alternative form, provided the user can reasonably be expected to have the capability to access information in that form.