

PREPARED BY: Irina Shmagin	 PROPRIETARY INFORMATION NO DISSEMINATION OR USE ALLOWED WITHOUT PRIOR WRITTEN PERMISSION	DOCUMENT NUMBER:
APPROVALS:		REVISION: 5.0
		DATE: 07/14/2008
		PAGE 1 OF 8
		DOCUMENT TYPE Users Manual

User's Guide for GNAD1A GSM Module

Document No.: Error! Reference source not found.	Title: User Guide for GNAD1A GSM module	
Continental Automotive Systems	Date: 07/14/2008	Page: 2

1. INTRODUCTION	3
1.1 <u>DOCUMENT CHANGES</u>	3
2. OVERVIEW	3
2.1 <u>GENERAL</u>	3
2.2 <u>GNAD1A DESCRIPTION</u>	3
2.3 <u>TEST SET-UP DESCRIPTION</u>	4
2.4 <u>QUICK START COMMUNICATION GUIDE</u>	5
2.5 <u>QUICK START CALL GUIDE</u>	5
2.6 <u>LIST OF SUPPORTED AT COMMANDS FOR TESTING PURPOSES</u>	6
2.7 <u>FCC NOTE</u>	8
2.8 <u>CERTIFICATION TESTING GUIDE</u>	9
2.8.1 <i>Smart Card Features (SIM ME)</i>	9
2.8.2 <i>EONS Test Cases</i>	9
2.8.3 <i>Call Processing</i>	10
2.8.4 <i>Network Selection</i>	10
2.8.5 <i>UICC-OTA for MSISDN update</i>	10
2.8.6 <i>Enhanced Network Selection (ENS)</i>	10

TABLE OF FIGURES:

<i>Figure 1: Diagram of GNAD1A GSM Module</i>	4
<i>Figure 2: Photograph of GNAD1A GSM Module</i>	4
<i>Figure 3: Assembled test set-up for GMAD1A functional testing</i>	5

Document No.: Error! Reference source not found.	Title: User Guide for GNAD1A GSM module	
Continental Automotive Systems	Date: 07/14/2008	Page: 3

1. Introduction

1.1 Document changes

Revision	Description	Date
1.0	Initial draft	1/30/07
2.0	Updated Version	04/29/2008
5.0	Updated Version	07/14/2008

2. Overview

2.1 General

GNAD1A is a proprietary GSM/GPRS/EDGE module from Continental Automotive Systems. The module will be integrated into telecommunication control devices produced by Continental for its automotive customers.

The GAND1A test set-up is available for third-party testing which do not require audio or data-logging capabilities. This document will provide description for the test set-up.

2.2 GNAD1A Description

GNAD1A is a proprietary GSM module designed and manufactured by Continental Automotive Systems for use in automotive applications. The key features of the modules are:

- Quad-band GSM/GPRS/EDGE
- GPRS and EDGE Class 10
- 5 V DC Input
- 250-450 mA average current draw while in a call
- Up to 3 A peak current during GSM burst
- Fakra RF connectors
- Primary (black) and Secondary (maroon) RF antenna connectors
- On-board SIM card connector for 3 V SIM cards
- 40-pin system-level connector
- PCM audio
- Primary UART with auto baud rate detection up to 115.2 Kbps. Max supported rate is 921.6 Kbps.

A diagram of the GNAD1A GSM module is shown in Figure 1. A photograph of the GNAD1A module is shown in Figure 2.

Document No.: Error! Reference source not found.	Title: User Guide for GNAD1A GSM module	
Continental Automotive Systems	Date: 07/14/2008	Page: 4

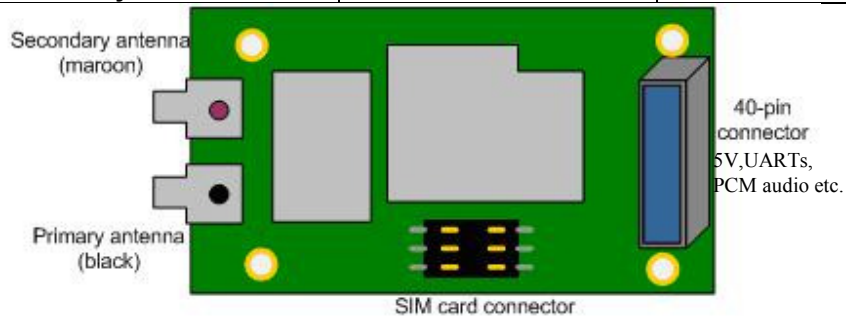

Figure 1: Diagram of GNAD1A GSM Module

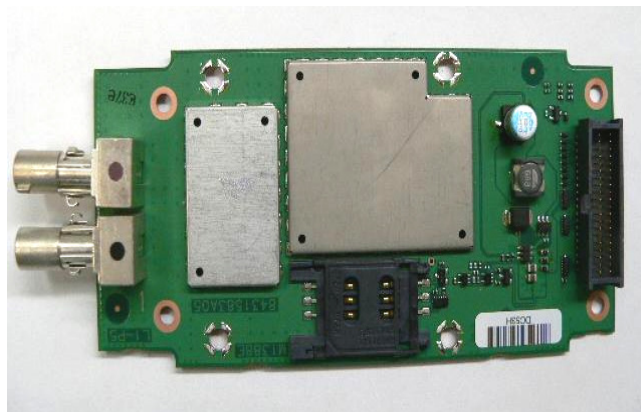

Figure 2: Photograph of GNAD1A GSM Module

2.3 Test Set-up Description

This set-up includes:

- 5V Battery Input Connector
- 40 pin connector to connect to GNAD1A
- On/Off Bounce Button for NAD_ON_OFF power
- RS232 communication with the primary UART (default baud rate 57.6Kbits)
- On-OFF Switch
- AT commands control

An assembled test set-up is shown in Figure 3:

Document No.: Error! Reference source not found.	Title: User Guide for GNAD1A GSM module	
Continental Automotive Systems	Date: 07/14/2008	Page: 5

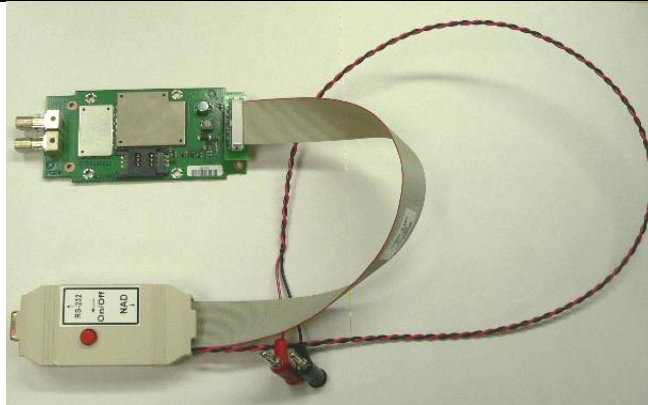

Figure 3. Assembled test set-up for GNAD1A functional testing

2.4 Quick Start Communication Guide

In order to communicate from a laptop to the GNAD1A (as shown in Figure 3), the following equipment is needed:

- Laptop PC
- Interface board
- 5V DC Power supply (2 Amp)
- GNAD1A
- Serial Port Cable
- HyperTerminal, Hyper Access or another Communication tool For use with HyperTerminal baud rate needs to be set to 57.6Kbits, 8 bits, no parity, no stop bits, and hardware flow control.

The following procedure should be followed to communicate with the GNAD1A:

- 1) Set the power supply to 5.0V and the current limit to 2.0A.
- 2) Connect the interface board to the power supply
- 3) Connect the serial port cable to the COM1 of PC and to the RS-232 connection on the Interface board.
- 4) Turn on the power supply output.
- 5) Press the NAD_ON_OFF switch for 3 seconds. The module should power on.
- 6) Use the primary UART to communicate with the NAD using HyperTerminal, Hyperaccess etc. "READY" message will appear when module powers on.
- 7) To turn the NAD off, press and hold the NAD_ON_OFF switch again for 2 seconds.

2.5 Quick Start Call Guide

After setting up the interface board and GNAD1A as discussed in 2.4, the following AT commands can be sent to the NAD using HyperTerminal to make a call:

- 1) Type AT to confirm communication should receive OK back.(optional)

Document No.: Error! Reference source not found.	Title: User Guide for GNAD1A GSM module	
Continental Automotive Systems	Date: 07/14/2008	Page: 6

- 2) The module is pre-set to use primary (black) antenna. Type AT+TASW= 1 (primary) or AT+TASW=2 (secondary) for antenna selection.
- 3) The radio will start scanning automatically on power-up with an unlocked SIM.
- 4) Type AT+XBANDSEL=NUM (where NUM is 850, 900, 1800, 1900 or 0 for all bands) to set the band of operation if desired (optional).
- 5) Type ATD123456; to make a voice call.
- 6) To end the call type ATH

Data calls are not discussed here but standard AT commands apply.

2.6 List of Supported AT commands for testing purposes

The section lists AT commands supported by GNAD1A. Unless otherwise noted, the AT commands shall follow the syntaxes specified in GSM 07.07. See AT Command manual for more information.

AT COMMAND	FUNCTION
+CACM	Accumulated Call Meter
+CAMP	Accumulated Call Meter Maximum
+CAOC	Advice of Charge
+CBM	Cell Broadcast Message Receipt
+CBST	Selecting Bearer Service Type
+CCFC	Call Forwarding
+CCLK	System Date and Time
+CCWA	Call Waiting
+CDSI	SMS Status Report Receipt
+CEER	Extended Error Report
+CGACT	PDP Context Activate or Deactivate
+CGATT	GPRS Attach or Detach
+CGDCONT	Define PDP Context
+CGEREP	GPRS Event Reporting
+CGMI	Request Manufacturer ID
+CGMM	Request Model ID
+CGMR	Request Revision
+CGQMIN	Quality of Service (Minimum Accepted)
+CGQREQ	Quality of Service (Requested)
+CGREG	GPRS Network Registration Status
+CGSN	Request Serial Number
+CHLD	Supplementary Call Control
+CHUP	Hang up Call
+CIEV	Event Notifications
+CIMI	Request IMSI
+CIND	Indicator Control

Document No.: Error! Reference source not found.	Title: User Guide for GNAD1A GSM module	
Continental Automotive Systems	Date: 07/14/2008	Page: 7

+CLAN	Set Language
+CLCC	List Current Calls
+CLCK	Facility Lock
+CLIP	Calling Line Identification (Caller ID)
+CLIR	Calling Line Identification Restriction
+CME	ERROR Extended Error Report
+CMEE	Extended Error Reporting
+CMER	Event Reporting
+CMGD	Delete SMS Message
+CMGF	Message Format
+CMGL	List SMS Messages
+CMGR	Read SMS Messages
+CMGS	Send SMS Message
+CMGW	Write Message to Memory
+CMS	ERROR SMS Message Service Failure Result Code
+CMSS	Send Message from Storage
+CMTI	SMS Message Receipt
+CMUX	GSM07.10 Multiplexer
+CNMI	New Message Indications
+CNUM	Request MSIDSN
+COLP	Connected Line Identification
+COPS	Operator Selection
+CPBF	Find Phonebook Entry
+CPBR	Read Phonebook
+CPBS	Phonebook Select
+CPBW	Write and Delete Phonebook Entry
+CPIN	SIM PIN Control
+CPMS	Preferred Message Storage
+CPOL	Preferred Operator List
+CPWD	Change Password
+CRC	Cellular Result Code
+CREG	Network Registration
+CRING	Incoming Call Notification
+CRSM	Request SIM Information
+CSCA	Service Center Address
+CSCB	Select Cell Broadcast Message Types
+CSCS	Set/Request Character Set
+CSDH	Text Mode Parameters
+CSMS	Select Message Service
+CSQ	Signal Quality
+GMI	Request Manufacturer ID
+GMM	Request Model ID

Document No.: Error! Reference source not found.	Title: User Guide for GNAD1A GSM module	
Continental Automotive Systems	Date: 07/14/2008	Page: 8

+GMR	Request Revision
+IPR	Baud Rate (Persistent)
+VTD	Default DTMF Tone Duration
+VTS	Send DTMF Tone
&F	Return to Factory Default
A	Answer Incoming Call
CONNECT	Connection Notification
D	Dial
H	Hang up Call
NO CARRIER	Connection Failure Notification
O	Switch to Online Data Mode
RING	Incoming Call Notification
S0	Automatic Answer
S7	Connection Completion Timeout

Telematics Specific Commands

AT COMMAND	FUNCTION
READY	NAD Power Up Unsolicited Response
+CBAUD	Baud Rate (Temporary)
+TADIAG	Antenna Diagnostics
+TASW	Antenna Switch
+TPIN	Remaining SIM PIN/PUK Attempts
READY	Power Up Unsolicited Response

2.7 FCC Note

This device complies with Part 15 of the FCC Rules. The FCC ID for this device is **LHJGNAD1A**. Operation is subject to the following two conditions:

1. This device may not cause harmful interference.
2. This device must accept any interference received, including interference that may cause undesired operation.

Changes or modifications to this system by other than an authorized service facility could void authorization to use this equipment.

Please note that if the GNAD1A module is integrated into a host device, second label must be placed on the outside of the final device that contains the following text: "**Contains FCC ID: LHJGNAD1A**".

The GNAD1A module is offered for use with an external antenna which is not specified by Continental Automotive Systems. The intended use-case for the device is with a vehicle roof-top antenna. The antenna(s) which are used for the transmitter must be installed to provide a separation distance of at least 20cm from all persons and must not be co-located or operating in

Document No.: Error! Reference source not found.	Title: User Guide for GNAD1A GSM module	
Continental Automotive Systems	Date: 07/14/2008	Page: 9

conjunction with any other antenna or transmitter. The following are the guidelines for the maximum antenna gain which should be used for selecting an external antenna:

- For the 850 MHz band the maximum antenna gain is -1.24 dBd
- For the 1900 MHz band the maximum antenna gain is 7.8 dBi

The maximum gain of the antenna path (cable loss + antenna gain) shall not exceed the above mentioned values.

2.8 Certification Testing Guide

This section is designed to provide specific command to be used during certification testing.

2.8.1 Smart Card Features (SIM ME)

- Verify Deletion of a Smart Card Based Contact
Use **AT+CPBS** to select directory and **AT+CPBW=6,"",,""** to delete location.
- Verify the terminal supports calling from the smart card contacts list.
Use **ATD>#;** (#) is preset number.
- Verify Deletion of an FDN entry
Use **AT+CPBW=6,"",,""** to delete location.
- Verify Allowed MO Calls
Makes calls, No pause dialing and no spaces
- Verify Disallowed MO Calls
Use **AT+CEER** to get message that says "**CC setup error,279,FDNfailed**"
- Verify Disallowed Calling from the Smart Card Contact List, LND and SDN Phonebooks
Use **AT+CEER** to get message that says "**CC setup error,279,FDNfailed**"
- Verify PIN1 Changing Procedure
Use Command **AT+CPWD=<fac>,<oldpwd>,<newpwd>**
- Verify PIN1 Blocking Behavior at Power Up
Use **AT+XPINCNT** gives count of attempts left on each Pin
- Verify PIN2 Changing Procedure
Use **AT+CPWD="P2", "<old pin2>", "<new pin2>"**
- Verify Display of Initial MSISDNs
Use **AT+CNUM**

2.8.2 EONS Test Cases

Document No.: Error! Reference source not found.	Title: User Guide for GNAD1A GSM module	
Continental Automotive Systems	Date: 07/14/2008	Page: 10

- Manual Selection
Use **AT+COPS** for manual selection
- Display Extended Operator Name
Use **AT+XCOPS=8** for short Operator Name
Use **AT+XCOPS=9** for long Operator Name
Use **AT+XEONS=9** for EONS long Name

2.8.3 Call Processing

- Pause dialing is not supported per compliance matrix

2.8.4 Network Selection

- Use **AT+COPS=0** to set up automatic scanning
- Use **AT+COPS=?** To display NW information
- Test for limited service:
AT+CREG=1 (in the beginning)
+CREG: 3 (=> registration denied when Reject by NW is done => limited service)
AT+XCOPS=9
+CME ERROR: operation not supported (display NW name in case of registration)

2.8.5 UICC-OTA for MSISDN update

- Use **AT+CFUN=6** at power up
- Use **AT+CNUM** to check the MSISDN

2.8.6 Enhanced Network Selection (ENS)

- Use **AT+CFUN=6** at power up
- **+STKPRO: 01,1,1,"3F007F206F31"** will be received on the Hypoterminal upon Refresh
- Use **AT+STKTR=01,0,255** to complete Refresh
- Repeat the **AT+STKTR=01,0,255** in respinse to each **+STKPRO** unsolicited message