

User Manual

of the

Siemens VDO

OPEL Immobiliser

type 5WK4 7631

System description of the Opel Immobilizer 2nd Generation Redesign

The immobilizer 2nd generation prevents drive away car theft powered by its own engine without having a valid key. It uses an inductive data transmission between transponder (mounted inside the key) and the control unit. This data link is working with a carrier frequency of 125 kHz and uses amplitude modulation for transmitting data to the transponder. For the direction from the transponder to the control unit damping modulation with pulse duration coding is used.

Functional description

After switching on the ignition the immobilizer transmits a random number to the transponder. It calculates a result and transmits it back to the immobilizer. The result is checked and if it is correct, the engine will be released. After that, the immobilizer is switched off until another start is attempted. The longest period for transmitting 125 kHz is 3 seconds.

Typical usage pattern (for Europe only)

15 operations in 24 hours with a transmission duration of 2 seconds.
→ total transmission duration of 1.25 seconds within 1 hour

Transmitter ON 1.25 seconds / hour

Transmitter OFF 3598.75 seconds / hour

Duty Cycle: $T_{ON} / T_{(ON+OFF)} \times 100\% = 1.25 / 3,600 \times 100\% = \underline{0.03\%}$

Technical Data

| | |
|---------------------|-------------------|
| Carrier frequency: | 125 kHz ± 5kHz |
| Field strength: | < 40 dBµA/m @ 10m |
| Type of modulation | ASK |
| Number of channels: | 1 |
| Power supply: | 12 V DC |
| Type of battery: | car battery |
| Transmission range: | 20 cm |

Block diagrams of the transmitter:

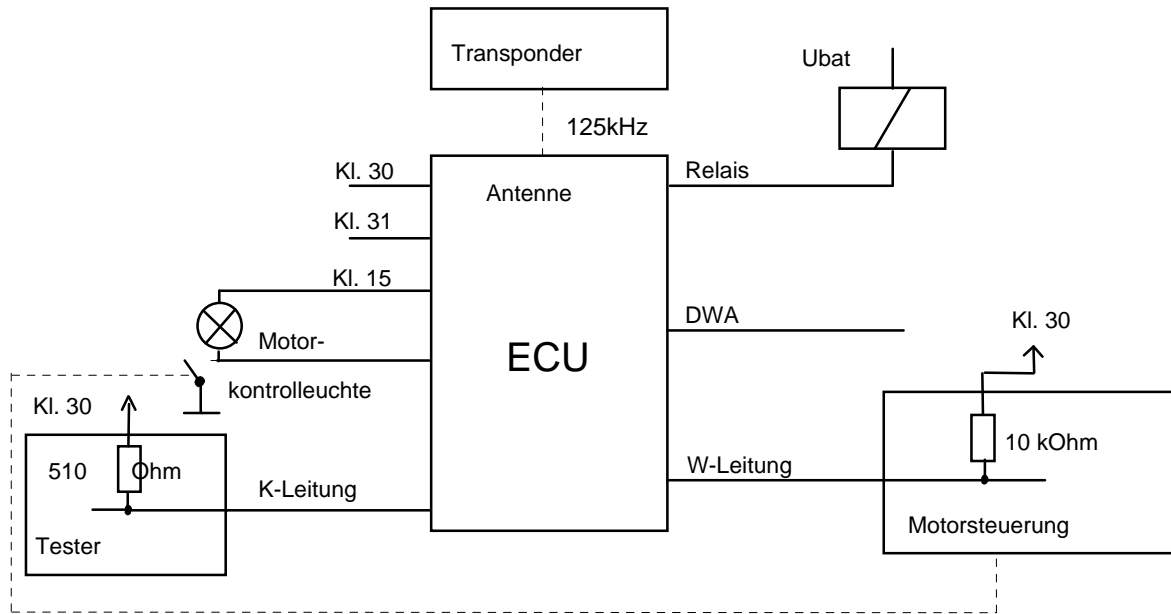

Label design

European Community:

Siemens VDO

5WK4 7631



USA/CAN:

Siemens VDO

5WK4 7631

IC: 267T-5WK47631

FCC ID:KR55WK47631

This device complies with part 15 of the FCC Rules and RSS-210.

Operation is subject to the following two conditions: (1) This device may not cause harmful interference, and (2) this device must accept interference received, including interference that may cause undesired operation.

NOTE:

Changes or modifications not expressly approved by the manufacturer could void the user's authority to operate the equipment.