

**Technical Description**  
**Functional Description**

# **User Manual**

**of the**

**Siemens VDO**

**Radio Frequency Transmitter**

**type 5WK4 8964**

## General description of the RF transmitter

The RF remote control system consists of a RF transmitter and a RF receiver mounted on a control unit. The RF transmitter is mechanically integrated in the head of the key. This transmitter is used to transmit information for locking or unlocking the vehicle by a unidirectional RF transmission line for normal remote operation by pressing a button.

In general the following functions are provided:

- Lock the car
- Unlock the car
- Unlock the boot lid of the car
- Approach light
- Panic alarm

## Power supply

The transmitter is provided with 1 lithium battery (CR 2032) that gives a power supply of +3V.

## Buttons

There are five buttons with following functions:

Action:	Usage:
Pressing the lock button	Central locking
	Activation of Alarm system
	Deactivation of Panic Alarm
Pressing the lock button for 1,5 sec.	Comfort closing
Pressing the unlock button	Central unlocking
	Deactivation of Alarm system
	Deactivation of Panic Alarm
Pressing the unlock button for 1,5 sec.	Comfort opening
Pressing the unlock button twice within 10 sec.	Two-step unlocking
Pressing the approach light button	De-/activation of Approach Light
	Deactivation of Panic Alarm
Pressing the approach light button for 1,5 sec.	
Pressing the boot lid button	Unlocking of Boot lid
	Deactivation of Panic Alarm
Pressing the panic button for 3 sec or pressing it twice within 3 sec.	Activation of Panic Alarm
	Deactivation of Panic Alarm

During activation, the button is forced to the ground via a “pull-up” within the microcontroller.

## Typical usage pattern (for Europe only)

10 lock/unlock operations in 24 hours with complete transmission duration of 1.0 seconds (100ms/operation)

4 lock/unlock operations in 24 hours with transmission duration of 40 seconds (10 seconds for 1 operation; max. value)

→ total transmission duration of 41 seconds within 24 hours

Transmitter ON      1.7                  seconds / hour

Transmitter OFF      3598.3                  seconds / hour

Duty Cycle:  $T_{ON} / T_{(ON+OFF)} \times 100\% = 1.7 / 3600 \times 100\% = 0.05\%$

## Block diagram of the transmitter

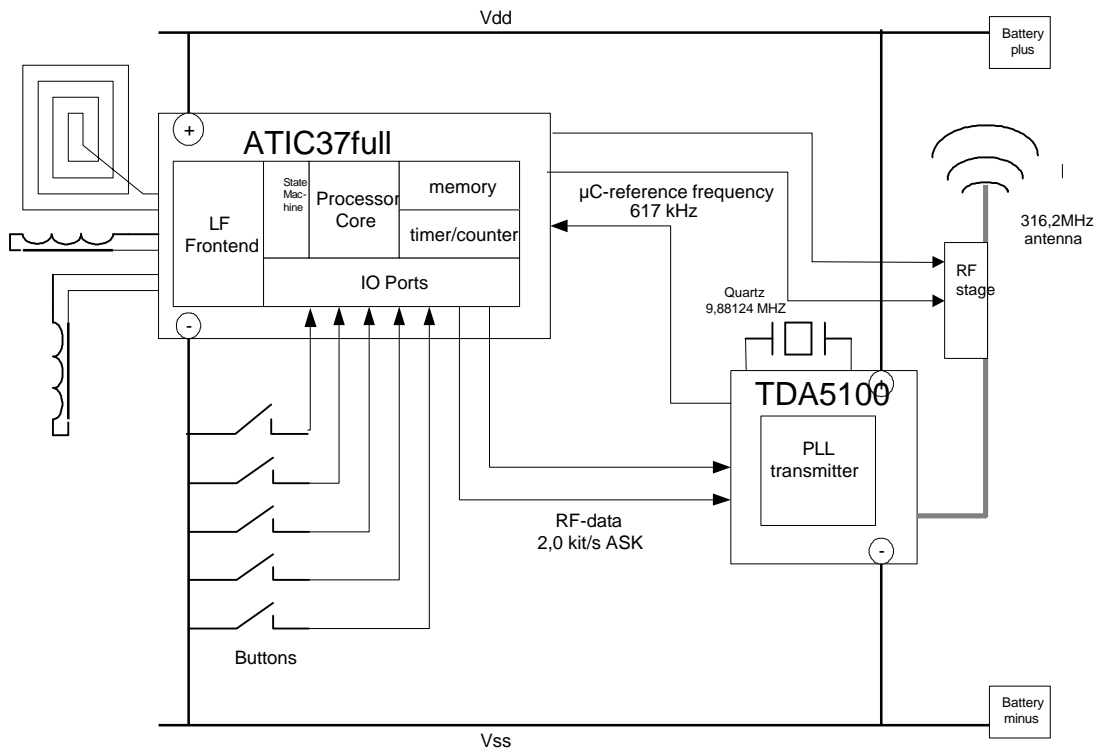

## Technical Data

Carrier frequency:	316.2 MHz $\pm$ 0.05%
Output power:	< 10 mW
Type of modulation:	ASK
Method of frequency generation:	PLL
Number of channels:	1
Power supply:	battery (CR 2032)
Type of battery:	lithium
Transmission range:	< 10 m

### NOTE:

Changes or modifications not expressly approved by the manufacturer could void the user's authority to operate the equipment.

## Label design

### USA/Canada: (316.2MHz)

Siemens VDO  
5WK48964  
FCC ID:KR55WK48964  
IC:267T-5WK48964

This device complies with part 15 of the FCC Rules and RSS-210. Operation is subject to the following two conditions: (1) This device may not cause harmful interference, and (2) this device must accept interference received, including interference that may cause undesired operation.