

# **Functional Description User Manual**

**5WK4 9137**

SIEMENS VDO Automotive

SV C BC P2 RF

IC:267T-5WK49137

FCC ID:KR55WK49137

---

# **Functional Description / User Manual**

**for**

**SIEMENS VDO**

**Comfort Access System**

**5WK4 9137**

## 1. Functional Description - Comfort Access System (CA)

### General system description

The CA-system enables convenient utilization of the vehicle. To use the vehicle, the driver only needs to take the key along with him/her. The vehicle communicates with the system inductively via antennas. These antennas are located in the rear bumper and in the interior. These antennas are driven inductively with a frequency of 125 kHz. The system's range is limited in a defined fashion by damping the body sheet metal. In the vehicle interior, the ranges of the various antennas overlap, which enables location of the key.

### Passive access control

Controlled by toggle switch on driver and passenger side.

### Passive Go (start/stop)

The system provides the function which enables starting/stopping the engine without key actuation.

The prerequisite for starting the vehicle is a key allocated to the vehicle, which is taken along by the user and is clearly inside the vehicle. By actuating the starting device, the driver starts the identification process, i.e. the PGS control unit issues a request for a valid key inside the vehicle. The key returns an appropriate response to the PGS control unit. In case of successful identification of the key, the vehicle is started and the immobilizer is deactivated.

### Main Functions

The PGS CA\_R56 control unit contains the following important functions:

- switching on FBD receiver (digital output)
- generate and amplify 125kHz sinus for inductive antennas
- control of interior and bumper antennas by switching onboard relays

**2. Block diagram of PGS CA\_R56**

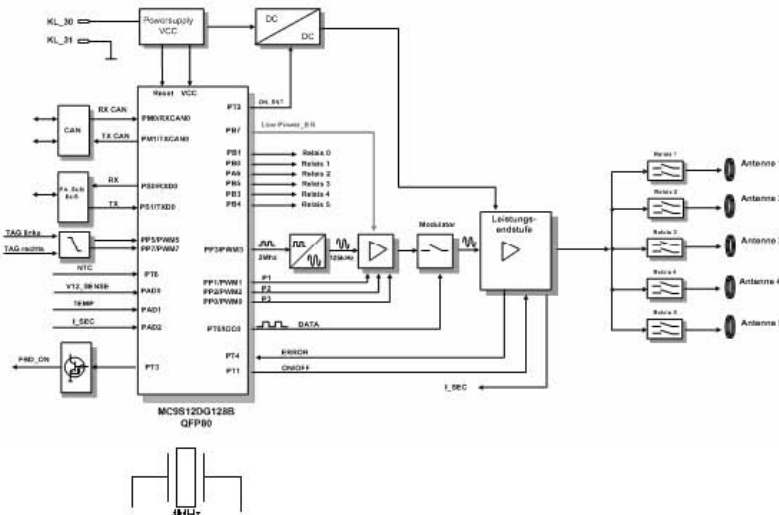

**3. Technical parameters**

PGS CA_R56 voltage range	9.0 ... 28.0V
Carrier frequency	125kHz
Band width	123,75 kHz - 126,25 kHz
Field strength	< 42 dBµA/m at 10m
Type of modulation	100% ASK
Method of frequency generation	digital sinus generator
Number of channels	1
Type of battery	Car battery
inductive Transmission range	< 2m

**4. List of variants**

<b>5WK4 9137</b>	<b>PGS CA_R56</b>
<b>5WK4 9132</b>	<b>interior antennas / trunk antenna</b>
<b>5WK4 9133</b>	<b>bumper antenna</b>
<b>5WK4 9129</b>	<b>door Antenna</b>

SIEMENS VDO Automotive

SV C BC P2 RF

IC:267T-5WK49137

FCC ID:KR55WK49137

---

### 5. Typical usage pattern

27 start / stop operations in 24 hours (10.000 operations / year) with a typical transmission duration of 39 milliseconds.

Transmitter ON      1,053      seconds / 24 hours

Transmitter OFF      86.398,95      seconds / 24 hours

Duty Cycle:  $T_{ON} / T_{(ON+OFF)} \times 100\% = 1,053 / 86.399 \times 100\% = 0,0012\%$

### 6. Label Design Europe, CANADA, US

Siemens VDO  
5WK4 9137



FCC ID:KR55WK49137  
IC:267T-5WK49137

This device complies with part 15 of the FCC Rules and RSS-210. Operation is subject to the following two conditions: (1) This device may not cause harmful interference, and (2) this device must accept interference received, including interference that may cause undesired operation.

## Homologation Board for 5WK4 9137

### Power up of test samples

The test setup consists of the following components:

- Control unit: PGS R56; 5WK4 9137
- Wiring harness: Control unit ↔ bumper antenna and power supply
- Antennas: 1 door antenna 5WK4 9129  
1 bumper Antenna 5WK4 9133
- Power Supply: 14VDC or car battery (not supplied)

The door antenna will represent the max. allowed inductive load, which the control unit can supply.

### Test configuration and operation

Connect the wiring harness to the control unit and the door antenna. More precise allocation of connector - socket is not necessary, as all connections are mechanical or color-coded. The entire test setup is connected to power via the two banana jacks on the wiring harness.

Banana jack, red = 14VDC or car battery  
Banana jack, blue = GND (ground)

The power consumption in case of operation amounts to max. 10A.

If the power supply is connected the control unit begins to operate. The connected antenna will transmit the carrier frequency with a duration of approximately **40ms** at intervals of **500ms**. The transmitter power of the control unit is adjust by 100%. With the toggle switch "bumper antenna or door antenna" you can adjust which antenna you will let send.

**This procedure does not correspond to the standard mode of operation! This procedure is only used to simplify emission measurements.**