

User Manual

of the

Siemens VDO

Remote Control System

**Type:
PL2 ID**

General description of the RF transmitter PL2 ID

The RF remote control system consists of a RF transmitter and a RF receiver mounted within the control unit. The RF transmitter is mechanically integrated in the head of the key. This transmitter is used to transmit an information for locking or unlocking the vehicle by an unidirectional RF transmission line for normal remote operation by pressing a button.

In general the following functions are provided:

- Lock the car
- Unlock the car
- Unlock the trunk of the car

Power supply

The transmitter is provided with 1 Lithium battery (CR 2032) that gives a power supply of +3V.

Buttons

There are three buttons which enable to lock and unlock the doors and to unlock the trunk.

During activation, the button is forced to the ground via a "pull-up" within the microcontroller.

Typical usage pattern (for Europe only)

10 lock/unlock operations in 24 hours with typical transmission duration of 2 seconds
→ 0,42 lock/unlock operations with one hour

Transmitter ON 0.84 seconds / hour

Transmitter OFF 3599.16 seconds / hour

Duty Cycle: $T_{ON} / T_{(ON+OFF)} \times 100\% = 0.84 / 3,600 \times 100\% = \underline{0.02\%}$

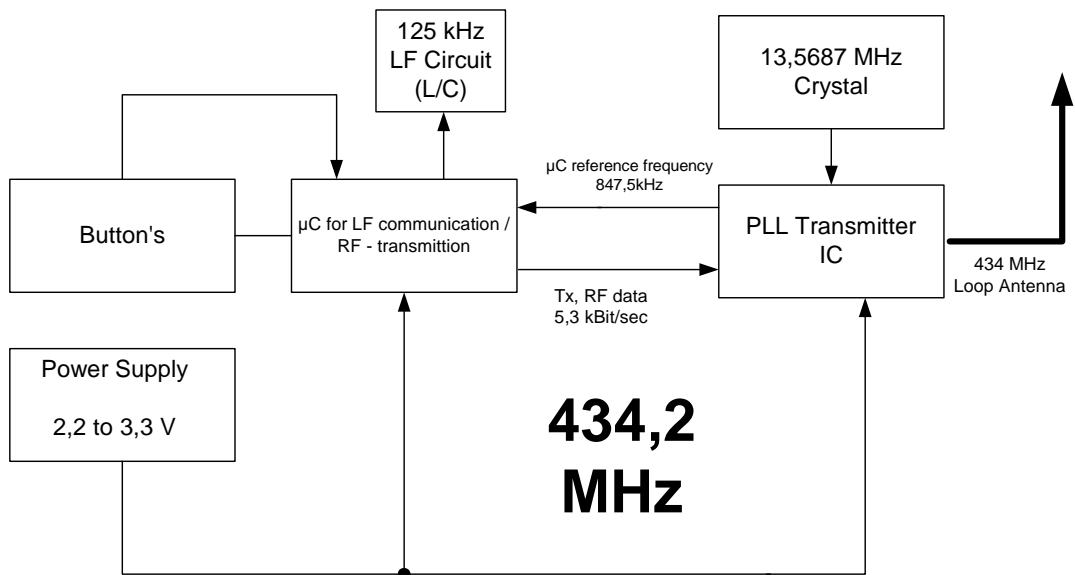
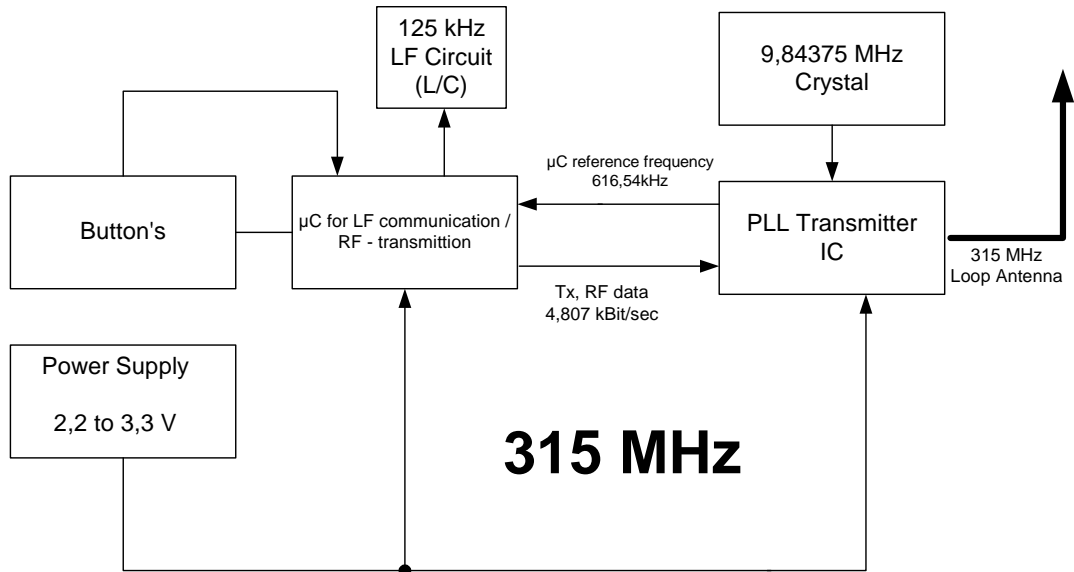
Block diagrams of the transmitter

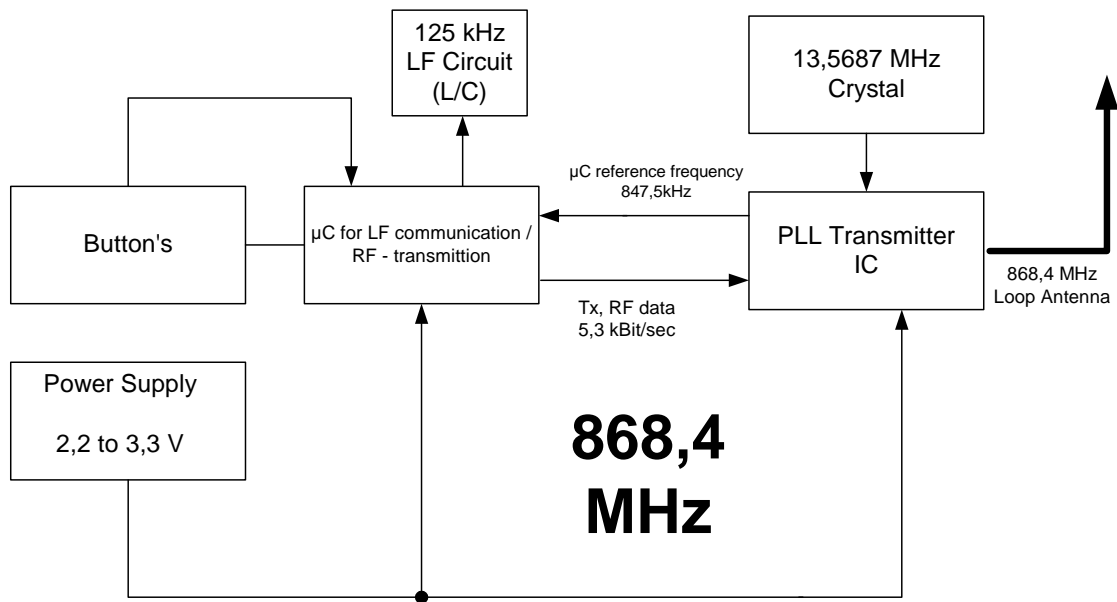

Variants

Model	Description
5WK4 9141	868.4MHz variant for Europe
5WK4 9142	434.2MHz variant for Europe
5WK4 9143	315MHz variant for USA
5WK4 9144	315MHz variant reduced power for Japan

Technical Data

Carrier frequency model 5WK4 9141:	868.4 MHz \pm 0.05%
Carrier frequency model 5WK4 9142:	434.2 MHz \pm 0.05%
Carrier frequency model 5WK4 9143:	315.0 MHz \pm 0.05%
Carrier frequency model 5WK4 9144:	315 MHz \pm 0.05%
Output power model 5KW4 9141/2/3:	< 10 mW
Field strength model 5WK49144:	< 500 μ V/m @ 3m
Type of modulation model 5KW4 9141/2/3:	FSK
Type of modulation model 5KW4 9144:	ASK
Method of frequency generation:	PLL
Number of channels:	1
Power supply:	battery (CR 2032)
Type of battery:	lithium
Transmission range:	<10 m

NOTE:

Changes or modifications not expressly approved by the manufacturer could void the user's authority to operate the equipment.

Label design

Europe: (434 MHz)

Siemens VDO

5WK4 9142



Europe: (868 MHz)

Siemens VDO

5WK4 9141



Japan: (315 MHz)

Siemens VDO

5WK4 9144

USA/CAN: (315 MHz)

Siemens VDO

5WK4 914b3

IC: 267T-5WK49143

FCC ID:KR55WK49143

This device complies with part 15 of the FCC Rules and RSS-210.

Operation is subject to the following two conditions: (1) This device may not cause harmful interference, and (2) this device must accept interference received, including interference that may cause undesired operation.