

Technical Description

Key: **5WK4 9147**

User Manual

of the

Siemens VDO

Remote Control System

Type:

5WK4 9145

5WK4 9146

5WK4 9147

5WK4 9148

General description of the RF transmitter

The RF remote control system consists of a RF transmitter and a RF receiver mounted within the control unit. The RF transmitter is mechanically integrated in the head of the key. This transmitter is used to transmit an information for locking or unlocking the vehicle by an unidirectional RF transmission line for normal remote operation by pressing a button.

In general the following functions are provided:

- Lock the car
- Unlock the car
- Unlock the trunk of the car

Power supply

The transmitter is provided with 1 Lithium battery (CR 2032) that gives a power supply of +3V.

Buttons

There are three buttons which enable to lock and unlock the doors and to unlock the trunk.

During activation, the button is forced to the ground via a “pull-up” within the microcontroller.

Typical usage pattern (for Europe only)

10 lock/unlock operations in 24 hours with typical transmission duration of 2 seconds
→ 0,42 lock/unlock operations with one hour

Transmitter ON 0.84 seconds / hour

Transmitter OFF 3599.16 seconds / hour

Duty Cycle: $T_{ON} / T_{(ON+OFF)} \times 100\% = 0.84 / 3,600 \times 100\% = \underline{0.02\%}$

Block diagrams of the transmitter

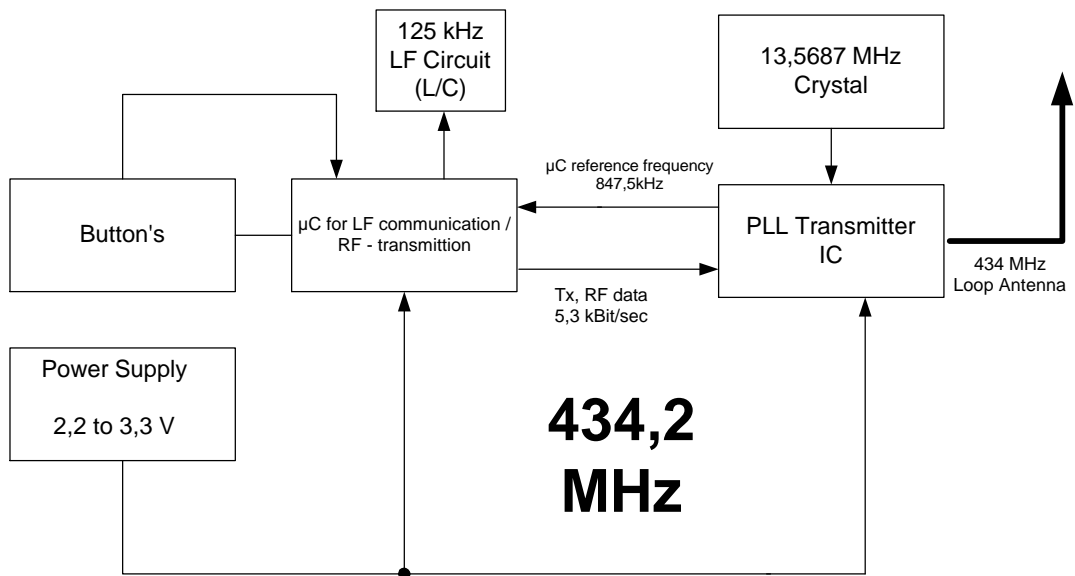
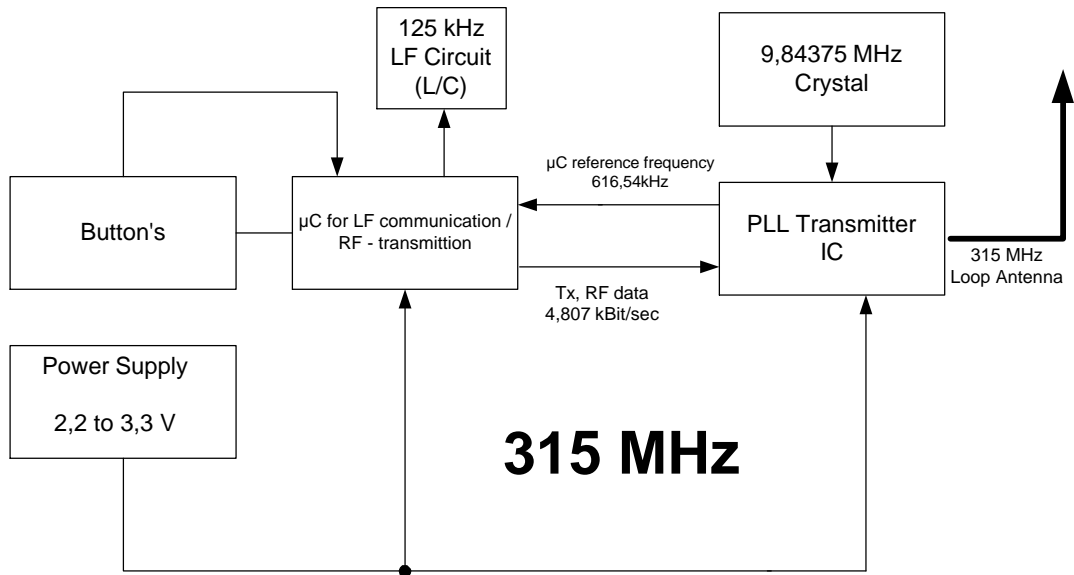

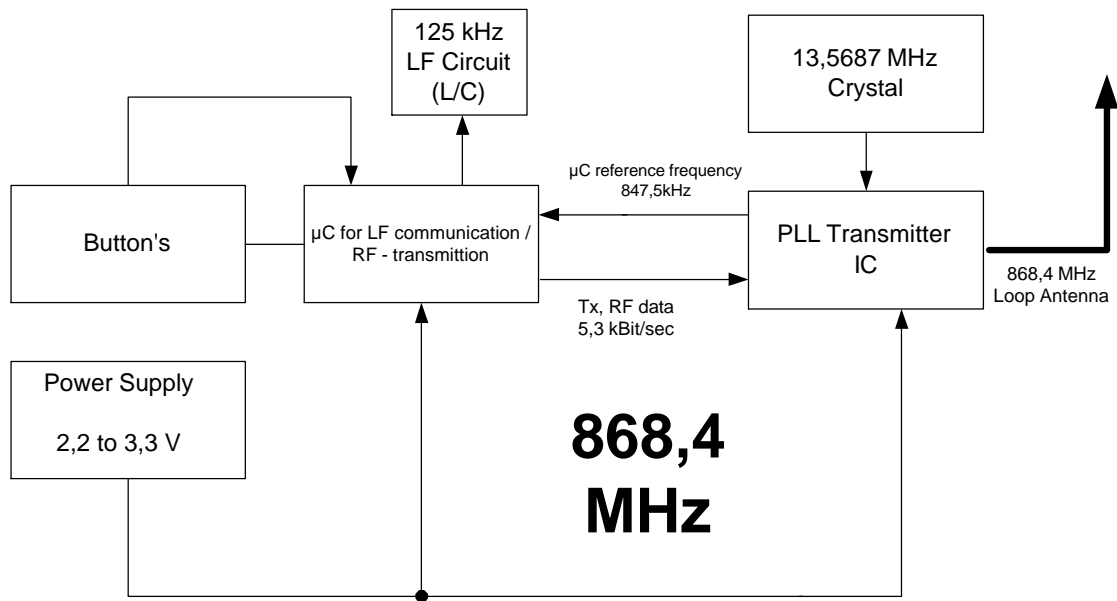

Variants

Model	Description
5WK4 9145	868.4MHz variant for Europe
5WK4 9146	434.2MHz variant for Europe
5WK4 9147	315MHz variant for USA
5WK4 9148	315MHz variant reduced power for Japan

Technical Data

Carrier frequency model 5WK4 9145:	868.4 MHz \pm 0.05%
Carrier frequency model 5WK4 9146:	434.2 MHz \pm 0.05%
Carrier frequency model 5WK4 9147:	315.0 MHz \pm 0.05%
Carrier frequency model 5WK4 9148:	315 MHz \pm 0.05%
Output power model 5KW4 9145/6/7:	< 10 mW
Field strength model 5WK49148:	< 500 μ V/m @ 3m
Type of modulation model 5KW4 9145/6/7:	FSK
Type of modulation model 5KW4 9148:	ASK
Method of frequency generation:	PLL
Number of channels:	1
Power supply:	battery (CR2032)
- Nominal voltage:	3 V
- Lowest voltage:	2, 1 V
- Highest voltage:	3, 3 V
Type of battery:	lithium
Transmission range:	<10 m
Type of RF-antenna:	Loop antenna
Length of RF-antenna:	30, 35 mm

Label design

Europe: (434 MHz)

Siemens VDO

5WK4 9146



Europe: (868 MHz)

Siemens VDO

5WK4 9145



Japan: (315 MHz)

Siemens VDO

5WK4 9148

USA/CAN: (315 MHz)

Siemens VDO

5WK49147

IC: 267T-5WK49147

FCC ID:KR55WK49147

This device complies with part 15 of the FCC Rules and RSS-210.

Operation is subject to the following two conditions: (1) This device may not cause harmful interference, and (2) this device must accept interference received, including interference that may cause undesired operation.