

Functional description / User manual

5WK50138



IC: 7812D-5WK50138
FCC ID:KR55WK50138

User Manual

of the

Continental

Radio Frequency Transmitter

Types:

Kessy 433

Kessy 315 with Panic

Kessy 315 without Panic

Basis 433

Basis 315 with Panic

Basis 315 without Panic



IC: 7812D-5WK50138
FCC ID:KR55WK50138

Content

Content	2
1. General description of the RF transmitter	3
2. Variant Overview	5
3. Power Supply.....	6
4. Typical usage pattern (For Europe Only).....	6
5. Block diagram of the transmitter	7
6. Technical Data.....	9
6.1. Kessy Tx Electrical characteristics	9
6.2. RKE Tx 433.92MHz variants:	9
6.3. RKE Tx 315 MHz variants:	9
7. Label Design.....	10
7.1. Label Design.....	10
7.2. LABEL DESIGN CANADA, MEXICO, USA (315 MHz).....	10



IC: 7812D-5WK50138
FCC ID:KR55WK50138

1. General description of the RF transmitter

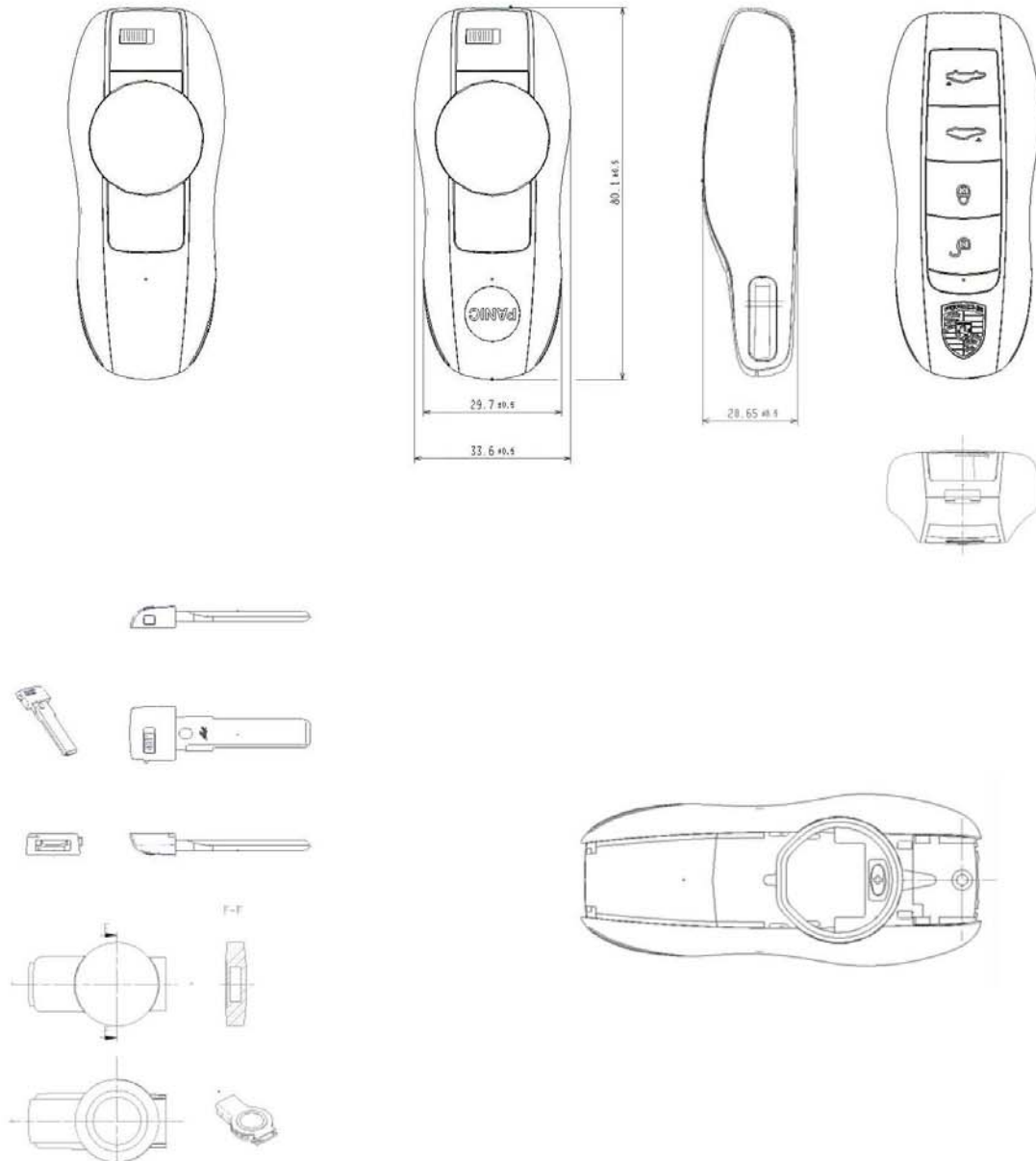



IC: 7812D-5WK50138
FCC ID:KR55WK50138

The Porsche transmitter is a handheld device to remotely control a vehicle's locking and alarm system by pressing the pushbuttons. It also provides Keyless Entry (Kessy) functions for hands-free access and start of the vehicle using the 3D-LF-frontend (without handling the transmitter that can remain in the pocket for example).

Delivered by Continental is only the transmitter part with the pushbutton electronics. The Emergency Key provides mechanical access to the vehicle. The picture shows the five-button variant of the transmitter. There are variants of the transmitter with three, four and five buttons, listed in the following table.



IC: 7812D-5WK50138
FCC ID:KR55WK50138

2. Variant Overview

Continental TNS	28-4017-3707-3-00	28-4017-3606-3-00	28-4017-3606-3-00	28-4004-0611-3-00	28-4046-0511-3-00	28-4004-0011-3-00
Type	RKE	RKE	RKE	Kessy	Kessy	Kessy
Frequency variant	433MHz	315MHz without Panic	315MHz with Panic	433MHz	315MHz without Panic	315MHz with Panic
No. of buttons	4 buttons	4 buttons	5 buttons	4 buttons	4 buttons	5 buttons
Button 1	lock	lock	lock	lock	lock	lock
Button 2	unlock	unlock	unlock	unlock	unlock	unlock
Button 3	Trunk 1	Trunk 1	Trunk 1	Trunk 1	Trunk 1	Trunk 1
Button 4	Trunk 2	Trunk 2	Trunk 2	Trunk 2	Trunk 2	Trunk 2
Button 5			Panic			Panic
PCB only	292439A4	292439A4	292439A4	292409B3	292409B3	292409B3
assembled PCB	28-4017-3806-2-00	28-4017-3405-2-00	28-4017-3405-2-00	28-4004-0809-2-00	28-4004-0209-2-00	28-4004-0209-2-00



IC: 7812D-5WK50138
FCC ID:KR55WK50138

3. Power Supply

The transmitter is provided with 1 lithium battery (CR2032) that gives a power supply of +3V.

4. Typical usage pattern (For Europe Only)

20 lock/unlock operations in 24 hours with complete transmission duration of 2.0 seconds (100ms/operation)
4 lock/unlock operations in 24 hours with transmission duration of 26 seconds (6.5 seconds for 1 operation; max. value)
→ total transmission duration of 28 seconds within 24 hours

Transmitter ON 1.2 seconds / hour

Transmitter OFF 3598.8 seconds / hour

Duty Cycle: $T_{ON} / T_{(ON+OFF)} \times 100\% = 1.2 / 3600 \times 100\% = \underline{0.033\%}$



IC: 7812D-5WK50138
FCC ID:KR55WK50138

5. Block diagram of the transmitter

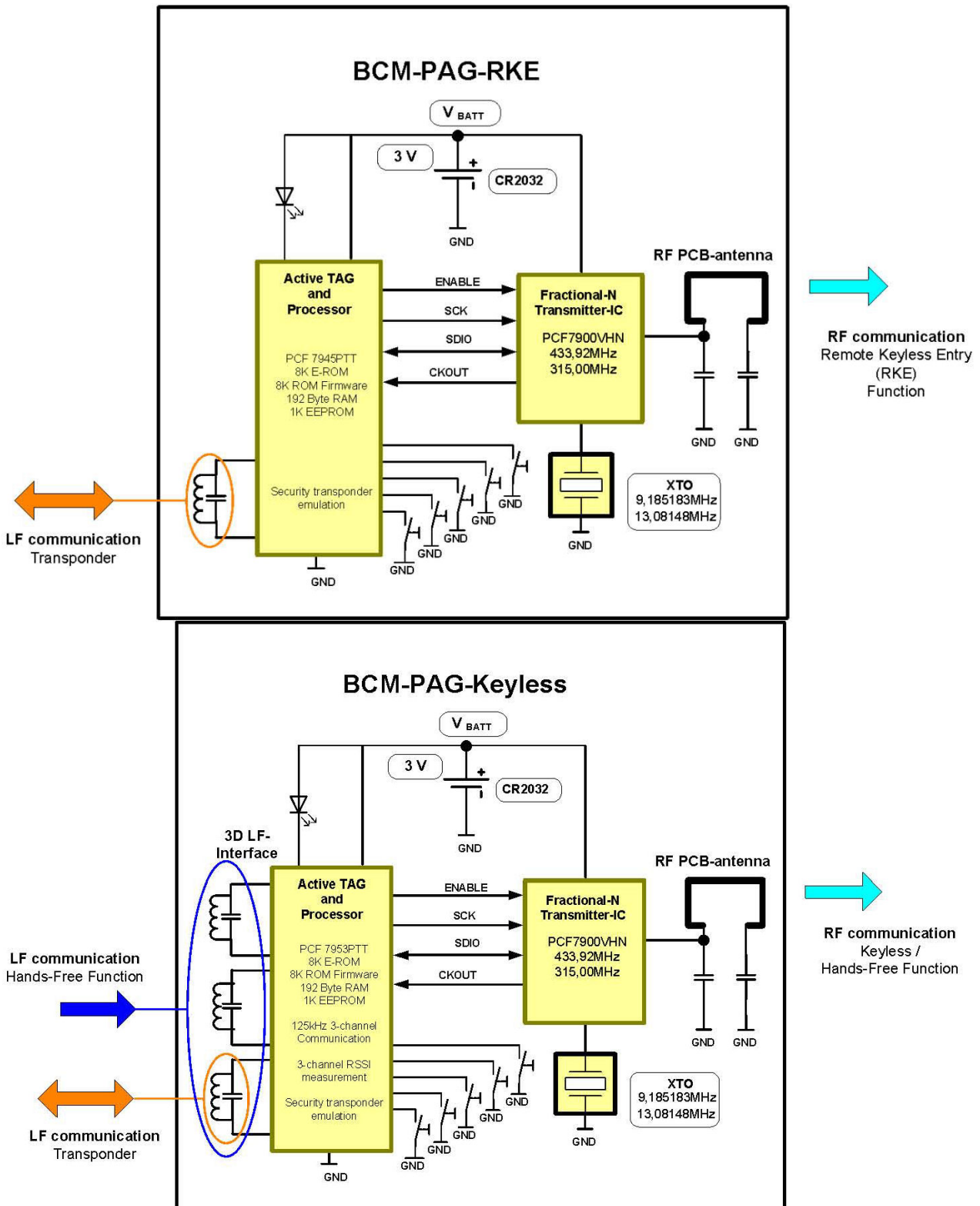



IC: 7812D-5WK50138
FCC ID:KR55WK50138

The electronics consist of the following functional groups:

- a) Battery CR2032
- b) Micro controller with 3D LF front-end
- c) LF detector coils
- d) Pushbuttons
- e) RF-Oscillator
- f) LED



IC: 7812D-5WK50138
FCC ID:KR55WK50138

6. Technical Data

6.1. Kessy Tx Electrical characteristics

Parameter	Unit	Min.	Typ.	Max.
Supply voltage	V	2.4	3	3.6
Quiescence current	µA		4.5	6
Battery lifetime (10 actuations per day) [/years]	a		2	
KESSY LF input Carrier Frequency	kHz		125	
KESSY LF input Modulation method		ASK		

6.2. RKE Tx 433.92MHz variants:

Parameter (@+22.5°C)	Unit	Min.	Typ.	Max.
Center frequency	MHz	433.820	433.920	434.020
Frequency shift	kHz	± 20	± 35	± 50
RF-Power (EIRP typ.)	mW			< 10

6.3. RKE Tx 315 MHz variants:

Parameter (@+22.5°C)	Unit	Min.	Typ.	Max.
Carrier frequency	MHz	314.900	315.000	315.100
Frequency shift	kHz	± 20	± 35	± 50
RF-Power (EIRP typ.)	dBµV/ m			< 79.2

NOTE:

Changes or modifications not expressly approved by the manufacturer could void the user's authority to operate the equipment.



IC: 7812D-5WK50138
FCC ID:KR55WK50138

7. Label Design

7.1. Label Design

Continental
5WK50137



7.2. LABEL DESIGN CANADA, MEXICO, USA (315 MHz)

Continental
5WK50138

IC: 7812D-5WK50138
FCC ID:KR55WK50138

Entry Owners Manual, Canada, USA:

NOTE

This device complies with part 15 of the FCC Rules and RSS-210. Operation is subject to the following two conditions: (1) This device may not cause harmful interference, and (2) this device must accept interference received, including interference that may cause undesired operation.

CAUTION

Changes or modifications not expressly approved by the manufacturer could avoid the user's authority to operate the equipment.