

Functional description User Manual

5WY7975



FORD PATS Clip-On

Homologation Support Documents

SV C BC P2 RF_LF
RF Engineer

Aris Lambropoulos
Tel: (248) 764-6771
aris.lambropoulos@siemens.com

2. Module Housing

The module assembly contains a bobbin assembly, a printed circuit board assembly, and a top cover. The bobbin assembly and top cover are a glass filled nylon material, PBT-GF20. A four-pin connector and antenna ring are injection molded into the bobbin assembly. The PCB is 1 Oz. Copper, double sided, all SMD components will be affixed to the PCB by a double -sided IR reflow process. The PCB will mount to the housing via six press fit pins. The wire antenna is connected to the PCB by two of the six press fit pins. The top cover attaches to the bobbin assembly with four snaps and helps protect the wire antenna and PCB.

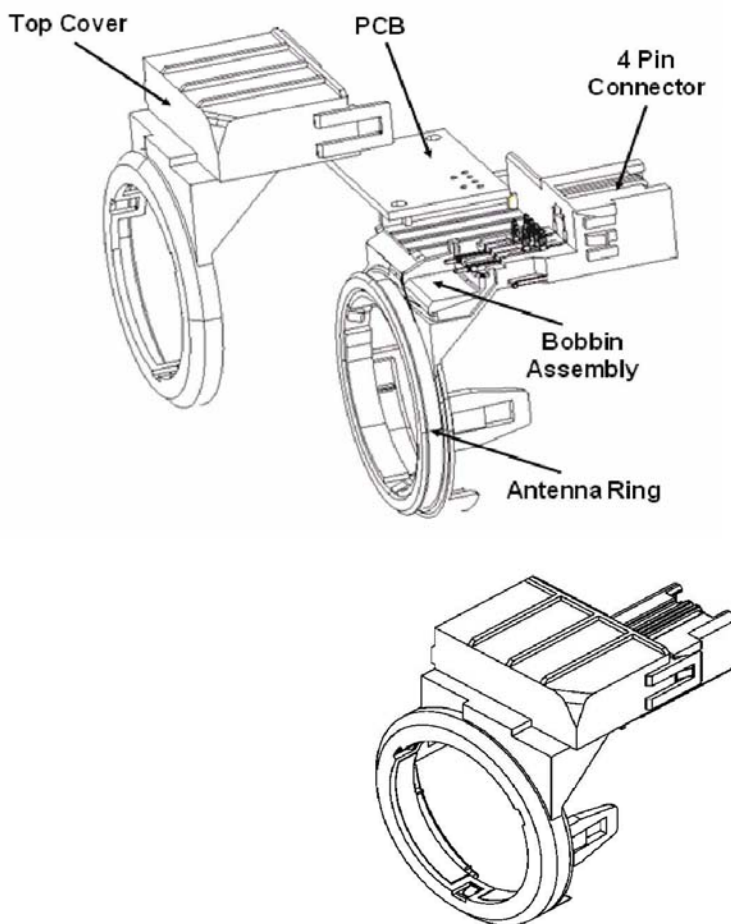

4. Interface Requirements

4.1 PATS Clip_On Connector

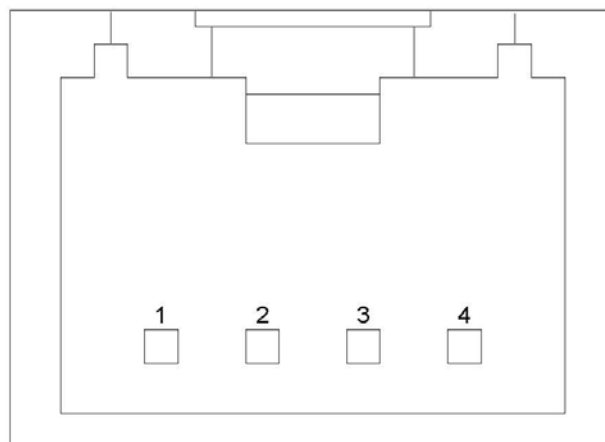

Mechanical Connector

Front View Looking Into Connector

Pin #	Pin Description	Steady State Current (Key Off)	Steady State Current (Key Run/Start)	Operating Voltage	Frequency or /MIN BIT Width	% Duty
1	Ignition	0 mA	50 mA	VBatt	DC	DC
2	Ground	0.015 mA	50 mA	0v	DC	DC
3	TX	0 mA	12 mA for 50 ms	0 – VBatt	64 μ s	VAR.
4	RX (SCI-out)	0 mA	12 mA < 1 sec.	0 – VBatt	15.625kbaud	VAR.



Table 1 Pin Description

4.2 Terminal Definitions and Characteristics

All inputs and outputs shall be capable to withstand any single point failure of a short to battery or ground, through any resistive path, without physical damage to the component while the fault is occurring, and any physical damage and/or functional degradation once the fault is removed.

4.2.1 PATS Clip_On Permanent Battery and Ground Connections

Signal Name	Signal Function	Electrical Characteristics
Ignition	Power to the module	Min Operating Voltage: 7 V Max Operating Voltage: 24 V I _{nom} @12.0 V: 32mA
Ground	Ground to the module	I _{nom} @ 12.0 V: 32mA

Table 2 Battery and Ground Connection Ratings

4.2.2 PATS Clip_On Input

All digital inputs shall meet the applicable Generic Body Module SDS requirements unless otherwise agreed to by Ford Motor Company

Signal ID	Functional Name	Active (On) State	Inactive (Off) State	Min Logical High Threshold	Max. Logical Low Threshold
Tx Input	Transmit Data	Low	High (1KOhm pull up resistor)	3.97 V	3.04V

Table 3 Tx Input

¹ The given limits include a maximum GND voltage shift between SJB Logic GND and switch GND of ± 1 V.

4.2.3 PATS Clip_On Output

Signal ID	Type of Output/Driver	Minimum functional voltage	Maximum functional voltage	Minimum performance voltage	Maximum performance voltage	Output short circuit protection
Rx Output	Low Side	7V	24V	7V	24V	Provided

SV C BC P2 RF_LF
RF Engineer

Aris Lambropoulos
Tel: (248) 764-6771
aris.lambropoulos@siemens.com



	Driver					
--	--------	--	--	--	--	--

Table 4 Rx Output

Characteristics:

- Short circuit to ground and overload protections are provided
- Maximum Low output voltage: 0.58V
- Operating Current at Nominal Voltage (12.0V)= 12mA
- Nominal Frequency= 15.625KHz
- Minimum/Maximum Frequency= 14.843KHz/16.407KHz

4.2.4 Serial Communication

The transceiver is to communicate transponder data to the Control function using a 15.625 kHz +/- 5% serial communications interface signal. The signal is to be in standard UART format with one start bit and one stop bit, and no parity. The signal exiting the transceiver module shall be asserted low (ground).

The serial communication will exactly mirror the transponder receive signal, except for the addition of diagnostic bytes and start and stop bits. This means that a transponder "1" signal, as specified by the appropriate transponder ES, will correspond to a UART "1" signal.

5. Label

Siemens VDO
5WY7975
FCC ID:KR55WY7975
IC:267T-5WY7975

Note Owner Manual:

This device complies with Part 15 of the FCC Rules. Operation is subject to the following two conditions:

- (1) This device may not cause harmful interference, and
- (2) this device must accept any interference received, including interference that may cause undesired operation.

This device complies with RSS-210 Rules "Operation is subject to the following two conditions: (1) this device may not cause interference, and (2) this device must accept any interference, including interference that may cause undesired operation of the device."

Caution:

Any changes or modifications not expressly approved by the party responsible for compliance could void the user's authority to operate this equipment.

SV C BC P2 RF_LF
RF Engineer

Aris Lambropoulos
Tel: (248) 764-6771
aris.lambropoulos@siemens.com

Using the FORD CRYPTOGRAPHIC TRANSCEIVER TEST BOX and NUTI Software

Before starting the program please connect the following items shown below.



RS232 connection from computer com port

Module harness

Test box power

Transmit control line: NORMAL is for normal communication and ON turns the antenna output continuously.

Test box power switch



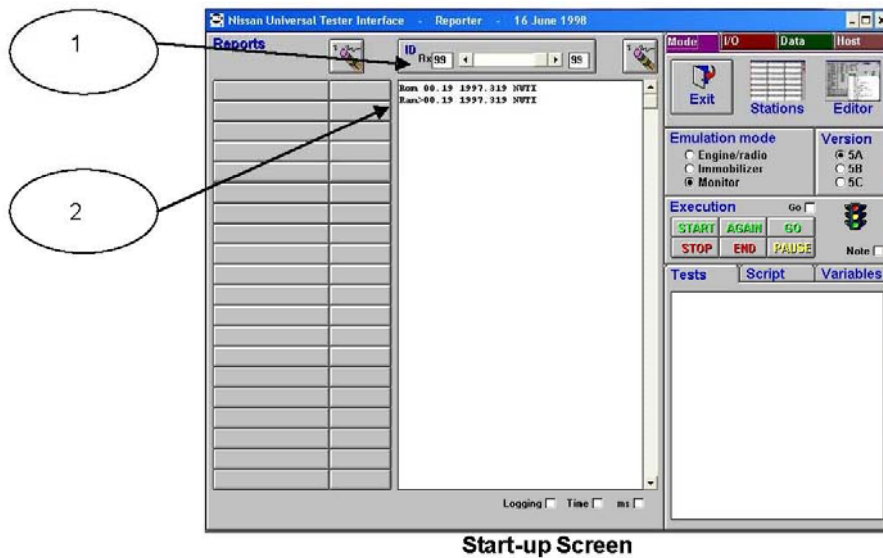

1. Click the "Nissan" Icon on the computer desktop.
2. The above Start-up screen should appear and a "99" (1) should in the ID RX box.
3. In the main screen a ROM and RAM message (2) should appear.

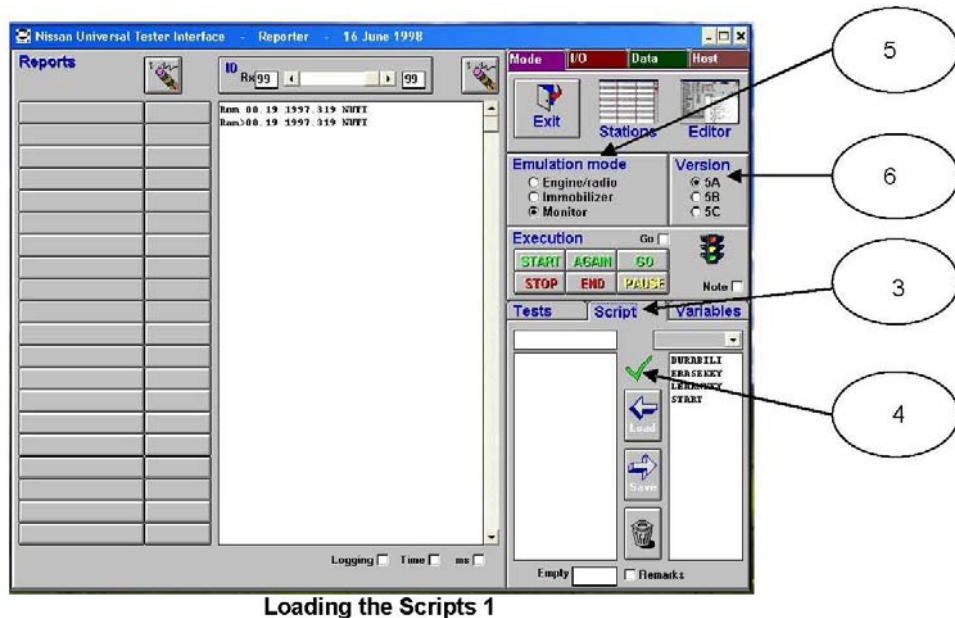

4. Press the Script Tab (3) to display the Script to be used. They should be located in Emulation mode (5) "Monitor" Version (6) "5A". To check if the scripts are already loaded click Check Mark (4).

- If the scripts are in E² they will appear in the box (7). If the scripts do not appear in the window they will have to be loaded. To do that select all the scripts by selecting the first one and drag the cursor down to select them all (8). Press load button(9) and the scripts will appear in the box (7).

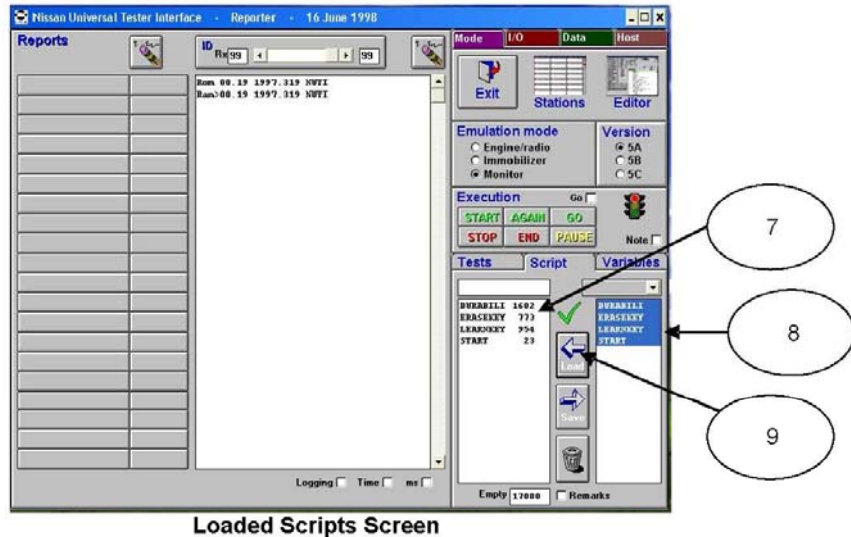

- To Run the Script select "Start script" (10) and it should load in the box (11). To run the script press the **START** Button (12).

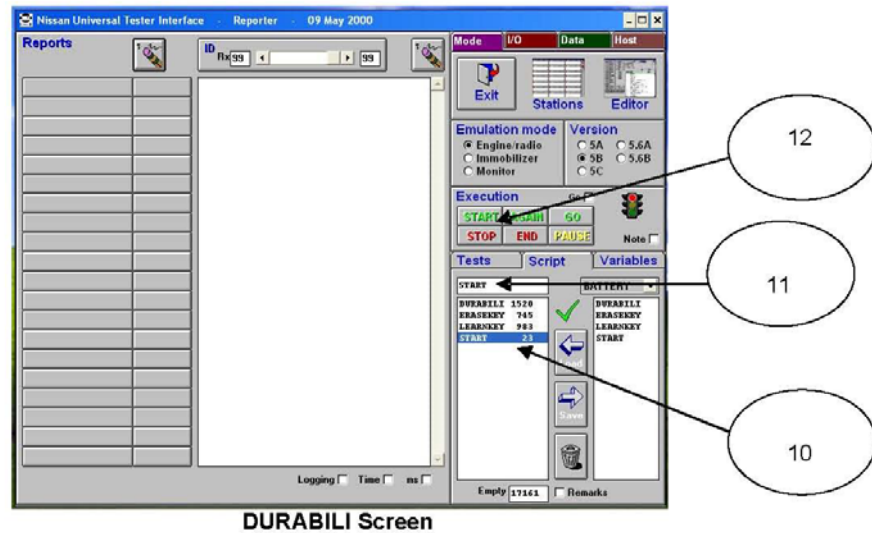

7. On the left of the screen a list of possible error codes will be displayed. The IGN CYC is the count of how many ignition cycles have occurred (13) and TPOK is how many successful communications have occurred between the module and the transponder. If there are any problems one of the error messages will turn red and record a failure. The module will keep cycling until the stop button (14) is pressed.

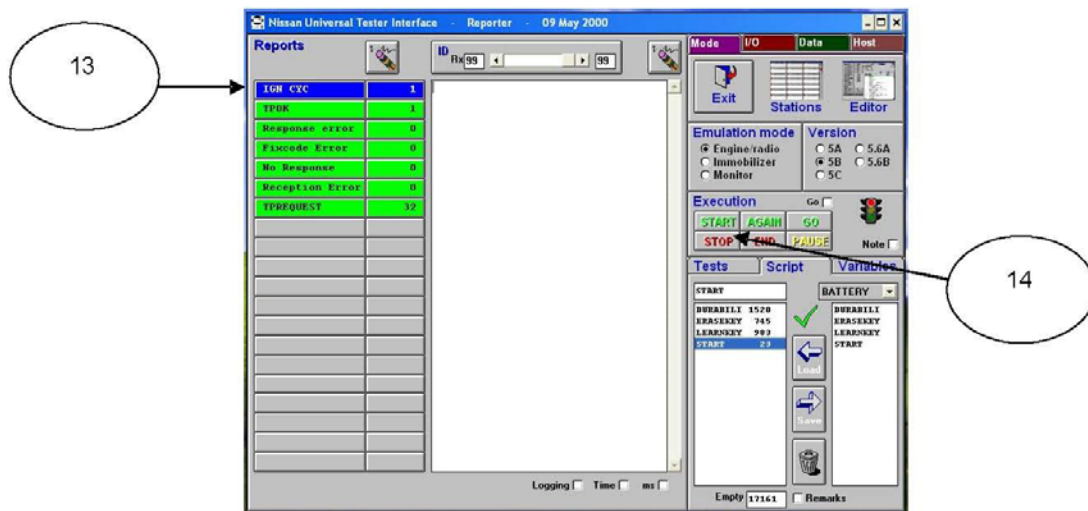

8. To set the module into constant transmit mode click the 5AB tab (15) and make sure that BAT and IGN are both lighted(16). If they are not lighted click on the boxes (17) to turn them on. **Note: Make sure that the module is not cycling when trying to setup this test.** Now turn the Transmit control line from NORMAL to ON to turn the antenna output continuously.

