

Purpose: **Door Handle Sensor - Audi D5 NFC**

Scope:

Product name	Variant	Continental Part number	Audi Part number
DHS Audi D5 NFC - L	NFC Left	A2C 114 793	4N1.927.753
DHS Audi D5 NFC - R	NFC Right	A2C 114 797	4N1.927.754

**Door Handle Sensor Audi D5 NFC**  
-  
**product overview – usage for homologation**

Version AA

Designed by		Date	Department	
Released by		Designation		
	IMS ID	SAP ID	Document version as of	Pages
	161711	10 348616	April 27, 2017	1 of 33

## Version History

Item TBD (To be defined) or TBC (To be Confirmed) in blue color.

Item Updates compared to previous revision in yellow color

Document version	Change description (including ECM number)	Date/ Status
AA	First Version	26/04/2017

Designed by	Date	Department		
Released by				
	Designation			
	IMS ID 161711	SAP ID 10 348616	Document version as of April 27, 2017	Pages 2 of 33

Table of Contents:

1 General..... 5

    1.1 Contact ..... 5

    1.2 Glossary ..... 5

    1.3 Validity and Track Changes ..... 6

    1.4 Type of Sensor ..... 6

    1.5 Sensor Functions ..... 6

    1.6 NFC Reader Principle..... 7

    1.7 Example of sensor use..... 7

2 System Architecture..... 8

    2.1 Alternative System Architectures ..... 8

    2.2 Dynamic Behaviors..... 8

    2.3 System Architecture ..... 9

    2.4 Components ..... 10

    2.5 Materials ..... 11

        2.5.1.1 Storage Temperature Range..... 11

        2.5.1.2 Operating Temperature Range..... 11

    2.5.2 Assembly / Sealing..... 11

        2.5.2.1 Module Sealing ..... 11

    2.6 Connector requirements..... 11

        2.6.1 Connector Reference..... 11

        2.6.2 Connector Pinout..... 12

    2.7 Variants ..... 13

        2.7.1 Right/Left Variants..... 13

    2.8 Electronics Structure and Interface ..... 14

        2.8.1 Electronics Block Diagram ..... 14

        2.8.2 Operating Temperature Range..... 14

        2.8.3 Operating Voltage Range..... 14

        2.8.4 Peak Power Consumption ..... 14

        2.8.5 Sleep Power Consumption ..... 16

        2.8.6 Current Consumption ..... 16

        2.8.7 CAN Voltage Range..... 16

3 Misuse Protections ..... 17

4 Communication..... 18

    4.1 CAN Communication Protocol ..... 18

        4.1.1 Lock Detection Message..... 18

        4.1.2 Unlock Detection Messages ..... 18

        4.1.3 DHS Error Message..... 19

    4.3 NFC Communication..... 20

        4.3.1 NFC type ..... 20

Designed by	Date	Department		
Released by				
	Designation			
	IMS ID 161711	SAP ID 10 348616	Document version as of April 27, 2017	Pages 3 of 33

- 4.3.2 Actuator test..... 20
- 5 Detection area ..... 22
  - 5.1.1 Unlock Detection Area..... 22
  - 5.1.2 Lock Detection Area ..... 22
  - 5.1.3 NFC Detection Area ..... 22
- 6 Homologation setup ..... 24
  - 6.1 General Test conditions ..... 24
  - 6.2 Material provided by Continental ..... 24
  - 6.3 DHS detection tracking..... 24
    - 6.3.1 DHS connection instructions: ..... 25
    - 6.3.2 Test box signals description: ..... 28
    - 6.3.3 Test box function: ..... 32

Designed by		Date	Department
Released by			
	Designation		
	IMS ID 161711	SAP ID 10 348616	Document version as of April 27, 2017
			Pages 4 of 33

# 1 General

## 1.1 Contact

Function	Name	Email	Phone
Project Leader	Andreas Moser	Andreas.moser@continental-corporation.com	+33 5 61 19 80 81
System Engineer	Stéphan Baudru	Stephan.baudru@continental-corporation.com	+33 5 61 19 74 02
Electronic Engineer	Cyril Robin	Cyril.robin @continental-corporation.com	+33 5 61 19 53 41
Software Engineer	Simon Forster	Simon.forster@continental-corporation.com	+33 5 61 19 33 87
Mechanical Engineer	Paul Raison	paul.raisson@continental-corporation.com	+33 5 61 19 55 31
Quality Engineer	Cindy Bardalou	Cindy.bardalou@continental-corporation.com	+33 5 62 23 15 05

## 1.2 Glossary

- D5/C8:** Audi platforms names
- DH:** Door Handle (means Outside Door Handle)
- DHS:** Door Handle Sensor Module (Unlock and Lock capacitive sensors)
- LF:** Low Frequency (125kHz signal for communication from ECU to Keyfob)
- RF:** Radio-Frequency (433 MHz signal for communication from Keyfob to ECU)
- ECU:** Electronic Control Unit
- BCM:** Body Controller Module
- BCM2:** Audi ECU name
  
- NFC :** Near Field Communication
- PCD :** Proximity Coupling Device (the Reader)
- PICC :** Proximity Integrated Circuit Card (the Smartcard/the Smartphone)
  
- SE:** System Engineering
- ME:** Mechanical Engineering
- EE:** Electrical Engineering
  
- HW:** Hardware
- SW:** Software
- HSI:** Hardware Software Interface
- ICT:** In Circuit Tester

Designed by	Date	Department	
Released by			
	Designation		
	IMS ID 161711	SAP ID 10 348616	Document version as of April 27, 2017
		Pages 5 of 33	

**EOL:** End of Line (Tester)  
**RT:** Room Temperature  
**DV:** Design Validation  
**PV:** Product Validation  
**EMC:** Electro Magnetic Compatibility

**FMTT:** Flash Monitoring and Tuning Tool (Continental Development Tool)  
**FMDD:** Continental Development Tool replacing the FMTT  
**DGL:** Design GuideLines

### 1.3 Validity and Track Changes

Items or parameters values changed compared to previous revision are highlighted in yellow.  
 Items or parameters values to be defined or to be confirmed are highlighted in blue.

### 1.4 Type of Sensor

This sensor is a DHS.

The DHS is a standalone module with capacitive and NFC unctions.

This module is integrated into a DH, and used in Keyless Entry System, enabling 'key-free' Vehicle Unlocking and Locking.



### 1.5 Sensor Functions

The DHS has 3 main functions :

- Unlock Function : Capacitive detection with 2 detection ranges.
- Lock Function : Capacitive detection with 2 detections ranges.
- NFC Function : Read/Write function of NFC Smartcards/Smartphones.

Designed by	Date	Department		
Released by				
	Designation			
	IMS ID 161711	SAP ID 10 348616	Document version as of April 27, 2017	Pages 6 of 33

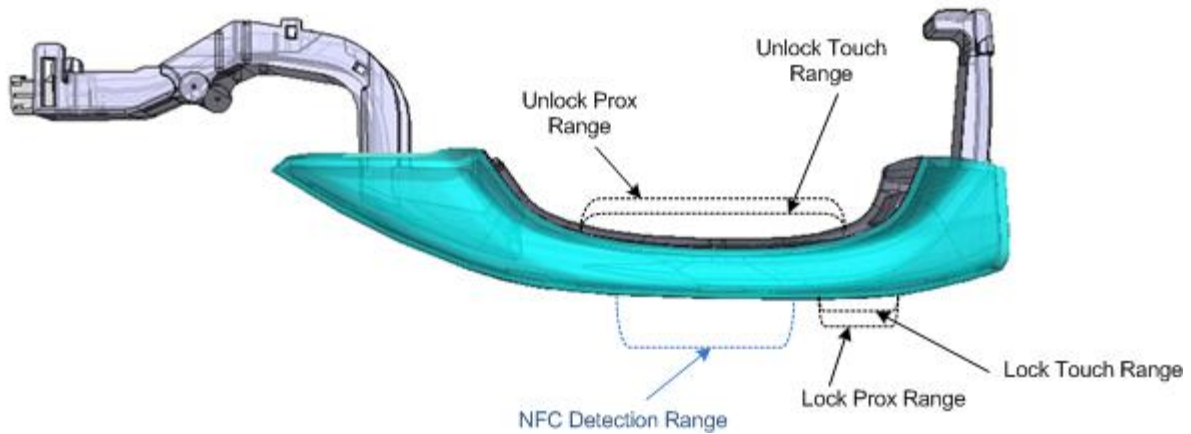

### 1.6 NFC Reader Principle

The NFC principle is based on electromagnetic coupling between 2 devices at close distance (few cm).

The PCD emits a electromagnetic field on a 13.56 Mhz carrier. It will power the PICC via Induction.

The PCD can transmit data via Miller Coding and receive data back via Load modulation.

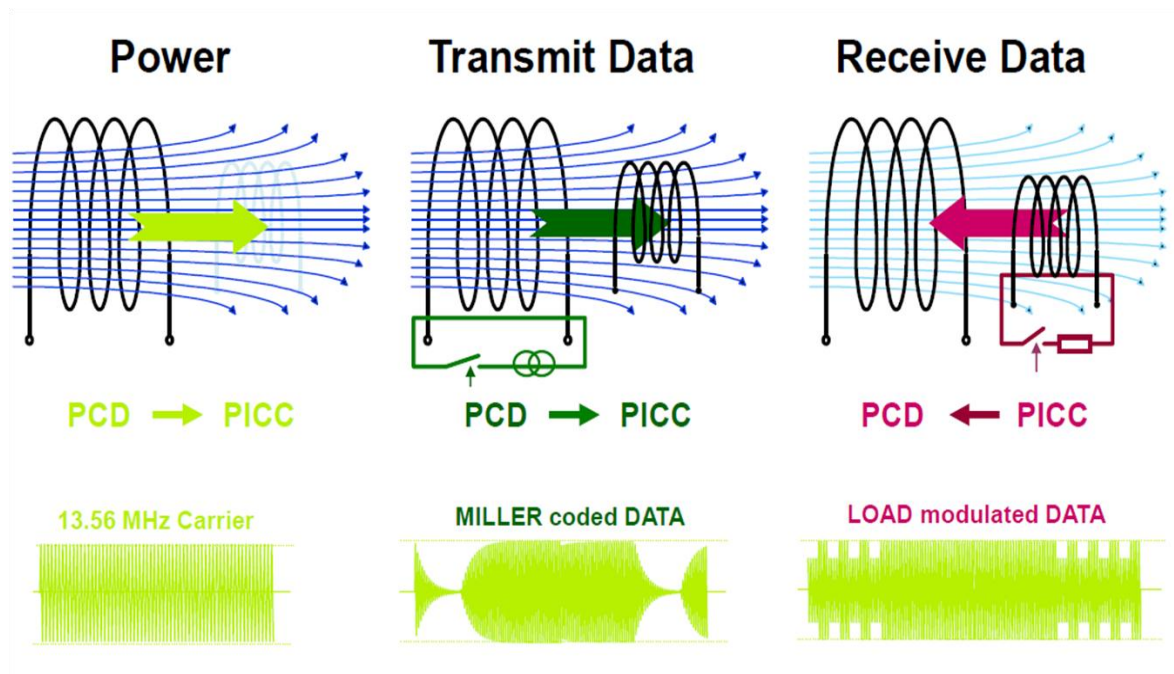

### 1.7 Example of sensor use

Example of Vehicle Access Process (Unlocking):

Designed by	Date	Department		
Released by				
	Designation			
	IMS ID 161711	SAP ID 10 348616	Document version as of April 27, 2017	Pages 7 of 33

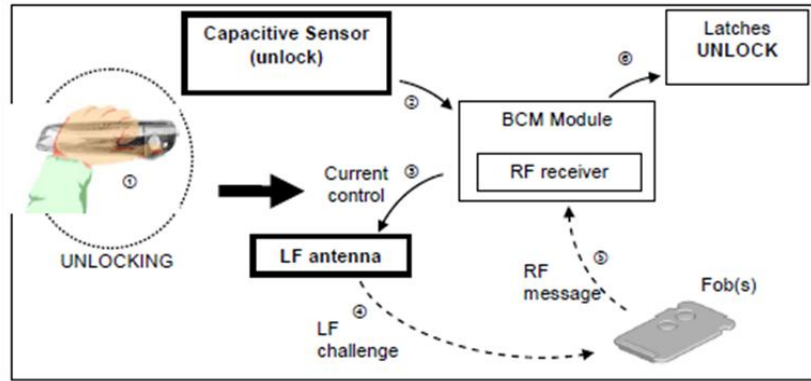

As the user's hand approaches the capacitive sensor UNLOCK detection area, sensor communicates detection to BCM Module. Then, the corresponding LF antenna on front side is driven by system to send LF challenge to fob(s) to perform the user's identification process.

The same principle is used to Lock the vehicle, with a capacitive sensor LOCK detection area. The NFC device tap is used to toggle the vehicle locking status.

## 2 System Architecture

### 2.1 Alternative System Architectures

Major evaluation criteria for architecture solutions was robustness, proven in use and cost. Therefore the generic system architecture for Capa/NFC sensors proven in use in the generic project was chosen.

### 2.2 Dynamic Behaviors

Dynamic behaviors, i.e. how the systems elements interact with each other dynamically, are mainly driven by the SW.

Then, the timings and sequence charts are described in EE/SW Interface (HSI, IMS 161922) and SW Requirements (IMS 161715)

Designed by		Date	Department	
Released by				
	Designation			
	IMS ID 161711	SAP ID 10 348616	Document version as of April 27, 2017	Pages 8 of 33



## 2.3 System Architecture

### DHS AuD5 NFC System Architecture

Remarks :  
 - Blue elements are part of the EE architecture and showed only for illustration  
 - the corresponding interfaces are in the scope of EE development.

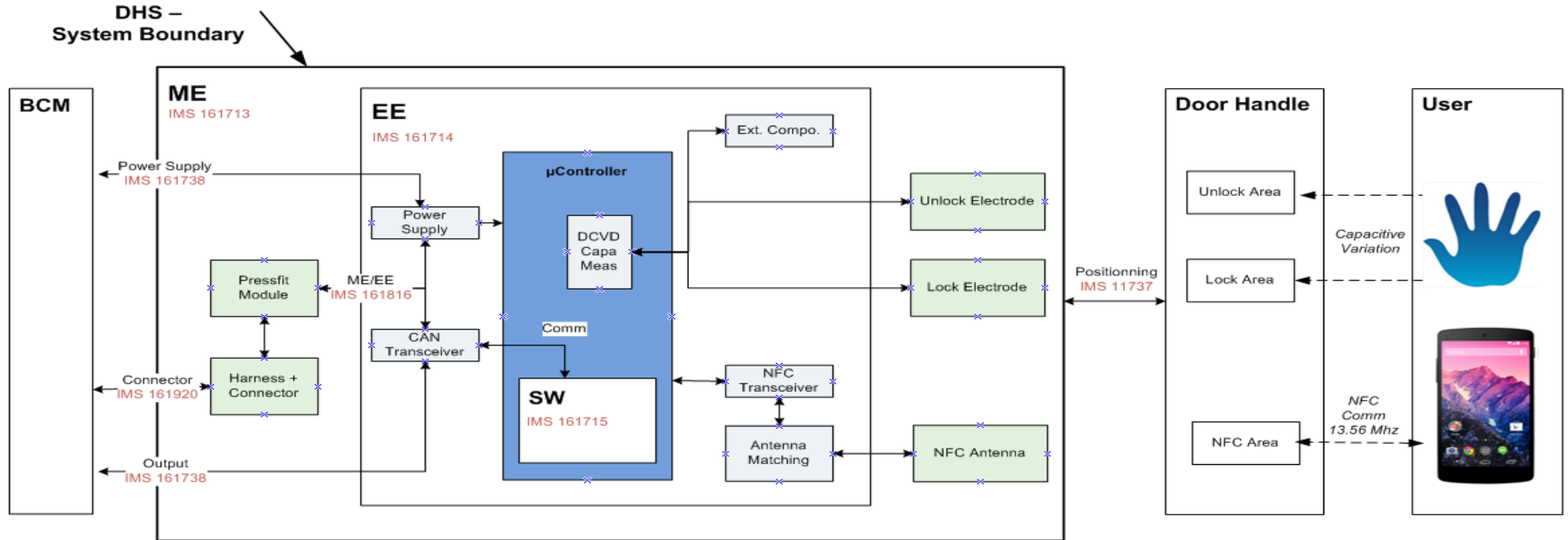

Designed by	Date	Department		
Released by				
	Designation			
	IMS ID 161711	SAP ID 10 348616	Document version as of April 27, 2017	Pages 9 of 33

Transmittal, reproduction, dissemination and/or editing of this document as well as utilization of its contents and communication thereof to others without express authorization are prohibited. Offenders will be held liable for payment of damages. All rights created by patent grant or registration of a utility model or design patent are reserved.

## 2.4 Components

ID: 161948	State: Released
------------	-----------------

The DHS module shall be composed of:

- a packaging:
  - plastic housing
  - plastic cover
  - potting material
  - foam pad on Lock Area (the function is to keep the water out of the zone)
- a connection module:
  - pressfit module
  - harness + splices
  - connector
- an electronic detection module:
  - PCB with electronic circuit (for detection technology)
  - Unlock Electrode (sensitive element) metal-stamping soldered on the PCB
  - Lock Electrode (sensitive element) and NFC antenna on Flex-PCB soldered on the PCB

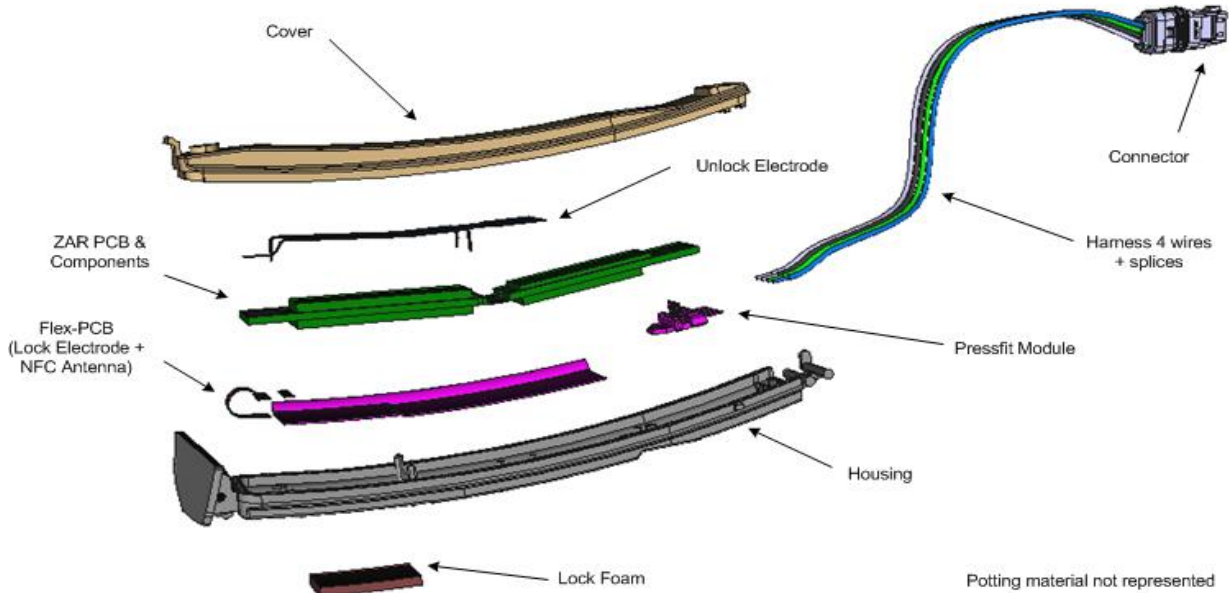

Designed by	Date	Department	
Released by			
	Designation		
	IMS ID 161711	SAP ID 10 348616	Document version as of April 27, 2017
		Pages 10 of 33	

## 2.5 Materials

### 2.5.1.1 Storage Temperature Range

ID: 161950	State: Released
------------	-----------------

The Mechanical Design shall guarantee the sensor robustness over Temperature storage range: -40°C to +90°C.

### 2.5.1.2 Operating Temperature Range

ID: 161951	State: Released
------------	-----------------

The Mechanical Design shall guarantee the sensor robustness over Temperature operating range: -40°C to +70°C.

## 2.5.2 Assembly / Sealing

### 2.5.2.1 Module Sealing

ID: 161954	State: Released
------------	-----------------

The DHS shall be sealed with PolyUrethane (PU) resin.  
The sealing process shall ensure absolute water tightness.

## 2.6 Connector requirements

### 2.6.1 Connector Reference

ID: 161919	State: Released
------------	-----------------

The connector is a directed part from Audi.

**Connector Designation:** Tyco MCON 4 ways, Coding B color white

**Audi Reference:** 4N0.973.704.A

Designed by	Date	Department		
Released by				
	Designation			
	IMS ID 161711	SAP ID 10 348616	Document version as of April 27, 2017	Pages 11 of 33

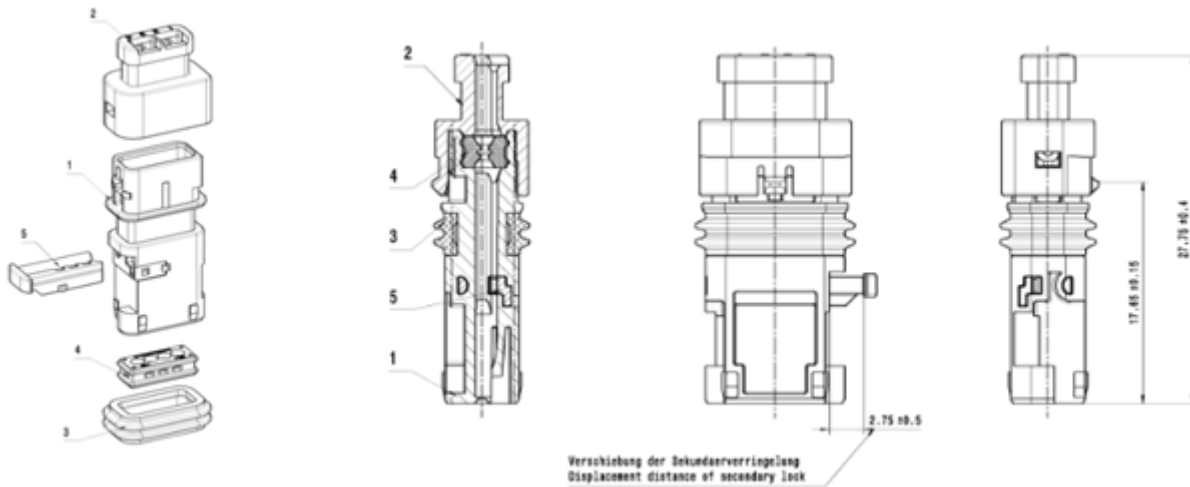

The coding and pinout shall be identical for all variants (Left/Right).

The pin coating shall be silver (Ag)

### 2.6.2 Connector Pinout

ID: 161920	State: Released
------------	-----------------

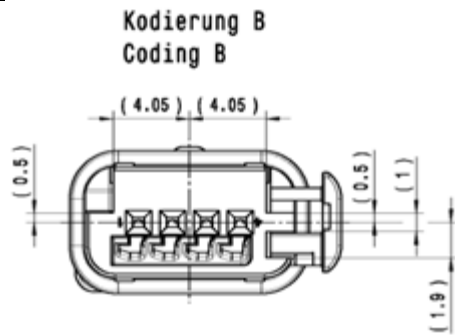

Pin number	Pin Name	Wire Color	Signal Description
A1	Vbatt	Grey	KI30 - Power Supply
A2	Gnd	Black	KI31 - Electrical Ground
A3	CAN-H	Blue	CAN -High
A4	CAN-L	Green	CAN -Low

Designed by	Date	Department		
Released by	Designation			
	IMS ID 161711	SAP ID 10 348616	Document version as of April 27, 2017	Pages 12 of 33

## 2.7 Variants

### 2.7.1 Right/Left Variants

ID: 161823	State: Released
------------	-----------------

There shall be 2 mechanicals variants:

- 1 for Right Handle.
- 1 for Left Handle.

These variants shall differ only by the:

- housing & cover shape
- Flex-PCB shape

Left sensor:



Right sensor:



Designed by	Date	Department		
Released by				
	Designation			
	IMS ID 161711	SAP ID 10 348616	Document version as of April 27, 2017	Pages 13 of 33

## 2.8 Electronics Structure and Interface

### 2.8.1 Electronics Block Diagram

ID: 161781 State: Released

The Electronics shall be compliant with the following Block Diagram.

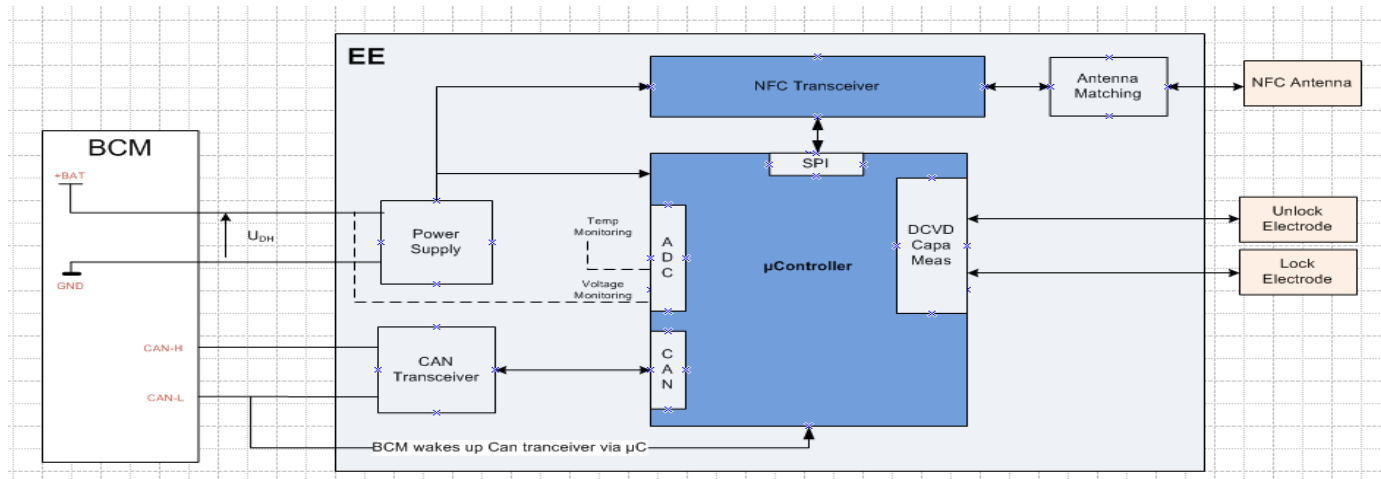

### 2.8.2 Operating Temperature Range

ID: 161782 State: Released

The Electronic Design shall guaranty all electrical parameters over operating Temperature range -40°C to +70°C, unless otherwise stated.

### 2.8.3 Operating Voltage Range

ID: 189713 State: Released

The Electronic Design shall guaranty all electrical parameters over operating Voltage range U<sub>DH</sub> = 8V to 16V, unless otherwise stated.

### 2.8.4 Peak Power Consumption

ID: 161784 State: Released

The Electronic Design shall guarantee the following peak power consumption:

Parameter	Description	Min	Typ	Max	U.	Comments
I <sub>qpkOFF</sub>	Peak Quiescent Current		300	400	mA	µController Awake, NFC polling

Designed by	Date	Department	
Released by			
	Designation		
	IMS ID 161711	SAP ID 10 348616	Document version as of April 27, 2017
		Pages 14 of 33	

						CAN On
--	--	--	--	--	--	--------

Designed by		Date	Department	
Released by		Designation		
	IMS ID	SAP ID	Document version as of	Pages
	161711	10 348616	April 27, 2017	15 of 33

### 2.8.5 Sleep Power Consumption

ID: 161785 State: Released

The Electronic Design shall guarantee the following power consumption in Sleep Mode:

Parameter	Description	Min	Typ	Max	U.	Comments
Iq_low	Quiescent Current in Sleep Mode			67	µA	µController in Sleep Mode, No NFC polling No Capacitive Measurement CAN in Sleep Mode

### 2.8.6 Current Consumption

ID: 161866 State: Released

Parameter	Description	Min	Typ	Max	U.	Comments
IqOFF	Average Dark current	200 TBC	300	500 TBC	µA	Unlock Capacitive Polling @ 20 ms Lock Capacitive Polling @ 70 ms NFC Polling @ 100 ms

### 2.8.7 CAN Voltage Range

ID: 161783 State: Released

The Electronic Design shall guaranty the CAN functionality (communication possible) over operating Voltage range UDH = 6V to 18V.

In case voltage exceed 18V, CAN shall not be operational more than 1 minute.

In case voltage exceed 26V, CAN shall stop immediatly the CAN communication.

Overvoltage and undervoltage are manged by self check algorithm. Thresholds have tolerances up to 27.5V.

See [Requirement 171350](#)

Designed by	Date	Department	
Released by			
	Designation		
	IMS ID 161711	SAP ID 10 348616	Document version as of April 27, 2017
		Pages 16 of 33	



### 3 Misuse Protections

After 20 lock/unlock activations in less than 10 seconds the sensor deactivates capa functions for 30s.

After 20 NFC activations with wrong TAG in less than 10 seconds the sensor deactivates NFC function for 30s.

Designed by		Date	Department	
Released by		Designation		
	IMS ID	SAP ID	Document version as of	Pages
	161711	10 348616	April 27, 2017	17 of 33

## 4 Communication

The DHS communicates detections ( lock/unlock/NFC) and status ( diagnosis) on CAN

### 4.1 CAN Communication Protocol

ID: 161957	State: Released
------------	-----------------

The DHS shall communicate with the BCM over a CAN High Speed network (500 kbits/s)

#### 4.1.1 Lock Detection Message

ID: 162063	State: Released
------------	-----------------

If the DHS is in DETECTION or END\_OF\_DETECTION state on Lock, it shall set the following data on the CAN Output :

If the DHS is in Prox range:

Frame ***NFC\_TGS\_01 : KY\_Schliessen\_Annaeherung = 0x1***

If the DHS is in Touch range:

Frame ***NFC\_TGS\_01 : KY\_Schliessen\_Beteatigung = 0x1***

Otherwise, these signals shall be set to **0x0**.

#### 4.1.2 Unlock Detection Messages

ID: 162061	State: Released
------------	-----------------

If the DHS is in DETECTION or END\_OF\_DETECTION state on Unlock, it shall set the following data on the CAN Output :

If the DHS is in Prox range:

Frame ***NFC\_TGS\_01 : KY\_Oeffnen\_Annaeherung = 0x1***

If the DHS is in Touch range:

Frame ***NFC\_TGS\_01 : KY\_Oeffnen\_Beteatigung =0x1***

Otherwise, these signals shall be set to **0x0**.

Designed by	Date	Department		
Released by				
	Designation			
	IMS ID 161711	SAP ID 10 348616	Document version as of April 27, 2017	Pages 18 of 33

### 4.1.3 DHS Error Message

ID: 167002	State: Released
------------	-----------------

If the DHS has detected any error, it shall pre-set the following data on the CAN Output.

The Frame **NFC\_TGS\_01** is sent when an active condition is set (AC) or wake up condition (WUC) is detected (if NM\_NFC\_TGS\_NM\_Activ\_KL\_15 (AC) set to 1 on or NM\_NFC\_TGS\_NM\_Activ\_Diagnose (AC) set to 1 or NM\_NFC\_TGS\_NM\_activ\_Auth (AC & WUC) set to 1 or NM\_BCM2\_Car\_WakeUp (WUC) set to 1).

Frame **NFC\_TGS\_01 : NFC\_TGS\_Fehler = 0x0 - No error**

Frame **NFC\_TGS\_01 : NFC\_TGS\_Fehler = 0x1 - DHS Internal error**

Frame **NFC\_TGS\_01 : NFC\_TGS\_Fehler = 0x2 - Antenna error**

Frame **NFC\_TGS\_01 : NFC\_TGS\_Fehler = 0x4 - Undervoltage**

Frame **NFC\_TGS\_01 : NFC\_TGS\_Fehler = 0x8 - Overvoltage**

Frame **NFC\_TGS\_01 : NFC\_TGS\_Fehler = 0x16 - Overheating**

Designed by	Date		Department	
	Released by			
	Designation			
	IMS ID 161711	SAP ID 10 348616	Document version as of April 27, 2017	Pages 19 of 33

### 4.3 NFC Communication

#### 4.3.1 NFC type

ID: 167097	State: Released
------------	-----------------

The interface to smartphone / smartcard is defined according to ISO 14443A.

Once a PICC has been detected, the DHS shall enter the NFC RF discovery mode.

The DHS shall search for all allowed devices, and communicate with PICC type : NFC A Type 4.

#### 4.3.2 Actuator test

ID: 191483	State: Released
------------	-----------------

When DHS receive the frame **NFC\_01** with signal **Stellgliedtest\_NFC set**, the DHS shall perform the actuator test requirement as described below :

1. It shall turn on the antenna for at least  $p\_t\_tgs\_actuator\_test$  s and look for an external device with RF discovery polling rate as short as possible
2. If it finds an appropriate counterpart (NFC-A Type 4), it shall activate and send the SELECT command.
3. It shall feedback the result by changing the parameter "authenticated NFC-counterpart"

The DHS Application shall execute the acutator test (when requested) at any time regardless of the Misuse or K15 State and ESM.

It is required that the field is turned on during the complete duration of the actuator test.

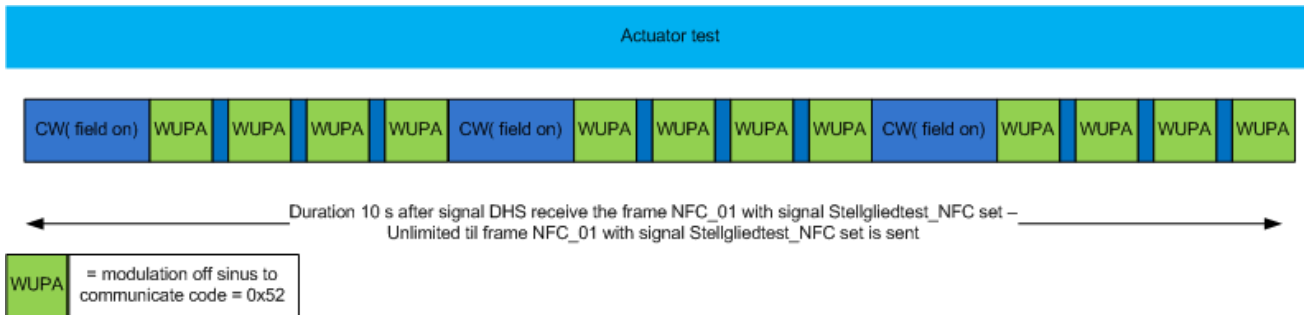

REQA is replaced by WUPA to ensure several communication possible whereas field is kept on.

The DHS shall stop the actuator test if:

Designed by	Date	Department	
Released by			
	Designation		
	IMS ID 161711	SAP ID 10 348616	Document version as of April 27, 2017
		Pages 20 of 33	

- receives the signal Stellgliedtest\_NFC = 0 before the expiration of the timeout p\_t\_tgs\_actuator\_test
- the timeout of p\_t\_tgs\_actuator\_test s expires

Name	Message	Multiplexing/G...	Startbit	Leng...	Byte Order
Stellgliedtest_NFC	NFC_01	-	14	1	Intel
NFC_ESM_aktivieren	NFC_01	-	15	1	Intel
ZV_auf_NFC	NFC_01	-	22	1	Intel
ZV_zu_NFC	NFC_01	-	23	1	Intel
NFC_Front_Verr_Authorisiert	NFC_01	-	56	1	Intel
NFC_Front_Entr_Authorisiert	NFC_01	-	57	1	Intel
NFC_HD_Verriegelung_Authorisiert	NFC_01	-	58	1	Intel
NFC_HD_Entriegelung_Authorisiert	NFC_01	-	59	1	Intel
NFC_aktiv	NFC_01	-	60	1	Intel
NFC_Laden_unterbrechen	NFC_01	-	61	1	Intel
NFC_FT_Entriegelung_Authorisiert	NFC_01	-	62	1	Intel
NFC_FT_Verriegelung_Authorisiert	NFC_01	-	63	1	Intel

Designed by	Date	Department	
Released by			
	Designation		
	IMS ID 161711	SAP ID 10 348616	Document version as of April 27, 2017
		Pages 21 of 33	

## 5 Detection area

### 5.1.1 Unlock Detection Area

ID: 161859	State: Released
------------	-----------------

The Unlock detection area shall be limited to the designated area :

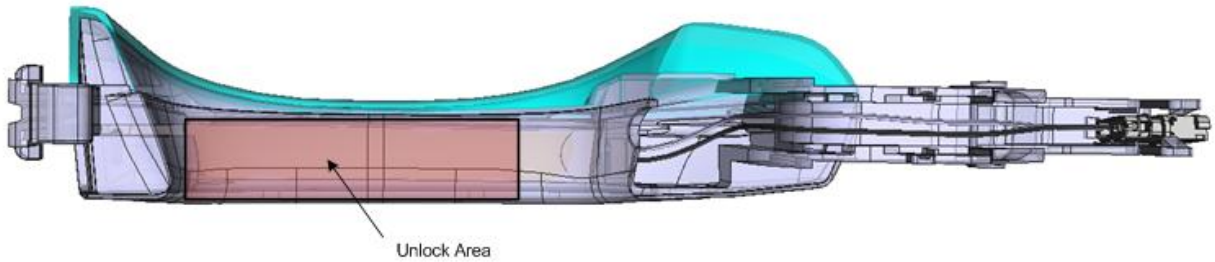

### 5.1.2 Lock Detection Area

ID: 161860	State: Released
------------	-----------------

The Lock detection area shall be limited to the designated area :

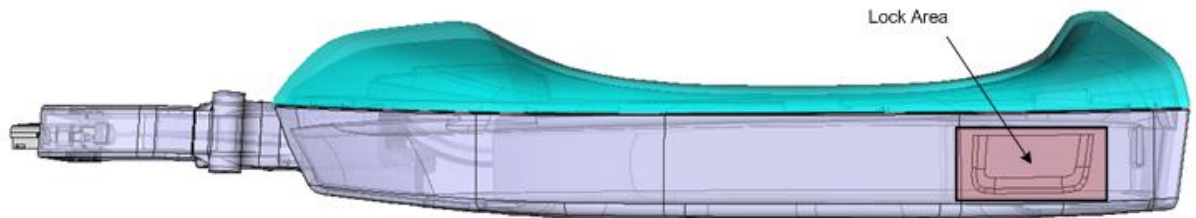



### 5.1.3 NFC Detection Area

ID: 166779	State: Released
------------	-----------------

The NFC detection area shall be limited to the designated area :

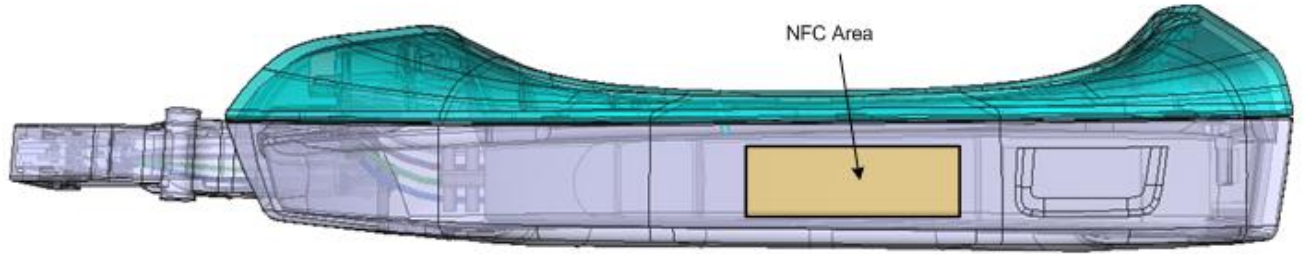
Designed by	Date	Department		
Released by				
	Designation			
	IMS ID 161711	SAP ID 10 348616	Document version as of April 27, 2017	Pages 22 of 33



Designed by		Date	Department	
Released by				
	Designation			
	IMS ID 161711	SAP ID 10 348616	Document version as of April 27, 2017	Pages 23 of 33

## 6 Homologation setup

### 6.1 General Test conditions

**General test conditions valid for all tests :**

- All materials within 100mm around the door handle sensor during the test process (includes Handle fixations - “Sensor fixture” / “Holder”, sockets, base plate, ... -, actuation system –robot, arms, ...-, tester mechanics, ...) shall be made of non conductive material and as electrostatic neutral as possible (ie PEEK or PA66 GF30) in order to avoid influence on detection distance.
- Conductive environment (Robot, arms, jig walls, etc ...) shall be at least 100mm away from Door Handle Assembly throughout the test sequence (except for Targets themselves).
- The connector positions, and then the bed-of-nails, shall be 100 mm away from the sensitive areas during the test.
- The DHS shall have its dedicated power supply. This power supply shall be a low noise linear power supply (switch mode power supplies are prohibited)
- No noise shall be visible by oscilloscope on DHS supply line.

### 6.2 Material provided by Continental

- 5 DHS Left number 84, 30,67,26,34
- 5 DHS right number 42, 13,9,15,48
- Test box with usage described below
- Wires / connector
- Tag for NFC detection

### 6.3 DHS detection tracking

In order to check DHS signal during homologation tests, a specific test box is provided by Continental.

Designed by		Date	Department	
Released by		Designation		
	IMS ID	SAP ID	Document version as of	Pages
	161711	10 348616	April 27, 2017	24 of 33





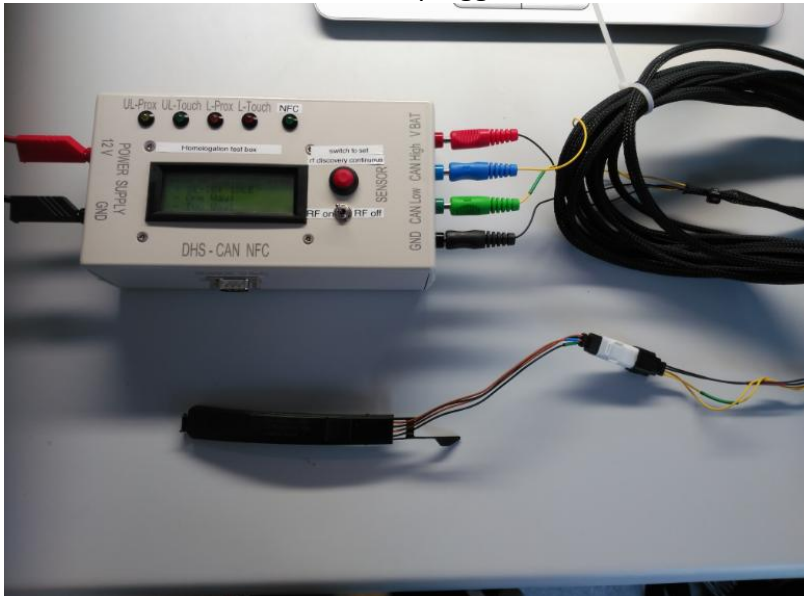

### 6.3.1 DHS connection instructions:

Global overview when sensor is plugged to testbox:



Designed by		Date	Department	
Released by		Designation		
	IMS ID	SAP ID	Document version as of	Pages
	161711	10 348616	April 27, 2017	25 of 33



Designed by		Date	Department	
Released by		Designation		
	IMS ID	SAP ID	Document version as of	Pages
	161711	10 348616	April 27, 2017	26 of 33

Transmittal, reproduction, dissemination and/or editing of this document as well as utilization of its contents and communication thereof to others without express authorization are prohibited. Offenders will be held liable for payment of damages. All rights created by patent grant or registration of a utility model or design patent are reserved.

Supply test box with 12V.

Plug DHS Vbat and GND to corresponding Vbat and GND input on test box:



Plug DHS CAN low and Can High to corresponding CAN low and Can High input on test box with color corresponding plugs:



Designed by		Date	Department	
Released by		Designation		
	IMS ID	SAP ID	Document version as of	Pages
	161711	10 348616	April 27, 2017	27 of 33

### 6.3.2 Test box signals description:

LEDs are available to check visually if sensor is working.



For each lead an output is available and can be connected directly to any recorder ( oscilloscope,...). High level means no detection, low level means detection.

Below example with lock touch : L\_Touch output is plugged to oscilloscope – GND also :

Designed by		Date	Department	
Released by		Designation		
	IMS ID	SAP ID	Document version as of	Pages
	161711	10 348616	April 27, 2017	28 of 33

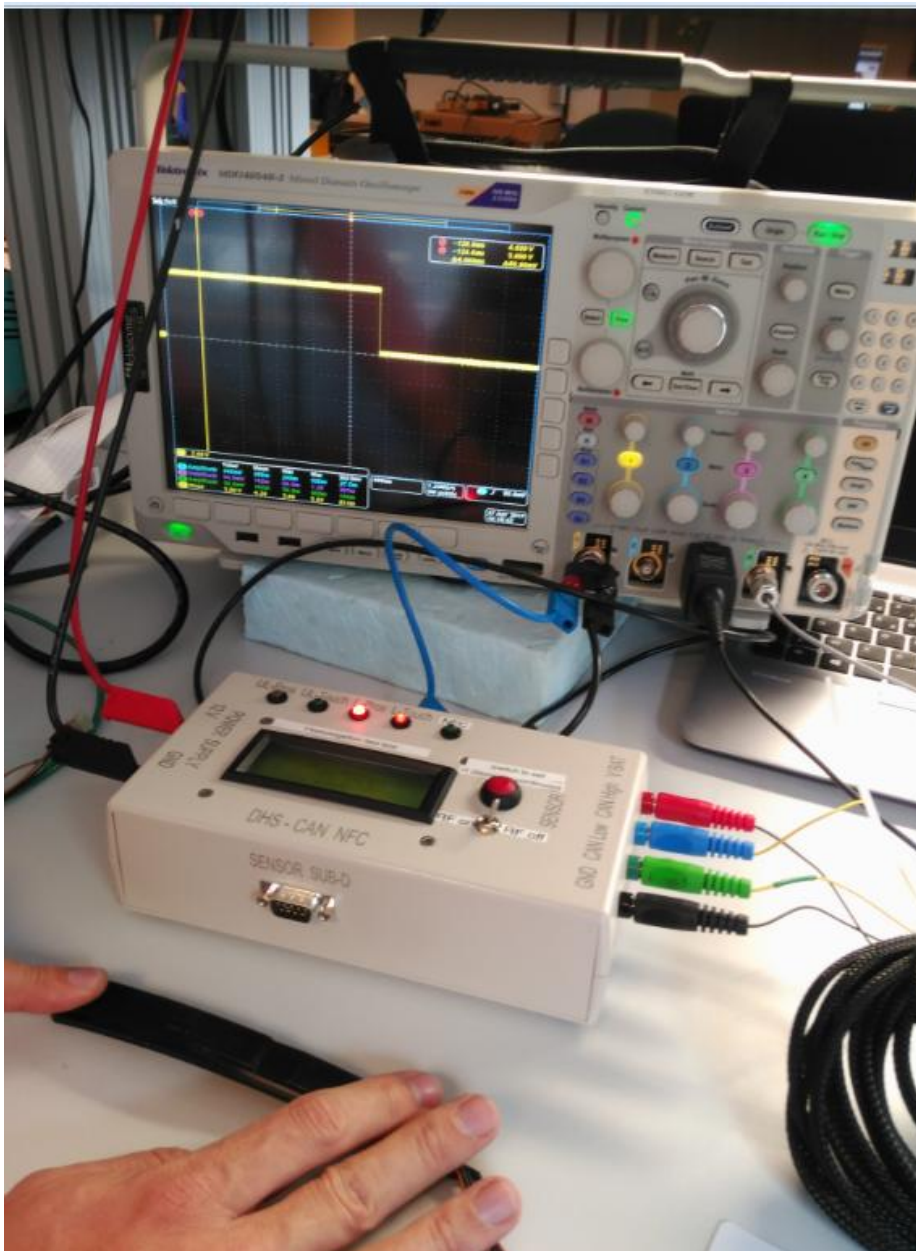



Designed by		Date	Department
Released by			
	Designation		
	IMS ID 161711	SAP ID 10 348616	Document version as of April 27, 2017
			Pages 29 of 33

**Unlock prox/touchdetection : touch hand in unlock area :**

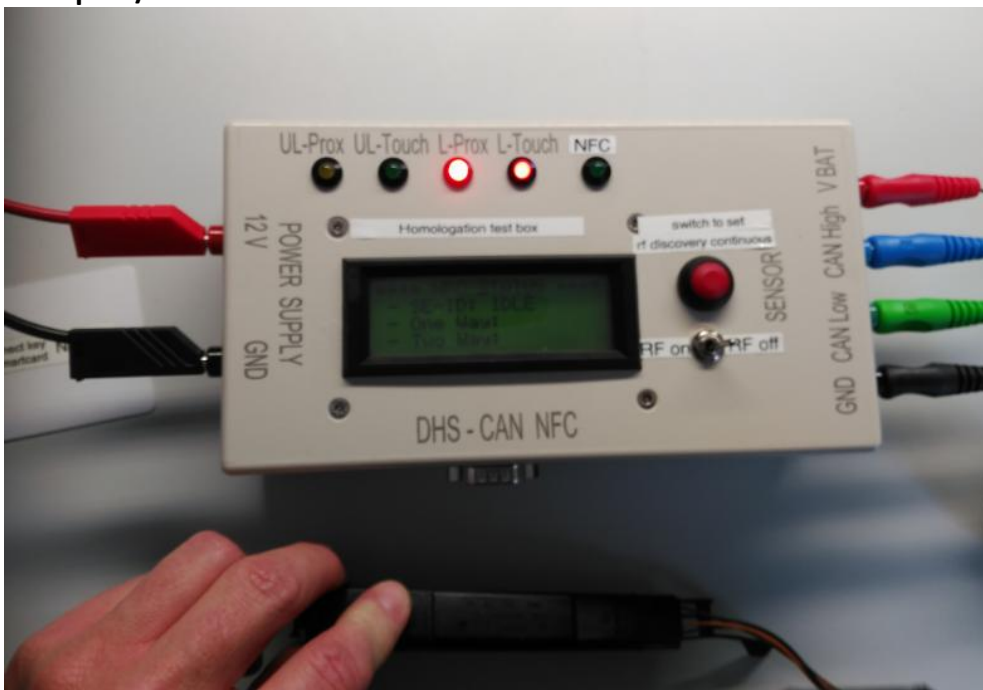

**Lock prox/touchdetection : touch hand in unlock area :**



Designed by		Date	Department
Released by		Designation	
	IMS ID 161711	SAP ID 10 348616	Document version as of April 27, 2017
			Pages 30 of 33

NFC detection : approach TAG against NFC area : message on test box = “SE-ID:OK”

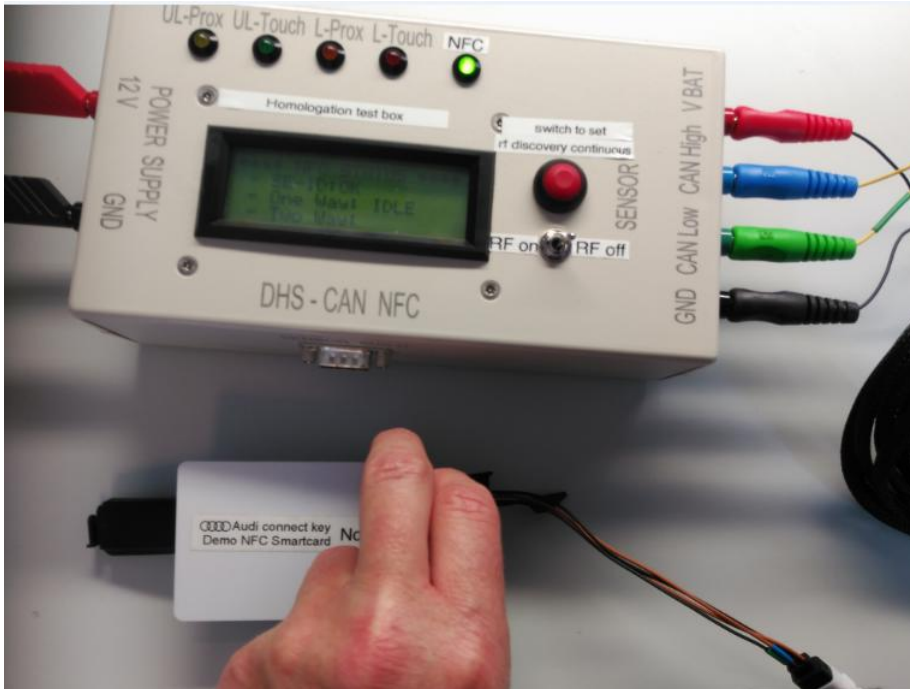

Designed by	Date	Department		
Released by				
	Designation			
	IMS ID 161711	SAP ID 10 348616	Document version as of April 27, 2017	Pages 31 of 33

**Before to start any test, check for each LED and corresponding output that sensor is working fine:**

- touch lock area with thumb for at least 300 ms => check lock prox and lock touch function
- touch unlock area with hand for at least 200 ms => check unlock prox and unlock touch function
- approach TAG against NFC area => check NFC function

**6.3.3 Test box function:**

To set the sensor in “normal mode”, as it is in vehicle configuration without communication with BCM, let the switch in position RF-OFF.

To set the sensor in “RF Discovery mode”, set the switch in position RF-ON. The sensor will send continuous WUPA as described in chapter “actuator test”.

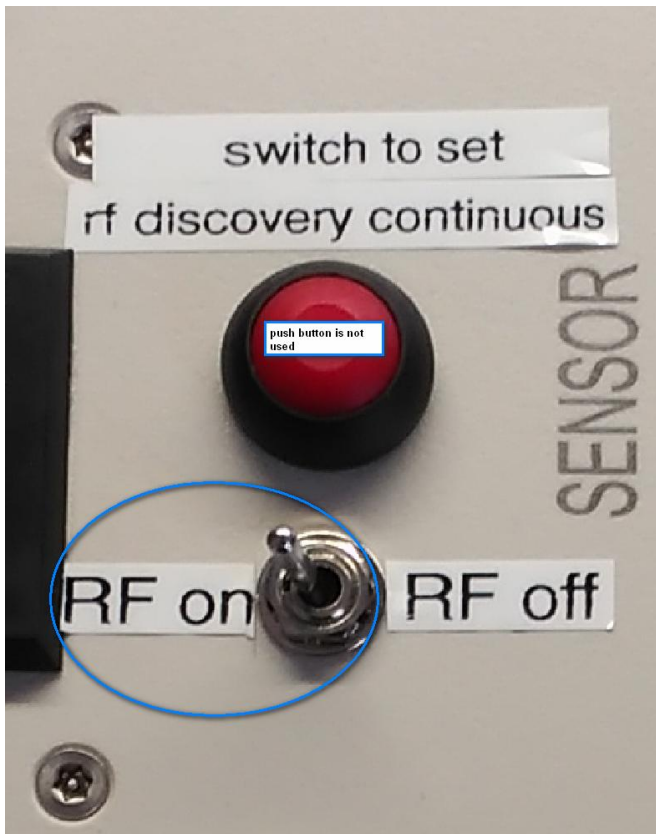

To check no loss of detection Tag provided by continental shall lay against the DHS in front of NFC Area as describe in chapter”NFC detection area”.

Designed by		Date		Department	
Released by		Designation			
		IMS ID		SAP ID	
		161711		10 348616	
		Document version as of		Pages	
		April 27, 2017		32 of 33	



To exit the sensor from “RF Discovery mode”, set the switch in position RF-OFF. The sensor will exit from this mode to normal mode in about 1s.



Designed by	Date	Department		
Released by				
	Designation			
	IMS ID 161711	SAP ID 10 348616	Document version as of April 27, 2017	Pages 33 of 33

## **FCC Regulatory notices**

### **Modification statement**

Continental Automotive GmbH has not approved any changes or modifications to this device by the user. Any changes or modifications could void the user's authority to operate the equipment.

### **Interference statement**

This device complies with Part 15 of the FCC Rules. Operation is subject to the following two conditions: (1) this device may not cause interference, and (2) this device must accept any interference, including interference that may cause undesired operation of the device.

### **Wireless notice**

This device complies with FCC radiation exposure limits set forth for an uncontrolled environment and meets the FCC radio frequency (RF) Exposure Guidelines. This transmitter must not be co-located or operating in conjunction with any other antenna or transmitter.

### **FCC Class B digital device notice**

This equipment has been tested and found to comply with the limits for a Class B digital device, pursuant to part 15 of the FCC Rules. These limits are designed to provide reasonable protection against harmful interference in a residential installation. This equipment generates, uses and can radiate radio frequency energy and, if not installed and used in accordance with the instructions, may cause harmful interference to radio communications. However, there is no guarantee that interference will not occur in a particular installation. If this equipment does cause harmful interference to radio or television reception, which can be determined by turning the equipment off and on, the user is encouraged to try to correct the interference by one or more of the following measures:

- Reorient or relocate the receiving antenna.
- Increase the separation between the equipment and receiver.
- Connect the equipment into an outlet on a circuit different from that to which the receiver is connected.
- Consult the dealer or an experienced radio/TV technician for help.