

User Manual / Functional Description

of the

Siemens VDO

Tire Pressure Generation 1B-EP wheel unit

Type

S 120 123 007

1. SYSTEM OVERVIEW

The tire pressure monitoring system (referred as TG for Tire Guard) consists of the following units:

- Tire guard transmitter type S 120 123 007 which includes an integrated pressure, temperature and acceleration sensor and a RF transmitter.
- RF receiver unit which includes a receiver (not described in this document)

The Tire Guard system monitors a vehicle's tire pressure whilst driving or stationary. An electronic unit (wheel unit) inside each tire, mounted to the valve stem, periodically measures the actual tire pressure. By means of RF communication, this pressure information is transmitted to the RF receiver/decoder.

In stationary mode, the pressure, temperature and acceleration are measured about every minute and emission of RF frames occurs only if pressure variation, higher than a threshold, is detected (leakage detection).

When the vehicle starts moving, the Tire Guard transmitter enters the driving mode. Then the wheel unit measures and transmits data every minute. The wheel unit will remain in driving mode for a period of 15 minutes after the vehicle is stopped. After this period has elapsed, the wheel unit returns to stationary mode.

If, during any measurement period in driving mode, the pressure leakage is detected (difference compared to the last transmitted pressure value), a re-measure will occur after 1s (during 8s) taking in account the latest pressure value emitted as reference value. If the pressure continues changing, an additional transmission will be sent.

The circuit within the wheel unit monitors the battery every time a pressure measurement is taken. A "Low Battery" function code will be sent when the battery voltage within the wheel unit is below a pre-selected level.

2. BLOCK DIAGRAM

The block diagram below shows the main electronic units of the wheel unit:

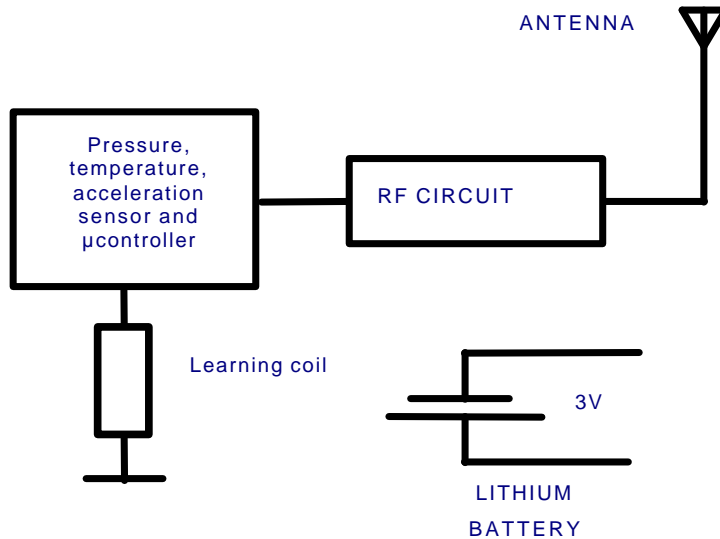

3. VARIANTS

Siemens type designation	Remarks
S 120 123 007	Transmitter 315 MHz

4. TYPICAL USAGE PATTERN

72 burst in 24 hours because 1 burst is emitted every minute in normal condition.

0.014 seconds per frame and 6 frame per burst

- total transmission duration of 6.2 seconds within 24 hours

Transmitter ON 0.26 seconds / hour

Transmitter OFF 3599.74 seconds / hour

Duty Cycle: $T_{ON} / T_{(ON+OFF)} \times 100\% = 0.26 / 3600 \times 100\% = 0.007\%$

5. TECHNICAL DESCRIPTION

Carrier frequency:	315 MHz
Frequency shift:	None
Number of channels:	1
Method of frequency generation:	PLL
Type of modulation:	ASK
Rated Output Power:	< 10 mW
Antenna:	External (Valve antenna)
Voltage supply:	1 Lithium battery 3V (CR2450)
Voltage supply range :	2,1 up to 3,2V

6. LABEL DESIGN USA, CANADA

Siemens VDO
S120123007

FCC ID:KR5S120123007
IC:267T-20123007

owner manual: warning statement

This device complies with part 15 of the FCC Rules and RSS-210. Operation is subject to the following two conditions: (1) This device may not cause harmful interference, and (2) this device must accept interference received, including interference that may cause undesired operation.

Note:

Changes or modifications not expressly approved by the manufacturer could void the user's authority to operate the equipment.