

7" In-Wall Touch Screen with Camera Installation Guide



Introduction

The Control4® 7" In-Wall Touch Screen with Camera offers complete system control in an elegant and compact design. This Touch Screen is equipped with a capacitive Touch Screen and four (4) programmable shortcut buttons plus Audio and Video Intercom (with a built-in camera) using SIP.

The available power options are AC power or Power-over-Ethernet (PoE); the network options are WiFi or Ethernet connections. This Touch Screen supports new construction or retrofit installations.

- **AC.** AC power is used to power the Touch Screen when using an Ethernet or WiFi network connection.
- **PoE.** PoE is used to power the Touch Screen when using an Ethernet or WiFi network connection.

The following table shows the available network options with power.

- Ethernet with PoE
- Ethernet with AC
- WiFi with AC



NOTE: Video Intercom using 802.11b is not recommended or supported for Video Intercom. Control4 recommends Wireless-N for Video Intercom. See “Wireless Network Limitations” and “Power and Network Installation Options.”

- **Option 1: Ethernet with PoE.** The Ethernet network connection is provided through the PoE Injector. No additional wiring is needed.
- **Option 2: Ethernet with AC.** Connect the Touch Screen to one of the RJ-45 LAN ports on the gateway/router using the RJ-45 Ethernet cable.
- **Option 3: WiFi with AC.** The internal WiFi will communicate with the LAN's WAP. If the LAN has a WAP set up, no additional wiring is needed.

Supported Models

- **C4-TW7C0- BL** - 7 Inch Wall Mount Capacitive Touch Screen with Camera, Ethernet/WiFi, PoE/ Universal Voltage, Black
- **C4-TW7C0- WH** - 7 Inch Wall Mount Capacitive Touch Screen with Camera, Ethernet/WiFi, PoE/ Universal Voltage, White

Associated SKUs:

- **C4-TSWMC5-EG-WH** - 5" In-Wall Touch Screen, White (no camera)
- **C4-TSWMC7-EG-WH** - 7" In-Wall Touch Screen, White (no camera)
- **C4-TSWMC5-EG-BL** - 5" In-Wall Touch Screen, Black (no camera)
- **C4-TSWMC7-EG-BL** - 7" In-Wall Touch Screen, Black (no camera)

Box Contents

Carefully unpack the contents of the box, and make sure the following items are included. If any item is missing or damaged, please contact your Control4 Reseller.

- 7" In-Wall Touch Screen with Camera
- Power box (used to power the Touch Screen)
- Two (2) screws to attach the power box
- Warranty card

7" In-Wall Touch Screen with Camera Installation Guide

Accessories

- **PoE.** Control4 Power over Ethernet Injector, sold separately (AC-POE1-B).
- **Back Box Options.** There are four (4) back box options available for this Touch Screen's installation. Metal and plastic back boxes are available for new construction or retrofit installations.

5" and 7" In-Wall Touch Screen Back Box Kits - New Construction

- 5" and 7" In-Wall Touch Screens Wall Box, New Construction, Plastic (C4-NWB57C-P)
- 5" and 7" In-Wall Touch Screens Wall Box, New Construction, Metal (C4-NWB57C-M)

5" and 7" In-Wall Touch Screen Back Box Kit - Retrofit

- 5" and 7" In-Wall Touch Screens Wall Box, Retrofit, Plastic (C4-RWB57C-P)
- 5" and 7" In-Wall Touch Screens Wall Box, Retrofit, Metal (C4-RWB57C-M)

See the Control4 *5" or 7" In-Wall Touch Screen Wall Box Installation Guide - New Construction* or *5" or 7" In-Wall Touch Screen Wall Box Installation Guide - Retrofit* for back box installation details.

Specifications

Screen	7" 16:9 wide VGA Color LCD Module Resolution: 800 x 480 Camera: 640 x 480 VGA Brightness: 350 nits
Wireless	Built In IEEE802.11 b/g/n Wireless LAN Integral Antenna (b/g/n supported) Authentication: WEP, WPA, WPA2

Dimensions (H x W x D)	4.88" x 7.2" x .60" (124 mm x 183 mm x 15.24 mm)
Weight	1.15 lbs. (.52 kg)
Shipping Weight	1.8 lbs. (.81 kg)
Network	WiFi (802.11 b/g/n) wireless access point (WAP) already configured to communicate with a Control4 Controller (e.g., HC-800). Wireless-N is recommended for Video Intercom. Notes: (1) Intercom usage. 802.11b is not recommended or supported for Video Intercom. (2) Wireless-N is recommended for Video Intercom. Even with Wireless-N, broadcasting to several devices will degrade Video Intercom response time and images. Broadcasting to additional devices will further degrade performance. See "Wireless Network Limitations."

Requirements

To install the 7" In-Wall Touch Screen with Camera, Control4 requires the following:

- A Home Controller fully installed and configured with a Control4® system.
- Control4 7" Touch Screen custom back box installed (OS 2.2.1 or later). See "Accessories."
- **If using Ethernet with PoE power:**
 - Ethernet network installed and available that includes a gateway/router/switch
 - Control4 PoE Injector (model #AC-POE1-B) or another third-party PoE Injector or switch (certified to UL/ANSI standards).
 - Two (2) Ethernet CAT5 cables: (1) one that runs from the Ethernet gateway/router/switch to the PoE Injector/switch and (2) one that runs from the PoE Injector/switch to the Ethernet connection in the Touch Screen's back box.
- **If using Ethernet with AC power:**
 - Ethernet network installed and available that includes a gateway/router/switch
 - Access to in-wall AC power (a neutral connection is required)
 - One (1) Ethernet CAT5 cable that runs from the Ethernet gateway/router/switch to the Touch Screen
 - A 14-gauge electrical wire long enough to pull between the Touch Screen and the power source
- **If using wireless with AC power:**
 - Wireless network (WiFi 802.11 b/g/n) installed and available with a wireless access point (WAP)
 - Access to in-wall AC power (a neutral

connection is required)

- A 14-gauge electrical wire long enough to pull between the Touch Screen and the power source

Front and Rear Panel Descriptions

Front View

Figure 1. Front View - 7" In-Wall Touch Screen

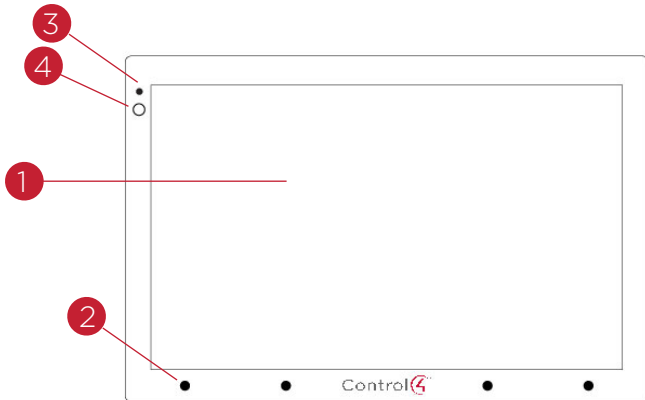

- 1 Display.** 7" viewing area, Touch Screen with 800 x 480 resolution.
- 2 Shortcut buttons (4).** For custom programming; to initiate an action or sequence of actions. Use Composer Pro or Composer HE to configure these buttons.
- 3 Green LED.** Lets you know the camera is on.
- 4 Camera.** For Video Intercom calls.

Dimensions

- **Front dimensions.** 7" Touch Screen (H x W x D): 4.88" x 7.2" x .60" (124 mm x 183 mm x 15.24 mm)
- **Back box dimensions.** 7" Touch Screen (H x W x D): 2.7" x 4.1" x 2.4" (68 mm x 104 mm x 61 mm)
- **Power box dimensions.** 7" Touch Screen (H x W x D): 2.8" x 4.5" x 1.8" (71 mm x 114 mm x 46 mm)

Touch Screen Removal

Use the small hole located under the Touch Screen to remove the Touch Screen from the wall (for details, see Figure 10 in "Troubleshooting").

Back View

Figure 2. Back View - 7" In-Wall Touch Screen with Camera and Power Box

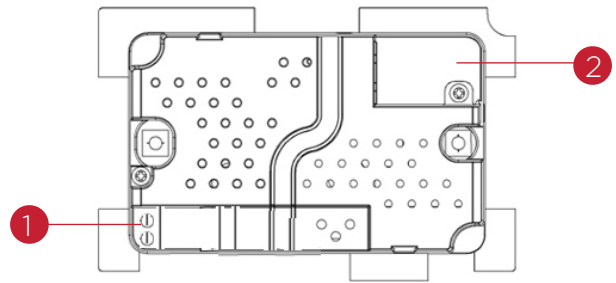

- 1 Wire Connection.** Hot (H) uses Black wire; Return (R) uses White wire.
- 2 RJ-45 port for Ethernet Connection.** Ethernet port available for either a standard Ethernet source that provides network communication only OR a PoE source that provides power to the device and network communication.

Touch Screen Placement

Place the Touch Screen in a convenient location at eye level, typically near the entrance of the room, approximately 57 to 61 inches (145 cm to 155 cm) from the floor (see Figure 3).



NOTE: Consider the camera on the panel and the height of the people in the home who will use the camera for Video Intercom.

Figure 3. Touch Screen Placement

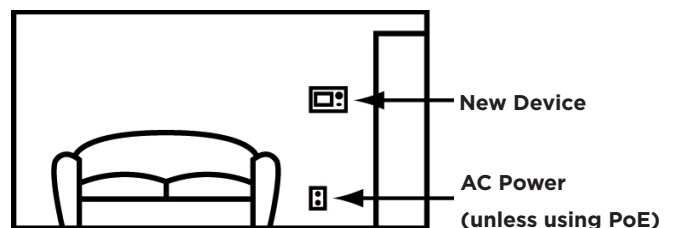

LED Indicator

The LED on the Touch Screen indicates the camera status of the camera and booting information as described in the next table.

Camera LED Color/ State	Touch Screen Status
Off	- Camera is off
Green	- Camera is on
Green (blinks slowly)	- Booting up
Green (blinks rapidly)	- Restoring (during a factory restore)

Installation

WARNING! Before installing the Touch Screen, switch off the circuit breaker or remove the fuse from the fuse box.

AVERTISSEMENT! Pour l'endroit où vous installez l'écran tactile, coupez le disjoncteur ou enlevez le fusible de la boîte de fusible.

IMPORTANT! Before you can complete the instructions below, you must have a 7" Touch Screen back box installed according to the documentation provided in the back box kit. See "Accessories" for details.

IMPORTANT! En coupant l'ouverture pour la boîte de mur, ne coupez pas l'ouverture trop grande. Soyez conservateur et agrandissez-avec précaution la comme nécessaire. Voyez que <<Accessories>>.

IMPORTANT! When cutting the opening for the back box, DO NOT cut the opening too large. Be conservative and cautiously enlarge it as needed.

IMPORTANT! En coupant l'ouverture pour la boîte de mur, ne coupez pas l'ouverture trop grande. Soyez conservateur et agrandissez-avec précaution la comme nécessaire.

Power and Network Installation Options

This device uses an Ethernet or WiFi network connection, and can be powered using PoE or AC power.

Choose one of the following options to install the power and network communication.

CAUTION! Do not attempt to use PoE and AC power at the same time. Choose only one power option.

ATTENTION! Ne pas tenter d'utiliser PoE et AC en même temps. Choisir une seule option d'alimentation.

Option 1: Ethernet Connection with a PoE Injector or a Third-Party Injector or Switch

PoE supplies DC power on the Ethernet cable using a PoE Injector (model #AC-POE1-B) or a third-party PoE solution to provide the Touch Screen with power and a network connection. The Touch Screen works with the Control4 PoE Injector or a third-party PoE Injector.

To set up your PoE and Ethernet connection with a PoE Injector, see Figure 4.

- 1 Attach the PoE Injector according to the instructions in your PoE's installation guide if provided. Control4 PoE Injector instructions are provided later in this document.
- 2 Pull the Ethernet cable from that location to where you want to install the Touch Screen.

Figure 4. Ethernet with PoE - Requires Ethernet Connection to PoE Injector

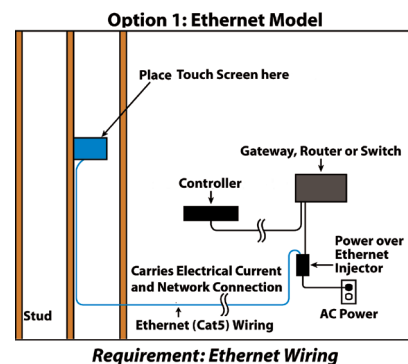

Option 2: Ethernet Connection with AC

The Ethernet is connected directly to the switch (see Figure 5). This power connection requires both neutral and hot connections.

Figure 5. Ethernet - Requires a Connection to Ethernet and AC Power

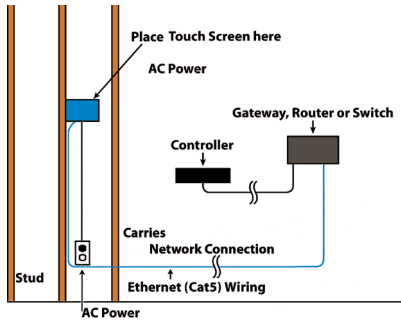

Option 3: WiFi Connection with AC

Place the Touch Screen above a power source, for example, an outlet. Ensure that you have WiFi in the home (see Figure 6).



NOTES: (1) Video Intercom. Although this device supports b/g/n, 802.11 b is not supported for Video Intercom use. (2) Wireless-N is recommended for Video Intercom. See the *Composer Pro User Guide* for details about the 7" In-Wall Touch Screen with Camera properties.

Wireless Network Limitations

Many WiFi Access Points handle Multicasts (WiFi simultaneously sent to multiple devices, for example, when the 7" In-Wall Touch Screen with Camera broadcasts video to all stations) by slowing down transmission speed to the 1 Mb basic rate. This can cause overall WiFi congestion in the WiFi network during the broadcast. Video Intercom response times and images may degrade at each device.

If a home requires a large number of WiFi Video Intercom devices, ensure that you have a robust WiFi network (possibly consisting of multiple access points).

Figure 6. WiFi - Requires AC Power and WAP

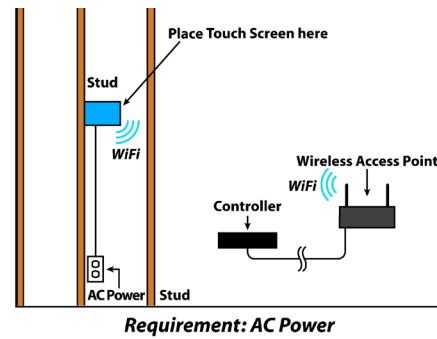

Power Installation

Prepare the plastic power box for installation into the back box by inserting either the Ethernet cable or the AC power cable into the power box (see Figures 7 and 8), and then follow the instructions next.

AC Power Connection

The steps below represent a typical U.S. installation.

- 1 Connect the wires to the AC power source for the Touch Screen according to the national and local electrical codes. Installation may require alternative wires and the use of a terminal block.
- 2 Thread the power cable through the bottom back hole of the back box to the terminal block (see Figure 7).
- 3 Strip the black and white power wire ends to 1/4" as necessary. Using a flathead screwdriver, loosen the screws on the power box's terminal block and connect the power wires to each terminal (see Figure 7).
- 4 Cap the ground wire from the wall if you are using a plastic back box. Attach the ground wire to the back box if using a metal back box.

Figure 7. AC Power Connection

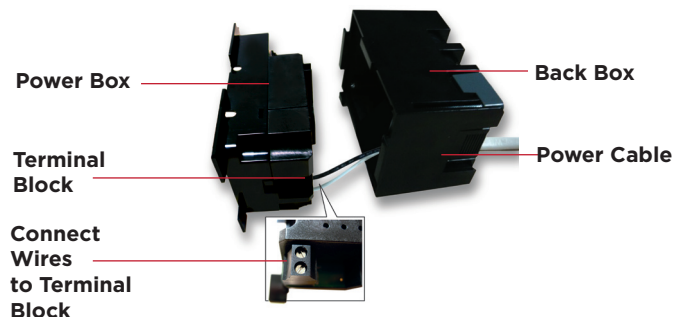

- 5 Align and bend the wires carefully to fit them inside the back box.
- 6 Align and carefully slide the power box into the back box.
- 7 Secure the power box into the back box using the screws provided.

 **NOTE:** Overtightening the power box screws could result in a poor connection between the Touch Screen and the power box and could also cause the Touch Screen to warp.

- 8 Align and slide the back of the Touch Screen into the power box. The Touch Screen is magnetic and should snap into place easily.
- 9 (Optional) To secure the Touch Screen inside the power box, remove the tape covering the bottom security pin (see Figure 10) before attaching the Touch Screen to the power box.

Power Over Ethernet (PoE) Connection

Connect the PoE Injector to power and the network, and then connect it to the power box.

The steps below describe how to install a Control4 PoE Injector.

- 1 Connect the Control4 PoE Injector to an AC outlet using the power cord.
- 2 Connect one of the RJ-45 LAN ports on the gateway/router/switch to the PoE Injector's LAN port using the RJ-45 Ethernet cable.
- 3 Connect the PoE Injector's PWR LAN-OUT port to the RJ-45 Ethernet cable that will be connected to the Touch Screen.
- 4 Pull the Ethernet cable through the top back hole of the back box to the Ethernet connector on the top back of the power box, and then connect it (see Figure 8).
- 5 Align and carefully slide the power box into the back box until the Touch Screen is attached to the power box.

Figure 8. Ethernet Connection

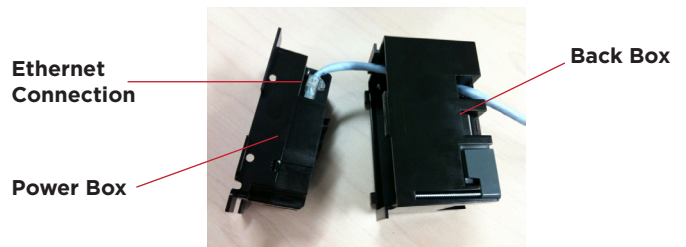

- 6 Secure the power box into the back box using the screws provided.

 **NOTE:** Overtightening the power box screws could result in a poor connection between the Touch Screen and the power box and could also cause the Touch Screen to warp.

- 7 Align and slide the back of the Touch Screen into the power box. The Touch Screen is magnetic and should snap into place easily.
- 8 (Optional) To secure the Touch Screen inside the power box, remove the tape covering the bottom security pin (see Figure 10) before attaching the Touch Screen to the power box.

Configuration

Configure for Wireless

(WiFi only) Connect to a WAP on the Touch Screen (see Figure 9):

Figure 9. Wireless Configuration

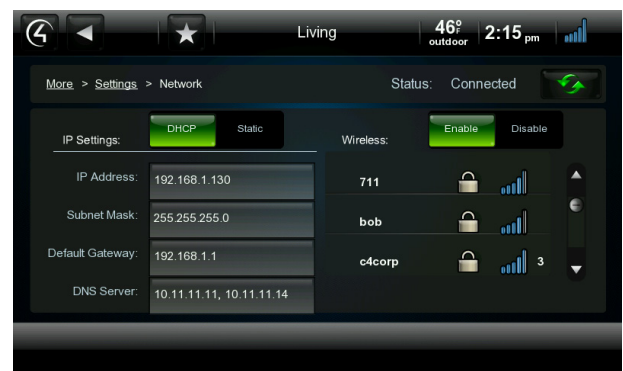

- 1 After initialization, press and hold the large White 4 in the center of the Touch Screen to enter the configuration screen.
- 2 Press the **Network** button on the Touch Screen's

configuration page. The network configuration screen displays.

- 3 Under **Wireless**, select **Enable**. If you don't see the network you want, select **Other**.
- 4 At **Network Name**, select to add the **SSID** or **wireless network** when the keyboard appears. Select **Done**.
- 5 At **Security**, select **None**, **WEP 64**, **WEP 128**, **WPA**, or **WPA2**.
- 6 At **Password**, type the **password** on the keyboard that appears. Press **Done**.
- 7 Select **Connect**. Notice that the IP settings change. The IP address is set to DHCP by default.
- 8 (Optional) If you need to set a static IP address instead, complete the following steps:
 - a On the **Network** page, press **Static**.
 - b Select each box one at a time and type the address: IP Address, Subnet Mask, Default Gateway, Preferred DNS, and Alternate DNS.
 - c When the keyboard appears, type the address, and then press **Done**.
- 9 Press **OK** to return to the **Network** page. You can now connect to a Control4 Director running on a Control4 device on the network.
- 10 Press **OK**.

Configure in Composer Pro

When the Touch Screen is physically installed and appears on the home network, you can add and configure it for the Control4 System using Composer Pro. Choose the **In-Wall 7" Touch Screen V2** driver in Composer and add it to your project.

See the *Composer Pro User Guide* for information about how to add and identify the Touch Screen to the Control4 System.

Troubleshooting

Boot Up

When the device is booting up, it may take 30 seconds or longer before the Green LED turns on. When it turns on, it blinks slowly for a time and then turns off. After that, you will see an image on the Touch Screen.

Restore to Factory Default

If the camera's LED blinks on and off for more than 30 seconds, the device will need to be restored.

To access the Factory Restore switch, you'll first need to remove the Touch Screen.



NOTE: If there's tape on the bottom of the power box, simply lift the Touch Screen off (see Steps 3 through 6). Remove the tape to lock the Touch Screen in place. If there's no tape, the Touch Screen is locked into place. In this case, follow the instructions below.

- 1 Locate the small hole underneath the Touch Screen's faceplate (see Figures 10 - 13).

Figure 10. Touch Screen Underside - Pin and Pinhole

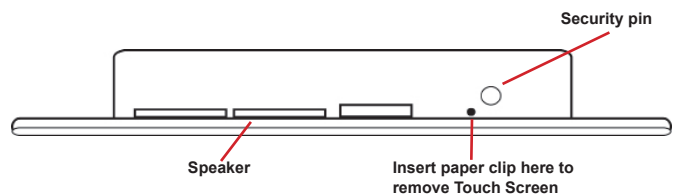

- 2 Using a small unbent paper clip, insert the paper clip straight up and into the small hole (about 1/4") or as far as you can. There's another small hole inside the Touch Screen which the paper clip needs to insert into also (see Figures 11 through 13). You may need to wiggle the paper clip a bit to get it into the second small hole.

Figure 11. Locate Touch Screen Hole

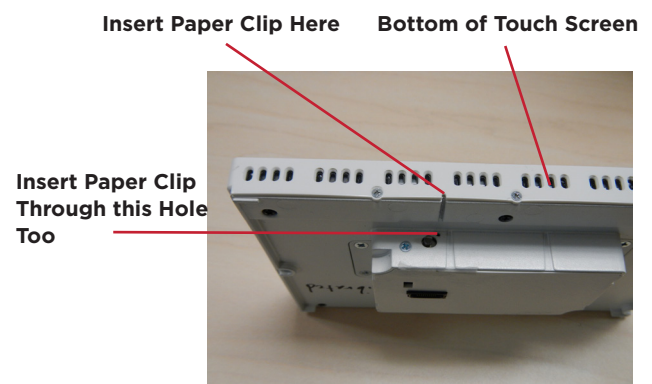
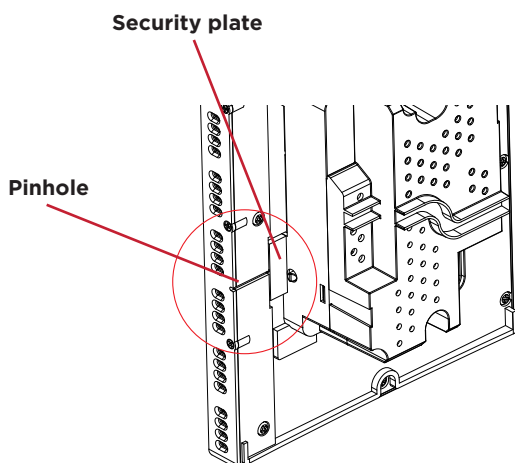

Figure 12. Insert Paper Clip Through Small Hole

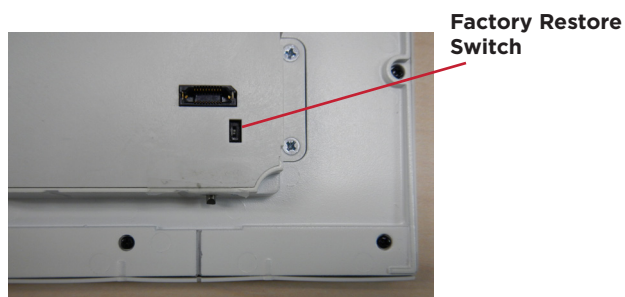

Figure 13. Paper Clip Needs to Engage Release Plate



- 3 With both hands, tilt the bottom of the Touch Screen out and gently remove the Touch Screen.
- 4 On the back of the Touch Screen locate the small switch (see Figure 14).

Figure 14. Factory Restore Switch



- 5 Using the tip of a straight pin or paper clip, change the position of the switch, for example, if the switch is in the down position, push it to the up position. The Touch Screen will then sense the

change on the next power up, and will initiate the restore process.

- 6 When you are finished with the restore, reattach the Touch Screen into the power box in the wall—top first—and then snap the bottom of the Touch Screen back into place.
- 7 The Touch Screen will reboot and the factory default firmware image will be installed. All settings will reset to the factory default settings. See “LED Indicator” for information about how the LED behaves during a factory restore.
- 8 After a restore, the Touch Screen will need to be updated to the same image version of the project (e.g., OS 2.2.2 or later).

Warnings/Considerations

! **WARNING!** The Touch Screen must be protected by an external circuit breaker or a fuse rated at 6A maximum when used in Europe.

AVERTISSEMENT! Pour réduire le risque de feu ou de choc électrique, n'exposez pas cet appareil à la pluie ou à l'humidité.

! **WARNING!** Do not place the Touch Screen near sources of heat or expose to direct sunlight for an extended period of time.

AVERTISSEMENT! Ne placez pas l'unité près des sources de chaleur ou exposition pour diriger la lumière du soleil pendant une période prolongée.

✓ **IMPORTANT!** Do not use pens or sharp objects to navigate or make selections on the Touch Screen. To select an item or scroll through a list, use your fingertip.

IMPORTANT! N'employez pas les stylos ou les objets pointus pour diriger ou pour faire des choix sur l'écran. Pour choisir un article ou un rouleau par une liste, employez votre bout du doigt.

✓ **IMPORTANT!** Improper use or installation can cause DAMAGE OF PROPERTY.

IMPORTANT! L'utilisation ou l'installation inexacte peut causer DAMAGE DE PROPRIÉTÉ.



IMPORTANT! Using this product in a manner other than outlined in this document voids your warranty. Further, Control4 is NOT liable for any damage incurred with the misuse of this product. See "Warranty."

IMPORTANT! Utilisant ce produit en quelque sorte autre que décrit dans ce document vide votre garantie. De plus, Control4 n'est pas responsable d'aucun dommage encouru avec l'abus de ce produit. Voyez que «Warranty.»



WARNING! Install in accordance with all national, state, and local electrical CODES.

AVERTISSEMENT! Installez selon tous les national, état, et codes électriques locaux.



WARNING! This product generates heat. The room must have adequate VENTILATION or the ability to dissipate heat effectively.

AVERTISSEMENT! Ce produit produit de la chaleur. La salle doit avoir à VENTILATION proportionnée ou la capacité d'absorber la chaleur efficacement.



WARNING! This product must be grounded in accordance with the National Electrical Code (NEC) requirements.

AVERTISSEMENT! Ce produit doit être fondu selon les conditions électriques nationales de code (NEC).



WARNING! Use this product only in dry locations.

AVERTISSEMENT! Employez ce produit seulement dans des endroits secs.



CAUTION! This product is for residential use only.

ATTENTION! Ce produit est pour à l'usage résidentiel ou commercial seulement.



MAGNET WARNING! Located within the plastic enclosures of this product are strong (rare earth) magnets that are used to attach the face plate to the electrical box. If someone handling or using the product has a pacemaker, defibrillator, or similar electronic device used for health purposes, avoid close proximity (closer than 20 inches) to the

product until you consult your physician. Magnetic fields can cause damage to magnetic storage media (for example, credit cards, video tapes, computer hard drives, etc). Keep all magnets at least 20 inches away from all types of magnetic media. Certain electronic devices are sensitive to magnetic FIELDS and may be damaged permanently or temporarily disabled if exposed to a magnetic field that is too strong. Consult the owner's manuals of your electronic devices for further information. INGESTED magnets can cause serious injuries and may result in death. If magnets have been ingested (or you suspect they might have been), seek competent medical attention immediately.

AVERTISSEMENT! Aimants! Dans l'emballage en plastique de ce produit sont inclus des aimants très puissants utilisés pour attacher les plaques de surface aux boîtes électriques. Si quelqu'un, manipulant ou utilisant ce produit est muni d'un pacemaker, défibrillateur ou autre dispositif d'ordre médical, il doit éviter de se trouver à proximité (moins de 20 pouces) de ce produit avant d'avoir consulté son médecin. Les champs magnétiques des aimants peuvent endommager le stockage d'information d'ordre magnétique (ex : cartes de crédit, bandes vidéo, disques durs d'ordinateur, etc.) Gardez tous les aimants au moins à 20 pouces de distance de tout type de stockage d'information d'ordre magnétique. Certains dispositifs électroniques sont sensibles aux champs magnétiques et peuvent être endommagés de façon permanente ou être désactivés si ils sont exposés à un champs magnétique trop puissant. Pour plus d'information, consultez le manuel d'utilisateur propre à votre pièce électronique.

Si avalés, les aimants peuvent causer des blessures graves et aussi causer la mort. Si des aimants ont été avalés (ou vous doutez qu'ils ont pu l'être) obtenez les soins médicaux de personnes compétentes immédiatement.

Third-Party Trademarks

Libertas

Libertas Firmware copyright statement for Touch Screens 6/26/09

Copyright (c) 2006, One Laptop per Child and Marvell Corporation.
All rights reserved.

Redistribution, redistribution and use in binary form, without modification, are permitted provided that the following conditions are met:

* Redistributions must reproduce the above copyright notice and the following disclaimer in the documentation and/or other materials provided with the distribution.

* Neither the name of Marvell Corporation nor the names of its suppliers may be used to endorse or promote products derived from this software without specific prior written permission.

* No reverse engineering, decompilation, or disassembly of this software is permitted.

* You may not use or attempt to use this software in conjunction with any product that is offered by a third party as a replacement, substitute or alternative to a Marvell Product where a Marvell Product is defined as a proprietary wireless LAN embedded client solution of Marvell or a Marvell Affiliate.

DISCLAIMER. THIS SOFTWARE IS PROVIDED BY THE COPYRIGHT HOLDERS AND CONTRIBUTORS "AS IS" AND ANY EXPRESS OR IMPLIED WARRANTIES, INCLUDING, BUT NOT LIMITED TO, THE IMPLIED WARRANTIES OF MERCHANTABILITY AND FITNESS FOR A PARTICULAR PURPOSE ARE DISCLAIMED. IN NO EVENT SHALL THE COPYRIGHT OWNER OR CONTRIBUTORS BE LIABLE FOR ANY DIRECT, INDIRECT, INCIDENTAL, SPECIAL, EXEMPLARY, OR CONSEQUENTIAL DAMAGES (INCLUDING, BUT NOT LIMITED TO, PROCUREMENT OF SUBSTITUTE GOODS OR SERVICES; LOSS OF USE, DATA, OR PROFITS; OR BUSINESS INTERRUPTION) HOWEVER CAUSED AND ON ANY THEORY OF LIABILITY, WHETHER IN CONTRACT, STRICT LIABILITY, OR TORT (INCLUDING NEGLIGENCE OR OTHERWISE) ARISING IN ANY WAY OUT OF THE USE OF THIS SOFTWARE, EVEN IF ADVISED OF THE POSSIBILITY OF SUCH DAMAGE.

GNU

GNU GENERAL PUBLIC LICENSE TERMS AND CONDITIONS FOR COPYING, DISTRIBUTION AND MODIFICATION (Section 3.b.)

You may copy and distribute the Program (or a work based on it, under Section 2) in object code or executable form under the terms of Sections 1 and 2 above provided that you also do one of the following:

Accompany it with a written offer, valid for at least three years, to give any third party, for a charge no more than your cost of physically performing source distribution, a complete machine-readable copy of the corresponding source code, to be distributed under the terms of Sections 1 and 2 on a medium customarily used for software interchange.

The complete text for this license is available on the Control4 website at: <http://www.control4.com>.

Regulatory/Safety/Other Information

To review regulatory information for your particular Control4 products, see the information located on the Control4 website at: <http://www.control4.com/regulatory/>.

Patent Information

Protected under U.S. Patents 7,335,845, 7,106,261 and licensed under U.S. Patents 5,905,442 and 5,982,103

Warranty

Limited 2-year Warranty. Refer to <http://www.control4.com/warranty>.

About this Document

Part Number: 200-00288, Rev B, 6/11/2012



Regulatory Compliance & Safety Information for Control4 Model C4-TW7C0-XX.

Electrical Safety Advisory

Important Safety Information

Read the safety instructions before using this product.

1. Read these instructions.
2. Keep these instructions.
3. Heed all warnings.
4. Follow all instructions.
5. Do not use this apparatus near water.
6. Clean only with dry cloth.
7. Do not block any ventilation openings. Install in accordance with the manufacturer's instructions.
8. Do not install near any heat sources such as radiators, heat registers, stoves, or other apparatus (including amplifiers) that produce heat.
9. Do not defeat the safety purpose of the polarized or grounding-type plug. A polarized plug has two blades with one wider than the other. A grounding type plug has two blades and a third grounding prong. The wide blade or the third prong is provided for your safety. If the provided plug does not fit into your outlet, consult an electrician for replacement of the obsolete outlet.
10. Protect the power cord from being walked on or pinched particularly at plugs, convenience receptacles, and the point where they exit from the apparatus.
11. Only use attachments/accessories specified by the manufacturer.
12. Use only with the cart, stand, tripod, bracket, or table specified by the manufacturer, or sold with the apparatus. When a cart is used, use caution when moving the cart/apparatus combination to avoid injury from tip-over.
13. Unplug this apparatus during lightning storms or when unused for long periods of time. This equipment uses AC power which can be subjected to electrical surges, typically lightning transients which are very destructive to customer terminal equipment connected to AC power sources. The warranty for this equipment does not cover damage caused by electrical surge or lightning transients. To reduce the risk of this equipment becoming damaged it is suggested that the customer consider installing a surge arrestor.
14. Refer all servicing to qualified service personnel. Servicing is required when the apparatus has been damaged in any way, such as power-supply cord or plug is damaged, liquid has been spilled or objects have fallen into the apparatus, the apparatus has been exposed to rain or moisture, does not operate normally, or has been dropped.
15. Use the mains plug to disconnect the apparatus from the AC mains. The mains plug shall remain readily operable.
16. To completely disconnect unit power from the AC mains, disconnect the unit's power cord from the mains socket. To reconnect power, plug the unit's power cord into the mains socket following all safety instructions and guidelines.
17. **CAUTION:** As with all batteries, there is a risk of explosion or personal injury if the battery is replaced by an incorrect type. Dispose of used battery according to the instructions of the battery manufacturer and applicable environmental guidelines. Do not open, puncture or incinerate the battery, or expose it to conducting materials, moisture, liquid, fire or heat above 54° C or 130° F.

- Never push objects of any kind into this product through cabinet slots as they may touch dangerous voltage points or short out parts that could result in fire or electric shock.
- This product can interfere with electrical equipment such as tape recorders, TV sets, radios, computers and microwave ovens if placed in close proximity.



The lightning flash and arrow head within the triangle is a warning sign alerting you of dangerous voltage inside the product



Caution: To reduce the risk of electric shock, do not remove cover (or back). No user serviceable parts inside. Refer servicing to qualified service personnel.



The exclamation point within the triangle is a warning sign alerting you of important instructions accompanying the product.

See marking on bottom / back of product



Warning!: To reduce the risk of electrical shock, do not expose this apparatus to rain or moisture

AVERTISSEMENT! Pour réduire le risque de choc électrique, n'exposez pas cet appareil à la pluie ou à l'humidité.

WARNUNG! Um das Risiko des elektrischen Schlages zu verringern, setzen Sie diesen Apparat nicht Regen oder Feuchtigkeit aus.

Save these instructions

Compliance of this equipment is confirmed by the following label that is placed on the equipment:



USA & Canada Compliance

FCC Part 15, Subpart B / ICES-003 Unintentional Emissions Interference Statement

This equipment has been tested and found to comply with the limits for a Class B digital device, pursuant to Part 15 of the FCC rules and Industry Canada ICES-003. These limits are designed to provide reasonable protection against harmful interference when the equipment is operated in a residential installation. This equipment generates uses and can radiate radio frequency energy and, if not installed and used in accordance with the instructions, may cause harmful interference to radio communications. However, there is no guarantee that interference will not occur in a particular installation. If this equipment does cause harmful interference to radio or television reception, which can be determined by turning the equipment off and on, the user is encouraged to try to correct the interference by one or more of the following measures:



- Reorient or relocate the receiving antenna.
- Increase the separation between the equipment and receiver.
- Connect the equipment into an outlet on a circuit different from that to which the receiver is connected.
- Consult the dealer or an experienced radio/TV technician for help.

This device complies with part 15 of the FCC rules and Industry Canada ICES-003. Operation is subject to the following two conditions: (1) This device may not cause harmful interference, and (2) this device must accept any interference received, including interference that may cause undesired operation.

Le présent appareil est conforme aux CNR d'Industrie Canada applicables aux appareils radio exempts de licence. L'exploitation est autorisée aux deux conditions suivantes : (1) l'appareil ne doit pas produire de brouillage, et (2) l'utilisateur de l'appareil doit accepter tout brouillage radioélectrique subi, même si le brouillage est susceptible d'en compromettre le fonctionnement.

IMPORTANT! Any changes or modifications not expressly approved by the party responsible for compliance could void the user's authority to operate this equipment.

IMPORTANT! Tous les changements ou modifications pas expressément approuvés par la partie responsable de la conformité ont pu vider l'autorité de l'utilisateur pour actionner cet équipement.

Ferrite clamp installation. When installing a Control4® 7" In-Wall Touch Screen, also install the enclosed ferrite clamp as described in this document.

Ethernet cable. Install the ferrite clamp on the Ethernet cable no farther than 6 inches from the Ethernet jack.

Compliance of this equipment is confirmed by the following label that is placed on the equipment:



FCC Part 15, Subpart C / RSS-210 Intentional Emissions Interference Statement

Compliance of this equipment is confirmed by the following certification numbers that are placed on the equipment:

Notice: The term "FCC ID:" and "IC" before the certification number signifies that FCC and Industry Canada technical specifications were met.

FCC ID: R33C4TW7C0

IC: 7848A-C4TW7C0

This equipment must be installed by qualified professionals or contractors in accordance with FCC Part 15.203 & IC RSS-210, Antenna Requirements. Do not use any antenna other than the one provided with the unit.



RF Radiation Exposure Statement

This equipment complies with the FCC/IC radiation exposure limits set fourth for portable transmitting devices operation in an uncontrolled environment. End users must follow the specific operating instructions to satisfy RF exposure compliance.

- The equipment should only be used or installed at locations where there is normally at least a 20cm separation between the antenna and all persons.
- This transmitter must not be co-located or operation in conjunction with any other antenna or transmitter.
- Any changes or modifications not expressly approved by the party responsible for compliance could void the user's authority to operate this equipment.

European Compliance

Conformity of the equipment with the guidelines below is attested by the application of the CE mark.



CE Declaration of Conformity

Manufacturer's Name: CONTROL4 CORPORATION
Manufacturer's Address: 11734 S. ELECTION ROAD SUITE 200
SALT LAKE CITY
UT 84020 USA

EU Representative Name: CONTROL4 EMEA LIMITED
EU Representative Address: UNIT3, GREEN PARK BUSINESS CENTRE
SULTON-ON-THE FOREST
YORK YO61 IET, UNITED KINGDOM

Product Name(s): Touch Screen
Brand: Contol4
Model(s): C4-TW7C0-XX

Product Standard(s) to which Conformity of the Council Directive(s) is declared:

EMC - 2004/108/EC "Electromagnetic Compatibility (EMC) Directive":
(Emissions) EN 55022:2010, **(Immunity)** EN 55024:1998, EN 301 489-1:2008, EN 301 489-17:2009, EN 61000-3-2:2004 & EN 61000-3-3:2002

Safety – 206/95/EC "Low Voltage Directive (LVD)":
EN 60950-1:2006 (2nd Edition)

Telecom & Radio - 1999/5/EC Radio equipment and Telecommunications Terminal Equipment (R&TTE) Directive:
EN 300 328 V1.7.1 (2006-10)

RoHS - 2002/95/EC Restriction of the Use of certain Hazardous Substances in Electrical and Electronic Equipment (EEE) & WEEE - 2002/96/EC Waste of Electrical and Electronic Equipment (EEE).



We, the undersigned, hereby declare that the equipment specified above conforms to the above directives and standards. Date of Issue: June 5, 2012

Legal Representative

Signature

Roger Midgley
Sr. Regulatory Compliance Engineer



National Restrictions

This product may be used in all EU countries (and other countries following the EU directive 1999/5/EC) without any limitation except for the countries mentioned below:

Ce produit peut être utilisé dans tous les pays de l'UE (et dans tous les pays ayant transposés la directive 1999/5/CE) sans aucune limitation, excepté pour les pays mentionnés ci-dessous:

Questo prodotto è utilizzabile in tutte i paesi EU (ed in tutti gli altri paesi che seguono le direttive EU 1999/5/EC) senza nessuna limitazione, eccetto per i paesi menzionati di seguito:

Das Produkt kann in allen EU Staaten ohne Einschränkungen eingesetzt werden (sowie in anderen Staaten die der EU Direktive 1999/5/CE folgen) mit Ausnahme der folgenden aufgeführten Staaten:

France

In case the product is used outdoors, the output power is restricted in some parts of the band. See [Table 1](#) below or check <http://www.arcep.fr/> for more details.

Dans la cas d'une utilisation en extérieur, la puissance de sortie est limitée pour certaines parties de la bande. Voir la table ci-dessous ou visitez <http://www.arcep.fr/> pour de plus amples details

Table 1 Applicable Power Levels in France		
Location	Frequency Range (MHz)	Power (EIRP)
Indoor (No restrictions)	2400-2483.5	100 mW (20 dBm)
Outdoor	2400-2454	100 mW (20 dBm)
	2454-2483.5	10 mW (10 dBm)

Recycling

Control4 understands that a commitment to the environment is essential for a health life and sustainable growth for future generations. We are committed to supporting the environmental standards, laws, and directives that have been put in place by various communities and countries that deal with concerns for the environment. This commitment is represented by combining technological innovation with sound environmental business decisions.



WEEE Compliance

Control4 is committed to meeting all requirements of the Waste Electrical and Electronic Equipment (WEEE) directive (2002/96/EC). The WEEE directive requires the manufacturers of electrical and electronic equipment who sell in EU countries: (1) label their equipment to notify customers that it needs to be recycled, and (2) provide a way for their products to be appropriately disposed of or recycled at the end of their product lifespan. For collection or recycling of Control4 products, please contact your local Control4 representative or dealer.



Australia / New Zealand Compliance

Compliance of this equipment is confirmed by the following label that is placed on the equipment:



About this Document

Copyright © 2012 Control4 Corporation. All rights reserved. Control4 and the Control4 logo are registered trademarks or trademarks of Control4 Corporation in the United States and/or other countries.

Part Number 200-00292 Rev A, 6/5/2012