

Dell™ 5100MP Projector



Owner's Manual



Dell™ 5100MP Projector

Owner's Manual

Notes, Notices, and Cautions



NOTE: A NOTE indicates important information that helps you make better use of your projector.



NOTICE: A NOTICE indicates either potential damage to hardware or loss of data and tells you how to avoid the problem.



CAUTION: A CAUTION indicates a potential for property damage, personal injury, or death.

Information in this document is subject to change without notice.

© 2005 Dell Inc. All rights reserved.

Reproduction in any manner whatsoever without the written permission of Dell Inc. is strictly forbidden.

Trademarks used in this text: *Dell*, the *DELL* logo, *Dimension*, *OptiPlex*, *Dell Precision*, *Latitude*, *Inspiron*, *DellNet*, *PowerApp*, *PowerEdge*, *PowerConnect*, and *PowerVault* are trademarks of Dell Inc.; *DLP* and *Texas Instruments* are trademarks of Texas Instruments Corporation; *Microsoft* and *Windows* are registered trademarks of Microsoft Corporation; *Macintosh* is a registered trademark of Apple Computer, Inc.

Other trademarks and trade names may be used in this document to refer to either the entities claiming the marks and names or their products. Dell Inc. disclaims any proprietary interest in trademarks and trade names other than its own.

Restrictions and Disclaimers

The information contained in this document, including all instructions, cautions, and regulatory approvals and certifications, is based upon statements provided to Dell by the manufacturer and has not been independently verified or tested by Dell. Dell disclaims all liability in connection with any deficiencies in such information.

All statements or claims regarding the properties, capabilities, speeds, or qualifications of the part referenced in this document are made by the manufacturer and not by Dell. Dell specifically disclaims any knowledge of the accuracy, completeness, or substantiation for any such statements.

Contents

1	Your Dell Projector	
	About Your Projector	8
2	Connecting Your Projector	
	Connecting to a Computer	10
	Connecting a Computer with an M1 to D-sub/USB Cable	10
	Connecting a Computer with a D-sub to D-sub Cable	11
	Connecting to a DVD Player	12
	Connecting a DVD Player with an M1 to HDTV Cable	12
	Connecting a DVD Player with a D-sub to YPbPr Cable	12
	Connecting a DVD Player with a RCA to RCA Cable	13
	Connecting a DVD Player with an S-video Cable . .	13
	Connecting a DVD Player with a Composite Cable .	14
	Connecting a DVD Player with a BNC to VGA cable	14
	Professional Installation Options: Installation for Driving Automatic Screen	15
	Installation for wired RS232 remote control: Connection with PC	16
	Connection with Commercial RS232 Control Box: .	17

3 Using Your Projector

Turning Your Projector On	19
Turning Your Projector Off	19
Adjusting the Projected Image	20
Raising the Projector Height	20
Lowering the Projector Height	20
Adjusting the Projector Zoom and Focus	21
Adjusting Projection Image Size	22
Using the Control Panel	23
Using the Remote Control	25
Using the On-Screen Display	28
Image Settings	28
Audio Menu	30
Management Menu	31
Language Menu	33
PIP Setting Menu	33
Network Settings Menu	34
Factory Reset Menu	35
Computer Source Menu	35
Video Source Menu	35
RF Learning Connections	36
To manage the projector from Web Management	39

4 Troubleshooting Your Projector

Self-diagnostic for Video	48
Changing the Lamp	48

5 Specifications

6 Contacting Dell

7 Appendix: Regulatory Notices

FCC Notices (U.S. Only) 85

NOM Information (Mexico Only) 86

8 Glossary

9 Index

Your Dell Projector

Your projector comes with all the items shown below. Ensure that you have all the items, and contact Dell if anything is missing.

Package Contents

1.8m power cord (3.0m in Americas)

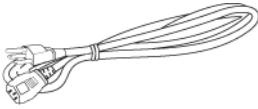

1.8m M1 to D-sub/USB cable

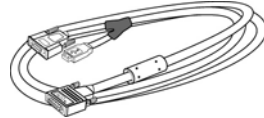

2.0m S-video cable



1.8m Composite Video cable



1.8m RCA to Audio cable



1.8m mini pin to mini pin cable

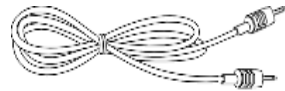

1.8m M1-A to HDTV cable

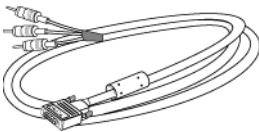

Remote control



Package Contents *(continued)*

Documentation



Lens cap



Batteries (2)

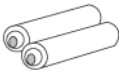

About Your Projector

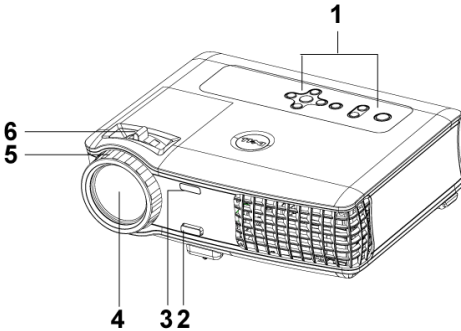

1	Control panel
2	Elevator button
3	Remote control receiver
4	Lens
5	Focus ring
6	Zoom tab

2

Connecting Your Projector

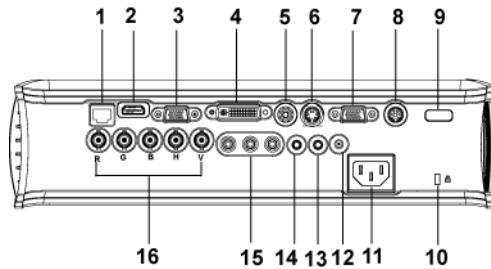

1	RJ45 network connector
2	HDMI connector
3	VGA input connector
4	MI signal in connector
5	Video input connector
6	S-video input connector
7	VGA output connector
8	RS232 connector
9	IR receiver
10	Kensington lock hole
11	Power cord connector
12	12 Volt DC relay output
13	Audio output connector
14	Audio input connector
15	Component video input connector
16	BNC connector

Connecting to a Computer

Connecting a Computer with an M1 to D-sub/USB Cable

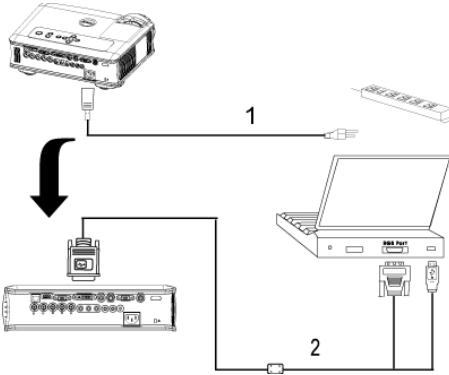

1	Power cord
2	M1A to D-sub/USB cable



NOTE: The USB cable can not be connected if the USB Dongle is used, for the USB dongle connection refer to page 37.

Connecting a Computer with a D-sub to D-sub Cable

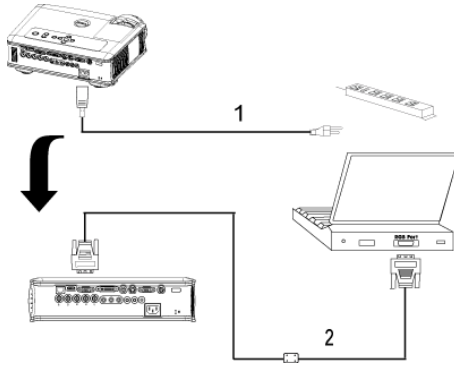

1	Power cord
2	D-sub to D-sub cable



NOTE: The USB cable can not be connected if the USB Dongle is used, for the USB dongle connection refer to page 37.

Connecting to a DVD Player

Connecting a DVD Player with an M1 to HDTV Cable

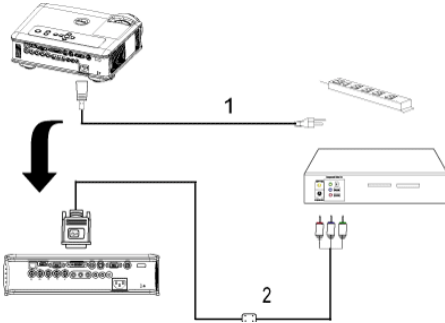

1	Power cord
2	M1 to HDTV cable

Connecting a DVD Player with a D-sub to YPbPr Cable

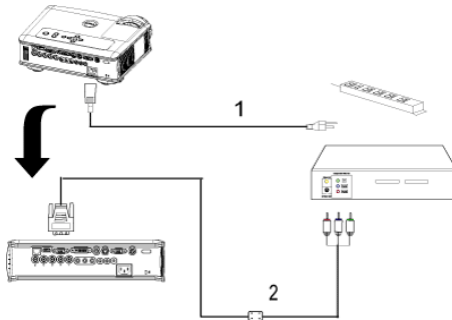

1	Power cable
2	D-sub to YPbPr cable



NOTE: The D-sub to YPbPr cable is not provided by Dell. Consult a professional installer for the cable.

Connecting a DVD Player with a RCA to RCA Cable

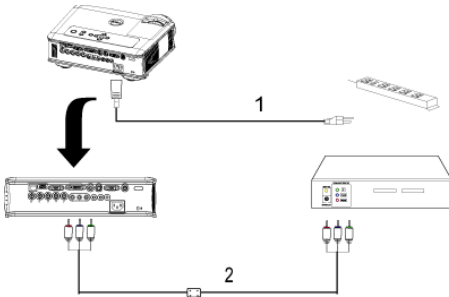

1	Power cable
2	RCA to RCA component cable

 **NOTE:** The RCA to RCA cable is not provided by Dell. Consult a professional installer for the cable.

Connecting a DVD Player with an S-video Cable

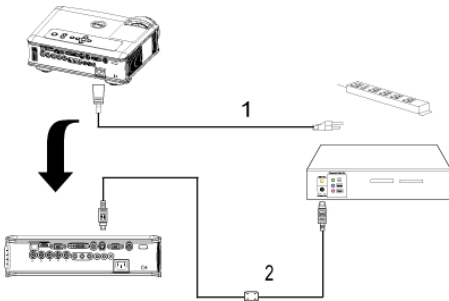

1	Power cable
2	S-video cable

Connecting a DVD Player with a Composite Cable

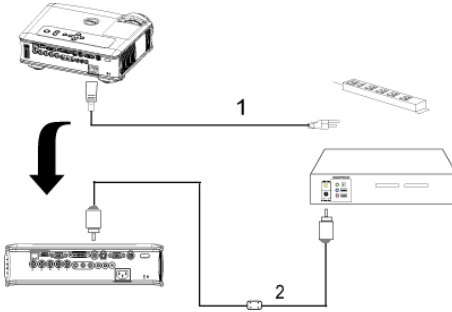

1	Power cable
2	Composite video cable

Connecting a DVD Player with a BNC to VGA cable

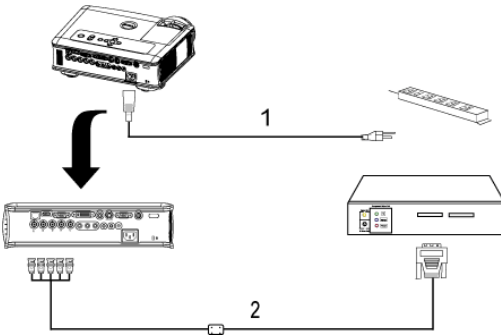

1	Power cable
2	BNC to VGA cable



NOTE: The BNC to VGA cable is not provided by Dell. Consult a professional installer for the cable.

Professional Installation Options: Installation for Driving Automatic Screen

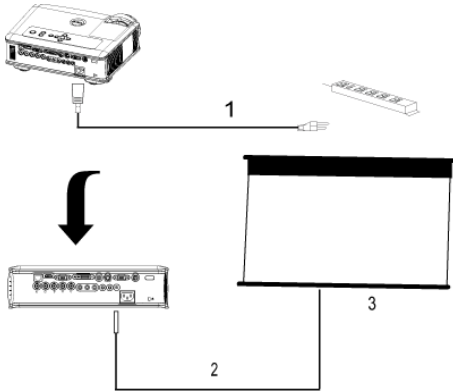

1	Power cable
2	12V DC power cord
3	Automatic screen

Installation for wired RS232 remote control: Connection with PC

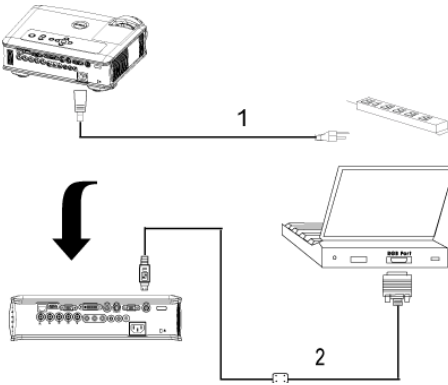

1	Power cable
2	RS232 cable



NOTE: The RS232 cable is not provided by Dell. Consult a professional installer for the cable.

Connection with Commercial RS232 Control Box:

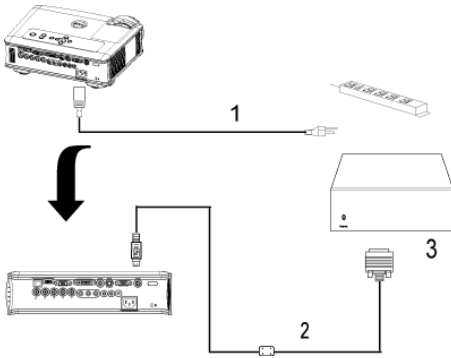

1	Power cable
2	RS232 cable
3	Commercial RS232 control box



NOTE: The RS232 cable is not provided by Dell. Consult a professional installer for the cable.

Using Your Projector

Turning Your Projector On

 **NOTE:** Turn on the projector before you turn on the source. The power button light blinks blue until pressed.

- 1 Remove the lens cap.
- 2 Connect the power cord and appropriate signal cables. For information about connecting the projector, see page 9.
- 3 Press the power button (see page 23 to locate the power button). The Dell logo displays for 30 seconds.
- 4 Turn on your source (computer, DVD player, etc.). The projector automatically detects your source.

If the "Searching for signal..." message appears on the screen, ensure that the appropriate cable(s) are securely connected.

If you have multiple sources connected to the projector, press the **Source** button on the remote control or control panel to select the desired source.

Turning Your Projector Off

 **NOTICE:** Do not unplug the projector before properly shutting down as explained in the following procedure.

- 1 Press the power button.
- 2 Press the power button again. The cooling fans continue to operate for 90 seconds and then go to standby mode.
- 3 Disconnect the power cord from the electrical outlet.

 **NOTE:** If you press the power button while the projector is running, the "Power Off the Lamp?" message appears on the screen. To clear the message, press any button on the control panel or ignore the message; the message disappears after 5 seconds.

Adjusting the Projected Image

Raising the Projector Height

- 1 Press the elevator button.
- 2 Raise the projector to the desired display angle, and then release the button to lock the elevator foot into position.
- 3 Use the tilt adjustment wheel to fine-tune the display angle.

Lowering the Projector Height

- 1 Press the elevator button.
- 2 Lower the projector, and then release the button to lock the elevator foot into position.

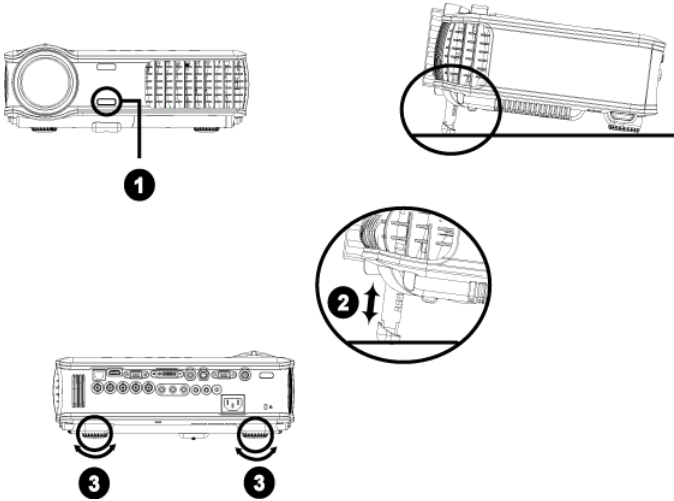

1	Elevator button
2	Elevator foot
3	Tilt adjustment wheel

Adjusting the Projector Zoom and Focus



CAUTION: To avoid damaging the projector, ensure that the zoom lens and elevator foot are fully retracted before moving the projector or placing the projector in its carrying case.

- 1 Rotate the zoom tab to zoom in and out.
- 2 Rotate the focus ring until the image is clear. The projector focuses at distances from 4.9 ft to 39.4ft (1.5 m to 12 m).

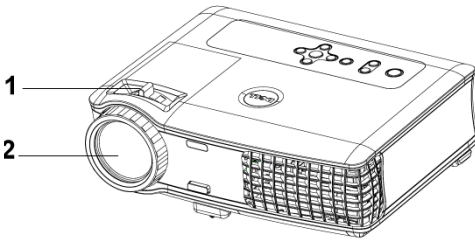

1	Zoom tab
2	Focus ring

Adjusting Projection Image Size

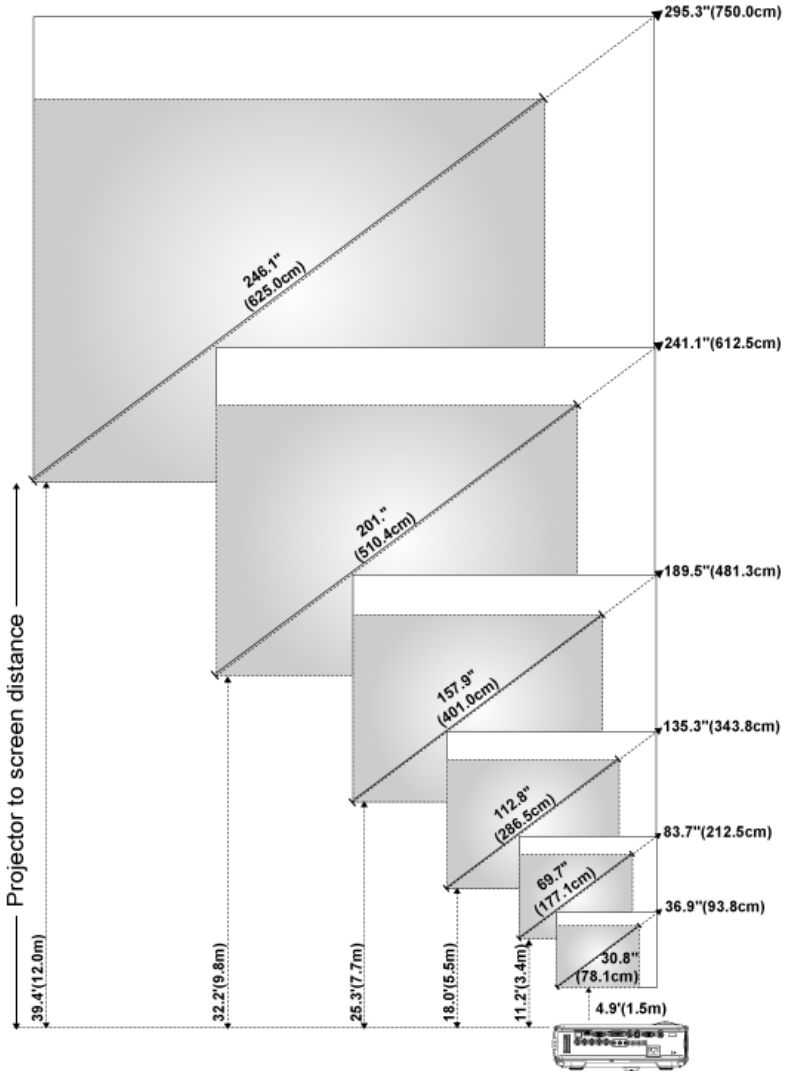

Screen (Diagonal)	Max.	36.9" (93.8cm)	83.7" (212.5cm)	135.3" (343.8cm)	189.5" (481.3cm)	241.1" (612.5cm)	295.3" (750.0cm)
	Min.	30.8" (78.1cm)	69.7" (177.1cm)	112.8" (286.5cm)	157.9" (401.0cm)	201.0" (510.4cm)	246.1" (625.0cm)
Screen Size	Max. (WxH)	29.5" X 22.1"	66.9" X 50.2"	108.3" X 81.2"	151.6" X 113.7"	192.9" X 144.7"	236.2" X 177.2"
		(75.0cm X 56.3cm)	(170.0cm X 127.5cm)	(275.0cm X 206.3cm)	(385.0cm X 288.8cm)	(490.0cm X 367.5cm)	(600.0cm X 450.0cm)
	Min. (WxH)	24.6" X 18.5"	55.8" X 41.8"	90.2" X 67.7"	126.3" X 94.7"	160.8" X 120.6"	196.9" X 147.6"
		(62.5cm X 46.9cm)	(141.7cm X 106.3cm)	(229.2cm X 171.9cm)	(320.8cm X 240.6cm)	(408.3cm X 306.3cm)	(500.0cm X 375.0cm)
Distance		4.9' (1.5m)	11.2' (3.4m)	18.0' (5.5m)	25.3' (7.7m)	32.2' (9.8m)	39.4' (12.0m)
* This graph is for user reference only.							

Using the Control Panel

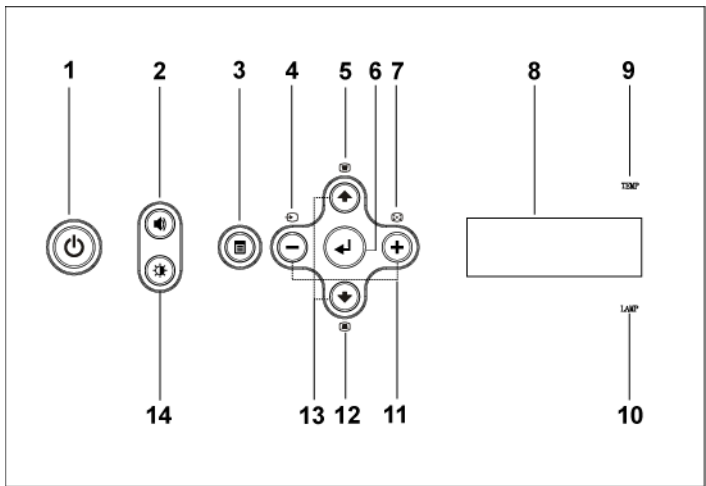

1	Power	Turn the projector on and off. For more information, see page 19 and page 19.
2	Volume Control	Press to control the volume, then press - or + buttons to decrease or increase the volume.
3	Menu	Press to activate the OSD. Use the directional keys and Menu button to navigate through the OSD.

4	Source	Press to toggle through S-video, Composite Video, M1-D, D-sub, BNC, Component, HDMI, SCART and M1 sources when multiple sources are connected to the projector.
5	Keystone adjustment	Press to adjust image distortion caused by tilting the projector. (± 20 degrees)
6	Enter	Press to confirm the selection item.
7	Auto adjust	Press to synchronize the projector to the input source. Auto adjust does not operate if the on-screen display (OSD) is displayed.
8	LCD status display	LCD display is for real time projector status.
9	TEMP warning light	<ul style="list-style-type: none"> • If the TEMP light is solid orange, the projector has overheated. The display automatically shuts down. Turn the display on again after the projector cools down. If the problem persists, contact Dell. • If the TEMP light is blinking orange, a projector fan has failed and the projector automatically shuts down. If the problem persists, contact Dell.
10	LAMP warning light	If the LAMP light is solid orange, replace the lamp.
11	⊖ and ⊕ buttons	Press to adjust the OSD setting.
12	Keystone adjustment	Press to adjust image distortion caused by tilting the projector. (± 20 degrees)
13	Up ⬆ and ⬇ Down	Press to select the OSD items.
14	Brightness and contrast control	Press to control brightness and contrast, press ⬆ or ⬇ to adjust brightness or contrast, then press ⊖ and ⊕ buttons to adjust the value.

Using the Remote Control

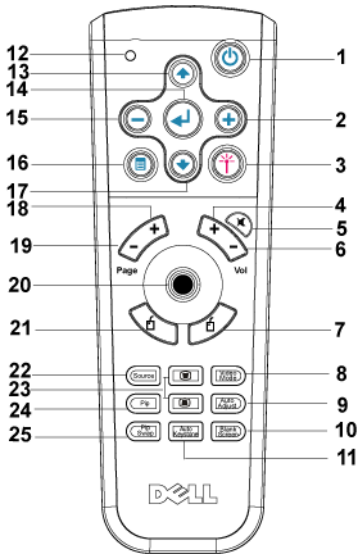

1	Power	Turn the projector on and off. For more information, see page 19 and page 19.
2	+	Press to adjust the OSD setting.
3	Laser	Aim the remote control at the screen, press and hold the laser button to activate the laser light.
4	Volume +	Press to increase the volume.
5	Mute	Press to mute or un-mute the projector speaker.
6	Volume -	Press to decrease the volume.
7	Right click	Mouse right click.

8	Video mode	The Dell 5100MP Micro-projector has preset configurations that are optimized for displaying data (PC Graphics) or video (movies, games, etc.). Press Video Mode button to toggle between PC mode , Movie mode , Game Mode , sRGB , or User mode (for user to setup and save preferred settings). Pressing the Video Mode button once will show the current display mode. Pressing the Video Mode button again will switch between modes.
9	Auto Adjust	Press to synchronize the projector to the input source. Auto Adjust does not operate if the OSD (On-Screen Display) is displayed.
10	Blank screen	Press to hide the image, press again to resume display of the image.
11	Auto keystone	Press to enable the auto correction for image distortion due to tilting the projector.
12	LED light	LED indicator.
13	Up button	Press to select OSD items.
14	Enter button	Press to confirm the selection.
15	⊖	Press to adjust the OSD setting.
16	Menu	Press to activate the OSD.
17	Down button	Press to select OSD items.
18	Page ⊕	Press to move to previous page.
19	Page ⊖	Press to move to next page.
20	PC/Mouse control	The PC/Mouse control can be used to control mouse movement. The mouse function is enabled using the M1 cable to connect your computer and the projector.
21	Left click	Mouse left click
22	Source	Press to switch between Analog RGB, Digital RGB, Composite, Component-i, S-video, and Analog YPbPr sources.
23	Keystone correction	Press to correct the image distortion.
24	PIP	Press the PIP button to turn on/off the PIP screen.

25 PIP Swap

Press the PIP Swap button to swap between the foreground and background.

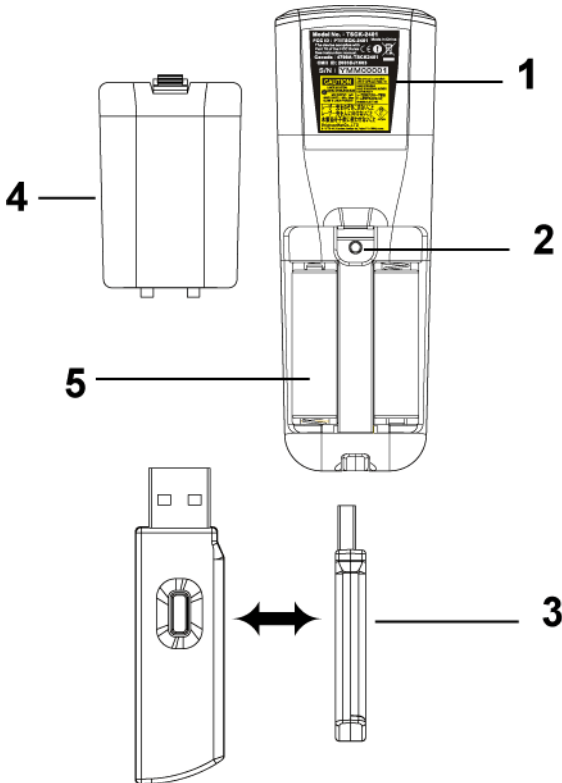

1 Laser Warning

The remote control is equipped with a Class II laser that emits laser radiation. To reduce the risk of injury, do not look directly into the laser light, and do not point the laser light into anyone's eyes.

2 Program button

Initiate the **Learning Mode** on the remote for switching the RF transmission channel by pressing **Prgm** button.

3	Wireless USB mouse dongle	The wireless USB device for controlling PC or Notebook mouse through the remote control.
4	Remote cover	The back cover of the remote control.
5	Battery chamber	The chamber of the battery.

Using the On-Screen Display

The projector has a multi-language On-Screen Display (OSD) that can be displayed with or without an input source present.

In the Main Menu, press **⬆** or **⬇** to navigate through the tabs. Press **Enter** button on the control panel or the remote control to select a submenu.

In the submenu, press **⬆** or **⬇** to make a selection. When an item is selected, the color changes to dark gray. Use **⬅** or **➕** on the control panel or the remote control to make adjustments to a setting.

To back to the previous OSD, go to **Back** tab and press **Enter** button on the control panel or the remote control.

To exit the OSD, go to **Exit** tab and press **Enter** button on the control panel or the remote control.

Image Settings



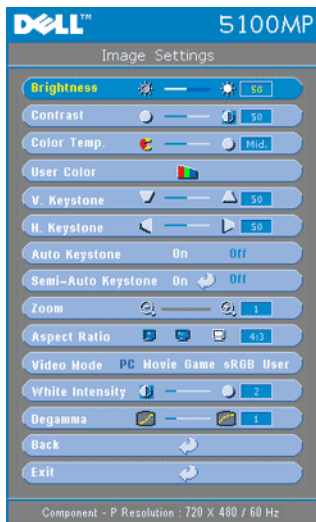

BRIGHTNESS—Use \ominus and \oplus to adjust the brightness of the image.

CONTRAST—Use \ominus and \oplus to control the degree of difference between the brightest and darkest parts of the picture. Adjusting the contrast changes the amount of black and white in the image.

COLOR TEMP.—Adjust the color temperature. The higher the temperature, the screen appears more blue; the lower the temperature, the screen appears more red. User mode activates the values in the "color setting" menu.

USER COLOR—This mode allows manual adjustment of red, green, and blue color settings. Modifying these values will automatically change the color temperature

to "user". Press the **User Color**, then go into the **Color Setting** Menu.

V. KEYSTONE—Adjust image distortion caused by tilting the projector.

H. KEYSTONE—Adjust image distortion caused by horizontal shifting of the projector orientation.

AUTO KEYSTONE—Select **On** to enable the auto correction for vertical image distortion due to tilting the projector. Select **Off** to disable the auto correction.

SEMI-AUTO KEYSTONE—Select **On** and press **Enter** to activate the Semi-Auto keystone correction for image distortion. A specific image pattern will be present on the screen once it's been activated and then complete the settings by following below instructions.

- Adjust the projected image display to appropriate location on the screen.
- Use up, down, left or right button to choose one corner and press **Enter** key to enter keystone correction mode.
- Use up, down, left or right button to move the angle and press **Enter** to confirm.

Zoom—Press \oplus to \ominus digitally magnify an image to 10 times on the projection screen and press \ominus to reduce the zoomed image.

ASPECT RATIO—Select an aspect ratio to adjust how the image appears.

- **1:1** — The input source displays without scaling.

Use 1:1 aspect ratio if you are using one of the following:

- VGA cable and the computer has a resolution less than SXGA+ (1400 x 1050)

- Component cable (576p/480i/480p)
- S-Video cable
- Composite cable
- **16:9** — The input source scales to fit the width of the screen.
- **4:3** — The input source scales to fit the screen
Use 16:9 or 4:3 if you are using one of the following:
 - Computer resolution greater than SXGA+
 - Component cable (1080i or 720p)

VIDEO MODE—Select a mode to optimize the display image based on how the projector is being used: **Movie**, **Game**, **PC**, **sRGB** (provides more accurate color representation), and **User** (set your preferred settings). If you adjust the settings for **White Intensity** or **Degamma**, the projector automatically switches to **User**.

WHITE INTENSITY—Setting 0 to maximize the color reproduction and 10 to maximize the brightness.

DEGAMMA—Adjust between 1 and 4 to change the color performance of the display. The default setting is 3.

Audio Menu



VOLUME—Press \ominus to decrease the volume and \oplus to increase the volume.

TREBLE—Control the higher frequencies of your audio source. Press \ominus to decrease the treble and press \oplus to increase the treble.

BASS—Control the lower frequencies of your audio source. Press \ominus to decrease the bass and press \oplus to increase the bass.

MUTE—Allow to mute the volume.

AUDIO SOURCE—Select **HDMI** to have the HDMI output source, and select **Audio** to have the audio output source.

Management Menu

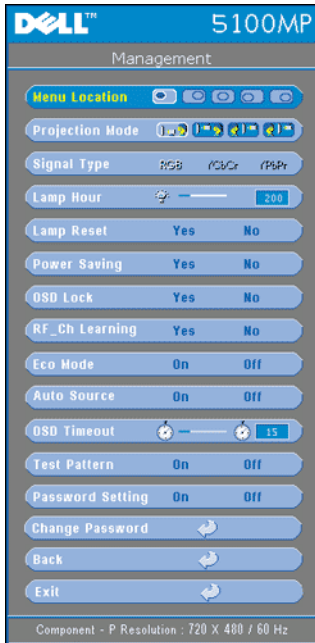

select **Yes** to reset the lamp timer.

POWER SAVING—Select **Yes** to set the power saving delay period. The delay period is the amount of time you want the projector to wait without signal input. After that set time, the projector enters power saving mode and turns off the lamp. The projector turns back on when it detects an input signal or you press the power button. After two hours, the projector turns off and you need to press the power button to turn the projector on.

AUTO SOURCE—Select **On** (the default) to autodetect the available input signals. When the projector is on and you press **SOURCE**, it automatically finds the next available input signal. Select **Off** to lock the current input signal. When **Off** is selected and you press **SOURCE**, you select which input signal you want to use.

MENU LOCATION—Select the location of the OSD on the screen.

PROJECTION MODE—Select how the image appears:

- Front Projection-Desktop (the default).
- Rear Projection-Desktop-- The projector reverses the image so you can project from behind a translucent screen.
- Front Projection-Ceiling Mount-- The projector turns the image upside down for ceiling-mounted projection.
- Rear Projection-Ceiling Mount-- The projector reverses and turns the image upside down. You can project from behind a translucent screen with a ceiling-mounted projection.

SIGNAL TYPE—Show signal type RGB, YCbCr, YPbPr.

LAMP HOUR—Display the operating hours since the lamp timer reset.

LAMP RESET—After you install a new lamp,

OSD Lock—Select **Yes** to enable **OSD Lock** for hiding the OSD menu. (Or pressing the Menu button on control for 15 seconds), and select **No** to disable the **OSD Lock** for hiding the OSD menu. (Or pressing the Menu button on control for 15 seconds again).

RF_CH LEARNING—Refer to page 36.

Eco MODE—Select **On** to use the projector at a lower power level (250 Watts), which may provide longer lamp life, quieter operating and dimmer luminance output on the screen. Select **Off** to operate at normal power level (300 Watts).

AUTO SOURCE—Select **On** (the default) to autodetect the available input signals. When the projector is on and you press **SOURCE**, it automatically finds the next available input signal. Select **Off** to lock the current input signal. When **Off** is selected and you press **SOURCE**, you select which input signal you want to use.

OSD TIMEOUT—Adjust the time delay of the **OSD Timeout**. The Default setting is 30 seconds.

TEST PATTERN—Select **On** to come up the built-in **Test Pattern** for self-testing on focus and resolution





PASSWORD SETTING—Select **On** to set one password for individual. Select **Off** to disable the password function.

CHANGE PASSWORD—Press to change the password to your preference..

Language Menu



Press  or  to select the preferred language for the OSD.

PIP Setting Menu

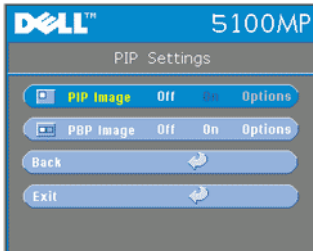

 NOTE 1: PIP Image is enabled only when both the following types of signals are connected to the projector.

Type 1: S-Video, Composite Video, MI-D, and

Type 2: D-sub, BNC, Component, HDMI, SCART, MI signals.

 NOTE 2: When swapping the foreground and background displays, the smallest screen size of foreground display will vary depending on different combinations of signal sources for PIP.

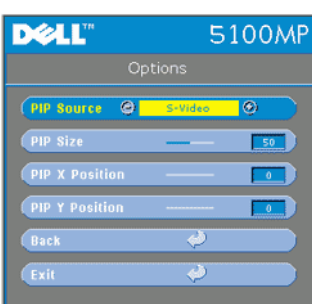

PIP IMAGE—Select **On** to enter **Options** to select following settings. Select **Off** to disable the picture-in-picture display function.

PIP SOURCE—Use **PIP Source** to step through the display source one by one for the foreground display. The possible PIP source is available in the OSD selection depending on the current primary input source. The possible combination of the sources refer to page 54.

PIP SIZE—Adjust the image size of the foreground display.

PIP X POSITION—Horizontally adjust the image position of the PIP display.

PIP Y POSITION—Vertically adjust the image position of the PIP display.

PBP IMAGE—Select **On** to enable the picture-by-picture display. Select **Off** to disable the picture-by-picture function.

Network Settings Menu



DHCP—Select **On** to assign an IP address to the projector from a **DHCP** server automatically. Select **Off** to assign an IP address manually.

IP ADDRESS—Press **Enter** to set up an IP address. Press left or right button to select the number position, up or down button to change the number.

SUBNET MASK—Press **Enter** to set up a subnet mask number. Press left or right button to select the number position, up or down button to change the number.

GATEWAY—Select to set the default gateway of the network connected to the projector. Press left or right button to select the number

position, up or down button to change the number.

DNS—Type in the IP address of DNS server on the network connected to the projector. 12 numeric characters are used.

APPLY CHANGE—Press to confirm the settings.

RESET NETWORK SETTING—Press to the default setting.

Factory Reset Menu

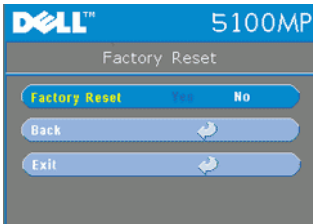

FACTORY RESET—Select **Yes** to reset the projector to its factory default settings. Reset items include both computer image and video image settings

Computer Source Menu

 **NOTE:** This menu is only available connected to a computer.

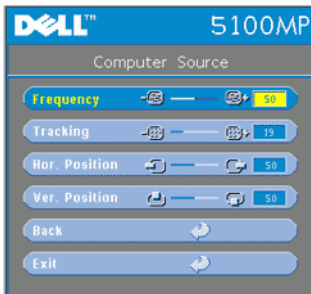

FREQUENCY—Change the display data clock frequency to match the frequency of your computer graphics card. If you see a vertical flickering bar, use **Frequency** control to minimize the bars. This is a coarse adjustment.

TRACKING—Synchronize the phase of the display signal with the graphic card. If you experience an unstable or flickering image, use the **Tracking** to correct it. This is a fine adjustment.

 **NOTE:** Adjust the **Frequency** first and then the **Tracking**.

HOR. POSITION—Press \ominus to adjust the horizontal position of the image to the left and \oplus to adjust the horizontal position of the image to the right.

VER. POSITION—Press \ominus to adjust the vertical position of the image down and \oplus to adjust the vertical position of the image up.

Video Source Menu

 **NOTE:** This menu is only available with S-video, Video (composite) signal connected.

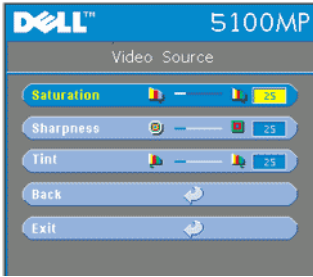

SATURATION—Adjust a video source from black and white to fully saturated color. Press \ominus to decrease the amount of color in the image and \oplus to increase the amount of color in the image.

SHARPNESS—Press \ominus to decrease the sharpness and \oplus to increase the sharpness.

TINT—Press \ominus to increase the amount of green in the image and \oplus to increase the amount of red in the image.

RF Learning Connections

Auto Learning to Change RF Channel Between Remote Controller and Projector

- Power on the projector.
- Press the "Menu" button on control panel, then enter to "Management-->RF_Ch Learning" menu.

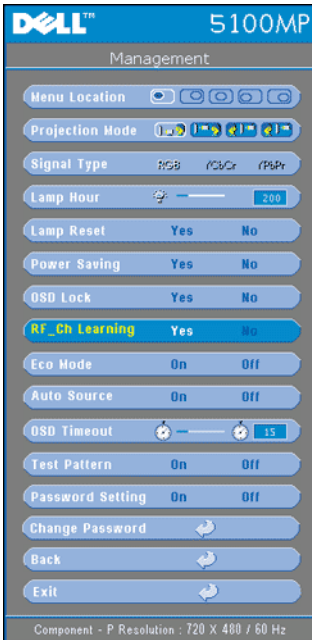

- Select **Yes** with the control buttons to enter the **Learning Standby** mode. The projector will switch to standby mode for **RF Learning** and display the **RF Learning** menu.
- Open the battery cover on the remote control and press the **Prgm** button to initiate the **RF Learning** process for the remote control and projector.

Back to Factory Default for the RF Channel

- Select **Yes** on **RF Learning Setting** menu and then enter the **RF Reset to Default** menu. Select **Reset to Default Channel**, the projector will back to the factory default channel.
- Press the **Prgm** button on the remote control for 5 seconds to reset the transmitter to the factory default channel.

- The successful reset back to the default channel on both ends can be confirmed when the remote control transmitter controls the projector.

Auto Learning to Change RF Channel Between Remote Controller and USB Wireless Dongle

Step 1	Open the cover of the remote control.
Step 2	Push the dongle.
Step 3	Take out the dongle from the remote control.
Step 4	Plug the dongle in the USB port on your desktop or notebook computer, the dongle will show red .
Step 5	Press the LED button on the dongle and it will flash "red" for 13 seconds.
Step 6	<p>Press the Prgm button in the rear of the remote control, within 13 seconds to initiate the RF Learning process.</p> <ul style="list-style-type: none"> • If the processes are successful, the dongle LED will remain "red" and stop flashing. • Checking the mouse function are enable by using the remote control, if it has done, the dongle LED will show a "green" signal.
Step 7	Using the remote control to manage your desktop or notebook computer.

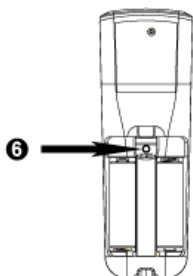
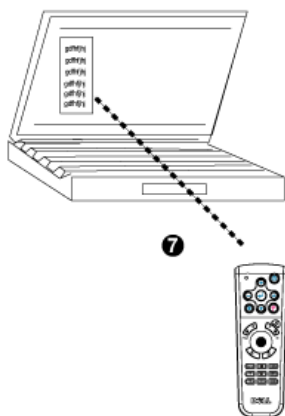
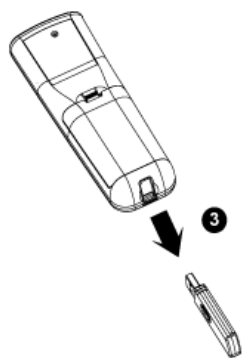
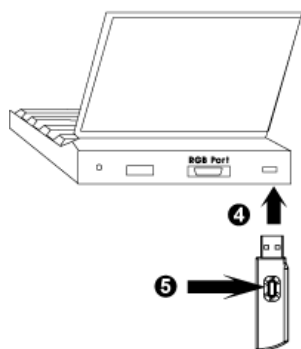
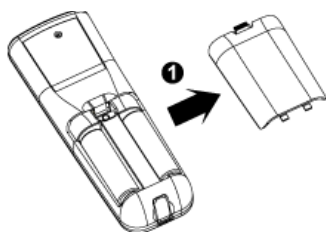
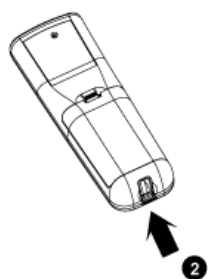

To manage the projector from Web Management

Configuring the Network Setting

If the projector is connected to a network, you can access the projector using a web browser by configuring the network setting (TCP/IP). When using the network function, the IP address should be unique. There are two ways for configuring the network setting.

- 1** Using the IP Address function on **Network Setting** menu; See OSD section page 34, or,
- 2** Use the AP software to set up network setting for the projector.

Accessing the Web Management

Use Internet Explorer 5.0 and above or Netscape Navigator 7.0 and above and enter the IP address. You can now access **Web Management** and manage the projector from a remote location.

Managing Properties

Home

The screenshot shows the Dell 5100MP Web Management interface. The top navigation bar is blue with the Dell logo and the text "5100MP Web Management". On the left, there is a sidebar with five menu items, each with a play button icon: "Home", "Network Setting", "Projector Status and Control", "E-mail Alert", and "Password Setting". The main content area is titled "Home" and contains a welcome message: "Welcome to DELL 5100MP Web Management." Below this is a section titled "Projector Information" with the following details:

Group Name:	5100MP
Projector Name:	D12345
Location:	
Contact:	
Status:	Standby
Lamp Hours:	0 hr
Firmware Version:	A 1.0
IP Address:	10.0.50.100
MAC Address:	00:12:3F:6E:A8:B8
Admin Password:	Not Set!

Below the projector information is a "Language" section with a dropdown menu set to "English" and a "Submit" button.

Displays Group name, Projector name, Location, Contact, Lamp hours, Firmware version, IP address, MAC address and Admin password information.

Network Setting

See OSD section on page 34.

DELL™ 5100MP Web Management

[Home](#)

[Network Setting](#)

[Projector Status and Control](#)

[E-mail Alert](#)

[Password Setting](#)

Network Setting

Group Name:

Projector Name:

Location:

Contact:

DHCP Manual

IP Address:

Subnet Mask:

Gateway:

DNS Server:

- Set up the Group Name, Projector Name, Location and Contact information in this tab, press **Submit** to confirm the settings.
- Choose **DHCP** to assign an IP address to the projector from a **DHCP** server automatically, or **Manual** to assign an IP address manually.

Projector Status and Control

The function is same as On Screen Display.

DELL™ 5100MP Web Management

- [▶ Home](#)
- [▶ Network Setting](#)
- [▶ **Projector Status and Control**](#)
- [▶ Email Alert](#)
- [▶ Password Setting](#)

Projector Status and Control

Projector Status

Projector Status

Power Saving

Lamp Hours

Error Status

Image Control

Operation Mode Full Power ECO Mode

Projection Mode

Source Select

Video Mode

Freeze On Off

Hide On Off

Aspect ratio 1:1 4:3 16:9

Brightness (0~100)

Contrast (0~100)

Audio Control

Volume (0~63)

Manage the projector status and image control and audio control using Projector Status and Control.

E-mail Alert

The screenshot shows the Dell 5100MP Web Server interface. The top navigation bar is blue with the Dell logo and the text "5100MP Web Server". On the left, there is a sidebar with navigation links: Home, Network Setting, Projector Status and Control, E-mail Alert (which is highlighted), and Password Setting. The main content area is titled "E-mail Alert" and contains the following sections:

- E-mail Alert:** A radio button is selected for "Enable", and "Disable" is unselected.
- TO:** Input field containing "admin@dell.com".
- CC:** Input field containing "mis@dell.com".
- From:** Input field containing "admin@dell.com".
- Subject:** Input field containing "5100MP_Sample Status".
- SMTP Setting:**
 - Out going SMTP server: Input field containing "192.168.2.100".
 - User name: Input field containing "admin".
 - Password: Input field containing "ADMIN".
- Alert condition:** A list of conditions with checkboxes:
 - Burned out bulb
 - Lamp over-heating
 - Lamp hours running out
 - Fan error
 - Projector over-heating
- Buttons: "E-mail Alert Test" and "Submit".

Setting the e-mail address, owner and subject in this tab, select the **Alert Condition**, once the alert condition coming up, the **E-mail Alert** will inform the preseted administer automatically.

Password Setting

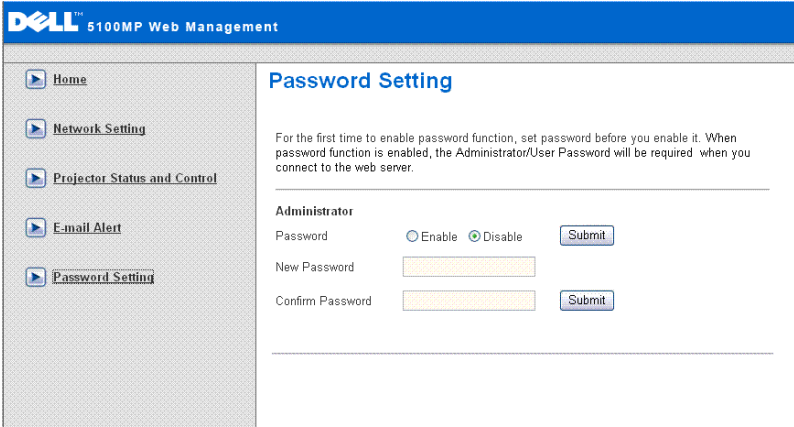







The screenshot shows the Dell 5100MP Web Management interface. The top navigation bar is blue with the Dell logo and the text "5100MP Web Management". On the left, there is a sidebar with a list of menu items: Home, Network Setting, Projector Status and Control, E-mail Alert, and Password Setting (which is highlighted). The main content area is titled "Password Setting" and contains the following text: "For the first time to enable password function, set password before you enable it. When password function is enabled, the Administrator/User Password will be required when you connect to the web server." Below this text, there is a section labeled "Administrator" with three rows of input fields: "Password" with radio buttons for "Enable" and "Disable" (the "Disable" option is selected) and a "Submit" button; "New Password" with a text input field; and "Confirm Password" with a text input field and a "Submit" button.

Use Password Setting to set up an administrator password to access the Web Management . When enabling password for the first time, set the password before enabling it. When the password function is enabled, the administrator password will be required for accessing the Web Management.

Troubleshooting Your Projector

If you experience problems with your projector, see the following troubleshooting tips. If the problem persists, contact Dell.

Problem	Possible Solution
No image appears on the screen	<ul style="list-style-type: none">• Ensure that the lens cap is removed and the projector turned on.• Ensure the external graphics port is enabled. If you are using a Dell portable computer, press  . For other computers, see your documentation.• Ensure that all the cables are securely connected. See "Connecting Your Projector" on page 9."• Ensure that the pins of the connectors are not bent or broken.• Ensure that the lamp is securely installed (see "Changing the Lamp" on page 48").• Run Self-diagnostic test. See "Self-diagnostic for Video" on page 48. Ensure that the colors of the test pattern are correct.

Problem (continued)	Possible Solution (continued)
Partial, scrolling, or incorrectly displayed image	<ul style="list-style-type: none"> • Press the Resync button on the remote control or the control panel. • If you are using a Dell portable computer, set the resolution of the computer to XGA (1024 x 768): <ul style="list-style-type: none"> a Right-click the unused portion of your Windows desktop, click Properties and then select Settings tab. b Verify the setting is 1024 x 768 pixels for the external monitor port. c Press  . <p>If you experience difficulty in changing resolutions or your monitor freezes, restart all the equipment and the projector.</p> <p>If you are not using a Dell portable computer, see your documentation.</p>
The screen does not display your presentation	If you are using a portable computer, press   .
Image is unstable or flickering	Adjust the tracking in the OSD Computer Source tab.
Image has vertical flickering bar	Adjust the frequency in the OSD Computer Source tab.
Image color is not correct	<ul style="list-style-type: none"> • If your graphic card output signal is sync on Green, and you would like to display VGA at 60Hz signal, please go into OSD select Management, select Signal Type and then select RGB. • Run the Self-diagnostic test (see " Self-diagnostic for video ") for preliminary diagnostic on image color problem. Ensure that the colors of the test pattern are correct.
Image is out of focus	<ol style="list-style-type: none"> 1 Adjust the focus ring on the projector lens. 2 Ensure that the projection screen is within the required distance from the projector (4.9ft [1.5m] to 39.4ft [12m]).

Problem (continued)	Possible Solution (continued)
The image is stretched when displaying a 16:9 DVD	<p>The projector automatically detects a 16:9 DVD and adjusts the aspect ratio to full screen with a 4:3 (letter-box) default setting.</p> <p>If the image is still stretched, adjust the aspect ratio as follows:</p> <ul style="list-style-type: none"> • If you are playing a 16:9 DVD, select 4:3 aspect ratio type on your DVD player (if capable). • If you cannot select 4:3 aspect ratio type on your DVD player, select 4:3 aspect ratio in the Image Settings menu in the OSD.
Image is reversed	Select Management from the OSD and adjust the projection mode.
Lamp is burned out or makes a popping sound	When the lamp reaches its end of life, it may burn out and may make a loud popping sound. If this occurs, the projector does not turn back on, and displays Lamp Defective in the LCD display until the lamp is replaced. To replace the lamp, see "Changing the Lamp" on page 48.
LAMP light is solid orange	If LAMP light is solid orange, replace the lamp.
Interlock failed	If the LAMP light is blinking orange, the lamp cover is not closed properly. Close the lamp cover properly. If the problem persists, contact Dell.
TEMP light is solid orange	The projector has overheated. The display automatically shuts down. Turn the display on again after the projector cools down. If the problem persists, contact Dell.
TEMP light is blinking orange	A projector fan has failed and the projector will automatically shut down. If the problem persists, contact Dell.
The remote control is not operating smoothly or in very limited range	The battery may be low. Check if the laser beam transmitted from the remote is too dim. If so, replace with 2 new AA batteries.

Self-diagnostic for Video

Dell 5100MP Projector provides self-diagnostic test of the projector video display (for Video, S-video, Component-i). Use this advanced feature for preliminary self-diagnostic on your projector when encountering a display problem for video.

- 1 After turning on the projector, press "+" and "-" buttons on the control panel simultaneously for 3 seconds and release the buttons when screen goes blank.
- 2 Press "+" and "-" buttons again to exit the diagnostic mode.
- 3 While in Self-diagnostic mode, the screen will run a seven-color-cycle test as following:
Red--> Green--> Blue--> White--> Watchet Blue--> Dark Green--> Yellow.
Ensure that the colors of the test pattern are correct. Contact Dell if the colors are not displayed correctly.

Changing the Lamp

Replace the lamp when you see "Lamp is approaching the end of its useful life in full power operation. Replacement suggested! www.dell.com/lamps" appears on the screen. If this problem persists after replacing the lamp, contact Dell.



CAUTION: The lamp becomes very hot when in use. Do not attempt to replace the lamp until the projector has been allowed to cool down for at least 30 minutes.



CAUTION: Do not touch the bulb or the lamp glass at any time. The bulb may explode due to improper handling, including the touching of the bulb or the lamp glass.

- 1 Turn off the projector and disconnect the power cord.
- 2 Let the projector cool for at least 30 minutes.
- 3 Loosen the 2 screws that secure the lamp cover, and remove the cover.
- 4 Loosen the 2 screws that secure the lamp.

5 Pull up the lamp by its metal handle.

6 Reverse steps 1 through 5 to install the new lamp.

7 Reset the lamp by usage time selecting the left **Lamp Reset** icon in the OSD Management tab.

 **NOTE:** Dell may require that lamps replaced under warranty be returned to Dell. Otherwise, contact your local waste disposal agency for the address of the nearest deposit site.

 **NOTE:** The lamp contains mercury. Disposal of this material may be regulated due to environmental considerations. For disposal or recycling information, please contact your local authorities or the Electronic Industries Alliance: www.eiae.org.

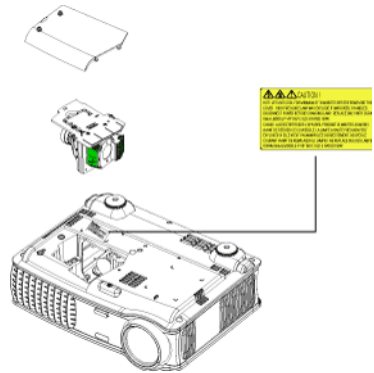

Specifications

Light Valve	Single-chip 0.95" SXGA+ DLP™ LVDS (low-voltage differential signaling) technology
Brightness	3000 ANSI Lumens (Max.)
Contrast Ratio	2000:1 Typical (Full On/Full Off)
Uniformity	80% Typical (Japan Standard - JBMA)
Lamp	300-watt user-replaceable 1700-hour lamp (up to 2200 hours in eco mode)
Number of Pixels	1400 x 1050 (SXGA+)
Displayable Color	16.7M colors
Color Wheel Speed	100~127.5Hz(2X)
Projection Lens	F/2.6~2.87, f=39.1~46.92mm with 1.2x manual zoom lens
Projection Screen Size	30.8-295.3 inches (diagonal)
Projection Distance	4.9~39.4 ft (1.5m~12m)
Video Compatibility	NTSC, NTSC 4.43, PAL, PAL-M, PAL-N, SECAM, and HDTV (1080i, 720p, 576i/p, 480i/p) compatibility Composite video, Component video and S-video capability
H. Frequency	15 kHz- 100 kHz (Analog) 30 kHz- 64 kHz (Digital)
V. Frequency	43 Hz- 120 Hz (Analog) 43 Hz- 85 Hz (Digital)
Power Supply	Universal 90-240V AC 50-60Hz with PFC input

Power Consumption	400 watts typical, 335 watts in eco mode
Audio	2 speakers, 3 watts RMS
Noise Level	37dB(A) Full-on mode, 34dB(A) Eco-mode
Weight	8.2 lbs (3.73 kgs)
Dimensions (W x H x D)	External 13 x 10.3 x 4.5 ± 0.04 inches (329.8 x 261.4 x 115.2 ± 1mm)
Environmental	Operating temperature: 5°C - 35°C (41°F - 95°F) Humidity: 80% maximum Storage temperature: -20°C to 60°C (-4°F to 140°F) Humidity: 80% maximum
Regulatory	FCC, CE, VCCI, UL, cUL, TÜV- GS, ICES-003, MIC, C-Tick, GOST, PCBC, CCC, PSB, EZU, NOM, S-TuV/Argentina
Networking Protocol	10/100 Base-T TCP/IP ICMP ARP SNMP V1.0 SMTP DHCP HTTP
I/O Connectors	Power: AC power input socket Computer input: one MI-DA for analog/digital/component, HDTV input signals, one 15-pin D-sub for analog input/component, HDTV input signals, one BNC R/G/B/H/V for analog RGB input signals. Computer output: one 15-pin D-sub

Video input: 3 RCA connectors for component video/ HDTV input, one mini-DIN 4-pin S-video input, one RCA jack for composite video input

Audio input: one phone jack (diameter 3.5mm)

DC jack 12 volt @ 200mA output, relay control for automatic projection screen control

One RJ45 connector for networking

One HDMI input

One mini-DIN RS232 for wired remote projector control from PC

RS232 Pin Assignment

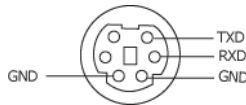

RS232 Protocol

- Communication Settings

Connection settings	Value
Baud Rate:	19200
Data Bits:	8
Parity	None
Stop Bits	1

- Control command Syntax (From PC to Projector)

[H][AC][SoP][CRC][ID][SoM][COMMAND]

- Example: power on the projector

Enter the following code: 0xBE 0xEF 0x10 0x05 0x00 0xC7 0xBF 0x11 0x11 0x01 0x00 0x02

- Control Commands List

Go to support.dell.com to view the latest RS232 code.

PIP combination sources

Source	M1 RGB	M1 Component	VGA Computer	VGA Component	BNC RGB	BNC Component	RCA Component	HDMI	SCART
S-Video	PIP	PIP	PIP	PIP	PIP	PIP	PIP	PIP	PIP
Composite	PIP	PIP	PIP	PIP	PIP	PIP	PIP	PIP	PIP
M1 Digital	X	X	PIP	PIP	PIP	PIP	PIP	PIP	PIP



NOTE: If two sources combination overpass the bandwidth of the scaler, the projector will show the black image.

Compatibility Modes

Mode	Resolution	(ANALOG)		(DIGITAL)	
		V. Frequency (Hz)	H. Frequency (KHz)	V. Frequency (Hz)	H. Frequency (KHz)
VGA	640X350	70	31.5	70	31.5
VGA	640X350	85	37.9	85	37.9
VGA	640X400	85	37.9	85	37.9
VGA	640X480	60	31.5	60	31.5
VGA	640X480	72	37.9	72	37.9
VGA	640X480	75	37.5	75	37.5
VGA	640X480	85	43.3	85	43.3
VGA	720X400	70	31.5	70	31.5
VGA	720X400	85	37.9	85	37.9
SVGA	800X600	56	35.2	56	35.2
SVGA	800X600	60	37.9	60	37.9
SVGA	800X600	72	48.1	72	48.1
SVGA	800X600	75	46.9	75	46.9
SVGA	800X600	85	53.7	85	53.7
XGA	1024X768	43.4	35.5	-	-
XGA	1024X768	60	48.4	60	48.4
XGA	1024X768	70	56.5	70	56.5
XGA	1024X768	75	60	75	60
XGA	1024X768	85	68.7	-	-
SXGA	1280X1024	60	63.98	60	63.98
SXGA	1280X1024	75	79.98	-	-
SXGA	1280x1024	85	91.1	-	-
*SXGA+	1400x1050	60	63.98	-	-
*UXGA	1600x1200	60	75	-	-
MAC LC13*	640X480	66.66	34.98	-	-
MAC II 13*	640X480	66.68	35	-	-
MAC 16*	832X624	74.55	49.725	-	-
MAC 19*	1024X768	75	60.24	-	-
*MAC	1152X870	75.06	68.68	-	-
MAC G4	640X480	60	31.35	-	-

MAC G4	640X480	120	68.03	-	-
MAC G4	640X480	120	97.09	-	-
IMAC DV	640X480	117	60	-	-
IMAC DV	800X600	95	60	-	-
IMAC DV	1024X768	75	60	-	-
IMAC DV	1152X870	75	68.49	-	-
IMAC DV	1280X960	75	75	-	-
IMAC DV	1280X1024	85	91.1	-	-
* Compressed computer image.					



NOTE: UXGA is not supported in the DVI (M1-to-DVI).

Contacting Dell

To contact Dell electronically, you can access the following websites:

- www.dell.com
- support.dell.com (technical support)
- premiersupport.dell.com (technical support for educational, government, healthcare, and medium/large business customers, including Premier, Platinum, and Gold customers)

For specific web addresses for your country, find the appropriate country section in the table below.

NOTE: Toll-free numbers are for use within the country for which they are listed.

NOTE: In certain countries, technical support specific to Dell Inspiron™ XPS computers is available at a separate telephone number listed for participating countries. If you do not see a telephone number listed that is specific for Inspiron XPS computers, you may contact Dell through the technical support number listed and your call will be routed appropriately.

When you need to contact Dell, use the electronic addresses, telephone numbers, and codes provided in the following table. If you need assistance in determining which codes to use, contact a local or an international operator.

Country (City) International Access Code Country Code City Code	Department Name or Service Area, Website and E-Mail Address	Area Codes, Local Numbers, and Toll-Free Numbers
Anguilla	General Support	toll-free: 800-335-0031
Antigua and Barbuda	General Support	1-800-805-5924

Country (City) International Access Code Country Code City Code	Department Name or Service Area, Website and E-Mail Address	Area Codes, Local Numbers, and Toll-Free Numbers
Argentina (Buenos Aires) International Access Code: 00 Country Code: 54 City Code: 11	Website: www.dell.com.ar E-mail: us_latin_services@dell.com E-mail for desktop and portable computers: la-techsupport@dell.com E-mail for servers and EMC® storage products: la_enterprise@dell.com	Customer Care toll-free: 0-800-444-0730 Tech Support toll-free: 0-800-444-0733 Tech Support Services toll-free: 0-800-444-0724 Sales 0-810-444-3355
Aruba	General Support	toll-free: 800-1578

Country (City) International Access Code Country Code City Code	Department Name or Service Area, Website and E-Mail Address	Area Codes, Local Numbers, and Toll-Free Numbers
Australia (Sydney)	E-mail (Australia): au_tech_support@dell.com	
International Access Code: 0011	E-mail (New Zealand): nz_tech_support@dell.com	
Country Code: 61	Home and Small Business	1-300-655-533
City Code: 2	Government and Business	toll-free: 1-800-633-559
	Preferred Accounts Division (PAD)	toll-free: 1-800-060-889
	Customer Care	toll-free: 1-800-819-339
	Technical Support (portables and desktops)	toll-free: 1-300-655-533
	Technical Support (servers and workstations)	toll-free: 1-800-733-314
	Corporate Sales	toll-free: 1-800-808-385
	Transaction Sales	toll-free: 1-800-808-312
	Fax	toll-free: 1-800-818-341

Country (City) International Access Code Country Code City Code	Department Name or Service Area, Website and E-Mail Address	Area Codes, Local Numbers, and Toll-Free Numbers
Austria (Vienna)	Website: support.euro.dell.com	
International	E-mail:	
Access Code: 900	tech_support_central_europe@de	
Country Code: 43	ll.com	
City Code: 1	Home/Small Business Sales	0820 240 530 00
	Home/Small Business Fax	0820 240 530 49
	Home/Small Business Customer Care	0820 240 530 14
	Preferred Accounts/Corporate Customer Care	0820 240 530 16
	Home/Small Business Technical Support	0820 240 530 14
	Preferred Accounts/Corporate Technical Support	0660 8779
	Switchboard	0820 240 530 00
Bahamas	General Support	toll-free: 1-866-278-6818
Barbados	General Support	1-800-534-3066

Country (City) International Access Code Country Code City Code	Department Name or Service Area, Website and E-Mail Address	Area Codes, Local Numbers, and Toll-Free Numbers
Belgium (Brussels) International Access Code: 00 Country Code: 32 City Code: 2	Website: support.euro.dell.com E-mail for French-speaking Customers: support.euro.dell.com/be/fr/email dell/ Technical Support for Inspiron XPS computers only Technical Support for all other Dell computers Technical Support Fax Customer Care Corporate Sales Fax Switchboard	02 481 92 96 02 481 92 88 02 481 92 95 02 713 15 .65 02 481 91 00 02 481 92 99 02 481 91 00
Bermuda	General Support	1-800-342-0671
Bolivia	General Support	toll-free: 800-10-0238
Brazil International Access Code: 00 Country Code: 55 City Code: 51	Website: www.dell.com/br Customer Support, Technical Support Technical Support Fax Customer Care Fax Sales	0800 90 3355 51 481 5470 51 481 5480 0800 90 3390
British Virgin Islands	General Support	toll-free: 1-866-278-6820

Country (City) International Access Code Country Code City Code	Department Name or Service Area, Website and E-Mail Address	Area Codes, Local Numbers, and Toll-Free Numbers
Brunei Country Code: 673	Customer Technical Support (Penang, Malaysia)	604 633 4966
	Customer Service (Penang, Malaysia)	604 633 4949
	Transaction Sales (Penang, Malaysia)	604 633 4955
Canada (North York, Ontario) International Access Code: 011	Online Order Status: www.dell.ca/ostatus	
	AutoTech (automated technical support)	toll-free: 1-800-247-9362
	Customer Care (Home Sales/Small Business)	toll-free: 1-800-847-4096
	Customer Care (med./large business, government)	toll-free: 1-800-326-9463
	Technical Support (Home Sales/Small Business)	toll-free: 1-800-847-4096
	Technical Support (med./large bus., government)	toll-free: 1-800-387-5757
	Technical Support (printers, projectors, televisions, handhelds, digital jukebox, and wireless)	1-877-335-5767
	Sales (Home Sales/Small Business)	toll-free: 1-800-387-5752
	Sales (med./large bus., government)	toll-free: 1-800-387-5755
	Spare Parts Sales & Extended Service Sales	1 866 440 3355
Cayman Islands	General Support	1-800-805-7541
Chile (Santiago) Country Code: 56 City Code: 2	Sales, Customer Support, and Technical Support	toll-free: 1230-020-4823

Country (City) International Access Code Country Code City Code	Department Name or Service Area, Website and E-Mail Address	Area Codes, Local Numbers, and Toll-Free Numbers
China (Xiamen) Country Code: 86 City Code: 592	Technical Support website: support.dell.com.cn Technical Support E-mail: cn_support@dell.com Customer Care E-mail: customer_cn@dell.com	
	Technical Support Fax	592 818 1350
	Technical Support (Dell™ Dimension™ and Inspiron)	toll-free: 800 858 2969
	Technical Support (OptiPlex™, Latitude™, and Dell Precision™)	toll-free: 800 858 0950
	Technical Support (servers and storage)	toll-free: 800 858 0960
	Technical Support (projectors, PDAs, switches, routers, and so on)	toll-free: 800 858 2920
	Technical Support (printers)	toll-free: 800 858 2311
	Customer Care	toll-free: 800 858 2060
	Customer Care Fax	592 818 1308
	Home and Small Business	toll-free: 800 858 2222
	Preferred Accounts Division	toll-free: 800 858 2557
	Large Corporate Accounts GCP	toll-free: 800 858 2055
	Large Corporate Accounts Key Accounts	toll-free: 800 858 2628
	Large Corporate Accounts North	toll-free: 800 858 2999
	Large Corporate Accounts North Government and Education	toll-free: 800 858 2955
	Large Corporate Accounts East	toll-free: 800 858 2020
	Large Corporate Accounts East Government and Education	toll-free: 800 858 2669

Country (City) International Access Code Country Code City Code	Department Name or Service Area, Website and E-Mail Address	Area Codes, Local Numbers, and Toll-Free Numbers
	Large Corporate Accounts Queue Team	toll-free: 800 858 2572
	Large Corporate Accounts South	toll-free: 800 858 2355
	Large Corporate Accounts West	toll-free: 800 858 2811
	Large Corporate Accounts Spare Parts	toll-free: 800 858 2621
Colombia	General Support	980-9-15-3978
Costa Rica	General Support	0800-012-0435
Czech Republic (Prague)	Website: support.euro.dell.com E-mail: czech_dell@dell.com	
International Access Code: 00	Technical Support	22537 2727
Country Code: 420	Customer Care	22537 2707
	Fax	22537 2714
	Tech Fax	22537 2728
	Switchboard	22537 2711

Country (City) International Access Code Country Code City Code	Department Name or Service Area, Website and E-Mail Address	Area Codes, Local Numbers, and Toll-Free Numbers
Denmark (Copenhagen)	Website: support.euro.dell.com E-mail:	
International Access Code: 00	support.euro.dell.com/dk/da/emai	
Country Code: 45	Technical Support for Inspiron XPS computers only	7010 0074
	Technical Support for all other Dell computers	7023 0182
	Customer Care (Relational)	7023 0184
	Home/Small Business Customer Care	3287 5505
	Switchboard (Relational)	3287 1200
	Switchboard Fax (Relational)	3287 1201
	Switchboard (Home/Small Business)	3287 5000
	Switchboard Fax (Home/Small Business)	3287 5001
Dominica	General Support	toll-free: 1-866-278-6821
Dominican Republic	General Support	1-800-148-0530
Ecuador	General Support	toll-free: 999-119
El Salvador	General Support	01-899-753-0777

Country (City) International Access Code Country Code City Code	Department Name or Service Area, Website and E-Mail Address	Area Codes, Local Numbers, and Toll-Free Numbers
Finland (Helsinki)	Website: support.euro.dell.com E-mail: support.euro.dell.com/fi/fi/emaildell/	
International Access Code: 990	Technical Support	09 253 313 60
Country Code: 358	Customer Care	09 253 313 38
City Code: 9	Fax	09 253 313 99
	Switchboard	09 253 313 00

Country (City) International Access Code Country Code City Code	Department Name or Service Area, Website and E-Mail Address	Area Codes, Local Numbers, and Toll-Free Numbers
France (Paris) (Montpellier)	Website: support.euro.dell.com E-mail: support.euro.dell.com/fr/fr/emaildell/	
International Access Code: 00 Country Code: 33	Home and Small Business	
City Codes: (1) (4)	Technical Support for Inspiron XPS computers only	0825 387 129
	Technical Support for all other Dell computers	0825 387 270
	Customer Care	0825 823 833
	Switchboard	0825 004 700
	Switchboard (calls from outside of France)	04 99 75 40 00
	Sales	0825 004 700
	Fax	0825 004 701
	Fax (calls from outside of France)	04 99 75 40 01
	Corporate	
	Technical Support	0825 004 719
	Customer Care	0825 338 339
	Switchboard	01 55 94 71 00
	Sales	01 55 94 71 00
	Fax	01 55 94 71 01

Country (City) International Access Code Country Code City Code	Department Name or Service Area, Website and E-Mail Address	Area Codes, Local Numbers, and Toll-Free Numbers
Germany (Langen) International Access Code: 00 Country Code: 49 City Code: 6103	Website: support.euro.dell.com	
	E-mail: tech_support_central_europe@ dell.com	
	Technical Support for Inspiron XPS computers only	06103 766-7222
	Technical Support for all other Dell computers	06103 766-7200
	Home/Small Business Customer Care	0180-5-224400
	Global Segment Customer Care	06103 766-9570
	Preferred Accounts Customer Care	06103 766-9420
	Large Accounts Customer Care Public Accounts Customer Care Switchboard	06103 766-9560 06103 766-9555 06103 766-7000
Greece	Website: support.euro.dell.com	
	E-mail: support.euro.dell.com/gr/en/ email/dell/	
	Technical Support	00800-44 14 95 18
	Gold Service Technical Support	00800-44 14 00 83
	Switchboard	2108129810
	Gold Service Switchboard	2108129811
	Sales Fax	2108129800 2108129812
Grenada	General Support	toll-free: 1-866-540-3355
Guatemala	General Support	1-800-999-0136
Guyana	General Support	toll-free: 1-877-270-4609

Country (City) International Access Code Country Code City Code	Department Name or Service Area, Website and E-Mail Address	Area Codes, Local Numbers, and Toll-Free Numbers
Hong Kong	Website: support.ap.dell.com	
International Access Code: 001	Technical Support E-mail: apsupport@dell.com	
Country Code: 852	Technical Support (Dimension and Inspiron)	2969 3188
	Technical Support (OptiPlex, Latitude, and Dell Precision)	2969 3191
	Technical Support (PowerApp™, PowerEdge™, PowerConnect™, and PowerVault™)	2969 3196
	Customer Care	3416 0910
	Large Corporate Accounts	3416 0907
	Global Customer Programs	3416 0908
	Medium Business Division	3416 0912
	Home and Small Business Division	2969 3105
India	Technical Support	1600 33 8045
	Sales (Large Corporate Accounts)	1600 33 8044
	Sales (Home and Small Business)	1600 33 8046

Country (City) International Access Code Country Code City Code	Department Name or Service Area, Website and E-Mail Address	Area Codes, Local Numbers, and Toll-Free Numbers
Ireland (Cherrywood) International Access Code: 16 Country Code: 353 City Code: 1	Website: support.euro.dell.com	
	E-mail: dell_direct_support@dell.com	
	Technical Support for Inspiron XPS computers only	1850 200 722
	Technical Support for all other Dell computers	1850 543 543
	U.K. Technical Support (dial within U.K. only)	0870 908 0800
	Home User Customer Care	01 204 4014
	Small Business Customer Care	01 204 4014
	U.K. Customer Care (dial within U.K. only)	0870 906 0010
	Corporate Customer Care	1850 200 982
	Corporate Customer Care (dial within U.K. only)	0870 907 4499
	Ireland Sales	01 204 4444
	U.K. Sales (dial within U.K. only)	0870 907 4000
	Fax/Sales Fax	01 204 0103
	Switchboard	01 204 4444

Country (City) International Access Code Country Code City Code	Department Name or Service Area, Website and E-Mail Address	Area Codes, Local Numbers, and Toll-Free Numbers
Italy (Milan)	Website: support.euro.dell.com	
International Access Code: 00 Country Code: 39 City Code: 02	E-mail: support.euro.dell.com/it/it/emaildell/ Home and Small Business	
	Technical Support	02 577 826 90
	Customer Care	02 696 821 14
	Fax	02 696 821 13
	Switchboard	02 696 821 12
	Corporate	
	Technical Support	02 577 826 90
	Customer Care	02 577 825 55
	Fax	02 575 035 30
	Switchboard	02 577 821
Jamaica	General Support (dial from within Jamaica only)	1-800-682-3639
Japan (Kawasaki)	Website: support.jp.dell.com	
International Access Code: 001 Country Code: 81 City Code: 44	Technical Support (servers)	toll-free: 0120-198-498
	Technical Support outside of Japan (servers)	81-44-556-4162
	Technical Support (Dimension and Inspiron)	toll-free: 0120-198-226
	Technical Support outside of Japan (Dimension and Inspiron)	81-44-520-1435
	Technical Support (Dell Precision, OptiPlex, and Latitude)	toll-free:0120-198-433
	Technical Support outside of Japan (Dell Precision, OptiPlex, and Latitude)	81-44-556-3894

Country (City) International Access Code Country Code City Code	Department Name or Service Area, Website and E-Mail Address	Area Codes, Local Numbers, and Toll-Free Numbers
	Technical Support (PDAs, projectors, printers, routers)	toll-free: 0120-981-690
	Technical Support outside of Japan (PDAs, projectors, printers, routers)	81-44-556-3468
	Faxbox Service	044-556-3490
	24-Hour Automated Order Service	044-556-3801
	Customer Care	044-556-4240
	Business Sales Division (up to 400 employees)	044-556-1465
	Preferred Accounts Division Sales (over 400 employees)	044-556-3433
	Large Corporate Accounts Sales (over 3500 employees)	044-556-3430
	Public Sales (government agencies, educational institutions, and medical institutions)	044-556-1469
	Global Segment Japan	044-556-3469
	Individual User	044-556-1760
	Switchboard	044-556-4300
Korea (Seoul)	Technical Support	toll-free: 080-200-3800
International	Sales	toll-free: 080-200-3600
Access Code: 001	Customer Service (Penang, Malaysia)	604 633 4949
Country Code: 82	Fax	2194-6202
City Code: 2	Switchboard	2194-6000
	Technical Support (Electronics and Accessories)	toll-free: 080-200-3801

Country (City) International Access Code Country Code City Code	Department Name or Service Area, Website and E-Mail Address	Area Codes, Local Numbers, and Toll-Free Numbers
Latin America	Customer Technical Support (Austin, Texas, U.S.A.)	512 728-4093
	Customer Service (Austin, Texas, U.S.A.)	512 728-3619
	Fax (Technical Support and Customer Service) (Austin, Texas, U.S.A.)	512 728-3883
	Sales (Austin, Texas, U.S.A.)	512 728-4397
	SalesFax (Austin, Texas, U.S.A.)	512 728-4600 or 512 728-3772
Luxembourg International Access Code: 00 Country Code: 352	Website: support.euro.dell.com	
	E-mail: tech_be@dell.com	
	Technical Support (Brussels, Belgium)	3420808075
	Home/Small Business Sales (Brussels, Belgium)	toll-free: 080016884
	Corporate Sales (Brussels, Belgium)	02 481 91 00
	Customer Care (Brussels, Belgium)	02 481 91 19
	Fax (Brussels, Belgium)	02 481 92 99
Switchboard (Brussels, Belgium)	02 481 91 00	
Macao Country Code: 853	Technical Support	toll-free: 0800 105
	Customer Service (Xiamen, China)	34 160 910
	Transaction Sales (Xiamen, China)	29 693 115

Country (City) International Access Code Country Code City Code	Department Name or Service Area, Website and E-Mail Address	Area Codes, Local Numbers, and Toll-Free Numbers
Malaysia (Penang) International Access Code: 00 Country Code: 60 City Code: 4	Website: support.ap.dell.com	
	Technical Support (Dell Precision, OptiPlex, and Latitude)	toll-free: 1 800 88 0193
	Technical Support (Dimension, Inspiron, and Electronics and Accessories)	toll-free: 1 800 88 1306
	Technical Support (PowerApp, PowerEdge, PowerConnect, and PowerVault)	toll-free: 1800 88 1386
	Customer Service (Penang, Malaysia)	04 633 4949
	Transaction Sales	toll-free: 1 800 888 202
	Corporate Sales	toll-free: 1 800 888 213
Mexico International Access Code: 00 Country Code: 52	Customer Technical Support	001-877-384-8979 or 001-877-269-3383
	Sales	50-81-8800 or 01-800-888-3355
	Customer Service	001-877-384-8979 or 001-877-269-3383
	Main	50-81-8800 or 01-800-888-3355
	General Support	toll-free: 1-866-278-6822
Montserrat	General Support	toll-free: 1-866-278-6822
Netherlands Antilles	General Support	001-800-882-1519

Country (City) International Access Code Country Code City Code	Department Name or Service Area, Website and E-Mail Address	Area Codes, Local Numbers, and Toll-Free Numbers
Netherlands (Amsterdam) International Access Code: 00 Country Code: 31 City Code: 20	Website: support.euro.dell.com	
	Technical Support for Inspiron XPS computers only	020 674 45 94
	Technical Support for all other Dell computers	020 674 45 00
	Technical Support Fax	020 674 47 66
	Home/Small Business Customer Care	020 674 42 00
	Relational Customer Care	020 674 4325
	Home/Small Business Sales	020 674 55 00
	Relational Sales	020 674 50 00
	Home/Small Business Sales Fax	020 674 47 75
	Relational Sales Fax	020 674 47 50
New Zealand International Access Code: 00 Country Code: 64	Switchboard	020 674 50 00
	Switchboard Fax	020 674 47 50
	E-mail (New Zealand): nz_tech_support@dell.com	
	E-mail (Australia): au_tech_support@dell.com	
	Technical Support (for desktop and portable computers)	toll-free: 0800 446 255
	Technical Support (for servers and workstations)	toll-free: 0800 443 563
	Home and Small Business	0800 446 255
	Government and Business Sales	0800 444 617
Fax	0800 441 567	
Nicaragua	General Support	001-800-220-1006

Country (City) International Access Code Country Code City Code	Department Name or Service Area, Website and E-Mail Address	Area Codes, Local Numbers, and Toll-Free Numbers
Norway (Lysaker)	Website: support.euro.dell.com	
International Access Code: 00 Country Code: 47	E-mail: support.euro.dell.com/no/no/emai ldell/	
	Technical Support	671 16882
	Relational Customer Care	671 17575
	Home/Small Business Customer Care	23162298
	Switchboard	671 16800
	Fax Switchboard	671 16865
Panama	General Support	001-800-507-0962
Peru	General Support	0800-50-669
Poland (Warsaw)	Website: support.euro.dell.com	
International Access Code: 011	E-mail: pl_support_tech@dell.com	
Country Code: 48	Customer Service Phone	57 95 700
City Code: 22	Customer Care	57 95 999
	Sales	57 95 999
	Customer Service Fax	57 95 806
	Reception Desk Fax	57 95 998
	Switchboard	57 95 999

Country (City) International Access Code Country Code City Code	Department Name or Service Area, Website and E-Mail Address	Area Codes, Local Numbers, and Toll-Free Numbers
Portugal	Website: support.euro.dell.com	
International Access Code: 00 Country Code: 351	E-mail: <a href="mailto:support.euro.dell.com/pt/en/emai
ldell/">support.euro.dell.com/pt/en/emai ldell/ Technical Support Customer Care Sales Fax	707200149 800 300 413 800 300 410 or 800 300 411 or 800 300 412 or 21 422 07 10 21 424 01 12
Puerto Rico	General Support	1-800-805-7545
St. Kitts and Nevis	General Support	toll-free: 1-877-441-4731
St. Lucia	General Support	1-800-882-1521
St. Vincent and the Grenadines	General Support	toll-free: 1-877-270-4609
Singapore (Singapore)	Website: support.ap.dell.com	
International Access Code: 005 Country Code: 65	Technical Support (Dimension, Inspiron, and Electronics and Accessories) Technical Support (OptiPlex, Latitude, and Dell Precision) Technical Support (PowerApp, PowerEdge, PowerConnect, and PowerVault) Customer Service (Penang, Malaysia) Transaction Sales Corporate Sales	toll-free: 1800 394 7430 toll-free: 1800 394 7488 toll-free: 1800 394 7478 604 633 4949 toll-free: 1 800 394 7412 toll-free: 1 800 394 7419

Country (City) International Access Code Country Code City Code	Department Name or Service Area, Website and E-Mail Address	Area Codes, Local Numbers, and Toll-Free Numbers
Slovakia (Prague)	Website: support.euro.dell.com	
International Access Code: 00	E-mail: czech_dell@dell.com	
Country Code: 421	Technical Support	02 5441 5727
	Customer Care	420 22537 2707
	Fax	02 5441 8328
	Tech Fax	02 5441 8328
	Switchboard (Sales)	02 5441 7585
South Africa (Johannesburg)	Website: support.euro.dell.com	
International Access Code: 09/091	E-mail: dell_za_support@dell.com	
Country Code: 27	Gold Queue	011 709 7713
City Code: 11	Technical Support	011 709 7710
	Customer Care	011 709 7707
	Sales	011 709 7700
	Fax	011 706 0495
	Switchboard	011 709 7700
Southeast Asian and Pacific Countries	Customer Technical Support, Customer Service, and Sales (Penang, Malaysia)	604 633 4810

Country (City) International Access Code Country Code City Code	Department Name or Service Area, Website and E-Mail Address	Area Codes, Local Numbers, and Toll-Free Numbers
Spain (Madrid)	Website: support.euro.dell.com	
International	E-mail:	
Access Code: 00	support.euro.dell.com/es/es/email	
Country Code: 34	dell/	
City Code: 91	Home and Small Business	
	Technical Support	902 100 130
	Customer Care	902 118 540
	Sales	902 118 541
	Switchboard	902 118 541
	Fax	902 118 539
	Corporate	
	Technical Support	902 100 130
	Customer Care	902 115 236
	Switchboard	91 722 92 00
	Fax	91 722 95 83
Sweden (Upplands Vasby)	Website: support.euro.dell.com	
International	E-mail:	
Access Code: 00	support.euro.dell.com/se/sv/email	
Country Code: 46	dell/	
City Code: 8	Technical Support	08 590 05 199
	Relational Customer Care	08 590 05 642
	Home/Small Business Customer Care	08 587 70 527
	Employee Purchase Program (EPP) Support	20 140 14 44
	Technical Support Fax	08 590 05 594
	Sales	08 590 05 185

Country (City) International Access Code Country Code City Code	Department Name or Service Area, Website and E-Mail Address	Area Codes, Local Numbers, and Toll-Free Numbers
Switzerland (Geneva)	Website: support.euro.dell.com E-mail:	
International Access Code: 00	Tech_support_central_Europe@dell.com	
Country Code: 41 City Code: 22	E-mail for French-speaking HSB and Corporate Customers: support.euro.dell.com/ch/fr/emaildell/	
	Technical Support (Home and Small Business)	0844 811 411
	Technical Support (Corporate)	0844 822 844
	Customer Care (Home and Small Business)	0848 802 202
	Customer Care (Corporate)	0848 821 721
	Fax	022 799 01 90
	Switchboard	022 799 01 01
Taiwan	Website: support.ap.dell.com	
International Access Code: 002	E-mail: ap_support@dell.com	
Country Code: 886	Technical Support (OptiPlex, Latitude, Inspiron, Dimension, and Electronics and Accessories)	toll-free: 00801 86 1011
	Technical Support (PowerApp, PowerEdge, PowerConnect, and PowerVault)	toll-free: 00801 60 1256
	Transaction Sales	toll-free: 00801 65 1228
	Corporate Sales	toll-free: 00801 651 227

Country (City) International Access Code Country Code City Code	Department Name or Service Area, Website and E-Mail Address	Area Codes, Local Numbers, and Toll-Free Numbers
Thailand	Website: support.ap.dell.com	
International Access Code: 001	Technical Support (OptiPlex, Latitude, and Dell Precision)	toll-free: 1800 0060 07
Country Code: 66	Technical Support (PowerApp, PowerEdge, PowerConnect, and PowerVault)	toll-free: 1800 0600 09
	Customer Service (Penang, Malaysia)	604 633 4949
	Corporate Sales	toll-free: 1800 006 009
	Transaction Sales	toll-free: 1800 006 006
Trinidad/Tobago	General Support	1-800-805-8035
Turks and Caicos Islands	General Support	toll-free: 1-866-540-3355

Country (City) International Access Code Country Code City Code	Department Name or Service Area, Website and E-Mail Address	Area Codes, Local Numbers, and Toll-Free Numbers
U.K. (Bracknell)	Website: support.euro.dell.com	
International Access Code: 00	Customer Care website: support.euro.dell.com/uk/en/ECare/Form/Home.asp	
Country Code: 44		
City Code: 1344	E-mail: dell_direct_support@dell.com	
	Technical Support (Corporate/Preferred Accounts/PAD [1000+ employees])	0870 908 0500
	Technical Support (direct and general)	0870 908 0800
	Global Accounts Customer Care	01344 373 186
	Home and Small Business Customer Care	0870 906 0010
	Corporate Customer Care	01344 373 185
	Preferred Accounts (500–5000 employees) Customer Care	0870 906 0010
	Central Government Customer Care	01344 373 193
	Local Government & Education Customer Care	01344 373 199
	Health Customer Care	01344 373 194
	Home and Small Business Sales	0870 907 4000
	Corporate/Public Sector Sales	01344 860 456
	Home and Small Business Fax	0870 907 4006
Uruguay	General Support	toll-free: 000-413-598- 2521

Country (City) International Access Code Country Code City Code	Department Name or Service Area, Website and E-Mail Address	Area Codes, Local Numbers, and Toll-Free Numbers
U.S.A. (Austin, Texas) International Access Code: 011 Country Code: 1	Automated Order-Status Service	toll-free: 1-800-433-9014
	AutoTech (portable and desktop computers)	toll-free: 1-800-247-9362
	Consumer (Home and Home Office)	
	Technical Support	toll-free: 1-800-624-9896
	Customer Service	toll-free: 1-800-624-9897
	DellNet™ Service and Support	toll-free: 1-877-Dellnet (1-877-335-5638)
	Employee Purchase Program (EPP) Customers	toll-free: 1-800-695-8133
	Financial Services website: www.dellfinancialservices.com	
	Financial Services (lease/loans)	toll-free: 1-877-577-3355
	Financial Services (Dell Preferred Accounts [DPA])	toll-free: 1-800-283-2210
	Business	
	Customer Service and Technical Support	toll-free: 1-800-822-8965
	Employee Purchase Program (EPP) Customers	toll-free: 1-800-695-8133
	Printers and Projectors Technical Support	toll-free: 1-877-459-7298
	Public (government, education, and healthcare)	
	Customer Service and Technical Support	toll-free: 1-800-456-3355
	Employee Purchase Program (EPP) Customers	toll-free: 1-800-234-1490
Dell Sales	toll-free: 1-800-289-3355 or toll-free: 1-800-879-3355	

Country (City) International Access Code Country Code City Code	Department Name or Service Area, Website and E-Mail Address	Area Codes, Local Numbers, and Toll-Free Numbers
U.S. Virgin Islands	General Support	1-877-673-3355
Venezuela	General Support	8001-3605

Appendix: Regulatory Notices

FCC Notices (U.S. Only)

Most Dell computer systems are classified by the Federal Communications Commission (FCC) as Class B digital devices. To determine which classification applies to your computer system, examine all FCC registration labels located on the bottom, side, or back panel of your computer, on card-mounting brackets, and on the cards themselves. If any one of the labels carries a Class A rating, your entire system is considered to be a Class A digital device. If *all* labels carry an FCC Class B rating as distinguished by either an FCC ID number or the FCC logo, (FCC), your system is considered to be a Class B digital device.

Once you have determined your system's FCC classification, read the appropriate FCC notice. Note that FCC regulations provide that changes or modifications not expressly approved by Dell could void your authority to operate this equipment.

This device complies with Part 15 of the FCC Rules. Operation is subject to the following two conditions:

- This device may not cause harmful interference.
- This device must accept any interference received, including interference that may cause undesired operation.

Class A

This equipment has been tested and found to comply with the limits for a Class A digital device pursuant to Part 15 of the FCC Rules. These limits are designed to provide reasonable protection against harmful interference when the equipment is operated in a commercial environment. This equipment generates, uses, and can radiate radio frequency energy and, if not installed and used in accordance with the manufacturer's instruction manual, may cause harmful interference with radio communications. Operation of this equipment in a residential area is likely to cause harmful interference, in which case you will be required to correct the interference at your own expense.

Class B

This equipment has been tested and found to comply with the limits for a Class B digital device pursuant to Part 15 of the FCC Rules. These limits are designed to provide reasonable protection against harmful interference in a residential installation. This equipment generates, uses, and can radiate radio frequency energy and, if not installed and used in accordance with the manufacturer's instruction manual, may cause interference with radio communications. However, there is no guarantee that interference will not occur in a particular installation. If this equipment does cause harmful interference to radio or television reception, which can be determined by turning the equipment off and on, you are encouraged to try to correct the interference by one or more of the following measures:

- Reorient or relocate the receiving antenna.
- Increase the separation between the equipment and the receiver.
- Connect the equipment into an outlet on a circuit different from that to which the receiver is connected.
- Consult the dealer or an experienced radio/television technician for help.

FCC Identification Information

The following information is provided on the device or devices covered in this document in compliance with FCC regulations:

- Product name: DLP Projector
- Model number: 5100MP/DELL
- Company name:
Dell Inc.
One Dell Way
Round Rock, Texas 78682 USA
512-338-4400

NOM Information (Mexico Only)

The following information is provided on the device(s) described in this document in compliance with the requirements of the official Mexican standards (NOM):

Exporter:	Dell Inc. One Dell Way Round Rock, TX 78682
Importer:	Dell Computer de México, S.A. de C.V. Paseo de la Reforma 2620 - 11° Piso Col. Lomas Altas 11950 México, D.F.
Ship to:	Dell Computer de México, S.A. de C.V. al Cuidado de Kuehne & Nagel de México S. de R.L. Avenida Soles No. 55 Col. Peñon de los Baños 15520 México, D.F.

Model	Supply Voltage	Frequency	Current Consumption
5100MP	AC 100-240 V	50-60 Hz	2.3 A

Glossary

ANSI Lumens— A standard for measuring light output, used for comparing projectors.

Aspect Ratio—The most popular aspect ratio is 4:3 (4 by 3). Early television and computer video formats are in a 4:3 aspect ratio, which means that the width of the image is 4/3 times the height.

Backlit (Backlight)—Refers to a remote control, or a projector control panel, that has buttons and controls that are illuminated.

Bandwidth— The number of cycles per second (Hertz) expressing the difference between the lower and upper limiting frequencies of a frequency band; also, the width of a band of frequencies.

Brightness— The amount of light emitting from a display or projection display or projection device. The brightness of projector is measured by ANSI lumens.

Color Temperature— A method of measuring the whiteness of a light source. Metal halide lamps have a higher temperature compared to halogen or incandescent lights.

Component Video—A method of delivering quality video in a format that contains all the components of the original image. These components are referred to as luma and chroma and are defined as Y'Pb'Pr' for analog component and Y'Cb'Cr' for digital component. Component video is available on DVD players and projectors.

Composite Video — The combined picture signal, including vertical and horizontal blanking and synchronizing signals.

Compression— A function that deletes resolution lines from the image to fit in the display area.

Compressed SVGA— To project an 800x600 image to a VGA projector, the original 800x600 signal must be compressed down. The data displays all the information with only two thirds of the pixels (307,000 vs 480,000). The resulting image is SVGA page size but sacrifices some of the image quality. If you are using an SVGA computers, connecting VGA to a VGA projector, provide better results.

Compressed SXGA— Found on XGA projectors, compressed SXGA handling allows these projectors to handle up to 1280x1024 SXGA resolution.

Compressed XGA— Found on SVGA projectors, compressed XGA handling allows these projectors to handle 1024x768 XGA resolution.

Contrast Ratio— Range of light and dark values in a picture, or the ratio between their maximum and minimum values. There are two methods used by the projection industry to measure the ratio:

- 1 Full On/Off** — measures the ratio of the light output of an all white image (full on) and the light output of an all black (full off) image.
- 2 ANSI** — measures a pattern of 16 alternating black and white rectangles. The average light output from the white rectangles is divided by the average light output of the black rectangles to determine the ANSI contrast ratio.

Full On/Off contrast is always a larger number than ANSI contrast for the same projector.

dB— decibel—A unit used to express relative difference in power or intensity, usually between two acoustic or electric signals, equal to ten times the common logarithm of the ratio of the two levels.

Diagonal Screen— A method of measuring the size of a screen or a projected image. It measures from one corner to the opposite corner. A 9FT high, 12FT wide, screen has a diagonal of 15FT. This document assumes that the diagonal dimensions are for the traditional 4:3 ratio of a computer image as per the example above.

DLP— Digital Light Processing—Reflective display technology developed by Texas Instruments, using small manipulated mirrors. Light passes through a color filter is sent to the DLP mirrors which arrange the RGB colors into a picture projected onto screen, also known as DMD.

DMD— digital Micro- Mirror Device— Each DMD consists of thousands of tilting, microscopic aluminum alloy mirrors mounted on a hidden yoke.

DVI— Digital Visual Interface— Defines the digital interface between digital devices such as projectors and personal computers. For devices that support DVI, a digital to digital connection can be made that eliminates the conversion to analog and thereby delivers an unblemished image.

Focal Length— The distance from the surface of a lens to its focal point.

Frequency— It is the rate of repetition in cycles per seconds of electrical signals. Measured in Hz.

Hz — Frequency of an alternating signal. See Frequency.

Keystone Correction— Device that will correct an image of the distortion (usually a wide-top narrow-bottom effect) of a projected image caused by improper projector to screen angle.

Laser Pointer— A small pen or cigar sized pointer that contains a small battery powered laser, which can project a small, red (typically), high intensity beam of light that is immediately very visible on the screen.

Maximum Distance— The distance from a screen the projector can be to cast an image that is useable (bright enough) in a fully darkened room.

Maximum Image Size— The largest image a projector can throw in a darkened room. This is usually limited by focal range of the optics.

Metal Halide Lamp— The type of lamp used in many medium and all high end portable projectors. These lamps typically have a "half-life" of 1000-2000 hours. That is they slowly lose intensity (brightness) as they are used, and at the "half-life" point, they are half as bright as when new. These lamps output a very "hot" temperature light, similar to mercury vapor lamps used in streetlights.. Their whites are "extremely" white (with slight bluish cast.) and make Halogen lamp's whites look very yellowish by comparison.

Minimum Distance— The closest position that a projector can focus an image onto a screen.

NTSC— The United States broadcast standard for video and broadcasting.

PAL— A European and international broadcast standard for video and broadcasting. Higher resolution than NTSC.

Power Zoom— A zoom lens with the zoom in and out controlled by a motor, usually adjusted from the projector's control panel and also the remote control.

Reverse Image— Feature that allows you to flip the image horizontally. When used in a normal forward projection environment text, graphics, etc, are backwards. Reverse image is used for rear projection.

RGB— Red, Green, Blue— typically used to describe a monitor that requires separate signals for each of the three colors.

S-Video—A video transmission standard that uses a 4-pin mini-DIN connector to send video information on two signal wires called luminance (brightness, Y) and chrominance (color, C). S-Video is also referred to as Y/C.

SECAM— A French and international broadcast standard for video and broadcasting. Higher resolution than NTSC.

SVGA— Super Video Graphics Array— 800 x 600 pixels count.

SXGA— Super Ultra Graphics Array,—1280 x 1024 pixels count.

UXGA— Ultra Extended Graphics Array—1600 x 1200 pixels count.

VGA— Video Graphics Array—640 x 480 pixels count.

XGA— Extra Video Graphics Array— 1024 x 768 pixels count.

Zoom Lens— Lens with a variable focal length that allows operator to move the view in or out making the image smaller or larger.

Zoom Lens Ratio— Is the ratio between the smallest and largest image a lens can projector from a fixed distance. For example, a 1.4:1 zoom lens ratio means that a 10 foot image without zoom would be a 14 foot image with full zoom.

Index

A

- Adjusting the Projected Image 20
 - Adjusting the Projector Height 20
 - lower the projector
 - Elevator button 20
 - Elevator foot 20
 - Tilt adjustment wheel 20
 - Lowering the Projector Height 20
- Adjusting the Projector Zoom and Focus 21
 - Focus ring 21
 - Zoom tab 21

C

- Changing the Lamp 48
- Connecting the Projector
 - 12V DC power cord 15
 - Automatic screen 15
 - BNC to VGA cable 14
 - Commercial RS232 control box 17
 - Composite video cable 14
 - Connecting a Computer with a D-sub to D-sub Cable 11
 - Connecting a Computer with an M1 to D-sub/USB Cable 10
 - Connecting a DVD Player with a D-sub to YPb-

- Pr Cable 12
- Connecting a DVD Player with an M1 to HDTV Cable 12
- Connecting to a DVD Player 12
- Connection with Commercial RS232 Control Box 17
- Connection with PC 16
- D-sub to D-sub cable 11
- D-sub to YPbPr cable 12
- Installation for Driving Automatic Screen 15
- M1 to HDTV cable 12
- M1A to D-sub/USB cable 10
- Power cable 12, 13, 14, 15, 16, 17
- Power cord 10, 11, 12
- RCA to RCA component cable 13
- RS232 cable 16, 17
- To Computer 10
- Connection Ports
 - 12 Volt DC relay output 9
 - Audio input connector 9
 - Audio output connector 9
 - BNC connector 9
 - Component video input connector 9
 - HDMI connector 9

- IR receiver 9
- Kensington lock hole 9
- M1 signal in connector 9
- Power cord connector 9
- RJ45 network connector 9
- RS232 connector 9
- S-video input connector 9
- VGA input connector 9
- Video input connector 9
- Control Panel 23

D

- Dell
 - contacting 57

M

- Main Unit 8
 - Control panel 8
 - Elevator button 8
 - Focus ring 8
 - Lens 8
 - Remote control receiver 8
 - Zoom tab 8

O

- On-Screen Display
 - Audio Menu 30
 - Computer Source Menu 35
 - Factory Reset Menu 35
 - Image Settings Menu 28
 - Language Menu 33
 - Management Menu 31
 - Network Settings Menu 34
 - PIP Setting Menu 33
 - Video Source Menu 35

P

- Powering On/Off the Projector
 - Powering Off the Projector 19
 - Powering On the Projector 19

R

- Remote Control 25

S

- Specifications
 - Audio 52
 - Brightness 51
 - Color Wheel Speed 51
 - Compatibility Modes 55
 - Contrast Ratio 51
 - Dimensions 52
 - Displayable Color 51
 - Environmental 52
 - H. Frequency 51
 - I/O Connectors 52
 - Lamp 51
 - Light Valve 51
 - Networking Protocol 52
 - Noise Level 52
 - Number of Pixels 51
 - PIP combination sources 54
 - Power Consumption 52
 - Power Supply 51
 - Projection Distance 51
 - Projection Lens 51
 - Projection Screen Size 51
 - Regulatory 52
 - RS232 Protocol 53
 - Uniformity 51

- V. Frequency 51
- Video Compatibility 51
- Weight 52
- support
 - contacting Dell 57

T

- Troubleshooting 45
 - contact Dell 45
 - Self-diagnostic 48

Federal Communication Commission Interference Statement

This equipment has been tested and found to comply with the limits for a Class B digital device, pursuant to Part 15 of the FCC Rules. These limits are designed to provide reasonable protection against harmful interference in a residential installation. This equipment generates, uses and can radiate radio frequency energy and, if not installed and used in accordance with the instructions, may cause harmful interference to radio communications. However, there is no guarantee that interference will not occur in a particular installation. If this equipment does cause harmful interference to radio or television reception, which can be determined by turning the equipment off and on, the user is encouraged to try to correct the interference by one of the following measures:

- Reorient or relocate the receiving antenna.
- Increase the separation between the equipment and receiver.
- Connect the equipment into an outlet on a circuit different from that to which the receiver is connected.
- Consult the dealer or an experienced radio/TV technician for help.

This device complies with Part 15 of the FCC Rules. Operation is subject to the following two conditions: (1) This device may not cause harmful interference, and (2) this device must accept any interference received, including interference that may cause undesired operation.

FCC Caution: Any changes or modifications not expressly approved by the party responsible for compliance could void the user's authority to operate this equipment.

IMPORTANT NOTE:

FCC Radiation Exposure Statement:

This equipment complies with FCC radiation exposure limits set forth for an uncontrolled environment. This equipment should be installed and operated with minimum distance 20cm between the radiator & your body.

This transmitter must not be co-located or operating in conjunction with any other antenna or transmitter.

Coretronic Corporation declared that 5100MP is limited in CH1~78 from 2402 to 2479 MHz by specified firmware controlled in USA.