

MobileAccess1000 DAS System Installation and Configuration Guide

**P/N: 709C001504
REV: A0
Date: AUG, 2012**

Corning MobileAccess
8391 Old Courthouse Road, Suite 300, Vienna, VA 22182
Tel: +1(866)436-9266, +1(703)848-0200 TAC: +1(800)787-1266, Fax: +1(703)848-0280
www.corning.com/mobileaccess

Preface Material

Installation Safety

- Follow all safety regulations when installing the MA1000 system
- Only qualified personnel are authorized to install and maintain the MA1000 system
- The equipment is intended for installation in restricted access locations only

RF Safety

To comply with FCC RF exposure compliance requirement, adhere to the following warnings:

Warning! To comply with FCC RF exposure compliance requirements, antennas used for this product must be fixed mounted on indoor permanent structures, providing a separation distance of at least 40 cm from all persons during normal operation.

Warning! Antenna gain should not exceed 12.5 dBi.

Warning! Each individual antenna used for this transmitter must be installed to provide a minimum separation distance of 40 cm or more from all persons and must not be co-located with any other antenna for meeting RF exposure requirements.

Warning! The design of the antenna installation needs to be implemented in such a way so as to ensure RF radiation safety levels and non-environmental pollution during operation.

Caution! Use of controls or adjustments or performance of procedures other than those specified herein may result in hazardous radiation exposure.

Compliance with RF Safety Requirements

- Corning MobileAccess products have no inherent significant RF radiation
- The RF level on the down link is very low at the Remote Hub Unit (RHU) downlink ports. Therefore, there is no dangerous RF radiation when the antenna is not connected.

Laser Safety

- Fiber optic ports of the MA1000/2000 emit invisible laser radiation at the 1310 nm wavelength window.
- To avoid eye injury never look directly into the optical ports, patchcords or optical cables. Do not stare into beam or view directly with optical instruments. Always assume that optical outputs are on.
- Only technicians familiar with fiber optic safety practices and procedures should perform optical fiber connections and disconnections of the MA1000/2000 modules and the associated cables.
- MA1000/2000 complies with 21 CFR 1040.10 and 1040.11 except for deviations pursuant to laser notice no. 50 (July 26, 2001) & IEC 60825-1, amendment 2 (Jan. 2001).

Care of Fiber Optic Connectors

- Do not remove the protective covers on the fiber optic connectors until a connection is ready to be made. Do not leave connectors uncovered when not connected.
- The tip of the fiber optic connector should not come into contact with any object or dust.
- Refer to the cleaning procedure for information on the cleaning of the fiber tip.

Power Requirements for DC Inputs

Warning!

- Only use a special DC supply cable with four connectors
- Always keep DC IN connectors connected during the product operation
- Disconnect all power from the equipment by means of an external circuit breaker before connecting or disconnecting the DC IN connectors.

Standards and Certification

Corning MobileAccess products have met the approvals of the following certifying organizations:

Product Certifications

US FCC 47 CFR part 15B, 22, 24, 90,27

NOTE: This equipment has been tested and found to comply with the limits for a Class A digital device, pursuant to Part 15 of the FCC Rules. These limits are designed to provide reasonable protection against harmful interference in a residential installation. This equipment generates, uses and can radiate radio frequency energy and, if not installed and used in accordance with the instructions, may cause harmful interference to radio or television reception, which can be determined by turning the equipment off and on, the user is encouraged to try to correct the interference by one or more of the following measures:

- Reorient or relocate the receiving antenna.
- Increase the separation between the equipment and receiver.
- Connect the equipment into an outlet on a circuit different from that to which the receiver is connected.
- Consult the dealer or an experienced radio/TV technician for help.

Warning!

Changes or modifications to this equipment not expressly approved by Mobile Access could void the user's authority to operate the equipment.

UL 60950-1

21CFR 1040.10 & 1040.11.

Europe EN 301502, EN 300609, EN 301489, EN 60950-1, IEC 60825-1, IEC 60825-2

Company Certification

ISO 9001: 2000 and ISO 13485: 2003

About this Guide and Other Relevant Documentation

This user guide describes how to perform the physical installation of the MA 1000 system. The installation procedures of other units (RIU, 860 WLAN solution) relevant to the system are detailed in their user manuals (see *Additional Relevant Documentation* below).

Additional Relevant Documents

The following documents are required if the corresponding units are included in your system installation.

P/N	Description
709C001503	1000 Installation and Configuration Guide
709C001205	2000 Installation and Configuration Guide
709C002502	RIU Installation and Configuration Guide
709C003003	330 Installation and Configuration Guide
709C001309	410/430 Installation and Configuration Guide
709C004401	SC-450 Installation and Configuration Guide

List of Acronyms

AGC	Automatic Gain Control
BDA	Bi-Directional Amplifier
BTS	Base Transceiver Station
BTSC	Base Transceiver Station Conditioner
BU	Base Unit
DL	Downlink
RHU	Remote Hub Unit
RIU	Radio Interface Unit
SNR	Signal to Noise Ratio
UL	Uplink
VDC	Volts Direct Current

Table of Contents

Preface Material	III
Installation Safety	III
RF Safety	III
Compliance with RF Safety Requirements	III
Laser Safety	III
Care of Fiber Optic Connectors	IV
Power Requirements for DC Inputs	IV
Standards and Certification	V
Product Certifications	V
Company Certification	V
About this Guide and Other Relevant Documentation	VI
Additional Relevant Documents	VI
List of Acronyms	VI
Table of Contents	VII
1 Introduction to MA1000 System	1
1.1 About MA1000	1
1.1.1 Features	1
1.2 System Architecture	1
1.3 Configuration Options	3
1.4 Management	4
2 System Elements	5
2.1 Remote Modules	5
2.1.1 MA1000 RHUs	5
2.1.1.1 1000 RHU Front Panel	6
2.1.1.2 MA1000 RHU Rear Panel	7
2.1.2 Add-on	7
2.1.2.1 Add-on Front Panel	8
2.1.2.2 Add-on Rear Panel	8
2.2 Base Units	9
2.2.1.1 BU Front Panel	10
2.2.1.2 BU Rear Panel	11
3 Site Preparation	12
3.1 Infrastructure Preparation	12
3.2 Installation Requirements	12
3.3 Coaxial Cable Connections	12
3.3.1 General Cable Installation Procedures	12
3.3.2 Fiber Optic Rules	13

3.3.3 RF Rules	14
3.4 Power Consumption, Connections and Power Supplies	14
3.4.1 Power Safety Instructions	14
3.4.2 Power Consumption of Units	15
3.4.3 Circuit Breakers	15
3.4.4 Types of Power Supplies	15
3.5 Installation Conventions	15
4 System Installation	17
4.1 Overview	17
4.2 Communication Room Installation	17
4.2.1 Rack Installation General Instructions	18
4.2.2 Rack Installation Safety Instructions	19
4.2.3 Single Building Rack Installation	19
4.2.4 Multi-Building Rack Installation	20
4.2.5 RIU Connections	21
4.2.6 BU Connections	21
4.2.7 Controller Connections	21
4.3 Remote Site Installation	22
4.3.1 MA1000 RHU Installation	22
4.3.1.1 Wall Mount	23
4.3.1.2 Connections	23
4.3.2 Add-on Installation	24
4.3.2.1 Assembly and Connections	25
4.3.3 860 WLAN Solution Installations	26
4.3.4 Antenna Connections	26
Appendix A: System Specifications	27
RF Frequency Ranges	27
RF Parameters per Service	28
Low Band Services	28
High Band Services	29
Absolute Maximum Rating	29
Optical Specifications	30
Multimode Fiber Qualifications	30
Environmental	30
MA1000 Component Specifications	31
Base Unit	31
RHU 31	
Add-On	32
Ordering Information	33
MA1000 QSX	33

MA1000 TSX.....	33
Base Units	33
Remote Hub Unit Modules	34
Add-On Modules	34
Power Supply Accessories.....	35
Mounting Bracket Accessories.....	35

1 Introduction to MA1000 System

1.1 About MA1000

The **MA1000** provides enterprise level indoor coverage for a wide range of wireless services over a single broadband infrastructure.

The MA1000 is a single operator, multi-band system based on combining a number of services, voice and data, and distributing them to each remote location through a common antenna infrastructure. These include Cellular, Paging, Public Safety and LTE SISO signals.

Cellular services are bi-directionally transferred between the capacity source (BTS/BDA) and the remote locations using low loss fiber and broadband coax.

WLAN services from Wi-Fi Access Points (802.11 a/b/g/n) can be integrated with the MA1000 system at the remote sites for transport over a single cabling infrastructure to the antenna.

1.1.1 Features

- A multi-service platform that accommodates the combination of cellular and enterprise services (e.g. WLAN, WMTS Telemetry and 900MHz Building Automation), eliminating the need for separate overlay networks
- Carrier Class QoS – advanced signal handling and management ensures optimal performance for all services
- Local and remote end-to-end monitoring and control through an interface to 410, 430 or SC-450 system controller
- Low power system requirements eliminates the need for a high power capacity source's, reducing operator expenses
- Comprehensive conditioning and monitoring of RF signals at the head-end through an interface to the Radio Interface Unit (RIU)
- Reduce cost through the support of multimode fiber
- Software programmable parameters including output power, AGC (on/off and levels), and system gain
- Real time component setting capabilities for optimal performance

1.2 System Architecture

The MA1000 solution is based on the following main elements:

- **Base Units (BUs)** – The BUs perform RF to optic conversion on the BTS side.
- **MA Remote Hub Units (RHUs) 1000** – The MA 1000 performs the RF to optic signal conversion at the antenna side for up to two services corresponding to the RHU model. A third service can be added by connecting an add-on remote hub unit to the MA1000 RHU.
- **Add On** – Service specific module that provides support for an additional service to an **existing RHU**.
- **700 LTE SISO add-on** – Add-on module specifically designed to support LTE SISO in the 700 MHz lower A, B and C blocks and the upper C block. (The LTE add-on model varies depending on whether or not it is used in conjunction with the 700/800 Public Safety RHU).

- **860 WLAN Solution** – The 860 and WCE is a wireless LAN module that provides secure and centralized connections for 802.11a/b/g Access Points and distributes the wireless services over the same coax and broadband infrastructure as the voice services.

All services are combined and distributed through the same antenna broadband infrastructure.

To provide optimum coverage at all times and monitoring and control of all system elements from a central location MA provides the following devices:

- **Radio Interface Units (RIUs)** – The RIUs provide interfaces for up to three BTS/BDA signals, and automatically adjusts the output signal in response to input signal level in order to provide optimal coverage.
- **410, 430 and SC-450 controllers** – The controllers enable remote monitoring of the system elements from a *single location* via advanced intuitive GUI.

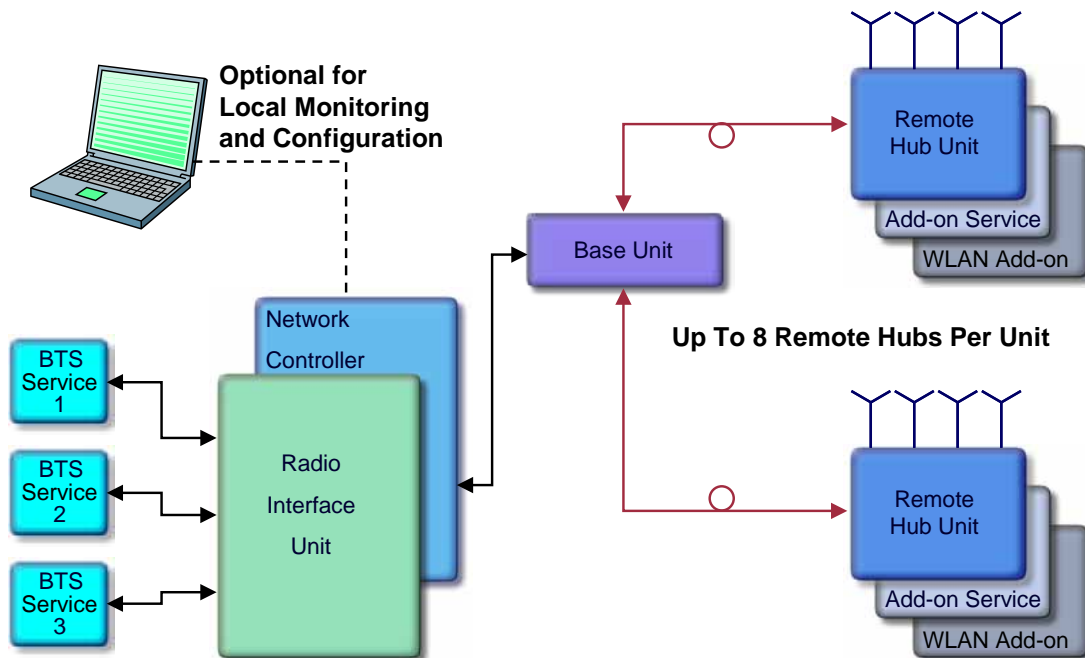

Figure 1. MA1000 System Overview

1.3 Configuration Options

The MA1000/Add-on system includes three basic configuration options:

A) Basic configuration

The Base Unit drives a single or dual band, MA 1000 RHU. The dual band RHU consists of a low band service (cellular 800, iDEN, Paging, or GSM 900) and a high band service (PCS 1900 or DCS 1800).

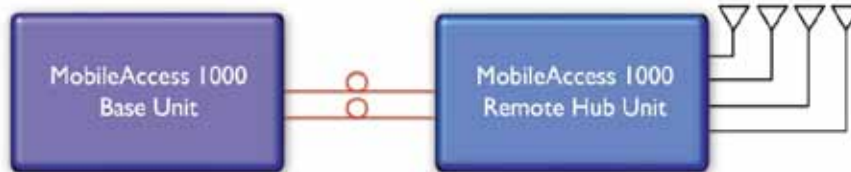

Figure 2. MA1000 Basic BU – RHU Configuration

B) Using the Add-on unit to provide an additional service

An Add-on unit can be connected to an MA1000/2000 RHU to provide a third service. The add-on unit can be PCS, UMTS, AWS, LTE700 MHZ or any future service.

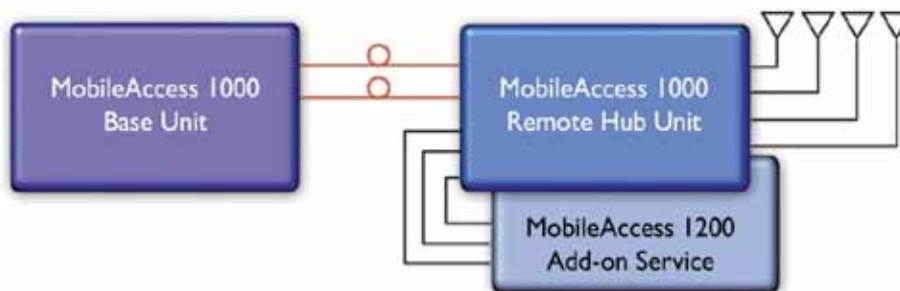

Figure 3. MA1000 BU and RHU Plus Add-On

C) Using the 860 WLAN solution to provide access to high data-rate service

An 860 WLAN solution may also be added in a configuration that includes both MA1000 RHU and Add-on RHU or only MA1000 RHU.

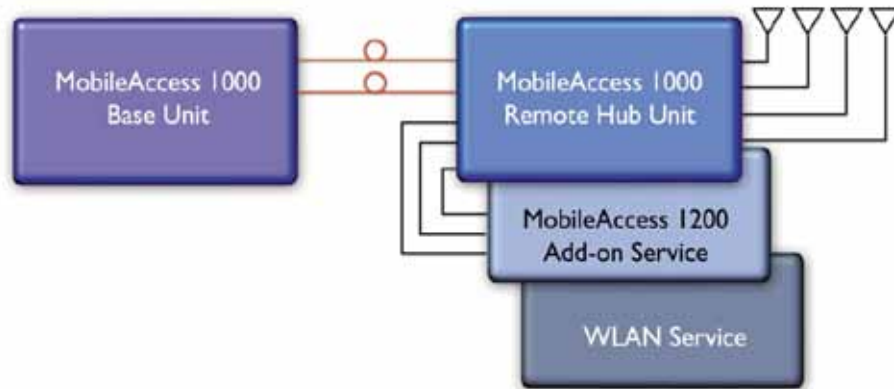

Figure 4. BU and RHU Plus Add-on Plus WLAN Configuration

1.4 Management

The Corning MobileAccess family of Element Management System (EMS) Controllers provide complete site coverage and management of the MA 1000 system. They can be used to provision coverage that can compensate for changing loads. They also provide real-time monitoring, control and diagnostics capabilities for *Corning MobileAccess* devices from a single location.

- 410 – enables management of the 1000/2000 system components through a local RS-232 or dial-up connection. It is also used as a slave controller to a 410, 430 or SC-450 controller to expand the management system on a site. Management access is provided through the MCT GUI application.
- 430 – enables management of the 1000/2000 system components through a local RS-232 or dial-up connection. Management access is provided through the MCT GUI application or via the NMS Server Software Application which communicates via SNMP over a Ethernet TCP/IP connection. The 430 may also be monitored via a 3rd party SNMP application for receipt of SNMP traps.
- SC-450 - enables management of the 1000/2000 system devices through local or remote Ethernet TCP/IP connection. Management access is provided through a local and remotely accessible web-GUI interface. The SC-450 may also be monitored via a third party SNMP application for receipt of SNMP traps.
- **MCT** – a Java based GUI application provided with both controllers. MCT is used with the 410 and 430 after the installation procedure to adjust Corning MOBILEACCESS devices according to the installation site characteristics in order to optimize coverage for the site.

The application is installed and run from a computer that is connected either locally or via remote dial-up modem to the 410 or 430 at the site.

- **MobileAccess Manager™** – a Java based GUI software application that provides enhanced monitoring and control capabilities for all your *1000/2000* sites from a single location. The **MobileAccess Manager** application is not supplied with the controller – it is *purchased separately*.

2 System Elements

This chapter describes the MA1000 system basic elements: remote modules (1000 RHU and Add-on) and the Base Units. Your system may include additional elements such as 410, 430 and SC-450 controllers, RIUs and 860 WLAN solution units; these are described in the corresponding User Guides.

2.1 Remote Modules

The Optical to RF conversion of each service at the individual building floors is performed by remote units corresponding to the service types. These consist of 1000 RHUs and in addition, may include Add-on modules and 860 WLAN solution modules.

The configurations depend on the requirements of the site and the supported services. The following sections describe each of the system elements.

NOTE: The connections as they relate to the MA 1000 system are described in Chapter 4 - System Installation.

2.1.1 MA1000 RHUs

Each RHU supports two different services (one high-band and one low-band). All RHUs are add-on ready, meaning that their optic interface and control functionality can support a third (high-power) service through the connections of an Add-on module (see section 4.3.2.1).

Each 1000 RHU is connected to the corresponding BU (located in the communication room) through a fiber optic connection. Remote monitoring is provided through the BU connections to the 410, 430 and SC-450 controller (1.4).

The 1000 RHU services, add-on service and data services (provided by 860 WLAN system) at each location are combined and then transmitted over a common infrastructure to strategically placed antennas.

2.1.1.1 1000 RHU Front Panel

The 1000 RHU front panel contains the fiber optic connections to the BU, four coax connections to the antennas, power connections and status indicators.

If 1000 RHU and Add-on units are installed, then the combined services are fed to the coax infrastructure through the *1000 RHU antenna ports*. However, if 860 WLAN solution is also installed, the combined *data and voice* services are fed to the coax infrastructure through the *860 antenna ports*.

NOTE: To provide alarms, the antenna must supply a DC resistance of up to 5K ohms.



Figure 5. 1000 RHU Front Panel

Table 2-1. 1000 RHU Front Panel Indicators

LED	Description
COMM	Active communication detected
LINK	Optical link to BU detected
PWR	DC power connected

2.1.1.2 MA1000 RHU Rear Panel

The MA1000 RHU rear-panel provides the control, RF interface and optic interface ports that enable connecting an Add-on unit to the 1000 RHU module.



Figure 6. MA1000 RHU Rear

Table 2-2. MA1000 RHU Rear Panel Connectors

Add-on control	Transmits the control signals from Add-on module to the 1000 RHU module. Connected to the Add-on Control From port.
High Band	Connects to the Add-on High Band port. Provides the interface to the Add-on RF service which is combined with the RHU services and distributed through the common coax infrastructure.
Low Band	Connects to the Add-on Low Band port. Provides the interface to the Add-on RF service which is combined with the RHU services and distributed through the common coax infrastructure.
DL, UL	Transmit the RF signals to- and from- the Add-on module. These ports are connected to the corresponding ports on the ADD-ON rear panel: DL to DL, UL to UL.

2.1.2 Add-on

The Corning MOBILEACCESS Add-on module is a high power module, supporting a single frequency band (low or high). It is designed to be integrated with a host *1000 RHU* module. The 1000 RHU module provides the following functionality for both units:

- Optical interface (to the BU) and conversion
- RF interface (to antennas) and conversion
- Control signals

In addition, WLAN services can also be combined with Add-on and 1000 RHU services. (However, in this type of configuration the combined services interface to the coax infrastructure through the 860 ports.)

NOTE: The units are integrated through simple external cable connections between corresponding ports.

2.1.2.1 Add-on Front Panel

The RHU Add-on front panel contains the power connection and status LEDs. (The RS-232 connector is reserved for MA service personnel).

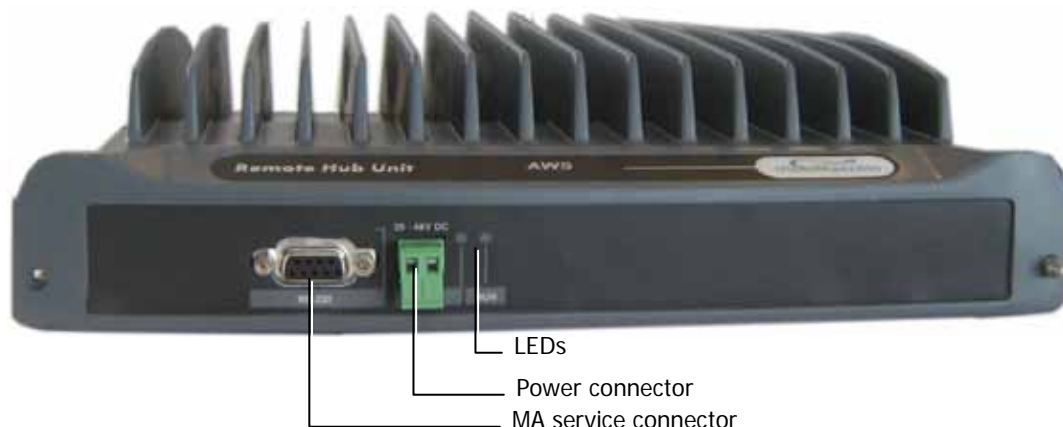

Figure 7. RHU Add-on Front panels

Table 2-3. Corning MOBILEACCESS Add-on Front Panel Indicators

LED	Description
RUN	When blinking, indicates that the RHU is in normal operating mode.
PWR	Power ON

2.1.2.2 Add-on Rear Panel

The RHU Add-on rear panel contains the connections to the 1000 RHU and 860.

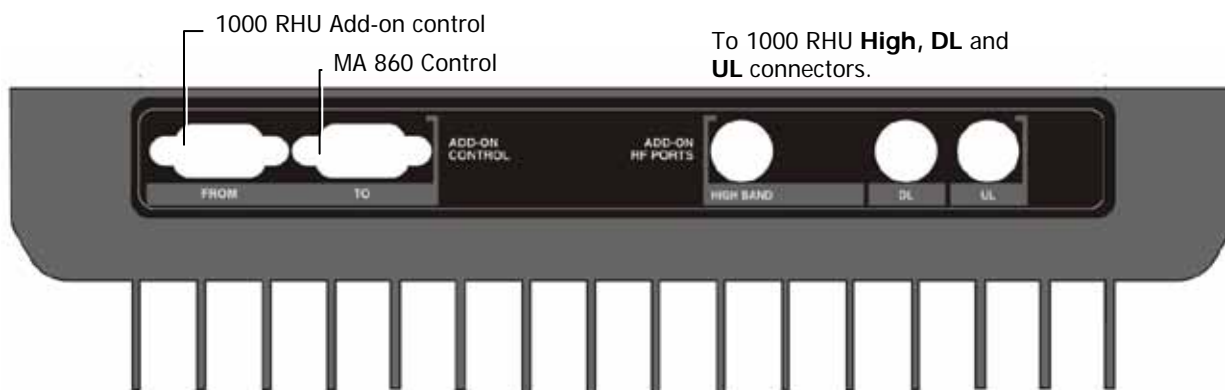

Figure 8. RHU Add-on Rear Panel

Table 2-4. RHU Add-on Rear Panel Connectors

Add-on Control	Transmits the control signals between the Add-on module and the 860 and 1000 RHU modules: <ul style="list-style-type: none"> From – receives control signals from the 1000 RHU. Connected to the 1000 RHU Add-on Control connector. To – for configurations that include 860. Transmits control signals to 860. Connected to the 860 Add-on Control connector.
DL, UL	Transmit the RF signals to- and from- the Add-on module. These ports are connected to the corresponding ports on the 1000 rear panel: DL to DL, UL to UL.
High	RF service output port connected to the 1000 RHU rear-panel High port.

2.2 Base Units

The BUs (Base Units) perform RF to optical conversion of the signal on the BTS/BDA side. Each can support up to two services (provided by the same operator). Two models of BUs are available: four-port unit – supporting four RHUs, and eight-port unit supporting up to eight RHUs. The RHU models correspond to the services supplied through the BUs.

The BU (and all the corresponding remote units) may be remotely monitored and managed via the 410, 430 and SC-450.

The BUs are usually installed in the telecom room adjacent to the BTS/BDA signal source. RF ports on the rear panel provide interface to the BTS side (through connection to RIU or passive interface), while optic ports on the front panel provide interface to the RHUs (Remote Units). The following sections describe the BU front and rear panels, including indicators and connectors.

2.2.1.1 BU Front Panel

The front panel contains the optical connections and indicators. The BU is available in two configurations: Four-port - and Eight-port BUs. The eight-port BU consists of two four-port elements where each four-port element has a dedicated set of indicators (PWR, LSR and Link 1 to Link 4 or Link 5 to Link 8).

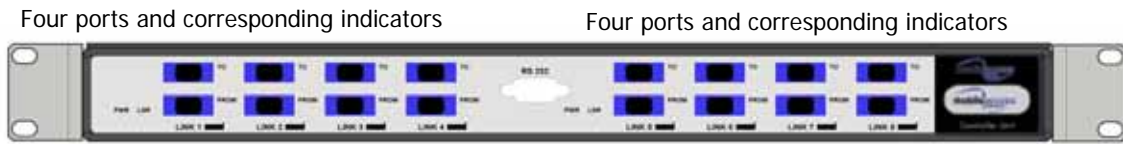

Figure 9. Eight-Port BU Front Panel



Figure 10. Four-Port BU Front Panel

Table 2-5. BU Front Panel Indicators

LED	Description
PWR	Power input detected for the corresponding unit.
LSR	ON - laser circuitry for the corresponding element (group of four ports) is functioning correctly.
Link 1-4, 5-8	ON - the optical link to/from the connected remote functions within the specifications in both directions. Blinking - optical power from remote is lower than expected by at least 2 dBm

2.2.1.2 BU Rear Panel

The BU rear panel contains the RF, NMS, and power connections. Note that there are two uplink and two downlink RF connections to the BTS side (to an Interface Box or RIU) - each individual uplink and downlink connection corresponds to a four-port BU element. For a four-port BU, one uplink and one downlink port is connected; for an eight-port BU, two uplink and two downlink ports are connected.



Figure 11. BU Rear Panel (RF Connections)

Table 2-6. BU Rear Panel Connections

Connector	Description
Uplink output	Uplink connectors to be connected on BTS side.
Downlink input	Downlink connectors to be connected on the BTS side.
Com Port RS485	Connection to 410, 430, SC-450 controller.
PWR	Power connection
Alarms	N/A

3 Site Preparation

3.1 Infrastructure Preparation

This following installation rules are based on the assumption that site survey and installation planning (*including power requirements*) have been completed.

3.2 Installation Requirements

The infrastructure preparation consists of two main phases:

- A. **Floor Planning:** Planning the distribution of the antennas on each floor to provide the required coverage.
- B. **Telecom Closet Planning:** Planning the layout of the devices and cables in the telecom closet or shaft. This includes the 860, 802.11 Access Points, cabling and other voice service distribution systems that are relevant to the specific installation.

3.3 Coaxial Cable Connections

3.3.1 General Cable Installation Procedures

Observe the general cable installation procedures that meet with the building codes in your area. The building code requires that all cabling be installed above ceiling level (where applicable). Each length of cable from the risers to each antenna must be concealed above ceiling.

The cable must be properly supported and maintained straight using tie-wraps, cable trays and clamps or hangers every 10 feet (where practical above ceiling level). Where this is not practical, the following should be observed:

- The minimum bending radius of the supplied ½" coax cable should be 7".
- Cable that is kinked or has a bending radius smaller than 7" must be replaced.
- Cable runs that span less than two floors should be secured to suitably located mechanical structures.
- The cables should be supported only from the building structure.

3.3.2 Fiber Optic Rules

- Either single mode or multimode fiber can be used with Corning MOBILEACCESS 1000M products, while Corning MOBILEACCESS 1000 products can only be used with single mode fiber.
- Only Multimode fiber, 50/125 or 62.5/125um complying with ANSI/TIA/EIA-568-B series, EN50173-1 or ISO/IEC 11801 can be used. The fiber length can be up to 300 meters assuming the following qualifications:
 - § All fiber in a given length of fiber must be of the same core diameter.
 - § All Bulkhead adapters must be Single mode SC/APC (Green) adapters.
 - § All terminations cross connections or patches must be direct fusion splice or Corning MOBILEACCESS specified patch cords listed below.

900 microns pathcord for splicing, 2 Meters, 2xSC/APC		
Diamond p/n ENC/1045341	Beige boots, 62.5/125/900	MA# 500001057
Diamond p/n ENC/1045340	Black boots, 50/125/900	MA# 500001058

Zipcord patchcord, 4xSC/APC, 50/125/900/2000/4500 micron		
Diamond p/n ENC/1045342	Black/Brown boots, 1Meter	MA# 50000105
Diamond p/n ENC/1045343	Black/Brown boots, 3 Meter	MA# 500001060

Zipcord patchcord, 4xSC/APC, 62.5/125/900/2000/4500 micron		
Diamond p/n ENC/1045344	Beige/Brown boots, 1 Meter	MA# 500001061
Diamond p/n ENC/1045345	Biege/Brown boots, 3 Meter	MA# 500001062

- **Use only 8-degree SC/APC connectors (green color).**
- Use **only** fusion splice for connecting two fibers.
- Use minimum splicing/connectors to achieve minimum losses on the fibers (<0.5dB).
- Use precaution while installing, bending, or connecting fiber optic cables.
- Use an optical power meter and OTDR for checking the fiber optic cables.
- Make sure the environment is **clean** while connecting/splicing fiber optic cables.
- All fiber optic connections should be cleaned prior to attaching to termination points using a dry cleaning device (i.e. Cletop or equivalent).
- Fiber connector protective caps should be installed on all non-terminated fibers and removed just before they are terminated.
- Verify the Fiber Optic connections using a suitable fiber optic test procedure.
- Pay special attention while connecting the SC/APC connectors - you must hear the "click" when the connection is made.

3.3.3 RF Rules

- Use coax ½", 50ohm, male-to-male N-type, (6-7dB for 1Ghz, 11dB for 2Ghz) for connecting to RHU and RHU ports.
- Use coax RG223, 50ohm, male-to-male N-type for RF connections from the BUs to the BTS/RBS and to the RIU.
- When using the Corning MOBILEACCESS system in an environment in which other indoor coverage systems are installed, it is recommended (where possible) that the antennas are placed at least two meters apart
- When bending coax cables, verify that the bending radius does not exceed the coax specifications.
- Use wideband antennas supporting a range of 800Mhz to 2500Mhz
- Use a VSWR meter (i.e. Site Master or equivalent) for checking coax cables, including the antennas. (<2). The VSWR must be measured prior to terminating the RHUs in the remote communication rooms
- Terminate all unused **RHU** and **RIU** ports with a 50 ohm load

3.4 Power Consumption, Connections and Power Supplies

3.4.1 Power Safety Instructions



SAFETY WARNINGS

- When installing or selecting the power supplies:
- Be sure to disconnect all power sources before servicing.
- Calculate the required power according to the requirements of the specific installation and then determine the configuration of the power supplies. The required DC cables will then be determined by the selected PS configuration.
- Use only **UL** approved power supplies
- **AC and DC power supply cables** – use only the power cords supplied with the units
- Install external over-current protective devices for the system according to the requirements described in section 3.4.3.

3.4.2 Power Consumption of Units

Table 3-1. Corning MOBILEACCESS™ Power Requirements

Unit Type	Voltage Input	Typical Power Consumption	Maximum Current Consumption
Remote Unit 1000	20 to 48VDC	25W	1.25A
Remote Unit 1000E	20 to 48 VDC	29W	1.45A
Add-on	25 to 48VDC	50W	2.0A
RIU – 3 BTSCs	20 to 48VDC	12W	0.6A
Base Unit	20 to 48VDC	14W	0.7A
410/430 Controller	20 to 48VDC	10W	0.5A
860	20 to 48VDC	20W	1.0A

3.4.3 Circuit Breakers

Install fuse protections for the system according to the following criteria:

- The following system elements require external fuse protection: **RIUs, BUs, 410, 430 and SC-450 Controllers.**
- Referring to Table 3-1, calculate the required fuse protection.
- **Example:** a set of three elements consisting of a BU, RIU and 410, 430 or SC-450 controller requires a 2A circuit breaker.

3.4.4 Types of Power Supplies

Corning MobileAccess supplies various power supplies that can be installed in a rack or mounted on a wall, depending on your configuration.

3.5 Installation Conventions

Some of the basic installation conventions are listed below for the 1000 system:

- **Base Units** – are usually concentrated in the same location, most often in the main communication room.
- **Remote Hub Units** usually placed in the communication shaft or closet of a corresponding floor so they can be easily located. Each RHU can typically cover a floor of up to 30,000 sq ft.
- **Fiber optic cable** - bundled fibers are terminated into the Base Units in the main communication room. The fibers are then routed to each coverage location where individual fibers terminate into splice boxes. The splice box couples the installed fiber into the remote units. Enough spare fibers should be installed to take into account future expansion of the system.

For example, for three remote units, six fibers are required. However, to allow for future upgrades, it is recommended to install additional optic fibers to be connected to additional RHUs.

The following figure illustrates fiber optic routing sufficient to cover 21 floors: each group of strands can cover three floors as illustrated below, with two strands to spare. The first group

of strands covers floors 1, 2 and 3; the next group will cover floors 4, 5 and 6 through an additional splice box.

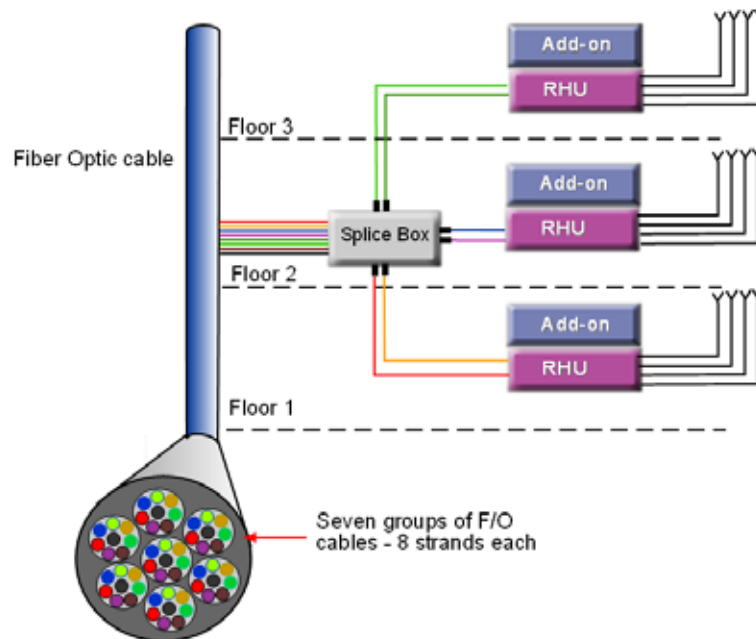

Figure 12. Illustration of Fiber Optic Routing

- **For remote power supply configuration** - cable bundles are routed from the main communication room and individual wire pairs are terminated into the power feed of individual units.

By providing power from a single distribution point, maintenance can be reduced and UPS backup can be easily provided. The maximum distance from the source to the termination spot is 1000 feet using 18 gauge wires.

In many locations local codes do not require power to be run through conduit if 100 watts or less is used. Please consult the regulations in your local jurisdiction prior to deploying remote power. When power cables require distances greater than 1000 feet 14 or 16 gauge wire may be used.

- **On each floor** - the antennas are connected to the RHUs using coax cables.

4 System Installation

4.1 Overview

This chapter describes how the communication room and remote locations are installed. The individual system elements are described in Chapter 2. In order to describe the installation process clearly, it will be described as consisting of two logical parts:

- A. **Telecommunications room** – installing the **RIUs, BUs, 410, 430 and SC-450 controllers**, and the required *passive equipment* in the telecommunication room close to the RF signal source. This installation may differ between single and multi-building topologies.
- B. **Remote locations** – **RHU** and **Add-on** installations and connections. These are *usually* wall mounts.

The installations for two basic topologies are described in detail: for single building and for multi-building. By understanding the two generic installations you will be able to address any variations in system deployment.

4.2 Communication Room Installation

It is recommended to install the following Corning MOBILEACCESS system modules in a 19" rack in the communication room

- RIU 3U
- BU 1U
- 410, 430 and SC-450 controller 1U
- Fiber Optic patch panel and splice tray
- Power supply/supplies

4.2.1 Rack Installation General Instructions

Verify that the rack height can support all the units to be installed, where you may also want to consider future expansions.

Figure 13 shows the recommended physical location of the Corning MOBILEACCESS elements in the rack in order to facilitate and simplify the cabling *connections*. The configuration is for a single operator. If the site is serviced by more than one operator, each operator often installs their equipment in a separate rack.

NOTE: Note that the **410, 430 SC-450 Controller** is at eye level to provide an easy view of the LED indicators and LCD display and easy access to the local and remote monitoring connections.

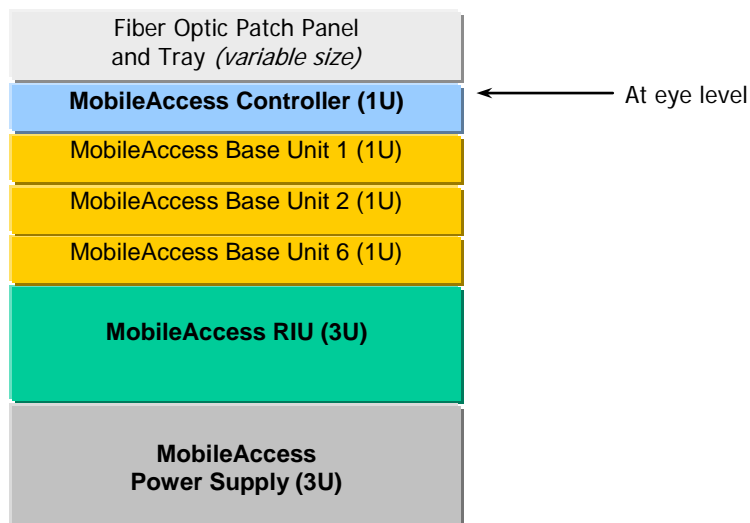

Figure 13: Recommended Order in the Communication Room Rack

4.2.2 Rack Installation Safety Instructions

Review the following guidelines to help ensure your safety and protect the equipment from damage during the installation.

- Only trained and qualified personnel should be allowed to install or replace this equipment.
- Verify that ambient temperature of the environment does not exceed 50°C (122°F)
- To maintain a low center of gravity, ensure that heavier equipment is installed near the bottom of the rack and load the rack from the bottom to the top.
- Ensure that adequate airflow and ventilation within the rack and around the installed components so that the safety of the equipment is not compromised. It is recommended to allow for at least about 2 cm of airspace between devices in the rack.
- Verify that the equipment is grounded as required – especially the supply connections.

4.2.3 Single Building Rack Installation

This section provides an example of a single building **main communication room** installation for a 24-floor building with Cellular and PCS coverage.

Since there are 24 floors, then 24 RHUs are required – one for each floor. In addition, the following equipment will be installed in the main communication room:

- Three BUs – to support 24 RHUS
- One 430 controller for monitoring
- One RIU with Cellular and PCS BTSCs – to interface to the BTS/BDA

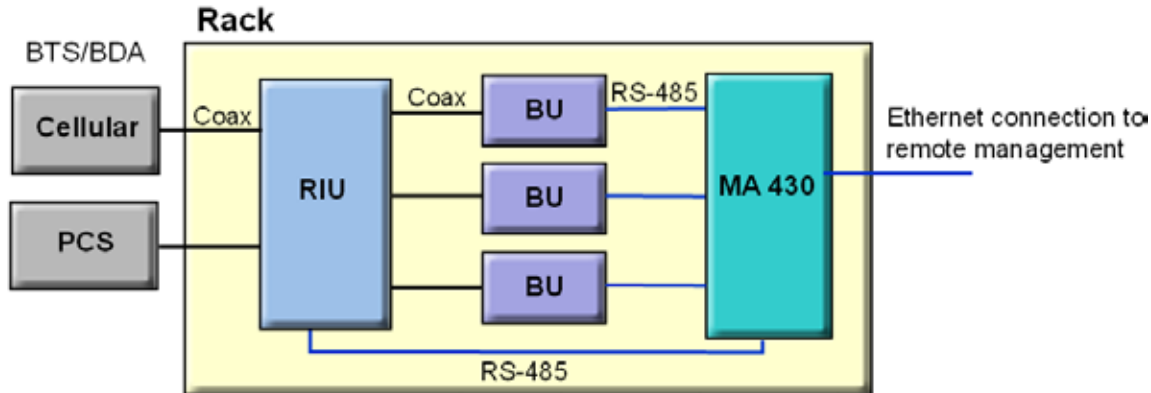

Figure 14. Example of Single-building Topology Communication Room Installation

4.2.4 Multi-Building Rack Installation

The figure below provides an example of a multi-building solution which distributes two bands from a main site over two remote sites up to 20Km away. **The 330** units extend the RF signal from the Main to the Remote buildings over a single strand of fiber. Uplink and downlink signal are placed on the single fiber at 1310 and 1550 respectively.

The 330 system provides flexible solutions for various site requirements. The figure below illustrates two types of installations:

- **Remote Building 1** – installation in a remote location with several Base Units. For clarity, the example shows two Base Units. However, the configuration applies to a maximum of four (8-port) Base Units that are supported using a 330 Expansion Box.

The 330 Remote unit forwards the signals as follows:

- Service signals to the Base Units
- Control signals from Master Controller at the main site to the 410 Slave Controller at the remote site. The Base Units are controlled through the 410 controller.
- **Building 2** – special installations in a remote location with *a single* Base Unit. The 330 Remote unit forwards both the service and the control signals from the main building *directly* to the Base Units. Note that a *410 Controller is not required in this type of installation*.

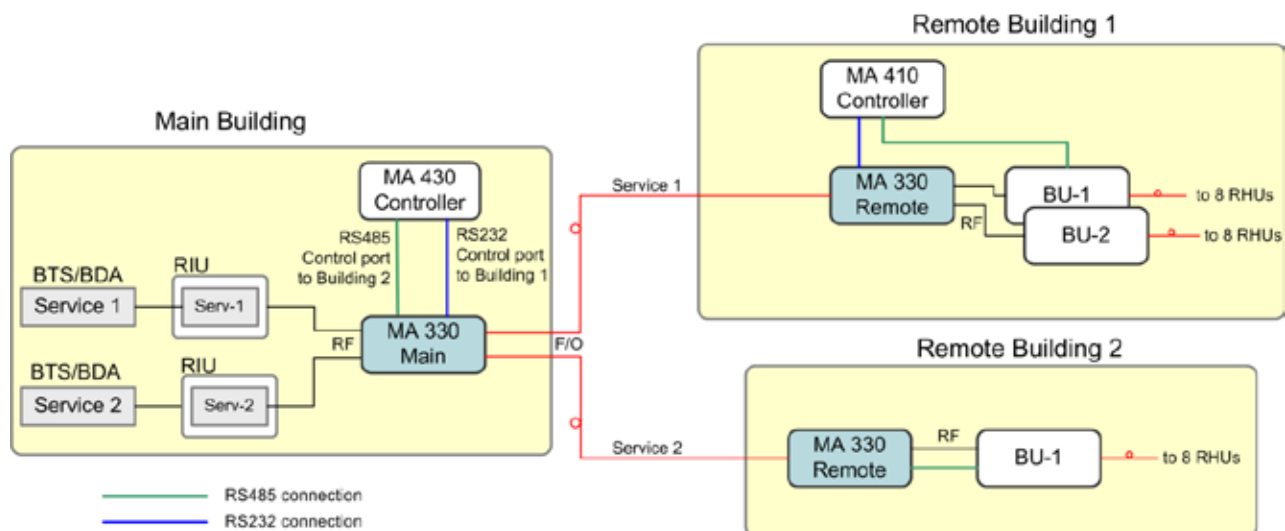

Figure 15: 330 System Installation Examples

4.2.5 RIU Connections

Refer to the RIU Products Installation and Configuration Guide for detailed instructions on connecting the RIU model in your installation.

4.2.6 BU Connections

NOTE: It is assumed that the patch panel cabinet (SC/APC adaptors) for fiber optic cable connections is installed in the rack near the BUs.

1. Connect (3/125/900) pigtail with SC/APC connectors between **splice tray** and **patch panel** cabinet.
2. Connect (3/125/3000) SC/APC jumpers between the corresponding **BU** and **patch panel**.
3. Connect the fiber optic cables from the **BU** to the **RHUs** through the patch panel cabinet.
4. Connect the **UL RF** Output and **DL RF** Input connectors to the RIU or UL and DL connectors or to the passive interface (such as Interface Box) in topologies that do not include RIUs.

4.2.7 Controller Connections

Refer to the *NMS 410/430 or SC-450 Installation and Configuration Guide* for connections.

4.3 Remote Site Installation

4.3.1 MA1000 RHU Installation

Mount and install each RHU on the wall in the communication shaft or communication room.

The following provides the dimensions for the RHU unit.

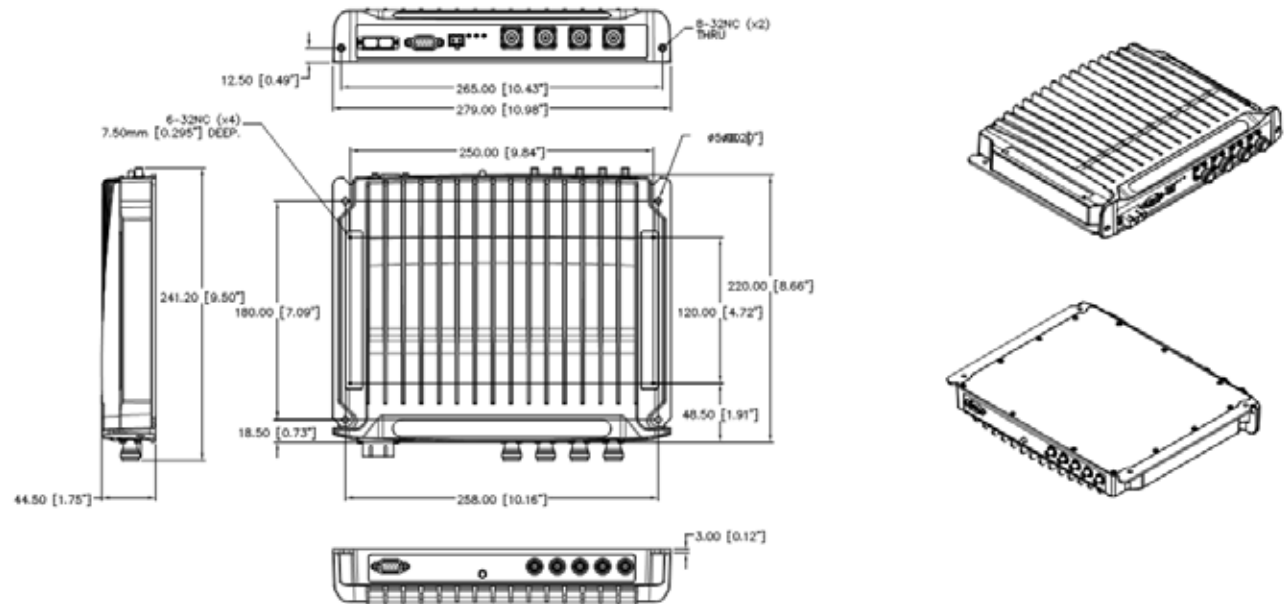

Figure 16: MA1000 RHU Dimensions

4.3.1.1 Wall Mount

MA1000 RHU is usually mounted on a wall in a clean indoor environment – **RF ports facing down**.

Assembly instructions

1. Place the unit against the wall and mark the four holes to be drilled in the wall.
2. Drill four holes 8mm in diameter and insert the appropriate sized plastic plugs in each hole.
3. Secure the MA1000 RHU to the wall using four screws, 4.5mm diameter, 40mm long.

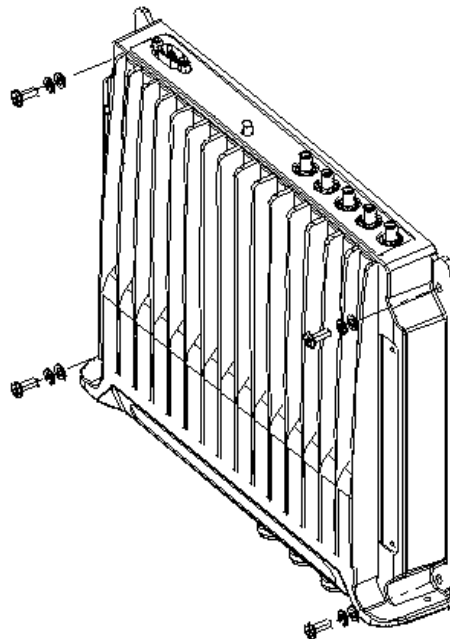

Figure 17. MA1000 RHU Wall Mount

4.3.1.2 Connections

NOTE: Keep in mind the rules for handling and connecting F/O cables. The F/O cables will be connected to the associated BU in the communication room at a later phase.

1. Connect fiber optic cable to splice box and to SC/APC pigtails to RHU.
2. For the **downlink**, connect the fiber optic cable pigtails from splice box coming from the **BU** port to the corresponding **RHU** port.
3. Connect the **RHU** to **antennas** according to the RF engineers design (up to 4 antennas per RHU).
4. For the **uplink**, connect the fiber optic cable pigtails from splice box from the **RHU** to the **uplink port** that connects to the **BU**.
5. Connect the **power** to each RHU according to power design planning.
6. Verify that 50 ohm terminators are placed on the unused uplink and downlink connectors.

4.3.2 Add-on Installation

The following figure provides the dimensions for the Add-On unit.

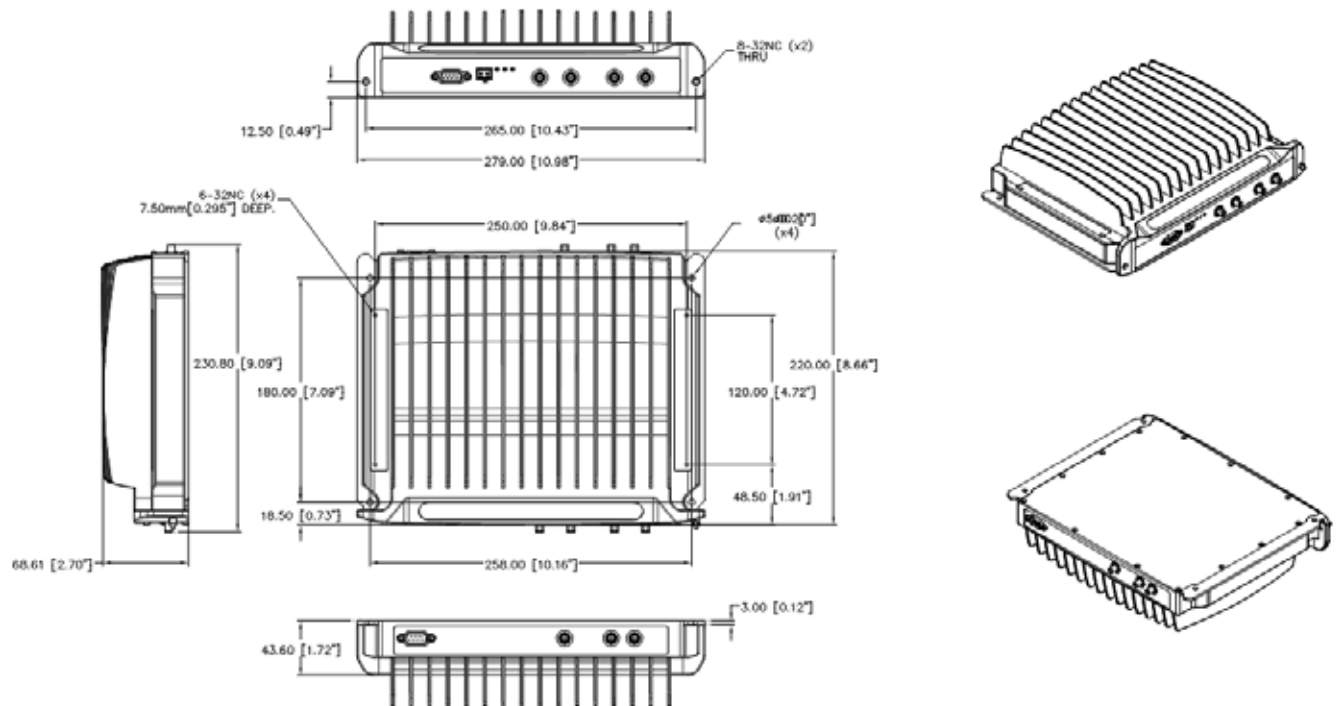

Figure 18. Add-On Dimensions

4.3.2.1 Assembly and Connections

Refer to Figure 19.

ATTENTION!

To prevent damaging the SMA connectors, be sure to tighten using a torque of 8lb.

1. Position the supplied bracket on the 1000 RHU and secure the **bracket** to the **1000 RHU** using the four supplied **6-32 NC** screws.
2. Position the RHU Add-on unit on the bracket and secure the **Add-on** to the **bracket** using the four supplied **8-32** screws.
3. **Interconnect** the 1000 RHU and RHU Add-on SMA **Uplink**, **Downlink** and **High** connectors on the rear panels of both units using the **three straight** jumpers.
4. **Interconnect** the 1000 RHU and RHU Add-on **D-type 9-pin** connectors on the rear panels of both units using the supplied flat-cable.
5. Connect the power to the RHU Add-on front-panel **DC** connector.6.

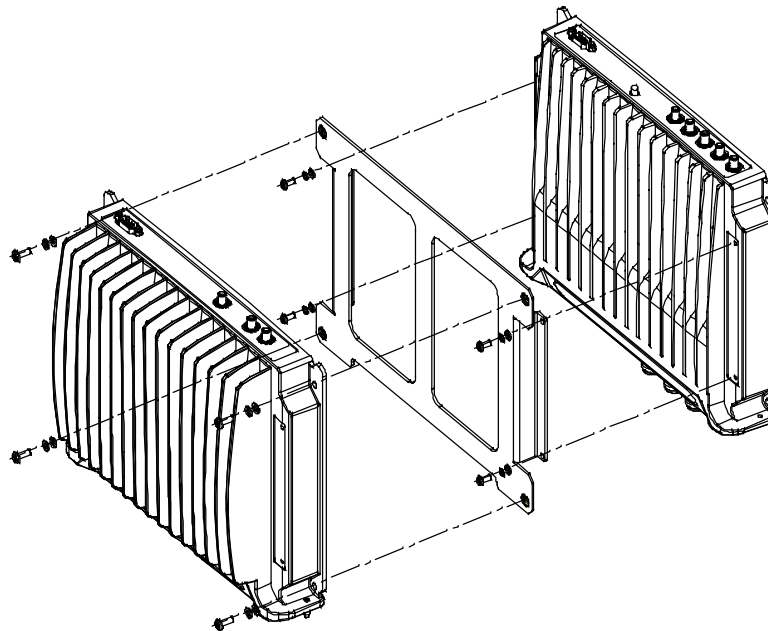

Figure 19. RHU Add-on to 1000 RHU Assembly

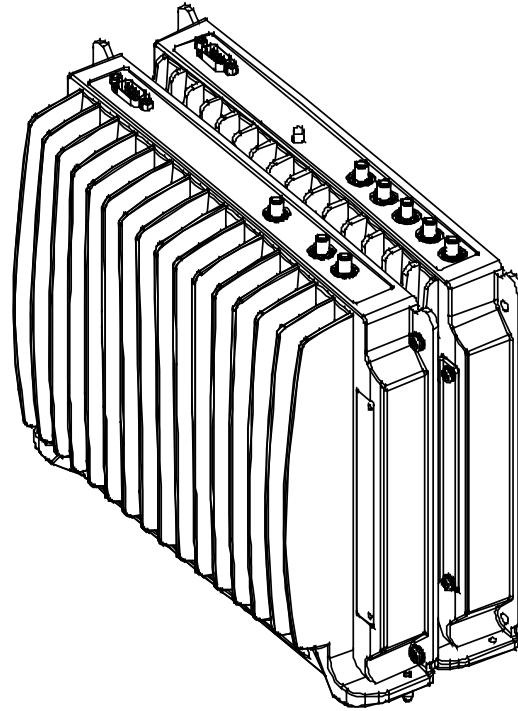

Figure 20. RHU Add-on to 1000 RHU Completed Assembly

4.3.3 860 WLAN Solution Installations

Refer to the corresponding User Manual for detailed instructions on installing the unit.

4.3.4 Antenna Connections

- For systems *without* the 860 WLAN solution modules - connect the antenna connections to the RHU antenna ports;
- For systems with the 860 WLAN solution - refer to the *860 Installation and Configuration Guide* and connect the antenna ports to the 860.

Appendix A: System Specifications

RF Frequency Ranges

Band	Uplink	Downlink
Low Band Services		
LTE SISO*	698-716 777-787MHz	728-757MHz
CELL	824-849	869-894
Telstra 850M	824-849	869-890
iDEN (SMR800)	806-824	851-869
GSM	890-915	935-960
E-GSM	880-915	925-960
iDEN SMR900/Paging	896-902	929-941
High Band Services		
DCS	1710-1785	1805-1880
PCS	1850-1910	1930-1990
G-PCS	1850-1915	1930-1995
UMTS	1920-1980	2110-2170
AWS	1710-1755	2110-2155

*700 LTE Lower A, B, C blocks 3GPP Band 13 and Upper C blocks

RF Parameters per Service

Low Band Services

MA1000 RF Parameters - Low Band Services										
RF Parameter	LTE 700 MHz		CELL TDMA / CDMA / WCDMA / GSM800		SMR 800 ⁶		GSM / E-GSM		SMR 900 ⁶	
	DL	UL	DL	UL	DL	UL	DL	UL	DL	UL
Max Output Power / Antenna Port										
1 (Composite)	21		20		20		14		20	
2 Carriers	18		17		17		11		17	
4 Carriers	15		14		14		8		14	
8 Carriers			11		11		5		11	
12 Carriers			9		9		3		9	
Mean Gain(dB) ¹	21		20	7	20	7	14	7	20	7
Pin (dBm) ¹	0		0		0		0		0	
Input IP3 (dBm) AGC OFF Min		-10		-5		-5		-5		-5
Input IP3 (dBm) AGC ON Min				5		5		5		5
SFDR ² (dB)		55		68/69/73		72		68		74
Max Intermod Distortion (dBm)	**		-13*		-13		-36		-13	
Max NF (dB)		20		20		20		16		16
Gain Flatness / Ripple (dB) ³	+/-1.0 ⁵		+/-1.5							

* WCDMA compiles with 3GPP TS 25.106 V5.0.0 (2002-03) table 9.4 spectrum emission mask.

**Out of band and spurious emissions compliant with FCC standards.

1 Factory set mean gain BU-RHU without RIU. May be field adjusted using controller system.

2 SFDR for CDMA services is calculated in 100KB/sec.

3 Gain Flatness/Ripple is specified for the non-duplexed port of the system.

4 Specifications include the 900 MHz UL filter. The output power is limited on the downlink.

5 Gain Flatness/Ripple at any block of the spectrum.

6 The SMR 800/900 for Sprint are to be designed, per Sprint guidelines, with composite power levels per antenna port and mean gain values 3dB less than stated.

High Band Services

MA1000 RHU RF Parameters - High Band Services												
MA1000 RHU RF Parameter	DCS		PCS ⁵ CDMA / WCDMA		PCS ⁵ GSM / TDMA		G-PCS ⁶ CDMA/WCDMA		G-PCS ⁶ GSM/TDMA		UMTS and AWS CDMA/WCDMA	
	DL	UL	DL	UL	DL	UL	DL	UL	DL	UL	DL	UL
Max Output Power / Antenna Port												
1 (Composite)	16		20		20		20		21		21	
2 Carriers	13		17		17		17		18		18	
4 Carriers	10		14		14		14		15		15	
8 Carriers	7		11		11		11		12		12	
12 Carriers	5		9		9		9		10		10	
Mean Gain(dB) ¹	16	3	20	3	20	3	20		20	3	21	3
Pin (dBm) ¹	0		0		0		0		1		0	
Input IP3 (dBm) AGC OFF Min		-6		-6		-6		-7		-7		-7
Input IP3 (dBm) AGC ON Min		3		3		3						
SFDR ² (dB)		65		67		70/65		66		64		66
Max Intermod Distortion (dBm)	-30		-13*		-13		-13*		-13		*	
Max NF (dB)		18		18		18						
Gain Flatness / Ripple (dB) ³	+/-2.0											

* WCDMA complies with 3GPP TS 25.106 V5.0.0 (2002-03) table 9.4 spectrum emission mask.

¹Factory set mean gain BU-RHU without RIU. May be field adjusted using controller system.

²SFDR for CDMA services is calculated in 100KB/sec.

³Gain Flatness/Ripple is specified for the non-duplexed port of the system.

⁵The PCS service RF specifications outlined is relevant only for the MA1000 CELL/PCS RHU, CELL/PCS/700LTE TSX, CELL/PCS/AWS TSX and CELL/PCS/700LTE/AWS QSX

⁶The PCS service RF specifications outlined is relevant only for the MA1000 PCS AO and IDEN/SMR/PCS TSX

Absolute Maximum Rating

Total Input RF Power to BU	10dBm
Power Supply	60VDC

Optical Specifications

Optical Output Power	<3.0mW
Max. Optical Budget	2 dB for fiber + 1 dB for Connectors (assumed) = 3 dB total. 300 m Multi-mode
Optical Loss per Mated-pair Connectors	0.5dB (max)
Optical Connector	SC APC
Fiber Type	Single-mode: 9/125um Multi-mode: 50/125 um or 62.5/125um (Minimum qualifications with ANSI/TIA/EIA-568-B series, EN50173-1 or ISO/IEC 11801)
Wavelength	1310±10nm
Maximum Distance Between Base Unit and Remote Cabinet	2km

Multimode Fiber Qualifications

50/125 or 62.5/125um complying with ANSI/TIA/EIA-569-B series, EN50173-1 or ISO/IEC 11801, may be used up to 300 meters in length assuming the following qualifications:

- Both the Base Unit and Remote hub must be multimode capable
- All fiber in a given length of fiber must be of the same core diameter
- All Bulkhead adapters must be single mode SC/APC (Green) adapters
- All terminations, cross connections or patches must be direct fusion splice or one of the Corning MOBILEACCESS cords listed below

900 micro patchcord for splicing, 2 meters, 2xSC/APC

62.5/125/900	Diamond p/n ENC/1045341	FiberNext p/n OEM-629002-MAN
50/125/900	Diamond p/n ENC/1045340	FiberNext p/n OEM-509002-MAN

Zipcord patchcord, 4xSC/APC, 50/125/900/2000/4500 micron

1 meter	Diamond p/n ENC/1045342	FiberNext p/n OEM-50ZIP1-MAN
3 meter	Diamond p/n ENC/1045343	FiberNext p/n OEM-50ZIP3-MAN

Zipcord patchcord, 4xSC/APC, 62.5/125/900/2000/4500 micron

1 meter	Diamond p/n ENC/1045344	FiberNext p/n OEM-62ZIP1-MAN
3 meter	Diamond p/n ENC/1045345	FiberNext p/n OEM-62ZIP3-MAN

Environmental

Operating	0°C to +50°C (32°F to 122°F)
Storage	-20°C to 85°C (-4°F to 185°F)

MA1000 Component Specifications

Base Unit



Models:		4-port; 8-port model
Supported Services:		Wideband device supporting all services supported by MA systems
Power:	Input power	20 to 48V DC
	Power Consumption	14W (8-port BU)
RF Connections:		N-Type Female, 50 ohm – interface to RIU or to passive
BTS Interface Optic Connections:		Four or eight (depending on the model) SC/APC optic connections
Remote Management Controller:		SNMP, NMS via connection to the MA-410, MA-430 or SC-450
Physical Characteristics		Dimensions (WxDxH): 19" x 8" x 1.74" (482.6x203.2x17.4mm) Weight: 3 Kg (6.6 lb.) Mounting: Rack mountable in 19-in rack (mounting brackets included)

RHU



Supported Services:		Two services corresponding to the model
Power:	Input power:	20 to 48V DC
	Power Consumption:	29W
RF Connections:	To antennas:	N-type Female, 50 ohm
	To Add-On:	SMA 50 ohm
Remote Management:		SNMP, NMS via Base Unit connection to the MA-410, MA-430 or SC-450 controller
Physical Characteristics:		Dimensions (WxDxH): 10.98" x 9.5" x 1.74" (278.9x241.3x44.2mm) Weight: 2.8 kg (6.17 lb.)

Add-On



Supported Services:	Single service corresponding to the model
Power:	
Input power:	25-48VDC
Power Consumption:	50W
RF Connections:	
To RHU:	SMA 50 ohm
Remote Management:	SNMP, NMS via RHU connection
Physical Characteristics:	Dimensions (WxDxH): 10.98" x 8.66" x 2.71" (278.9x219.9x68.8mm) Weight: 2.8 kg (6.17 lb.)

Ordering Information

MA1000 QSX

Supported Services	Part Number	Description
CELL/PCS/700 LTE/AWS	1000-C85P19L70A17-A	MA1000 Quad-service package supporting CELL, PCS, 700 MHz LTE and AWS.
	1000M-C85P19L70A17-A	MA1000 Quad-service package supporting CELL, PCS, 700 MHz LTE and AWS with MMF.

MA1000 TSX

Supported Services	Part Number	Description
CELL/PCS/700 LTE	1000-C85P19L70-A	MA1000 TSX tri-service CELL/PCS and 700 MHz LTE.
	1000M-C85P19L70-A	MA1000 TSX tri-service CELL/PCS and 700 MHz LTE with MMF.
CELL/PCS/AWS	1000-C85P19A17-A	MA1000 TSX tri-service CELL/PCS and AWS.
	1000M-C85P19A17-A	MA1000 TSX tri-service CELL/PCS and AWS with MMF.
IDEN/SMR/PCS	1000-IDEN-SMR-G-PCS	MA1000 TSX tri-service iDEN/SMR and PCS with G-Block support.
	1000M-IDEN-SMR-G-PCS	MA1000 TSX tri-service iDEN/SMR and PCS with G-Block support with MMF.
	1000-IDEN-SMR-G-PCSF	MA1000 TSX tri-service iDEN/SMR and PCS with G-Block support and filter to provide additional guard band between iDEN DL and SMR UL.
	1000M-IDEN-SMR-G-PCSF	MA1000 TSX tri-service iDEN/SMR and PCS with G-Block support and filter to provide additional guard band between iDEN DL and SMR UL with MMF.

Base Units

Part Number	Description
WB-B8U	Wide Band Base 8 Unit supporting 8 RHUs
WBM-B8U	Wide Band Base 8 Unit supporting 8 RHUs over MMF
WB-B4U	Wide Band Base 4 Unit supporting 4 RHUs
WBM-B4U	Wide Band Base 4 Unit supporting 4 RHUs over MMF

Remote Hub Unit Modules

Part Number	Description
1000-CELL-4E	Single band CELL, 4 ports, PCS Add-on support
1000-PCS-4E	Single band PCS, 4 ports, AWS Add-on support
1000-DCS-4E	Single band DCS, 4 ports, UMTS Add-on support
1000M-DCS	MMF Single band DCS, 4 ports, UMTS Add-on support
1000-CELL-PCS4E-HL	Dual band CELL/PCS, 4 ports, AWS Add-on support
1000M-CELL-PCS4E-HL	MMF dual band CELL/PCS, 4 ports, AWS Add-on support
1000-CELL-DCS4E	Dual band CELL/DCS, 4 ports, UMTS Add-on support
1000M-GSM-DCS	MMF dual band GSM/DCS 4 ports, UMTS Add-on support
1000-GSM-DCS4E	Dual band GSM/DCS, 4 ports, UMTS Add-on support
1000-GSMO-DCS4E	Dual band GSM orange/DCS, 4 ports, UMTS Add-on support
1000M-iDEN-SMR	MMF dual band iDEN(SMR800)/SMR900 Paging, 4 ports, PCS Add-on support
1000-iDEN-SMR4	Dual band iDEN(SMR800)/SMR900, 4 ports, PCS Add-on support
1000-IDEN-SMR4F	Dual band iDEN(SMR800)/SMR900, 4 ports with filter kit, PCS Add-on support
1000-SMR-FILTER	Filter kit for SMR 900

Add-On Modules

Part Number	Description
700LTE-AO-A-SCU	Add-On kit for LTE 700 MHz service for use in upgrade situations with older MA1000 Cell/PCS RHUs (P/N 1000-CELL-PCS4E and 1000M-CELL-PCS). Includes 700 MHz service combiner unit (SCU-700) and applicable accessories for connecting to the Cell/PCS RHU.
700LTE-AO-B-HL	Add-On for LTE 700 MHz service with MA1000 Cell/PCS RHUs (P/N 1000(M)-CELL-PCS4E-HL)
1200-G-PCS-AO	Add-On RHU Supporting a PCS w/G-Block
1200-UMTSE-AO	Add-On RHU - UMTS Service
1200-AWS-AO	Add-On RHU Supporting AWS Service

Power Supply Accessories

Part Number	Description
LPS-48V-66W	Local AC/DC Converter 66W
LPS-48V-100W	Local AC/DC Converter 100W
AK-PWR-CORD-EU	AC Power Cord for 66W and 100W Power Supplies, European Connector
AK-PWR-CORD-UK	AC Power Cord for 66W and 100W Power Supplies, UK Connector

Mounting Bracket Accessories

Part Number	Description
BRKT-1200-STK	Bracket for stacking RHU/Add-On/860 module on top of an Add-On module
BRKT-1RU-SHELF-2K	Shelf for RHU/Add-On/860 or bracket for stacking on MA2000 MRC
BRKT-RHU-800-STK	Bracket for stacking RHU/Add-On/860 module on top of a RHU/860 module <i>(Note: Not on top of an Add-On)</i>