



**MobileAccessVE
LTE 700 MHz MIMO
Instant Coverage Solution
User Manual**

**P/N: 709C006202
REV: A00
Date: OCT 2010**

MobileAccess

8391 Old Courthouse Road, Suite 300, Vienna, VA 22182

Tel: +1(866)436-9266, +1(703)848-0200 TAC: +1(800)787-1266, Fax: +1(703)848-0280

<http://www.MobileAccess.com>

Preface Material

© Copyright 2010, MobileAccess Networks Inc. All Rights Reserved.

This document contains confidential and proprietary information of MobileAccess and may not be copied, transmitted, stored in a retrieval system or reproduced in any format or media, in whole or in part, without the prior written consent of MobileAccess. Information contained in this document supersedes any previous manuals, guides, specifications, data sheets or other information that may have been provided or made available to the user.

This document is provided for informational purposes only, and MobileAccess does not warrant or guarantee the accuracy, adequacy, quality, validity, completeness or suitability for any purpose of the information contained in this document. MobileAccess reserves the right to make updates, improvements and enhancements to this document and the products to which it relates at any time without prior notice to the user. MOBILEACCESS MAKES NO WARRANTIES, EXPRESS OR IMPLIED, INCLUDING, WITHOUT LIMITATION, THOSE OF MERCHANTABILITY AND FITNESS FOR A PARTICULAR PURPOSE, WITH RESPECT TO THIS DOCUMENT OR ANY INFORMATION CONTAINED HEREIN.

Policy for Warrantee and Repair

MobileAccess tests and inspects all its products to verify their quality and reliability. MobileAccess uses every reasonable precaution to ensure that each unit meets their declared specifications before shipment. Customers should advise their incoming inspection, assembly, and test personnel about the precautions required in handling and testing our products. Many of these precautions can be found in this manual.

The products are covered by the following warranties:

General Warranty

MobileAccess warrants to the original purchaser all standard products sold by MobileAccess to be free of defects in material and workmanship for one (1) year from date of shipment from MobileAccess. During the warranty period, MobileAccess will repair or replace any product that MobileAccess proves to be defective. This warranty does not apply to any product that has been subject to alteration, abuse, improper installation or application, accident, electrical or environmental over-stress, negligence in use, storage, transportation or handling.

Specific Product Warranty Instructions

All MobileAccess products are warranted against defects in workmanship, materials and construction, and to no further extent. Any claim for repair or replacement of units found to be defective on incoming inspection by a customer must be made within (30) days of receipt of shipment, or within (30) days of discovery of a defect within the warranty period.

This warranty is the only warranty made by MobileAccess and is in lieu of all other warranties, expressed or implied. MobileAccess sales agents or representatives are not authorized to make commitments on warranty returns.

Returns

In the event that it is necessary to return any product against above warranty, the following procedure shall be followed:

1. Return authorization is to be received from MobileAccess prior to returning any unit. Advise MobileAccess of the model, serial number, and discrepancy. The unit may then be forwarded to MobileAccess, transportation prepaid. Devices returned collect or without authorization may not be accepted.
2. Prior to repair, MobileAccess will advise the customer of our test results and any charges for repairing customer-caused problems or out-of-warranty conditions etc.
3. Repaired products are warranted for the balance of the original warranty period, or at least 90 days from date of shipment.

Limitations of Liabilities

MobileAccess's liability on any claim, of any kind, including negligence for any loss or damage arising from, connected with, or resulting from the purchase order, contract, quotation, or from the performance or breach thereof, or from the design, manufacture, sale, delivery, installation, inspection, operation or use of any equipment covered by or furnished under this contact, shall in no case exceed the purchase price of the device which gives rise to the claim.

EXCEPT AS EXPRESSLY PROVIDED HEREIN, MOBILEACCESS MAKES NO WARRANTY, EXPRESSED OR IMPLIED, WITH RESPECT TO ANY GOODS, PARTS AND SERVICES PROVIDED IN CONNECTION WITH THIS AGREEMENT INCLUDING, BUT NOT LIMITED TO, THE IMPLIED WARRANTIES OF MERCHANTABILITY AND FITNESS FOR A PARTICULAR PURPOSE. MOBILEACCESS SHALL NOT BE LIABLE FOR ANY OTHER DAMAGE INCLUDING, BUT NOT LIMITED TO, INDIRECT, SPECIAL OR CONSEQUENTIAL DAMAGES ARISING OUT OF OR IN CONNECTION WITH FURNISHING OF GOODS, PARTS AND SERVICE HEREUNDER, OR THE PERFORMANCE, USE OF, OR INABILITY TO USE THE GOODS, PARTS AND SERVICE.

Reporting Defects

The units were inspected before shipment and found to be free of mechanical and electrical defects.

Examine the units for any damage that may have been caused in transit. If damage is discovered, file a claim with the freight carrier immediately. Notify MobileAccess as soon as possible.

Note: Keep all packing material until you have completed the inspection

Safety Warnings

To comply with FCC RF exposure compliance requirement, adhere to the following warnings:

Warning! The Access Pod with its built-in antenna must be installed with a separation distance of at least 20cm from all persons and must not be located in conjunction with any other antenna.

Warning! The outside antenna must be installed with a separation of at least 20cm from all persons and must not be located in conjunction with any other antenna.

Warning! Use of this Access Pod with antennas other than those illustrated could be hazardous. Before using other antennas, contact MobileAccess Support.

Caution: Double pole/neutral fusing (two fuses in the appliance inlet)

Approved Antennas for use with the MobileAccessVE Solution

The gain of external antennas connected to the VAPs should not exceed 10 dBi.

Compliance with RF Safety Requirements

MobileAccess products have no inherent significant RF radiation.

The RF level on the down link is very low at the downlink ports. Therefore, there is no dangerous RF radiation when the antenna is not connected.

Certification and Compliance to Standards

Category	Standards
Safety:	IEC 60950-1: 2003; UL-60950-1:2003; CAN/CSA – C22.2 No 60950-1-03
EMC:	47CFR 15.109 FCC Part 15
Radio:	FCC Part 27
ISO 9001	2000 and ISO 13485: 2003

About This Guide

This guide provides essential product functionality with all the information necessary for proper installation and configuration of the MobileAccess**VE** system.

List of Acronyms

Abbreviation	Description
LTE	Long Term Evolution
MIMO	Multiple Input Multiple Output
PoE	Power Over Ethernet
PSE	Power Sourcing Equipment
SME	Small / Medium Enterprise
STP	Shielded Twisted Pair
UTP	Unshielded Twisted Pair
VAP	VE Access Pod
VCU	VE Control Unit

Table of Contents

1	Overview	1
1.1	Key Features and Capabilities	2
1.2	System Architecture	3
1.3	System Elements	4
1.3.1	VE Control Unit (VCU)	4
1.3.1.1	VCU Front Panel	4
1.3.1.2	VCU Rear Panel	6
1.3.2	VE Access Pod (VAP)	6
1.4	System Monitoring and Management	8
1.4.1	Integration with an External Fault Management System	8
2	Installation Workflow	9
3	Infrastructure Requirements and Layout Planning	10
3.1	General Information on Location and Connections	10
3.2	Infrastructure Requirements	11
3.3	Coverage and Installation Planning	12
3.3.1	Types of Environments	12
3.3.1.1	Standard Environment	13
3.3.1.2	Open Environment	13
3.3.1.3	Dense Environment:	13
3.3.1.4	Combination of Environments	13
3.4	Planning VAP Layout	14
3.4.1	RF Coverage Factors	14
3.4.2	Mapping Locations	14
3.4.3	Optional Directional Antennas	14
3.4.4	Installation Plan Example	15
4	VCU Unit Installation and Provisioning	17
4.1	VCU Kit Contents	17
4.2	VCU Physical Installation	18
4.2.1	Master VCU Installation	18
4.2.1.1	Master VCU Alarm Output Connections	19
4.2.2	Slave VCU Installation	20
4.3	Ethernet Cable Connections to VAPs	21

4.3.1	Shifting Relevant Ethernet LAN Connections.....	21
4.3.2	Operation with LAN utilizing Power over Ethernet (PoE).....	23
4.4	Provisioning the VE Control Unit.....	23
4.4.1	Configure the Computer IP Parameters.....	23
4.4.2	Provisioning the Master VCU Unit	24
4.4.3	Setting RF Parameters	29
4.4.4	Verifying System Operation	31
4.4.5	Provisioning the Slave VCUs	34
5	VAP Installation and Provisioning	35
5.1	VAP Installation	35
5.2	Desk and Wall Mount VAP Installations	36
5.2.1	VAP Kit Contents	36
5.2.2	Desk Mount Installation	37
5.2.3	Wall Mount Installation	38
5.3	Horizontal Ceiling Mount VAP Installations.....	39
5.3.1	VAP Kit Contents	39
5.3.2	Lowered Ceiling Installation	40
5.3.3	Concrete/Wood Ceiling Installation	41
5.3.4	Connecting VAP and Verifying Normal Operation	43
5.4	Vertical Ceiling Mount VAP Installations.....	44
5.4.1	VAP Kit Contents	44
5.4.2	Lowered Ceiling Installation	45
5.4.3	Concrete/Wood Ceiling Installation	47
5.4.4	Connecting VAP and Verifying Normal Operation	49
5.5	Verifying VAP Coverage Area	49
5.6	Naming the VAPs, Verifying Connections and Monitoring	50
5.7	Provisioning the VAPs.....	50
5.7.1	Verifying Normal VAP Operation	50
5.7.2	Naming the VAP	51
6	Navigating the Web Access Application	52
6.1	Opening a Session and Authentication Levels	52
6.2	About the MobileAccessVE Web Access Window	53
6.3	Configuration Tab	54
6.3.1	Network Topology Tree	55
6.3.1.1	Removing Network Element from Baseline	56
6.3.2	Configuration Display Area	57

6.4 Management Tab.....	58
7 VCU Monitoring and Configuration.....	59
7.1 Viewing VCU General Information	59
7.2 Viewing VCU Alarms.....	60
7.3 Master VCU RF Parameters.....	61
8 VAP Monitoring and Configuration.....	63
8.1 Viewing VAP General Information	63
8.2 Viewing VAP Alarms	64
8.3 VAP RF Parameters	65
9 Administrative Operations.....	67
9.1 Changing Password.....	67
9.2 Retrieving VCU IP Address.....	68
9.3 IP Settings	69
9.4 SNMP Configuration Parameters	71
9.5 Upgrading (or Downgrading) VCU and VAP Software	72
9.5.1 Upgrading the VAP SW	73
9.5.2 Upgrading the VCU SW	75
10 Troubleshooting.....	76
10.1 Finding a Specific VAP in the Building	76
10.2 Wireless Service is Not Available	78
10.3 PoE is Not Working	78
10.4 Ethernet Service is Degraded.....	79
10.5 No Service from Connected Access Pod	79
10.6 VCU Cannot be Monitored via SNMP.....	81
Appendices	82
Traps	82

1 Overview

The MobileAccess**VE** LTE 700 MHz MIMO solution provides enhanced, cost effective, in-building LTE MIMO coverage for any small-to-large sized enterprise environment. This solution is quickly and easily deployed using the existing Ethernet cabling infrastructure without affecting existing LAN services or performance.

The VE solution distributes LTE MIMO service to VE Access Pods (VAPs) installed throughout the enterprise, which distribute the services via integrated internal antennas (or optional external antennas), and provide Ethernet connectivity and PoE pass-through to LAN terminals. MobileAccess**VE** seamlessly coexists with the Enterprise LAN and does not consume LAN capacity.

The VAPs are distributed on each floor and plug into existing standard Ethernet jacks. They are powered via PoE technology and managed via a VE Control Unit (VCU) located in the floor's IDF/Telco closet. For site coverage that requires more than one VCU, several VCUs can be aggregated under a single Master VCU. The Master VCU provides the interface to the carrier's capacity sources and management.

This enhanced LTE 700 MHz MIMO coverage solution can be quickly and easily installed with minimal disturbance to the enterprise. In less than a few hours and with no additional cables being required, a scalable and flexible solution is provided at a significantly lower total installation cost.

The following figures illustrate *single-tier* and *multi-tier* VE installations.

In a single-tier installation the VCU is connected to both the service provider's equipment and the Ethernet switch, and distributes Ethernet and mobile services to up to 12 VAPs distributed over one more adjacent floors.

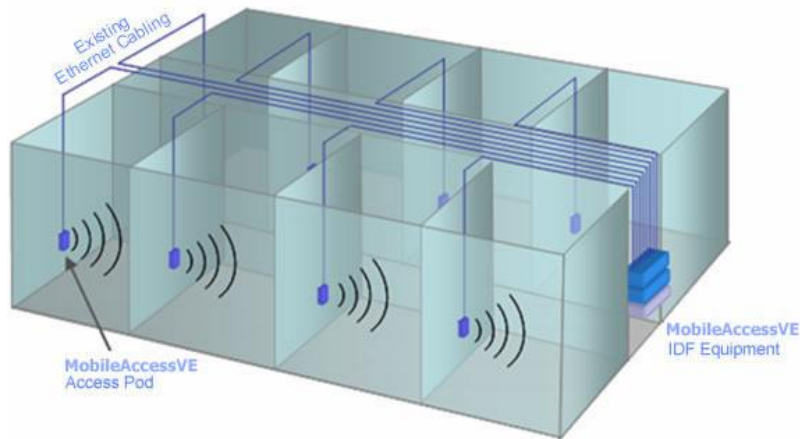

Figure 1-1. Single-Tier VE Installation

Multi-tier installation includes the Master VCU that supports up to 12 Slave VCUs. In this type of installation the provider's services are fed to the Master VCU through which the Slave VCUs are controlled and managed.

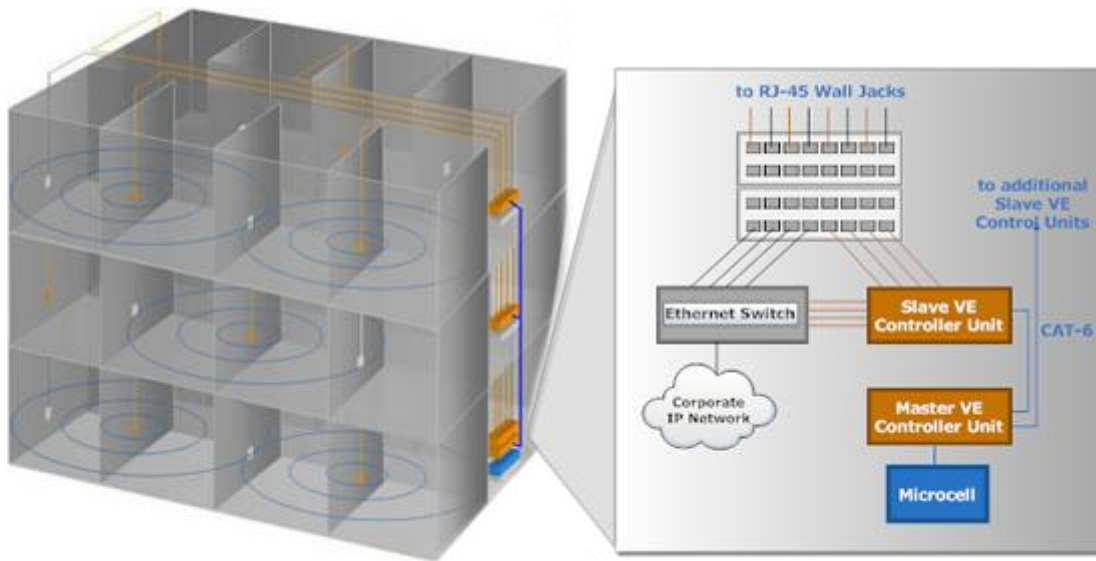

Figure 1-2. Multi-Tier VE Installation

1.1 Key Features and Capabilities

- Simple Installation - Deployed in only a few hours, with minimum disturbance to the enterprise.
- VAPs connect over existing CAT-5e/6 cabling infrastructure and existing Ethernet jacks.
- VAPs are remotely powered using Power-over-Ethernet (PoE). Local power is not required.
- Minimum macro-network impact with low power distributed coverage.
- Seamlessly coexists with the Enterprise LAN and does not consume LAN capacity.
- Connects to all types of capacity sources, including BTS, picocells, femtocells, and BDAs.
- VAPs can easily be relocated for coverage modifications as needed.
- Ease of expansion provides "pay as you grow" scalability.
- Support of connected IP devices (Wi-Fi APs, IP phones, etc.) with Ethernet/IP pass through and PoE maximizes placement flexibility.
- Remote end-to-end system monitoring, management, and configuration via a single connection to the master VCU using a standard web browser and SNMP.
- Base Line feature that clearly shows VAPs/VCUs where communication has been lost.

1.2 System Architecture

Main Elements - The MobileAccessVE solution is based on the following main elements:

- **VE Control Unit (VCU)** – Provides interface to up to 12 VAPs, and the central interface for managing the VE deployment. In Master/Slave mode, it can serve to expand the network coverage with additional VCUs serving as Slaves and a single control point at the Master. Slave mode is automatically detected when a Slave VCU detects that it is connected to the Master VCU.
 - **Master VE Control Unit (Master VCU)** – Installed in the main IDF/Telco closet, the Master VCU interfaces with the service provider's RF capacity sources and provides secure, central management to up to twelve VCUs and VAP devices in any combination. The Master and Slave VCUs are connected using *dedicated* CAT-6/7 cables.
 - **Slave VE Control Unit (Slave VCU)** – Installed in the IDF/Telco closet and used to expand coverage to additional floors. Each VCU interfaces the Master VCU and up to 12 VAPs and 12 Ethernet connections.

VCUs distribute wireless service signals to each VAP along with PoE and where relevant, Ethernet signals from the Ethernet switch, throughout the existing CAT-5e/6 infrastructure.

- **VE Access Pod (VAP)** – VAPs are pluggable antennas distributed at strategic locations on the floor to provide Ethernet connection to an IP device and wireless coverage of the service via integrated internal (or external) antennas. Power to VAPs is provided via PoE from the VCU.

Up to twelve VAPs can be connected to a single VCU using LAN cables (CAT-5e or higher).

Note: When the total number of VAPs in the deployment exceeds 72, consult with MobileAccess support.

The following figure shows the Multi-tier VE LTE 700 MHz MIMO solution architecture.

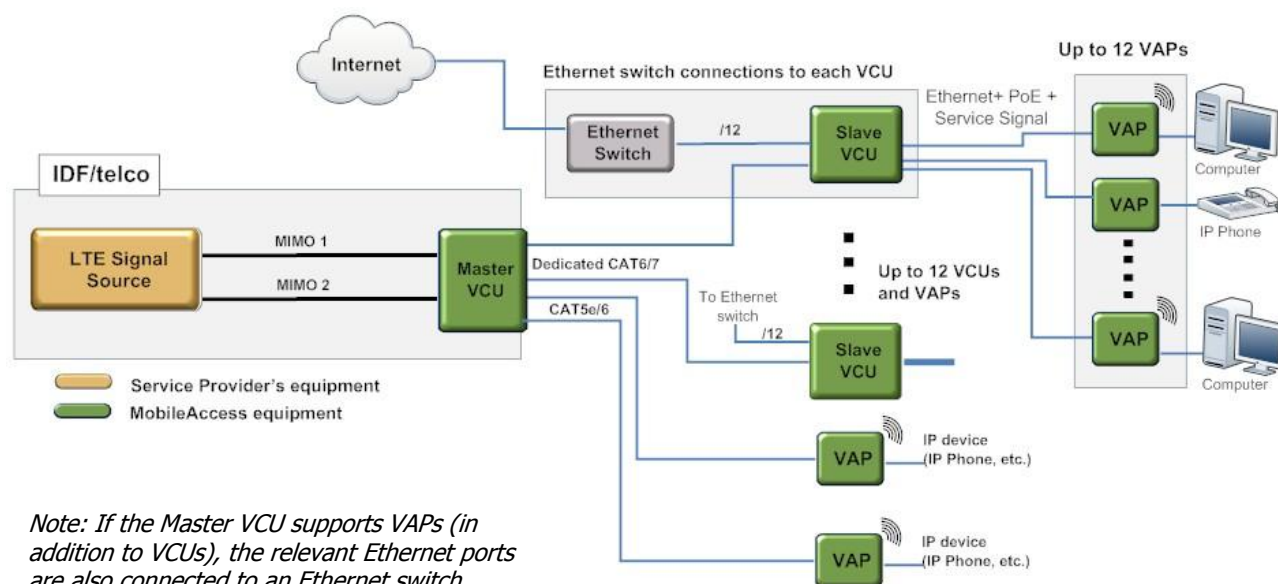

Figure 1-3. VE Multi-Tier Basic Architecture

The Master VCU distributes the wireless MIMO services from the service provider's equipment to the Slave VCUs. At the Slave VCUs, the wireless MIMO services are converged with Ethernet service and routed to the VAPs via the Ethernet LAN CAT-5e/6 cabling infrastructure.

The VAPs distribute the wireless LTE MIMO service via integrated internal antennas or optional external antennas and provide Ethernet/IP connectivity, and PoE pass-through, to the connected appliances such as Wi-Fi APs and IP phones.

1.3 System Elements

This chapter describes the interfaces of the VE Control Units and Access Pods.

1.3.1 VE Control Unit (VCU)

While operating as a Master VCU:

- Interfaces to RF source(s) and to VCUs/VAPs.
- Converges Wireless services and distribution to Slave VCUs.
- Slave VCUs and VAP management and control.
- Remote management of the entire deployment.

While operating as a Slave VCU:

- Interfaces to Master VCU.
- Converges Wireless services, Ethernet and PoE and interfaces to VAPs.
- Management and control of connected VAPs.

1.3.1.1 VCU Front Panel

The front panel supports the interfaces to the wireless LTE MIMO service (two channels – corresponding to the two supported TDD MIMO channels) and includes interfaces to VAPs or Slave VCUs depending on the configuration.

The following provides the front panel ports.

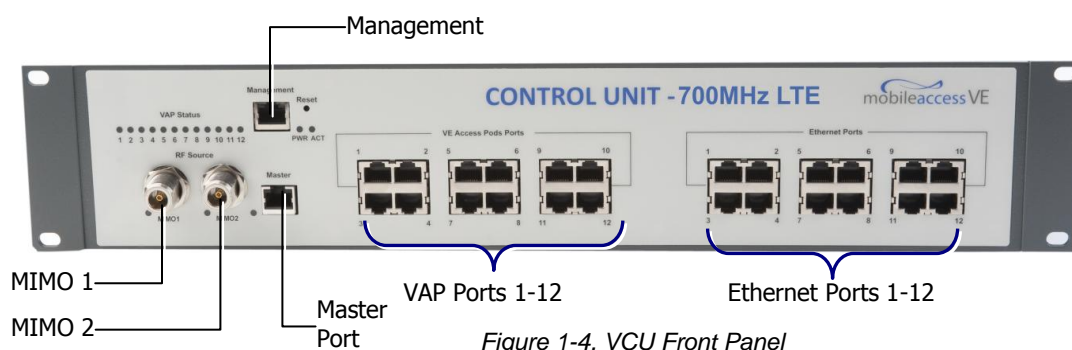

Table 1: VCU Ports Description

Ports	Description
MIMO1 MIMO2	RF connections (two TDD MIMO channels) to the service provider LTE Signal Source equipment. N-Type female connectors. Coax cables. <i>Note: When supporting SISO service – only MIMO 1 connector is relevant.</i>
Management	RJ45 web management connection.
VE Access Pod Ports 1-12	VAP/VCU port connections. For Master VCU – Connections to Slave VCUs or VAPs. For Slave VCU – Connections to VAPs.
Ethernet Ports 1-12	Relevant only for Slave VCUs. Ethernet switch connections.
Master	Used for connecting a Slave VCU to the Master VCU in a multi-tier deployment. Connects to one of the VAP ports of the Master VCU.
Reset	N/A in current version.

The following provides a description of the front panel LEDs.

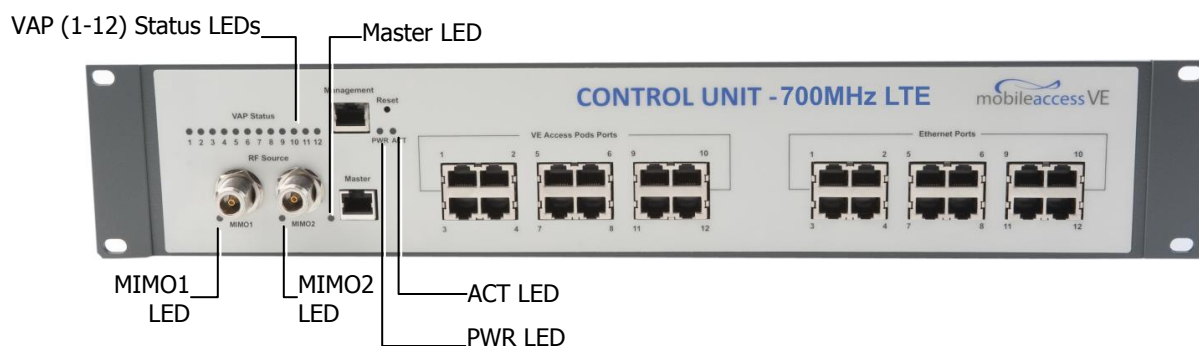

Table 2: VCU LEDs Description

LED	Description
PWR	Indicates whether the VCU receives power: Green – Power OK Disabled – No power received by VCU
ACT	VCU activity LED: Solid Green – During initialization Blinking Green – Normal system operation Fast Blinking Green – User activated <i>VCU Identify</i> on this VCU
VAP Status (One LED per Port)	Indicates the status of the <i>corresponding</i> unit (VAP or VCU): Blinking Green – Unit is initializing Solid Green – Normal operation of unit Solid Orange – Unit is faulty, or unmanaged. This can be due to mismatch type, VoIP phone, etc. Fast Blinking Green – User invoked "Identify" command on the unit Off – No VAP or VCU connected to this port.
MIMO (One LED per Channel)	Indicates the status of connected RF capacity source: Green – Master VCU only. Normal RF level Orange – Master VCU only. RF level is either too low, too high, or service has been turned off by the user. Off – VCU is Slave.
Master	Indicates the status of the connection to the Master VCU: Off – Master mode (not connected to VCU) Blinking Green – During Attachment process with Master VCU Solid green – Slave (IF-IF) mode and connected to Master

1.3.1.2 VCU Rear Panel

The rear panel includes the following: power switch, AC input, AUX alarms, and service personnel connections.

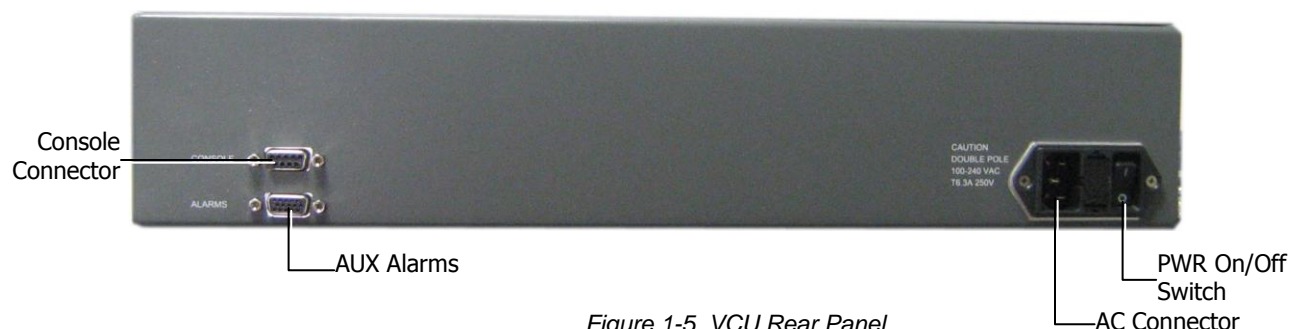

Figure 1-5. VCU Rear Panel

Table 3: VCU Rear Panel Description

Connector	Description
Console	RS232 local connection for service personnel (D-Type 9)
Alarms	AUX alarms connections(See section 4.2.1.1). <i>In Master/Slave configuration - relevant only for Master VCU.</i>
Power Input	Standard 3-pins AC power connector equipped with an ON/OFF switch. 90-264V AC, 47-63 Hz AC; 350W power consumption maximum.

1.3.2 VE Access Pod (VAP)

Each VAP supports:

- Two interfaces for external antennas. By default, the VAP is set to transmit through the external antennas. *Note: Do not change the "External Antenna" option in VAP Config-Service RF tab of the VE Web GUI application.* (See section 8.3).
- An Ethernet port for physical Ethernet connection to devices such as a computer, IP phone or Wi-Fi Access Point.
- Two LED status indicators

The VAP is provided with brackets for either hanging the device on the wall or placing it on a flat surface (such as a desk).

Note: Ceiling Mount Kits can be ordered separately. (P/N: Horizontal: AK-CEILING-MT-H or Vertical: AK-CEILING-MT-V).

The following figure shows the desktop VAP.



Figure 1-6. VE Access Pod-Front

Table 4: VAP LEDs

LED	Description
Power	Solid Green - Power supplied to VAP
	Off - No power supplied to VAP
Activity	Off - No power supplied to VAP or Overall Status of VAP is faulty
	Blinking Blue - Power on, VAP is initializing (connecting to VCU)
	Solid Blue - Power on, unit operating normally
	Fast Blinking Blue - User invoked "Identify" command on corresponding VAP

The following figure shows the desktop VAP rear side and the underside view with the CAT-5e/6 patch-cord cable.

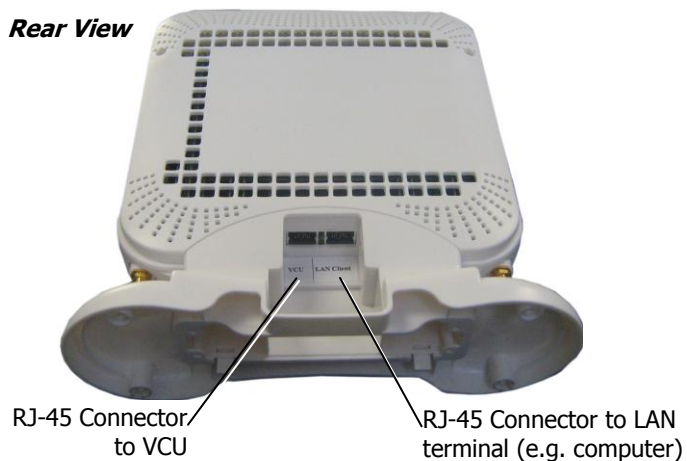

Figure 1-7. VE Access Pod-Rear

1.4 System Monitoring and Management

The MobileAccess**VE** system (Master VCU, Slave VCUs, and VAPs) is centrally managed via a single Web connection to the Master VCU. The basic screen in the GUI is the **Config** tab, which enables the user to view the system topology and setup parameters, Control Units, and all Access Pods connected to the Control Units.

Note: When locally connecting to a specific Slave VCU, only the VAPs connected to this VCU can be monitored. However, when connected to the Master, the entire deployment can be monitored.



1.4.1 Integration with an External Fault Management System

The MobileAccess**VE** system can be seamlessly integrated into any existing Fault Management (FM) system that supports SNMP events. The Master VCU generates a SNMP event for each relevant system alarm and forwards this trap to the pre-configured IP address of the external Fault Management system.

2 Installation Workflow

The following figure summarizes the main steps of the installation procedure:

Installation Workflow

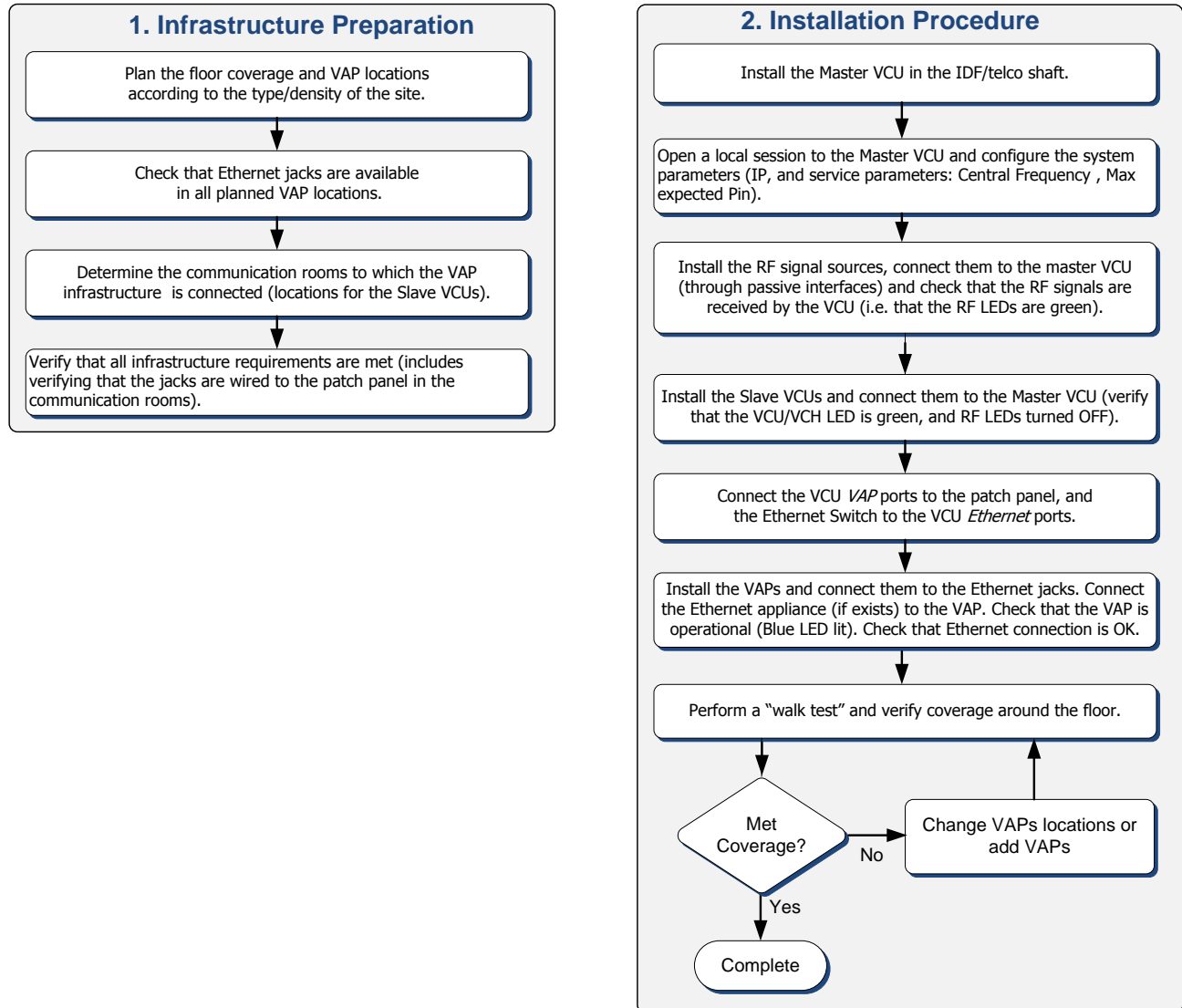

3 Infrastructure Requirements and Layout Planning

3.1 General Information on Location and Connections

- Service provider's RF equipment - macrocell, microcell, picocell, femtocell, BDA, etc. connects to the VCU through a passive interface.
- VCUs:
 - Master VCU installed at the main IDF/Telco cabinet and connected to all VCUs.
 - Slave VCUs installed at the IDF/Telco cabinet of each covered floor and connected to the Master VCU, the Ethernet switch, and the VAPs through the cabling patch panel.
- Wireless service signals from Master VCU to VCUs – Routed through dedicated Ethernet CAT-6/7 cabling.
- Wireless service signals from VCUs to the VAPs – Routed through existing Ethernet CAT-5e/6 cabling infrastructure.
- VAP location and mounting. Connection to existing Ethernet jack and external antennas.
- VAP power source - No power connections required. VAPs are power fed from VCU using PoE (Power over Ethernet) technology.

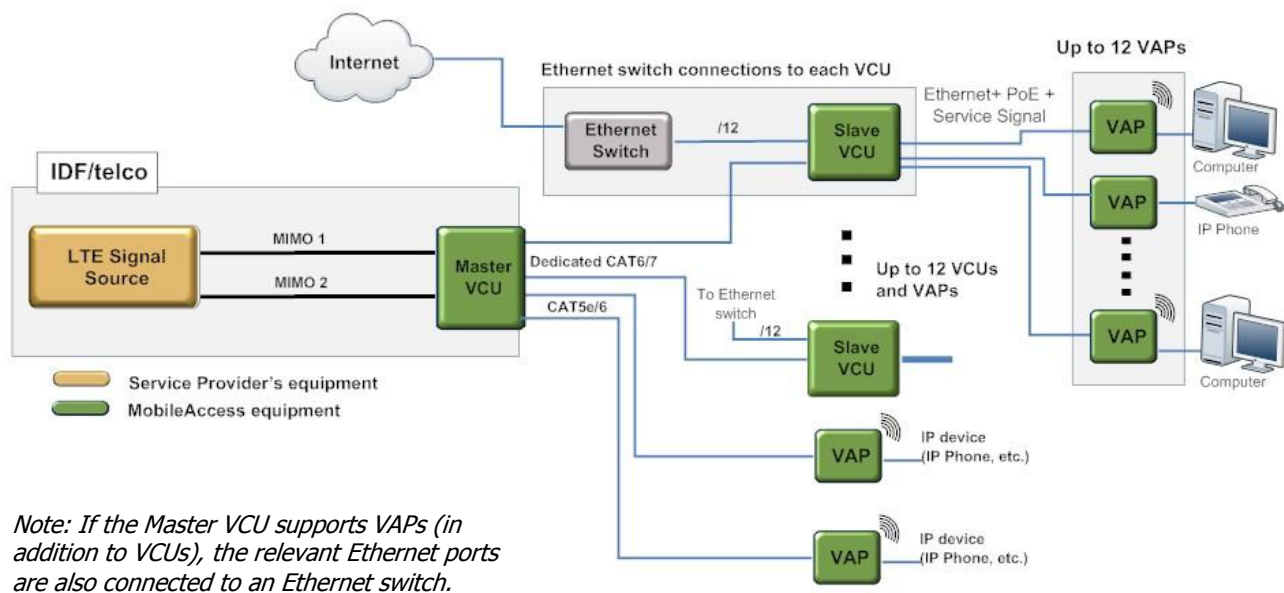

Figure 3-1. VE Multi-Tier Basic Architecture

Note: connecting both VAPs and slave VCUs simultaneously to the master VCU is supported for VE networks running SW version 2.6 and above.

3.2 Infrastructure Requirements

Ethernet standards specify that the maximum distance between an Ethernet switch and an appliance (computer, WLAN AP, etc) should not exceed 100m (300ft). Therefore, when VE shares the IT LAN, the maximum distance for a given cable run cannot be longer than 100m (300ft) between the Ethernet switch and appliance, including all patch cords (from switch to VCU, from VCU to patch panel, from RJ-45 outlet to VAP, and from VAP to appliance).

Typically the horizontal cabling system will be connected to patch-panels in the communication rooms. The entire cabling system, including the patch panels and patch cords, should adhere to the CAT-5e/6 standard. Specifically all pairs of the CAT-5e cable should be wired in the patch panels and patch cords.

1. IDF/Telco closet space for one or more VCUs depending on the number and locations of the installed VCUs: (48.3cm x 51.3cm x 8.88cm) per VCU.

Note: When planning the IDF/Telco shaft, take the RF equipment (picocell/microcell or BDA) and the VCU into consideration.

2. 350 Watts of AC power to the VCU IDF/Telco closet.
3. Building infrastructure:
 - CAT-5e/6 cabling, Shielded Twisted Pair (STP)
 - 24 AWG minimum diameter for CAT-5e cabling
 - Dedicated CAT-6/7 STP cable from Master VCU to Slave VCUs with run lengths NOT exceeding 100m (300ft) and no shorter than 10m (33ft).
 - CAT-5e/6 STP cable from VCU to each VAP with run lengths NOT exceeding 100m (300ft) and no shorter than 10m (33ft). VAPs can be connected over existing CAT-5e/6 cabling infrastructure and existing Ethernet jacks without affecting the LAN.

Note: Verify with the IT department that the existing cables can support the VE installation. If available, review the infrastructure documentation to determine cable types and lengths. If the infrastructure documentation is not available, attempt to visually identify the cable type. Depending on the cable vendor, the cable type may be listed on the cable sheath. It is recommended to use a Fluke cable tester to measure the cable length of the most remote VAPs.

4. Master VCU Cable Connections:
 - (2) N-type female, 50 ohm interfaces to carrier equipment
 - (Up to 12) RJ-45 interfaces to Slave VCUs and/or VAPs
 - (1) RJ-45 interface to Management
 - (1) D-Type 9 pins RS-232 interface for local craft
 - (1) D-Type 15 pins interface for External Alarms (dry contacts)
5. Slave VCU Cable Connections:
 - (1) RJ-45 interface to Master VCU (Not used in small single-tier deployments)
 - (12) RJ-45 interfaces to VAPs
 - (12) RJ-45 interfaces to Ethernet Switch for LAN service
 - (1) D-Type 9 pins RS-232 interface for local craft

3.3 Coverage and Installation Planning

Note: The following section provides information required for planning the VAP installation on a single floor. In a multi-tier installation, this procedure is performed for each individual floor.

The maximal coverage area of each VAP is affected by the density and type of environment being covered. Therefore, it is recommended to determine the location in two phases:

- Plan the *ideal* location of each VAP in order to achieve complete coverage of the floor.
- Select the *exact* location according to the location feasibility, where each VAP unit may be wall or desk mounted and an option for an external antenna is available.

The supplied services (wireless only or Ethernet and wireless) depend on the jack to which the VAP is connected:

- If the jack supports an active Ethernet connection, the VAP will distribute LAN traffic along with the wireless service. (See section 4.3).
- If the jack is not currently active (not connected to an Ethernet switch), the VAP will distribute only the wireless services.

This section provides information on coverage criteria in various types of environments (Open, Standard, Dense and Merged) and provides rules-of-thumb for various installations of the VAPs.

Note: Section 3.4 provides a detailed example of installation planning in various types of environment. It is recommended to review this example after reading this section.

3.3.1 Types of Environments

This section describes the different types of installation environments and provides guidelines for best coverage of each type of space.

The coverage guidelines in this section are conservative “rule of thumb” estimates of RF coverage per VAP, meant to be used in scenarios in which detailed designs are not performed. When the coverage layout is designed, the coverage per VAP is expected to increase by up to 33%. Coverage estimates in this section assume 25% overlap between the coverage areas of neighboring VAPs to ensure robust, full coverage throughout the enterprise with no “dead zones”.

3.3.1.1 **Standard Environment**

A traditional office environment with offices, hallways, and scattered cubicles.

Table 5: Standard Environment Installation Distances

Signal Propagation from VAP	56 feet (19 m)
Recommended Spacing between VAPs	112 feet (38 m)
Recommended Maximum distance of VAPs from outer walls	56 feet (19 m)
Coverage area per VAP	9,900 sqft (920 sqm)

3.3.1.2 **Open Environment**

An environment with minimal obstacles (e.g. walls). This type of space can be a large conference or meeting room, cubical areas, lobby, or atrium.

Table 6: Open Environment Installation Distances

Signal Propagation from VAP	64 feet (21 m)
Recommend spacing between VAPs	128 feet (42 m)
Recommended maximum distance of VAPs from outer walls	64 feet (21 m)
Coverage area per VAP	12,750 sqft (1,185 sqm)

3.3.1.3 **Dense Environment:**

A dense environment consists of a relatively large amount of walls, offices, equipment, tall file cabinets, bookshelves, and other items that could potentially impact the wireless signal.

Examples include dense offices, hospitals, and manufacturing spaces.

Table 7: Dense Environment Installation Distances

Signal Propagation from VAP	41 feet (13.5 m)
Recommended Spacing between VAPs	82 feet (27 m)
Recommended Maximum distance of VAPs from outer walls	41 feet (13.5 m)
Coverage area per VAP	5,300 sqft (495 sqm)

3.3.1.4 **Combination of Environments**

In areas with a combination of environments, place VAPs on the border between the different environment types, slightly closer to the denser area.

For example, in a cubical area with the outside wall having offices, simply locate the VAPs a little *closer to the outside offices* to provide coverage through the office walls. (See VAPs 11 and 13 in the floor plan map in section 3.4.3.). To ensure maximal coverage, VAPs can be re-located or added. If a coverage gap is detected, the VAPs can be re-located until coverage gaps are filled.

3.4 Planning VAP Layout

The following section describes the steps of planning VAPs along the covered floor. At the end of this section an example of a planning map is provided.

Note: It is highly recommended to use a floor plan when planning the VAPs locations.

3.4.1 RF Coverage Factors

It is important to note the type of factors that can severely impact RF coverage, and should be avoided:

- **Metallic Structures** such as elevators, high file cabinets, and some moveable metallic partitions severely degrade RF signals. All efforts should be made to locate VAPs in front of, or above metallic objects (desks, filing cabinets) to allow the signal to propagate.
- **Wall Materials** such as concrete, tile, and cinderblock, as well as bathroom fixtures typically have fairly high signal attenuation and should be considered as dense spaces.
- **Types of Glass** that have metallic coatings can affect RF coverage, typically exterior or mirrored. However this issue is not normally encountered inside a building.

3.4.2 Mapping Locations

To Map the VAP Locations

1. Map out the available Ethernet jack locations and mark all CAT-5e/6 drop locations on the floor plan map.

TIP: The size and number of the ceiling tiles can be used to measure distances.

2. Using the floor plan and the VAPs coverage guidelines as provided in section 3.4.3, mark approximately where you would like to place each VAP in the facility.
VAPs may be added or removed as needed for optimal coverage.
3. For each jack being used to connect a VAP, check if the jack is already connected to the Ethernet switch. .
4. Connect the Ethernet cables corresponding to the selected jacks according to section 4.3.
5. It is also recommended to check the area where each VAP will be installed to ensure the installation is feasible.

3.4.3 Optional Directional Antennas

Each VAP has an integrated internal antenna that provides isotropic radiation. To prevent interference and improve coverage, connect directional antennas to VAPs installed near outer walls. The VAP antenna parameter must be set accordingly via the Web GUI. (See section 8.3).

3.4.4 Installation Plan Example

The following figure shows a floor plan map with all required marks:

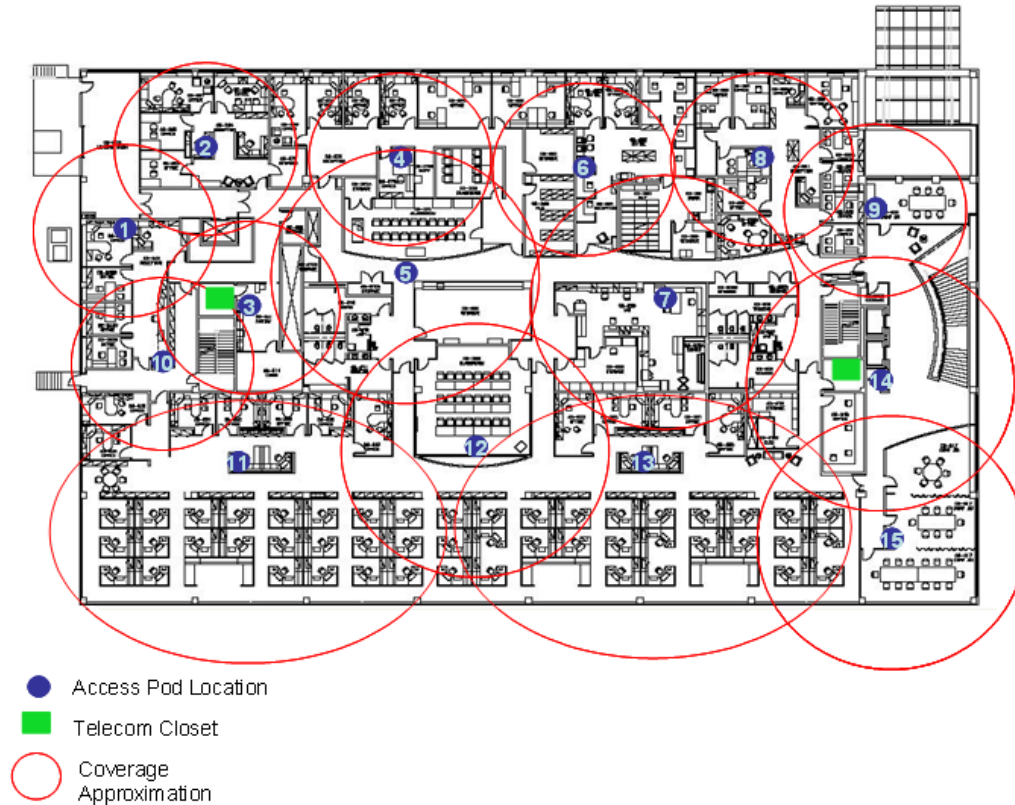

Figure 3-2. Floor Plan Example

Notes:

- The red VAP coverage circles have an approximate radius of 41, 56, and 64 foot (13.5, 19, and 21 meters) for the small, medium, and large circles respectively, which are drawn according to the guidelines given in section 3.3.1.
- VAP 3 is surrounded by the bathroom and stairwell which are considered dense objects and would reduce coverage in that area by the other VAPs.
- VAP 5 is an example of a unit that provides good coverage down the hallways in an Open Environment.
- VAPs 11 and 13 are placed closer to the offices to provide better coverage to them, but on the open side will actually cover a much greater area. This is why the coverage is larger and shown here more as an oval than a circle.
- The area between VAPs 7 and 14 would probably be the lowest coverage spot in the building because of the bathrooms and stairwell on either side. If after the system is installed, this area is still a little low on coverage, a VAP can be added, but it may also be covered by VAP 14.

Note: The plan can be modified at any time by moving the units around or by adding units.

4 VCU Unit Installation and Provisioning

This chapter describes the installation and *basic configuration procedures* for VE Control Units (VCU) located on each floor.





In addition, this chapter describes the how to shift the relevant Ethernet connections required for the VAPs.

These steps should only be performed after planning the floor coverage and installation locations, as described in the previous sections.

4.1 VCU Kit Contents

The VE VCU Kit includes:

Table 8: VCU Kit

Description	Unit
VE LTE 700 MHz MIMO Control Unit (VCU) Kit	
Power Cord	
VE SW CD	
Local Configuration Cable (Crossed RJ-45 cable)	
Brackets Used to secure the VCU to a 19" rack (Shipped assembled to the VCU)	

4.2 VCU Physical Installation

This section describes the physical installation and connections of the Master VCU, Slave VCUs and the VAP Ethernet connections to the relevant VCUs.

4.2.1 Master VCU Installation

The VE Control Unit can be installed as a Master VCU and control up to (12) Slave VCUs and VAPs and is installed in the main IDF/Telco closet. This section describes the Master VCU installation procedures.

*Note: When Master VCU only supports Slave VCUs (no VAPs), the control units' **Ethernet Ports** are not relevant and are not in use.*

1. Install the **Master VCU** in the main IDF/Telco closet. The Master VCU can be installed in a rack, placed on a shelf, or secured using the supplied bracket.
2. Apply power to the Master VCU and verify that the **PWR** LED is lit. Also verify that the unit ACT LED completes initialization (blinking light) and shows a solid green light.
3. Connect (or request the service provider's service personnel to connect) the provider's **signal source** (macrocell, microcell, BTS, or BDA etc.) to the **Master VCU front panel RF ports** (through passive interface). Power on the signal sources.

Note: The RF Source LED (See following figure) of the connected port on the Master VCU should be lit GREEN, indicating that the Master VCU senses the RF signal from the source at the expected level (according to Max Expected Pin). After connecting the capacity source, if the LED remains RED verify that the Max Expected Pin is configured properly and service is enabled.

4. To connect VCU Slaves to the Master VCU: connect the **Master VCU VAP ports** to the **Slave VCUs Master** ports via the patch-panel that feeds the dedicated CAT-6/7 cabling system.
5. To connect Auxiliary alarms refer to section 4.2.1.1. *Note: Connector located on the controller rear panel.*
6. According to VAPs layout plan, as explained in section 3.4.2, connect the Ethernet switch cables. (See section 4.3 for more detailed explanation).
 - If the requested jack is already in use, disconnect it from the Ethernet switch and re-connect it to the corresponding **Ethernet** port in the Slave VCU front panel.

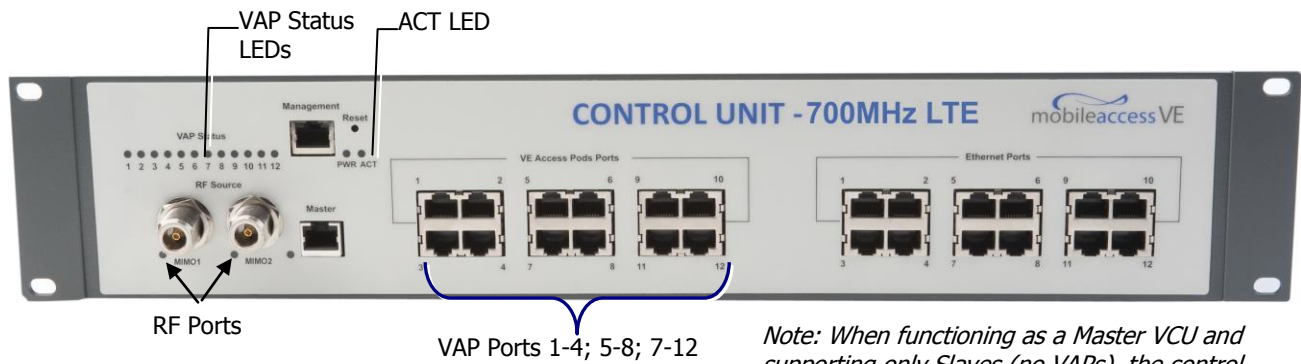

*Note: When functioning as a Master VCU and supporting only Slaves (no VAPs), the control units' **Ethernet Ports** are not relevant. The Ethernet ports are only relevant when supporting mixed mode – Slave VCUs and VAPs.*

*Note: After the Slave VCUs are connected (according to section 4.2.2), verify that that the Master VCU **VAP Status LEDs**, which correspond to the connected Slave VCUs complete initialization (blinking light) and show a solid green light.*

4.2.1.1 Master VCU Alarm Output Connections

Note: For Master/Slave VCU configuration, the Alarms are relevant only for the Master VCU.

The auxiliary connections are performed through the Master VCU rear panel **Alarms** port. See following figure.

The controller can provide Major and Minor Output Alarms. These alarms can be connected directly to either the auxiliary input of the Base Station or to any additional dry-contact application.



A Major Alarm is generated when there is an alarm condition in one or more VCUs, while a Minor Alarm is generated when there is an alarm condition in one or more of the VAPs.

Note: If only one alarm is required (Minor or Major) an external connection of a wire jumper between pins 8 and 13 is necessary (Normally closed).

Connect the relevant alarms according to the connector pinout below.

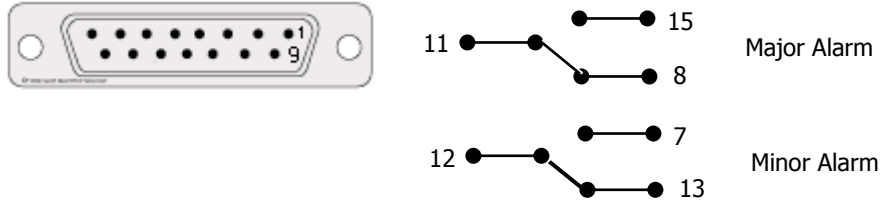

Table 9. Alarms Connector – used pins

8 – Major Error Signal (Normally closed)	7 – Minor Error Signal (Normally open)
11 – Major COM	12 – Minor COM
15 –Major Error Signal (Normally open)	13 – Minor Error Signal (Normally closed)

4.2.2 Slave VCU Installation

1. Install the Slave VE Control Unit (VCU) in the IDF/Telco closet corresponding to the floor being covered. The Slave VCU can be installed in the rack using the supplied bracket. Apply power to the Slave VCUs and note that the VCU **PWR** LED is lit. Note that the unit ACT LED completes initialization (solid light) and shows a blinking green light. See Figure 4-1.

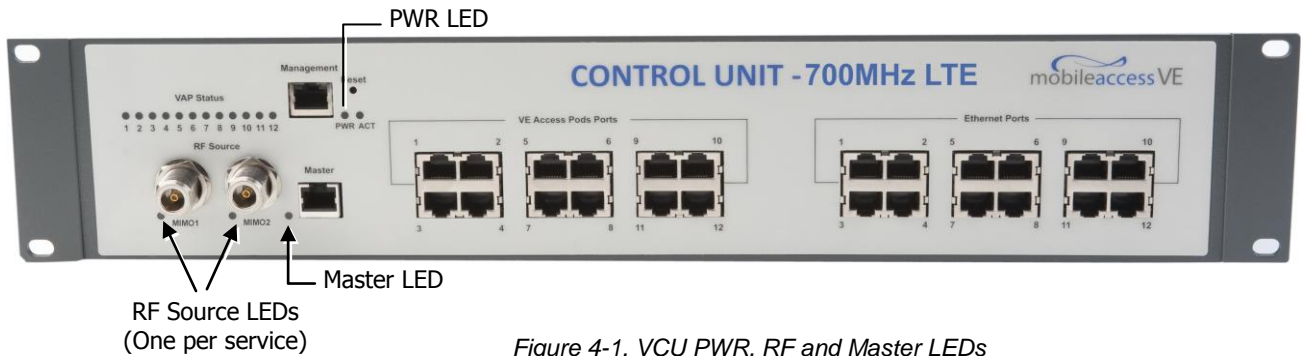

Figure 4-1. VCU PWR, RF and Master LEDs

2. Connect the Slave VCU front panel **Master** port to the Master VCU **VAP** port via the patch panel using dedicated CAT-6 cables. Verify that the Master LED completes initialization (blinking light) and shows a solid green light. The (RF) MIMO LEDs (of both services) should turn OFF.

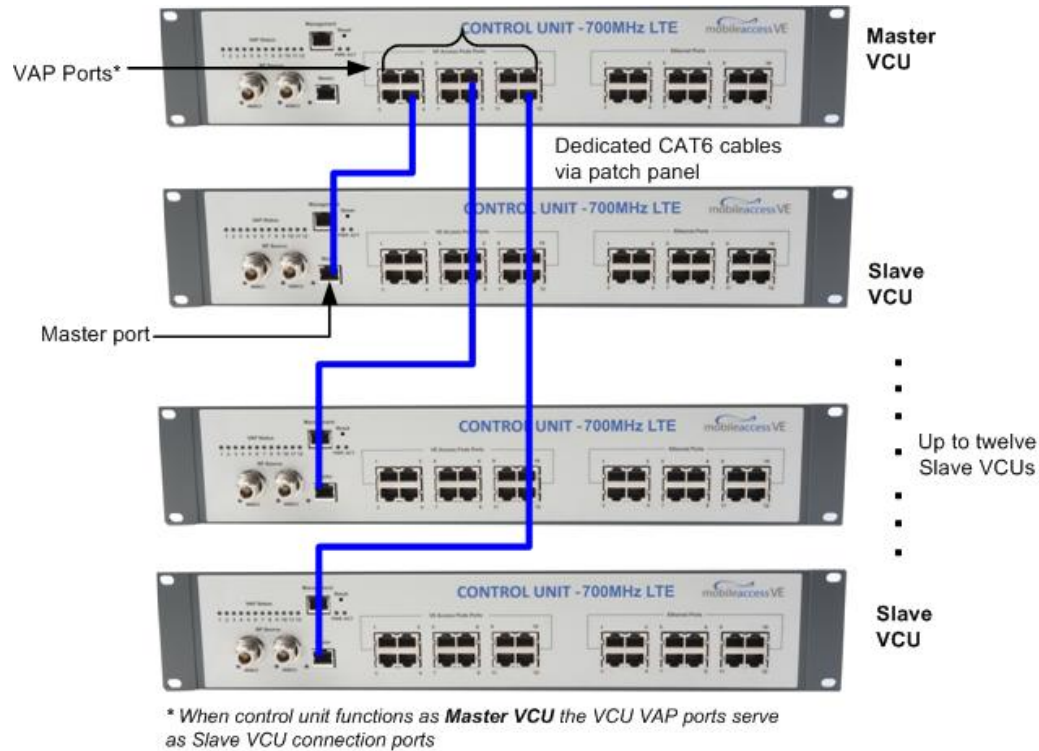

Figure 4-2. Master and Slave VCU Connections

3. Connect the Slave VCU **VAP** ports to the patch-panel that feeds the existing structured CAT-5e/6 cabling system.
4. According to VAPs layout plan, as explained in section 3.4.2, connect the Ethernet switch cables. (See section 4.3 for more detailed explanation).
 - If the requested jack is already in use, disconnect it from the Ethernet switch and re-connect it to the corresponding **Ethernet** port in the Slave VCU front panel.

4.3 Ethernet Cable Connections to VAPs

This section describes the how to perform the relevant Ethernet LAN connections to the VAPs from the VCUs via the Ethernet switch (See section 4.3.1) and provides a description of the PoE transferred between the VCU and the VAPs. (See section 4.3.2).

4.3.1 Shifting Relevant Ethernet LAN Connections

For VAPs installed on currently ACTIVE Ethernet ports, shift the relevant Ethernet LAN connections to the Ethernet ports on the Master or Slave VCU.

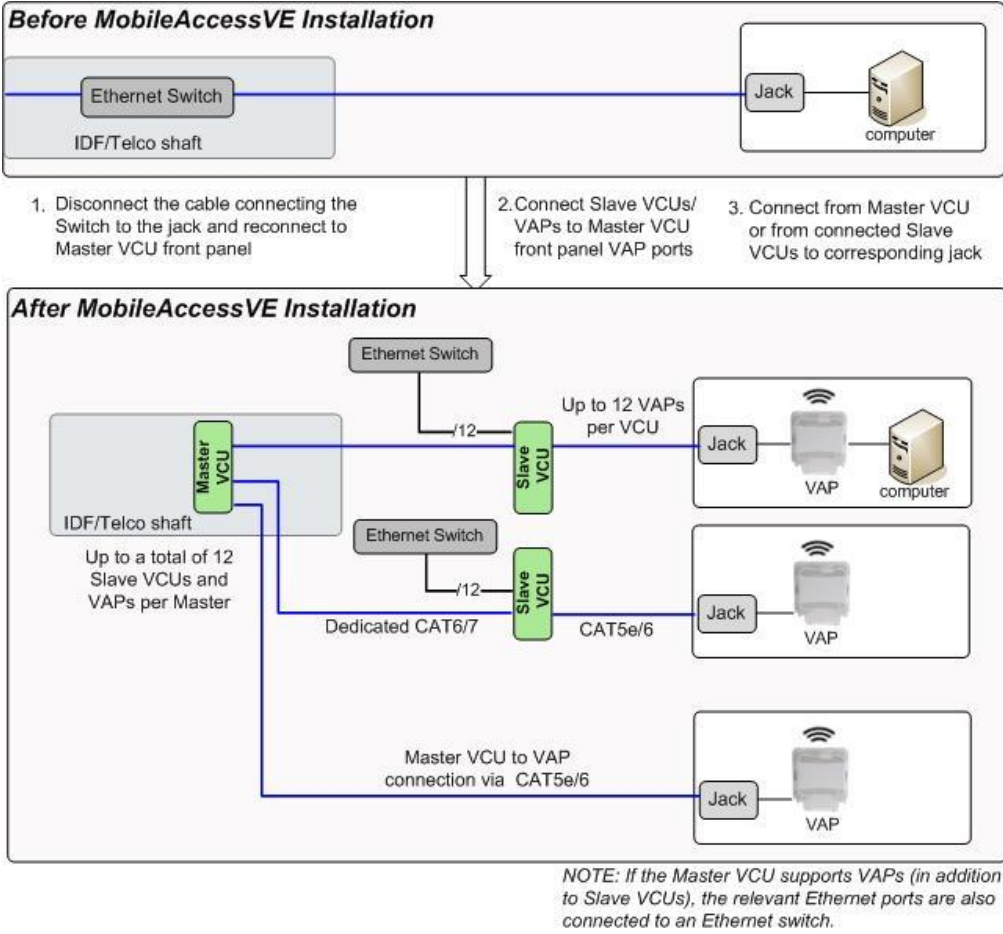

For VAPs installed on currently INACTIVE Ethernet ports, connect as follows.

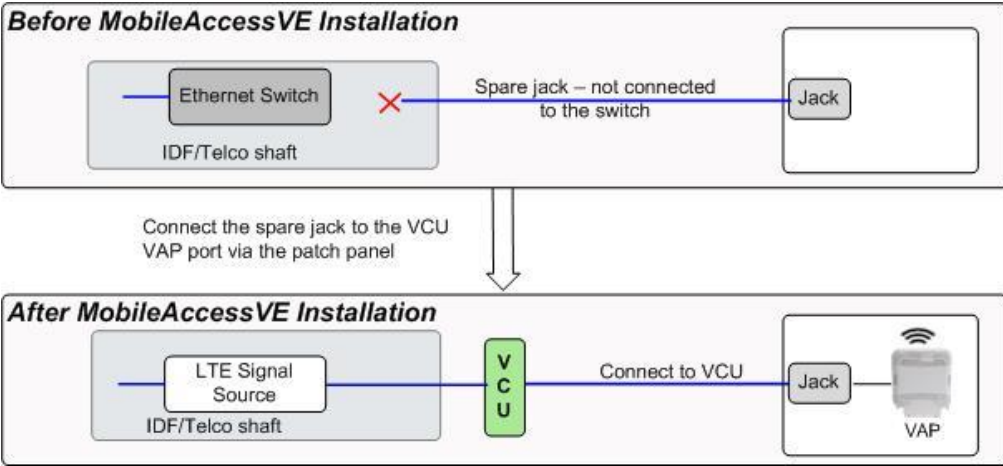

Note: After the Slave VCUs are installed and connected to the correct ports in the patch panels, please proceed with the VAP installation as described in chapter 5 . However, it is recommended to complete the VCU provisioning first (See section 4.4) because when installing the VAPs they will instantly provide the wireless service and the installer will be able to check the coverage.

4.3.2 Operation with LAN utilizing Power over Ethernet (PoE)

Power over Ethernet (PoE) is a technology that enables passing electrical power over the Ethernet cabling. Power can either come from a PoE-enabled Ethernet device (e.g. switch) or from a "mid-span" device built specifically for "injecting" power into the Ethernet cabling.

PoE can operate over two different pairs in a CAT-5e/6 cable. These two methods are referred to as "alternative a" and "alternative b". All PoE compatible appliances, such as WLAN APs and IP phones, support both alternatives and automatically detect and use the power on the appropriate pairs (alternative a or b).

MobileAccess**VE** supports sharing LAN infrastructures that use either 802.3af PoE or 802.3at PoE.

In the current release MobileAccess**VE** supports operation with "**alternative a" PoE**.

Note: Future enhancements will support coexistence with "alternative b" PoE. If this is currently required, consult MobileAccess.

4.4 Provisioning the VE Control Unit

This chapter describes how to set the basic parameters required for operation and remote management of the Master VCU using the Web GUI. The configuration dialogs are fully described in Chapter 6 .

The Master or Slave mode is automatically detected according to the VCU's physical connection. If a connection to another VCU is detected, the VCU will be identified as a Slave, otherwise it will assume the role of a Master.

Notes:

- 1. The initial configuration of the Master VCU is performed via local connection using a cross-cable and connecting to VCUs default IP address. After performing the initial configuration and assigning the Master VCU an IP address, the system can be connected, monitored, and configured via a remote management connection.*
 - 2. The configuration and management of all of the system units (VCUs and VAPs) is performed via local or remote connection to the Master VCU unit.*
-

4.4.1 Configure the Computer IP Parameters

Configure the computer local LAN connection to operate in the same subnet as the default VCU IP address. Note that the procedure may vary slightly depending on the operating system installed on your computer. The following procedure is for Windows XP.

To Configure the Computer's IP Parameters:

1. Click the **Start** menu and choose **Control Panel**.
2. In the **Control Panel**, click **Network and Internet Connections**.
3. Click **Network Connections** and then double-click **Local Area Connection**.

The Local Area Connections Properties dialog box appears with the General tab displayed by default.

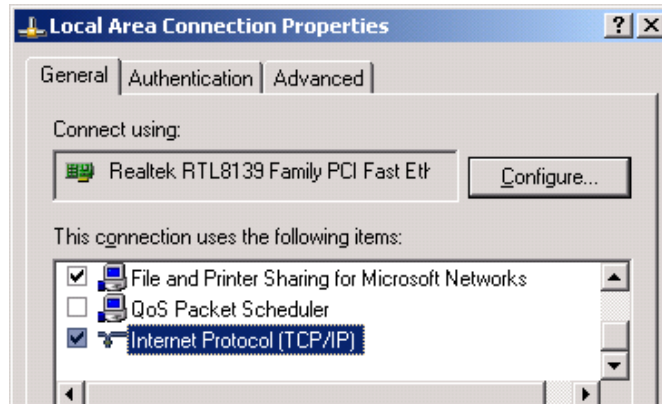

4. In the Items list, select "Internet Protocol (TCP*IP)" and click the Properties button.
5. The "Internet Protocol (TCP/IP) Properties" dialog appears.

Note: The Master VCU is supplied with the default IP address 192.168.1.1.

- In order to communicate with the unit, it is necessary to assign your computer a *Static IP* address in the same subnet: 192.168.1.2 to 192.168.1.250. (i.e. 192.168.1.9 as shown in the example).
- Define the subnet mask as shown: 255.255.255.0

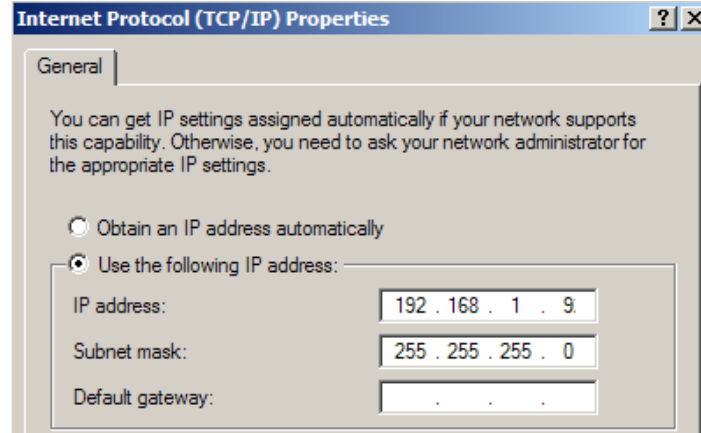

6. Click **OK**.
7. The computer communication parameters are now defined and you can open a session to the Master VCU and provision the unit.

4.4.2 Provisioning the Master VCU Unit

1. Perform a local connection to the Master VCU unit by connecting the Master VCU front panel **Management** port and a laptop computer.

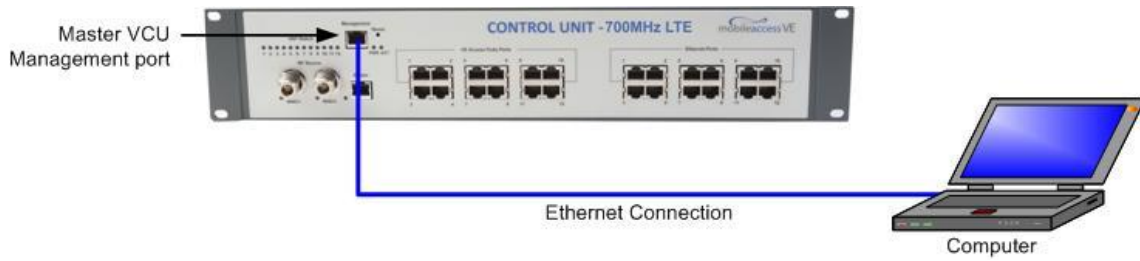

- Open a web browser and type the Master VCU IP address in the address bar (Default: 192.168.1.1).

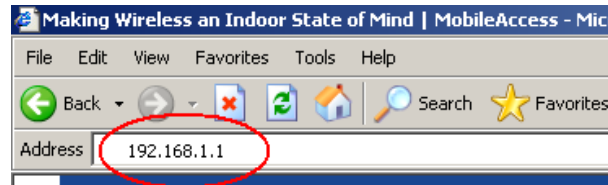

Note: If you have forgotten the VCU IP address and/or want to change it, it can be retrieved via the IP Recovery Tool application provided on the Setup CD. See 9.2.

The Login window appears.



- Type the **User Name "engineer"** and enter the **Password "eng"**.

The MobileAccessVE Web GUI appears.



4. Choose the **Management** tab in the main menu bar and click the **IP Settings** tab on the side bar.

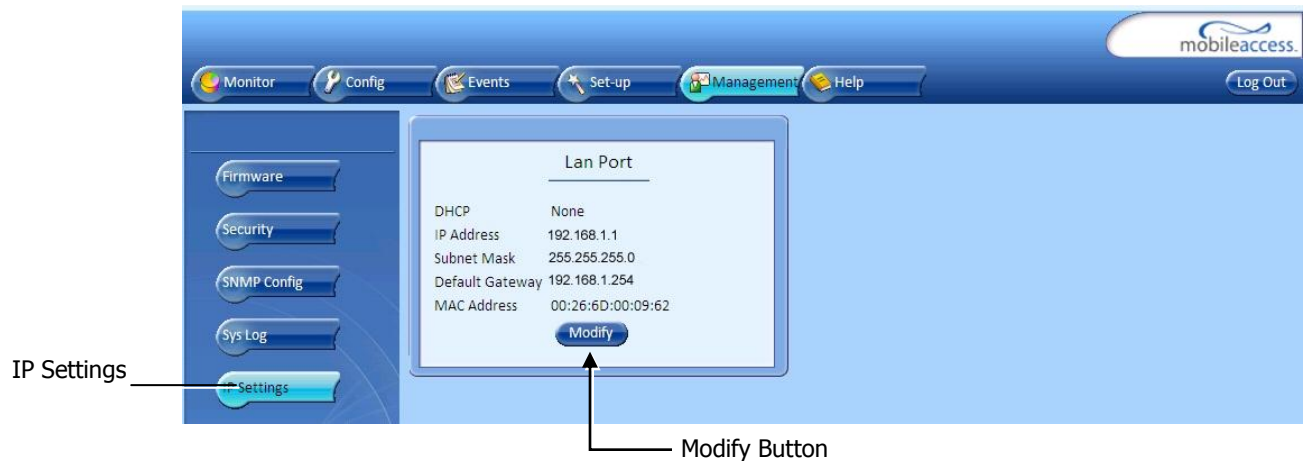

Note: See section 6.4 for a description of the Management tab.

5. Click the **Modify** button to define the STATIC **IP Address** according to existing LAN.

Note: After the initial IP configuration, the Master VCU can be accessed remotely via Ethernet.



- Set the Static IP address parameter (DHCP is not currently available)
Default definitions:
 - The Default IP Address: 192.168.1.1
 - The Default Subnet Mask: 255.255.255.0
 - The Default Gateway: 192.168.1.254
 - Click **OK**.
6. Log out and then log in again with the new IP settings.
 7. Select the **Config** tab in the main menu bar.

*Note: See section 6.3 for a complete description of the **Config** tab.*

8. The Master VCU appears in the Network Topology Tree as **VCU-M**. Select the Master VCU by clicking on it.

The screenshot shows the MobileAccessVE configuration interface. At the top, there is a navigation bar with tabs: Monitor, Config (highlighted), Events, Set-up, Management, and Help. A 'Log Out' button is in the top right corner. On the left, a 'Network Topology Tree' shows a hierarchy starting with 'MobileAccessVE', followed by 'VCU-M - LTE' (labeled as 'Master VCU'), and then a list of VAPs (VAP1 through VAP9). The main area displays a 3D model of the VCU hardware. Below the model, there are two tabs: 'Module Info' (circled in red) and 'RF Parameters'. The 'Module Info' tab is active, showing fields for Name (LTE), Serial Number (00101200039), Product Revision (N/A), SW Active Version (2.5), and SW Inactive Version (N/A). There are 'Modify' buttons for the Name and Date/Time fields. Below this, there are 'Restart VCU' and 'Identify' buttons. A 'VCU Alarms & Mask' section is also visible, listing various alarms with checkboxes.

9. Before configuring the Master VCU it is recommended to give the unit an identifiable name. To assign the Master VCU an identifiable name:

- Select the **Module Info Tab** and click the **Modify** button.

This is a close-up of the 'Module Info' tab from the previous screenshot. It shows the 'Name' field containing 'LTE' and a 'Modify' button next to it. An arrow points from the text 'Click Modify button.' to this 'Modify' button. Other fields include 'Serial Number' (00101200039), 'Product Revision' (N/A), 'SW Active Version' (2.5), and 'SW Inactive Version' (N/A). There are also 'Restart VCU' and 'Identify' buttons.

- Type the unit name in the **Controller Name** dialog and click **OK**. *Note: Up to 17 alphanumeric characters are allowed.*

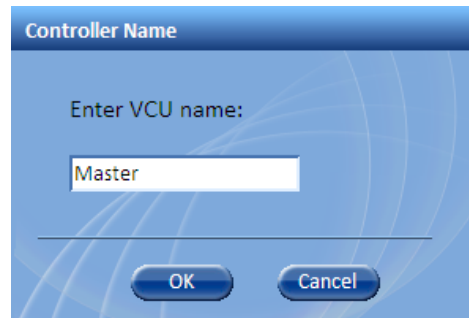

4.4.3 Setting RF Parameters

In a Master-Slave mode (multi-tier architecture) the RF parameters are only configured for the Master VCU unit.

Set the RF parameters according to the LTE Signal Source transmission configuration (MIMO or SISO). Each type of configuration is defined through a dedicated tab.

This section describes the MIMO and the SISO configuration procedures.

To Configure the MIMO RF Parameters:

1. Select the Master VCU in the topology tree and then select the **RF Parameters** tab. Verify that the **Service Mode** parameter is defined as **MIMO**.

Note: The MIMO DL CF parameter is Read Only and pre-defined for the supported 10 MHz block. The MIMO DL CF parameter defines the same DL central frequency from the Base Station for Channel 1 and Channel 2.

2. Define Max expected power of BTS (0-33dBm).
3. Define UL System Gain (-15 to 5dB)

Notes:

1. Max expected Pin parameter can be obtained from your service provider.
2. The remaining parameters are predefined to their default values. (Service Bandwidth is set to 10MHz per channel).
3. Any updates of the service definition (Service Mode) are sent to all connected VAPs.

To Configure the SISO RF Parameters:

Note: The RF tab is displayed for MIMO by default.

1. Select the Master VCU in the topology tree and select the **SISO** option in the **Service Mode** drop-down list. The RF parameters tab will display the SISO RF parameters.

The screenshot shows the MobileAccessVE configuration interface. On the left, a topology tree lists 'MobileAccessVE' and 'VCU-M-LTE' with sub-items VAP1 through VAP9. The main area displays a VCU hardware unit. Below the unit, there are two panels: 'VCU Alarms & Mask' and 'Module Info'. The 'Module Info' panel has a 'RF Parameters' tab selected. In this tab, the 'Service Mode' is set to 'SISO' (indicated by a blue arrow pointing to the dropdown menu). Other parameters shown include 'Type: LTE-Band 13 (Upper C)', 'DL CF: 751.0 MHz', 'Max Exp Pin: 0 dBm', 'UL System Gain: 0 dB', and 'Channel 1 Pin: LOW'. A red 'Overall Status' indicator is visible in the 'VCU Alarms & Mask' panel.

Service Mode
drop-down list

2. Define Max expected power of BTS (0-33dBm).
3. Define UL System Gain (-15 to 5dB)

Notes:

1. Max expected Pin and SISO DL CF parameters can be obtained from your service provider.
2. The remaining parameters are predefined to their default values. (Service Bandwidth is set to 10 MHz).
3. Any updates of the service definition (DL CF or Service Mode) are sent to all connected VAPs.

4.4.4 Verifying System Operation

To verify proper operation of the system, refer to the **VCU Alarms and Mask** sub-tab (in the Config tab). The following figure illustrates the MIMO alarms.

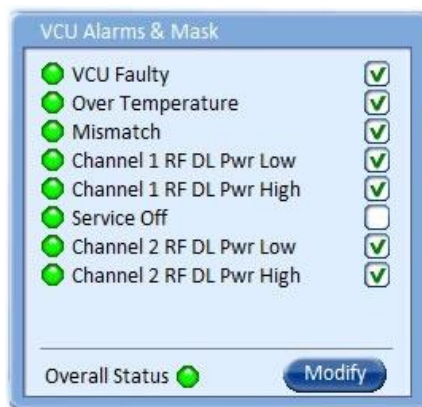

*Note: SISO alarms are similar, however only **Channel 1** alarms appear.*

1. Verify that all the alarms are GREEN.

Refer to the alarm descriptions in the following table.

Note: When SISO service is used only the Channel 1 alarms are relevant.

Alarm	Description
VCU Faulty	RED - VCU fault. Remove and re-apply power to VCU. If problem persists, replace VCU.
Over Temperature	Temperature of unit exceeds normal range.
Service Off	User has disabled the service.
Channel 1 RF DL Pwr Low	RED - DL RF Power is lower by 15dBm (or more) from the Max Expected Pin.
Channel 1 RF DL Pwr High	RED - the input power exceeds the maximum expected Pin by more than 3 dB.
Channel 2 RF DL Pwr Low	RED - DL RF Power is lower by 15dB (or more) from the Max Expected Pin.
Channel 2 RF DL Pwr High	RED - the input power exceeds the maximum expected Pin by more than 3 dB.
Overall Status	Indicates Fault (RED) level or GREEN if there are no faults.

Note: To briefly check the VCU status, click on the VCU name in the Topology Tree. The VCU icon will appear, showing the LEDs status.



- Mask irrelevant alarm conditions to avoid affecting the overall status of the unit. See following example.

For Example

Note: Channel DL signal refers to the MIMO/SISO DL signal from the BS side towards the remote units (VAPs).

In the example below “Channel 2 RF DL Pwr High” alarm is masked (Disabled). This is the alarm for the DL signal (from the BS side).

The left dialog shows the alarm response when Channel 2 DL RF Pwr High alarm is enabled and a fault corresponding to that alarm is detected. (MIMO 2 DL RF Power exceeds the defined range). The overall status will be RED indicating a fault.

The right side dialog shows the alarm response when Channel 2 DL RF Pwr High alarm is masked (Disabled). The Channel 2 DL RF Pwr High LED will appear RED; but, the overall status will be GREEN, showing NO Fault.

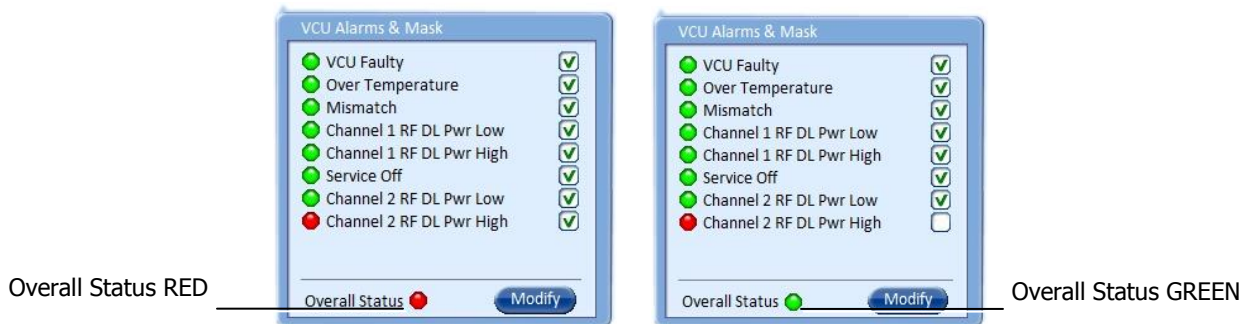
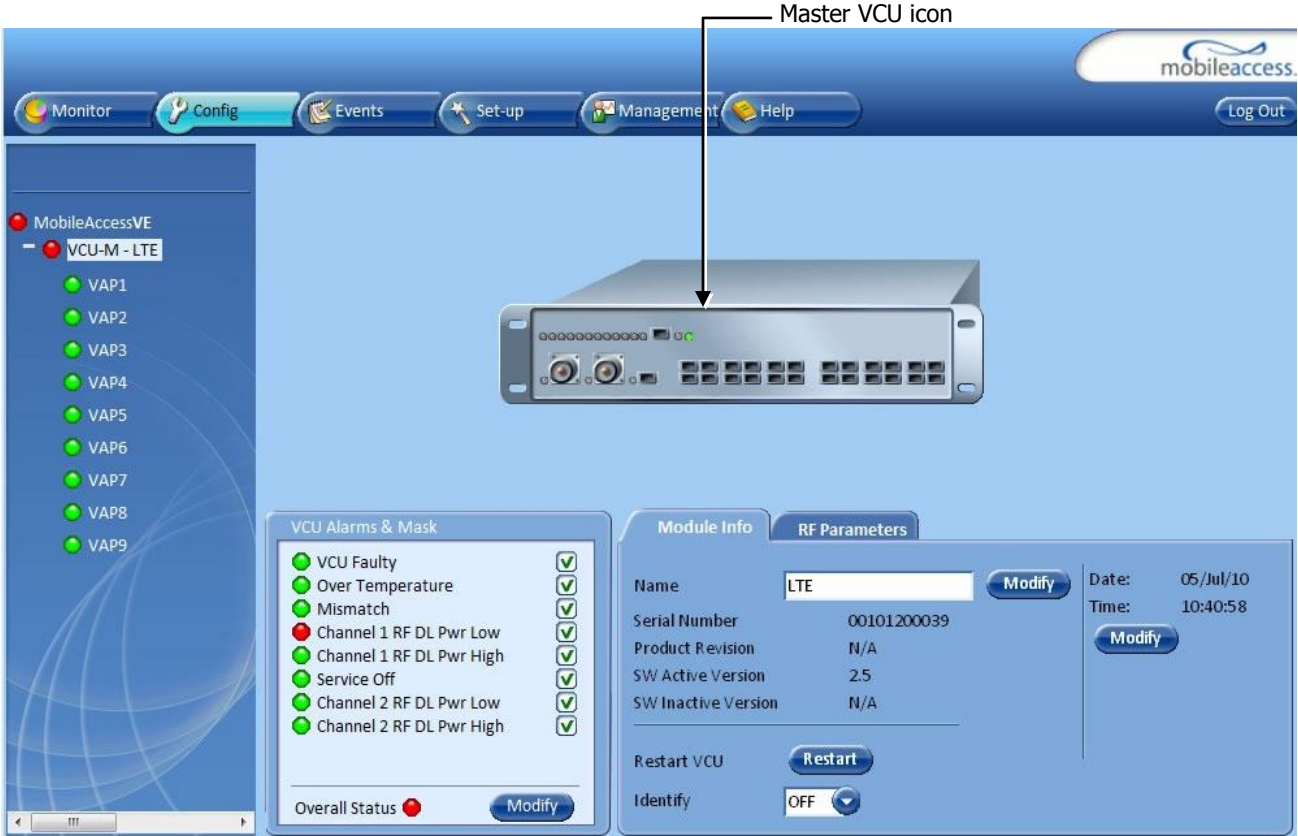

Figure 4-3. Service2 Service Off Alarm – Unmasked

Figure 4-4. . Service2 Service Off Alarm –Masked

Note: To briefly check the VCU status, click on the VCU name in the Topology Tree. The VCU icon will appear, showing the LEDs status.



4.4.5 Provisioning the Slave VCUs

Note: The Slave VCUs management and configuration is performed through a remote connection to the Master VCU, via the web management. Before provisioning the Slave VCUs verify that the Master VCU unit, to which it is connected, has been provisioned (See section 4.4.1).

The Slave VCU RF parameters are set via the Master VCU, therefore there is no need to configure the RF parameters individually for each connected Slave VCU. It is recommended to assign each Slave VCU an identifiable name.

To Assign a Name to a Slave VCU:

1. Connect to the Master VCU unit (either locally as explained in section 4.4.1 or remotely) and select the Slave VCU to be provisioned from the Network Topology Tree.

Each VCU has a default name of the form "VCUPx-name", where:

- **Px** - Master VCU port number to which the Slave VCU is connected
 - **Name** - User-defined name
2. To assign the Slave VCU an identifiable name:
 - Select the Module Info Tab
 - Click the **Modify** button
 - Type the unit name and click **OK**. *Note: Up to 17 alpha-numeric characters are allowed.*

5 VAP Installation and Provisioning

This section provides a description of the VE Access Pods (VAPs) installation, verification, and monitoring procedures.

5.1 VAP Installation

The VAPs installation procedure consists of connecting each VAP to the Ethernet jack in the appropriate location to provide optimal coverage (See sections 3.4).

It is recommended to install the VAPs in places located high up so as to maximize the provided coverage per VAP.

Note: Mounting a VAP beneath a desk or in another secluded location (e.g. office corner) decreases the effective coverage of the VAP increasing the need for a higher number of VAPs to cover the same area.

There are three main types of VAP mounting installations:

- Desk Mount – Used for VAPs mounted on locations such as desks, cubical walls, and filing cabinets. (See section 5.2.2).
- Wall Mount – Used for VAPs mounted on walls (recommended high up). (See section 5.2.3).
- Ceiling Mount – Used for VAPs to be installed in the ceiling. There are two types of ceiling mount installations:
 - Horizontal
 - Vertical –See 5.4.

The LTE VAP is provided with the Desk/Wall mount kit, which also includes the RJ-45 cable for connecting the VAP to the Ethernet jacks. (See section 5.2.1). If the VAP is to be installed on the ceiling then an additional kit is provided, depending on whether the installation is horizontal (See section 5.3.1) or vertical (See section 5.4.1).

VAP Installation Considerations

- Placing units in an open area.
- Availability of CAT-5e/6 infrastructure.
- The VAPs plug into standard (RJ-45) Ethernet connection jacks.
- If the jack being used is already connected to Ethernet switch. (See sections 3.4.2 and 4.3).
- Aesthetics of the VAP location.





5.2 Desk and Wall Mount VAP Installations

5.2.1 VAP Kit Contents

The LTE 700 MHz VE Access Pod (VAP) Kit includes:

Note: The provided VAP kit includes two mounting options: Desk Mount and Wall Mount. See sections 0 and 5.4. Ceiling Mount kits can be ordered separately.

Table 10: Desk and Wall Mount VAP Kit

Kit Items	Unit
VE Access Pod (VAPs)	
Wall Mount Adaptor (Features double sided sticky tape located on rear for fast installation.)	 <p style="text-align: center;">Front Rear – showing tape</p>
Desk Mount Adaptor	
(8) Screws: <ul style="list-style-type: none"> ○ (4) Short Screws – Used to secure adaptor to pod ○ (4) Longer Screws – Used to secure wall mount adaptor to the wall (“anti-theft” installation) 	 <p style="text-align: center;">Long screws Short screws</p>
RJ-45 Jumper Cable	

5.2.2 Desk Mount Installation

Note: All components (adaptor, screws, and cables) are included in the VAP Kit.

- Place the VAP on the Desk Mount.
- Secure the Desk Mount adaptor to the VE Access Pod using the (4) short screws.
- Connect the VAPs RJ-45 **VCU** connector to the Ethernet jack leading to the **VCU** via RJ-45 cable supplied with VAP.
- Place the VAP on a flat surface according to the planned location.
- Plug the other end of the cable into the VCU's (RJ-45) Ethernet jack.
- When using an external antenna, connect the **Ext. Antenna** SMA connector(s) to the external antenna(s). (*Note: External antenna is enabled by default.*)

Note: The maximum external antenna gain should not exceed 10 dBi.

- Verify that the VAP receives power and connects to the VCU via the LEDs on the unit (both the GREEN LED and the BLUE LED should be lit).

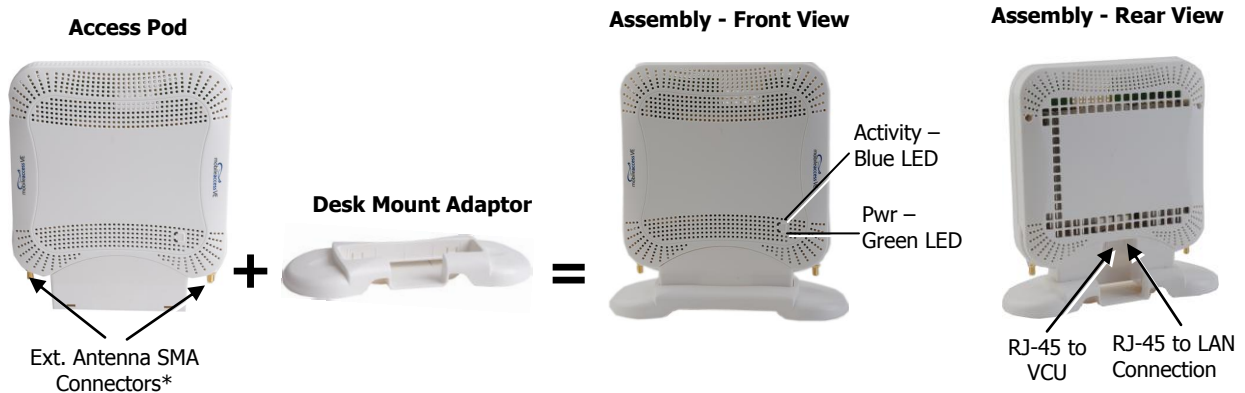

5.2.3 Wall Mount Installation

Note: All components (adaptor, screws, and cables) are included in the VAP Kit.

- Attach the VAP's wall mount adaptor to the wall in the planned location, using the double sided sticky tape located on the rear or secure it using the longer screws.
- Place the VAP on the Wall Mount.
- Secure the Wall Mount adaptor to the VE Access Pod using the (4) short screws.



- Connect the VAPs RJ-45 VCU connector to the Ethernet jack leading to the **VCU** (via RJ-45 cable supplied with VAP).
- Plug the other end of the cable into the VCUs (RJ-45) Ethernet jack.
- Connect the **Ext. Antenna** SMA connector(s) to the external antenna(s). (Note: External antenna is enabled by default).

Note: The maximum external antenna gain should not exceed 10 dBi.

- Verify that the VAP receives power and connects to the VCU via the LEDs on the unit (both the GREEN LED and the BLUE LED should be lit).

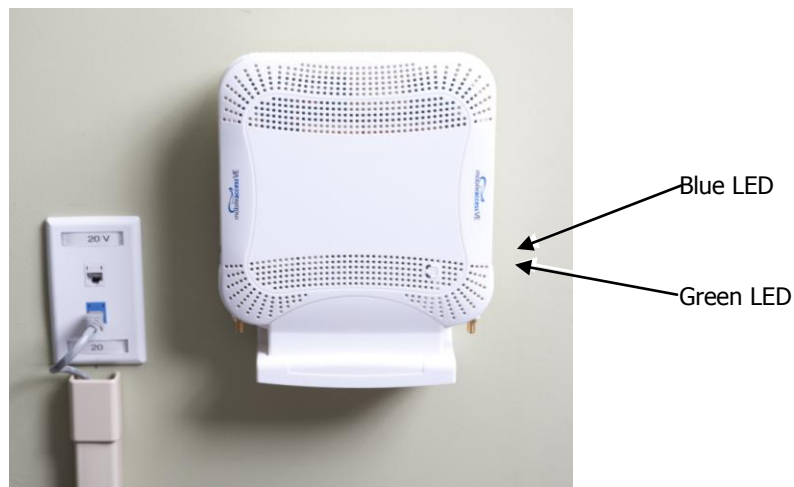

Figure 5-1. VAP Mounted on Wall

5.3 Horizontal Ceiling Mount VAP Installations

Note: The VAP and required RJ-45 cable are supplied in the provided VE LTE VAP kit (See section 5.2.1).



The Horizontal installation procedure varies depending on the type of ceiling:

- Lowered ceilings (See section 5.3.2).
- Concrete/Wood ceilings (See section 5.3.3).

5.3.1 VAP Kit Contents

Please verify that the VAP Ceiling Mount Installation kit (P/N AK-VAP-CEILING-MT-H) includes the items listed below.

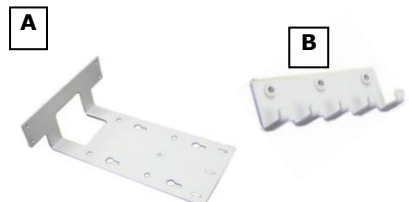
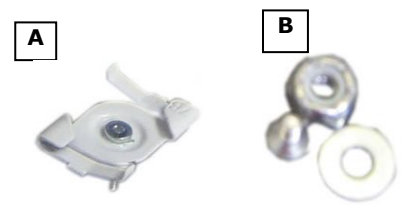
Table 11: Horizontal Ceiling Mount VAP Kit

Kit Items	Description	Unit
Mounting Brackets	A) Ceiling Bracket B) Locke Bracket	
"Twist on" Track Light Clip Assembly	Used for installation on lowered ceilings. A) Track Light Clip B) Screw, Bolt, and Washer	
(3) Flat Head Screws 100', 4/40 x 1/4 [NEROSTA]	Used for assembling brackets together	
(4) Self Screws 3dim L=8 ,Flat HD 90 [Steel zinc]	Used to secure bracket assembly to VAP	

5.3.2 Lowered Ceiling Installation

To Install VAP in Lowered Ceiling

1. *Loosely* assemble the two brackets (Ceiling and Locke) using the (3) Flat Head Screws. *(Note: The assembly will be secured at a later stage.)*
2. Assemble the Track Light Clip to the Ceiling Bracket (top side) using the provided washer and bolt.

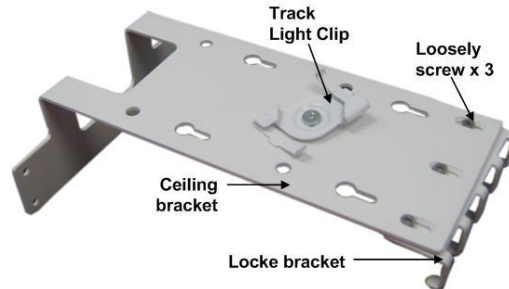

3. Hook the assembly onto the VAP rear panel grid and fit to the bottom of VAP.



4. Secure the assembled brackets to the bottom of the VAP using the (4) Self Screws.
5. Adjust the bracket assembly to firmly fit the VAP and tighten the (3) screws securing the assembly.

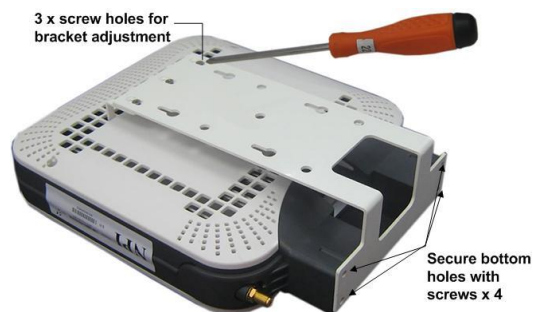

6. Mount the VAP on the lowered ceiling as follows:
 - Enlarge large flanges over opposite sides of T-bar. *Note: Apply slight pressure as Twist Clip is made of spring steel.*

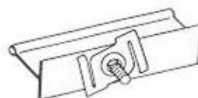

- Twist flanges clockwise until small flanges snap over edges. The Twist Clip is now in position.

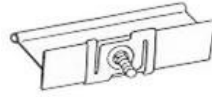

- Place stud through 1/2" knock-out. Use 4WN washer-nut combination and tighten securely.



Figure 5-2. VAP Installed Horizontally on Ceiling

7. Continue to section 5.3.4 for connections and verifying normal operation.

5.3.3 Concrete/Wood Ceiling Installation

To Install VAP in Lowered Ceiling

1. Mark the location of the (4) screws on the ceiling according to the (4) larger holes on the bracket assembly.
2. Drill the screws in to the marked locations on the ceiling.

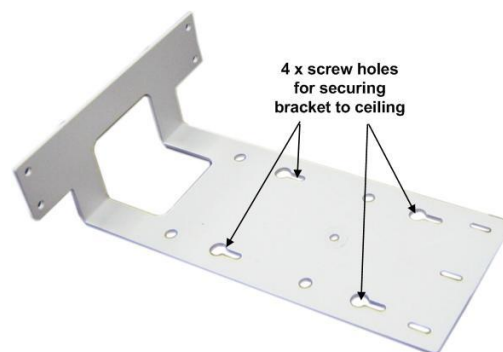

3. Align the three screw holes of each of the brackets (Ceiling and Locke) as shown in the adjacent figure and using the Flat Head Screws, *loosely* assemble the brackets. *Note: To be adjusted at a later stage.*

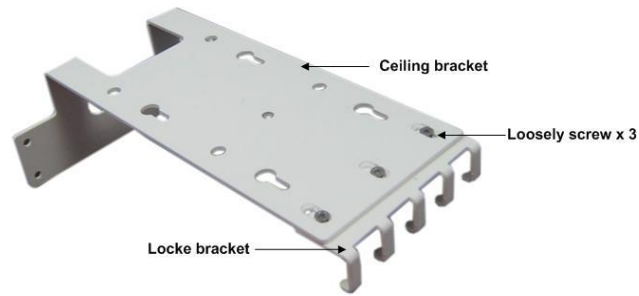

4. Fit the assembled brackets on to the VAP by inserting the (5) hooks in corresponding top rear grid of the VAP and fit the other side on to the underside of the VAP.



5. Secure the assembled brackets to the bottom of the VAP using the (4) Self Screws.
6. Adjust the bracket to the VAP and tighten the assembly screws.
7. Hang the VAP using the (4) larger screw holes, on to the (4) screws located on the ceiling.

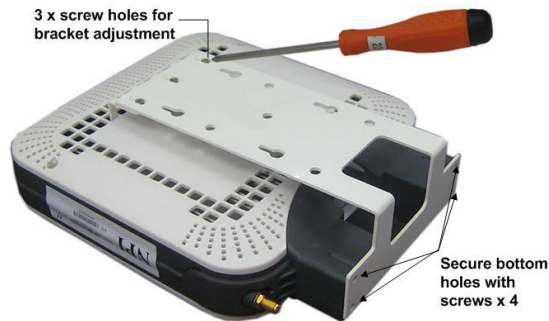

8. Continue to section 5.3.4 for connections and verifying normal operation.

5.3.4 Connecting VAP and Verifying Normal Operation

After the VAP has been mounted on the ceiling continue as follows:

- Connect the VAPs RJ-45 VCU connector to the Ethernet jack leading to the **VCU** via RJ-45 cable supplied with VAP.
- Connect the **Ext. Antenna** SMA connector(s) to the external antennas. (*Note: External antenna is enabled by default.*)

Note: The maximum external antenna gain should not exceed 10 dBi.

- Verify that the VAP receives power and connects to the VCU via the LEDs on the unit, both the GREEN LED and the BLUE LED should be lit.

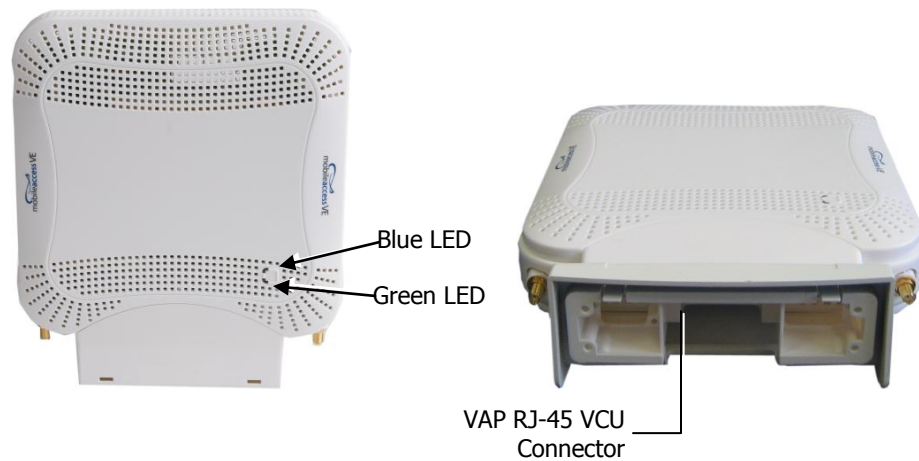

5.4 Vertical Ceiling Mount VAP Installations

Note: The VAP and required RJ-45 cable are supplied in the provided VE LTE VAP kit (See section 5.2.1).



The Vertical installation procedure varies depending on the type of ceiling:

- Lowered ceilings (See section 5.4.2).
- Concrete/Wood ceilings (See section 5.4.3).

5.4.1 VAP Kit Contents

Please verify that the VAP Ceiling Mount Installation kit (P/N AK-VAP-CEILING-MT-V) includes the items listed below.

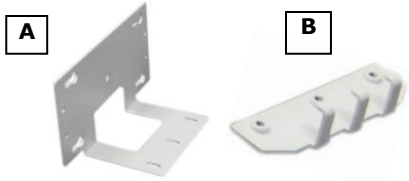
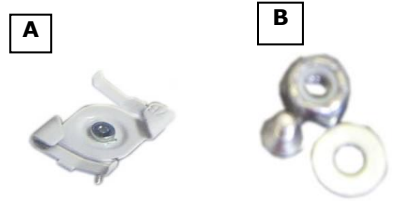
Table 12: Vertical Mount VAP Kit

Kit Items	Description	Unit
Mounting Brackets	A) Ceiling Bracket B) Locke Bracket	
"Twist on" Track Light Clip Assembly	A) Track Light Clip B) Screw, Bolt, and Washer	
(3) Flat Head Screws 100', 4/40 x 1/4 [NEROSTA]	Used for assembling brackets together	
(4) Self Screws 3dim L=8, Flat HD 90' [Steel zinc]	Used to secure bracket assembly to VAP	

5.4.2 Lowered Ceiling Installation

To Install VAP in Lowered Ceiling

1. *Loosely* assemble the two brackets using the (3) Flat Head Screws. (*Note: The assembly will be secured at a later stage.*)
2. Assemble the Track Light Clip to the Large Horizontal Bracket (top side) using the provided washer and bolt.

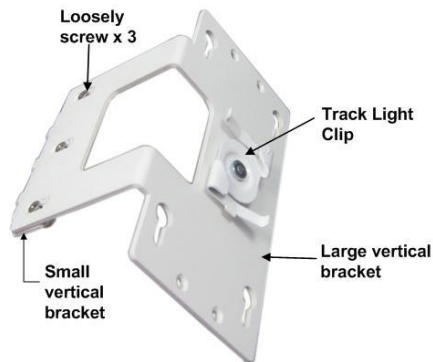

3. Hook the assembly onto the VAP rear panel bottom grid and fit to underside of the VAP.
4. Secure the assembled brackets to the bottom of the VAP using the (4) Self Screws.

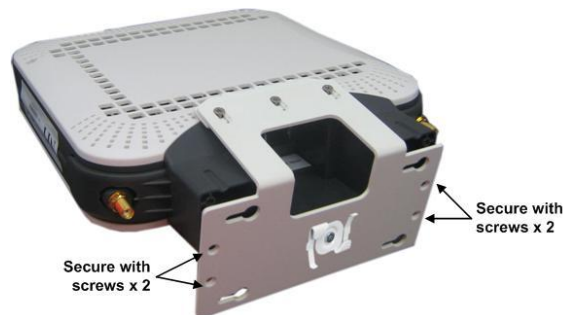

5. Adjust the bracket to firmly fit the VAP and tighten the (3) bracket assembly screws.

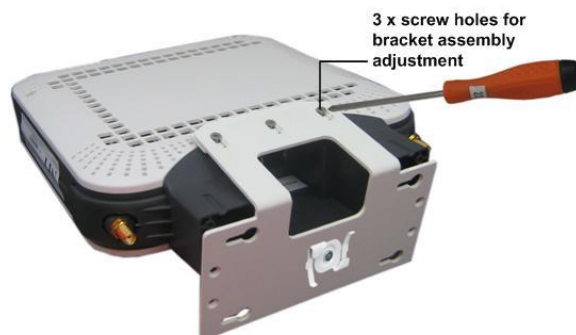

6. Mount the VAP on the lowered ceiling as follows:

- Enlarge large flanges over opposite sides of T-bar. Note: Apply slight pressure as Twist Clip is made of spring steel.

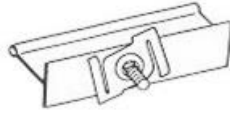

- Twist flanges clockwise until small flanges snap over edges. The Twist Clip is now in position.

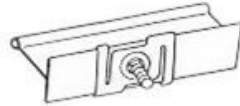

- Place stud through 1/2" knock-out. Use 4WN washer-nut combination and tighten securely.



Figure 5-3. VAP Mounted Vertically on Ceiling

7. Continue to section 5.4.4 for connections and verifying normal operation.

5.4.3 Concrete/Wood Ceiling Installation

To Install VAP in Lowered Ceiling

1. Mark the location of the (4) screws on the ceiling according to the (4) larger holes on the bracket assembly.
2. Drill the screws in to the marked locations on the ceiling.

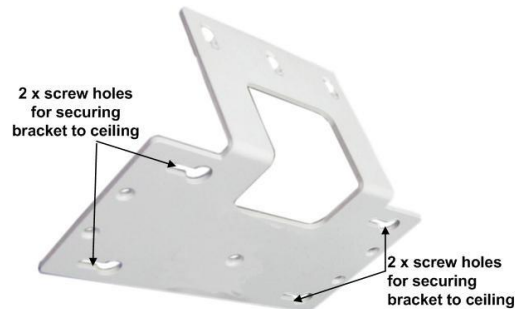

3. Align the three screw holes of each of the brackets (Ceiling and Locke) as shown in the adjacent figure and using the Flat Head Screws, *loosely* assemble the brackets. *Note: To be adjusted at a later stage.*

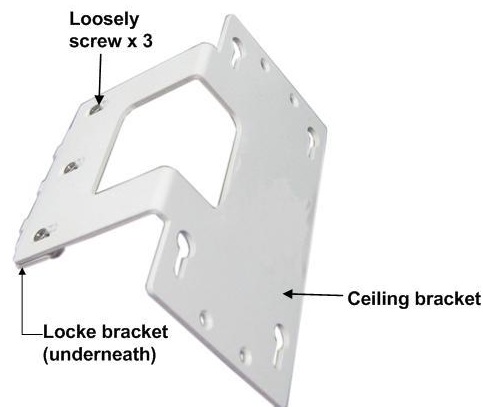

4. Fit the assembled brackets on to the VAP by inserting the (3) hooks in corresponding bottom rear grid of the VAP and fit the other side on to the underside of the VAP.
5. Secure to the underside of the VAP using the (4) Self Screws.

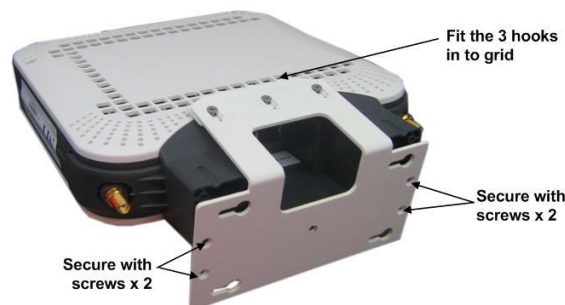

6. Tightly adjust the bracket to the VAP and secure the bracket assembly.
7. Hang the VAP on to the (4) screws located on the ceiling, and secure the screws.

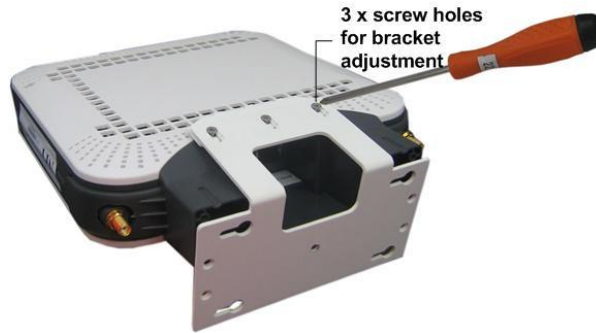

8. Hang the VAP using the (4) larger screw holes on to the (4) screws located on the ceiling.

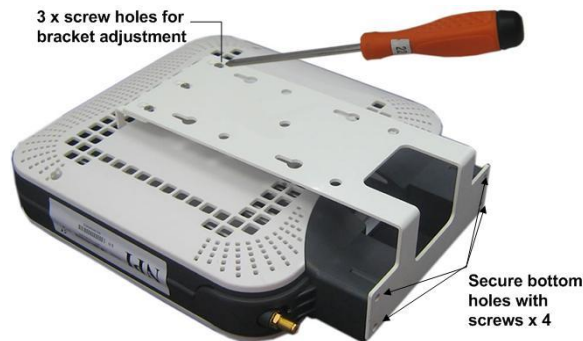

9. Continue to section 5.4.4 for connections and verifying normal operation.

5.4.4 Connecting VAP and Verifying Normal Operation

After the VAP has been mounted on the ceiling continue as follows:

- Connect the VAPs RJ-45 **VCU** connector to the Ethernet jack leading to the **VCU** via RJ-45 cable supplied with VAP.
- When using an external antenna, connect the **Ext. Antenna** SMA connector(s) to the external antenna(s). **This option must be SW configured via the web GUI.** (*Note: Internal antenna is enabled by default.*)

Note: The maximum external antenna gain should not exceed 10 dBi.

- Verify that the VAP receives power and connects to the VCU via the LEDs on the unit, both the GREEN LED and the BLUE LED should be lit.

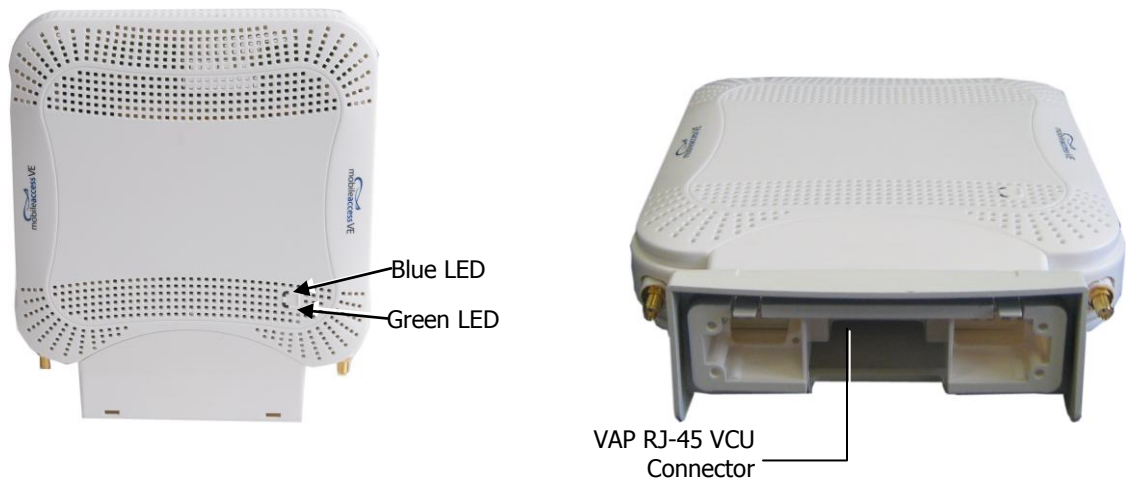

5.5 Verifying VAP Coverage Area

Verify coverage in the areas, adding and moving VAPs for optimal coverage according to the principles described in 3.3.

5.6 Naming the VAPs, Verifying Connections and Monitoring

5.7 Provisioning the VAPs

Note: This section provides only the information required for provisioning the VAPs. For a full description of the VAP configuration options, refer to Chapter 8.

The VAPs are auto-discovered by the VCU and can be monitored via a remote or a local connection to the Master VCU. The VAPs are auto-configured by the VCU without user intervention, no configuration procedure is required. However, if you wish, you may assign each VAP an identifiable name corresponding to its physical location.

5.7.1 Verifying Normal VAP Operation

Use the RF Parameters and Module Info sub-tabs to review the VAP information and status.

1. If a session is not already open to the MobileAccessVE Web GUI application, open a session to the Master VCU according to section 4.4.2.
2. Select a VAP from the Network Topology Tree.

Each VAP has a default name showing the number of the Slave VCU port to which the VAP is connected.

3. To verify normal operation of the VAP:
 - In the Network Topology Tree, under the Control Unit, verify that an LED is displayed (either RED or GREEN) for each connected VAP.

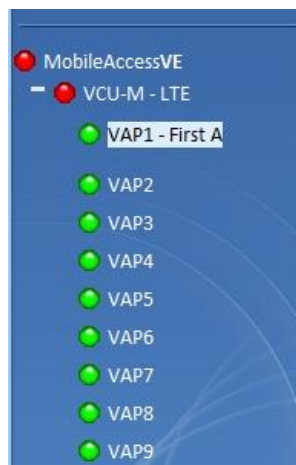

- If the VAP LED is **RED**, select the VAP from the network topology tree then select the **Config** tab. Refer to the **Alarms** tab work area. Use the displayed alarms to identify the problems.



Notes:

1. VAP alarm mask is saved in the VCU, associated with the port to which the VAP is connected. In case you replace the VAP, the newly installed VAP will automatically be set with same alarm mask.
2. For more information on the VAP Alarms, refer to section 8.2.

5.7.2 Naming the VAP

To assign the VAP an identifiable name:

- Open the Config **Module info** tab.

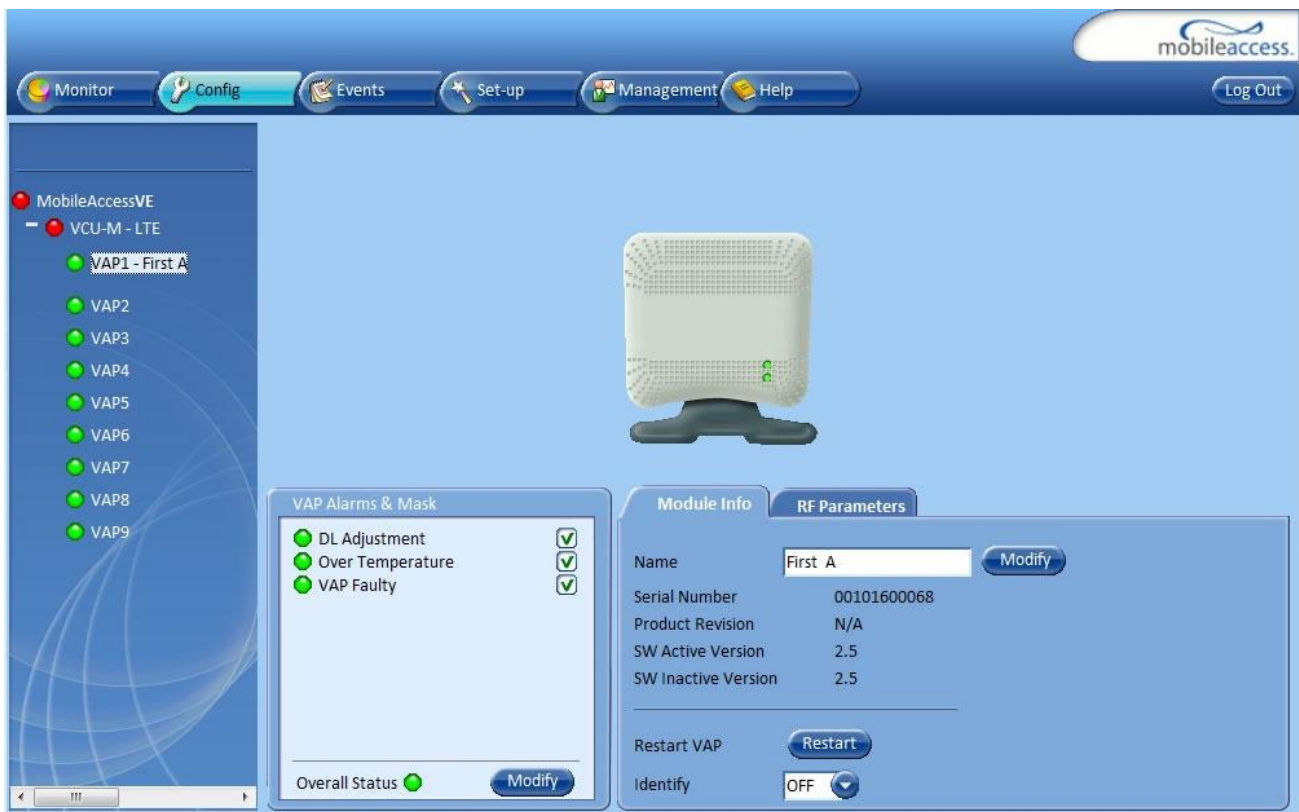

- Click the **Modify** button.
- Type the unit name and click **OK**. (*Note: Up to 17 characters are allowed.*)

6 Navigating the Web Access Application

The MobileAccess**VE** Web management application is accessed through any standard web browser connected to the Master VCU via a network within the same subnet as the Master VCU or a different subnet which is routable.

6.1 Opening a Session and Authentication Levels

After the initial configuration, as explained in 4.4.1, the MobileAccess**VE** system can be accessed via the network.

To Access the System:

1. Open a web browser. In the address bar type the Master VCU's IP address as you set it in the Master VCU configuration operation. (See section 4.4.1).



2. The Login pane appears.



Enter your User Name and password. The following authentication levels are available:

Level	Default Password	Access
operator	oper	This user has Read Only access.
engineer	eng	This user has access to basic configuration options.
admin	ma98	This user has Field Engineer permissions, in addition to access to changing passwords.

6.2 About the MobileAccessVE Web Access Window

The MobileAccessVE Web window includes six main tabs that provide access to the applications' main options. Here the Config tab is displayed by default.

Note: The Monitor, Events, Setup, and Help tab are future options.

The appearance of the each screen varies according to the tab displayed. The Main Menu Bar tabs are:

- Config(uration) – Displayed by default upon login. Provides the selected units' configuration parameters and alarms
- Management - Provides upgrade, IP configuration and security options

Both of these tabs are described in detail in the following sections



6.3 Configuration Tab

The **Configuration** tab provides the general information and service RF parameters for configuration of the units appearing in the Network Topology tree.

To Access a VCU Configuration Tab

On the left hand side of the window select a Master VCU/Slave VCU from the network topology tree. Select the **Configuration** tab from the menu-bar. The information and parameters displayed in the Configuration sub-tabs vary depending on whether a VCU or VAP is selected in the topology tree.

The Configuration tab is divided in to three main areas:

- Network Topology Tree – Displays the system units (Master VCU, Slave VCUs, and VAPs) and their status.
- Display Area – Displays the icon of the selected unit including the LED statuses.
- Work Area – Displays the Module Info, alarms, and RF tabs corresponding to the unit selected in the topology tree (Master VCU, Slave VCU or VAP).

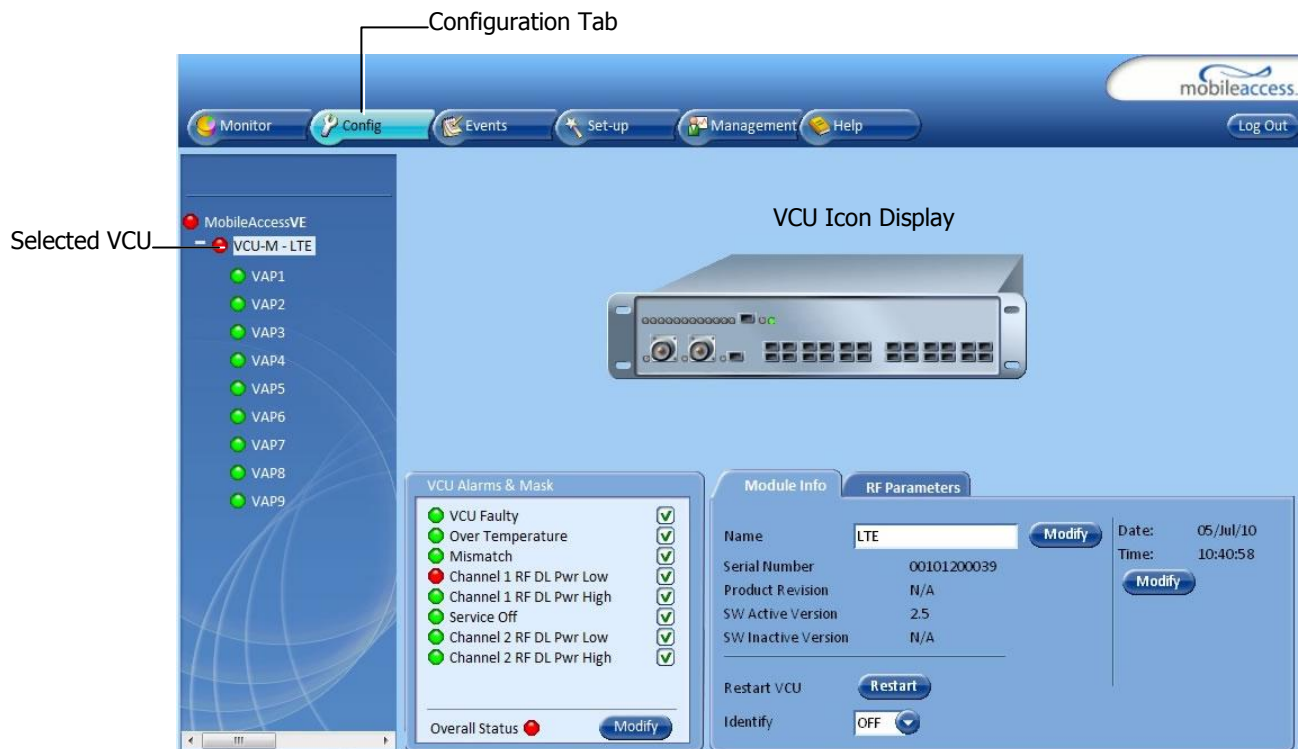

6.3.1 Network Topology Tree

The Configuration Network Topology Tree appears on the left hand side when the **Config** tab is selected. Connected Slave VCUs and VAPs are automatically detected and displayed in the topology. The MobileAccess**VE** Web Access Application includes a Baseline feature providing an indication on network elements (VCUs or VAPs), which were disconnected from the VE network. Connected Slave VCUs, and VAPs are automatically added to the Baseline upon detection, and will appear in the topology as grayed out in case they get disconnected. The network elements are displayed in two levels:

- First Level – Up to 12 VCUs
- Second Level – Up to 12 VAPs connected to each VCU

*Note: The root is MobileAccess**VE**.*

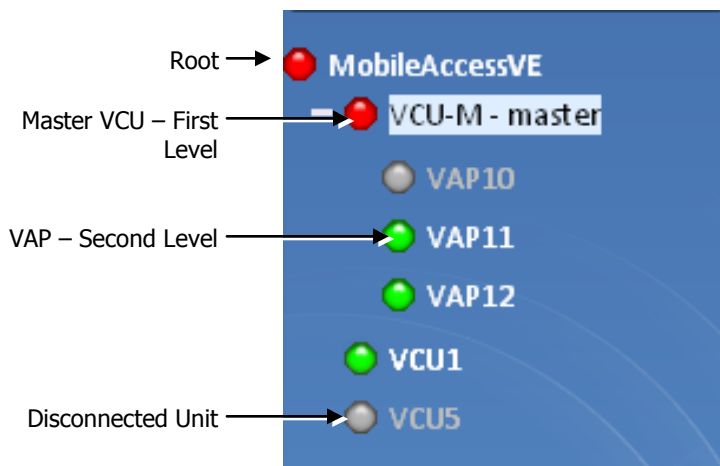

Each unit is assigned a **Type Px-name**:

- Type – VCU-M, VCU or VAP (for Master VCU, Slave VCU or VE Access Pod)
- Px - VCU port number
- Name – User defined

Each unit is displayed with a colored bullet that indicates its' status:

Color	Indicates
Green	OK
Red	Alarm Condition
Gray	Disconnected unit (e.g. faulty connection)

The root (the entire MobileAccess**VE** site) is also associated with a colored bullet that indicates the overall status of the deployment:

Color	Indicates
Green	OK
Red	Alarm Condition in one or more VCUs or VAPs

6.3.1.1 **Removing Network Element from Baseline**

The Baseline automatically detects the connected units (VCUs and VAPs) and when for some reason a unit is disconnected or the connection is no longer detected it will not disappear from the topology but will appear in gray.

In order to remove a unit from the baseline so that it no longer appears in the network topology, it must be done via the GUI from either the Topology Tree or unit icon.

To Remove a Unit from the Baseline

1. Click on the unit in the Topology Tree or on the unit icon (for example, VAP). The following dialog appears:

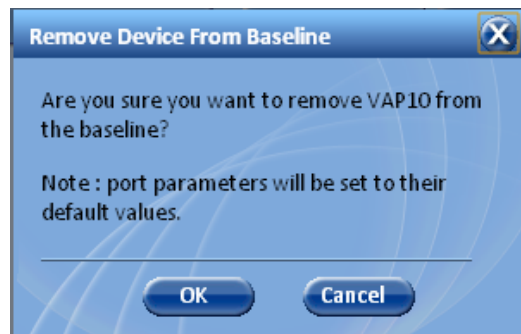

2. Click **OK**. The unit will no longer be displayed in the Network Topology Tree.

6.3.2 Configuration Display Area

When selecting an element (Master VCU/Slave VCU or VAP) in the network topology tree, an icon representing the unit is displayed in the Configuration tab display area.



6.4 Management Tab

The Management tab provides user administrative management options and includes the sub-menu tabs:

- Firmware – Used for upgrading/downgrading SW to VCU.
- Distribute – Used for distributing the upgrade/downgrade SW files to the VAPs.
- Security – Used for changing user passwords.
- SNMP Config – Used for defining the SNMP communities and trap destinations.
- IP Settings – Used for viewing and modifying the network parameters.
- Sys(tem) Log – N/A

The following figure shows the Management screen with the menu options on left.



7 VCU Monitoring and Configuration

7.1 Viewing VCU General Information

The VCUs general information, such as unit name and SW versions, can be viewed in the Config **Module Info** sub-tab.

The tab includes two additional options:

- Identify Button - Enabling this option enables finding the physical location of the selected element (See section 10.1). When this option is set to ON, the LEDs on the corresponding VCU flickers.
- Reset Button - SW reset of the unit

To View VCU General Information

- Click the Config tab from the main menu and select the VCU from the network topology tree. The **Module Info** sub-tab is displayed by default.

The screenshot shows the MobileAccessVE web interface. The top navigation bar includes Monitor, Config, Events, Set-up, Management, and Help. The left sidebar shows a network topology tree with MobileAccessVE and VCU-M - LTE. The main content area displays a VCU hardware image. Below the image are two panels: 'VCU Alarms & Mask' and 'Module Info'. The 'VCU Alarms & Mask' panel lists various alarms with checkboxes, and the 'Module Info' panel shows details like Name (LTE), Serial Number (00101200039), Product Revision (N/A), SW Active Version (2.5), and SW Inactive Version (N/A). It also includes buttons for Restart VCU and Identify.

VCU Alarms & Mask	
<input checked="" type="checkbox"/> VCU Faulty	<input checked="" type="checkbox"/>
<input checked="" type="checkbox"/> Over Temperature	<input checked="" type="checkbox"/>
<input checked="" type="checkbox"/> Mismatch	<input checked="" type="checkbox"/>
<input checked="" type="checkbox"/> Channel 1 RF DL Pwr Low	<input checked="" type="checkbox"/>
<input checked="" type="checkbox"/> Channel 1 RF DL Pwr High	<input checked="" type="checkbox"/>
<input checked="" type="checkbox"/> Service Off	<input checked="" type="checkbox"/>
<input checked="" type="checkbox"/> Channel 2 RF DL Pwr Low	<input checked="" type="checkbox"/>
<input checked="" type="checkbox"/> Channel 2 RF DL Pwr High	<input checked="" type="checkbox"/>

Module Info	
Name	LTE <input type="button" value="Modify"/>
Serial Number	00101200039
Product Revision	N/A
SW Active Version	2.5
SW Inactive Version	N/A
Restart VCU	<input type="button" value="Restart"/>
Identify	OFF <input type="button" value="Identify"/>

The following information is displayed:

Field	Description
Name	User defined name for system element (up to 17 characters)
Serial Number	Factory set ID number
Product Revision	Revision number of VCU/VAP
SW Active Version	Version of the SW currently being used to manage and monitor the system
SW Inactive Version	Version of other system SW version not in use
Identify Button	Enabling this option enables finding the physical location of the selected element (See section 10.1). When this option is set to ON, the LEDs on the corresponding VAP/VCU flickers.
Reset Button	SW reset of the unit

7.2 Viewing VCU Alarms

The alarms displayed in the Alarms tab correspond to the VCU (Master/Slave) selected in the topology tree. When a VCU element is selected in the topology tree, the Alarm tab displays the main alarms in the unit.

To View VCU Alarms

In the Topology Tree select the **Control Unit** (VCU) then click the **Config(uration)** tab in the menu bar located at the top of the window. Refer to the **VCU Alarms and Mask** sub tab.

The screenshot displays the MobileAccessVE configuration interface. The top navigation bar includes 'Monitor', 'Config' (circled in red), 'Events', 'Set-up', 'Management', and 'Help'. The left sidebar shows a topology tree with 'MobileAccessVE' expanded to 'VCU-M - LTE', listing VAP1 through VAP9. The main area features a VCU hardware image. Below it, the 'VCU Alarms & Mask' sub-tab (circled in red) is active, showing a list of alarms with checkboxes: VCU Faulty (checked), Over Temperature (checked), Mismatch (checked), Channel 1 RF DL Pwr Low (checked), Channel 1 RF DL Pwr High (checked), Service Off (checked), Channel 2 RF DL Pwr Low (checked), and Channel 2 RF DL Pwr High (checked). The 'Overall Status' indicator is red, and the 'Restart VCU' button is visible. The right panel shows 'Module Info' for 'LTE' with fields for Name, Serial Number, Product Revision, SW Active Version, and SW Inactive Version, along with 'Restart' and 'Identify' buttons.

If one or more alarms occur, the corresponding Status indicator will be illuminated in RED. If the VCU is OK and no fault occurs, the **Overall Status** indicator will illuminate GREEN.

Alarm	Description
VCU Faulty	Hardware fault detected in VCU
Over Temperature	Temperature of unit exceeds normal range
Mismatch	VCU service type is different from VAP service type
Channel 1/2 DL RF Pwr Low	DL RF Power is lower by 15dBm (or more) from the Max Expected Pin. <i>Note: Channel 2 alarm is not displayed when SISO service is used.</i>
Channel 1/2 DL RF Pwr High	Input power exceeds the maximum expected Pin by more than 3 dB. <i>Note: Channel 2 alarm is not displayed when SISO service is used.</i>
Service Off	User has disabled the service
Overall Status	Indicates Fault (RED) level if there are (unmasked) faults, or GREEN if there are no faults

7.3 Master VCU RF Parameters

Note: The RF parameters are not displayed for control units functioning as Slave VCUs.

To Access the Service RF Tab

Click the **Config** tab from the main menu bar and then select the Master control unit from the network topology and click the **RF Parameters** tab. The parameters displayed in RF Parameters tabs correspond to the selected element. The displayed parameters are similar for MIMO and SISO service modes, however in SISO mode only the *Channel 1 Pin* parameter is displayed.

The screenshot shows the MobileAccessVE configuration interface. The main menu bar at the top includes Monitor, Config (highlighted with a red circle), Events, Set-up, Management, and Help. The left sidebar shows a tree view of the network topology, with VCU-M-LTE selected. The main area displays a 3D model of the VCU hardware. Below the model, there are two panels: 'VCU Alarms & Mask' and 'Module Info'. The 'Module Info' panel has the 'RF Parameters' tab selected (highlighted with a red circle). The 'VCU Alarms & Mask' panel shows a list of alarms with checkboxes for masking, and the 'Overall Status' is shown as a red circle. The 'RF Parameters' panel shows the following settings:

Type	LTE-Band 13 (Upper C)
Service Mode	MIMO
DL CF	751.0 MHz
Max Exp Pin	0 dBm
UL System Gain	0 dB
Channel 1 Pin	LOW
Channel 2 Pin	LOW

The following table provides a description of the RF parameters displayed in the Service RF tabs.

Parameter	Description
Type	Set (read only) according to unit type (LTE)
Service Mode	Provides the service options: MIMO/SISO/Off. The selected option determines the displayed RF parameters.
DL CF*	Set (read only) center frequency (from BTS) according to LTE 700 MHz range - Band 13 (upper Block). The CF is the same for both UL and DL signals.
UL System Gain	Used for adjusting the UL system gain. Range: -15 dB to +5 dB
Max Exp Pin*	Maximum expected input power from the BTS. Used for adjustment procedure. Range: 0-33 dBm. User defined.
Channel 1 / Channel 2 Pin	Actual measured Pin (read only). In SISO mode only Channel 1 Pin is relevant.

* Required parameters to be provisioned by the user.

8 VAP Monitoring and Configuration

8.1 Viewing VAP General Information

The VAPs general information (such as unit name and SW versions) can be viewed in the Config **Module Info** sub-tab.

The tab includes two additional options:

- Identify Button - Enabling this option enables finding the physical location of the selected element. When this option is set to ON, the LEDs on the corresponding VAP flickers.
- Reset Button - SW reset of the unit.

To View VAP General Information

Click the Config tab in the main menu and select the VAP from the network topology tree. The **Module Info** sub-tab will be displayed by default.

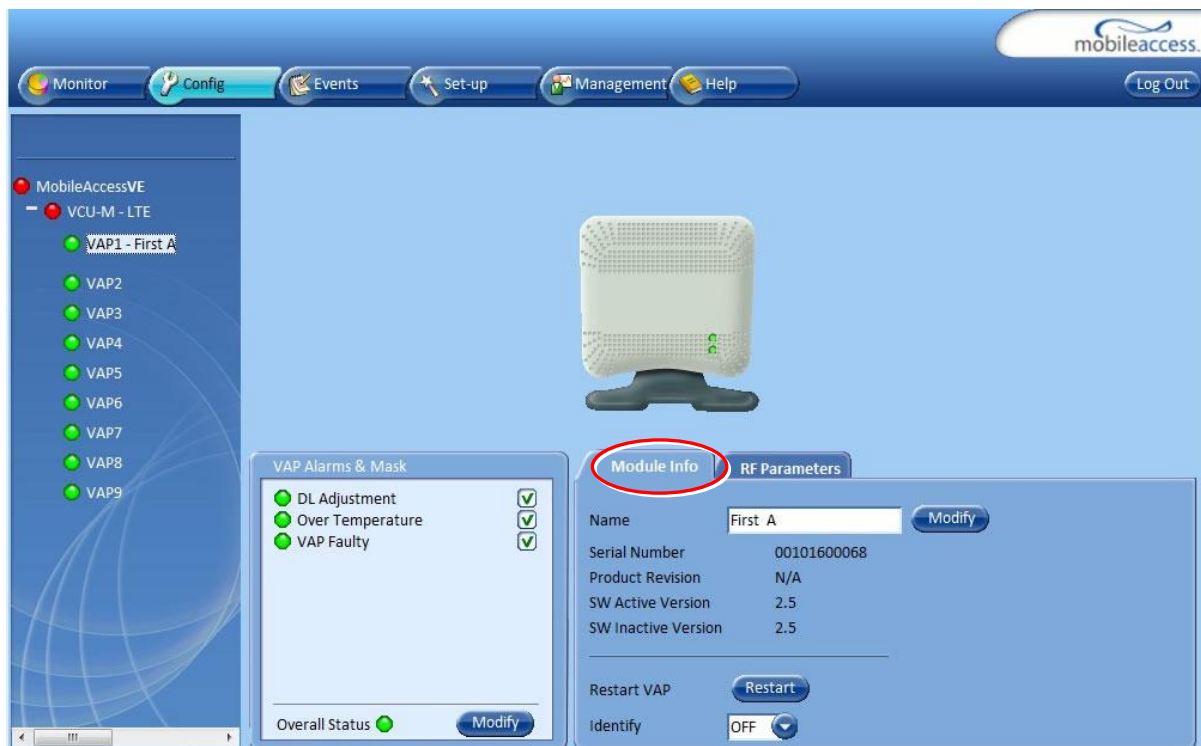

The following information is displayed:

Field	Description
Name	User defined name for system element (up to 17 characters)
Serial Number	Factory set ID number
Product Revision	Revision number of VCU/VAP
SW Active Version	Version of the SW currently being used to manage and monitor the system

Field	Description
SW Inactive Version	Version of other system SW version not in use
Identify Button	Enabling this option enables finding the physical location of the selected element (See section 10.1). When this option is set to ON, the LEDs on the corresponding Access POD/VCU flickers.
Reset Button	SW reset of the unit

Note: VAP Name is saved in the VCU associated to the port to which the VAP is connected. If you replace a VAP, the new one will be associated with the same name. If you do not want to keep that configuration of the replaced VAP, remove it from the topology baseline prior to connecting the new VAP.

8.2 Viewing VAP Alarms

When a VAP element is selected in the topology tree, the Alarm tab displays the main alarms in the unit.

To Access VAP Alarms Tab

Click the Config tab in the main menu and select the VAP from the network topology tree. Select the **VAP Alarms** sub tab.

The screenshot displays the MobileAccessVE configuration interface. The top navigation bar includes 'Monitor', 'Config' (highlighted with a red circle), 'Events', 'Set-up', 'Management', and 'Help'. The left sidebar shows a topology tree with 'MobileAccessVE' expanded to 'VCU-M - LTE', and 'VAP1 - First A' selected. The main area shows a VAP unit icon. Below the icon, the 'VAP Alarms & Mask' tab (also highlighted with a red circle) is active, displaying a list of alarms: 'DL Adjustment', 'Over Temperature', and 'VAP Faulty', each with a green status indicator and a checkmark. The 'Overall Status' is shown as green with a 'Modify' button. To the right, the 'Module Info' and 'RF Parameters' tabs are visible, showing configuration details for the VAP unit.

If one or more alarms occur, the corresponding Status indicator will be illuminated in RED. If the VAP is OK and no fault occurs, the **Overall Status** indicator will show GREEN.

Alarm	Description
DL Adjustment	RED - Cable (between VCU to VAP) is too long (over 100m/300ft)
Over Temperature	RED - Temperature of unit exceeds normal range
VAP Faulty	RED - A fault has been detected in the VAP
Overall Status	Indicates Fault (RED) level or GREEN if there are no faults

Note: DL adjustment alarm is raised when a VAP is connected over a cable exceeding system cable length limitation. In such cases, the system continues to provide the wireless services, but you should check the coverage of the VAP (as output power may be degraded due to excess cable loss) and check the Ethernet connection (as Ethernet standard maximum cable length has probably been exceeded).

8.3 VAP RF Parameters

The VAP **RF Parameters** sub-tab provides the configurable RF parameters corresponding to the VAP element selected in the network topology tree. The displayed RF parameters are similar for both MIMO and SISO service modes (in SISO service mode only **Channel 1** parameters are displayed).

To View the VAP RF Parameters

Click the **Config** tab from the main menu bar and then select the VAP from the network topology and click the *RF Parameters* sub-tab. The parameters displayed in RF tab correspond to the selected element.

The screenshot displays the MobileAccessVE configuration interface. The top navigation bar includes 'Monitor', 'Config' (highlighted with a red circle), 'Events', 'Set-up', 'Management', and 'Help'. A 'Log Out' button is in the top right. On the left, a network topology tree shows 'MobileAccessVE' with sub-items 'VCU-M - LTE' and 'VAP1 - First A' (selected). Below the tree, a list of VAPs (VAP2 to VAP9) is shown. The main area features a 3D model of a VAP unit. At the bottom, two panels are visible: 'VAP Alarms & Mask' with checkboxes for 'DL Adjustment', 'Over Temperature', and 'VAP Faulty' (all checked), and 'Module Info' with a 'RF Parameters' sub-tab (highlighted with a red circle). The 'RF Parameters' panel shows settings for 'Type' (LTE-Band 13 (Upper C)), 'Channel 1 Antenna' (External), 'Channel 2 Antenna' (External), 'DL Pout Level' (Normal), 'Channel 1 DL Pout' (LOW), and 'Channel 2 DL Pout' (LOW). An 'Overall Status' indicator shows a green dot, and a 'Modify' button is at the bottom right.

The following table provides a description of the displayed VAP RF parameters (in SISO service mode, only **Channel 1** parameters are displayed).

Parameter	Description
Type	Set (Read Only) according to unit type (LTE)
Channel 1/ Channel 2 Antenna	External only (default).
DL Pout Level	Level of from BS side. Normal = output power will be at required (normal) level Low = output power will be attenuated by 5 dB less than the required level. This option can be used for smaller coverage areas that do not require the full power of the VAP for coverage.
Channel 1/ Channel 2 DL Pout	Measured output power. Normal output power is approximately 14dBm.

Note: VAP RF settings (Service Mode, DL Pout Level, Antenna) are saved in the VCU associated to the port to which the VAP is connected. If you replace a VAP, all parameters are automatically set to the new VAP. If you do not want to keep that configuration of the replaced VAP, remove it from the topology baseline prior to connecting the new VAP.

9 Administrative Operations

This chapter describes the following Administrative operations:

- Changing password
- IP configuration parameters
- SNMP Configuration parameters
- Unit software upgrade and software management procedures

9.1 Changing Password

The Management - Security tab provides password change options.

To Set the Application Password or Change an Existing Password

1. Select the **Security** option of the Management tab at the top of the window.



2. Click the **Modify** button beside the User Name whose password is being modified.
3. Enter the **New Password** and re-enter in the **Confirm New Password** field.
4. Click **OK**.

Note: Passwords can only be changed when connected as an administrator.

9.2 Retrieving VCU IP Address

The IP Recovery Tool enables viewing and/or changing the VCU IP address.

To Install IP Recovery Tool

1. Install the IP Recovery Tool application, which can be found on the Setup CD, on the computer to which the VCU is to be connected.
2. Double-click on the Recovery Tool Setup and follow the prompts. Standard installation procedure.

To Retrieve the VCU IP Address

1. Connect the computer, on which the Recovery Tool is installed, to the VCU RS-232 **Console** port located on the rear panel (See **Error! Reference source not found.**).
2. Run the IP Recovery Tool application from the computer Start menu.

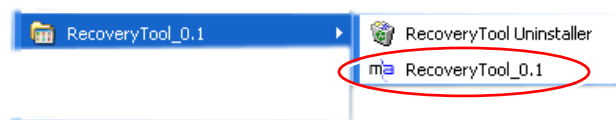

The Connection dialog appears.

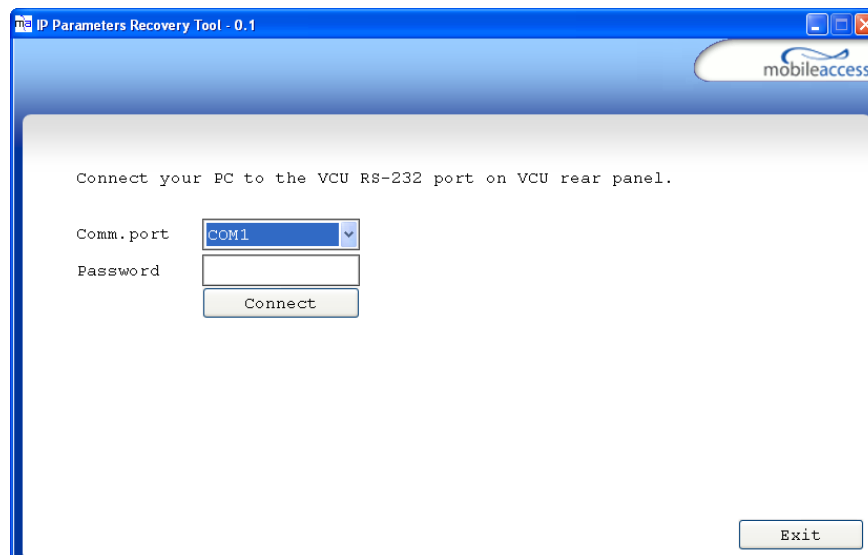

3. Select the **Comm. Port** corresponding to the connection on the computer.
4. Enter the password **Eng** and click **Connect**.

The current IP parameters dialog appears showing the VCI IP address.

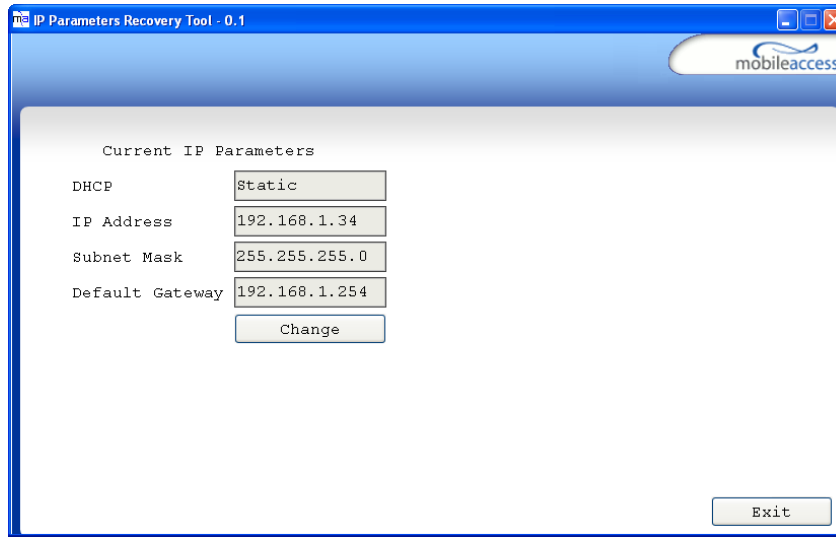

- To modify the current IP Parameters: click **Change**. The **Change IP Parameters** dialog appears:

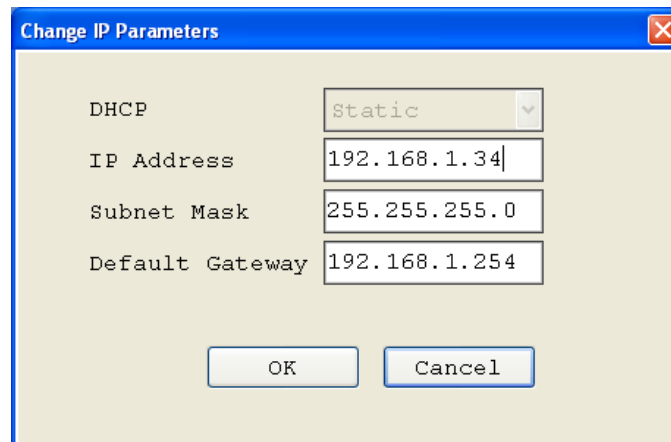

Enter the new parameter value and click **OK** and **Exit**.

9.3 IP Settings

The IP Settings tab is used for viewing and modifying the network parameters. The default parameter settings are as follows:

- IP Address: 192.168.1.1
- Subnet Mask: 255.255.255.0
- Default Gateway: 192.168.1.254

The screenshot shows the mobileaccess administrative interface. The top navigation bar includes Monitor, Config, Events, Set-up, Management, and Help. The left sidebar contains links for Firmware, Distribute, Security, SNMP Config, Sys Log, and IP Settings. The main content area displays the Lan Port configuration page with the following settings:

Lan Port	
DHCP	None
IP Address	192.168.1.1
Subnet Mask	255.255.255.0
Default Gateway	192.168.1.254
MAC Address	00:26:6D:00:09:62

A **Modify** button is located below the MAC Address field. An arrow points to this button with the text: Click **Modify** button to change settings.

9.4 SNMP Configuration Parameters

The SNMP Config tab is used for defining the SNMP communities in which the devices and management station belongs and to where the traps are sent. The SNMP default communities are:

- Read - public
- Write - private

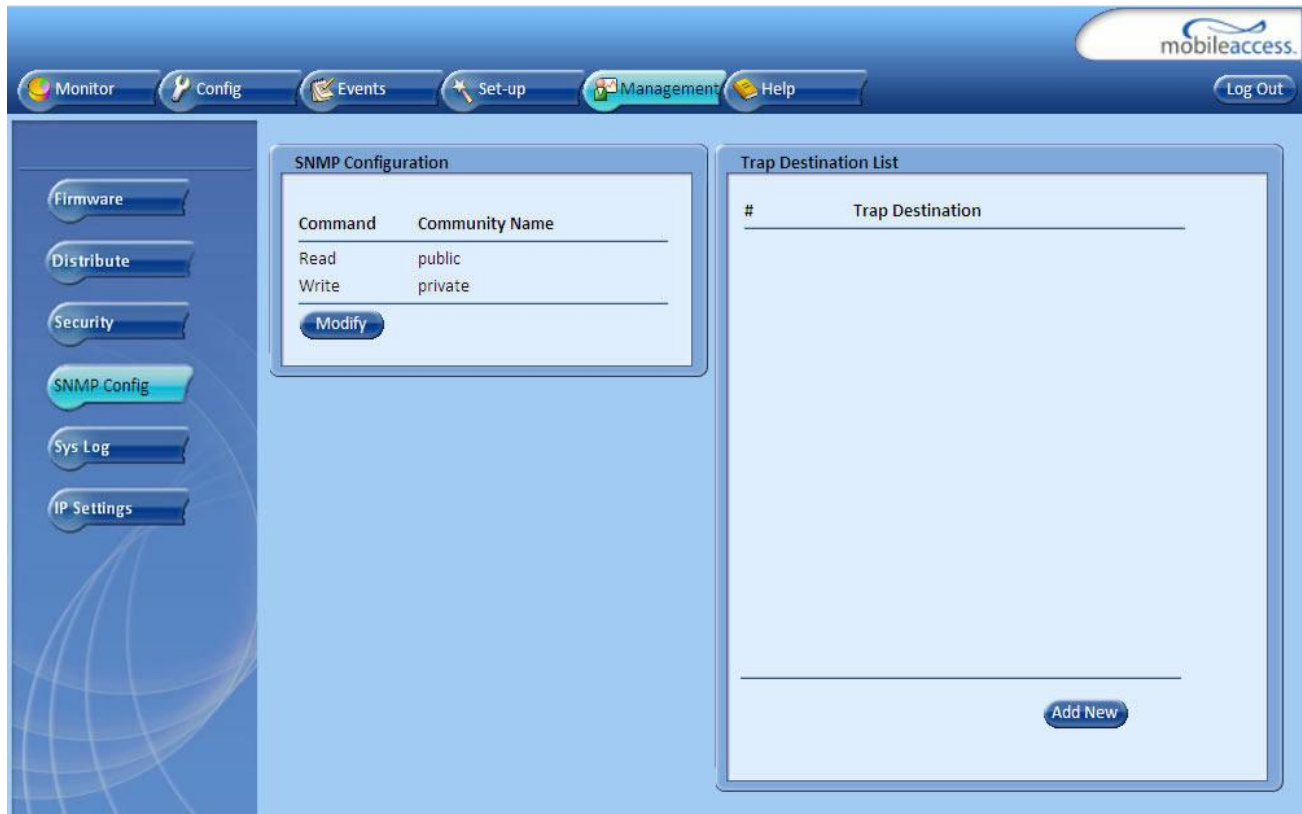

- The Community Names can be modified by clicking the **Modify** button in the SNMP Configuration display area.
- Additional Trap Destinations can be added by clicking the **Add New** button in the Trap Destination List display area:

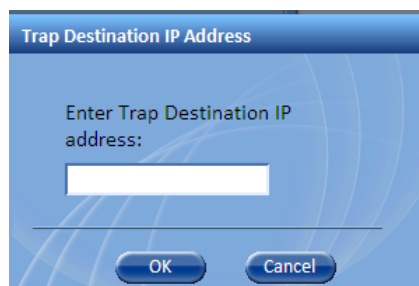

9.5 Upgrading (or Downgrading) VCU and VAP Software

Note: Before you start, verify that the VCU and VAPs upgrade files are located in an accessible location (i.e. on your computer).

The software for each VCU and its hosted VAPs can be upgraded through access to the VCU, where the **VAPs must be upgraded first** and only then the VCU.

Note: In installations with Slave VCUs, a session should be opened to the IP address of the Slave VCU in order to upgrade the SW of the Slave VCU and associated VAPs.

Two types of files are stored on the VCU and on individual VAPs: Active software on which the unit operates, and Standby software. The Active and Standby software can be swapped on each individual unit.

In addition, the VCU holds two software images for VAPs to be used in download process to VAPs.

The upgrade procedure consists of the following main phases:

1. Uploading the new VCU and VAP software to the host VCU.
2. Setting the new software as the Active software.
3. Downloading the new software to selected VAPs and activating it as the Active software on those VAPs.
4. Activating the new VCU software on the VCU.

The procedure is performed via two screens:

- Firmware Screen – Used to manage the software files stored on the VCU.
- Distribute Screen – Used to download the VAP software version to selected VAPs.

9.5.1 Upgrading the VAP SW

To Upgrade the VAPs SW Version:

1. Upload the VAP upgrade files from your storage location (i.e. computer) to the VCU as follows:
 - Click the **Management** menu tab and then select the **Firmware** sub-menu option located on the left side.
 - In the **Load New Firmware** display area, click the **Browse** button.
 - Browse for the file to be loaded from your computer location. The Download button appears and the progress bar will show the download status.

The screenshot shows the MobileAccessVE web GUI. The navigation menu on the left includes 'Firmware', 'Distribute', 'Security', 'SNMP Config', 'Sys Log', and 'IP Settings'. The 'Firmware' option is selected. The main content area displays 'VCU Version Banks' and 'VAP Version Banks' tables. The 'VCU Version Banks' table has columns for 'Active' and 'Standby', with 'SW Version' and 'SW Build' values. The 'VAP Version Banks' table has columns for 'Ready to download' and 'Standby', with 'SW Version' and 'SW Build' values. Below these tables is the 'Load New Firmware' section, which includes a 'File To Load' input field with a 'Browse' button and a 'Progress' bar showing 0%.

Load New Firmware Display Area

- After the download is complete, the downloaded SW version will appear in the Standby Bank column of the VAP display area.

Notes:

1. Locate the Firmware files on your local hard-drive prior to the download process.
2. During the download process DO NOT disconnect the Web GUI connection to the VCU.

2. To distribute the new software to selected VAPs:
 - Select the **Distribute** sub-menu option found on the left side.

The screenshot shows the Management Tab interface. On the left, the 'Distribute' sub-tab is selected. The main area displays the 'VAP Firmware Distribution Table' with the following data:

Selected	Device	Serial number	Active ver	Inactive ver	Progress	Status
<input type="checkbox"/>	VAP 1	00094500098	1.3	1.3		Connected
<input type="checkbox"/>	VAP 2	0009450008E	1.3	1.3		Connected
<input type="checkbox"/>	VAP 3	00094500096	1.3	1.3		Connected
<input type="checkbox"/>	VAP 4	000945000A6	1.3	1.3		Connected
<input type="checkbox"/>	VAP 5	000945000AD	1.3	1.3		Connected
<input type="checkbox"/>	VAP 6	000945000A4	1.3	1.3		Connected
<input type="checkbox"/>	VAP 7	000945000AA	1.3	1.3		Connected
<input type="checkbox"/>	VAP 8	000945000A5	1.3	1.3		Connected
<input type="checkbox"/>	VAP 9	0009450009F	1.3	1.3		Connected
<input type="checkbox"/>	VAP 10	000945000AB	1.3	1.3		Connected
<input type="checkbox"/>	VAP 11	0009450009A	1.3	1.3		Connected
<input type="checkbox"/>	VAP 12	000945000AE	1.3	1.3		Connected

3. Download the new version to the selected VAPs (Note: The downloaded version is stored as Inactive in the VAPs until a Swap procedure is performed.)
 - In the **VAP Distribute Table** display area, checkmark the VAPs to be upgraded. The Active and Inactive SW versions for each VAP are listed in the relevant columns.
 - Click the **Distribute** button to download the new software to the selected VAPs. The software is stored as the Inactive version in the VAPs.
 - Set the new software as the Active version in the selected VAPs by clicking the Swap button.
 - The VAP upgrade procedure is complete.

Notes:

1. As during the distribution process service may be interrupted, it is advised to perform the SW download and distribution in a maintenance window scheduled at off-peak hours (e.g. nights and/or weekends).
2. During the distribution process **DO NOT** perform configuration changes, connect or disconnect VAPs, and/or disconnect the web GUI.
3. After the distribution process is complete and swapping between VAP SW images, the VCU will restart automatically. After restart, the VAP firmware distribution table will be empty. Within several seconds it will re-populate as the VCU re-discovers connected VAPs.

9.5.2 Upgrading the VCU SW

To Upgrade the VCU SW Version:

1. Upload the VCU upgrade files from your storage location (i.e. computer) to the VCU as follows:
 - Click the **Management** menu tab and then select the **Firmware** sub-menu option found on the left side.

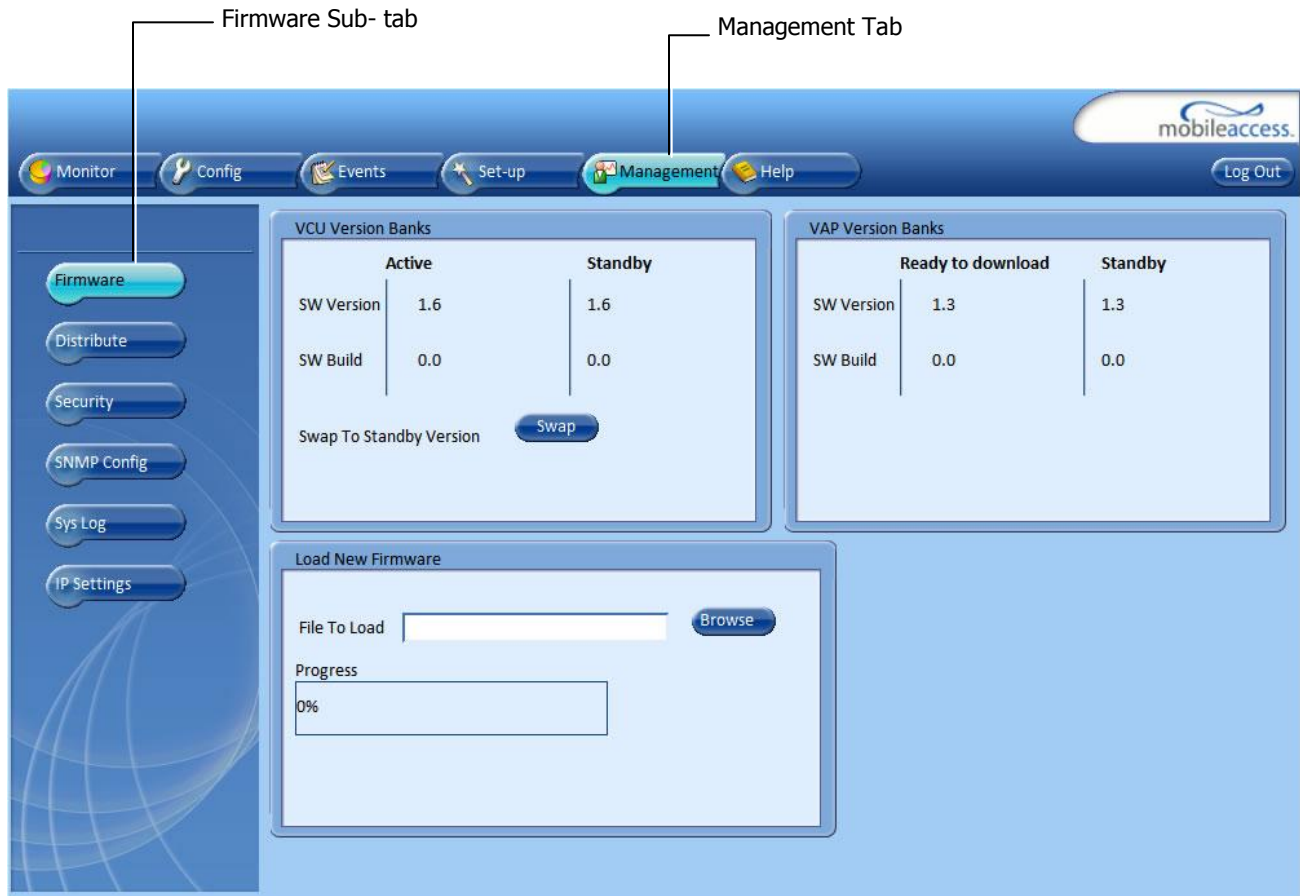

- In the **Load New Firmware** display area, click the **Browse** button.
 - Select the file to be loaded from your computer location. The Download button appears and the progress bar will show the download status.
 - After the download is complete the downloaded SW version will appear in the Standby Bank column of the VCU display area.
2. Define the downloaded version as the Active version (to be used for upgrade) as follows:
 - (In the VCU display area), click **Swap**. The downloaded version appears in the Active Bank column and the Controller is automatically restarted.
 - The VCU Upgrade procedure is complete.

10 Troubleshooting

10.1 Finding a Specific VAP in the Building

It is recommended to assign each VAP an identifiable name corresponding to its physical location, as explained in section 5.6. If a name was not configured, or for some other reason a specific VAP cannot be physically located, identify the VAP according to the instructions in the following example.

To Locate a VAP

1. Select the **Config** tab from the main menu bar and then select the VAP to be located from the topology tree.

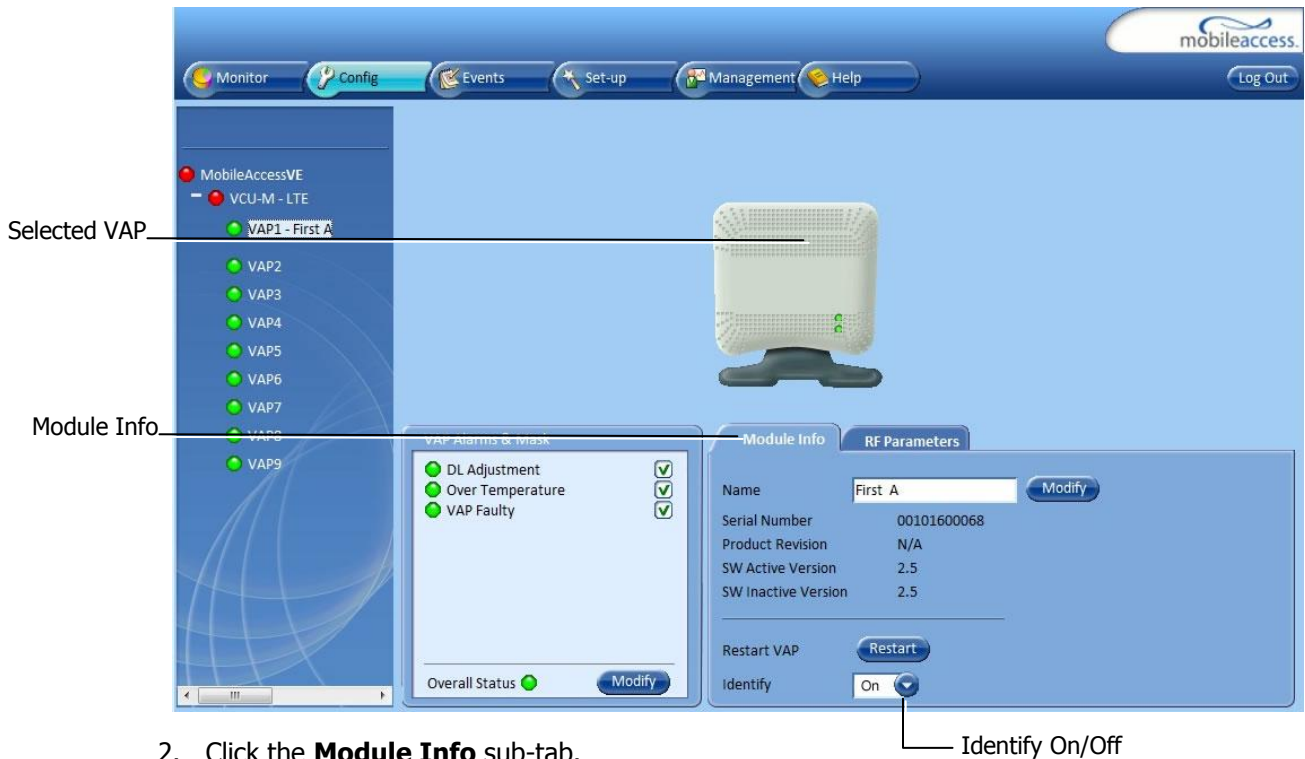

2. Click the **Module Info** sub-tab.

3. Set **Identify** to **ON**. The Activity LED (Blue) on the corresponding Access Pod will start blinking fast. (You will need to physically locate the VAP to see the blinking LED).

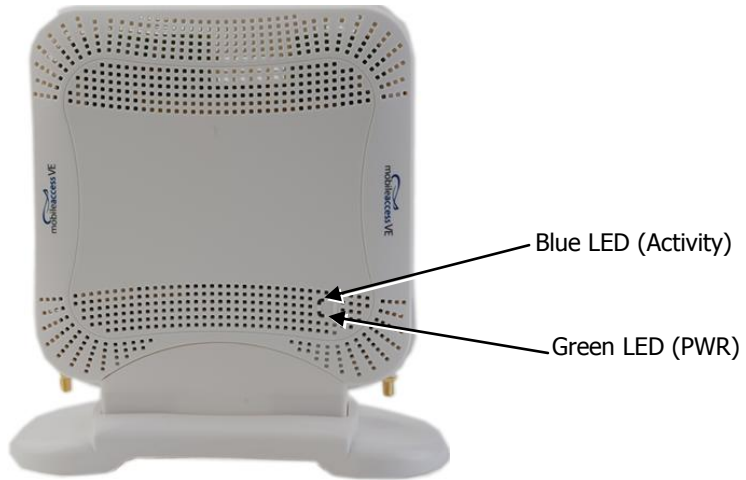

4. Locate the Access Pod.
5. It is advisable to assign it an identifiable name via the Access Pod **Module Info** tab, as described in section 5.6 (e.g. floor 3, room 2) and set the **Identify** field to **Off** again.

10.2 Wireless Service is Not Available

1. Verify that the Master VCU is connected to the BTS, powered up, and configured.
2. Verify that the Max Expected Power setting is correct by either:
 - A) Viewing the actual VCU Power Measurement (**Channel 1 / Channel 2 Pin**) in the VCU **RF Parameters** sub-tab (See below).

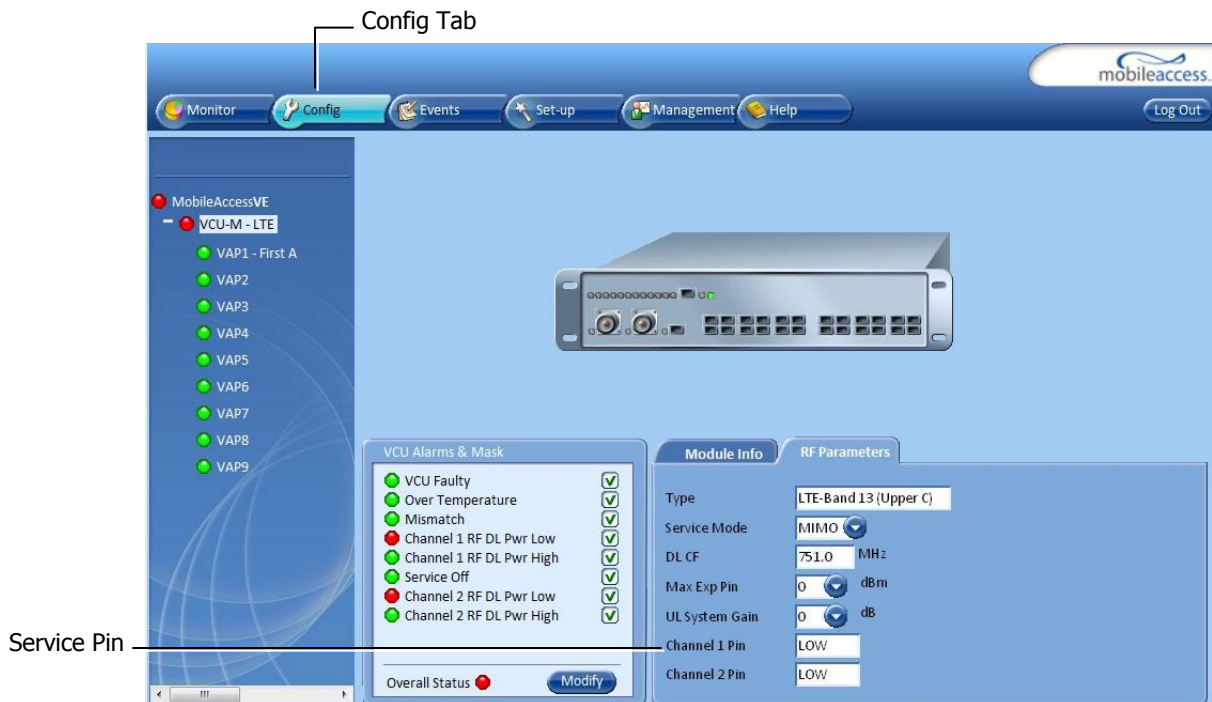

- B) or by measuring the actual BTS output using a Spectrum Analyzer.
3. Verify correct settings of center frequency and system gain (See **DL CF** and **UL System Gain** parameters in RF Parameters sub-tab – see example displayed above).
4. Verify that the RF cables are properly connected to the VCU.
5. View the VCU **Alarms** (above image) and verify that the VCU is working properly.

10.3 PoE is Not Working

Verify that the PoE used is "alternative a". The MobileAccessVE system currently only supports this alternative. Verify that all pairs are wired in the patch panels and jumper cords.

Note: Future enhancements will support "alternative b". Consult MobileAccess if you currently require support for "alternative b."

10.4 Ethernet Service is Degraded

Ethernet standards specify that 100m (300ft) is the maximum distance between an Ethernet switch and appliance (computer, WLAN AP, etc). This is relevant when MobileAccessVE shares the IT LAN. The distance includes all patch cords (from switch to VCU, from VCU to patch panel, from RJ-45 outlet to VAP, and from VAP to appliance).

1. Review the IT documentation, which may be available from your IT department, to determine cable types and lengths.
2. Check the lengths of the patch cords being used and verify the end-to-end distance does not exceed 100m (300ft).
3. A Fluke cable tester can be used to measure cable length.

10.5 No Service from Connected Access Pod

This requires physically accessing the Access Pod to check the LEDs, and accessing the Access Pod through the Web GUI to verify the Access Pod configuration.

1. Physically view the Access Pod and confirm that both LEDs on the Access Pod are lit:
 - Power LED (Green) is OFF – Either no connectivity to the VCU or the VAP is faulty. Try replacing the VAP. Try connecting the VAP directly to the VCU if the Power LED is lit check the cable and the patch cords.
 - Activity LED is constantly blinking – The Access Pod cannot initialize due to exceeded cable length. Try using the closest free RJ-45 jack fed with a different cable.



2. Check other Access Pods connected to the same VCU.
3. Verify that the VAP configuration as follows:
 - Connect to the VCU using the MobileAccessVE Web GUI application (See section 6.1).
 - In the VCU **Config** tab, click the **RF Parameters** sub-tab and verify that the **Service Mode** parameter is set (MIMO/SISO).

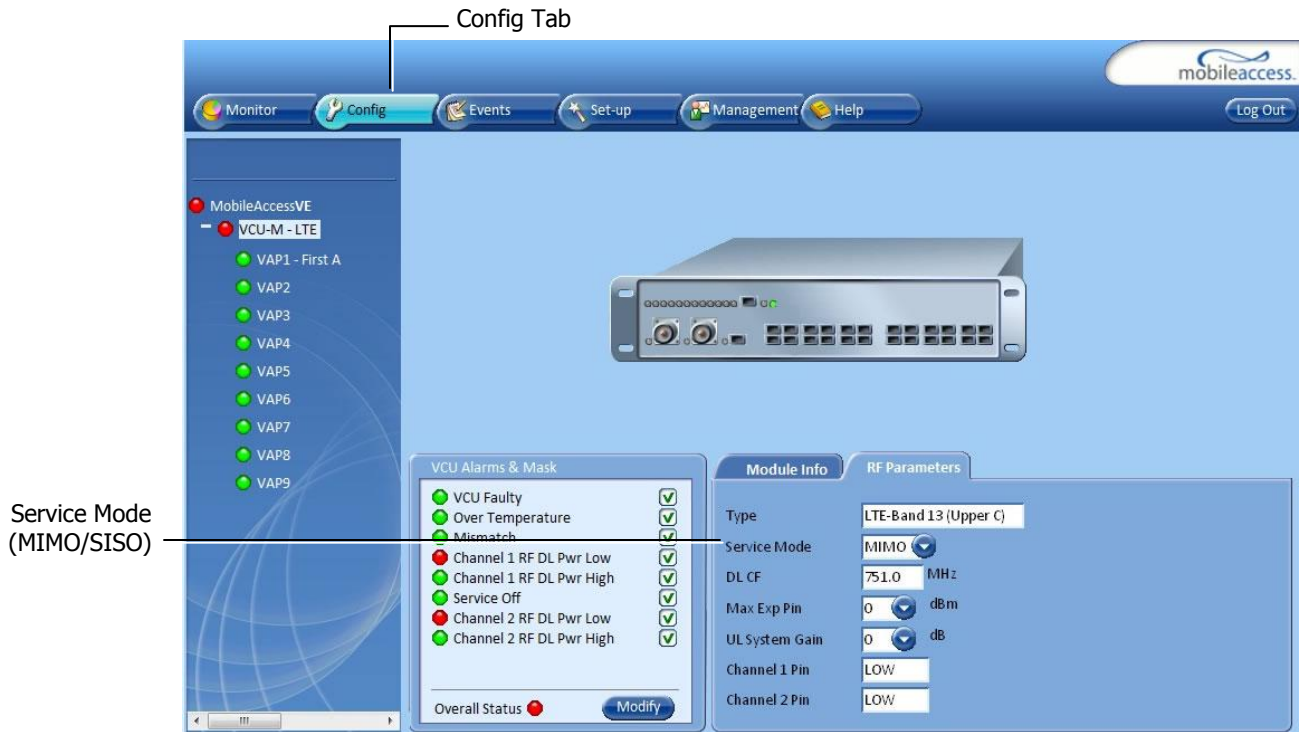

- Select the VAP from the topology tree and click the **RF Parameters** sub-tab.

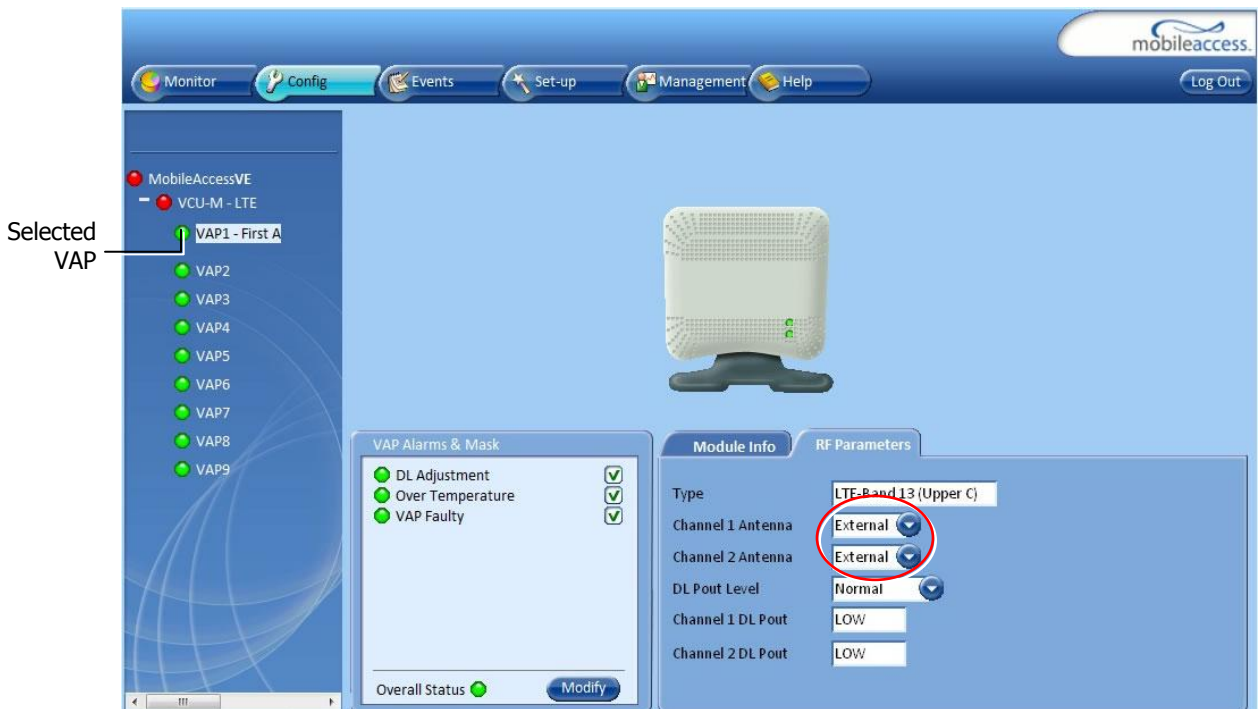

- Confirm that the VCU port is functioning (VAP Status LED - top LED in VAP icon associated with this Pod is green).

Note: The Activity LED on the actual VAP is BLUE.

- Verify the VAP was NOT configured by mistake to use the *internal* antennas (See **Channel 1 / Channel 2 Antenna** parameter in RF Parameters sub-tab, shown in previous figure).

10.6 VCU Cannot be Monitored via SNMP

VE traps are not received by the external Fault Monitoring system.

1. Verify that the VCU is powered ON.
2. Verify that the SNMP traps destination address is configured correctly.
3. Verify the IP connectivity to the Fault Monitoring server using “ping.”
4. Verify that SNMP port is not blocked or fire-walled in the IP network.
5. Initiate an Alarm and confirm the trap is received by external Fault Monitoring server. For example:
 - Access the VAP Service RF sub-tab. (See section 8.3).

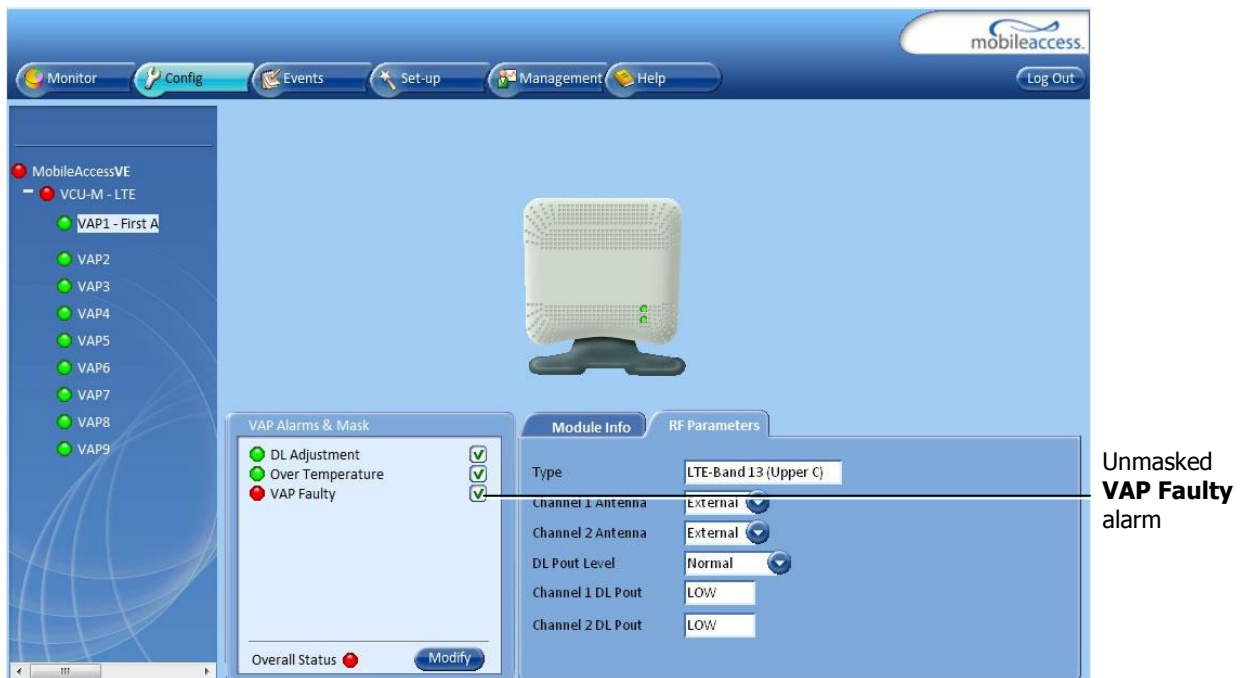

- Verify that the alarm is unmasked.
- Set the **Service Control** parameter to **Off**.
- Confirm the trap is received by external Fault Monitoring server.

Appendices

Traps

This section lists the MobileAccessVE LTE Controller and Access Pod Traps.

VE Control Unit (VCU) Traps

No	Trap Name	Trap Description
1	vcuChannel_1_DLPowerLow	Input RF power is Low (or no signal)
2	vcuChannel_1_DLPowerHigh	Input RF power is above the max expected Pin
3	vcuChannel_1_ServiceOff	Service is off
4	vcuChannel_2_DLPowerLow	Input RF power is Low (or no signal)
5	vcuChannel_2_DLPowerHigh	Input RF power is above the max expected Pin
6	vcuChannel_2_ServiceOff	Service is off
7	vcuFaulty	VCU HW is faulty
8	vcuOverTemperature	Temperature is above threshold
9	vcuAdjustment	Adjustment is failed
10	vcuMismatchType	VCU service is different than VAP services

VE Access Pod (VAP) Traps

No	Trap Name	Trap Description
1	vapAdjustment	When adjustment is failed
2	vapFaulty	When VAP HW is faulty
3	vapOverTemperature	When temperature is above threshold