



# **MobileAccess 2000 System**

## **Installation and Configuration Guide**

**P/N: 709C001208**

**REV: A0**

**Date: 08-FEB-09**

MobileAccess 8391 Old Courthouse Road, Suite 300, Vienna, VA 22182  
Tel: +1(866)436-9266, +1(703)848-0200 TAC: +1(800)787-1266, Fax: +1(703)848-0280  
<http://www.MobileAccess.com>

© COPYRIGHT 2009, MOBILEACCESS NETWORKS INC. ALL RIGHTS RESERVED.

MOBILEACCESS™ IS A REGISTERED TRADEMARK OF MOBILEACCESS. THIS DOCUMENT CONTAINS OTHER TRADEMARKS, TRADE NAMES AND SERVICE MARKS OF MOBILEACCESS AND OTHER ORGANIZATIONS, ALL OF WHICH ARE THE PROPERTY OF THEIR RESPECTIVE OWNERS.

THIS DOCUMENT CONTAINS CONFIDENTIAL AND PROPRIETARY INFORMATION OF MOBILEACCESS AND MAY NOT BE COPIED, TRANSMITTED, STORED IN A RETRIEVAL SYSTEM OR REPRODUCED IN ANY FORMAT OR MEDIA, IN WHOLE OR IN PART, WITHOUT THE PRIOR WRITTEN CONSENT OF MOBILEACCESS. INFORMATION CONTAINED IN THIS DOCUMENT SUPERSEDES ANY PREVIOUS MANUALS, GUIDES, SPECIFICATIONS, DATA SHEETS OR OTHER INFORMATION THAT MAY HAVE BEEN PROVIDED OR MADE AVAILABLE TO THE USER.

THIS DOCUMENT IS PROVIDED FOR INFORMATIONAL PURPOSES ONLY, AND MOBILEACCESS DOES NOT WARRANT OR GUARANTEE THE ACCURACY, ADEQUACY, QUALITY, VALIDITY, COMPLETENESS OR SUITABILITY FOR ANY PURPOSE OF THE INFORMATION CONTAINED IN THIS DOCUMENT. MOBILEACCESS RESERVES THE RIGHT TO MAKE UPDATES, IMPROVEMENTS AND ENHANCEMENTS TO THIS DOCUMENT AND THE PRODUCTS TO WHICH IT RELATES AT ANY TIME WITHOUT PRIOR NOTICE TO THE USER. MOBILEACCESS MAKES NO WARRANTIES, EXPRESS OR IMPLIED, INCLUDING, WITHOUT LIMITATION, THOSE OF MERCHANTABILITY AND FITNESS FOR A PARTICULAR PURPOSE, WITH RESPECT TO THIS DOCUMENT OR ANY INFORMATION CONTAINED HEREIN.

## Policy for Warrantee and Repair

MOBILEACCESS TESTS AND INSPECTS ALL ITS PRODUCTS TO VERIFY THEIR QUALITY AND RELIABILITY. MOBILEACCESS USES EVERY REASONABLE PRECAUTION TO ENSURE THAT EACH UNIT MEETS THEIR DECLARED SPECIFICATIONS BEFORE SHIPMENT. CUSTOMERS SHOULD ADVISE THEIR INCOMING INSPECTION, ASSEMBLY, AND TEST PERSONNEL ABOUT THE PRECAUTIONS REQUIRED IN HANDLING AND TESTING OUR PRODUCTS. MANY OF THESE PRECAUTIONS CAN BE FOUND IN THIS MANUAL.

THE PRODUCTS ARE COVERED BY THE FOLLOWING WARRANTIES:

### General Warranty

MOBILEACCESS WARRANTS TO THE ORIGINAL PURCHASER ALL STANDARD PRODUCTS SOLD BY MOBILEACCESS TO BE FREE OF DEFECTS IN MATERIAL AND WORKMANSHIP FOR ONE (1) YEAR FROM DATE OF SHIPMENT FROM MOBILEACCESS. DURING THE WARRANTY PERIOD, MOBILEACCESS WILL REPAIR OR REPLACE ANY PRODUCT THAT MOBILEACCESS PROVES TO BE DEFECTIVE. THIS WARRANTY DOES NOT APPLY TO ANY PRODUCT THAT HAS BEEN SUBJECT TO ALTERATION, ABUSE, IMPROPER INSTALLATION OR APPLICATION, ACCIDENT, ELECTRICAL OR ENVIRONMENTAL OVER-STRESS, NEGLIGENCE IN USE, STORAGE, TRANSPORTATION OR HANDLING.

### Specific Product Warranty Instructions

ALL MOBILEACCESS PRODUCTS ARE WARRANTED AGAINST DEFECTS IN WORKMANSHIP, MATERIALS AND CONSTRUCTION, AND TO NO FURTHER EXTENT. ANY CLAIM FOR REPAIR OR REPLACEMENT OF UNITS FOUND TO BE DEFECTIVE ON INCOMING INSPECTION BY A CUSTOMER MUST BE MADE WITHIN 30 DAYS OF RECEIPT OF SHIPMENT, OR WITHIN 30 DAYS OF DISCOVERY OF A DEFECT WITHIN THE WARRANTY PERIOD.

THIS WARRANTY IS THE ONLY WARRANTY MADE BY MOBILEACCESS AND IS IN LIEU OF ALL OTHER WARRANTIES, EXPRESSED OR IMPLIED. MOBILEACCESS SALES AGENTS OR REPRESENTATIVES ARE NOT AUTHORIZED TO MAKE COMMITMENTS ON WARRANTY RETURNS.

### Returns

IN THE EVENT THAT IT IS NECESSARY TO RETURN ANY PRODUCT AGAINST ABOVE WARRANTY, THE FOLLOWING PROCEDURE SHALL BE FOLLOWED:

1. RETURN AUTHORIZATION IS TO BE RECEIVED FROM MOBILEACCESS PRIOR TO RETURNING ANY UNIT. ADVISE MOBILEACCESS OF THE MODEL, SERIAL NUMBER, AND DISCREPANCY. THE UNIT MAY THEN BE FORWARDED TO MOBILEACCESS, TRANSPORTATION PREPAID. DEVICES RETURNED COLLECT OR WITHOUT AUTHORIZATION MAY NOT BE ACCEPTED.
2. PRIOR TO REPAIR, MOBILEACCESS WILL ADVISE THE CUSTOMER OF OUR TEST RESULTS AND ANY CHARGES FOR REPAIRING CUSTOMER-CAUSED PROBLEMS OR OUT-OF-WARRANTY CONDITIONS ETC.
3. REPAIRED PRODUCTS ARE WARRANTED FOR THE BALANCE OF THE ORIGINAL WARRANTY PERIOD, OR AT LEAST 90 DAYS FROM DATE OF SHIPMENT.

### Limitations of Liabilities

MOBILEACCESS'S LIABILITY ON ANY CLAIM, OF ANY KIND, INCLUDING NEGLIGENCE FOR ANY LOSS OR DAMAGE ARISING FROM, CONNECTED WITH, OR RESULTING FROM THE PURCHASE ORDER, CONTRACT, QUOTATION, OR FROM THE PERFORMANCE OR BREACH THEREOF, OR FROM THE DESIGN, MANUFACTURE, SALE, DELIVERY, INSTALLATION, INSPECTION, OPERATION OR USE OF ANY EQUIPMENT COVERED BY OR FURNISHED UNDER THIS CONTACT, SHALL IN NO CASE EXCEED THE PURCHASE PRICE OF THE DEVICE WHICH GIVES RISE TO THE CLAIM.

EXCEPT AS EXPRESSLY PROVIDED HEREIN, MOBILEACCESS MAKES NO WARRANTY, EXPRESSED OR IMPLIED, WITH RESPECT TO ANY GOODS, PARTS AND SERVICES PROVIDED IN CONNECTION WITH THIS AGREEMENT INCLUDING, BUT NOT LIMITED TO, THE IMPLIED WARRANTIES OF MERCHANTABILITY AND FITNESS FOR A PARTICULAR PURPOSE. MOBILEACCESS SHALL NOT BE LIABLE FOR ANY OTHER DAMAGE INCLUDING, BUT NOT LIMITED TO, INDIRECT, SPECIAL OR CONSEQUENTIAL DAMAGES ARISING OUT OF OR IN CONNECTION WITH FURNISHING OF GOODS, PARTS AND SERVICE HEREUNDER, OR THE PERFORMANCE, USE OF, OR INABILITY TO USE THE GOODS, PARTS AND SERVICE.

## Reporting Defects

THE UNITS WERE INSPECTED BEFORE SHIPMENT AND FOUND TO BE FREE OF MECHANICAL AND ELECTRICAL DEFECTS.

EXAMINE THE UNITS FOR ANY DAMAGE THAT MAY HAVE BEEN CAUSED IN TRANSIT. IF DAMAGE IS DISCOVERED, FILE A CLAIM WITH THE FREIGHT CARRIER IMMEDIATELY. NOTIFY MOBILEACCESS AS SOON AS POSSIBLE.

**NOTE:** KEEP ALL PACKING MATERIAL UNTIL YOU HAVE COMPLETED THE INSPECTION

**WARNING:** TO COMPLY WITH FCC RF EXPOSURE COMPLIANCE REQUIREMENTS, ANTENNAS USED FOR THIS PRODUCT MUST BE FIXED MOUNTED ON INDOOR PERMANENT STRUCTURES, PROVIDING A SEPARATION DISTANCE OF AT LEAST 20 CM FROM ALL PERSONS DURING NORMAL OPERATION.

**WARNING:** ANTENNA GAIN SHOULD NOT EXCEED 10 dBi.

**WARNING:** EACH INDIVIDUAL ANTENNA USED FOR THIS TRANSMITTER MUST BE INSTALLED TO PROVIDE A MINIMUM SEPARATION DISTANCE OF 20 CM OR MORE FROM ALL PERSONS AND MUST NOT BE CO-LOCATED WITH ANY OTHER ANTENNA FOR MEETING RF EXPOSURE REQUIREMENTS.

**WARNING:** THE DESIGN OF THE ANTENNA INSTALLATION NEEDS TO BE IMPLEMENTED IN SUCH A WAY SO AS TO ENSURE RF RADIATION SAFETY LEVELS AND NON-ENVIRONMENTAL POLLUTION DURING OPERATION.

## ATTENTION:

COMPLIANCE WITH RF SAFETY REQUIREMENTS:

MOBILEACCESS™ PRODUCTS HAVE NO INHERENT SIGNIFICANT RF RADIATION.

THE RF LEVEL ON THE DOWN LINK IS VERY LOW AT THE DOWNLINK PORTS. THEREFORE, THERE IS NO DANGEROUS RF RADIATION WHEN THE ANTENNA IS NOT CONNECTED.

## Laser Safety

FIBER OPTIC PORTS OF THE MOBILEACCESS 2000 EMIT INVISIBLE LASER RADIATION AT THE 1310/1550 NM WAVELENGTH WINDOW.

TO AVOID EYE INJURY NEVER LOOK DIRECTLY INTO THE OPTICAL PORTS, PATCHCORDS OR OPTICAL CABLES. DO NOT STARE INTO BEAM OR VIEW DIRECTLY WITH OPTICAL INSTRUMENTS. ALWAYS ASSUME THAT OPTICAL OUTPUTS ARE ON.

ONLY TECHNICIANS FAMILIAR WITH FIBER OPTIC SAFETY PRACTICES AND PROCEDURES SHOULD PERFORM OPTICAL FIBER CONNECTIONS AND DISCONNECTIONS OF THE MOBILEACCESS 2000 MODULES AND THE ASSOCIATED CABLES.

THE MOBILEACCESS 2000 COMPLIES WITH 21 CFR 1040.10 AND 1040.11 EXCEPT FOR DEVIATIONS PURSUANT TO LASER NOTICE NO. 50 (JULY 26, 2001) & IEC 60825-1, AMENDMENT 2 (JAN. 2001).

## Care of Fiber Optic Connectors

DO NOT REMOVE THE PROTECTIVE COVERS ON THE FIBER OPTIC CONNECTORS UNTIL A CONNECTION IS READY TO BE MADE. DO NOT LEAVE CONNECTORS UNCOVERED WHEN NOT CONNECTED.

THE TIP OF THE FIBER OPTIC CONNECTOR SHOULD NOT COME INTO CONTACT WITH ANY OBJECT OR DUST.

REFER TO THE CLEANING PROCEDURE FOR INFORMATION ON THE CLEANING OF THE FIBER TIP.

## Safety



**WARNING!** To comply with FCC RF exposure compliance requirements, antennas used for this product must be fixed mounted on indoor permanent structures, providing a separation distance of at least 20 cm from all persons during normal operation.

- 
1. Each individual antenna used for this transmitter must be installed to provide a minimum separation distance of 20 cm or more from all persons and must not be co-located with any other antenna for meeting RF exposure requirements.
  2. The design of the antenna installation needs to be implemented in such a way so as to ensure RF radiation safety levels and non-environmental pollution during operation.
- 

### Compliance with RF safety requirements:

- MobileAccess™ products have no inherent significant RF radiation.
- The RF level on the downlink is very low at the downlink ports. Therefore, there is no dangerous RF radiation when the antenna is not connected.

---

## Standards and Certification

MobileAccess products have met the approvals of the following certifying organizations:

### Product Certifications

**US** FCC 47 CFR part 15B, 22, 24, 90

**NOTE:** This equipment has been tested and found to comply with the limits for a Class B digital device, pursuant to Part 15 of the FCC Rules. These limits are designed to provide reasonable protection against harmful interference in a residential installation. This equipment generates, uses and can radiate radio frequency energy and, if not installed and used in accordance with the instructions, may cause harmful interference to radio communications. However, there is no guarantee that interference will not occur in a particular installation. If this equipment does cause harmful interference to radio or television reception, which can be determined by turning the equipment off and on, the user is encouraged to try to correct the interference by one or more of the following measures:

- Reorient or relocate the receiving antenna.
- Increase the separation between the equipment and receiver.
- Connect the equipment into an outlet on a circuit different from that to which the receiver is connected.
- Consult the dealer or an experienced radio/TV technician for help.

**Warning!**

Changes or modifications to this equipment not expressly approved by Mobile Access Ltd. could void the user's authority to operate the equipment.

UL 60950-1

21CFR 1040.10 & 1040.11.

**Europe** EN 301502, EN 300609, EN 301489, EN 60950-1, IEC 60825-1, IEC 60825-2

### Company Certification

ISO 9001: 2000 and ISO 13485: 2003

## About this Guide and Other Relevant Documentation

This user guide describes how to perform the physical installation of the MA2000 systems. The installation procedures of other units (RIU, MA850/860) relevant to the system are detailed in their user manuals (see *Additional Relevant Documentation* below).

### Revision History

The revision history for this document is shown in Table 1-1.

Table 1-1: Revision history

P/N	Date	Description
709C001305	September 2004	Initial version.
709C001307	JUNE 2007	New version that includes all previous updates.
	19-FEB-08	Update for 1000M products – Multi-mode fiber
709C001208	20-JAN-09	Updated DS in appendix for E-GSM products
	February 2009	International Configurations

### Additional Relevant Documents

The following documents are required if the corresponding units are included in your system installation.

Document Name
MA 850/860 Installation and Configuration Guide
RIU Installation and Configuration Guide
NMS MA 410/430 Installation and Configuration Guide
MA1000 MA2000 Commissioning Guide

## List of Acronyms

<b>BDA</b>	Bi-Directional Amplifier
<b>BTS</b>	Base Transceiver Station
<b>BTSC</b>	Base Transceiver Station Conditioner
<b>BU</b>	Base Unit
<b>DL</b>	Downlink
<b>RU</b>	Remote (Hub )Unit
<b>RIU</b>	Radio Interface Unit

**UL**

Uplink



# Table of Contents

<b>1</b>	<b>Introduction to the MA 2000 System</b>	<b>1</b>
1.1	System Architecture	2
1.2	Application Examples	4
<b>2</b>	<b>MA 2000 System Elements</b>	<b>6</b>
2.1	Enclosure Types	6
2.1.1	MA 2000 Remote Cabinet	6
2.1.2	MA 2000 Lite	9
2.1.2.1	Enclosure Internal Elements	10
2.1.2.2	Digital Card Unit	11
2.1.2.3	Filters and Combiners	12
2.2	MA 2000 Remote Location Units	12
2.2.1	RU 2000	12
2.2.2	MA 1200 Add-on	14
2.2.3	8 x 4 Combiner	16
2.2.3.1	MA 8x4 Combiner Front Panel	17
2.2.3.2	MA 8x4 Rear Panel	17
2.3	MA Base Unit	18
2.3.1	Base Unit Models and OPTMs	18
2.3.2	BU Panels	19
2.3.2.1	MA BU Front Panel	19
2.3.2.2	BU Rear Panel	20
<b>3</b>	<b>Site Preparation</b>	<b>21</b>
3.1	Infrastructure Preparation	21
3.2	Installation Requirements	21
3.3	Coaxial Cable Connections	22
3.3.1	General Cable Installation Procedures	22
3.3.2	Fiber Optic Rules	22
3.3.3	RF Rules	23
3.3.4	Coax Cable Lengths and Losses	24
3.4	Power Consumption, Connections and Power Supplies	25
3.4.1	Power Safety Instructions	25

3.4.2	Power Consumption of Units .....	25
3.4.3	Circuit Breakers .....	26
3.4.4	Types of Power Supplies.....	26
3.5	Installation Conventions .....	26
<b>4</b>	<b>System Installation .....</b>	<b>28</b>
4.1	Pre-installation Instructions.....	28
4.1.1	Unpacking and Inspection .....	28
4.2	Communication Room Installation .....	29
4.2.1	Rack Installation General Instructions.....	29
4.2.2	Rack Installation Safety Instructions.....	30
4.2.3	BU Connections .....	30
4.3	Remote Cabinet Installation .....	32
4.3.1	RC 2000 Wall Mount Installation .....	32
4.3.2	RC Grounding - Integrated PS Wall Mount Model.....	35
4.3.3	RC 2000 Rack Mount Installation.....	36
4.3.4	Fiber Optic Connections.....	38
4.3.5	Power Connections .....	39
4.3.5.1	Integrated Power Supply model .....	39
4.3.5.2	External Power Supplies Model.....	39
4.3.6	Antenna Connections .....	39
4.4	MA 2000 Lite Installation and Connections .....	40
4.4.1	Mounting MA 2000 Lite.....	42
4.4.2	MA 2000 Lite Connections .....	43
<b>5</b>	<b>Upgrading and Configuration Examples .....</b>	<b>44</b>
5.1	Common USA Configurations .....	45
5.1.1	iDEN/SMR with PCS Add-on .....	45
5.1.2	Cell/PCS.....	46
5.2	Typical International Configurations.....	47
5.2.1	Typical Asian Configuration: Cell/DCS+ UMTS .....	47
5.2.2	Typical European & Middle East Configuration: EGSM/DCS + UMTS Configuration .....	47
5.2.3	iDEN.....	48
5.3	2000 Lite Cell/DCS and GSM/DCS Config for Telstra .....	49
<b>6</b>	<b>Appendix : System Specifications .....</b>	<b>50</b>
	RF Parameters.....	50
	System Specs .....	54

Specifications of Units .....	55
MA 2000 MRC Remote Hub .....	55
MA 2000 Lite .....	55
MA 2000 Remote Unit .....	55
MA 1200 Add-On Specifications .....	55
Base unit Specifications .....	56
Ordering Information .....	56

# 1 Introduction to the MA 2000 System

**MobileAccess™-2000** series provides enterprise level indoor coverage, of a wide range of multi-operator wireless services over a single broadband infrastructure. Front-end wireless RF services are routed, over optic fibers, to MA 2000 series hubs that are securely located in remote telecommunication closets at each remote location. These modular service aggregation platforms precisely combine multiple wireless service signals for simultaneous distribution over a common broadband infrastructure.

Two remote service hub models are available:

- **MA-2000 Lite** – supports two remote units that are connected externally, where MA 1200 add-ons and MA 850/860 units can be integrated with the remote units.
- **MA-2000 Cabinet (MRC)** – internally houses a total of five remote units and MA 1200 add-on units with which MA 850/860 can be integrated as an external assembly.



Figure 1-1. MA 2000 Lite (left side) and MA 2000 Cabinet (right side)

The supported units are:

- **Remote Units (RUs)** – Service specific modules that support up to two voice services and perform the optic to RF conversion, filtering and amplification at the remote locations.
- **MA 1200 Add On** – Service specific module that provides support for an additional high band voice service.
- **MA 850/860** – Module that supports data services

### Features and Capabilities

- Multi-service platform that accommodates virtually any combination of wireless voice and data services eliminating the need for separate overlay networks
- Scalable and future-safe – services can be added and removed without affecting existing operators or end-users
- MA-2000 Lite components can be migrated to MA-2000 MRC for increased capacity
- All active components are located in the communication closet/room
- Carrier class operation – MA 2000 advanced signal handling ensures optimal performance for all services within a multi-operator deployment
- Local and remote end-to-end monitoring and control through interface to MA 410/430 controllers
- Conditioning and monitoring of input RF signals at the head-end through interface to MA-RIU

---

**NOTE:** MobileAccess is in the process of transition to 2000M products that will support both singlemode fiber and multimode fiber. The new Base Unit is designated by WBM (Wide Band M), and the new RHUs will be indicated by 2000M RHUs, *where the suffix "M" indicates that the product will support both single mode and multimode fiber usage.* The new products have the same packaging and performance and are fully backward compatible. See 3.3.2 for details on multimode fiber use.

---

## 1.1 System Architecture

At the head-end Mobile Access elements provide interface to the wireless service provider's network, where the signals can be conditioned through an active interface and transported over optic fiber to the remote end.

At the remote end, the optical signal is reconverted to RF, amplified, filtered and distributed over the broadband antenna infrastructure.

For end-to-end control, controllers installed at the head-end provide direct interface to the MA elements and through them, control over the remote end elements.

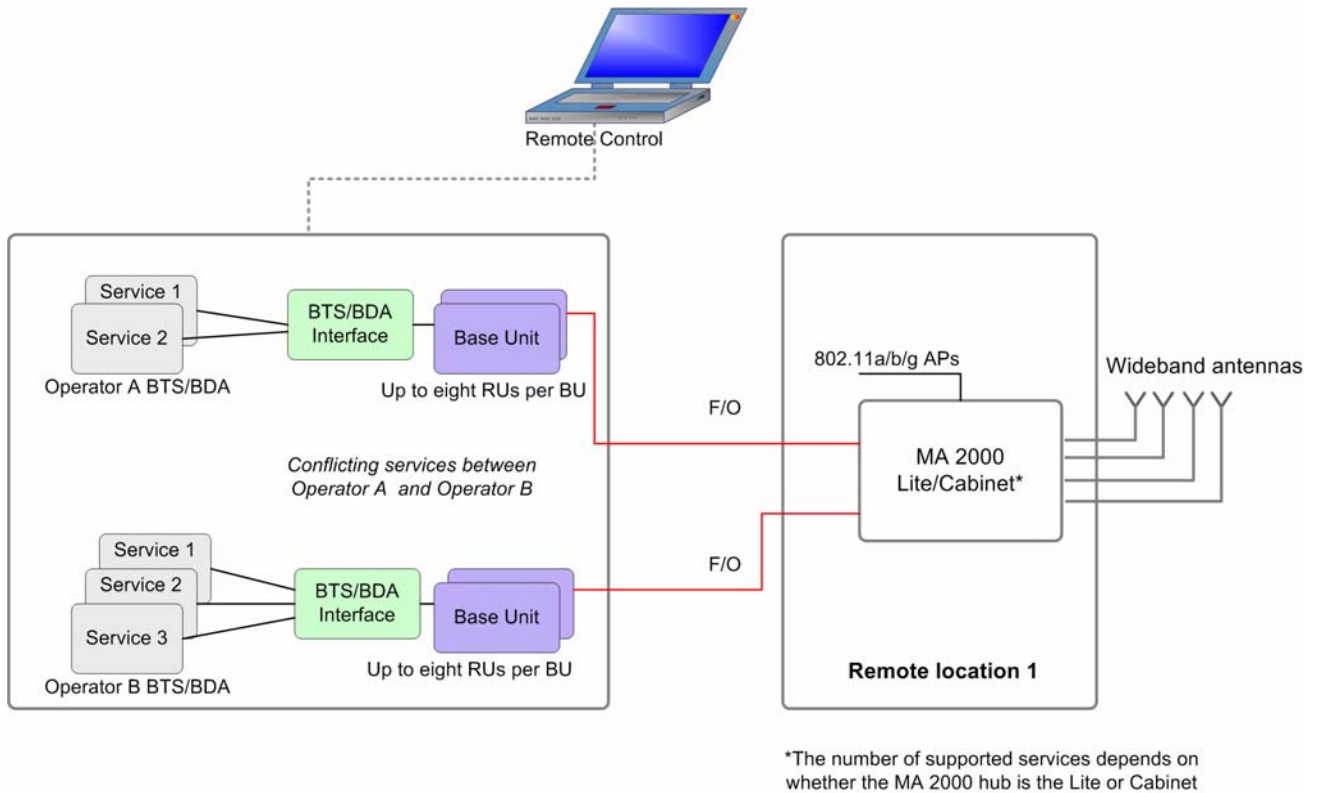

Figure 1-2. System Architecture

Figure 1-2 shows a basic block diagram of the system operation. On the downlink, services from the BTS/BDA are transferred via interface to the Base Units (BUs). The interface, which may be passive (i.e. Interface Box) or active (RIU), is used to attenuate the RF signals to the required levels, converge them and distribute them to the BUs. *The BUs are wideband – they are not service specific.*

At the BUs, the RF signals are converted to optical signals and transmitted over the optic fiber to (service-specific) RUs at the remote locations. At the remote locations, the RUs supported by the hub reconvert the optical signal to RF. The hub elements converge the voice services together with 802.11 a/b/g data services (if MA 850/860 units are installed) and distribute them over the coax antenna infrastructure. MA 410/430 (in installations with remote management) provides monitoring and control of all active system elements.

## 1.2 Application Examples

Figure 1-3 shows an example of an MA 2000 Cabinet based solution. Five services from two different operators are distributed, where services from Operator A conflict with those from Operator B.

The converted optical signal is routed from the BUs directly to the corresponding RUs in each Cabinet over optic fiber. Each BU supports connections to 8 RUs. Additional BUs are required for connection to more RUs.

Services 1 and 2 are distributed through one of the RUs supported in each Cabinet. Services 3, 4 and 5 are distributed through the second RU and the MA 1200 unit connected to that RU.

MA 850/860 converges 802.11a/b/g data services with the voice services to be distributed through a common infrastructure of coax and wideband antennas.

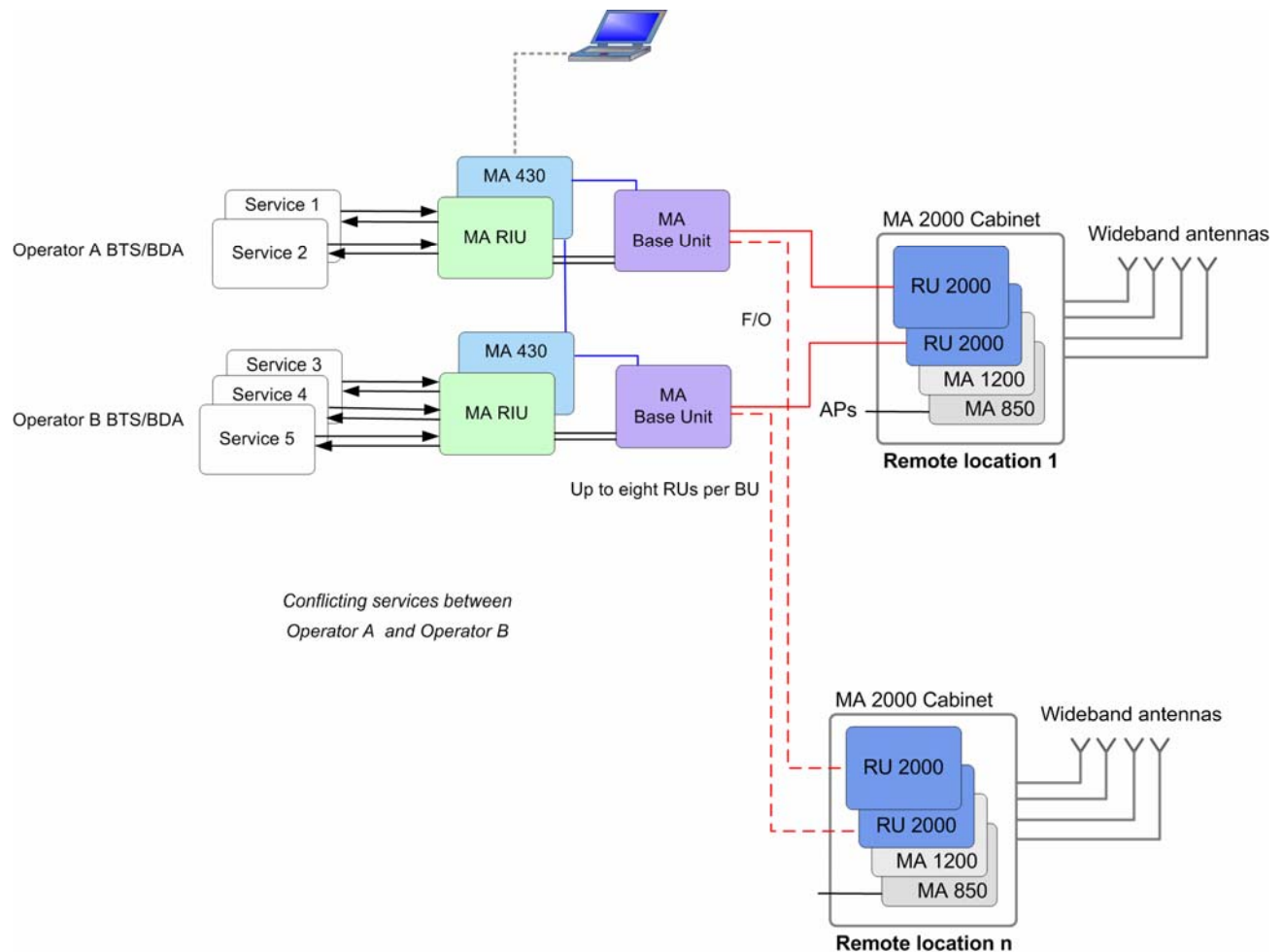

Figure 1-3. Example of MA 2000 Cabinet Architecture

Figure 1-4 shows an example of an MA 2000 Lite based solution. Four services from two different operators are distributed.

The converted optical signal is routed from the BUs directly to the corresponding RUs over optic fiber.

Services 1 and 2 are distributed through one of the RUs supported by MA 2000 Lite. Services 3 and 4 are distributed through the second RU. The combiner and filter provides interface to the antennas.

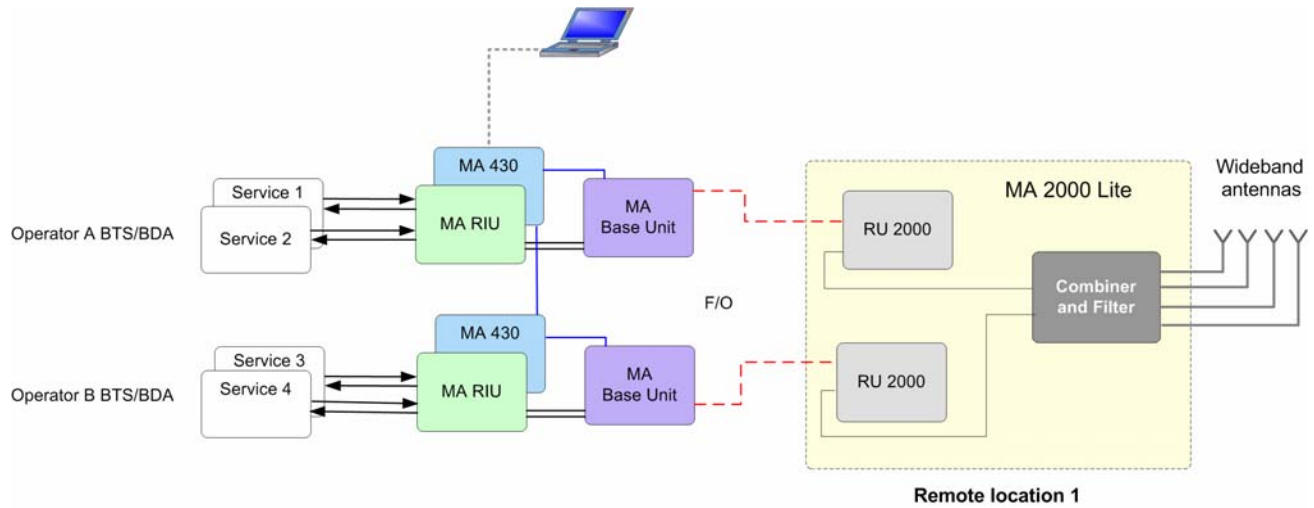

Figure 1-4. Example of MA 2000 Lite Architecture



# 2 MA 2000 System Elements

This chapter provides a full, detailed description of each of the system elements and their individual connections. The element descriptions are organized according to the following sections:

- Enclosures types – Cabinet and Lite
- Remote Location Elements:
  - MA 2000 Remote Units (RUs)
  - 1200 Add-on
- Base Unit

---

**NOTE:** The following elements are fully described in their corresponding user guides: **MA RIU, MA 850/860, MA 410/430 Controllers and MCT/NMS Management Application** (described in MA 410/430 Installation and Configuration Guide).

---

## 2.1 Enclosure Types

This section describes both types of enclosures (Cabinet/Lite) and their external connections.

### 2.1.1 MA 2000 Remote Cabinet



*Figure 2-1. RC 2000 Closed Cabinet View*

MA 2000 Cabinet supports the following functions:

- Compactly houses up to five RU 2000 and MA 1200 modules and the required filters

---

**NOTE:** The number of modules that can be housed depends on the models, required filtering, etc.

---

- MA 850/860 can be connected externally

- Converges all voice services and provides a single interface to the antennas through external connections
- Wall mounted or rack mounted
- Supplied in two models with differing power supply:
  - Integrated power supply – fed from an external AC power source. The RU 2000 and MA 1200 Add-on modules are internally connected to the power supply. This model includes a battery connection as well.
  - External power supplies – power is routed to external connectors from which power is routed internally to each RU 2000 and MA 1200 Add-on module.

### Open door views

The following figure shows an open RC 2000 cabinet, integrated power supply model, with four RU 2000 modules and four filters. (For clarity, the internal connections are demonstrated separately in Figure 2-3).

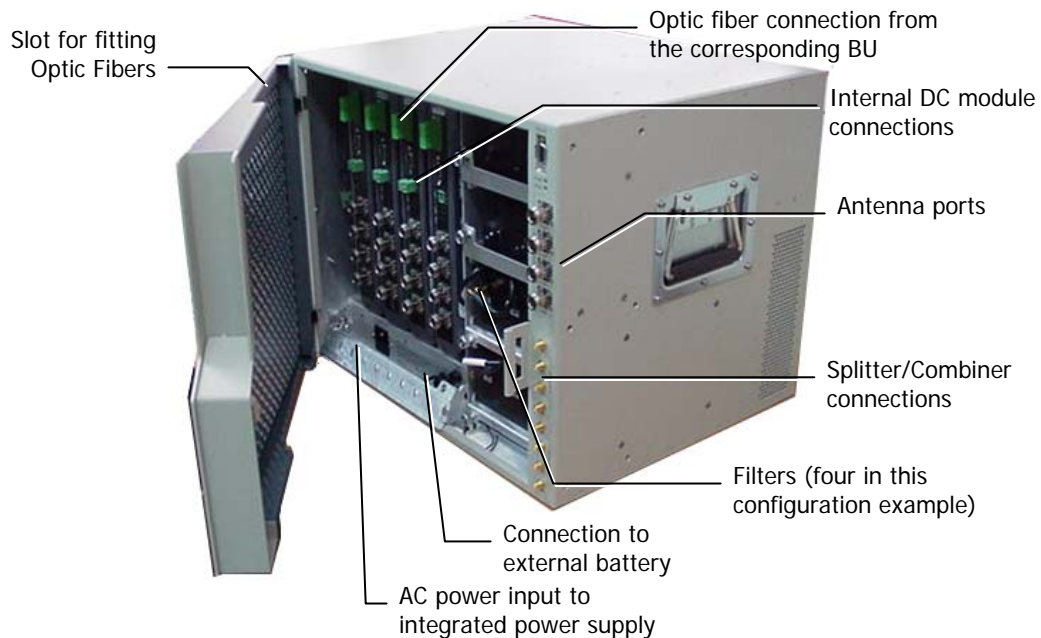
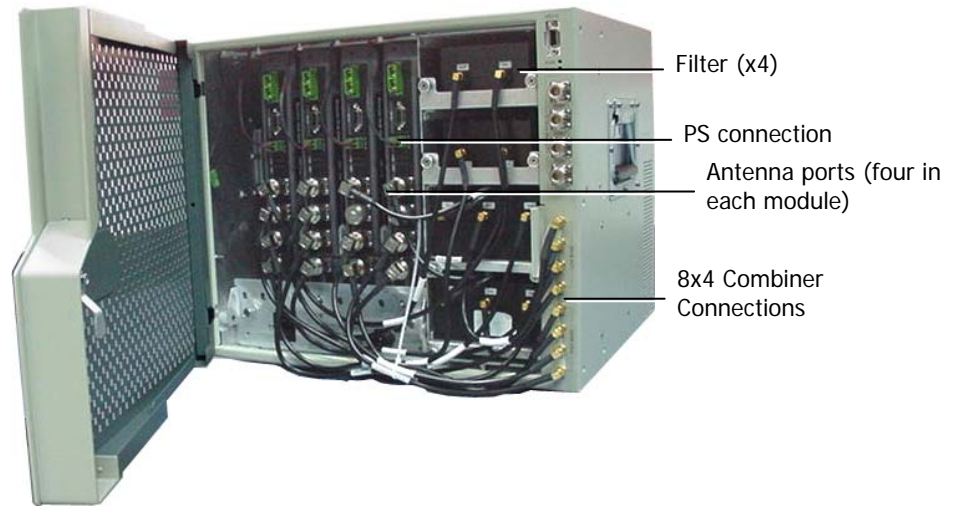

Figure 2-2. RC 2000 Open Cabinet View (without internal connections)

The following image shows the MA 2000 RC with the cabling. The antenna ports of the individual modules are connected to the relevant filters and to the 8x4 Combiner. The PS connections of each module are also connected to cables that are internally routed to the integrated PS (a full detailed description of the connections is provided in chapter 5 ).

**NOTE:** The fiber optic connections are not displayed.



*Figure 2-3. RC Open Cabinet with Internal Cabling*

### 2.1.2 MA 2000 Lite

The 2000 Lite is designed to support up to 8 voice services, in addition to 802.11 data services.

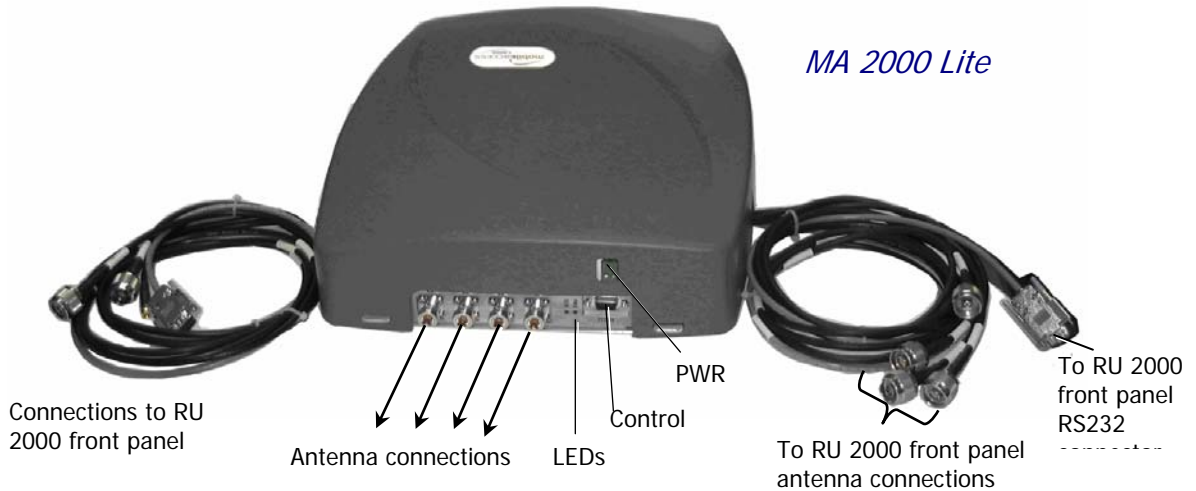

Figure 2-4. 2000 Lite System

#### MA 2000 Lite capabilities:

- External connections to two MA 2000 RUs (to which MA 1200 Add-on units can be added)
- Internal filters and combiner (converges all services)
- Connection to MA 850/860 for support of 802.11a/b/g data services
- External power supplies

The MA 2000 enclosure contains two sets of cables, each providing connections to two MA 2000 RUs.

Cable Connector	Description
Four N-type connectors	Coax connections to corresponding antennas
1x DB-9 connector	Connection to RU front panel RS232 connector

The following table describes the MA 2000 Lite front panel connectors.

Connector	Description
Ant-1 to Ant-4 (N-type)	Coax connections to corresponding antennas
Control	Control connector for MA service personnel.
Power	20 to 48V DC power input

The following table describes the front panel LEDs.

LEDs	Description
Run	Module is operating properly.
Power	Green – required power is supplied.

### 2.1.2.1 Enclosure Internal Elements

The MA 2000 Lite enclosure includes:

- 8x4 Combiner (see section 2.2.3 for description)
- Digital Card unit (see 2.1.2.2).
- Filters and Combiners (see 2.1.2.3).

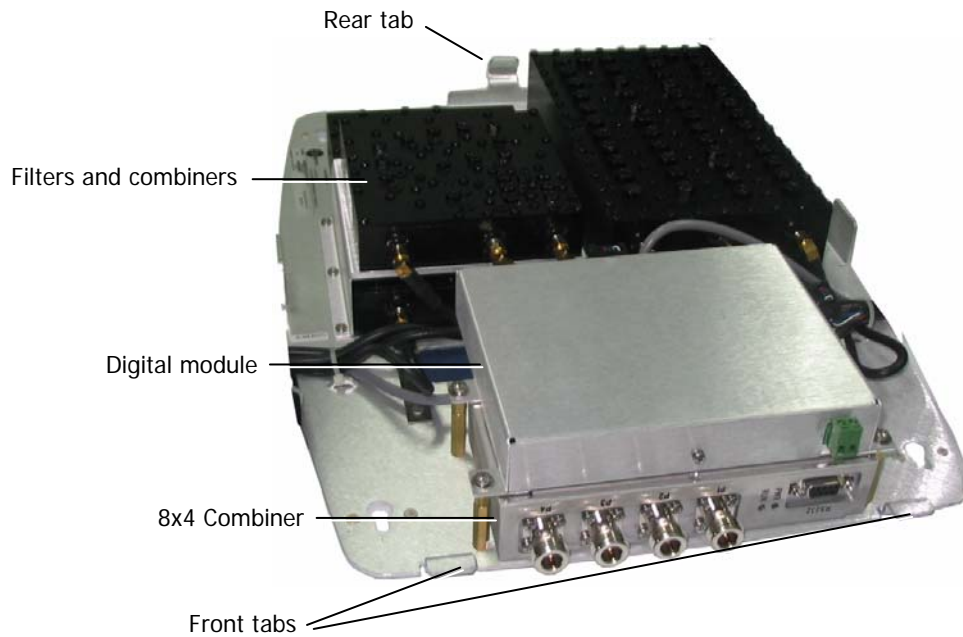

Figure 2-5. MA 2000 Lite Internal Units

2.1.2.2 Digital Card Unit

**NOTE:** This unit is internal to the MA 2000 Lite system.

The Digital unit enables antenna monitoring. It is connected to the 8x4 Combiner and to each of Remote Units.

**Digital Unit Front Panel**

The front panel of the unit contains the power connector.



Figure 2-6. Digital Front Panel

The following table describes the front panel connectors.

Connector	Description
PWR	20 to 48VDC. The PWR connector is external on the M2000 Lite enclosure front panel.

**Digital Unit Rear Panel**

The rear panel of the unit contains the control connections to the 8x4 Unit and to the Remote Units.

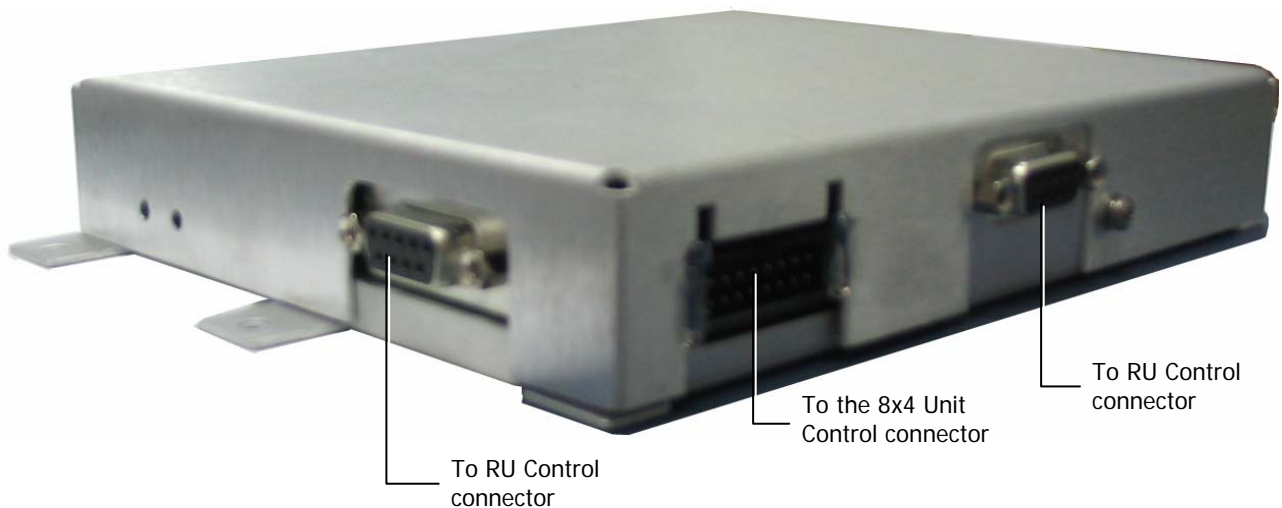

Figure 2-7. Digital Rear Panel

### 2.1.2.3 Filters and Combiners

The filters and combiners vary according to the type of Remote Units. The filter and combiner connections are described in Chapter 5 Upgrading and Configuration Examples.

## 2.2 MA 2000 Remote Location Units

Service specific units located at each remote location convert the optical signals received from the Base Units to RF signals and route them to the coax antenna infrastructure.

---

**NOTE:** The voice services are converged by an **8x4 Combiner** unit that is installed in the Cabinet enclosure and the Lite module.

---

The following types of service specific elements are available:

- **Remote Units (RUs)** – support two voice services
- **MA 1200 Add-on** – adds an additional (third) voice service to the host RU to which it is connected.
- **MA 850/860** – converges data services from 802.11a/b/g APs and distributes them over the same coax and antenna infrastructure

---

**NOTE:** The MA 850/860 is described in detail in the MA 850/860 Configuration and Installation guide.

---

### 2.2.1 RU 2000

RU 2000 is a service specific module that is either housed in the MA 2000 Cabinet or connected externally to the MA 2000 Lite module.

It provides the following functions:

- Performs the optic to RF (and vice versa) conversion at the remote locations
- Supports two services – high-band and low-band
- Interfaces to the optic fiber from the BU
- Add-on ready – MA 1200 can be added to support an additional services
- Remote management - requires connection of host BU connection to a MA 410/430 controller

### RU 2000 Front Panel

The RU 2000 front panel contains the fiber optic connections to the BU, four coax connections to the antennas, power connections and status indicators.

The RU 2000 front panel contains the fiber optic connections to the BU, four coax connections to the antennas, power connections and status indicators.



Figure 2-8. RU 2000 Front Panel

Figure 2-9. RU 2000 Front Panel

**Table 2-1. RU 2000 Front Panel Indicators**

LED	Description
COMM	Active communication detected
LINK	Optical link to BU detected
PWR	DC power connection. 20 to 48VDC



## RU 2000 Rear Panel

The RU 2000 rear-panel provides the control, RF interface and optic interface ports that enable connecting an MA 1200 add-on unit to the RU 2000 module.



Figure 2-10. RU 2000 Rear

Table 2-2. RU 2000 Rear Panel Connectors

<b>Add-on control</b>	Transmits the control signals from MA 1200 add-on module to the RU 2000 module. The <b>Add-on Control</b> port is connected to the MA 1200 add-on <b>From</b> port.
<b>DL, UL</b>	Transmit the RF signals to- and from- the MA 1200 add-on module. These ports are connected to the corresponding ports on the MA 1200 rear panel: DL to DL, UL to UL.

### 2.2.2 MA 1200 Add-on

The MobileAccess 1200 Add-on module is used to provide support for an additional service to an MA 2000 RU. The host MA RU and the MA 1200 add-on are interconnected and either housed in a MA 2000 Cabinet or connected externally to a MA 2000 Lite 'enclosure'.

MA 1200 Add-on provides the following functions:

- Single service – either low-band or high-band
- Installed only as an addition to a MA 2000 RU

---

**NOTE:** MA 1200 add-on does NOT interface directly to the fiber optic infrastructure, does not perform the optic to RF conversion and does not interface to the antennas. All these functions are provided by the host RU 2000 unit.

---

**MA 1200 Front Panel**

The RU 1200 front panel contains the power connection and status LEDs. (The RS-232 connector is reserved for MA service personnel). The figure below shows the MA 1200 front view. It is followed by a description of the connections and LEDs.

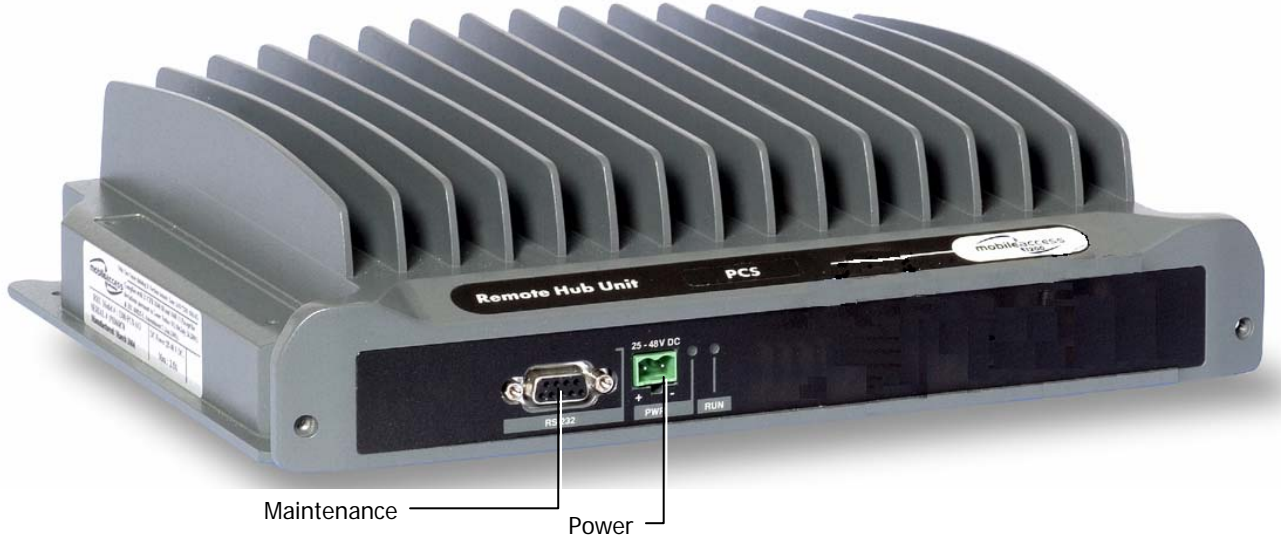

Figure 2-11. RU 1200 Front panels

**Table 2-3. MobileAccess 1200 Front Panel Connectors**

LED	Description
RS232	Servicing connector to be used by MA service personnel for maintenance.
PWR	DC Power connection. 25 to 48VDC

**Table 2-4. MobileAccess 1200 Front Panel Indicators**

LED	Description
RUN	When blinking, indicates that the RU is in normal operating mode.
PWR	Power ON

### MA 1200 Rear Panel

The RU 1200 rear panel contains the control connectors and the RF connections to the RU 2000 and MA 850/860.

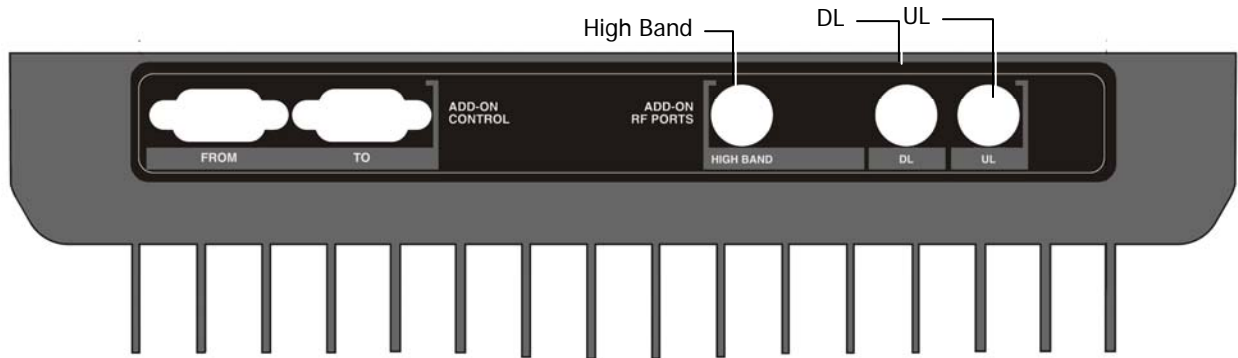

Figure 2-12. RU 1200 Rear Panel

Table 2-5. RU 1200 Rear Panel Connectors

<p><b>Add-on Control</b></p>	<p>Transmits the control signals between the MA 1200 module and the MA 850/860 and RU 2000 modules.</p> <p><b>From</b> – receives control signals from the RU 2000. Connected to the RU 2000 <b>Add-on Control</b> connector.</p> <p><b>To</b> – feeds control signals to MA 850/860 (in configurations that include MA 850/860)</p>
<p><b>DL, UL</b></p>	<p>Transmit the RF signals to- and from- the MA 1200 add-on module. These ports are connected to the corresponding ports on the MA 2000 rear panel: DL to DL, UL to UL.</p>
<p><b>High</b></p>	<p>Service RF output port. Connected to combiner/splitter to be combined with other services supported by the MA 2000 system.</p>

### 2.2.3 8 x 4 Combiner

**NOTE:** This unit is internal to the MA 2000 system – both Cabinet and Lite models.

This unit is installed in the MA 2000 system Cabinet and MA 2000 Lite enclosures. It combines the RF outputs of the RUs in the corresponding system and provides a common interface to the coax antenna infrastructure.

**The 8x4 Combiner provides the following capabilities:**

- Supports up to eight RF voice service connections: four high-band and four low-band
- Supports four antenna interface ports (located externally on the MA 2000 Lite)
- Provides low RF loss and high isolation for the input devices

### 2.2.3.1 MA 8x4 Combiner Front Panel

The front panel of the unit contains the four antenna interface ports, LEDs and control port.

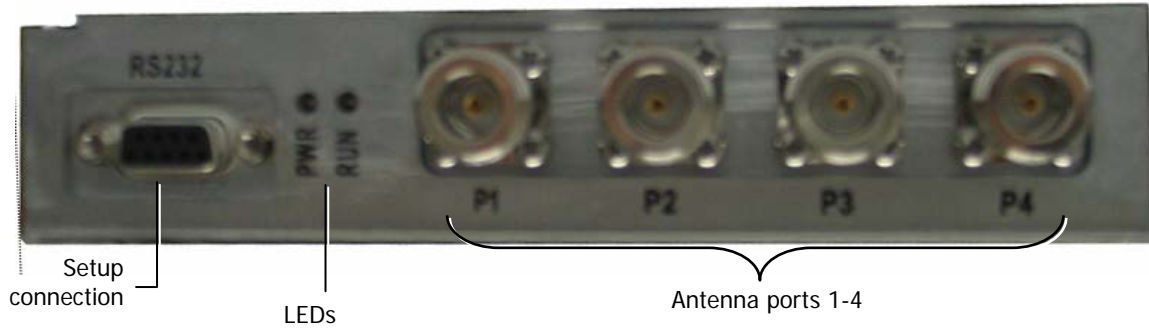

Figure 2-13. 8x4 Combiner Front Panel

The following table describes the front panel connectors.

Connector	Description
Ant-1 to Ant-4 (N-type)	Connections to corresponding antennas
Setup	Future Option

### 2.2.3.2 MA 8x4 Rear Panel

The rear panel of the unit contains four low-band and four high-band ports as well as the control port.

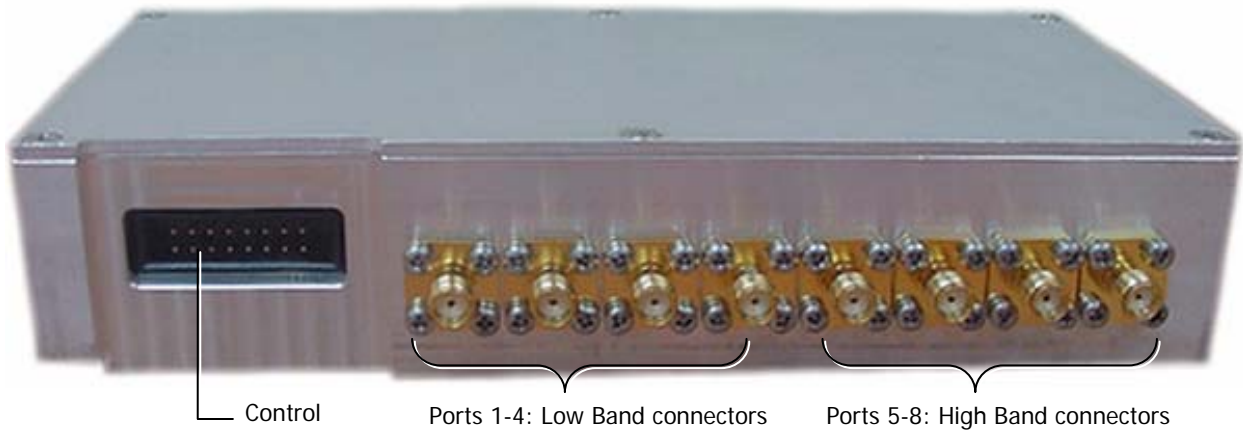

Figure 2-14. 8x4 Combiner Rear Panel

*Continued on the following page*

The following table describes the rear panel connectors.

---

**NOTE:** Connector on rear panel is for future option.

---

SMA Connectors	Description
Low Band	Four connectors (ports 1-4) for the <b>low-band</b> outputs of the corresponding remote unit. Refer to <i>Chapter 5</i> for the exact connections relevant to each configuration.
High Band	Four connectors (ports 5-8) for the <b>high-band</b> outputs of the corresponding remote unit. Refer to <i>Chapter 5</i> for the exact connections relevant to each configuration.
Control	Interfaces to the Digital card (that enables antenna monitoring)

## 2.3 MA Base Unit

The BU (Base Unit) is a wideband device that performs the conversion between the BTS/BDA (passive or active) interface RF signal and the remote units optic signal.

### Base Unit capabilities

- Supports all services distributed by MobileAccess systems
- Fiber connection to up to 8 RUs
- Setup and monitoring through connection to the host MA 410/430 controller and MCT software application
- Dry contact alarms
- Front panel indicators providing status on optical link internal circuitry and signal level

### 2.3.1 Base Unit Models and OPTMs

Two models of MA BUs are available:

- Four-port unit – supports optic connections to four RUs
- Eight-port unit – supports optic connections to eight RUs

Each 4-port unit is referred to as OPTM. An 8-port unit consists of two 4-port modules or, referred to as OPTMs.

---

**NOTE:** Each 4-port module (**OPTM**) is separately accessed and managed in the MCT and NMS management applications.

---

## 2.3.2 BU Panels

### 2.3.2.1 MA BU Front Panel

The front panel contains the optical connections and indicators. Each four-port element has a dedicated set of indicators (PWR, LSR and Link 1 to Link 4 or Link 5 to Link 8).

Four ports and corresponding indicators

Four ports and corresponding indicators



Figure 2-15. Eight-Port MA BU Front Panel



Figure 2-16. Four-Port BU Front Panel

**Table 2-6. MA BU Front Panel Indicators**

LED	Description
PWR	Power input detected for the corresponding unit. 20 to 48VDC
LSR	ON - laser circuitry for the corresponding element (group of four ports) is functioning correctly.
Link 1-4, 5-8	ON - the optical link to/from the connected remote functions within the specifications in both directions. Blinking - optical power from remote is lower than required

2.3.2.2 BU Rear Panel

The BU rear panel contains the RF connections, Alarms, NMS and power connections.

**NOTE:** The following figure shows the rear panel of an 8-port BU. A 4-port BU contains a single UL and a single DL RF connector.

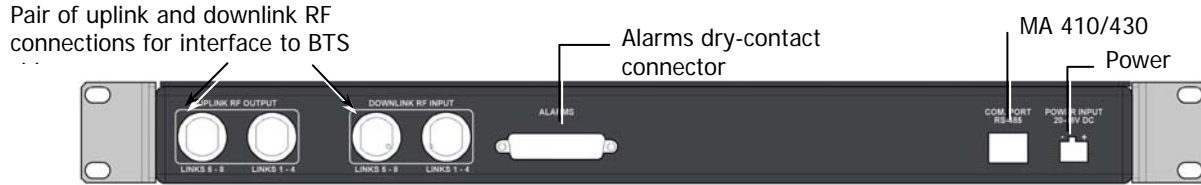

Figure 2-17. MA BU Rear Panel (RF Connections)

**Table 2-7. MobileAccess 1000 Rear Panel Connections**

Connector	Description
Uplink output	Uplink connectors to be connected on BTS/BDA side. For an 8-port BU, both UL connectors must be connected.
Downlink input	Downlink connectors to be connected on the BTS/BDA side. For an 8-port BU, both DL connectors must be connected.
Com Port RS485	Connection to MobileAccess 410/430 controller, rear panel RS485 port.
Alarms	Dry-contact connections to BTS/BDA (normally closed). Relevant only for system without MA 410/430 controllers.
PWR	Power connection: 20 to 48VDC

# 3 Site Preparation

## 3.1 Infrastructure Preparation

The following installation rules are based on the assumption that site survey and installation planning (*including power requirements*) have been completed.

## 3.2 Installation Requirements

The infrastructure preparation consists of two main phases:

- A. **Floor Planning:** Planning the distribution of the antennas on each floor to provide the required coverage.
- B. **Telecom Closet Planning:** Planning the layout of the devices and cables in the telecom closet or shaft. This includes the MA 850/860, 802.11 Access Points, cabling and other voice service distribution systems that are relevant to the specific installation.



## 3.3 Coaxial Cable Connections

### 3.3.1 General Cable Installation Procedures

Observe the general cable installation procedures that meet with the building codes in your area. The building code requires that all cabling be installed above ceiling level (where applicable). The length of cable from the risers to each antenna must be concealed above the ceiling.

The cable must be properly supported and maintained straight using tie-wraps, cable trays and clamps or hangers every 10 feet (where practical above ceiling level). Where this is not practical, the following should be observed:

- The minimum bending radius of the supplied ½" coax cable should be 7".
- Cable that is kinked or has a bending radius smaller than 7" must be replaced.
- Cable runs that span less than two floors should be secured to suitably located mechanical structures.
- The cables should be supported only from the building structure.

### 3.3.2 Fiber Optic Rules

- Either single mode or multimode fiber can be used with MobileAccess 1000M products, while MobileAccess 1000 products can only be used with single mode fiber.
- Only Multimode fiber, 50/125 or 62.5/125um complying with ANSI/TIA/EIA-568-B series, EN50173-1 or ISO/IEC 11801 can be used. The fiber length can be up to 300 meters assuming the following qualifications:
  - All fiber in a given length of fiber must be of the same core diameter.
  - All Bulkhead adapters must be Single mode SC/APC (Green) adapters.
  - All terminations cross connections or patches must be direct fusion splice or MobileAccess specified patch cords listed below.

900 microns patchcord for splicing, 2 Meters, 2xSC/APC		
Diamond p/n ENC/1045341	Beige boots, 62.5/125/900	MA# 500001057
Diamond p/n ENC/1045340	Black boots, 50/125/900	MA# 500001058

Zipcord patchcord, 4xSC/APC, 50/125/900/2000/4500 micron		
Diamond p/n ENC/1045342	Black/Brown boots, 1Meter	MA# 50000105
Diamond p/n ENC/1045343	Black/Brown boots, 3 Meter	MA# 500001060

Zipcord patchcord, 4xSC/APC, 62.5/125/900/2000/4500 micron		
Diamond p/n ENC/1045344	Beige/Brown boots, 1 Meter	MA# 500001061
Diamond p/n ENC/1045345	Beige/Brown boots, 3 Meter	MA# 500001062

- **Use only 8-degree SC/APC connectors (green color).**
- Use **only** fusion splice for connecting two fibers.
- Use minimum splicing/connectors to achieve minimum losses on the fibers (<0.5dB).
- Use precaution while installing, bending, or connecting fiber optic cables.
- Use an optical power meter and OTDR for checking the fiber optic cables.
- Make sure the environment is **clean** while connecting/splicing fiber optic cables.
- All fiber optic connections should be cleaned prior to attaching to termination points using a dry cleaning device (i.e. Cletop or equivalent).
- Fiber connector protective caps should be installed on all non-terminated fibers and removed just before they are terminated.
- Verify the Fiber Optic connections. You may use the Optical Test Procedure described at the end of this manual.
- Pay special attention while connecting the SC/APC connectors - you must hear the "click" when the connection is made.

### 3.3.3 RF Rules

- Use coax RG223, 50ohm, male-to-male N-type for RF connections from the BUs to the BTS/RBS and to the RIU.
- When using the MobileAccess™ system in an environment in which other indoor coverage systems are installed, it is recommended (where possible) that the antennas are placed at least two meters apart
- When bending coax cables, verify that the bending radius does not exceed the coax specifications.
- Use wideband antennas supporting a range of 800Mhz to 2500Mhz
- Use a VSWR meter (i.e. Site Master or equivalent) for checking coax cables, including the antennas. (<2). The VSWR must be measured prior to terminating the RUs in the remote communication rooms
- Terminate all unused **RU** and **RIU** ports with a 50 ohm load

### 3.3.4 Coax Cable Lengths and Losses

Use coax ½", 50ohm, male-to-male N-type, for connecting to RHU and antenna ports.

**NOTE:** The required distance between the antennas (installed in the ceiling) depends on the infrastructure and calculated path-loss. For example, if there is free space-loss between the antennas, a minimum distance of 100 ft is required; if there are partitions (loss) between the antennas, a distance of less than 100 ft between them is allowed.

Coax Length	coax Loss (900Mhz)	connector loss	Total Loss
30	0.7	1.5	2.2
40	0.9	1.5	2.4
50	1.1	1.5	2.6
60	1.3	1.5	2.8
70	1.5	1.5	3
80	1.7	1.5	3.2
90	1.9	1.5	3.4
100	2.1	1.5	3.6
110	2.3	1.5	3.8
120	2.5	1.5	4
130	2.7	1.5	4.2
140	2.9	1.5	4.4
150	3.1	1.5	4.6
160	3.3	1.5	4.8
170	3.5	1.5	5
180	3.7	1.5	5.2
190	3.9	1.5	5.4
200	4.1	1.5	5.6

## 3.4 Power Consumption, Connections and Power Supplies

### 3.4.1 Power Safety Instructions



#### SAFETY WARNINGS

- When installing or selecting the power supplies:
- Be sure to disconnect all power sources before servicing.
- MA 410/430 Controller lithium type battery should only be replaced by MobileAccess service personnel. **Risk of exploding if battery is replaced by an incorrect type.** Dispose of used batteries according to the instructions.
- Calculate the required power according to the requirements of the specific installation and then determine the configuration of the power supplies. The required DC cables will then be determined by the selected PS configuration.
- Use only **UL** approved power supplies
- **AC and DC power supply cables** – use only the power cords supplied with the units
- **Battery replacement in units** - only the MA 410/430 controller has batteries. These should be replaced (when necessary) only by MA Service Personnel.
- Install external over-current protective devices for the system according to the requirements described in section 3.4.2.

### 3.4.2 Power Consumption of Units

**Table 3-1. MobileAccess™ Power Requirements**

Unit Type	Voltage Input	Typical Power Consumption	Maximum Current Consumption
2000 Remote Cabinet	20 to 48VDC	25W	1.25A
2000 Lite	20 to 48VDC	3W	0.15A
RU 2000	20 to 48VDC	25W	1.25A
Add-on Unit 1200	25 to 48VDC	50W	2.0A
RIU	20 to 48VDC	12W	0.6A
Base Unit	20 to 48VDC	14W	0.7A
410/430 Controller	20 to 48VDC	10W	0.5A
MA 850/860	20 to 48VDC	20W	1.0A

### 3.4.3 Circuit Breakers

Install fuse protections for the system according to the following criteria:

- The following system elements require external fuse protection: **RIUs, BUs, and 410/430 Controllers.**
- Referring to Table 3-1, calculate the required fuse protection.
- **Example:** a set of three elements consisting of a BU, RIU and MA 410/430 controller requires a 2A circuit breaker.

### 3.4.4 Types of Power Supplies

MobileAccess supplies various power supplies that can be installed in a rack or mounted on a wall, depending on your configuration.

---

**NOTE:** Refer to Appendix II, section 0 for list of power supplies.

---

## 3.5 Installation Conventions

Some of the basic installation conventions are listed below for the MA 2000 system:

- **Base Units** – are usually concentrated in the same location, most often in the main communication room.
- **Remote Cabinet/Lite** – usually placed in the communication shaft or closet of a corresponding floor so they can be easily located. Each cabinet (or 2000 Lite) can typically cover a floor of up to 30,000 sq ft.
- **Fiber optic cable** - bundled fibers are terminated into the Base Units in the main communication room. The fibers are then routed to each coverage locations where individual fibers terminate into splice boxes. The splice box couples the installed fiber into the remote units. Enough spare fibers should be installed to take into account future expansion of the system.

For example, for three remote units, six fibers are required. However, to allow for future upgrades, it is recommended to install additional optic fibers to be connected to additional RUs.

*Continued on the following page...*

The following figure illustrates fiber optic routing to Remote Cabinets.

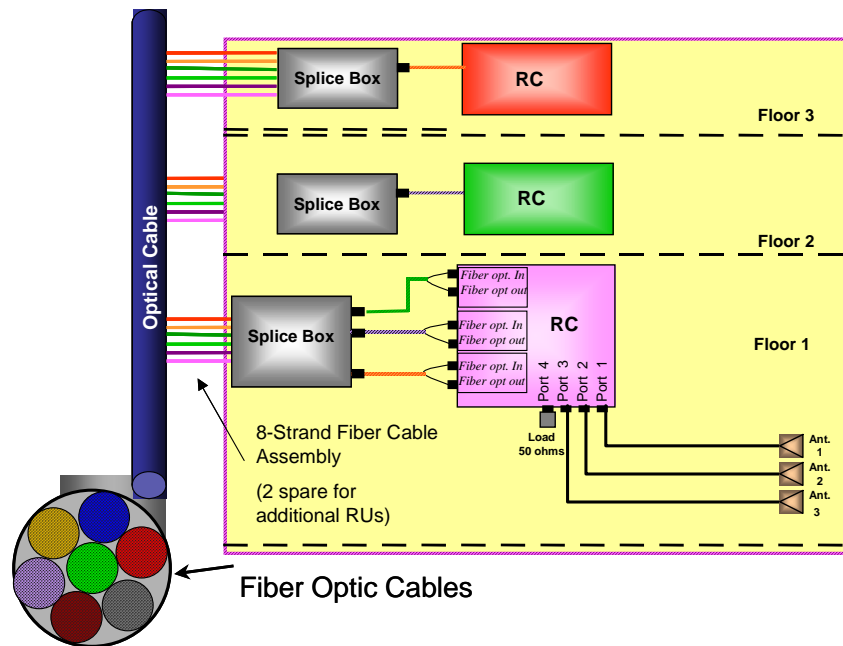

Figure 3-1. Illustration of Fiber Optic Routing

- **For remote power supply configuration** - cable bundles are routed from the main communication room and individual wire pairs are terminated into the power feed of individual units.

By providing power from a single distribution point, maintenance can be reduced and UPS backup can be easily provided. The maximum distance from the source to the termination spot is 1000 feet using 18 gauge wires.

In many locations local codes do not require power to be run through conduit if 100 watts or less is used. Please consult the regulations in your local jurisdiction prior to deploying remote power. When power cables require distances greater than 1000 feet 14 or 16 gauge wire may be used.

- **On each floor** - the antennas are connected to the Remote Cabinet or 2000 Lite system using coax cables.

# 4 System Installation

This chapter describes how the communication room and cabinet are installed. The individual system elements and connections are described in the Chapter 2.

---

**NOTE:** Be sure to read the installation requirements (see 3.2) and Power Consumption related instructions (see 3.3.4) before proceeding with the actual connections.

---

## 4.1 Pre-installation Instructions

In order to describe the installation process clearly, it will be described as consisting of two logical parts:

- A. **Telecommunications room** – installing the **RIUs, BUs, MA 410/430 controllers**, and the required *passive equipment* in the telecommunication room close to the RF signal source. This installation may differ between single and multi-building topologies.
- B. **Remote locations** – two types of installations:
  - MA 2000 Lite
  - RC Cabinet

The installations for two basic topologies are described in detail: for single building and for multi-building. By understanding the two generic installations you will be able to address any variations in system deployment.

---

**NOTE: For installations that include the MA NMS:** Once the installation has been completed, it can be verified using the **MCT** application (NMS User's Guide) and the devices monitored using the **NMS Manager** (NMS User's Guide).

---

### 4.1.1 Unpacking and Inspection

This section provides instructions for opening the shipping boxes, verifying that all parts have been received, and verifying that no shipping damage has occurred.

#### **Unpack and inspect the cartons according to the following procedure**

1. Open the shipping carton and carefully unpack each unit from the protective packing material.
2. Check for signs of external damage. If there is any damage, call your MobileAccess service representative.

## 4.2 Communication Room Installation

**The Communication Room installation consists of the following basic steps:**

1. Unpacking and inspecting the MA 2000 units (see 4.1.1)
2. Mounting the RIUs, BUs and 410/430 controllers in the mounting rack (see 4.2)
3. RF connections BTS/BDA connections.
4. RF connections to the Base Units.
5. Connecting the MA 410/430 control connections to the units
6. Connecting DC power to the units

### 4.2.1 Rack Installation General Instructions

---

**NOTE:** Usually, each operator installs the equipment that supports their services in a separate rack.

---

It is recommended to install the following MobileAccess system modules in a 19" rack in the communication room

- RIU Chassis 3U, RIU Lite 2U
- BU 1U
- MobileAccess 410/430 controller 1U
- Fiber Optic patch panel and splice tray
- Power supply/supplies (MobileAccess – 3U for each unit; units from other manufacturers may vary in size)

**Verify** that the rack height can support all the units to be installed, where you may also want to consider future expansions.

Figure 4-1 shows the recommended physical location of the MobileAccess elements in the rack in order to facilitate and simplify the cabling *connections*. The configuration is for a single operator. If the site is serviced by more than one operator, each operator often installs their equipment in a separate rack.

---

**NOTE:** Note that the **MobileAccess 430 controller** is at eye level to provide an easy view of the LED indicators and LCD display and easy access to the local and remote monitoring connections.

---



The following figure shows a typical installation for a two field design.

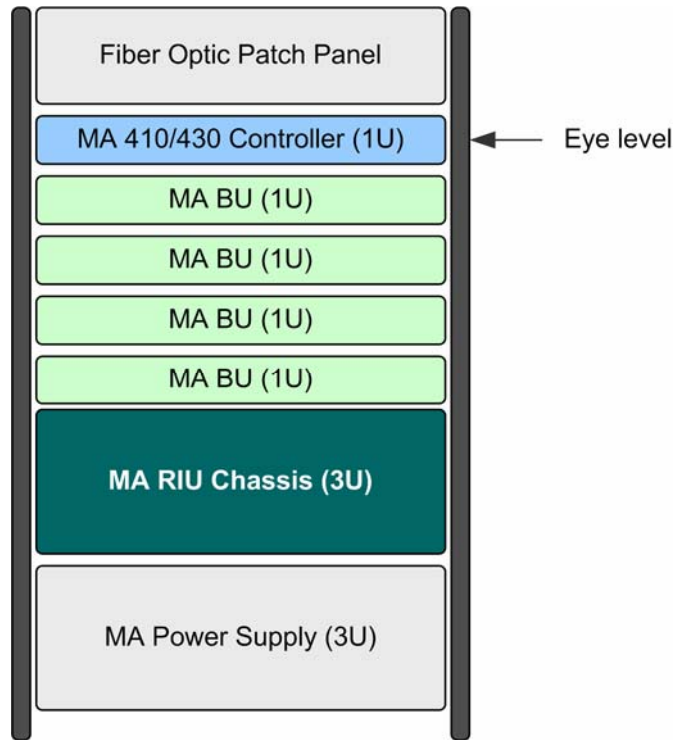

Figure 4-1: Recommended Order in the Communication Room Rack

## 4.2.2 Rack Installation Safety Instructions

Review the following guidelines to help ensure your safety and protect the equipment from damage during the installation.

- Only trained and qualified personnel should be allowed to install or replace this equipment.
- Verify that ambient temperature of the environment does not exceed 50°C (122°F)
- To maintain a low center of gravity, ensure that heavier equipment is installed near the bottom of the rack and load the rack from the bottom to the top.
- Ensure that adequate airflow and ventilation within the rack and around the installed components so that the safety of the equipment is not compromised. It is recommended to allow for at least about 2 cm of airspace between devices in the rack.
- Verify that the equipment is grounded as required – especially the supply connections.

## 4.2.3 BU Connections

This section describes the installation for the Base Units with the RF signal supplied from an MA RIU Lite. If an RIU system is installed, refer to the RIU Installation and Configuration Guide for detailed instructions on the RIU connections.

**NOTE:** It is assumed that the patch panel cabinet (SC/APC adaptors) for fiber optic cable connections is installed in the rack near the BUs.

**To connect the BU**

1. Connect fiber jumper between **splice tray** and **patch panel** cabinet.
2. Connect fiber jumpers between the corresponding **BU** optical ports and the **patch panel**.



Figure 4-2. BU Front Panel Connections

3. Connect the BU rear panel **Uplink** and **Downlink** ports to the corresponding ports on the RIU rear panel (or to the RF ports from the passive interface if your system does not include an RIU).
4. Connect the BU rear panel **COM** to the MA 430 rear panel RS485 connector.
5. Connect the **Power** connection on the BU rear panel.

The following figure shows the BU connections to an RIU Lite and MA 410/430 controller.

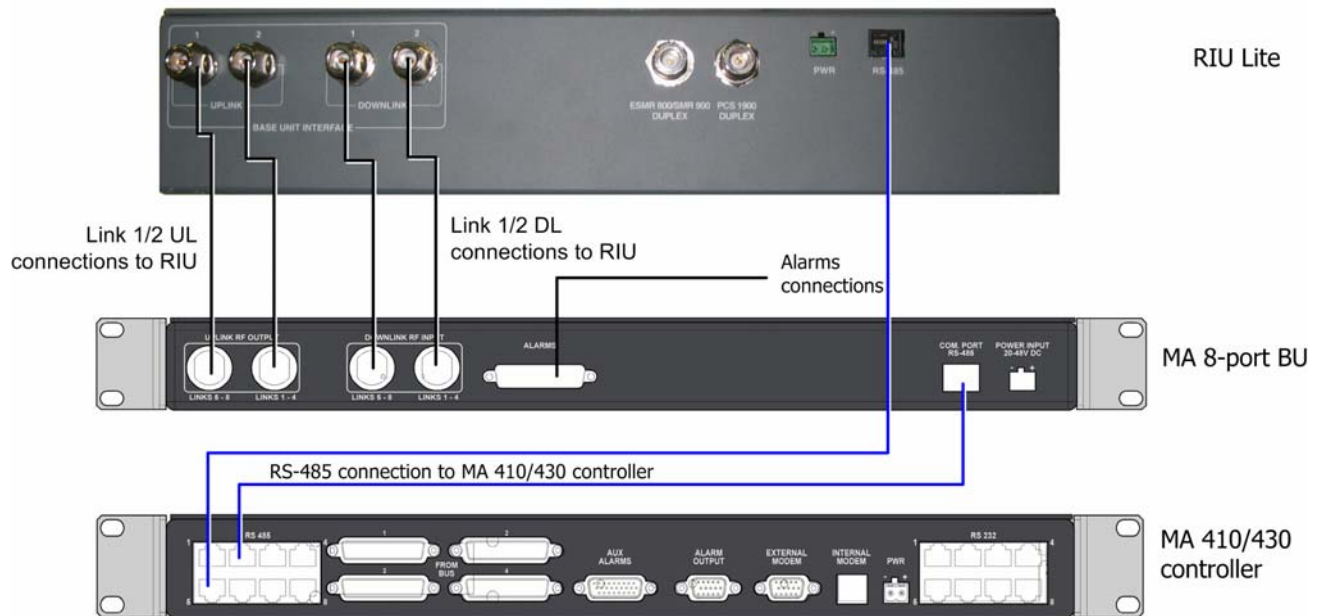

Figure 4-3. BU Rear Panel Connections

## 4.3 Remote Cabinet Installation

Mount and install the Remote Cabinet (RC) in one of the following configurations:

- Wallmount - on the wall in the communication room
- Rackmount – in a 19" rack in the *communication room* allocated to that area (sometimes referred to as a **secondary** communication room).

The procedure varies slightly according to the MA 2000 Cabinet model:

- Integrate power supply
- External power supply

The following sections describe both procedures.

---

**NOTE:** For installations that include MA 850/860 units, refer to the MA 850/860 Installation and Configuration Guide for instructions on various installation options with the MA 2000.

---

### 4.3.1 RC 2000 Wall Mount Installation

#### General Installation Instructions

- The MA 2000 Remote Cabinet units should be installed in a communication room that provides access to authorized personnel only. The units are maintenance free. In the event of failure, only authorized personnel should handle the units.
- Environmental Data - Maximum ambient operating temperature: 45° C
- Maximum ambient temperature in a rack: 45° C

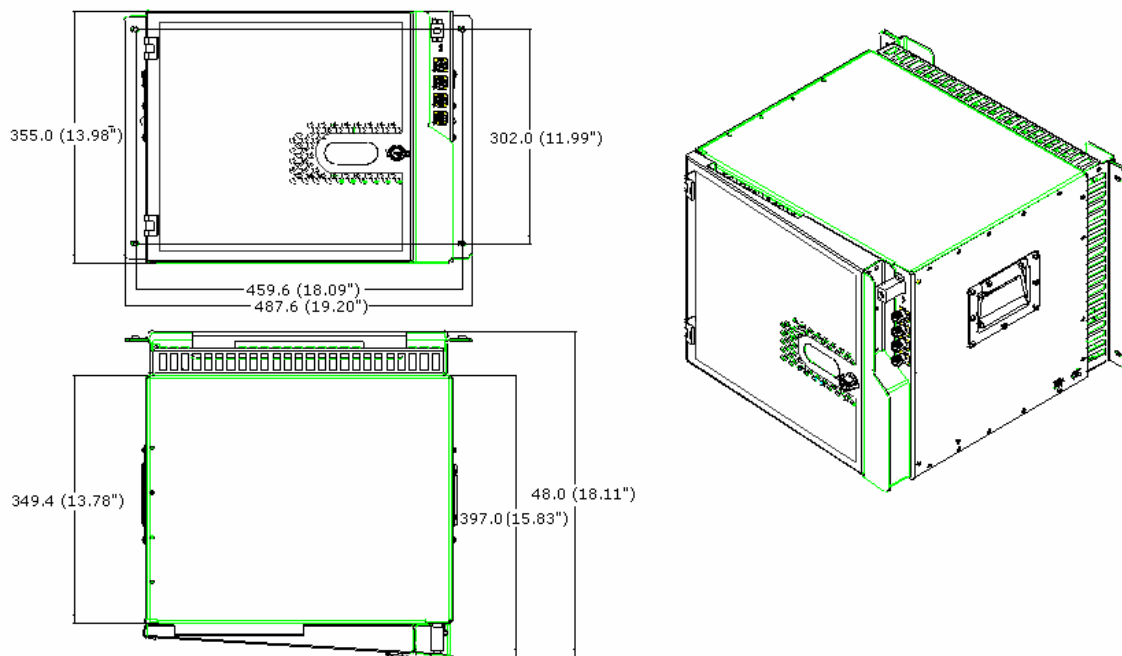

Figure 4-4. MA 2000 Cabinet Wallmount Dimensions

The wall installation 2000 Remote Cabinet is supplied with a plate that is to be mounted on the wall and a bracket that is assembled on the rear of the MA 2000 system.

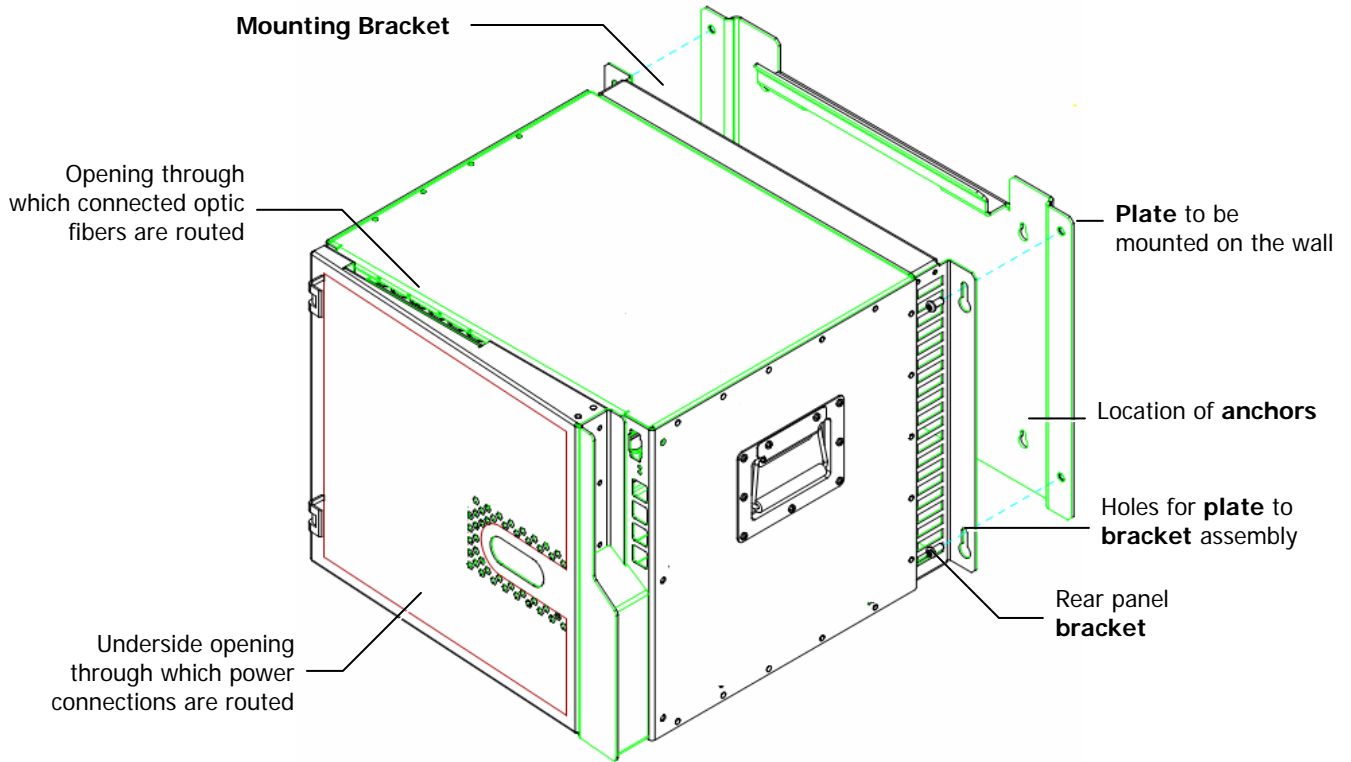

Figure 4-5. MA 2000 System Wall Mount

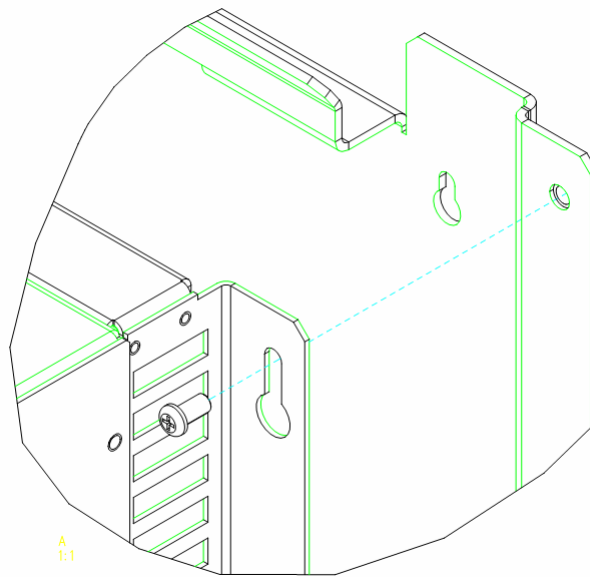

Figure 4-6. Zoom of Mounting Holes

**Mount the RC on the wall as follows:**

**ATTENTION:** The following instructions apply to an installation on a concrete wall. For any other type of wall, contact MobileAccess.

---

**NOTE:** For installations that include an MA 850/860 system, refer to the **MobileAccess 850/860 Installation and Configuration Guide**.

---

1. For **integrated power supply** configurations only (for other configuration grounding is optional), connect the cabinet GND according to section 4.3.2.
2. Using the **plate** as a guide, drill four holes for concrete anchors. Insert four concrete anchors (McMaster-Carr catalogue number 92403A200, or equivalent).
3. Mount the **Plate** on the wall. Carefully and thoroughly fasten the anchors to the wall.
4. Assemble the **Bracket** onto the rear of the Remote Cabinet using the supplied screws.
5. Lift the MA 2000 RC and guide the rear ledge of the assembled bracket onto the **plate bracket**.
6. Using the four screws, secure the RC **Bracket** to the **Plate** on the wall.

---

**NOTE:** Tighten the screws only as much as needed to secure the Bracket to the Plate. One should be able to loosen the screws quickly if needed.

---

### 4.3.2 RC Grounding - Integrated PS Wall Mount Model

**NOTE:** This procedure is only necessary for wall mount integrated power supply configuration (for other configurations this procedure is optional).

The Ground screw is located at the rear of the unit.



Figure 4-7: Grounding Located at the Rear of the Unit

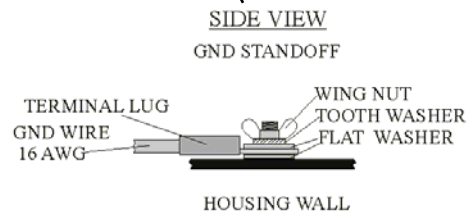

### 4.3.3 RC 2000 Rack Mount Installation

**NOTE:** The cabinet requires a clearance of 10 cm above the unit. If a heating source is installed beneath the MRC, a buffer must be placed between the cabinet and the surface.

The following figure provides the dimensions for the MA 2000 Rack Model.

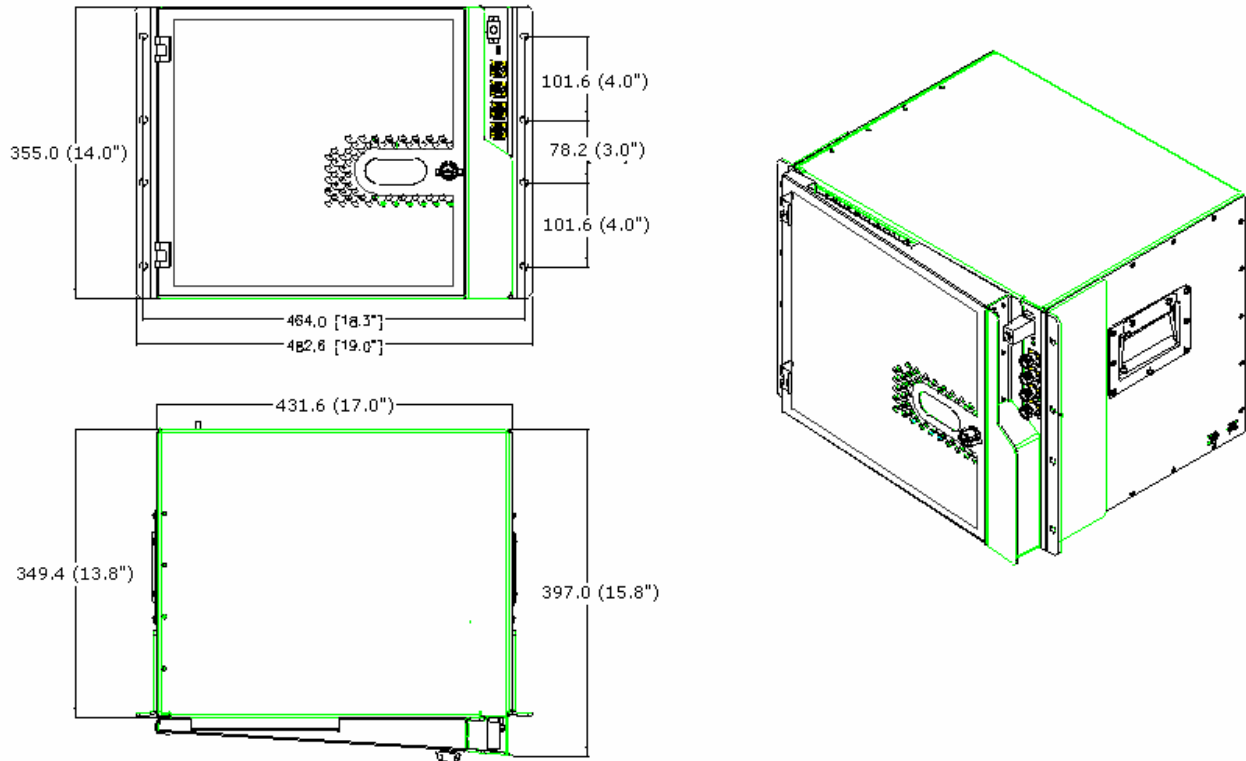

Figure 4-8. MA 2000 Cabinet Rack Mount Assembly

The MA 2000 RC Rack Mount model is supplied with the required brackets already assembled to the sides of the cabinet as illustrated in the Figure 4-9 . MA 2000 RC Rack Model.

Simply, mount the MA 2000 RC in the rack and secure with the supplied screws.

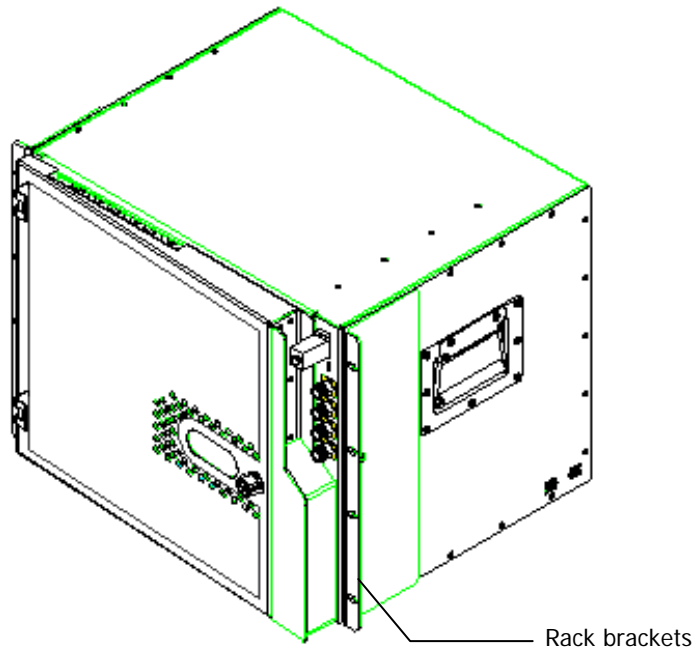

Figure 4-9 . MA 2000 RC Rack Model



### 4.3.4 Fiber Optic Connections

---

**NOTE:** Keep in mind the rules for handling and connecting F/O cables. The F/O cables will be connected to the associated BU in the communication room at a later phase.

---

1. Install splice box near Remote Cabinet.
2. Connect fiber optic cable to splice box and the SC/APC pigtails to each RU 2000 module.
3. For the downlink, connect the fiber optic cable pigtails from splice box coming from the BU port to the corresponding RU port (routing the optic fibers so they will fit through the top opening in the door.)
4. For the uplink, connect the fiber optic cable pigtails from splice box from the RU (routing the optic fibers so they will fit through the top opening in the door), to the uplink port that connects to the BU.

**The internal power connections and other connections should already be connected.**

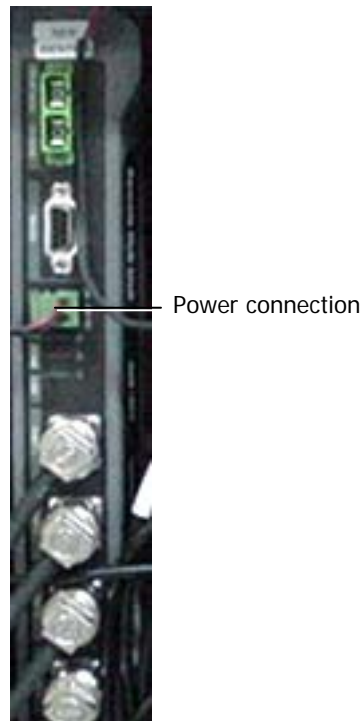

*Figure 4-10. RU 2000 Fiber Optic and internal power connections*

## 4.3.5 Power Connections

The power connections vary depending on whether the configuration is for an integrated power supply or for external power supplies.

### 4.3.5.1 Integrated Power Supply model

- Connect the AC power connector to the connector on the internal plate as illustrated below. The power source may be: 230 VAC, 115 VAC (an AC/DC converter is built into the chassis).
- You may also connect a **backup battery of 48V** to the battery connector. This is an optional connection.

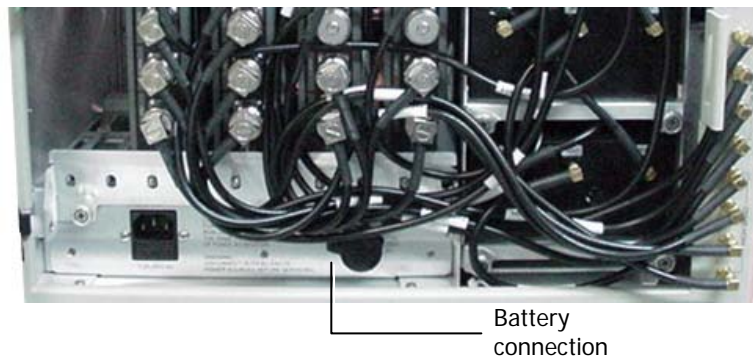

Figure 4-11. Partial View of system illustrating location of power connections

### 4.3.5.2 External Power Supplies Model

The external power source may be a central source with cables routed to each RU, or RU dedicated power supplies locally installed.

- PS = 24 VDC to 48 VDC.
- Connect each power connection to the appropriate connector on the remote cabinet.

## 4.3.6 Antenna Connections

- For systems *without* MA 850/860 modules - connect the antenna connections to the RC antenna ports
- For systems with MA 850/860 modules - refer to *MA 850/860 Installation Manual*

## 4.4 MA 2000 Lite Installation and Connections

MA 2000 is designed as a wall-mount installation – usually located in the communication shaft of the corresponding floor. The remote units are mounted externally to the 2000 Lite device and their antenna outputs are connected to either side of the 2000 Lite device. The combined outputs are then connected to the antennas in the covered area.

The following figure illustrates MA 2000 connections to two RUs.

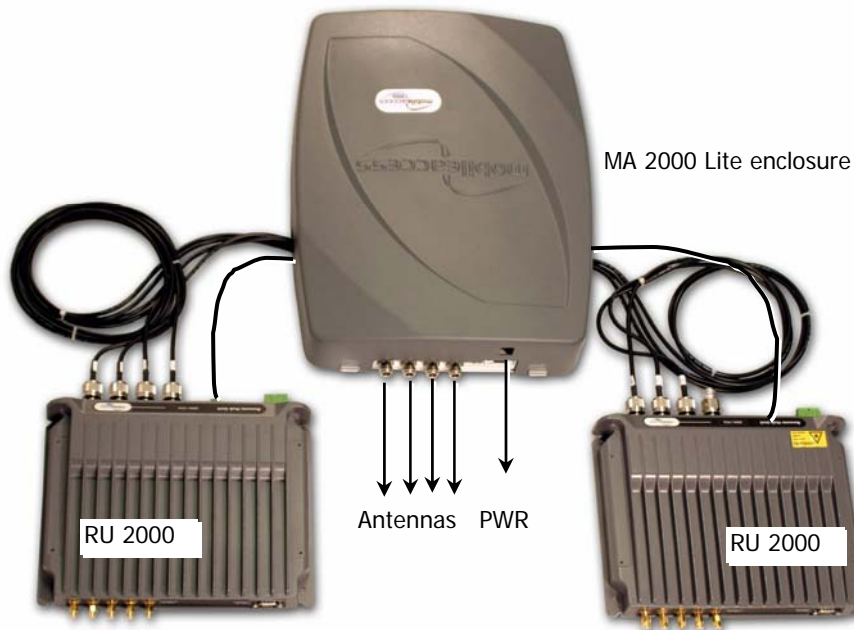

Figure 4-12. 2000 Lite System Coax Connections

The following figure shows the RIU Lite mechanical drawing

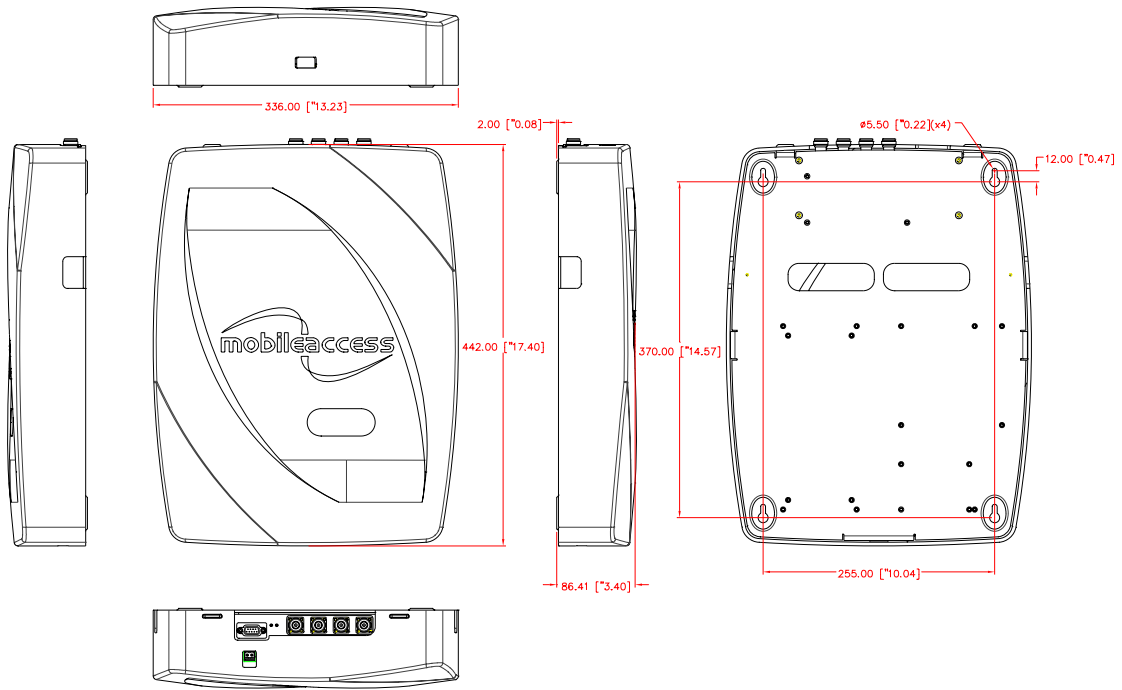

Figure 4-13. MA 2000 Lite Mechanical Dimensions

### 4.4.1 Mounting MA 2000 Lite

In order to mount MA 2000 Lite on the wall, the cover is first removed, the tray and all installed elements are secured to the wall and the top cover assembled again.

1. Remove the top cover by pulling it towards the rear bracket and lifting it over the front brackets. The tray and all its assembled components are displayed. The installed filters vary depending on the RU models in the installation.

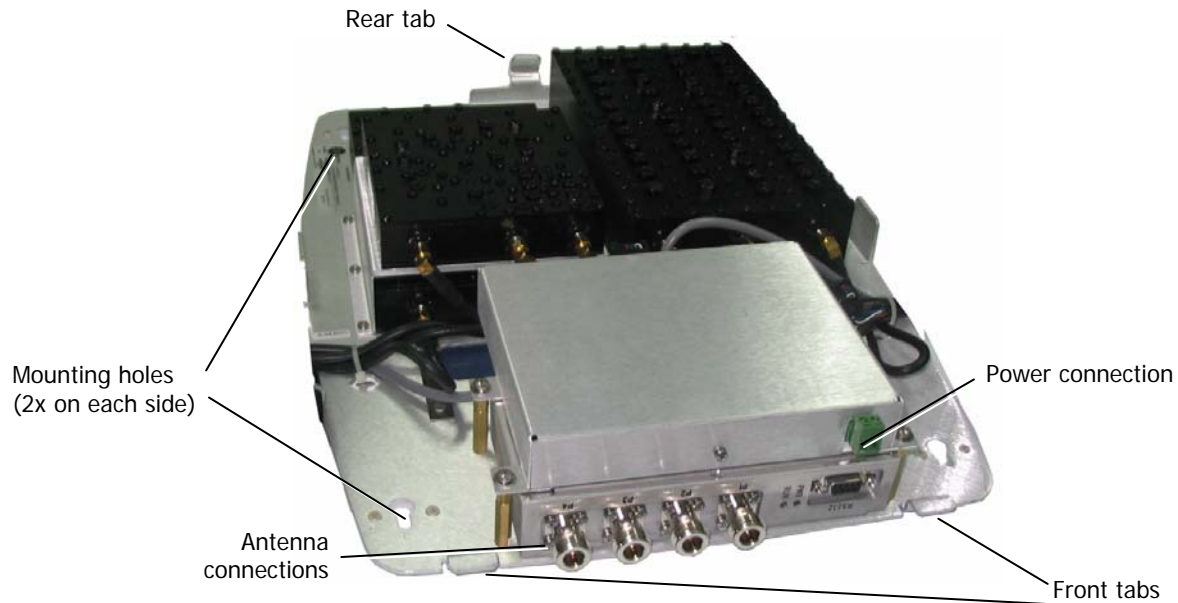
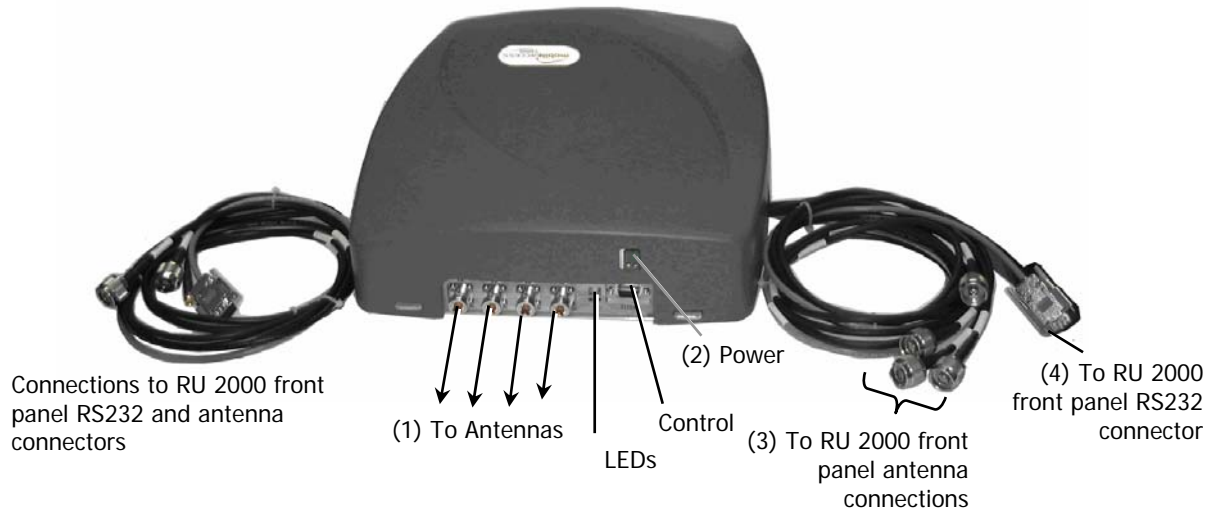

Figure 4-14. MA 2000 Lite Prepared for Mounting

2. Depending on the tools you use:
  - Either measure the distance between the four wall mount holes and drill the required holes in the wall and insert the screws, or
  - Hold the tray up against the wall and simply drill the screws in the holes.
3. Mount each RU 2000 on the wall, on the corresponding side of the MA 2000 Lite unit.
4. Reassemble the MA 2000 Lite cover by fitting it over the *front tabs* and pressing down gently at the rear.

## 4.4.2 MA 2000 Lite Connections

This section describes the MA2000 Lite enclosure and its' external connections.



---

**NOTE:** It is not required to perform the following procedures in any particular order.

---

1. Connect the antenna cables to the front panel **antenna** connectors.
2. Connect the **DC power**.
3. Connect each of the **side cable** N-type antenna connectors to the antenna connectors of the corresponding RU.
4. Connect each of the **side cable** D-type connector to the front panel RS232 connectors of the corresponding RU.

# 5 Upgrading and Configuration Examples

**MA 2000** provides an entry level cost effective solution for current services and support for future services from the same or different operators. Support for additional bands is implemented by an RU module and RU specific hardware designed to prevent interference with other existing bands in the coverage area.

For support for additional services, connect the corresponding RU and hardware (Cavity Filter, Duplexer, etc.) to the **8x4 Module** and to the external coax infrastructure.

---

**NOTE:** It is required to order an Accessory Kit for each new unit to be added to the installation. The kit includes cables for connecting the RU 2000 or MA 1200 add on units to the required filters. Because of the differences in cable length requirements, the accessory kit differs for units designated to be installed in 2000 Cabinets and for those designated to be installed with MA 2000 Lite systems. **Be sure to order the appropriate kit as detailed in section 0 .**

---

This chapter provides several examples of the most common configurations and their connections. As systems are upgraded, refer to the provided diagrams for a description of the connections between the **Remote Units** (referred to as RU or RU 2000), the **interface devices** (Filters, etc.) and the **4x8 Combiner**.

# 5.1 Common USA Configurations

## 5.1.1 iDEN/SMR with PCS Add-on

iDEN and SMR coverage is implemented by one remote unit. This type of configuration was designed to meet Nextel's existing needs. MA 1200 add-on module for PCS support can be integrated into the solution at any time in order to meet future needs.

The following figure describes the port connections between the remote units, add-on, and 8x4 Combiner.

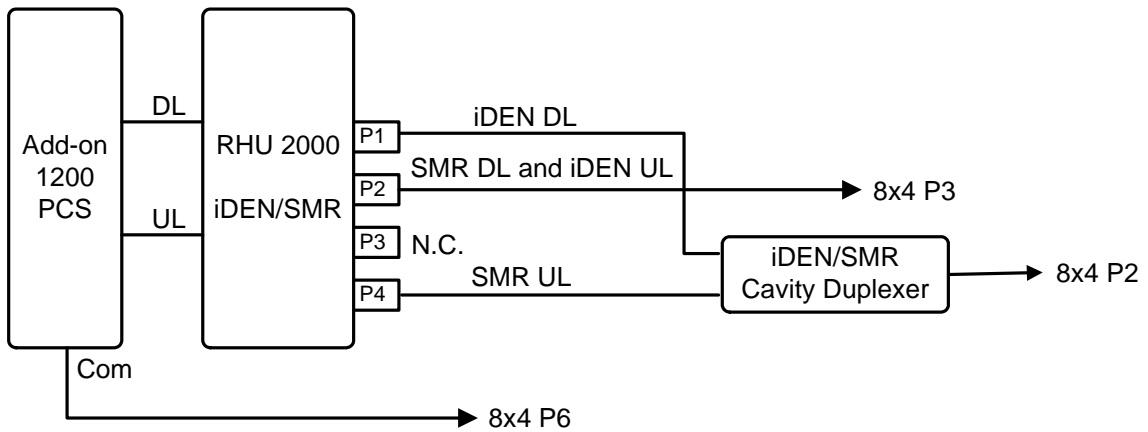

Figure 5-1. iDEN/SMR and PCS Connections



### 5.1.2 Cell/PCS

For infrastructures supporting a single Cell band and PCS, connect the RU according to the following figure.

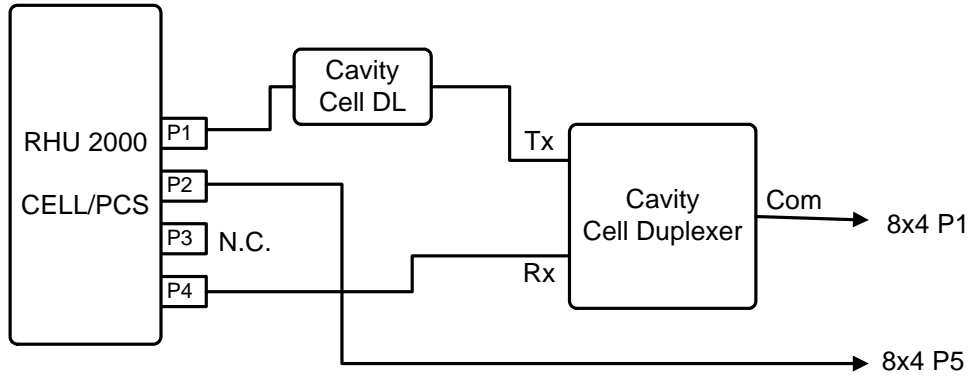

Figure 5-2. Single Cell/PCS Connections

For infrastructures supporting two Cell bands and a PCS band, connect the second Cell/PCS services RU according to the following figure.

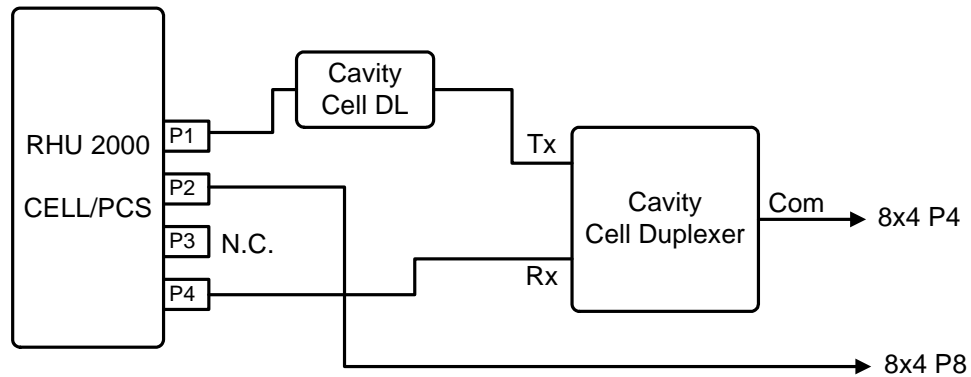

Figure 5-3. Additional Cell/PCS Connections

## 5.2 Typical International Configurations

MA 2000 Lite supports Cell/DCS and DCS. UMTS support can be added through MA 1200 Add-on.

### 5.2.1 Typical Asian Configuration: Cell/DCS+ UMTS

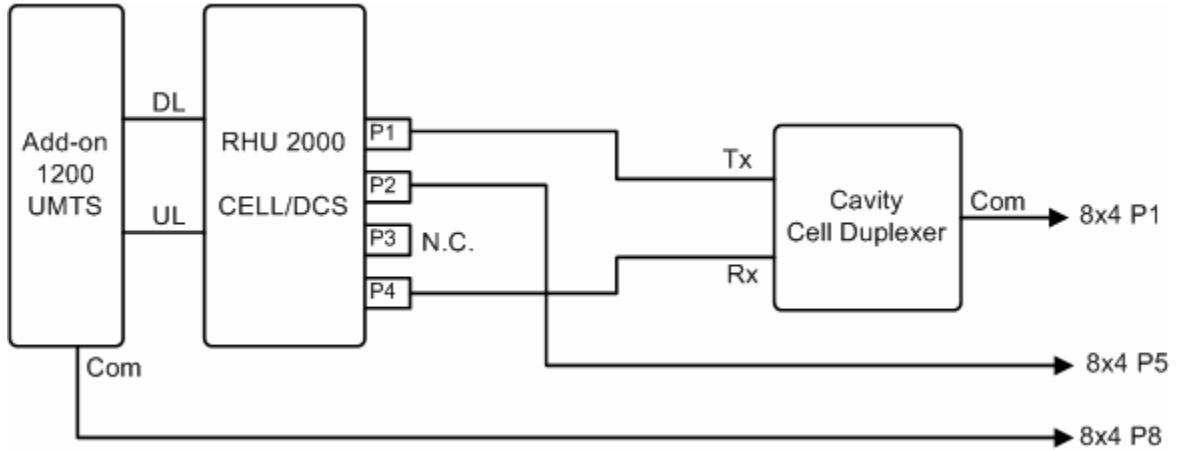

Figure 5-4. Cell/DCS and UMTS Configuration

### 5.2.2 Typical European & Middle East Configuration: EGSM/DCS + UMTS Configuration

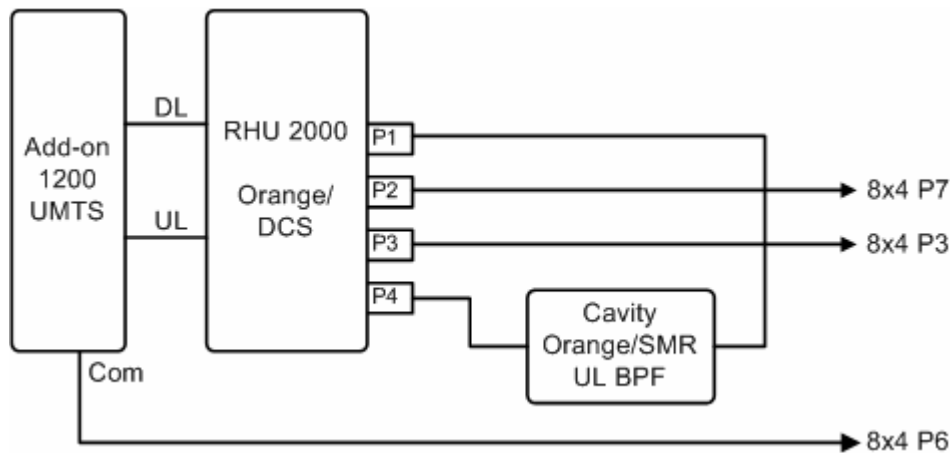
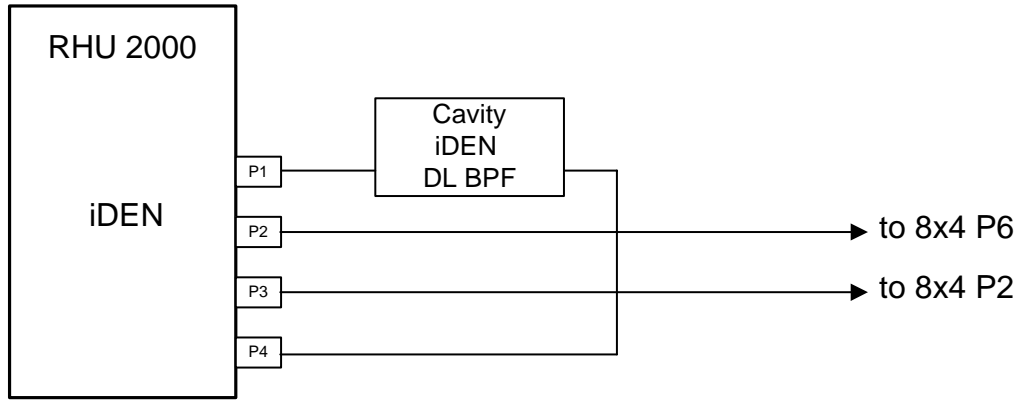

Figure 5-5. Typical European & Middle East Configuration

### 5.2.3 iDEN

iDEN support is provided through MA 2000 Cabinet configurations.



5-6. iDEN Configuration

### 5.3 2000 Lite Cell/DCS and GSM/DCS Config for Telstra

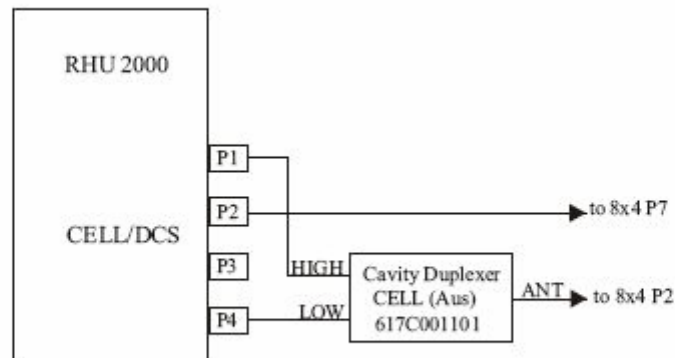
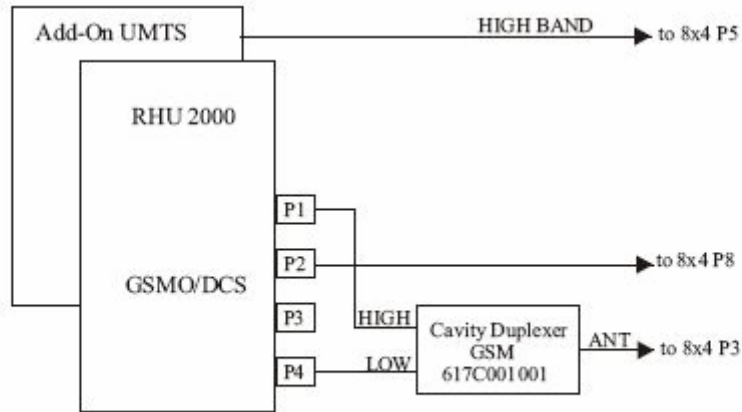

# 6 Appendix : System Specifications

## RF Parameters

### RF Frequency Range

Services	Frequency Range	
	Uplink	Downlink
CELL	824-849	869-894
iDEN	806-824	851-869
GSM	890-915	935-960
E-GSM	880-915	925-960
Telstra 850M	824-849	869-890
SMR	896-902	929-941
DCS	1710-1785	1805-1880
PCS	1850-1910	1930-1990
G-PCS	1850-1915	1930-1995
UMTS 2100	1920-1980	2110-2170

## Low Band

RF Parameters Low Band												
RU 2000	CELL TDMA/CDMA/WCDMA		SMR 800		iDEN 800 Sprint		GSM/ E- GSM		SMR 900		iDEN 900 Sprint	
	D	U	D	U	D	U	D	U	D	U	D	U
Max output PWR per antenna port												
1 (comp)	<b>16</b>		14		10		12		14		10	
2 carriers	<b>13</b>		11		7		9		11		7	
4 carriers	<b>10</b>		8		4		6		8		4	
8 carriers	<b>7</b>		5		1		3		5		1	
12 carriers	<b>5</b>		3		-1		1		3		-1	
Mean Gain(dB)*	<b>16</b>	7	14	7	10	7	12	7	14	<b>7</b>	10	7
Pin (dBm)*	<b>0</b>		0		0		0		0		0	
Input IP3 (dBm) AGC OFF Min		-5		-5		-5		-5		-5		-5
Input IP3 (dBm) AGC ON Min		5		5		5		5		5		5
SFDR** (dB)		71		72		72		64		71		71
Max Intermod Distortion (dBm)	<b>-13</b>		-13		-13		-36		-13		-13	
Max Nf (dB)		20		20		20		20		20		20
Gain Flatn. (dB)							± 2.0					

## High Band

\*Factory set mean gain BU-RHU without RIU. May be field adjusted using system controller.

\*\* SFDR for CDMA services is calculated in 100Kb/sec

RF Parameters High Band						
RU 2000	DCS		PCS CDMA/WCDMA		PCS GSM/TDMA	
	D	U	D	U	D	U
Max output PWR per antenna port						
1 (comp)	14		14		16	
2 carriers	11		11		13	
4 carriers	8		9		10	
8 carriers	5		6		7	
12 carriers	3		4		5	
Mean Gain(dB)*	14	3	14	3	14	3
Pin (dBm)*	0		0		2	
Input IP3 (dBm) AGC OFF Min		-6		-6		-6
Input IP3 (dBm) AGC ON Min		3		3		3
SFDR** (dB)		64		66		64
Max Intermod Distortion (dBm)	-30		-13		-13	
Max Nf (dB)		20		20		20
Gain Flatn. (dB)				± 2.0		

## RF Parameters 1200 Add-on

1200 ADD-ON	G-PCS CDMA/WCDMA		G-PCS GSM/TDMA		UMTS***	
	D	U	D	U	D	U
Max output PWR per antenna port						
1 (comp)	20		21		21	
2 carriers	17		18		18	
4 carriers	14		15		15	
8 carriers	11		12		12	
12 carriers	9		10		10	
Mean Gain(dB)*	20	3	20	3	21	3
Pin (dBm)*	0		1		0	
Input IP3 (dBm) AGC OFF Min		-7		-7		-7
Input IP3 (dBm) AGC ON Min		3				3
SFDR** (dB)	66		64		66	70
Max Intermod Distortion (dBm)	-13		-13		***	
Max Nf (dB)		20		20		20
Gain Flatn. (dB)	± 2.0					

\*Factory set mean gain BU-RHU without RIU. May be field adjusted using system controller.

\*\* SFDR for CDMA services is calculated in 100Kb/sec

\*\*\* UMTS Compiles with 3GPP TS 25.106 V5.0.0 (2002-03) Table 9.4 spectrum emission mask



# System Specs

<b>Fiber Optic Specifications</b>	
Optical output power	<3.0mW
Max. Optical budget	2 dB for fiber + 1 dB for connectors (assumed) = 3 dB total
Optical loss per mated-pair connectors	0.5dB (max)
Optical Connector	SC/APC
Fiber type	9/125 SM
Wavelength	1310±10nm
Maximum distance between Base Unit and Remote Cabinet	2Km

<b>Absolute Maximum Rating</b>	
Total Input RF Power to BU	10dBm
Total Input RF Power to RU	20dBm out-of-band -10dBm in-band
Power Supply VDC	60VDC

<b>Temperature Specifications</b>	
Operating	0°C to +50°C (32°F to 122°F)
Storage	-20°C to 85°C (-4°F to 185°F)

# Specifications of Units

## MA 2000 MRC Remote Hub

Supported Units	: A total of up to five Remote Units (one being a MA 1200 Add-on module) (not including MA 850/860 which is installed externally)
RF antenna connections	: Four N-type female antenna connections
Input power	
Local powering	: 230 VAC, 115 VAC (an AC/DC converter is built into the chassis).
Remote powering	: 20 to 48VDC to external connectors on chassis
Power consumption	: 25W
Physical	
Mounting	: Wallmount and rackmount
Dimensions	: 355 x 482.6 x 397mm (13.97" x 19" x 15.63" )
Weight (4 modules)	: ~35Kg (~77 lb)

## MA 2000 Lite

Supported Units	: External connections to two Remote Units (MA 1200 Add-ons each unit)
RF antenna connections	: Four N-type female antenna connections
Power consumption	: 3W max (housing only with no remote units)
Physical	
Mounting	: Wallmount
Dimensions	: 442 x 336 x 86.41mm (17.4" x 13.23" x 3.4" )
Weight	: 5.5Kg (12.1lb)

## MA 2000 Remote Unit

Supported services	: Two services corresponding to the model
Power:	
Input power	: 20 to 48V DC
Power consumption	: 29W
RF connections	: To Antenna (via hub) - N-type Female, 50 ohm : To MA 1200 add-on - SMA 50 ohm
Optic connections	: SC/APC optic connections
Remote management	: SNMP, NMS via Base Unit connection to MA 410/430 controller.

## MA 1200 Add-On Specifications

Supported services	: Single service corresponding to the model
RF Connections:	: To RHU - SMA 50 ohm
Power:	
Input power	: 25-48VDC
Power consumption	: 50W
Remote management	: SNMP, NMS via RHU connection
Dimensions	27.9x22.0x6.9cm (10.98"x8.66"x2.71")
Weight	2.8Kg (6.2 lb)

## Base unit Specifications

Models:	4-port model, 8-port model (shown above)
Supported services:	Wideband device supporting all services supported by MA systems
RF (total Input):	10 dBm max
Power:	
Input power	20 to 48V DC
Power consumption	14W (8-port BU)
RF connections	N-type Female, 50 ohm – interface to RIU or to passive BTS interface N-type Female, 50 ohm – interface to antennas
Optic connections	Four or eight (depending on the model) SC/APC optic connections
Remote management	SNMP, NMS via connection to MA 410/430 controller.
Physical	
Dimensions	48.26x4.44x29.97cm (19"x1Ux11.8")
Weight	2.82Kg (6.2lb)

## Ordering Information

**NOTE:** The information listed below is updated up to the document publishing date. Refer to the MA2000 datasheet for the most updated ordering information.

<b>Remote HUBs</b>	
2000-RC-RP	Remote Cabinet - all services, Remote powering
2000-RC-LP	Remote Cabinet - all services, Local powering
2000-MINI-ENC	2000 enclosure supporting 2 modules
<b>Dual Band RF Modules, add-on ready</b>	
<b>2000 Cabinet</b>	
2000-CELL-DCSE	Dual band Cell/DCS 1 port for cabinet, enhanced power
2000-CELL-PCSE	Dual band Cell/PCS 1 port for cabinet, enhanced power
2000-GSMO-DCSE	Dual band GSM DCS 1port for cabinet, enhanced power
2000-IDEN-SMR	Dual band iDEN/SMR for cabinet
2000-E-GSM-DCS	Dual band EGSM/DCS 1 port for cabinet
<b>2000 Lite</b>	
2000-CELL-DCSEL	Dual band Cell/DCS 1 port for Lite, enhanced power
2000-CELL-PCSEL	Dual band Cell/PCS 1 port for Lite, enhanced power
2000-E-GSM-DCSL	Dual band GSM/DCS 1 port for Lite, enhanced power
2000-GSMO-DCSEL	Dual band GSM DCS 1 port for Lite, enhanced power
2000-IDEN-SMR-L	Dual band iDEN/SMR for Lite
	Dual band Cell/DCS 1 port for Lite enhanced power for Telstra

2000-CELL-DCSLT	Dual band GSM/DCS 1 port for Lite enhanced power for Telstra
2000-GSM-DCSLT	
<b>MobileAccess 1200 Add On</b>	
1200-PCS-AO-CB	Add-on RHU - PCS service for cabinet
1200-G-PCS-AO-CB	Add-on RHU supporting a PCS w/G-block for 2000 cabinet
1200-UMTSE-AO-CB	Add-on RHU - UMTS service for cabinet
1200-PCS-AO-LT	Add-on RHU - PCS service for Lite
1200-UMTSE-AO-LT	Add-on RHU - UMTS service for Lite

<b>MobileAccess Universal Base Units</b>	
WB-B8U	Wide Band Base 8 Unit supporting 8 RHUs
WB-B4U	Wide Band Base 4 Unit supporting 4 RHUs

<b>Network Controller</b>	
410	Network Controller – Serial Interface (dial-up)
430	Network Controller –Ethernet/IP Interface

<b>Network Management System</b>	
NMS-SW-SERVER	GUI and server S/W package (one per site)
NMS-SW-MFEE	NMS annual S/W maintenance fee (per 430-CTRL)

<b>MobileAccess Radio Interface Unit (RIU)</b>	
RIU-IM	Radio Interface Unit
RIU-BTSC-CELL	BTS Conditioner for Cellular
RIU-BTSC-IDEN	BTS Conditioner for iDEN
RIU-BTSC-PCS	BTS Conditioner for PCS
RIU-BTSC-G-PCS	BTS Conditioner for PCS w/ G-Block support
RIU-BTSC-SMR	BTS Conditioner for SMR-Paging
RIU-BTSC-GSM	BTS Conditioner for GSM 900MHz
RIU-BTSC-E-GSM	BTS Conditioner for EGSM 900MHz
RIU-BTSC-DCS	BTS Conditioner for DCS 1800MHz
RIU-BTSC-UMTS	BTS Conditioner for UMTS 2100MHz
RIU-BDAC-CELL	BDA Conditioner for Cellular
RIU-BDAC-IDEN	BDA Conditioner for iDEN
RIU-BDAC-PCS	BDA Conditioner for PCS
RIU-BDAC-G-PCS	BDA Conditioner for PCS w/ G-Block support
RIU-BDAC-SMR	BDA Conditioner for SMR-Paging
RIU-L-IDEN-SMR-G-PCS1	RIU Lite for iDEN800,SMR 900,PCS1900 w/G-Block, support 1BU8
RIU-L-CELL-PCS1	RIU Lite Cellular 800,PCS 1900

<b>Power Supply</b>	
LPS-48V-66W	Local AC/DC Converter 66W
LPS-48V-100W	Local AC/DC Converter 100W
AK-PWR-CORD-EU	AC Power cord for 66W & 100W power supplies, European connector
AK-PWR-CORD-UK	AC Power cord for 66W & 100W power supplies, UK connector

*This page is intentionally left blank...*