



# **MobileAccessVE Dual-Band Instant Coverage Solution User Manual**

**P/N: 709C004902  
REV: A01  
Date: MAY 2010**

A green wavy border is at the bottom of the page.

**MobileAccess Worldwide Headquarters**

8391 Old Courthouse Road Suite 300, Vienna, VA 22182

Tel: +1(866)436-9266, +1(703)848-0200 TAC: +1(800)787-1266, Fax: +1(703)848-0280

<http://www.MobileAccess.com>

# Preface Material

© Copyright 2010, MobileAccess Networks Inc. All Rights Reserved.

This document contains confidential and proprietary information of MobileAccess and may not be copied, transmitted, stored in a retrieval system or reproduced in any format or media, in whole or in part, without the prior written consent of MobileAccess. Information contained in this document supersedes any previous manuals, guides, specifications, data sheets or other information that may have been provided or made available to the user.

This document is provided for informational purposes only, and MobileAccess does not warrant or guarantee the accuracy, adequacy, quality, validity, completeness or suitability for any purpose of the information contained in this document. MobileAccess reserves the right to make updates, improvements and enhancements to this document and the products to which it relates at any time without prior notice to the user. MOBILEACCESS MAKES NO WARRANTIES, EXPRESS OR IMPLIED, INCLUDING, WITHOUT LIMITATION, THOSE OF MERCHANTABILITY AND FITNESS FOR A PARTICULAR PURPOSE, WITH RESPECT TO THIS DOCUMENT OR ANY INFORMATION CONTAINED HEREIN.

## Policy for Warrantee and Repair

MobileAccess tests and inspects all its products to verify their quality and reliability. MobileAccess uses every reasonable precaution to ensure that each unit meets their declared specifications before shipment. Customers should advise their incoming inspection, assembly, and test personnel about the precautions required in handling and testing our products. Many of these precautions can be found in this manual. The products are covered by the following warranties:

### General Warranty

MobileAccess warrants to the original purchaser all standard products sold by MobileAccess to be free of defects in material and workmanship for one (1) year from date of shipment from MobileAccess. During the warranty period, MobileAccess will repair or replace any product that MobileAccess proves to be defective. This warranty does not apply to any product that has been subject to alteration, abuse, improper installation or application, accident, electrical or environmental over-stress, negligence in use, storage, transportation or handling.

### Specific Product Warranty Instructions

All MobileAccess products are warranted against defects in workmanship, materials and construction, and to no further extent. Any claim for repair or replacement of units found to be defective on incoming inspection by a customer must be made within (30) days of receipt of shipment, or within (30) days of discovery of a defect within the warranty period.

This warranty is the only warranty made by MobileAccess and is in lieu of all other warranties, expressed or implied. MobileAccess sales agents or representatives are not authorized to make commitments on warranty returns.

## Returns

In the event that it is necessary to return any product against above warranty, the following procedure shall be followed:

1. Return authorization is to be received from MobileAccess prior to returning any unit. Advise MobileAccess of the model, serial number, and discrepancy. The unit may then be forwarded to MobileAccess, transportation prepaid. Devices returned collect or without authorization may not be accepted.
2. Prior to repair, MobileAccess will advise the customer of our test results and any charges for repairing customer-caused problems or out-of-warranty conditions etc.
3. Repaired products are warranted for the balance of the original warranty period, or at least 90 days from date of shipment.

## Limitations of Liabilities

MobileAccess's liability on any claim, of any kind, including negligence for any loss or damage arising from, connected with, or resulting from the purchase order, contract, quotation, or from the performance or breach thereof, or from the design, manufacture, sale, delivery, installation, inspection, operation or use of any equipment covered by or furnished under this contact, shall in no case exceed the purchase price of the device which gives rise to the claim.

EXCEPT AS EXPRESSLY PROVIDED HEREIN, MOBILEACCESS MAKES NO WARRANTY, EXPRESSED OR IMPLIED, WITH RESPECT TO ANY GOODS, PARTS AND SERVICES PROVIDED IN CONNECTION WITH THIS AGREEMENT INCLUDING, BUT NOT LIMITED TO, THE IMPLIED WARRANTIES OF MERCHANTABILITY AND FITNESS FOR A PARTICULAR PURPOSE. MOBILEACCESS SHALL NOT BE LIABLE FOR ANY OTHER DAMAGE INCLUDING, BUT NOT LIMITED TO, INDIRECT, SPECIAL OR CONSEQUENTIAL DAMAGES ARISING OUT OF OR IN CONNECTION WITH FURNISHING OF GOODS, PARTS AND SERVICE HEREUNDER, OR THE PERFORMANCE, USE OF, OR INABILITY TO USE THE GOODS, PARTS AND SERVICE.

## Reporting Defects

The units were inspected before shipment and found to be free of mechanical and electrical defects. Examine the units for any damage that may have been caused in transit. If damage is discovered, file a claim with the freight carrier immediately. Notify MobileAccess as soon as possible.  
**NOTE:** Keep all packing material until you have completed the inspection

## Safety Warnings

To comply with FCC RF exposure compliance requirement, adhere to the following warnings:

**Warning!** The Access Pod with its built-in antenna must be installed with a separation distance of at least 20cm from all persons and must not be located in conjunction with any other antenna.

**Warning!** The outside antenna must be installed with a separation of at least 20cm from all persons and must not be located in conjunction with any other antenna.

**Warning!** Use of this Access Pod with antennas other than those illustrated could be hazardous. Before using other antennas, contact MobileAccess Support.

**Caution:** Double pole/neutral fusing (two fuses in the appliance inlet)

## Approved Antennas for use with the MobileAccessVE Solution

The gain of external antennas connected to the VAPs should not exceed 10 dBi.

## Compliance with RF Safety Requirements

MobileAccess products have no inherent significant RF radiation. The RF level on the down link is very low at the downlink ports. Therefore, there is no dangerous RF radiation when the antenna is not connected.

## Certification and Compliance to Standards

Category		Standards
<b>Safety:</b>		IEC 60950-1: 2003; UL-60950-1:2003; CAN/CSA – C22.2 No 60950-1-03
<b>EMC:</b>		EN 301489-8 V1.2.1:2002; EN 301489-1 V1.5.1:2004; EN 61000 V4.6:2005 EN 55022 V4.2:2001 / FCC Part 15; VCCI Class A for VCU and Class B for VAP
<b>Radio:</b>	<b>GSM/DCS -</b>	EN-301502 V8.1.2: 2001; EN-301908 v3.2.1:2006; EN 300 609-4 V8.02:2000
	<b>CELL/PCS -</b>	FCC Part 24
	<b>UMTS -</b>	EN 301 908-11
<b>SAR Body Testing</b>		EN 50385 & FCC OET65C:2001

## About This Guide

This guide provides essential product functionality with all the information necessary for proper installation and configuration of the MobileAccess**VE** system.

## List of Acronyms

<b>Abbreviation</b>	<b>Description</b>
DB	Dual-Band
PoE	Power Over Ethernet
PSE	Power Sourcing Equipment
SME	Small / Medium Enterprise
STP	Shielded Twisted Pair
UTP	Unshielded Twisted Pair
VAP	VE Access Pod
VCU	VE Control Unit
UMTS	Universal Mobile Telecommunications System
EGSM	Extended Global System for Mobile Communications
PCS	Personal Communications Service
DCS	Digital Cellular System

# Table of Contents

<b>1</b>	<b>Overview</b>	<b>1</b>
1.1	System Architecture	2
1.2	System Elements	3
1.2.1	VE Control Unit (VCU)	3
1.2.1.1	VCU Front Panel	4
1.2.1.2	VCU Rear Panel	6
1.2.2	VE Access Pod (VAP)	7
1.2.2.1	VAP Antenna Options	8
1.3	System Monitoring and Management	9
1.3.1	Integration with an External Fault Management System	9
<b>2</b>	<b>Installation Workflow</b>	<b>10</b>
<b>3</b>	<b>Infrastructure Requirements and Layout Planning</b>	<b>11</b>
3.1	General information on Location and Connections	11
3.2	Infrastructure Requirements	12
3.3	Coverage and Installation Planning	13
3.3.1	Types of Environments	13
3.3.1.1	Standard Environment	14
3.3.1.2	Open Environment	14
3.3.1.3	Dense Environment:	14
3.3.1.4	Combination of Environments	15
3.4	Planning VAP Layout	15
3.4.1	RF Coverage Factors	15
3.4.2	Mapping Locations	15
3.4.3	Optional Directional Antennas	16
3.4.4	Installation Plan Example	16
<b>4</b>	<b>VCU Unit Installation and Provisioning</b>	<b>18</b>
4.1	Installation of Master VCU	18
4.2	Auxiliary Connections	19
4.2.1	Alarm Output Connections	19
4.3	Installation of Slave VCU	21
4.3.1	Connections of VAP Ethernet Cables	22
4.3.2	Operation with LAN utilizing Power over Ethernet (PoE)	23

---

4.4	Provisioning the VE Control Unit.....	24
4.4.1	Configure the Computer IP Parameters.....	24
4.4.2	Provisioning the Master VCU Unit .....	25
4.4.3	Provisioning the Slave VCUs.....	32
<b>5</b>	<b>VAP Installation and Provisioning .....</b>	<b>34</b>
5.1	VAP Installation .....	34
5.1.1	VAP Kit Contents .....	34
5.1.2	VAP Locations and Mounting .....	35
5.1.2.1	Desk Mount .....	35
5.1.2.2	Wall Mount .....	36
5.2	Verifying Coverage.....	36
5.3	Naming the VAPs, Verifying Connections and Monitoring .....	37
<b>6</b>	<b>Navigating the Web Access Application .....</b>	<b>39</b>
6.1	Opening a Session and Authentication Levels .....	39
6.2	About the MobileAccessVE Web Access Window.....	40
6.3	Configuration Tab .....	41
6.3.1	Network Topology Tree .....	42
6.3.2	Configuration Display Area .....	43
6.4	Management Tab.....	44
<b>7</b>	<b>VCU Monitoring and Configuration.....</b>	<b>45</b>
7.1	Viewing VCU General Information .....	45
7.2	Viewing VCU Alarms.....	46
7.3	Master VCU RF Parameters.....	47
<b>8</b>	<b>VAP Monitoring and Configuration.....</b>	<b>48</b>
8.1	Viewing VAP General Information .....	48
8.2	Viewing VAP Alarms .....	49
8.3	VAP RF Parameters .....	50
<b>9</b>	<b>Administrative Operations.....</b>	<b>51</b>
9.1	Changing Password.....	51
9.2	IP Settings .....	52
9.3	SNMP Configuration Parameters .....	53
9.4	Upgrading (or Downgrading) VCU and VAP Software .....	54
9.4.1	Upgrading the VCU SW .....	55



9.4.2 Upgrading the VAP SW ..... 56

**10 Troubleshooting.....58**

10.1 Finding a Specific VAP in the Building ..... 58

10.2 Wireless Service is Not Available ..... 60

10.3 PoE is Not Working ..... 60

10.4 Ethernet Service is Degraded..... 61

10.5 No Service from Connected Access Pod ..... 61

10.6 VCU Cannot be monitored via SNMP ..... 63

**Appendix A - Traps .....64**

# 1 Overview

The MobileAccess**VE** Dual-Band solution provides enhanced, cost effective, in-building coverage for any small to large-sized enterprise environment. This solution is quickly and easily deployed using the existing Ethernet cabling infrastructure without affecting existing LAN services or performance.

The MobileAccess**VE** solution distributes two types of services to VE Access Pods (VAPs) installed throughout the enterprise: wireless services from the service provider's equipment and Ethernet services from the corporate LAN. Access Pods distribute the wireless services via integrated internal antennas (or optional external antennas), and provide Ethernet connectivity to LAN terminals. **VE** seamlessly coexists with the Enterprise LAN and does not consume LAN capacity.

The VAPs are distributed on each floor and plug into existing standard Ethernet jacks. They are powered via PoE technology and managed via a VE Control Unit (VCU) located in the floor's teleco closet. For site coverage that requires more than one VCU, several VCUs can be aggregated under a single Master VCU. The Master VCU provides the interface to the carrier's capacity sources and management.

This enhanced Dual-Band coverage solution can be quickly and easily installed with minimal disturbance to the enterprise. In less than a few hours and with no additional cables being required, a scalable and flexible solution is provided at a significantly lower total installation cost.

Currently, the VE Dual-Band system is available for the following band combinations:

- EGSM-UMTS
- CELL-PCS
- DCS-UMTS

The following figures illustrate *single-tier* and *multi-tier* VE installations.

In a single-tier installation the VCU is connected to both the service provider's equipment and the Ethernet switch, and distributes Ethernet and mobile services to up to 12 VAPs distributed over one more adjacent floors.

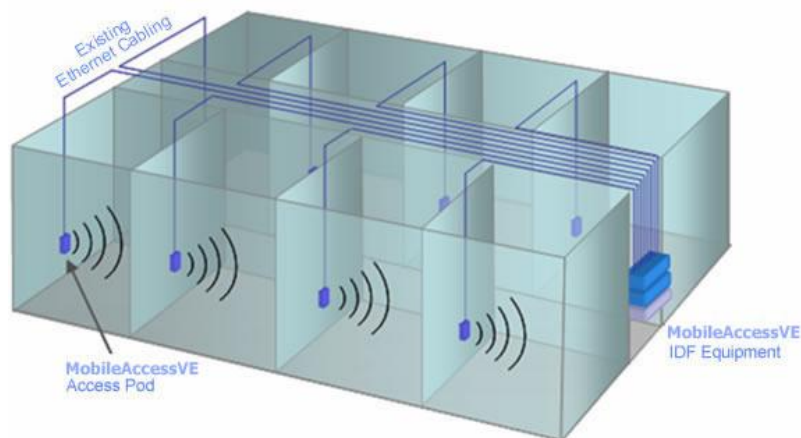

Figure 1-1. Single-Tier VE Installation

Multi-tier installation includes the Master VCU that supports up to 12 Slave VCUs. In this type of installation the provider's services are fed to the Master VCU through which the Slave VCUs are controlled and managed.

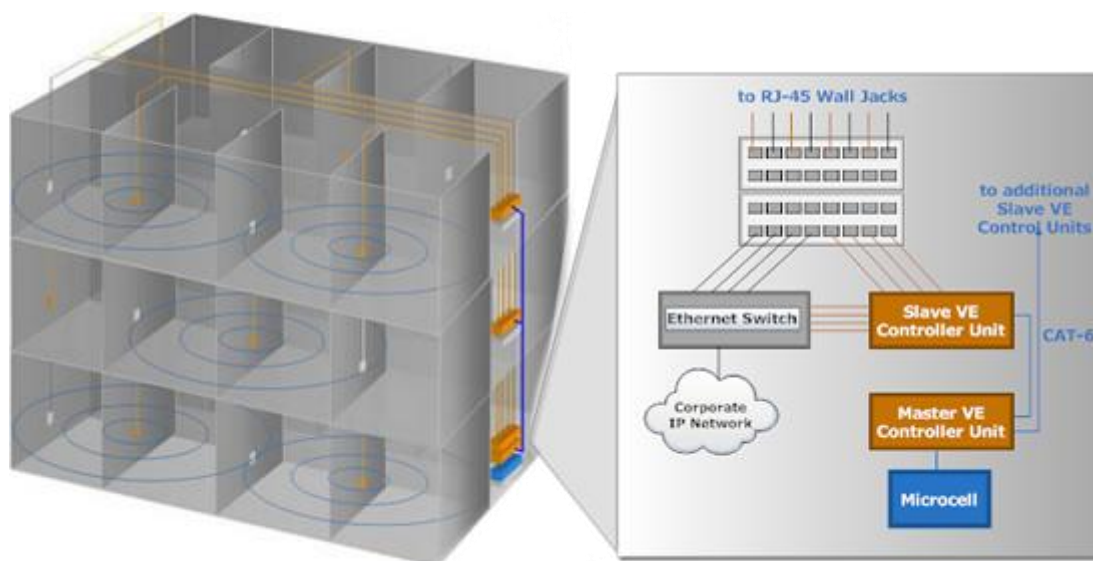

Figure 1-2. Multi-Tier VE Installation

## 1.1 System Architecture

**Main Elements** - The MobileAccessVE solution is based on the following main elements:

- **VE Control Unit (VCU)** – The control Unit can serve as either a Master or a Slave and interfaces the other VCUs (in case of Master) or the VAPs (when serving as Slave). The Master or Slave mode is automatically detected according to the VCU's physical connection. If a connection to another VCU is detected, the VCU will automatically be identified as a Slave; otherwise it will assume the role of a Master.
  - **Master VE Control Unit (Master VCU)** – installed in the main communication Telco closet, interfaces to the service provider's RF equipment, and provides secure, central management to up to twelve VCUs, as well as all connected VAPs. In cases where no Slave VCUs are required, VAPs can be connected directly to the Master VCU.
  - **Slave VE Control Unit (Slave VCU)** – installed in the telco/IDF closet and used to expand coverage to additional floors. Each VCU interfaces the Master VCU and up to twelve VAPs and twelve Ethernet connections.

The Slave VCUs distribute wireless service signals to each VAP along with PoE and (where relevant) Ethernet signals from the Ethernet switch, throughout the existing CAT-5e infrastructure.

The Slave VCUs are connected to the Master VCU using CAT-6 or 7 cables.

- **VE Access Pod (VAP)** – These are pluggable antennas distributed at strategic locations on the floor to provide maximum coverage. VAPs provide RF coverage via integrated, internal antennas. VAPs are also equipped with an interface for external antennas for special coverage requirements. VAPs are remotely powered from the VCU using Power over Ethernet (PoE). Local power is not required.

Up to twelve VAPs can be connected to a single VCU using LAN cables (CAT-5e or higher).

Note: When the total number of VAPs in the deployment exceeds 72, consult with MobileAccess support.

The following figure shows the Multi-tier Dual-Band VE solution architecture.

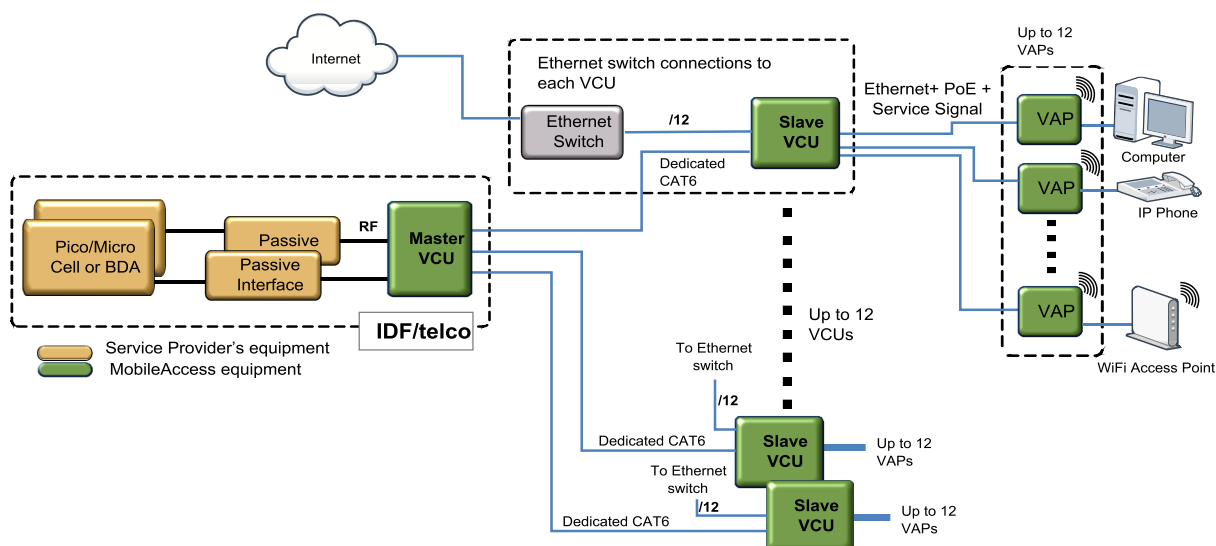

Figure 1-3. VE Multi-Tier Basic Architecture

The Master VCU distributes the wireless services from the service provider's equipment to the Slave VCUs. At the Slave VCUs, the wireless services are converged with Ethernet service and routed to the VAPs via the Ethernet LAN CAT-5e/6 cabling infrastructure.

The VAPs distribute the wireless services via integrated internal antennas or (optional) external antennas and provide Ethernet connectivity to the LAN terminals.

## 1.2 System Elements

This chapter describes the interfaces of the VE Control Units and Access Pods.

### 1.2.1 VE Control Unit (VCU)

#### Capabilities and interfaces

The VE Control Unit can operate as a Master VCU, managing up to twelve VCUs, or as a Slave VCU connected to up to twelve VAPs.

While operating as a Master VCU:

- Interfaces to RF source(s) and to VCUs
- Converges Wireless services and distribution to Slave VCUs
- Slave VCUs and VAP management and control
- Remote management of the entire deployment

While operating as a Slave VCU:

- Interfaces to Master VCU
- Converges Wireless services, Ethernet and PoE and interfaces to VAPs
- Management and control of connected VAPs

### 1.2.1.1 VCU Front Panel

The front panel supports the interfaces to the wireless services (two services – corresponding to the two supported bands) and includes interfaces to VAPs or Slave VCUs (depending on the configuration).

The front panel also interfaces to the Ethernet switch, includes a connector (VCU/VCH) for receiving the wireless services from the Master VCU (in Master/Slave configuration) and the management interface.

The following provides the front panel ports.

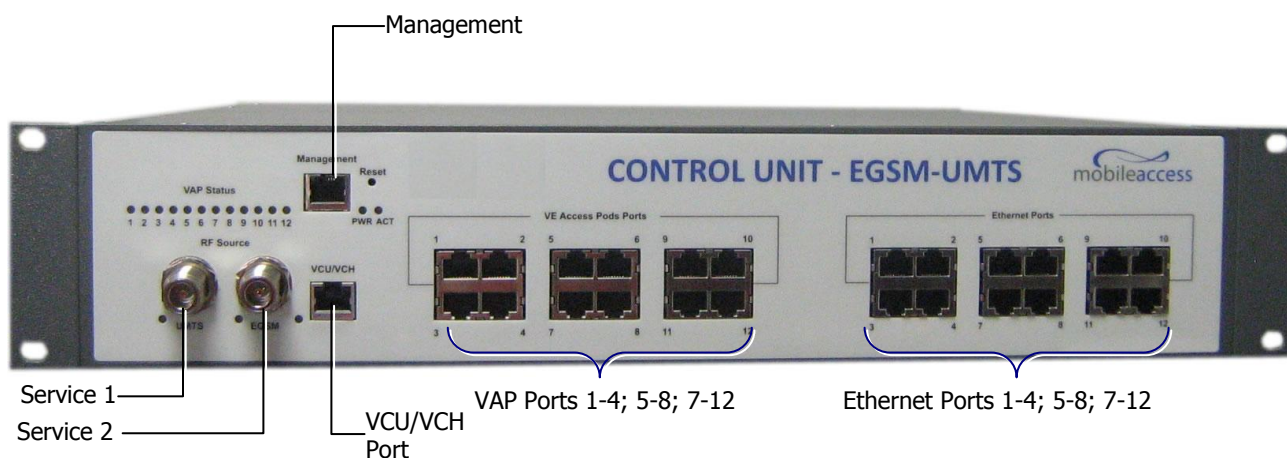

Figure 1-4. VCU Front Panel

Table 1: VCU Ports Description

Ports	Description
Service1 Service2	RF connections (two wireless services) to the service provider RF equipment (e.g. picocells). N-Type female connectors. Coax cables. <ul style="list-style-type: none"> <li>• EGSM-UMTS: Service 1 - UMTS, Service 2 - EGSM</li> <li>• CELL-PCS: Service 1 - PCS, Service 2 – CELL</li> <li>• DCS-UMTS: Service 1 – UMTS, Service 2 - DCS</li> </ul>
Management	RJ45 WEB management connection.
VE Access Pod Ports 1-4; 5-8; 7-12	VAP/VCU port connections. RJ-45 connection to VAP/VCU through the LAN infrastructure. CAT-5e/6 cables. If VCU is connected as Master – these are connections to the Slave VCUs. If VCU is connected as Slave – these are connections to VAPs.
Ethernet Ports 1-4; 5-8; 7-12	Ethernet port connections to Ethernet Switch. Ethernet cables (used only in Slave VCUs).
VCU/VCH	Used for connecting a Slave VCU to the Master VCU in a multi-tier deployment (connects to one of the VAP ports of the Master VCU).
Reset	N/A in current version.

The following provides a description of the front panel LEDs.

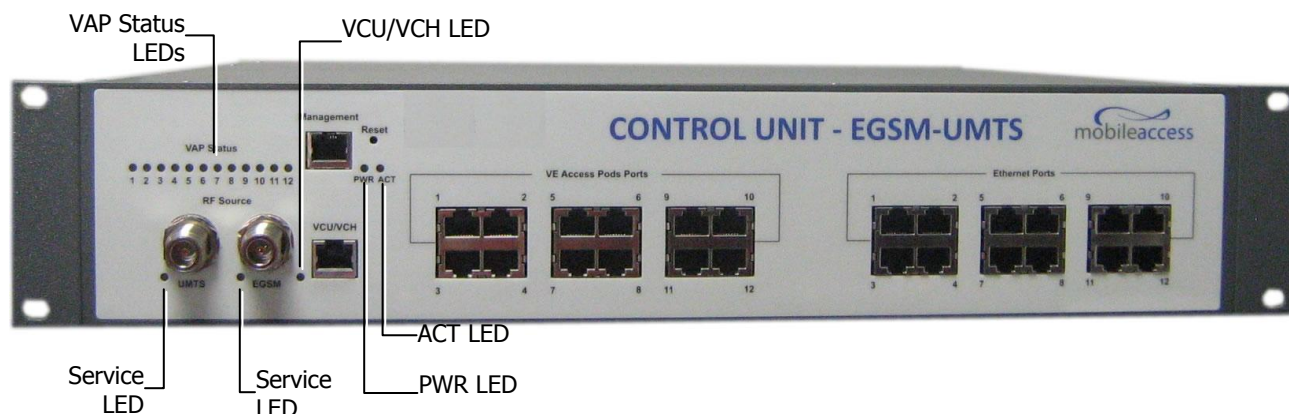

Table 2: VCU LEDs Description

LED	Description
PWR	Indicates whether the VCU receives power: Green - Power OK Disabled - No power received by VCU
ACT	VCU activity LED: Solid Green - During initialization Blinking Green - Normal system operation Fast Blinking Green - User activated <i>VCU Identify</i> on this VCU
VAP Status (One LED per port)	Indicates the status of the <i>corresponding</i> unit (VAP or VCU) Blinking Green - Unit is initializing Solid Green - Normal operation of unit Solid Orange - Unit is faulty, or unmanaged. This can be due to mismatch type, VoIP phone, etc. Fast Blinking Green - User invoked "Identify" command on the unit Off - No VAP or VCU connected to this port.
RF (One LED per Service)	Indicates the status of connected RF capacity source: Green - Master VCU only. Normal RF level Orange - Master VCU only. RF level is either too low, too high, or service has been turned off by the user. Off - VCU is Slave.
VCU/VCH	Indicates the status of the connection to the Master VCU: Off - Master mode (not connected to VCU) Blinking Green - During Attachment process with Master VCU Solid green - Slave (IF-IF) mode and connected to Master

### 1.2.1.2 VCU Rear Panel

The rear panel includes the following: power switch, AC input, AUX alarms, and service personnel connections.



Figure 1-5. VCU Rear Panel

Table 3: VCU Rear Panel Description

Connector	Description
Console	RS232 local connection for service personnel (D-Type 9)
Alarms	AUX alarms connections - see section 4.2
Power Input	Standard 3-pins AC power connector equipped with an ON/OFF switch. 90-264V AC, 47-63 Hz AC; 350W power consumption maximum.

## 1.2.2 VE Access Pod (VAP)

Each VAP provides the following functions:

- Antennas – distributes the wireless services signals. The antennas are internal, where external (optional) antennas can also be connected.
- Connection to Ethernet port – relevant when connected to jacks that provide an Ethernet connection to a user terminal.

The VAP can be mounted/hung on the wall or placed on a flat surface (such as a desk).

The following figure shows the desktop VAP.



Figure 1-6. VE Access Pod-Front

Table 4: VAP LEDs

LED	Description
Power	Solid Green - Power supplied to VAP Off - No power supplied to VAP
Activity	Off - No power supplied to VAP or Overall Status of VAP is faulty Blinking Blue - Power on, VAP is initializing (connecting to VCU) Solid Blue - Power on, unit operating normally Fast Blinking Blue - User invoked "Identify" command on corresponding VAP



The following figure shows the desktop VAP rear side and the underside view with the CAT-5e/6 patch-cord cable.

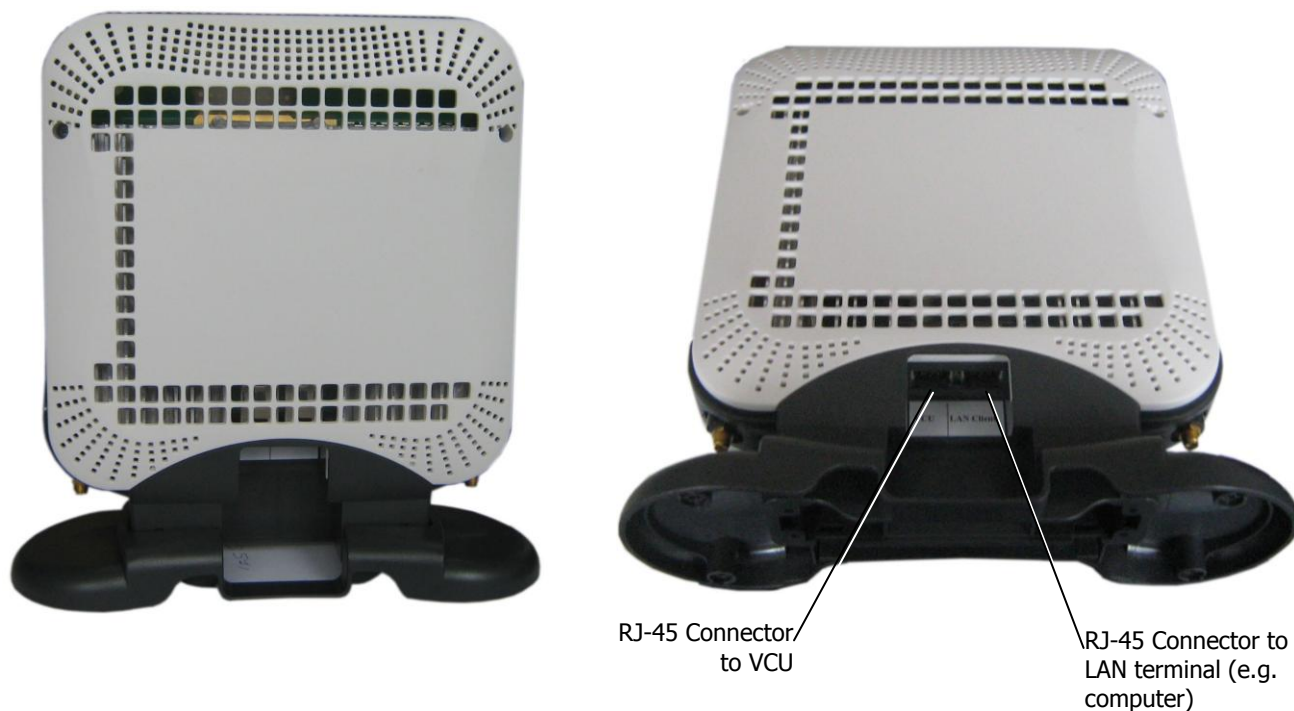

Figure 1-7. VE Access Pod-Rear

### 1.2.2.1 VAP Antenna Options

Two antenna options are available for VAPs:

- Integral internal antennas
- Connectors that interfaces to external antennas for special coverage requirements.

Note: By default, the VAP is set to transmit through the integrated internal antennas. To use the external antennas connectors, select the "External Antenna" option in VAP Config-Service RF tab of the VE Web GUI application (see 7.3).

## 1.3 System Monitoring and Management

The MobileAccess**VE** system (Master VCU, Slave VCUs, and VAPs) is centrally managed via a single Web connection to the Master VCU.

The basic screen in the GUI is the **Config** tab, which enables the user to view the system topology and setup parameters, Control Units, and all Access Pods connected to the Control Units.

Note: When locally connecting to a specific Slave VCU, only the VAPs connected to this VCU can be monitored. However, when connected to the Master, the entire deployment can be monitored.

The screenshot displays the MobileAccess VE GUI in the 'Config' tab. The interface includes a navigation menu on the left with options: Monitor, Config (selected), Events, Set-up, Management, and Help. A 'Log Out' button is located in the top right corner. The main area features a central image of a VCU hardware unit. Below this, there are two panels: 'VCU alarms & Mask' and 'Module Info:'. The 'VCU alarms & Mask' panel lists various alarms with checkboxes for masking, all of which are currently checked. The 'Module Info:' panel shows details for the 'Service1 RF' module, including Name (Master), Serial Number (55133455992), Product Revision (N/A), SW Active Version (3.16), and SW Inactive Version (N/A). It also includes a 'Reset' button and an 'Identity' dropdown menu set to 'OFF'. A date and time display shows 31/Mar/10 at 08:12:39.

### 1.3.1 Integration with an External Fault Management System

The MobileAccess**VE** system can be seamlessly integrated into any existing Fault Management (FM) system that supports SNMP events. The Master VCU generates a SNMP event for each relevant system alarm and forwards this trap to the pre-configured IP address of the external Fault Management system.

## 2 Installation Workflow

The following figure summarizes the main steps of the installation procedure:

### Installation Workflow

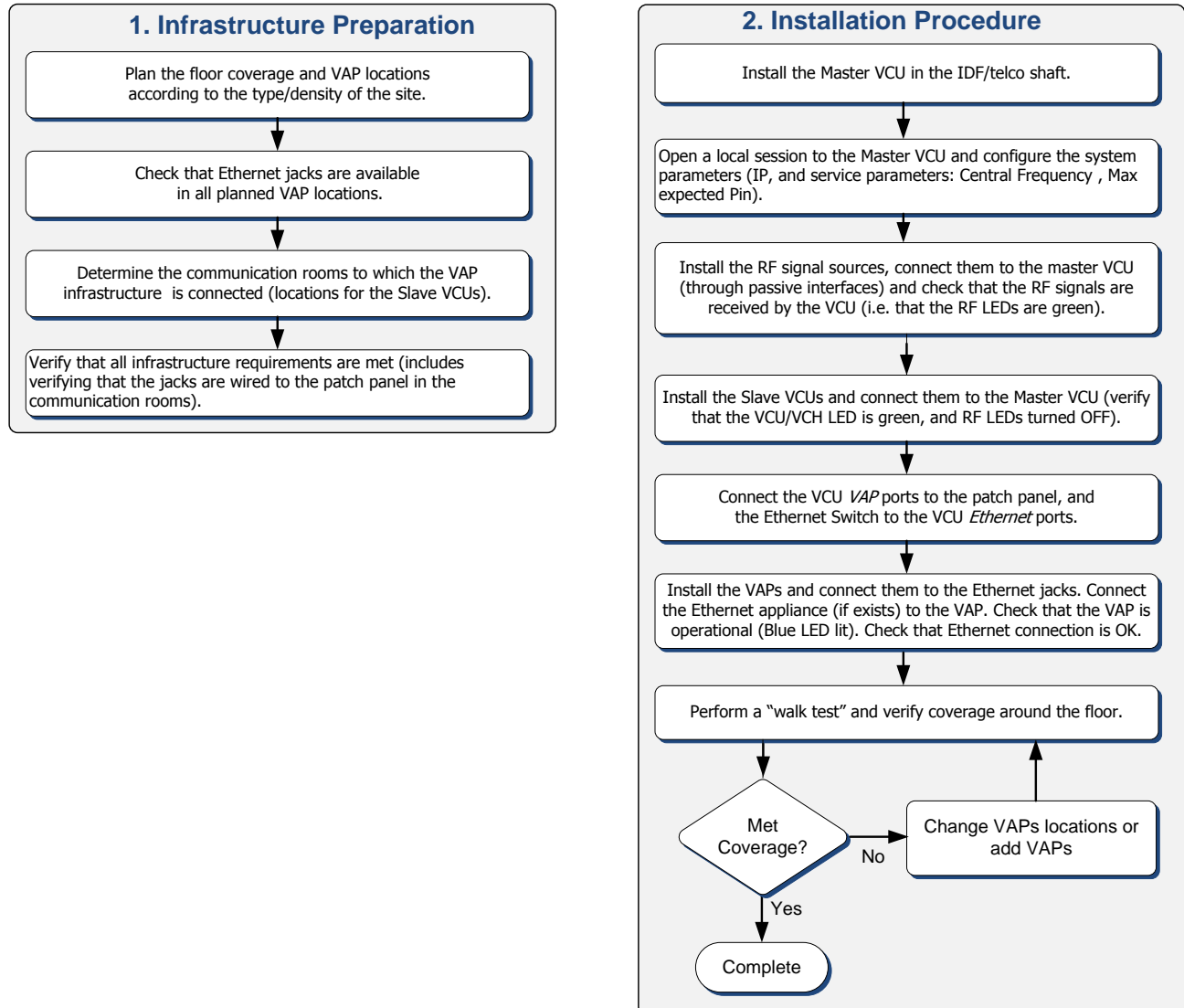

## 3 Infrastructure Requirements and Layout Planning

### 3.1 General information on Location and Connections

- **Service provider's RF equipment** - Macrocell, Microcell, Picocell, Femtocell, BDA, etc. connects to the VCU through a passive interface.
- **VCUs:**
  - **Master VCU** installed at the main IDF/telco cabinet and connected to all VCUs.
  - **Slave VCUs** installed at the IDF/telco cabinet of each covered floor and connected to the Master VCU, the Ethernet switch, and the VAPs through the cabling patch panel.
- **Wireless service signals from Master VCU to VCUs** – routed through dedicated Ethernet CAT-6/7 cabling.
- **Wireless service signals from VCUs to the VAPs** – routed through existing Ethernet CAT-5e/6 cabling infrastructure.
- **VAP location and mounting** – wall mounting or desk mounting. Connection to existing Ethernet jack (and external antenna if required).
- **VAP power source** - No power connections required. VAPs are power fed from VCU using PoE (Power over Ethernet) technology.

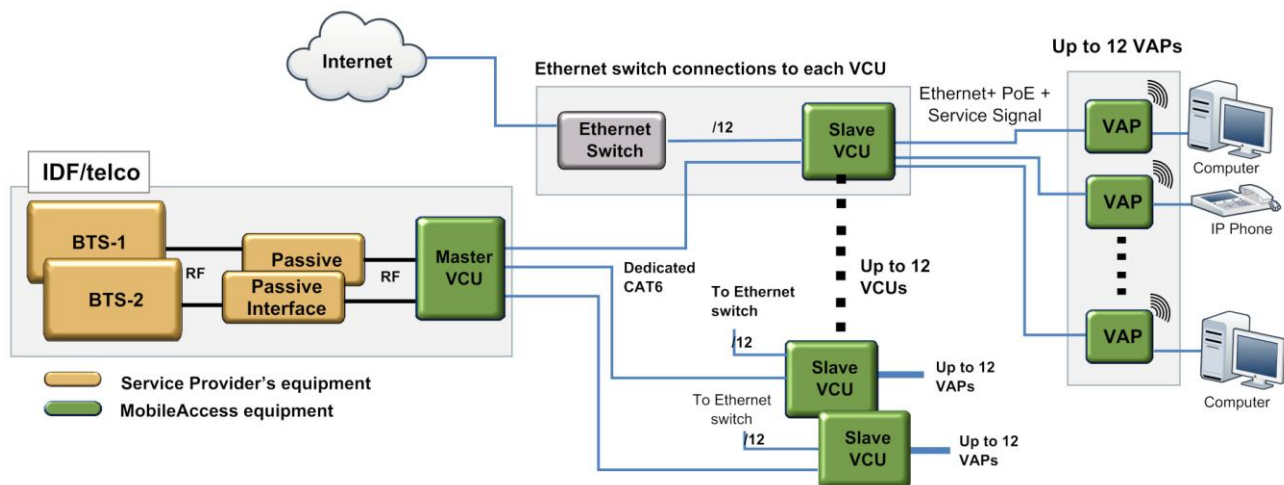

Figure 3-1. VE Multi-Tier Basic Architecture

## 3.2 Infrastructure Requirements

Ethernet standards specify that the maximum distance between an Ethernet switch and an appliance (computer, WLAN AP etc) should not exceed 100m (300ft). Therefore, when VE shares the IT LAN, the maximum distance for a given cable run cannot be longer than 100m (300ft) between the Ethernet switch and appliance, including all patch cords (from switch to VCU, from VCU to patch panel, from RJ-45 outlet to VAP, and from VAP to appliance).

Typically the horizontal cabling system will be connected to patch-panels in the communication rooms. The entire cabling system, including the patch panels and patch cords, should adhere to the CAT-5e/6 standard. Specifically all pairs of the CAT-5e cable should be wired in the patch panels (and patch cords).

1. IDF/Telco closet space for one or more VCUs depending on the number and locations of the installed VCUs: (48.3cm x 51.3cm x 8.88cm) per VCU.

---

Note: When planning the IDF/telco shaft, take the RF equipment (picocell/microcell or BDA) and the VCU into consideration.

---

2. 350 Watts of AC power to the VCU IDF/Telco closet.
3. Building infrastructure:
  - CAT-5e/6 cabling, Shielded Twisted Pair (STP)
  - 24 AWG minimum diameter for CAT-5e cabling
  - Dedicated CAT-6/7 STP cable from Master VCU to Slave VCUs with run lengths NOT exceeding 100m (300ft) and no shorter than 10m (33ft).
  - CAT-5e/6 STP cable from VCU to each VAP with run lengths NOT exceeding 100m (300ft) and no shorter than 10m (33ft). VAPs can be connected over existing CAT-5e/6 cabling infrastructure and existing Ethernet jacks without affecting the LAN.

---

Note: Verify with the IT department that the existing cables can support the VE installation. If available, review the infrastructure documentation to determine cable types and lengths. If the infrastructure documentation is not available, attempt to visually identify the cable type. Depending on the cable vendor, the cable type may be listed on the cable sheath. It is recommended to use a Fluke cable tester to measure the cable length of the most remote VAPs.

---

4. Master VCU Cable Connections:
  - 2 x N-type female, 50 ohm interfaces to carrier equipment
  - Up to 12 x RJ-45 interfaces to Slave VCUs
  - 1 x RJ-45 interface to Management
  - 1 x D-Type 9 pins RS-232 interface for local craft
  - 1 x D-Type 15 pins interface for External Alarms (dry contacts)
5. Slave VCU Cable Connections
  - 1 x RJ-45 interface to Master VCU (not used in small single-tier deployments)
  - 12 x RJ-45 interfaces to VAPs
  - 12 x RJ-45 interfaces to Ethernet Switch for LAN service
  - 1 x D-Type 9 pins RS-232 interface for local craft

## 3.3 Coverage and Installation Planning

---

Note: The following section provides information required for planning the VAP installation on a single floor. In a multi-tier installation, this procedure is performed for each individual floor.

---

The maximal coverage area of each VAP is affected by the density and type of environment being covered. Therefore, it is recommended to determine the location in two phases:

- Plan the *ideal* location of each VAP in order to achieve complete coverage of the floor.
- Select the *exact* location according to the location feasibility, where each VAP unit may be wall or desk mounted and an option for an external antenna is available.

The supplied services (wireless only or Ethernet and wireless) depend on the jack to which the VAP is connected:

- If the jack supports an active Ethernet connection, the VAP will distribute LAN traffic along with the wireless service. For more information see section 4.3.1.
- If the jack is not currently active (not connected to an Ethernet switch), the VAP will distribute only the wireless services.

This section provides information on coverage criteria in various types of environments (Open, Standard, Dense and Merged) and provides rules-of-thumb for various installations of the VAPs.

---

Note: Section 3.4 provides a detailed example of installation planning in various types of environment. It is recommended to review this example after reading this section.

---

### 3.3.1 Types of Environments

This section describes the different types of installation environments and provides guidelines for best coverage of each type of space.

The coverage guidelines in this section are conservative “rule of thumb” estimates of RF coverage per VAP, meant to be used in scenarios in which detailed designs are not performed. When the coverage layout is designed, the coverage per VAP is expected to increase by up to 33%. Coverage estimates in this section assume 25% overlap between the coverage areas of neighboring VAPs to ensure robust, full coverage throughout the enterprise with no “dead zones”.

The coverage guidelines in the following tables are provided for the *higher* frequency bands (UMTS & PCS). The lower frequency bands (DCS, EGSM & CELL) are omitted from the tables since coverage in these bands will be better than that of the higher frequency bands. The coverage of a dual-band system will be determined by the higher frequency band (i.e. PCS for CELL/PCS and UMTS for EGSM/UMTS and DCS/UMTS).

### 3.3.1.1 Standard Environment

A traditional office environment with offices, hallways and scattered cubicles.

Table 5: Standard Environment Installation Distances

Band	PCS	PCS	UMTS
Technology	CDMA or GSM	WCDMA	WCDMA
Downlink Frequency	1900 MHz	1900 MHz	2100 MHz
Signal Propagation from VAP	67 feet (20.5 m)	64 feet (19.5 m)	57.5 feet (17.5 m)
Recommend spacing between VAPs	134 feet (41 m)	128 feet (39 m)	115 feet (35 m)
Recommended maximum distance of VAPs from outer walls	67 feet (20.5 m)	64 feet (19.5 m)	57.5 feet (17.5 m)
Coverage Area per VAP	14,250 sqft (1,324 sqm)	12,750 sqft (1,185 sqm)	10,425 sqft (969 sqm)

### 3.3.1.2 Open Environment

An environment with minimal obstacles (e.g. walls). This type of space can be a large conference or meeting room, cubical areas, lobby, or atrium.

Table 6: Open Environment Installation Distances

Band	PCS	PCS	UMTS
Technology	CDMA or GSM	WCDMA	WCDMA
Downlink Frequency	1900 MHz	1900 MHz	2100 MHz
Signal Propagation from VAP	90 feet (27 m)	82.5 feet (25 m)	67 feet (20.5 m)
Recommend spacing between VAPs	180 feet (55 m)	165 feet (50 m)	134 feet (41 m)
Recommended maximum distance of VAPs from outer walls	90 feet (27.5 m)	83 feet (25 m)	67 feet (20.5 m)
Coverage Area per VAP	25,425 sqft (2,362 sqm)	21,350 sqft (1,983.5 sqm)	14,250 sqft (1,324 sqm)

### 3.3.1.3 Dense Environment:

A dense environment consists of a relatively large amount of walls, offices, equipment, tall file cabinets, bookshelves, and other items that could potentially impact the wireless signal.

Examples include dense offices, hospitals, and manufacturing spaces.

Table 7: Dense Environment Installation Distances

Band	PCS	PCS	UMTS
Technology	CDMA or GSM	WCDMA	WCDMA
Downlink Frequency	1900 MHz	1900 MHz	2100 MHz
Signal Propagation from VAP	64 feet (19.5 m)	60 feet (18 m)	45 feet (13.5 m)
Recommend spacing between VAPs	128 feet (39 m)	120 feet (36 m)	90 feet (27.5 m)
Recommended maximum distance of VAPs from outer walls	64 feet (19.5 m)	60 feet (18 m)	45 feet (13.5 m)
Coverage Area per VAP	12,750 sqft (1,185 sqm)	11,250 sqft (1,045 sqm)	6,300 sqft (585 sqm)

### 3.3.1.4 **Combination of Environments**

In areas with a combination of environments, place VAPs on the border between the different environment types slightly closer to the denser area.

For example, in a cubical area with the outside wall having offices, simply locate the VAPs a little *closer to the outside offices* to provide coverage through the office walls. (See VAPs 11 and 13 in the floor plan map in section 3.4.3.). To ensure maximal coverage, VAPs can be re-located or added. If a coverage gap is detected, the VAPs can be re-located until coverage gaps are filled.

## 3.4 Planning VAP Layout

The following section describes the steps of planning VAPs along the covered floor. At the end of this section an example of a planning map is provided.

---

**Note:** It is highly recommended to use a floor plan when planning the VAPs locations.

---

### 3.4.1 RF Coverage Factors

It is important to note the type of factors that can severely impact RF coverage, and should be avoided:

- **Metallic Structures** such as elevators, high file cabinets, and some moveable metallic partitions severely degrade RF signals. All efforts should be made to locate VAPs in front of, or above metallic objects (desks, filing cabinets) to allow the signal to propagate.
- **Wall Materials** such as concrete, tile, and cinderblock, as well as bathroom fixtures typically have fairly high signal attenuation and should be considered as dense spaces.
- **Types of Glass** that have metallic coatings can affect RF coverage, typically exterior or mirrored. However this issue is not normally encountered inside a building.

### 3.4.2 Mapping Locations

#### To map the VAP Locations

1. Map out the available Ethernet jack locations and mark all CAT-5e/6 drop locations on the floor plan map.

---

**TIP:** The size and number of the ceiling tiles can be used to measure distances.

---

2. Using the floor plan and the VAPs coverage guidelines (as given in section 3.4.3), mark approximately where you would like to place each VAP in the facility.  
VAPs may be added (or removed) at anytime for optimal coverage.
3. For each jack being used to connect a VAP, check if the jack is already connected to the Ethernet switch. .
4. Connect the Ethernet cables corresponding to the selected jacks according to section 4.3.1.
5. It is also recommended to check the area where each VAP will be installed to ensure the installation is feasible.



### 3.4.3 Optional Directional Antennas

Each VAP has an integrated internal antenna that provides isotropic radiation. To prevent interference and improve coverage, connect directional antennas to VAPs installed near outer walls. The VAP antenna parameter must be set accordingly via the Web GUI – see 8.3.

### 3.4.4 Installation Plan Example

The Following figure shows a floor plan map with all required marks:

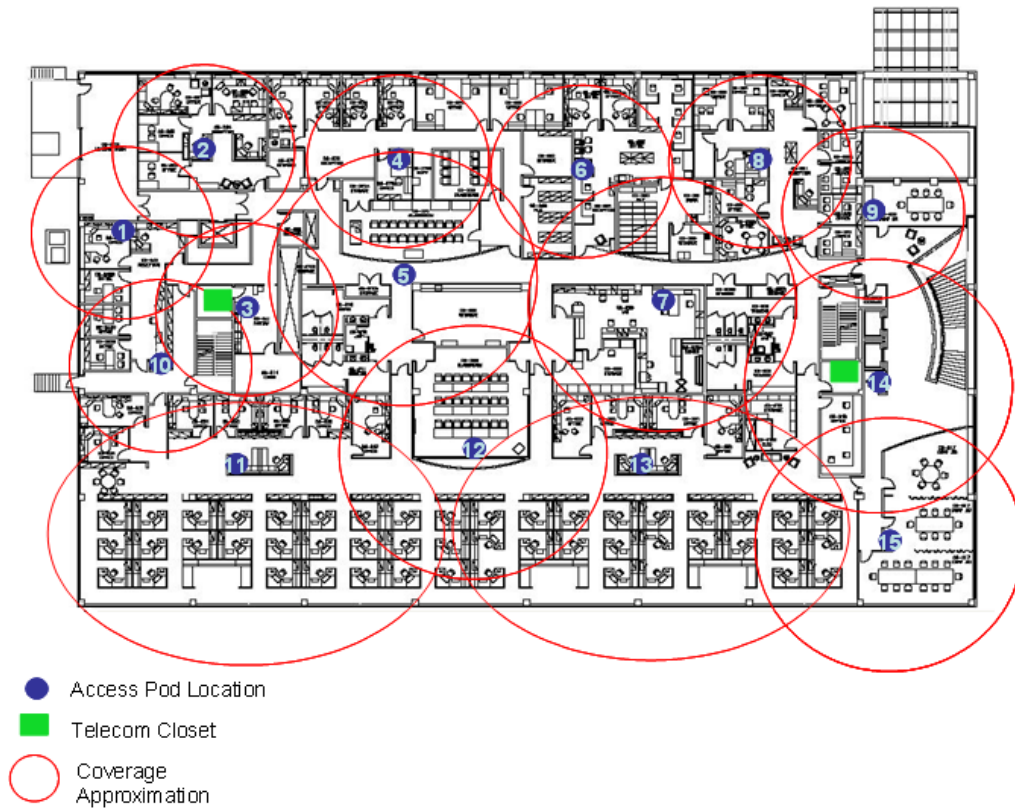

Figure 3-2. Floor Plan Example

**Notes:**

- The red VAP coverage circles have an approximate radius of 45, 60 and 70 foot (14, 18 and 21 meters) for the small, medium and large circles respectively. Diagram is drawn according to the guidelines for UMTS service, given in section 3.3.1.
- VAP 3 is surrounded by the bathroom and stairwell which are considered dense objects and would reduce coverage in that area by the other VAPs.
- VAP 5 is an example of a unit that provides good coverage down the hallways in an Open Environment.
- VAPs 11 and 13 are placed closer to the offices to provide better coverage to them, but on the open side will actually cover a much greater area. This is why the coverage is larger and shown here more as an oval than a circle.
- The area between VAPs 7 and 14 would probably be the lowest coverage spot in the building because of the bathrooms and stairwell on either side. If after the system is installed, this area is still a little low on coverage, a VAP can be added, but it may also be covered by VAP 14.

---

Note: The plan can be modified at any time by moving the units around or by adding units.

---

The following figure depicts an actual measured quantified coverage of a floor area planned according to the above rules.

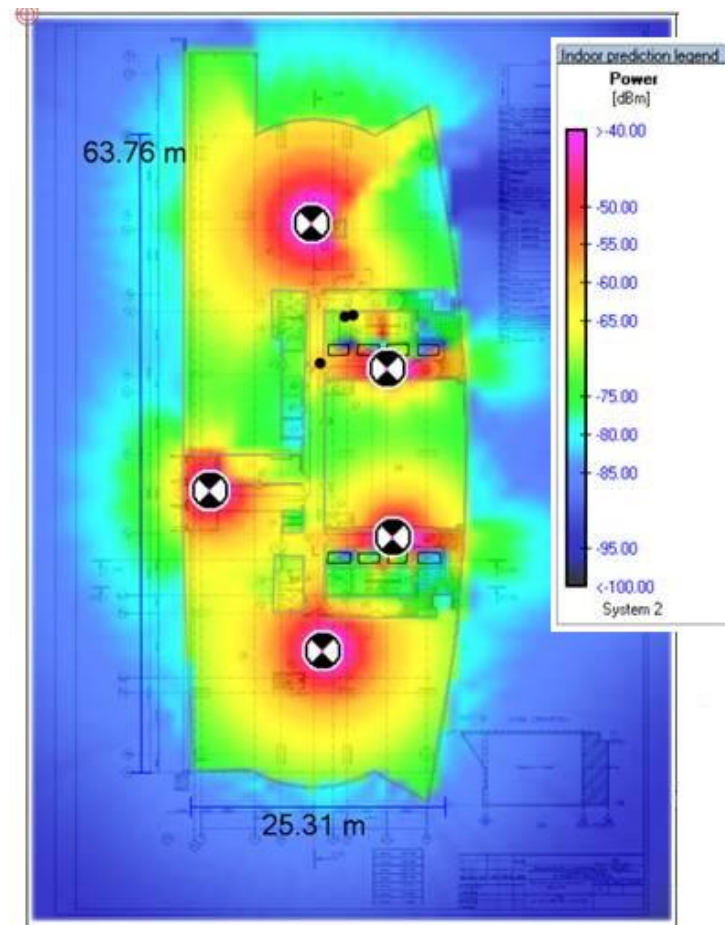







Figure 3-3. Distributed VAPs propagation, 12dBm output power @ 1.8 GHz

## 4 VCU Unit Installation and Provisioning

This section describes the installation and configuration procedures for VE Control Units (VCU) located on each floor. These should be performed only after planning the floor coverage and installation locations, as described in the previous sections.

The VE VCU Kit includes:

*Table 8: VCU Kit*

Description	Unit
Dual-Band VE Control Unit (VCU) Kit	
Power Cord	
VE SW CD	
Local Configuration Cable (crossed RJ-45 cable)	
Brackets for securing the VCU to a 19" rack (shipped assembled to the VCU)	

### 4.1 Installation of Master VCU

The VE Control Unit can be installed as a Master VCU and control up to (12) Slave VCUs and is installed in the main IDF/telco closet. This section describes the Master VCU installation procedures.

1. Install the **Master VCU** in the main Telco closet. The Master VCU can be installed in a rack, placed on a shelf, or secured using the supplied bracket.
2. Apply power to the Master VCU and verify that the **PWR** LED is lit. Also verify that the unit ACT LED completes initialization (blinking light) and shows a solid green light.
3. Connect (or request the service provider's service personnel to connect) the provider's **signal source** (Macrocell, Microcell, Picocell, or BDA etc.) to the **Master VCU front panel RF ports** (through passive interface). Power on the signal sources.

Note: The RF Source LED (see following figure) of the connected port on the Master VCU should be lit GREEN, indicating that the Master VCU senses the RF signal from the source at the expected level (according to Max Expected Pin). After connecting the capacity source, if the LED remains RED verify that the Max Expected Pin is configured properly and service is enabled.

4. Connect the **Master VCU VAP ports** to the **Slave VCUs VCU/VCH** ports via the patch-panel that feeds the dedicated CAT-6/7 cabling system.

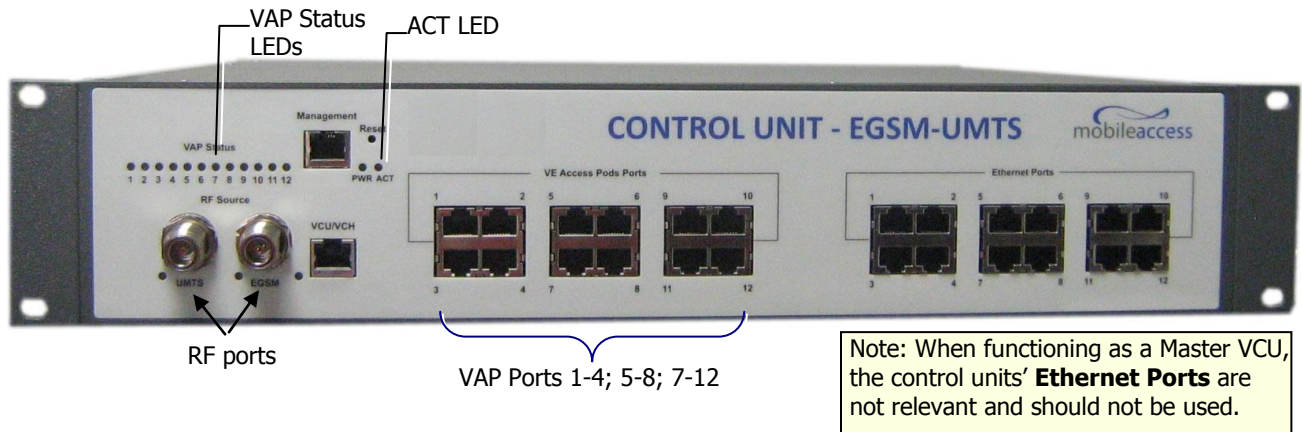

NOTE: After the Slave VCUs are connected (according to section 4 ), verify that that the Master VCU **VAP Status** LEDs which correspond to the connected Slave VCUs complete initialization (blinking light) and show a solid green light.

## 4.2 Auxiliary Connections

The auxiliary connections are performed through the Master VCU rear panel **Alarms** port. See following figure.

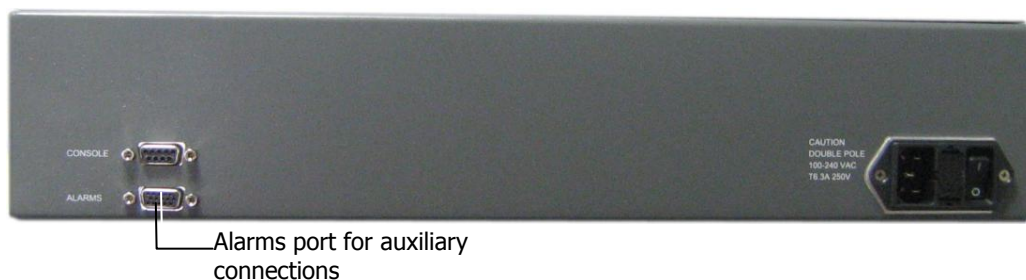

### 4.2.1 Alarm Output Connections

The controller can provide Major and Minor Output Alarms. These alarms can be connected directly to either the auxiliary input of the Base Station or to any additional dry-contact application.

A Major Alarm is generated when there is an alarm condition in one or more VCUs, while a Minor Alarm is generated when there is an alarm condition in one or more of the VAPs.

Note: If only one alarm is required (Minor or Major) an external connection of a wire jumper between pins 8 and 13 is necessary (normally closed).

Connect the relevant alarms according to the connector pinout below.

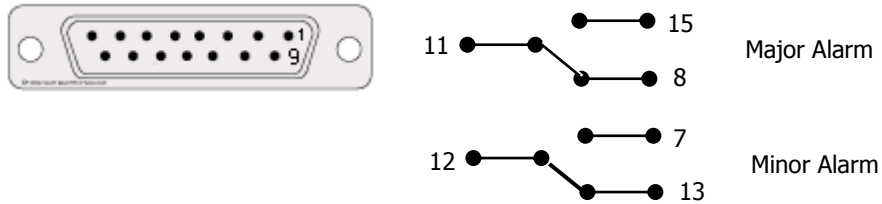

Table 9. Alarms Connector – used pins

8 – Major Error Signal (normally closed)	7 – Minor Error Signal (normally open)
11 – Major COM	12 – Minor COM
15 – Major Error Signal (normally open)	13 – Minor Error Signal (normally closed)

### 4.3 Installation of Slave VCU

1. Install the Slave VE Control Unit (VCU) in the Telco closet corresponding to the floor being covered. The Slave VCU can be installed in the rack using the supplied bracket in the IDF closet. Apply power to the Slave VCUs and note that the VCU **PWR** LED is lit. Note that the unit ACT LED completes initialization (solid light) and shows a blinking green light. See Figure 4-1.

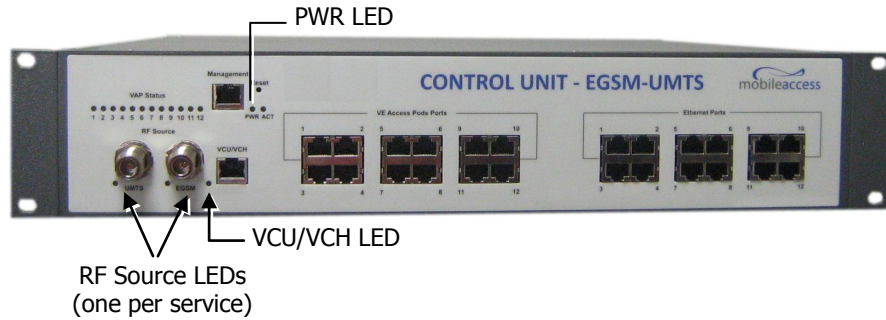
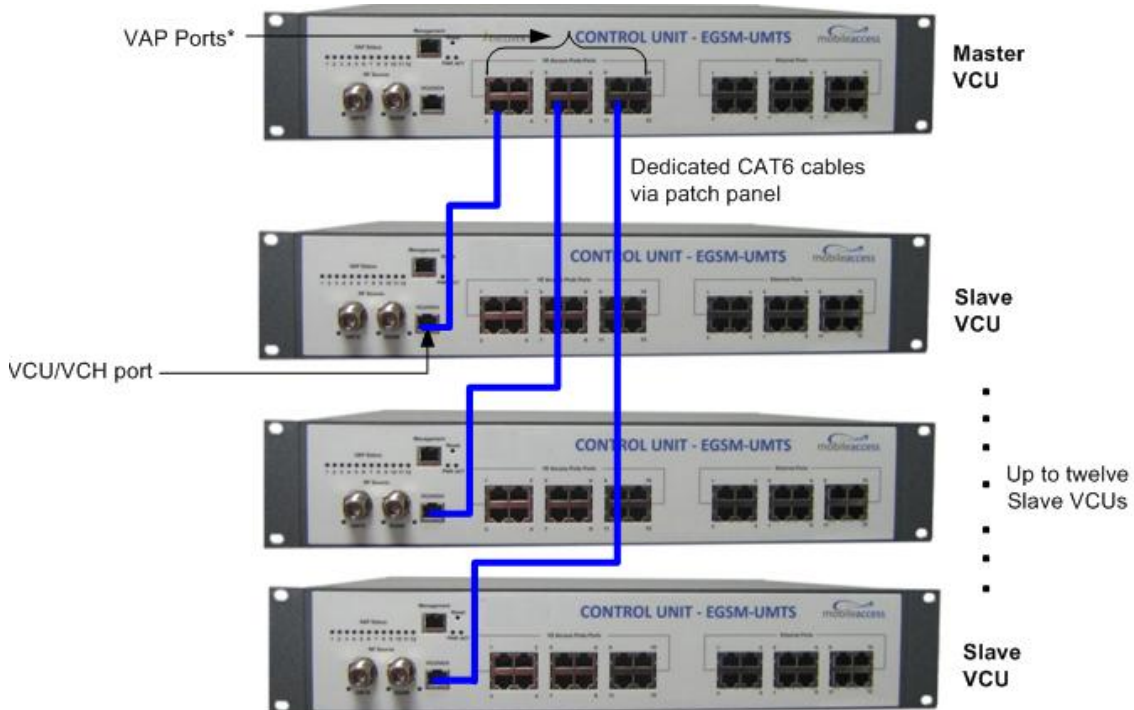

Figure 4-1. VCU PWR, RF and VCU/VCH LEDs

2. Connect the Slave VCU front panel **VCU/VCH** port to the Master VCU **VAP** port via the patch panel using dedicated CAT6 cables. Verify that the VCU/VCH LED completes initialization (blinking light) and shows a solid green light. The RF LEDs (of both services) should turn OFF.



\* When control unit functions as Master VCU the VCU VAP ports serve as Slave VCU connection ports

Figure 4-2. Master and Slave VCU Connections

3. Connect the Slave VCU **VAP** ports to the patch-panel that feeds the existing structured CAT-5e/6 cabling system.
4. According to VAPs layout plan (as explained in section 3.4.2) connect the Ethernet switch cables (see section 4.3.1 for more detailed explanation).
  - If the requested jack is already in use, disconnect it from the Ethernet switch and reconnect it to the corresponding **Ethernet** port in the Slave VCU front panel.

### 4.3.1 Connections of VAP Ethernet Cables

For VAPs installed on currently ACTIVE Ethernet ports, shift the relevant Ethernet LAN connections as follows.

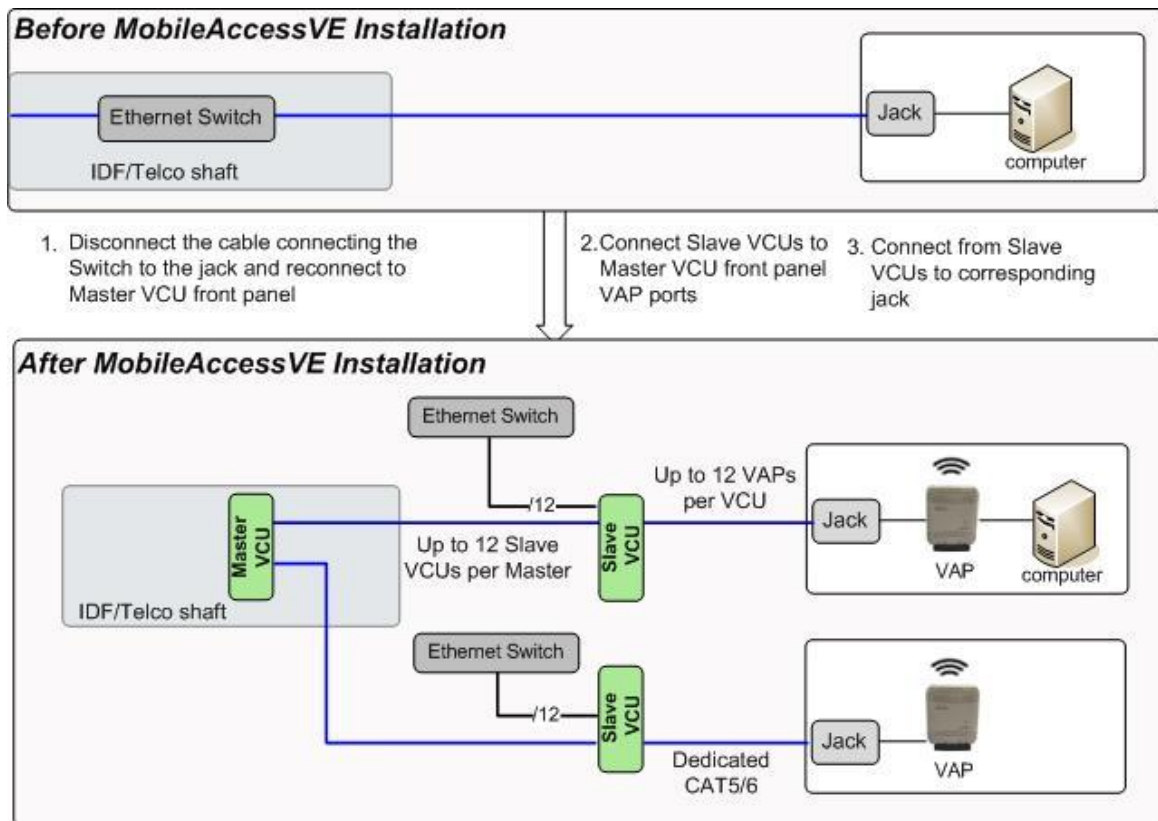

For VAPs installed on currently INACTIVE Ethernet ports, connect as follows.

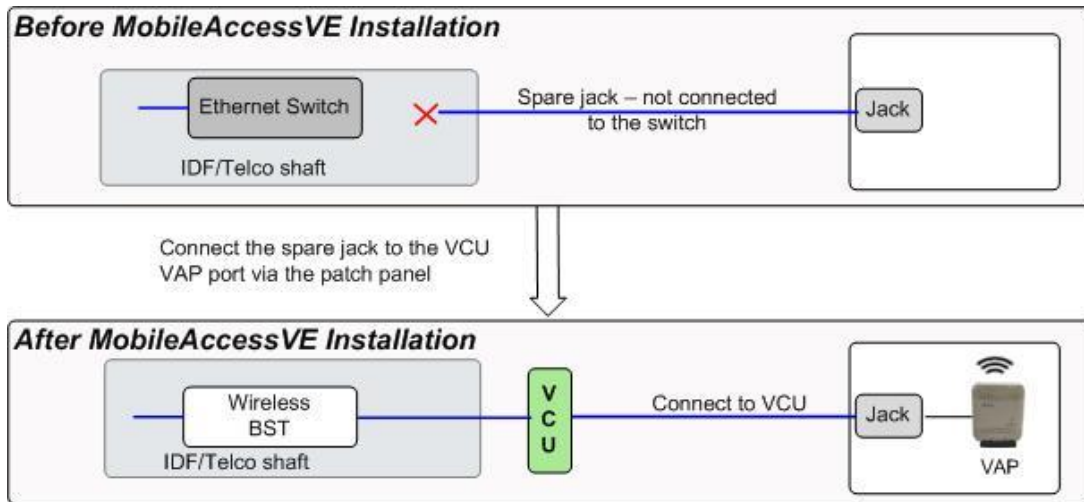

NOTE: After the Slave VCUs are installed and connected to the correct ports in the patch panels, please proceed with the VAP installation as described in chapter 5 . However, it is recommended to complete the VCU provisioning first (see section 4.3.2) because when installing the VAPs they will instantly provide the wireless service (and the installer will be able to check the coverage).

### 4.3.2 Operation with LAN utilizing Power over Ethernet (PoE)

Power over Ethernet (PoE) is a technology that enables passing electrical power over the Ethernet cabling. Power can either come from a PoE-enabled Ethernet device (e.g. switch) or from a "mid-span" device built specifically for "injecting" power into the Ethernet cabling.

PoE can operate over two different pairs in a CAT-5e/6 cable. These two methods are referred to as "alternative a" and "alternative b". All PoE compatible appliances, such as WLAN APs and IP Phones, support both alternatives and automatically detect and use the power on the appropriate pairs (alternative a or b).

MobileAccessVE supports sharing LAN infrastructures that use either 802.3af PoE or 802.3at PoE.

In the current release MobileAccessVE supports operation with **"alternative a" PoE**.

Note: Future enhancements will support coexistence with "alternative b" PoE. If this is currently required, consult MobileAccess.



## 4.4 Provisioning the VE Control Unit

This chapter describes how to set the basic parameters required for operation and remote management of the Master VCU using the Web GUI. The configuration dialogs are fully described in Chapter 6 .

The Master or Slave mode is automatically detected according to the VCU's physical connection. If a connection to another VCU is detected, the VCU will be identified as a Slave, otherwise it will assume the role of a Master.

---

### Notes:

1. The initial configuration of the Master VCU is performed via local connection using a cross-cable and connecting to VCUs default IP address. After performing the initial configuration and assigning the Master VCU an IP address, the system can be connected, monitored, and configured via a remote management connection.
  2. The configuration and management of all of the system units (VCUs and VAPs) is performed via local or remote connection to the Master VCU unit.
- 

### 4.4.1 Configure the Computer IP Parameters

Configure the computer local LAN connection to operate in the same subnet as the default VCU IP address. Note that the procedure may vary slightly depending on the operating system installed on your computer. The following procedure is for Windows XP.

#### To configure the computer's IP parameters:

1. Click the **Start** menu and choose **Control Panel**.
2. In the **Control Panel**, click **Network and Internet Connections**.
3. Click **Network Connections** and then double-click **Local Area Connection**.

The Local Area Connections Properties dialog box appears with the General tab displayed by default.

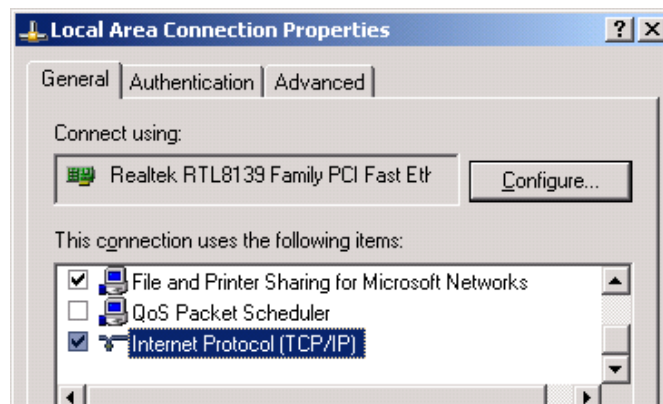

4. In the Items list, select "Internet Protocol (TCP\*IP)" and click the Properties button.
5. The "Internet Protocol (TCP/IP) Properties" dialog appears.

NOTE: The Master VCU is supplied with the default IP address 192.168.1.1.

- In order to communicate with the unit, it is necessary to assign your computer a *Static IP* address in the same subnet: 192.168.1.2 to 192.168.1.250.  
(i.e. 192.168.1.9 as shown in the example).
- Define the subnet mask as shown: 255.255.255.0

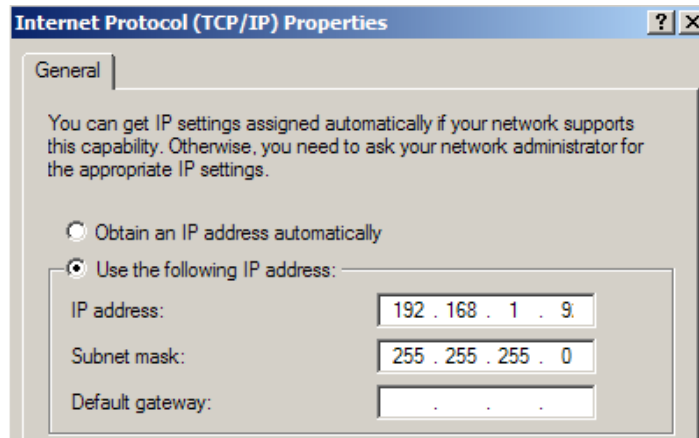

6. Click **OK**.
7. The computer communication parameters are now defined and you can open a session to the Master VCU and provision the unit.

#### 4.4.2 Provisioning the Master VCU Unit

1. Perform a local connection to the Master VCU unit by connecting the Master VCU front panel **Management** port and a laptop computer.

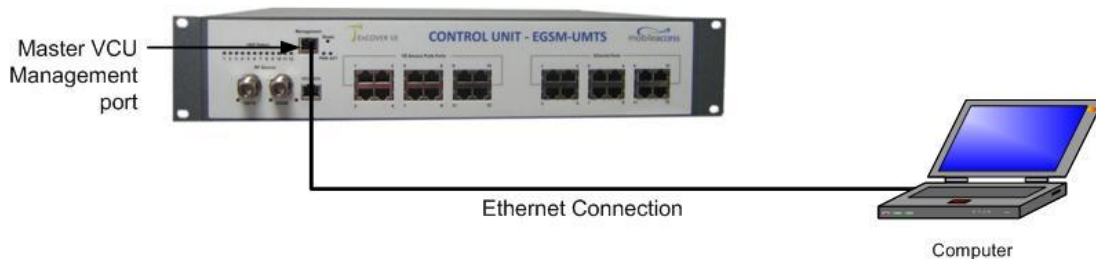

2. Open a web browser and type the Master VCU IP address in the address bar (Default: 192.168.1.1).



The Login window appears.



3. Type the **User Name "engineer"** and enter the **Password "eng"**.

The MobileAccessVE Web GUI appears.



4. Choose the **Management** tab in the main menu bar and click the **IP Settings** tab on the side bar.

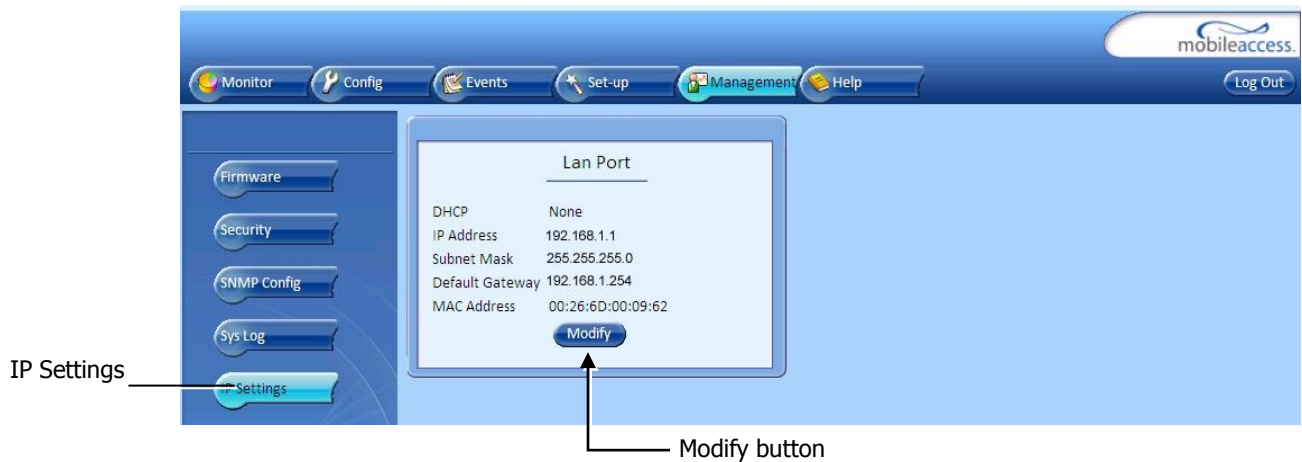

---

Note: See section 6.4 for a description of the Management tab.

---

5. Click the **Modify** button to define the STATIC **IP Address** according to existing LAN.

---

Note: After the initial IP configuration, the Master VCU can be accessed remotely via Ethernet.

---



- Set the Static IP address parameter (DHCP is not currently available)  
Default definitions:
    - The Default IP Address : 192.168.1.1
    - The Default Subnet Mask: 255.255.255.0
    - The Default Gateway: 192.168.1.254
  - Click **OK**.
6. Log out and then log in again with the new IP settings.
  7. Select the **Config** tab in the main menu bar.

---

Note: See section 6.3 for a complete description of the **Config** tab.

---

8. The Master VCU appears in the Network Topology Tree as **VCU-M**. Select the Master VCU by clicking on it.

The screenshot shows the MobileAccess VE configuration interface. On the left, the Network Topology Tree lists various components, with 'VCU-M-Master' highlighted. The main area displays a VCU unit image. Below the image, there are three tabs: 'Module Info', 'Service1 RF', and 'Service2 RF'. The 'Module Info' tab is selected and circled in red. It contains the following information:

Field	Value	Action
Name	Master	Modify
Serial Number	55133455992	
Product Revision	N/A	
SW Active Version	3.16	
SW Inactive Version	N/A	
Reset		Reset
Identity	OFF	

On the left side of the configuration panel, there is a 'VCU alarms & Mask' section with a list of alarms and checkboxes for masking them. The overall status is shown as green.

9. Before configuring the Master VCU it is recommended to give the unit an indicative name. To assign the Master VCU an indicative name:

- Select the **Module Info Tab** and click the **Modify** button.

This close-up shows the 'Module Info' configuration panel. The 'Name' field is empty, and the 'Modify' button is highlighted with an arrow pointing to it from the text 'Click Modify'. The other fields and buttons are as follows:

Field	Value	Action
Name		Modify
Serial Number	07425C3	
Product Revision	N/A	
SW Active Version	0.2	
SW Inactive Version	N/A	
Reset		Restart
Identity	OFF	

- Type the unit name (up to 17 alpha-numeric characters) in the **Controller Name** dialog and click **OK**.

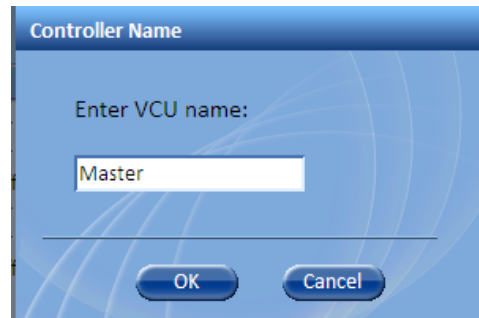

- Set the RF parameters for each connected service (up to two). Each service (Service1/Service2) is configured through its' corresponding tab. To configure the service RF parameters:

- Select the Service RF tab (Service1 RF/Service2 RF) of the service being configured.

- Click **Modify** and enter the DL central frequency for each service according to the following ranges:
  - EGSM: 925 – 960 MHz
  - UMTS: 2110 – 2170 MHz
  - PCS: 1930 – 1990 MHz
  - PCSG (including G block): 1930 – 1995 MHz
  - CELL: 869 - 894 MHz
  - DCS: 1805 – 1880 MHz



---

Note: The **Service DL CF** dialog displays the relevant range for each service.

---

- Click **OK**.
- Define Max expected power of BTS (0-33dBm)
- Define UL system gain for each service (5 to -15dB)

---

Notes:

1. Max expected Pin and Service CF parameters are service dependent and can be obtained from your service provider.
  2. The remaining parameters are predefined to their default values. (Service Bandwidth is set to 15 MHz for EGSM, UMTS and CELL and to 20 MHz for DCS and PCS).
  3. Any updates of the service Central Frequency definition is sent to all connected VAPs.
- 

11. To verify proper operation of the system, refer to the **Alarms** sub-tab (in the Config tab). See following figure.

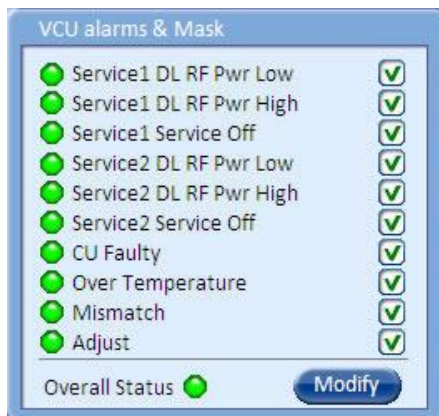

12. Verify that all the alarms are GREEN. Refer to the alarm descriptions in the table following the figure below.
13. Mask irrelevant alarm conditions to avoid having them reflected to the overall status of the unit.

Alarm	Description
Service 1 DL RF Pwr Low	RED - DL RF Power is lower by 15dBm (or more) from the Max Expected Pin.
Service 1 DL RF Pwr High	RED - the input power exceeds the maximum expected Pin by more than 3 dB.
Service 1 Service Off	User has disabled Service 1
Service 2 DL RF Pwr Low	RED - DL RF Power is lower by 15dB (or more) from the Max Expected Pin.
Service 2 DL RF Pwr High	RED - the input power exceeds the maximum expected Pin by more than 3 dB.
Service 2 Service Off	User has disabled Service 2
CU Faulty	RED - VCU fault. Remove and re-apply power to VCU. If problem persists, replace VCU.
Over Temperature	Temperature of unit exceeds normal range.
Mismatch	Red – Mismatch of services (e.g. CELL/PCS VAP connected to EGSM/UMTS VCU, VCU connected to slave VCU etc.)
Adjust	Cable (between VCU to VAP, or between Master to Slave), is too long (over 100m/300ft)
Overall Status	Indicates Fault (RED) level or GREEN if there are no faults.

### For Example

If the Dual-Band system is currently only being used to provide one service (while the other service is disabled), the "Service Off" alarm can be masked (disabled).

In the example below, the left dialog shows the alarm response if the Service 2 alarm is NOT masked (enabled). In that case the Overall Status will be RED indicating a fault.

If the Service 2 alarm is MASKED (disabled), then the LED for the alarm will be RED; but, the Overall Status will be GREEN – showing NO Fault.

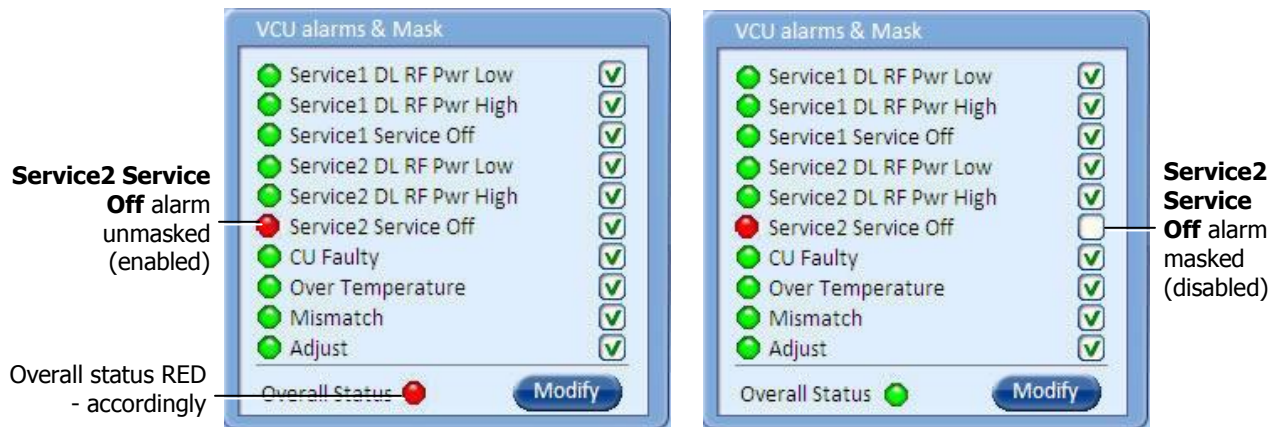

Figure 4-3. Service2 Service Off Alarm – Not Masked

Figure 4-4. . Service2 Service Off Alarm –Masked



In Figure 4-4 above, the alarm condition for "Service2 Service Off" actually exists, while the masking prevents this condition from affecting the overall status of the system and therefore the Overall Status led below is green.

Note: To briefly check the VCU status, click on the VCU name in the Topology Tree. The VCU icon will appear, showing the LEDs status.



### 4.4.3 Provisioning the Slave VCUs

Note: The Slave VCUs management and configuration is performed through a remote connection to the Master VCU, via the web management. Before provisioning the Slave VCUs verify that the Master VCU unit, to which it is connected, has been provisioned (see section 4.4.1).

The Slave VCU RF parameters are set via the Master VCU, therefore there is no need to configure the RF parameters individually for each connected Slave VCU. It is recommended to assign each Slave VCU an indicative name.

### To assign a name to a Slave VCU:

1. Connect to the Master VCU unit (either locally as explained in section 4.4.1 or remotely) and select the Slave VCU to be provisioned from the Network Topology Tree.



Each VCU has a default name of the form "VCUPx-name", where:

- **Px** - Master VCU port number to which the Slave VCU is connected
  - **Name** - user-defined name
2. To assign the Slave VCU an indicative name:
    - Select the **Module Info Tab**
    - Click the **Modify** button

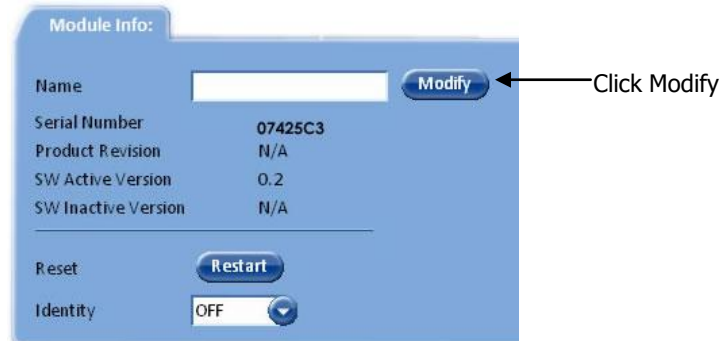

- Type the unit name (up to 17 alpha-numeric characters) and click **OK**.

# 5 VAP Installation and Provisioning

This section provides a description of the VE Access Pods (VAPs) installation, verification, and monitoring procedures.

## 5.1 VAP Installation

The VAPs installation procedure consists of connecting each VAP to the Ethernet jack in the appropriate location to provide optimal coverage (see sections 3.4 and 5.1.2).

### 5.1.1 VAP Kit Contents





The Dual-Band VE Access Pod (VAP) Kit includes:

---

Note: VAPs are provided with two mounting options: Desk Mount and Wall Mount.

---

**Table 10: VAP Kit**

Kit Items	UNIT
VE Access Pod (VAPs)	
Wall Mount Adaptor (with double sided sticky tape located on rear for fast installation)	 <p style="text-align: center;">Front                  Rear – showing tape</p>
Desk Mount Adaptor	
8 Screws: <ul style="list-style-type: none"> <li>○ 4 Short Screws – for securing adaptor to pod</li> <li>○ 4 Longer Screws – for securing wall mount adaptor to the wall (“anti-theft” installation)</li> </ul>	 <p style="text-align: center;">Long screws          Short screws</p>
RJ-45 Jumper Cable	

## 5.1.2 VAP Locations and Mounting

It is recommended to place the VAPs on top of desks, cubical walls, filing cabinets, or higher on walls so as to maximize the provided coverage per VAP.

Note: Mounting a VAP beneath a desk or in another secluded location (e.g. office corner) decreases the effective coverage of the VAP increasing the need for a higher number of VAPs to cover the same area.

When installing the VAPs, consider the following:

- Placing units in an open area.
- Availability of CAT-5e/6 infrastructure.
- The VAPs plug into standard (RJ-45) Ethernet connection jacks.
- If the jack being used is already connected to Ethernet switch. For more information see 3.4.2 and 4.3.1.
- Aesthetics of the VAP location.

### 5.1.2.1 Desk Mount

Note: All components (adaptor, screws, and cables) are included in the VAP Kit.

- Place the VAP on the Desk Mount.
- Secure the Desk Mount adaptor to the VE Access Pod using the (4) short screws.
- Connect the RJ-45 jumper cable (CAT-5e/6) to the VAP's RJ-45 connector.
- Place the VAP on a flat surface according to the planned location.
- Plug the other end of the cable into the VCU's (RJ-45) Ethernet jack.
- When using an external antenna, connect the **Ext. Antenna** SMA connector(s) to the external antenna(s). This option must be SW configured via the web GUI. (Note: Internal antenna is enabled by default).

Note: The maximum external antenna gain should not exceed 10 dBi.

- Verify that the VAP receives power and connects to the VCU via the LEDs on the unit (both the GREEN LED and the BLUE LED should be lit).



### 5.1.2.2 Wall Mount

---

Note: All components (adaptor, screws, and cables) are included in the VAP Kit.

---

- Attach the VAP's wall mount adaptor to the wall in the planned location, using the double sided sticky tape located on the rear or secure it using the longer screws.
- Place the VAP on the Wall Mount.
- Secure the Wall Mount adaptor to the VE Access Pod using the (4) short screws.
- Connect the RJ-45 jumper cable (CAT-5e/6) to the VAP's RJ-45 connector.
- Plug the other end of the cable into the VCU's (RJ-45) Ethernet jack.
- When using an external antenna, connect the **Ext. Antenna** SMA connector(s) to the external antenna(s). **This option must be SW configured via the web GUI.** (Note: Internal antenna is enabled by default).

---

Note: The maximum external antenna gain should not exceed 10 dBi.

---

- Verify that the VAP receives power and connects to the VCU via the LEDs on the unit (both the GREEN LED and the BLUE LED should be lit).

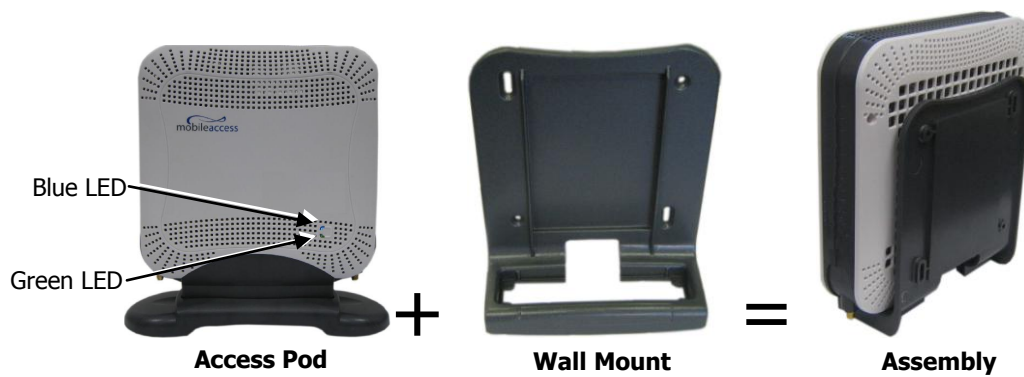

## 5.2 Verifying Coverage

Verify coverage in the areas, adding and moving VAPs for optimal coverage according to the principles described in 3.3.

## 5.3 Naming the VAPs, Verifying Connections and Monitoring

The VAPs are auto-discovered by the VCU and can be monitored via a remote or a local connection (to the Master VCU). The VAPs are auto-configured by the VCU without user intervention (no configuration procedure is required). However, if you wish, you may assign each VAP an identifiable name corresponding to its physical location.

Note: See section 6 for full explanation about navigating the MobileAccessVE Web GUI application.

1. If a session is not already open to the MobileAccessVE Web management application, open a session to the Master VCU according to section 4.4.1.

2. Select a VAP from the Network Topology Tree.

Each VAP has a default name of the form **VAP Px-name** where:

- **Px** – Number of Slave VCU port to which the VAP is connected
- **Name** - User-defined name

3. In the Network Topology Tree under the Control Unit, verify that a GREEN (or RED) circle is displayed for each connected VAP.

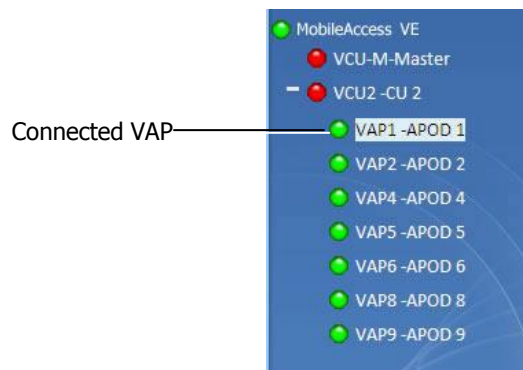

- If a VAP is not green, select the VAP from the network topology tree. Then select the Config tab. Refer to the **Alarms** tab work area. The alarms for the selected VAP are displayed.



Note: VAP alarm mask is saved in the VCU, associated with the port to which the VAP is connected. In case you replace the VAP, the newly installed VAP will automatically be set with same alarm mask.

- Refer to the Config **Module info** tab.

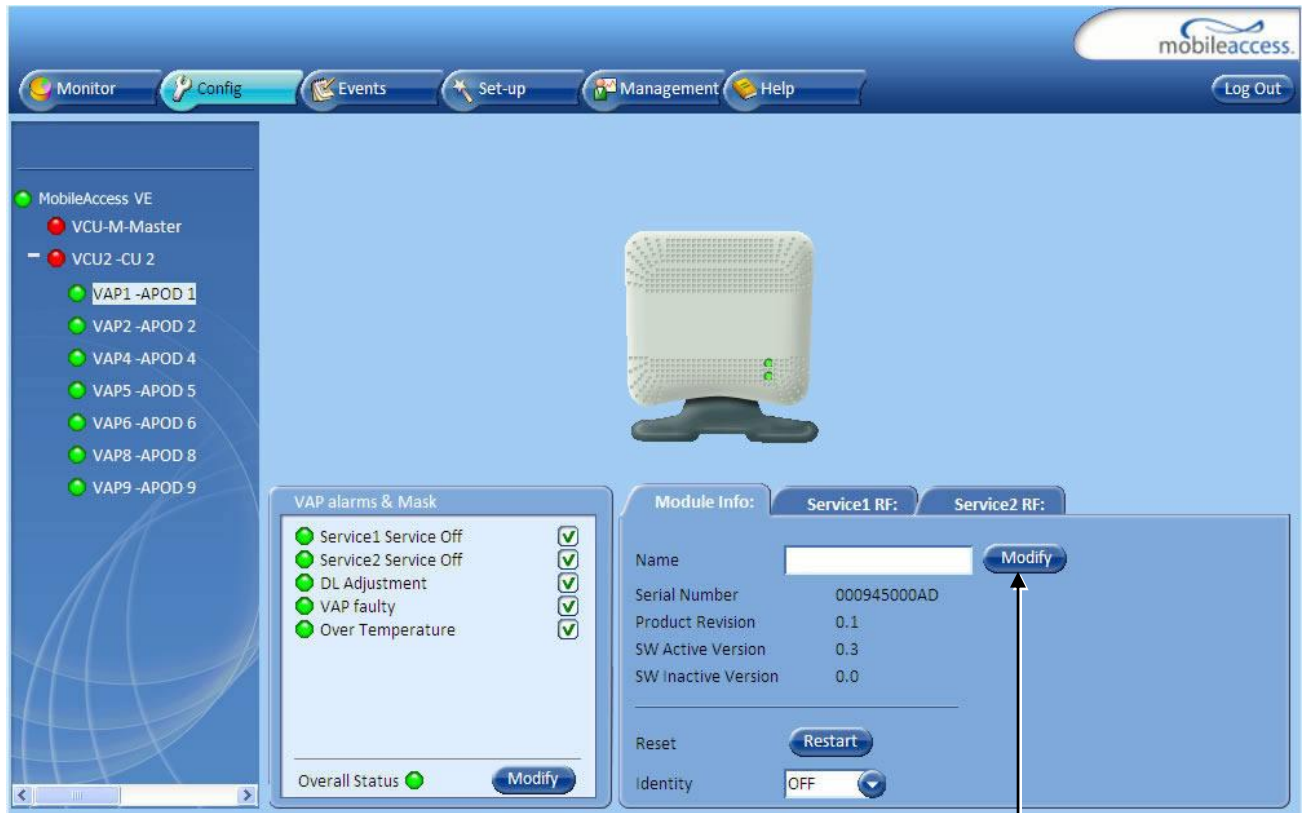

- Assign each VAP a name as follows:
  - Click the **Modify** button
  - Type the unit name (up to 17 alpha-numeric characters) and click **OK**
- When required to transmit the RF signal through a connected external antenna:
  - Refer to the **Service 1 RF** and/or **Service 2 RF** tabs
  - Enable the External Antenna option

Click Modify button to assign name

---

Note: If the external antenna option is not enabled, the signal will be transmitted via the integrated internal antenna, by default.

---

- Verify the system connections according to the following section (section 6 ).

# 6 Navigating the Web Access Application

The MobileAccess**VE** Web management application is accessed through any standard web browser connected to the Master VCU via a network within the same subnet as the Master VCU or a different subnet which is routable.

## 6.1 Opening a Session and Authentication Levels

After the initial configuration (as explained in 4.4.1) the MobileAccess**VE** system can be accessed via the network.

**To access the system:**

1. Open a web browser. In the address bar type the Master VCU's IP address as you set it in the Master VCU configuration operation (see section 4.4.1).

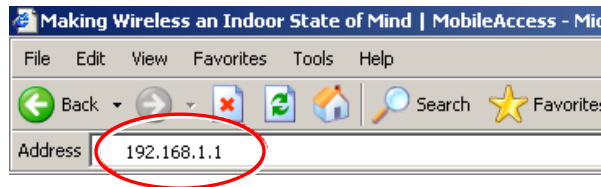

2. The Login pane appears.



Enter your User Name and password. The following authentication levels are available:

Level	Default Password	Access
operator	oper	This user has Read Only access.
engineer	eng	This user has access to basic configuration options.
admin	ma98	This user has Field Engineer permissions, in addition to access to changing passwords.



## 6.2 About the MobileAccessVE Web Access Window

The MobileAccessVE Web window includes six main tabs that provide access to the applications' main options. Here the Config tab is displayed by default.

Note: The Monitor, Events, Setup, and Help tab are future options.

The appearance of the each screen varies according to the tab displayed. The Main Menu Bar tabs are:

- Config(uration) – Displayed by default upon login. Provides the selected units' configuration parameters and alarms
- Management - Provides upgrade, IP configuration and security options

Both of these tabs are described in detail in the following sections



## 6.3 Configuration Tab

The **Configuration** tab provides the general information and service RF parameters for configuration of the units appearing in the Network Topology tree.

### To access a VCU Configuration tab

On the left hand side of the window select a Master VCU/Slave VCU from the network topology tree. Select the **Configuration** tab from the menu-bar. The information and parameters displayed in the Configuration sub-tabs vary depending on whether a VCU or VAP is selected in the topology tree.

The Configuration tab is divided in to three main areas:

- Network Topology Tree – Displays the system units (Master VCU, Slave VCUs and VAPs) and their status
- Display Area – Displays the icon of the selected unit including the LED statuses
- Work Area – Displays the Module Info, alarms, and RF tabs corresponding to the unit selected in the topology tree (Master VCU, Slave VCU or VAP)

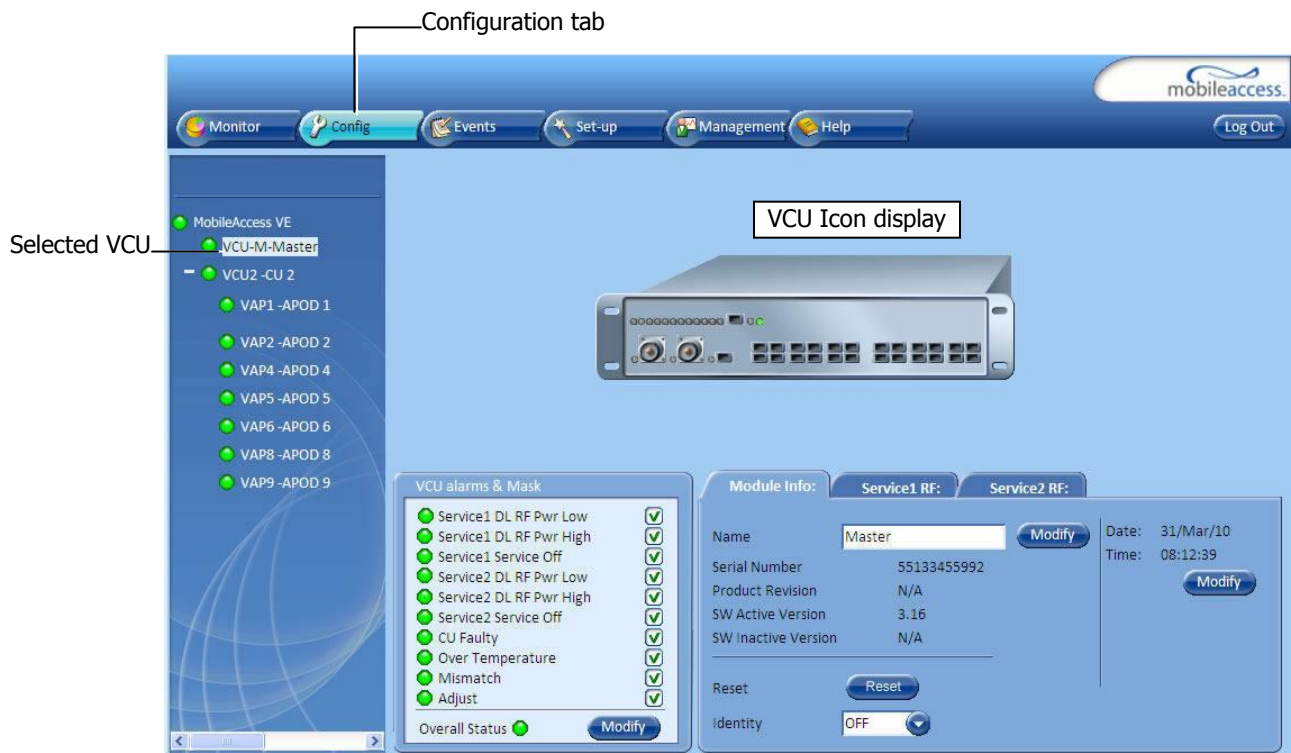

### 6.3.1 Network Topology Tree

The Configuration Network Topology Tree appears on the left hand side when the **Config** tab is selected, and displays the Master VCU, Slave VCUs, and VAPs in two levels:

- First Level – VCU
- Second Level – Up to 12 VAPs

---

Note: The root is MobileAccess VE.

---

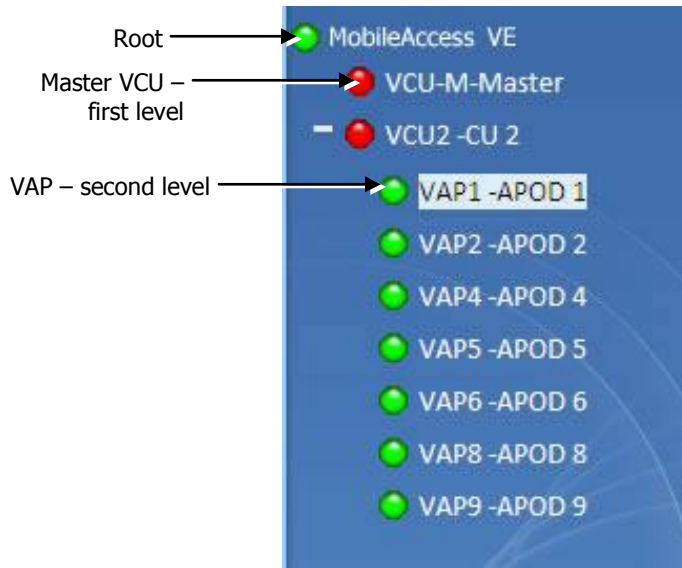

Each unit is assigned a **Type Px-name**:

- Type – VCU-M, VCU or VAP (for Master VCU, Slave VCU or VE Access Pod)
- Px - VCU port number
- Name – user defined

Each unit is displayed with a colored bullet that indicates its' status:

Color	Indicates
Green	OK
Red	Alarm Condition

The root (the entire MobileAccess**VE** site) is also associated with a colored bullet that indicates the overall status of the deployment:

Color	Indicates
Green	OK
Red	Alarm Condition in one or more VCUs or VAPs

### 6.3.2 Configuration Display Area

When selecting an element (Master VCU/Slave VCU or VAP) in the network topology tree, an icon representing the unit is displayed in the Configuration tab display area.



## 6.4 Management Tab

The Management tab provides user administrative management options and includes the sub-menu tabs:

- Firmware – Used for upgrading/downgrading SW to VCU's
- Distribute – Used for distributing the upgrade/downgrade SW files to the VAPs
- Security – Used for changing user passwords
- SNMP Config – Used for defining the SNMP communities and trap destinations
- IP Settings – Used for viewing and modifying the network parameters
- Sys(tem) Log – N/A

The following figure shows the Management screen with the menu options on left.

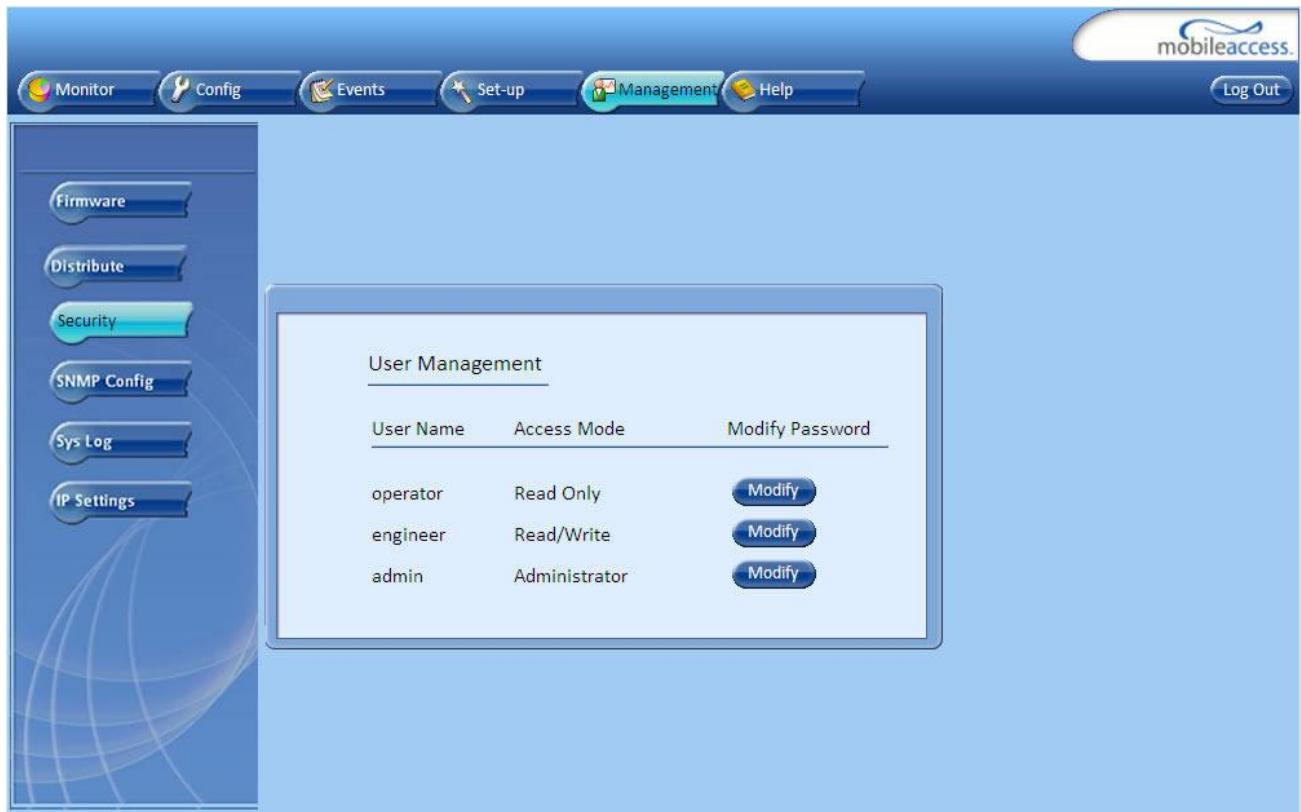

# 7 VCU Monitoring and Configuration

## 7.1 Viewing VCU General Information

The VCUs general information (such as unit name and SW versions) can be viewed in the Config **Module Info** sub-tab.

### To view VCU general information

- Click the Config tab from the main menu and select the VCU from the network topology tree. The **Module Info** sub-tab is displayed by default.



The following information is displayed:

Field	Description
Name	User defined name for system element (up to 17 characters)
Serial Number	Factory set ID number
Product Revision	Revision number of VCU/VAP
SW Active Version	Version of the SW currently being used to manage and monitor the system
SW Inactive Version	Version of other system SW version not in use
Identify Button	Enabling this option enables finding the physical location of the selected element (see 10.1). When this option is set to ON, the LEDs on the corresponding VAP/VCU flickers.
Reset Button	SW reset of the unit

## 7.2 Viewing VCU Alarms

The alarms displayed in the Alarms tab correspond to the VCU (Master/Slave) selected in the topology tree. When a VCU element is selected in the topology tree, the Alarm tab displays the main alarms in the unit.

### To view VCU Alarms

In the Topology Tree select the **Control Unit** (VCU) then click the **Config(uration)** tab in the menu bar located at the top of the window. Refer to the **VCU Alarms and Mask** sub tab.



If one or more alarms occur, the corresponding Status indicator will be illuminated in RED. If the VCU is OK and no fault occurs, the **Overall Status** indicator will show GREEN.

Alarm	Description
Service 1/2 DL RF Pwr Low	DL RF Power is lower by 15dBm (or more) from the Max Expected Pin
Service 1/2 DL RF Pwr High	The input power exceeds the maximum expected Pin by more than 3dB
Service 1/2 Service Off	User has disabled the service
Mismatch	Mismatch of services (e.g. CELL/PCS VAP connected to EGSM/UMTS VCU, etc.)
Adjust	Cable (between VCU to VAP, or between Master to Slave), is too long (over 100m/300ft)
Over Temperature	Temperature of unit exceeds normal range
CU Faulty	Hardware fault detected in VCU
Overall Status	Indicates Fault (RED) level if there are (unmasked) faults, or GREEN if there are no faults

## 7.3 Master VCU RF Parameters

Note: The RF parameters are not displayed for control units functioning as Slave VCUs.

### To access the Service RF tab

Click the **Config** tab from the main menu bar and then select the Master control unit from the network topology and click the *Service RF* tab. The parameters displayed in Service RF tabs correspond to the selected element.

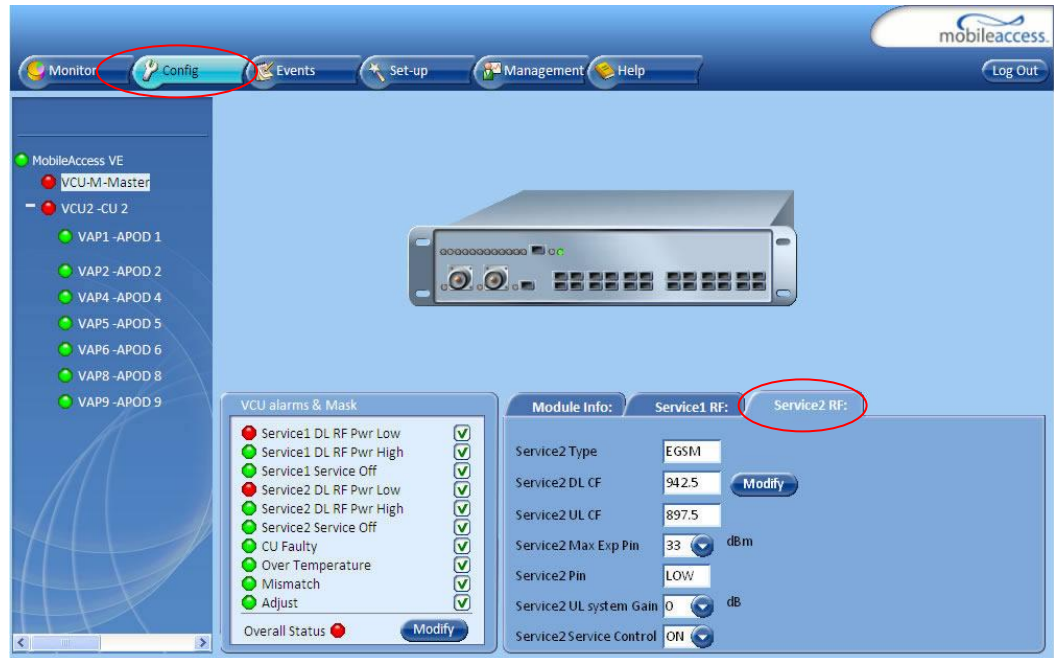

The following table provides a description of the RF parameters displayed in the Service RF tabs.

Parameter	Description
Type	Set (read only) according to unit type (e.g. EGSM / UMTS)
DL CF*	DL Center frequency (from BTS). User defined, according to connected service (EGSM / UMTS / CELL / PCS / DCS)
UL CF	UL center frequency (from BTS) – corresponding to defined DL Center Frequency. Automatically assigned by the system according to the DL frequency
Max Exp Pin*	Maximum expected input power from the BTS. Used for adjustment procedure. Range: 0-33 dBm. User defined
Pin	Actual measured Pin (read only)
UL System Gain	Used for adjusting the UL system gain. Range: -15dB to +5dB
Service Control	Enables (On)/Disables (Off) the service

\* Required parameters to be provisioned by the user.



## 8 VAP Monitoring and Configuration

### 8.1 Viewing VAP General Information

The VAPs general information (such as unit name and SW versions) can be viewed in the Config **Module Info** sub-tab.

#### To view VAP general information

Click the Config tab in the main menu and select the VAP from the network topology tree. The **Module Info** sub-tab will be displayed by default.

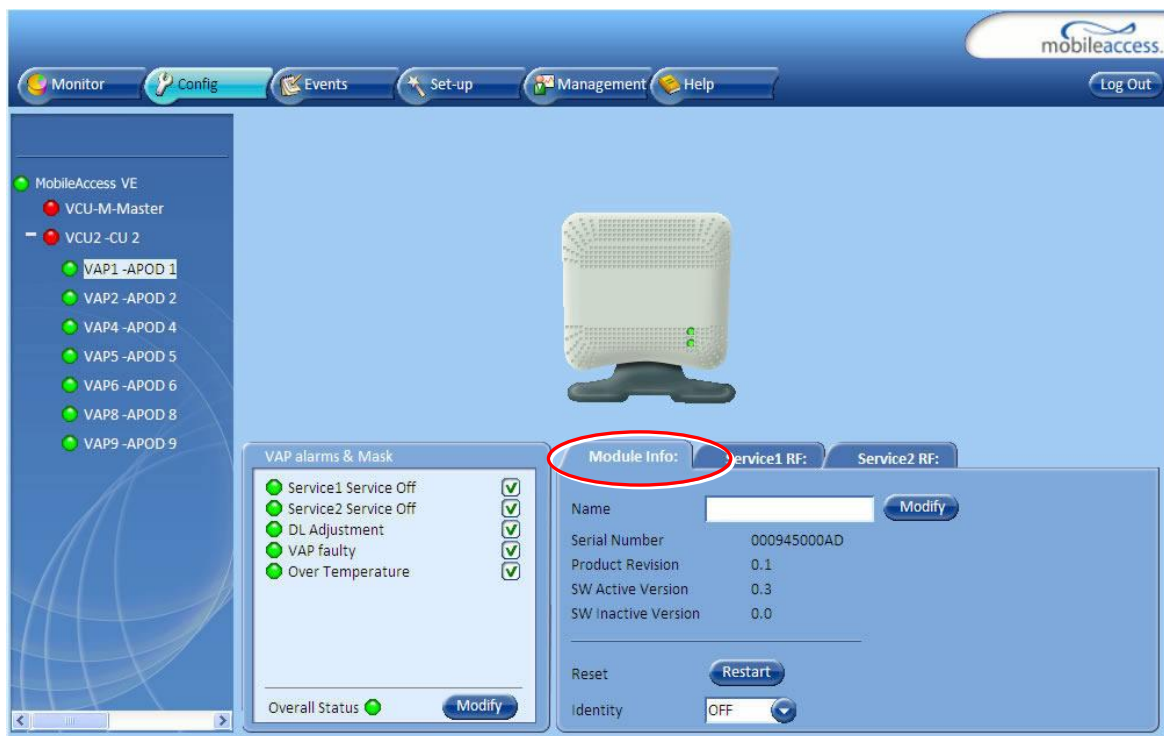

The following information is displayed:

Field	Description
Name	User defined name for system element (up to 17 characters)
Serial Number	Factory set ID number
Product Revision	Revision number of VCU/VAP
SW Active Version	Version of the SW currently being used to manage and monitor the system
SW Inactive Version	Version of other system SW version not in use
Identify Button	Enabling this option enables finding the physical location of the selected element (see 10.1). When this option is set to ON, the LEDs on the corresponding Access POD/VCU flickers.
Reset Button	SW reset of the unit

Note: VAP Name is saved in the VCU associated to the port to which the VAP is connected, such that in case you replace a VAP, the new one will be associated with the same name.

## 8.2 Viewing VAP Alarms

When a VAP element is selected in the topology tree, the Alarm tab displays the main alarms in the unit.

### To access VAP Alarms Tab

Click the Config tab in the main menu and select the VAP from the network topology tree. Select the **VAP Alarms** sub tab.

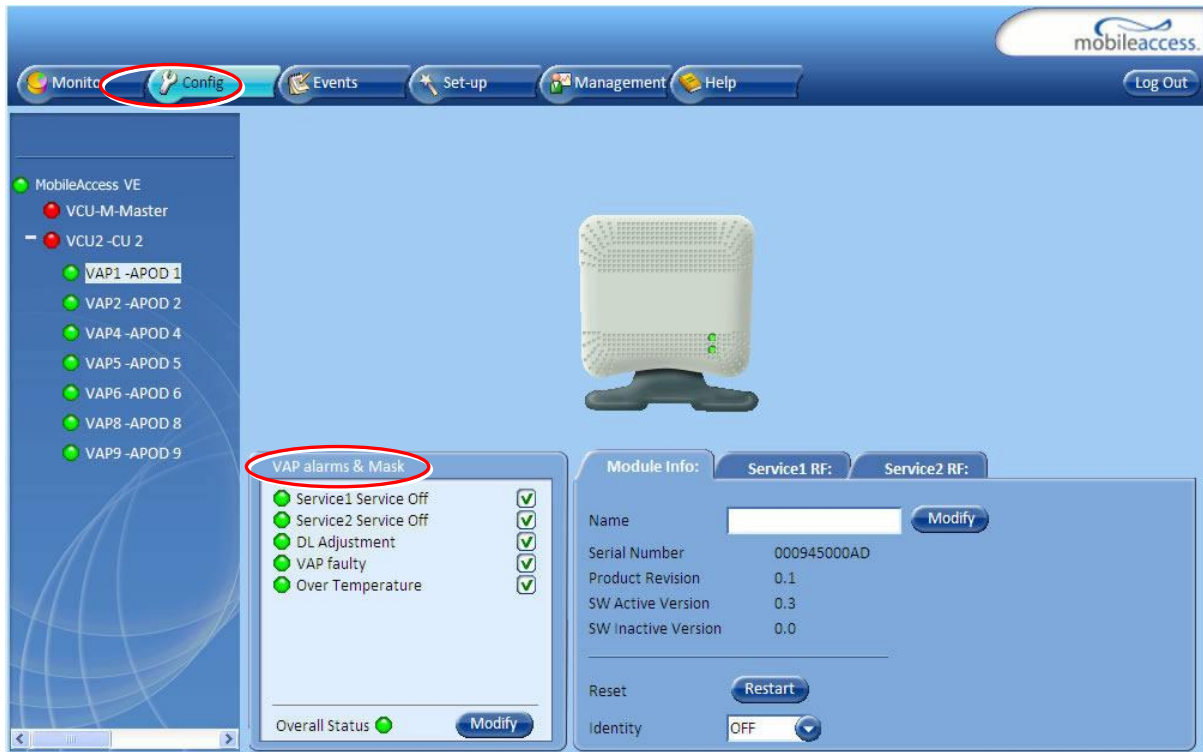

If one or more alarms occur, the corresponding Status indicator will be illuminated in RED. If the VAP is OK and no fault occurs, the **Overall Status** indicator will show GREEN.

Alarm	Description
Service 1/2 Off	User has disabled the service
DL Adjustment	Cable (between VCU to VAP) is too long (over 100m/300ft)
VAP Faulty	A fault has been detected in the VAP
Overall Temperature	Temperature of unit exceeds normal range
Overall Ttatus	Indicates Fault (RED) level or GREEN if there are no faults

Note: DL adjustment alarm is raised when a VAP is connected over a cable exceeding system cable length limitation. In such cases, the system continues to provide the wireless services, but you should check the coverage of the VAP (as output power may be degraded due to excess cable loss) and check the Ethernet connection (as Ethernet standard maximum cable length has probably been exceeded).

## 8.3 VAP RF Parameters

The **Service 1** and **Service 2** tabs provide the configurable RF parameters corresponding to the VAP element selected in the network topology tree. Up to two service RF tabs are displayed, one for each service. The displayed RF parameters are similar for both service tabs.

### To view the VAP RF Parameters

Click the **Config** tab from the main menu bar and then select the VAP from the network topology and click the *Service RF* tab. The parameters displayed in Service RF tabs correspond to the selected element.

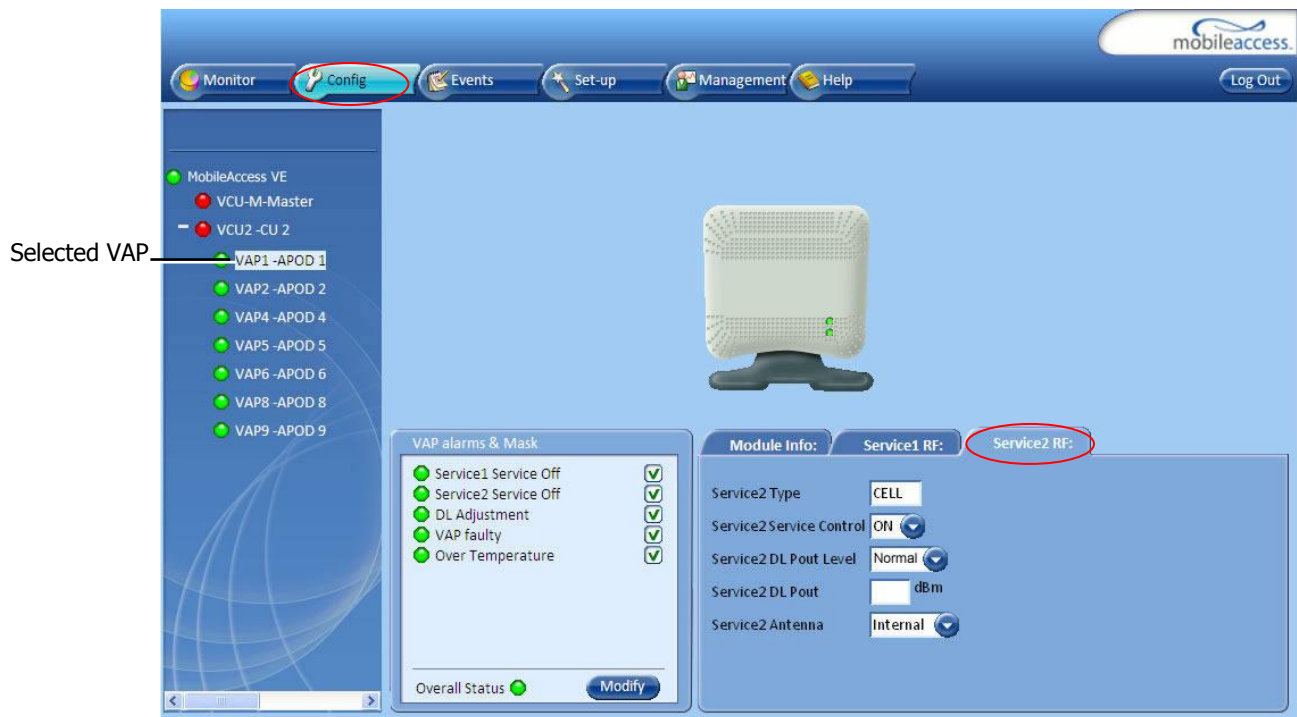

The following table provides a description of the RF parameters displayed in the Service RF tabs.

Parameter	Description
Type	Set according to unit type (e.g. EGSM /UMTS)
Service Control	Used to Disable (Off) or Enable (On) the service for the specific VAP
DL Pout Level	Normal – Pout from the VAP at normal level (according to the service) Low – Pout from VAP is attenuated by 5 dB
DL Pout	Presents the measured output power
Antenna	Select External only if an external antenna is connected to this VAP. Otherwise, the option should be set to Internal (default)

Note: VAP RF settings (Service Control, DL Pout Level, Antenna) are saved in the VCU associated to the port to which the VAP is connected, such that in case you replace a VAP all parameters are automatically set to the new VAP.

## 9 Administrative Operations

This chapter describes the following Administrative operations:

- Changing password
- IP configuration parameters
- SNMP Configuration parameters
- Unit software upgrade and software management procedures

### 9.1 Changing Password

The Management - Security tab provides password change options.

#### To set the application password or change an existing password

1. Select the **Security** option of the Management tab at the top of the window.



2. Click the **Modify** button beside the User Name whose password is being modified.
3. Enter the **New Password** and re-enter in the **Confirm New Password** field.
4. Click **OK**.

---

Note: Passwords can only be changed when connected as an administrator.

---

## 9.2 IP Settings

The IP Settings tab is used for viewing and modifying the network parameters. The default parameter settings are as follows:

- IP Address: 192.168.1.1
- Subnet Mask: 255.255.255.0
- Default Gateway: 192.168.1.254

The screenshot shows the mobileaccess web interface. The top navigation bar includes Monitor, Config, Events, Set-up, Management, and Help. The left sidebar contains links for Firmware, Distribute, Security, SNMP Config, Sys Log, and IP Settings. The main content area displays the 'Lan Port' configuration page with the following settings:

Lan Port	
DHCP	None
IP Address	192.168.1.1
Subnet Mask	255.255.255.0
Default Gateway	192.168.1.254
MAC Address	00:26:6D:00:09:62

Below the settings is a 'Modify' button. An arrow points to this button with the text: Click **Modify** button to change settings.

## 9.3 SNMP Configuration Parameters

The SNMP Config tab is used for defining the SNMP communities in which the devices and management station belongs and to where the traps are sent. The SNMP default communities are:

- Read - public
- Write - private

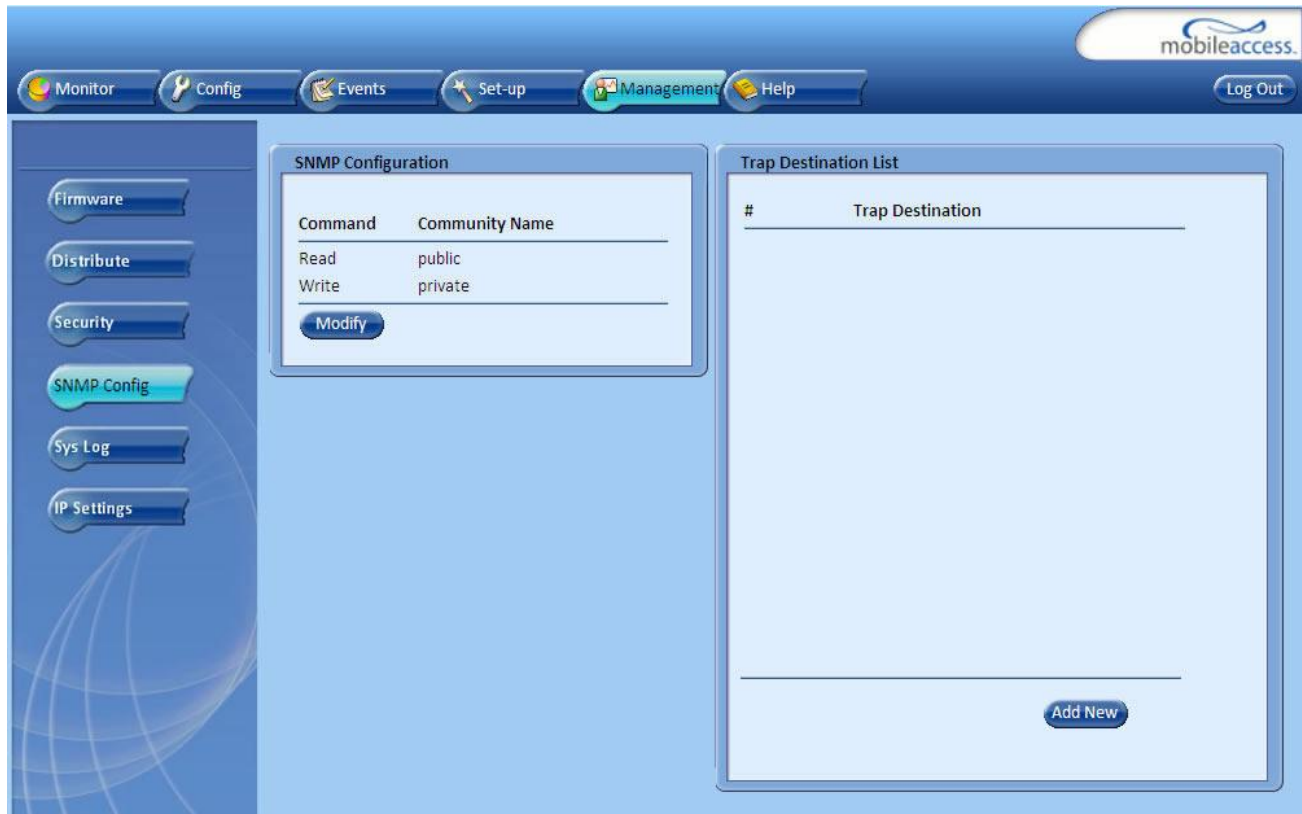

- The Community Names can be modified by clicking the **Modify** button in the SNMP Configuration display area.
- Additional Trap Destinations can be added by clicking the **Add New** button in the Trap Destination List display area:

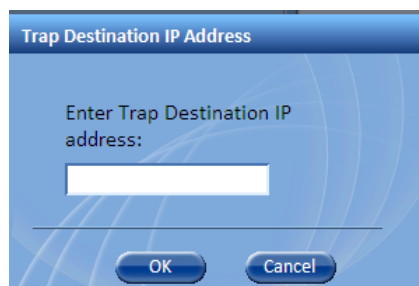

## 9.4 Upgrading (or Downgrading) VCU and VAP Software

---

NOTE: Before you start, verify that the VCU and VAPs upgrade files are located in an accessible location (i.e. on your computer).

---

The software for each VCU and its hosted VAPs can be upgraded through access to the VCU.

---

Note: In installations with Slave VCUs, a session should be opened to the IP address of the Slave VCU in order to upgrade the SW of the Slave VCU and associated VAPs.

---

Two types of files are stored on the VCU and on individual VAPs: Active software on which the unit operates, and Standby software. The Active and Standby software can be swapped on each individual unit.

In addition, the VCU holds two software images for VAPs – to be used in download process to VAPs.

The upgrade procedure consists of the following main phases:

1. Uploading the new VCU and VAP software to the host VCU.
2. Setting the new software as the Active software.
3. Activating the new VCU software on the VCU.
4. Downloading the new software to selected VAPs and activating it as the Active software on those VAPs.

The procedure is performed via two screens:

- Firmware Screen – used to manage the software files stored on the VCU.
- Distribute Screen – used to download the VAP software version to selected VAPs.

## 9.4.1 Upgrading the VCU SW

### To Upgrade the VCU SW Version:

1. Upload the VCU upgrade files from your storage location (i.e. computer) to the VCU as follows:
  - Click the **Management** menu tab and then select the **Firmware** sub-menu option found on the left side.

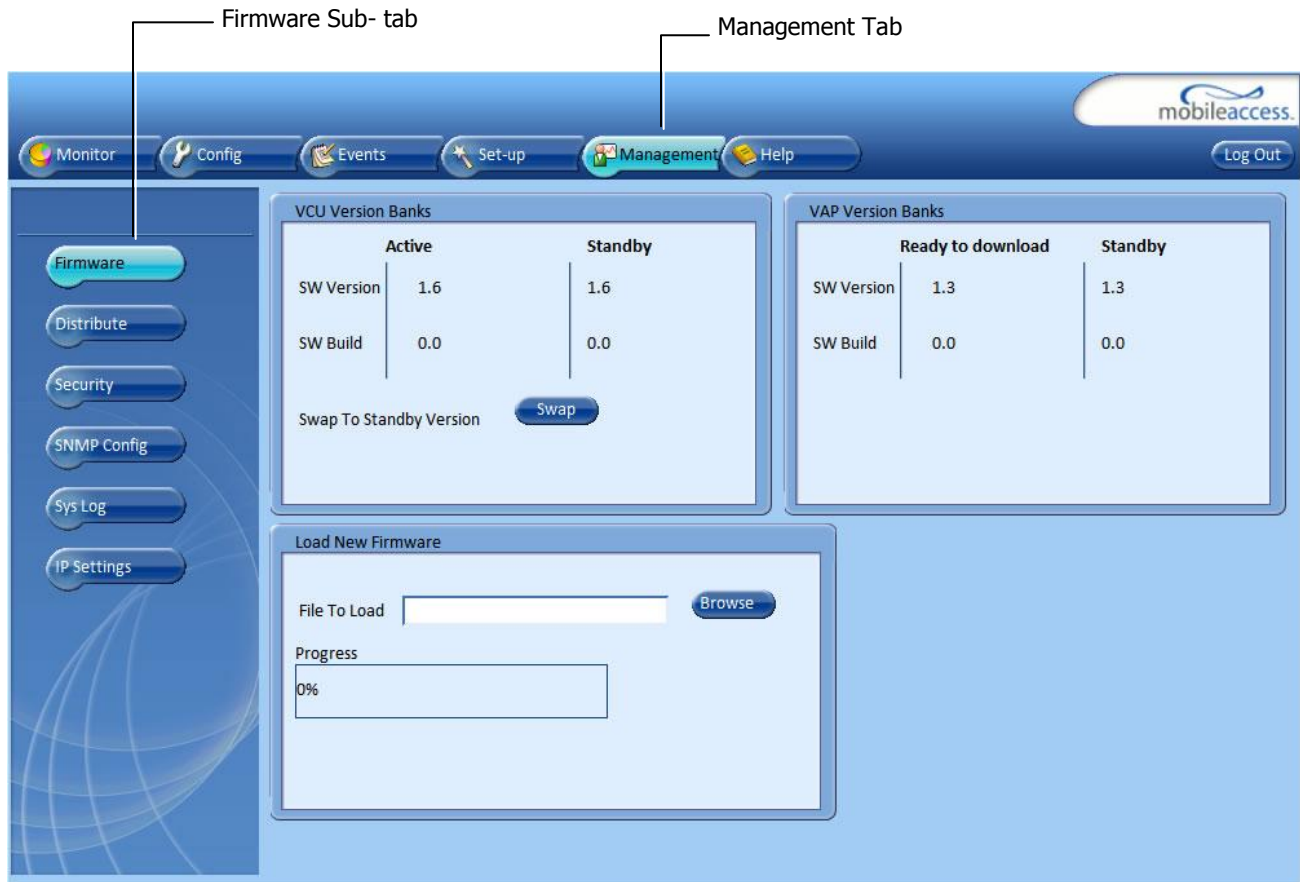

- In the **Load New Firmware** display area, click the **Browse** button.
  - Select the file to be loaded from your computer location. The Download button appears and the progress bar will show the download status.
  - After the download is complete the downloaded SW version will appear in the Standby Bank column of the VCU display area.
2. Define the downloaded version as the Active version (to be used for upgrade) as follows:
    - (In the VCU display area), click **Swap**. The downloaded version appears in the Active Bank column and the Controller is automatically restarted.
    - The VCU Upgrade procedure is complete.



## 9.4.2 Upgrading the VAP SW

### To Upgrade the VAPs SW Version:

1. Upload the VAP upgrade files from your storage location (i.e. computer) to the VCU as follows:
  - Click the **Management** menu tab and then select the **Firmware** sub-menu option located on the left side.
  - In the **Load New Firmware** display area, click the **Browse** button.
  - Browse for the file to be loaded from your computer location. The Download button appears and the progress bar will show the download status.

The screenshot shows the mobileaccess web GUI. At the top, there is a navigation bar with tabs: Monitor, Config, Events, Set-up, Management (selected), and Help. A 'Log Out' button is in the top right. On the left, a vertical menu contains: Firmware (selected), Distribute, Security, SNMP Config, Sys Log, and IP Settings. The main content area is divided into three sections:

- VCU Version Banks:** A table with columns 'Active' and 'Standby'.
 

	Active	Standby
SW Version	1.6	1.6
SW Build	0.0	0.0

 Below the table is a 'Swap To Standby Version' label and a 'Swap' button.
- VAP Version Banks:** A table with columns 'Ready to download' and 'Standby'.
 

	Ready to download	Standby
SW Version	1.3	1.3
SW Build	0.0	0.0
- Load New Firmware:** A form with a 'File To Load' input field, a 'Browse' button, and a 'Progress' bar showing 0%.

A red box highlights the 'Load New Firmware' area, with a red arrow pointing to it from the text 'Load New Firmware display area' on the left.

- After the download is complete, the downloaded SW version will appear in the Standby Bank column of the VAP display area.

#### Notes:

1. Locate the Firmware files on your local hard-drive prior to the download process.
2. During the download process DO NOT disconnect the Web GUI connection to the VCU.

2. To distribute the new software to selected VAPs:
  - Select the **Distribute** sub-menu option found on the left side.

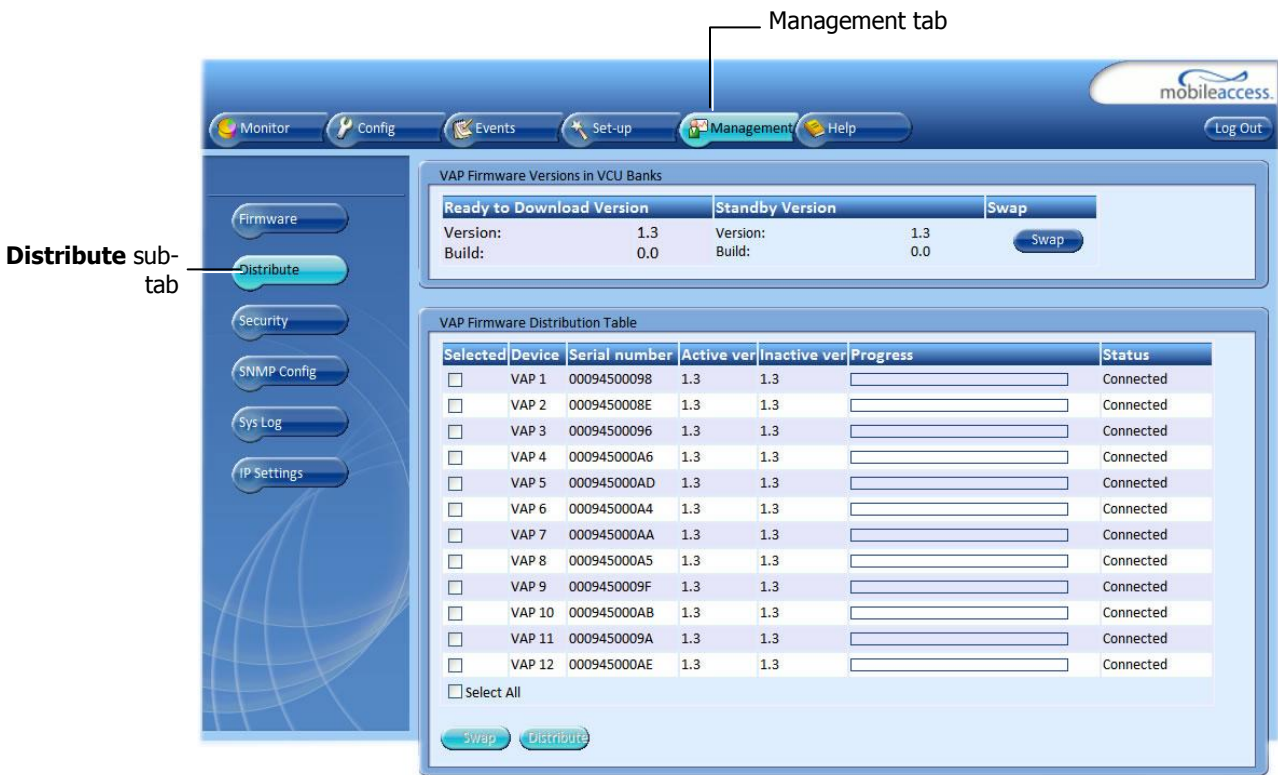

3. Download the new version to the selected VAPs (Note: The downloaded version is stored as Inactive in the VAPs until a Swap procedure is performed.)
  - In the **VAP Distribute Table** display area, checkmark the VAPs to be upgraded. The Active and Inactive SW versions for each VAP are listed in the relevant columns.
  - Click the **Distribute** button to download the new software to the selected VAPs. The software is stored as the Inactive version in the VAPs.
  - Set the new software as the Active version in the selected VAPs by clicking the Swap button.
  - The VAP upgrade procedure is complete.

Notes:

1. As during the distribution process service may be interrupted, it is advised to perform the SW download and distribution in a maintenance window scheduled at off-peak hours (e.g. nights and/or weekends).
2. During the distribution process DO NOT perform configuration changes, connect or disconnect VAPs, and/or disconnect the web GUI.
3. After the distribution process is complete and swapping between VAP SW images, the VCU will restart automatically. After restart, the VAP firmware distribution table will be empty. Within several seconds it will re-populate as the VCU re-discovers connected VAPs.

# 10 Troubleshooting

## 10.1 Finding a Specific VAP in the Building

It is recommended to assign each VAP an identifiable name corresponding to its physical location, as explained in section 5.3. If a name was not configured, or for some other reason a specific VAP cannot be physically located, identify the VAP according to the instructions in the following example.

### To locate a VAP

1. Select the **Config** tab from the main menu bar and then select the VAP to be located from the topology tree.

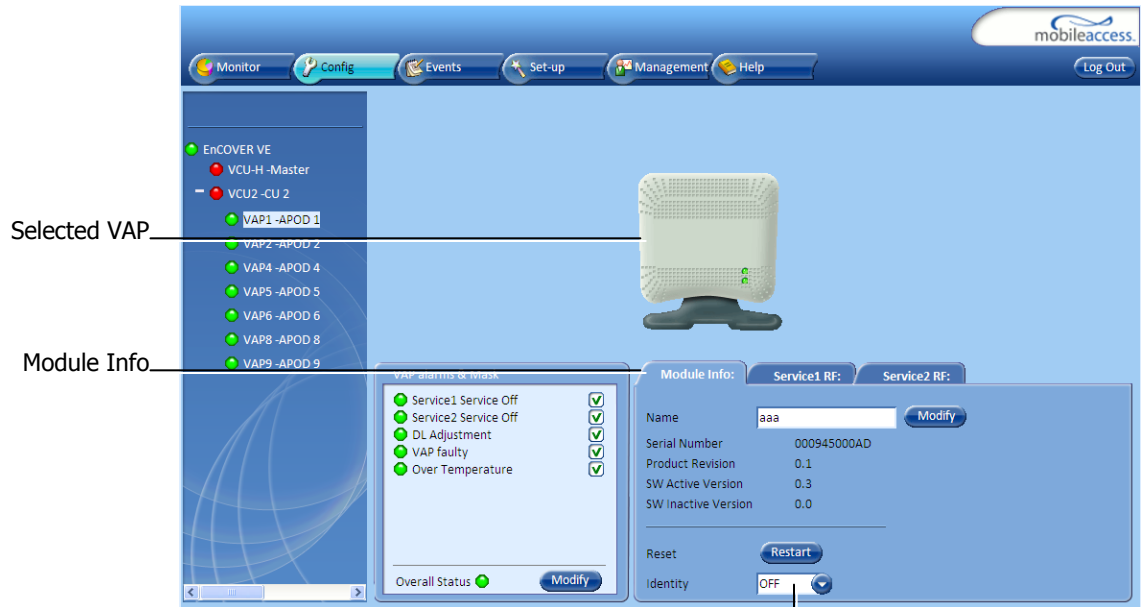

2. Click the **Module Info** sub-tab.

3. Set **Identify** to **ON**. The Activity LED (Blue) on the corresponding Access Pod will start blinking fast. (You will need to physically locate the VAP to see the blinking LED).



4. Locate the Access Pod.
5. It is advisable to assign it an identifiable name via the Access Pod **Module Info** tab, as described in section 5.3 (e.g. floor 3, room 2) and set the **Identify** field to **Off** again.

## 10.2 Wireless Service is Not Available

1. Verify that the Master VCU is connected to the BTS, powered up, and configured.

Verify that the Max Expected Power setting is correct by either:

- A) Viewing the actual VCU Power Measurement (**Service Pin**) in the VCU **Service RF** tab (see below).

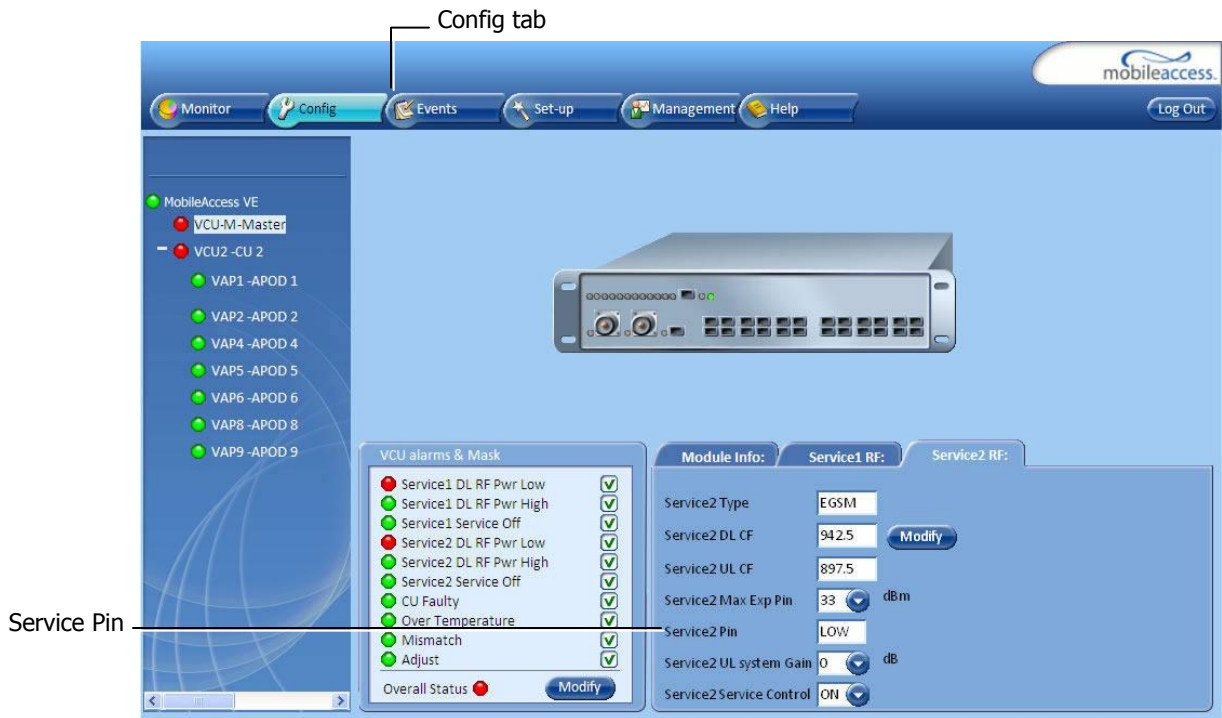

- B) Measuring the actual BTS output using a Spectrum Analyzer.
2. Verify correct settings of Frequencies and UL Gain (see **DL/UL CF** and **UL System Gain** parameters in Service RF sub-tab displayed above).
  3. Verify that the RF cables are properly connected to the VCU.
  4. View the VCU **Alarms** (above image) and verify that the VCU is working properly.

## 10.3 PoE is Not Working

Verify that the PoE used is "alternative a". The MobileAccessVE system currently only supports this alternative. Verify that all pairs are wired in the patch panels and jumper cords.

---

Note: Future enhancements will support "alternative b". Consult MobileAccess if you currently require support for "alternative b."

---

## 10.4 Ethernet Service is Degraded

Ethernet standards specify that 100m (300ft) is the maximum distance between an Ethernet switch and appliance (computer, WLAN AP, etc). This is relevant when MobileAccess**VE** shares the IT LAN. The distance includes all patch cords (from switch to VCU, from VCU to patch panel, from RJ-45 outlet to VAP, and from VAP to appliance).

1. Review the IT documentation, which may be available from your IT department, to determine cable types and lengths.
2. Check the lengths of the patch cords being used and verify the end-to-end distance does not exceed 100m (300ft).
3. A Fluke cable tester can be used to measure cable length.

## 10.5 No Service from Connected Access Pod

This requires physically accessing the Access Pod to check the LEDs, and accessing the Access Pod through the Web GUI to verify the Access Pod configuration.

1. Physically view the Access Pod and confirm that both LEDs on the Access Pod are lit:
  - Power LED (Green) is OFF – either no connectivity to the VCU or the VAP is faulty. Try replacing the VAP. Try connecting the VAP directly to the VCU – if the Power LED is lit check the cable and the patch cords.
  - Activity LED is constantly blinking – the Access Pod cannot initialize due to exceeded cable length. Try using the closest free RJ-45 jack fed with a different cable.



2. Check other Access Pods connected to the same VCU.
3. Verify that the VAP configuration as follows:
  - Connect to the VCU using the MobileAccess**VE** Web GUI application (see 6.1) and select the VAP from the topology tree.



- In the **Config** tab, click on the relevant **Service RF** sub-tab and verify that the Service Control parameter is set to **On**.
- Confirm that the VCU port is functioning (VAP status LED associated with this Pod is green).
- In case external antennas are connected – verify the VAP was configured to use the external antennas (see **Antenna** parameter in VAP Service RF sub-tab, shown above).

## 10.6 VCU Cannot be monitored via SNMP

VE traps are not received by the external Fault Monitoring system.

1. Verify that the VCU is powered ON.
2. Verify that the SNMP traps destination address is configured correctly.
3. Verify the IP connectivity to the Fault Monitoring server using "ping."
4. Verify that SNMP port is not blocked or fire-walled in the IP network.
5. Initiate an Alarm and confirm the trap is received by external Fault Monitoring server. For example:
  - Access the VAP Service RF sub-tab (see section 8.3).

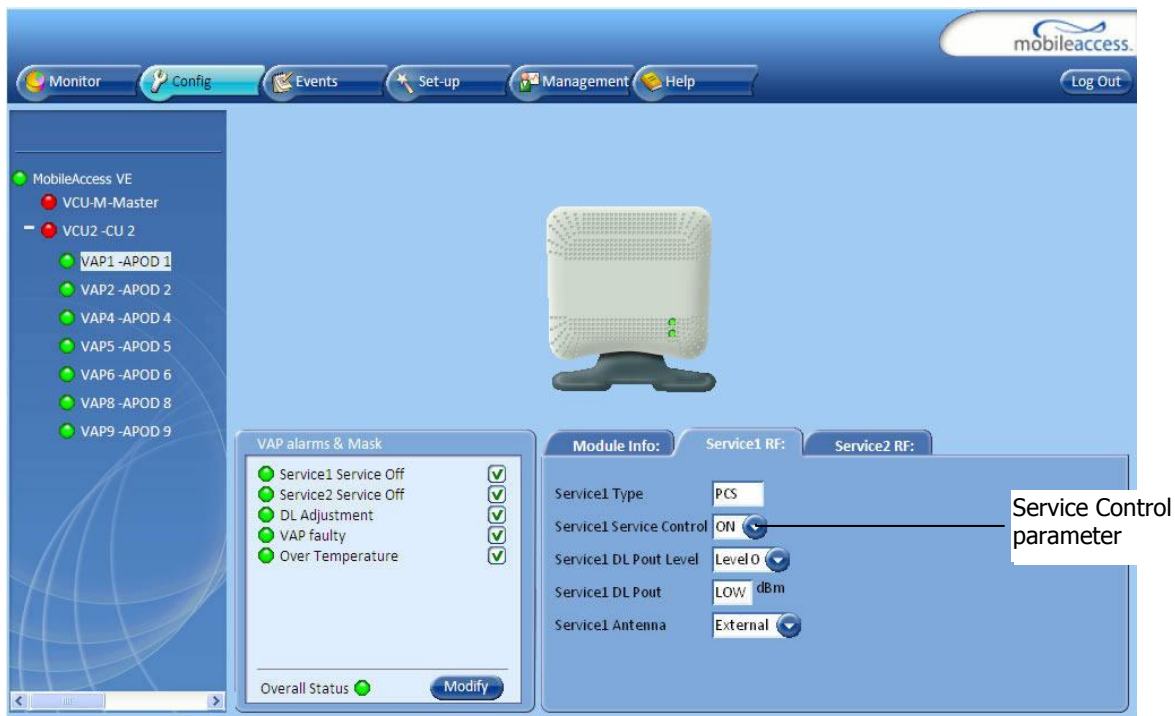

- Verify that the alarm is unmasked.
- Set the **Service Control** parameter to **Off**.
- Confirm the trap is received by external Fault Monitoring server.



# Appendix A - Traps

This section lists the MobileAccessVE Dual-Band Controller and Access Pod Traps.

## VE Control Unit (VCU) Traps

Trap Name	Trap Description
vcuChannel_1_DLPowerLow	(Major) Alert for low RF in VCU for Service 1: 15dB less than max expected power
vcuChannel_1_DLPowerHigh	(Minor) Alert for High RF in VCU for Service 1: 3dB more than max expected power
vcuChannel_1_ServiceOff	(Major) User set Service 1 to off
vcuChannel_2_DLPowerLow	(Major) Alert for low RF in VCU for Service 2: 15dB less than max expected power
vcuChannel_2_DLPowerHigh	(Minor) Alert for High RF in VCU for Service 2: 3dB more than max expected power
vcuChannel_2_ServiceOff	(Major) User set Service 2 to off
vcuFault	(Major) HW failure in VCU
vcuOverTemperature	(Minor) VCU temperature is too high
vcuMismatchType	(Minor) When VCU services types is different than VAP services types
vcuAdjustment	(Major) When adjustment (for Slave VCU) has failed (cable too long)

## VE Access Pod (VAP) Traps

Trap Name	Trap Description
vapAdjustment	(Major) Cable is too long (over 100m/300ft)
vapChannel_1_ServiceOff	(Minor) User set service 1 to Off
vapChannel_2_ServiceOff	(Minor) User set service 2 to Off
vapFaulty	(Major) The Access Pod is faulty
vapOverTemperature	(Minor) VAP temperature is too high