

Save This Manual
For Future Reference

SEARS

**owners
manual**

**MODEL NO.
113.198310**

**10" RADIAL SAW
WITH 44" CABINET**

Serial
Number _____
Model and serial numbers
may be found on the
backside of the base.
You should record both
model and serial number
in a safe place for future
use.

CAUTION:

**READ ALL
INSTRUCTIONS
CAREFULLY**

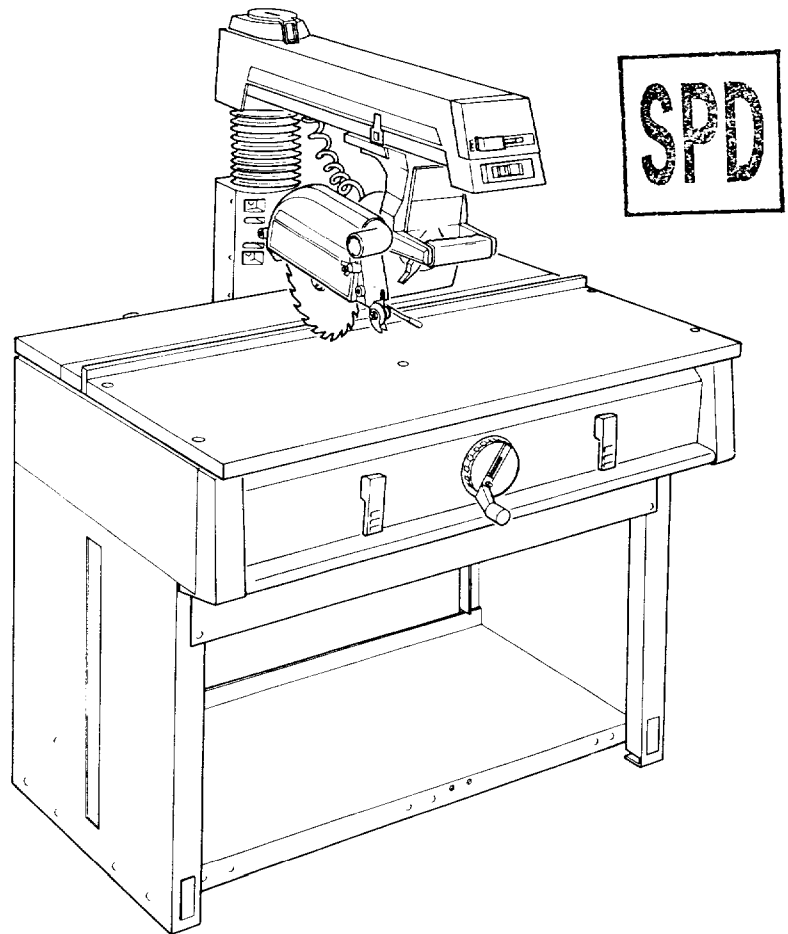

CRAFTSMAN

10-INCH RADIAL SAW

- **assembly**
- **operating**
- **repair parts**

Sold by SEARS, ROEBUCK AND CO., Chicago, IL. 60684 U.S.A.

Part No. SP5015

Printed in U.S.A.

FULL ONE YEAR WARRANTY ON CRAFTSMAN RADIAL SAW

If within one year from the date of purchase, this Craftsman Radial Saw fails due to a defect in material or workmanship, Sears will repair it, free of charge.

WARRANTY SERVICE IS AVAILABLE BY SIMPLY CONTACTING THE NEAREST SEARS SERVICE CENTER/DEPARTMENT THROUGHOUT THE UNITED STATES.

This warranty applies only while this product is used in the United States.

This warranty gives you specific legal rights and you may also have other rights which vary from state to state.

SEARS, ROEBUCK AND CO., DEPT. 698/731A Sears Tower, Chicago, IL 60684

GENERAL SAFETY INSTRUCTIONS FOR POWER TOOLS

- 1. KNOW YOUR POWER TOOL**
Read and understand the owner's manual and labels affixed to the tool. Learn its application and limitations as well as the specific potential hazards peculiar to this tool.
- 2. GROUND ALL TOOLS**
This tool is equipped with an approved 3-conductor cord and a 3-prong grounding type plug to fit the proper grounding type receptacle. The green conductor in the cord is the grounding wire. Never connect the green wire to a live terminal.
- 3. KEEP GUARDS IN PLACE,**
in working order, and in proper adjustment and alignment.
- 4. REMOVE ADJUSTING KEYS AND WRENCHES**
Form habit of checking to see that keys and adjusting wrenches are removed from tool before turning it on.
- 5. KEEP WORK AREA CLEAN**
Cluttered areas and benches invite accidents. Floor must not be slippery due to wax or sawdust.
- 6. AVOID DANGEROUS ENVIRONMENT**
Don't use power tools in damp or wet locations or expose them to rain. Keep work area well lighted. Provide adequate surrounding work space.
- 7. KEEP CHILDREN AWAY**
All visitors should be kept a safe distance from work area.
- 8. MAKE WORKSHOP CHILD-PROOF**
— with padlocks, master switches, or by removing starter keys.
- 9. DON'T FORCE TOOL**
It will do the job better and safer at the rate for which it was designed.
- 10. USE RIGHT TOOL**
Don't force tool or attachment to do a job it was not designed for.
- 11. WEAR PROPER APPAREL**
Do not wear loose clothing, gloves, neckties or jewelry (rings, wrist watches) to get caught in moving parts. Nonslip footwear is recommended. Wear protective hair covering to contain long hair. Roll long sleeves above the elbow.
- 12. USE SAFETY GOGGLES (Head Protection)**
Wear Safety goggles (must comply with ANSI Z87.1) at all times. Everyday eyeglasses only have impact resistant lenses, they are NOT safety glasses. Also, use face or dust mask if cutting operation is dusty, and ear protectors (plugs or muffs) during extended periods of operation.
- 13. SECURE WORK**
Use clamps or a vise to hold work when practical. It's safer than using your hand, frees both hands to operate tool.
- 14. DON'T OVERREACH**
Keep proper footing and balance at all times.
- 15. MAINTAIN TOOLS WITH CARE**
Keep tools sharp and clean for best and safest performances. Follow instructions for lubricating and changing accessories.
- 16. DISCONNECT TOOLS**
before servicing; when changing accessories such as blades, bits, cutters, etc.
- 17. AVOID ACCIDENTAL STARTING**
Make sure switch is in "OFF" position before plugging in.
- 18. USE RECOMMENDED ACCESSORIES**
Consult the owner's manual for recommended accessories. Follow the instructions that accompany the accessories. The use of improper accessories may cause hazards.
- 19. NEVER STAND ON TOOL**
Serious injury could occur if the tool is tipped or if the cutting tool is accidentally contacted. Do not store materials above or near the tool such that it is necessary to stand on the tool to reach them.
- 20. CHECK DAMAGED PARTS**
Before further use of the tool, a guard or other part that is damaged should be carefully checked to ensure that it will operate properly and perform its intended function. Check for alignment of moving parts, binding of moving parts, breakage of parts, mounting, and any other conditions that may effect its operation. A guard or other part that is damaged should be properly repaired or replaced.
- 21. DIRECTION OF FEED**
Feed work into a blade or cutter against the direction of rotation of the blade or cutter only.
- 22. NEVER LEAVE TOOL RUNNING UNATTENDED**
Turn power off. Don't leave tool until it comes to a complete stop.

additional instructions for radial arm saws

BEFORE USING THE SAW:

WARNING: TO AVOID MISTAKES THAT COULD RESULT IN SERIOUS, PERMANENT INJURY, DO NOT CONNECT POWER CORD UNTIL THE FOLLOWING STEPS HAVE BEEN SATISFACTORILY COMPLETED:

1. Assembly and alignment. (See pages 9-22)
2. Examination and operating familiarity with ON-OFF switch, elevation hand wheel, swivel lock, bevel lock and rip lock, guard clamp screw, spreader and anti-kickback device and miter lock. (See pages 23-26)
3. Review and understanding of all safety instructions and operating procedures throughout the manual.

Read the following danger labels which appear on the front of the radial arm saw base assembly, motor and saw guard:

DANGER

FOR YOUR OWN SAFETY:

1. Read and understand owner's manual before operating machine.
2. Wear safety goggles complying with ANSI Z87.1.
3. Keep hands out of path of saw blade.
4. Know how to avoid "KICKBACKS".
5. Use "PUSH STICK" for narrow work.
6. Never reach around the saw blade.
7. Never perform any operation "FREEHAND".
8. Return carriage to the full rear position after each cross-cut type operation.
9. Shut off power and allow saw blade to stop before adjusting or servicing.

DANGER WHEN RIPPING

1. Read and understand owner's manual before operating machine.
2. Wear safety goggles complying with ANSI Z87.1.
3. Keep hands out of path of saw blade.
4. Know how to avoid "KICKBACKS".
5. Use "PUSH STICK" for narrow work before operating machine.
6. Never reach around the saw blade.
7. Never perform any operation "FREEHAND".
8. Shut off power and allow saw blade to stop before adjusting or servicing.

TO AVOID RUNAWAY WORKPIECE
ALWAYS RIP WORKPIECE INTO CUTTING TOOL FROM THIS END ONLY.

DANGER AT OUTFEED
Workpiece can suddenly kick back and pull hands into and under cutting tool.

OUTFEED DANGER ZONE SHADED KEEP HANDS AWAY!

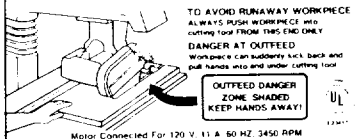

Motor Connected For 120 V, 11 A, 60 HZ, 3450 RPM
For 240 V, 5.5 A, Connect. See Owner's Manual.

DANGER

TO AVOID INJURY DO NOT FEED MATERIAL INTO CUTTING TOOL FROM THIS END

DANGER BEFORE EDGING

Know this tool:

1. Read and Understand all warnings and instructions on saw, in Owner's Manual and with recommended accessories.
2. Properly guard the cutting tool.
3. Provide proper workpiece support.
4. Position the cutting tool behind the fence by moving the arm to the left and clamping the yoke so this label faces the fence or construct an auxiliary fence per Owner's Manual.
5. With power off the switch key removed, turn cutting tool by hand to make sure it does not strike guard, fence or any other saw parts.

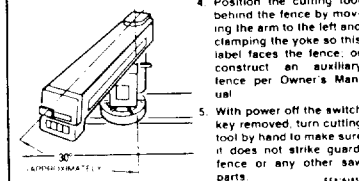

WHEN INSTALLING OR MOVING THE SAW

1. To avoid injury from unexpected carriage travel, lock the rip lock handle before moving the saw.
2. To avoid injury from unexpected saw movement:
 - (a) Bolt the saw to the floor if it tends to slip, walk, or slide during normal operation.
 - (b) When table extensions over 24" wide are added to either side of the saw, make sure you either bolt the saw to the floor or support the outer end of the extension from the floor as appropriate.
3. To avoid injury from unexpected carriage travel adjust leveling feet so the arm tilts slightly downward to the rear so that the carriage will not roll forward due to gravity. Forward drift of the carriage on an improperly leveled saw could cause the blade to lunge forward due to un-

expected contact with the workpiece, fence, table or part of your body.

BEFORE EACH USE

Plan your work.

- To avoid injury from accidental starting, always remove the plug from the outlet, turn the switch off and remove the switch key before removing the guard, changing the cutting tool, changing the setup or making adjustments.
- To avoid injury from blade contact, slips, shocks, thrown pieces, etc., check the saw to make sure that no parts are missing or broken, bent, or have failed in any way, or any electrical component fails to perform properly. Shut off power switch, pull the plug from the outlet and replace damaged, missing and/or failed parts before resuming operation.
- To avoid injury from electrical shock, make sure your fingers do not contact the terminals when installing or removing the plug to or from a live outlet.
- Check the fence for proper workpiece support. To avoid fence breakage which could result in thrown workpieces and blade contact, do not use fences made of particle board or other composite materials - use 3/4" thick lumber long enough to extend in one piece from end to end of the saw table, and tall enough to be at least even with the top of the workpiece. Replace any fence where existing slots in the fence have weakened the fence or can snag the workpiece during ripping operations. Always check table locks to make sure any new fence is held securely (see page 18).
- Choose your cutting tool carefully. Many saw accidents are caused by use of the wrong type blade, dull, badly set, improperly sharpened cutting tools, gum or resin adhering to the cutting tools, and by blade misalignment with the saw fence. Such conditions can cause the material to stick, jam (stall the saw), throw or "kickback" the workpiece at the operator.
- To avoid cutting tool failure and thrown shrapnel (broken pieces of blade), use only blades or other cutting tools marked for operating speeds 3450 rpm or higher. Never use a cutting tool larger in diameter than the diameter for which the saw was designed.
- To avoid jamming of the blade, thrown workpieces, and damage to the blade collars, never use a broken, warped, or unbalanced blade. Do not overtighten arbor nut. Use arbor wrenches to "snug" it securely.
- To avoid injury from accidental blade contact by the workpiece or the operator do not perform layout, assembly, or setup work on the table

while the cutting tool is rotating. The rotating tool could cut and throw anything hitting the blade causing the saw to unexpectedly come forward.

- Use the right guard. To avoid losing control of the workpiece, hitting the cutting tool, or being struck by thrown pieces, never do any cutting unless the proper guard (with all its parts in place) is installed and adjusted properly.
- To avoid injury from thrown pieces, slips, blade contact, or jamming of the workpiece, make sure no play exists between the column and column support or in the carriage and that the arm, yoke, bevel locks/clamps are tight.
- To avoid injury from thrown objects, slips or jamming of the blade due to pinching of the blade by shifting boards:
 - (a) Do not leave a long board unsupported so the spring of the board causes it to twist or rise from the table.
 - (b) Check to be sure that pieces will not fall off the table once they have been cut.
 - (c) Provide support for the workpiece, based on its size and the type of operation to be performed.
 - (d) Never use another person as a substitute for a table extension, or as an additional support for a workpiece to assist in feeding, supporting, or pulling the workpiece.
 - (e) Never cut workpieces placed side to side or stacked on top of each other. The pieces can slide on each other.



- The operation of any power tool can result in foreign objects being thrown into the eyes, which can result in permanent eye damage. Always wear safety goggles complying with ANSI Z87.1 (shown on package). Safety goggles are available at Sears retail catalog stores. Use of goggles or glasses not in compliance with ANSI Z87.1 could result in severe injury from breakage of the eye protection.
- To avoid injury from uncontrollable reaction or thrown objects, never turn the saw "ON" before clearing the table or work surface of all objects (tools, scraps of wood, etc.) except the properly supported workpiece and related feed or support devices for the operation planned.

WHENEVER THE SAW IS RUNNING

- Always keep alert. Do not allow familiarity (gained from frequent use of your saw) to cause a careless mistake. Always remember that a careless fraction

of a second is sufficient to inflict severe, permanent injury.

- If your saw makes an unfamiliar noise or if it vibrates excessively, stop the operation immediately. Do not restart until the source has been located and the problem corrected.
- Do not cycle the motor switch "ON" and "OFF" rapidly, as this might cause the sawblade to loosen. In the event this should ever occur, turn the switch off, allow the sawblade to come to a complete stop, and remove the switch key. To avoid damage to the blade and flange, retighten the arbor nut normally, not excessively.
- Never perform any operation freehand. Injury can occur from blade contact or thrown pieces when the workpiece is torn from the hands. "Freehand" means feeding the sawblade into a workpiece or feeding the workpiece into the sawblade or other cutting tool without using the fence or some other proper device to prevent the workpiece from twisting and binding on the cutting tool during the cutting operation.
- To avoid accidental blade contact, avoid awkward hand positions where a sudden slip causes a hand to move toward the sawblade or other cutting tool. Do not place fingers or hand on the workpiece or table that is in the path of the sawblade.
- To avoid being pulled into the back of the blade before you can let go or react, never reach in back of, or around the cutting tool, with either hand to hold down the workpiece or for any reason.
- To avoid injury from unexpected starting, never attempt to free a stalled sawblade without first turning the saw "OFF" and removing the switch key. If the sawblade is stalled or jammed, shut the saw "OFF", remove the switch key, remove the workpiece, check for looseness in clamps, arm and carriage, check the sawblade squareness to the table surface and to the fence, and check for heel (see page 20). Adjust as indicated.
- To avoid injury from falling parts or from falling into the saw, never climb on or near the saw when its power is "ON". Never leave the saw area when power is "ON", or before the cutting tool has come to a complete stop.
- To avoid unauthorized saw use, remove the switch key and put the key away before leaving the saw area.

BEFORE STARTING A RIPPING TYPE CUT

- To avoid injury from being struck by a thrown workpiece, position the saw so neither you, a helper, or a casual observer is forced to stand in line with the sawblade or workpiece.
- Whenever possible, use the "in-rip" position. (See page 31.) This provides maximum clearance for feeding by hand, push stick, or push block as appropriate.
- To avoid thrown workpieces or being pulled into the saw before you can react, push the workpiece

from the nose side (opposite the sawdust exhaust chute) of the guard. Note the warning on the guard.



- To avoid injury from thrown pieces, slips, or jams, the workpiece must be held down on the table and against the fence. Plan your hand placements to safely feed the workpiece into the cutting tool. Featherboards can also help keep the work against the fence. A featherboard is made of solid lumber per sketch.

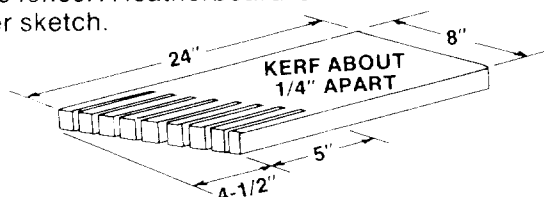

- To avoid accidental blade contact, never position the guard or anti-kickback assembly with the power "ON" or the blade spinning.
- When properly adjusted to just clear the workpiece, the guard nose will help keep the workpiece down on the table. To prevent injury from the workpiece rising from the table, thrown chips from the workpiece or blade, or hand slippage towards the front of the blade, position the nose guard to just clear the workpiece. (See page 26).
- To maximize protection from the rear of the blade and avoid injury from kickbacks, adjust the anti-kickback and spreader devices as instructed. (See page 22 & 26.)
- To avoid injury from kickback, make sure by trial before starting the cut that the anti-kickback pawls will stop the kickback once it has started. Make sure points of pawls are sharp. (See page 26.) Warning: Use extra care for non-thru cuts because the anti-kickback pawls cannot always grab the irregular surface created by the operation.

INSPECT YOUR WORKPIECE

- To keep the sawblade from rising up on top of the workpiece and throwing it back at the operator, when sawing 1/4" or thinner materials, follow all normal ripping procedures except set sawblade into the table top at least 1/8".
- To avoid kickback, use extra care when ripping wood that has a twisted grain or is twisted or bowed - it may rock on the table and/or pinch the sawblade. If the workpiece cannot be made stable against the fence and table top, do not cut it with a radial arm saw.
- To avoid blade contact and/or kickback, use a push stick when ripping short (10 to 12 inches long) or narrow (2 to 6-1/2 inches wide) workpieces. Use a push block as illustrated on page 30 for pieces 3/8 to 2 inches wide or, wherever possible, place the wider section of the board between the fence and the blade.

- To avoid kickbacks never feed a workpiece through the saw with another piece (butting second piece against trailing end of piece being cut) even if of the same thickness.
- To keep control of your workpiece, never rip work shorter than the blade diameter.
- For rip or rip-type cuts, the trailing end of the workpiece to which a push stick or push board is applied must be square (perpendicular to the fence and table top) so that feed pressure applied to the workpiece by the push stick or push block will not cause the workpiece to come away from the fence or rise from the table and possibly cause a kickback.
- Plastic and composition (like particle board) materials may be cut on your saw. However, since these are often quite hard and slippery, the anti-kickback pawls may not stop a kickback. To get best performance, rip with the finished side down (next to the table) and the roughest side up, and be especially attentive to follow proper set up and cutting procedures.

WHILE DOING A RIP TYPE OPERATION

- Never reach around the blade to the outfeed side to touch the portion of workpiece beyond the blade until the whole workpiece has been pushed beyond and clear of the blade. Your touch could cause a kickback which could strike someone or pull your hand into the rear (outfeed side) of the blade before you can let go or react.
- Position your body at the nose (in-feed) side of the guard. Start and complete the cut from that same side. This will require added table support for long or wide workpieces that extend beyond the length or width of the saw table to prevent workpiece from being thrown as it falls from the table.
- Never apply the feed force to the section of the workpiece that will become the cutoff (free) piece. Feed force when ripping must always be applied between the sawblade and the fence so that the slot cut by the blade (kerf) will not be pinched shut on the blade causing a kickback. Never touch the piece that has been cut off until the blade has come to a complete stop.
- Keep pushing the section of the workpiece between the blade and the fence until the piece has been pushed completely past the blade, so the blade will not grab the piece and throw it back at the operator.

BEFORE DOING A CROSSCUT TYPE CUT

- To avoid blade contact, do not perform any operation that requires the cutting tool to extend beyond the edges of the table used for supporting the workpiece.
- To maximize protection from accidental blade contact and reduce risk of jamming objects into the guard, place guard in a horizontal position and adjust anti-kickback pawls to just clear the top of the fence or the workpiece, whichever is higher. The anti-kickback pawl assembly will

provide additional guarding from contact with the front of the blade.

- To prevent the cutting tool from grabbing the table or workpiece and being propelled toward you, never lower a revolving cutting tool into the table or a workpiece without first locking the rip lock handle and clamping the workpiece in place. Release the handle only after having firmly grasped the carriage handle.
- To avoid blade contact or injury from a thrown cut off piece, never use a length stop on the cut off end or edge of the workpiece. Never hang onto or touch the cut off piece of the workpiece while the power is "ON" and/or the sawblade is rotating. To prevent pinching that could cause the piece to be thrown, the cut off piece must never be confined, pushed, or grabbed while the blade is spinning.

INSPECT YOUR WORKPIECE

- To avoid injury from thrown objects, slips or jamming of the blade, make sure the workpiece will fit the supports (fence, table, fixtures or jigs) so it will not twist, rock or otherwise bind on the cutting tool. Make sure there is no sawdust or other foreign material between the workpiece and its support.

WHILE DOING A CROSSCUT TYPE CUT

- Always start with the carriage in the full rear position behind the fence before turning the saw on.
- Never push the carriage and blade backwards into the work to do a crosscutting type operation. The cutting tool can throw the work over the fence, striking someone or causing you to fall into the blade.

- Always return the carriage to the full rearward position behind the fence at the completion of each crosscut type operation. Never remove your hand from the yoke handle unless the carriage is in this position. Otherwise, the cutting tool may climb up on the workpiece and be propelled toward you.

BEFORE USING ACCESSORIES

- To avoid injury from unanticipated hazards, use only recommended accessories as listed on page 43.
- The use of grinding wheels, abrasive or cut off wheels, or wire wheels, can be dangerous and are not recommended. Such devices can break explosively and throw shrapnel, causing severe injury.
- The sawblade, dado, or other cutting tool must be removed from the saw arbor before using the accessory shaft. Never operate the saw with cutting tools (including sanding accessories or buffing) installed on both ends of the saw arbor to avoid being pulled into moving parts by hair, threads, clothing, etc. Make sure the unused arbor is always covered by a guard, the arm, or the screw cap.
- Using a drill chuck. To avoid injury from sudden bending or breaking of a drill bit, do not install or use twist drills longer than 7" in length or extending more than 6" beyond the chuck jaws. Do not install or use any reduced shank drill except the spade type (1" diameter or smaller). Use for drilling wood or plastic only - bit speed cannot be properly adjusted for other materials. Do not use twist drills larger than 1/2" in diameter.

glossary of terms for woodworking

Anti-Kickback Pawls (AKB)

Device which, when properly adjusted, is designed to stop the workpiece from being kicked back at the operator during ripping operations. See illustrations on pages 22 & 26.

Arbor

The shaft on which a cutting tool is mounted.

Crosscut

A cutting or shaping operation made across the width of the workpiece. See illustrations on pages 28 & 29.

Dado

A non-through cut which produces a square sided notch or trough in the workpiece.

Featherboard

A device which can assist in guiding workpieces during rip type operations.

Freehand

Performing a cut without the use of fence (guide), hold down or other proper device to prevent the workpiece from twisting during the cutting operation. Twisting of the workpiece can cause it to be thrown or kicked back by a radial saw.

Gum

A sticky, sap based residue from wood products.

Heel

Misalignment of the blade. See page 20 & 21.

In-Rip

Positioning the blade parallel to the fence with the motor toward the front of the saw. See illustration on page 31.

Kerf

The amount of material removed by the blade in a through cut or the slot produced by the blade in a non-through or partial cut.

Kickback

An uncontrolled grabbing and throwing of the workpiece back toward the operator during a rip type operation.

Leading End

The end of the workpiece which, during a rip type operation, is pushed into the cutting tool first.

Molding

A non-through cut which produces a special shape in the workpiece used for joining or decoration.

Outrip

Positioning the blade parallel to the fence with the motor toward the rear of the saw producing maximum ripping capacity. See illustration on page 31.

Push Stick

A device used to feed the workpiece through the saw during narrow ripping type operations so the operator's hands are kept well away from the blade. See page 30.

Push Block

A device used for ripping type operations too narrow to allow use of a push stick. See page 30.

Rabbet

A notch in the edge of a workpiece.

Resin

A sticky, sap base substance that has hardened.

Ripping

A cutting operation along the length of the workpiece.

Revolutions Per Minute (RPM)

The number of turns completed by a spinning object in one minute.

Sawblade Path

The area of the workpiece or table top directly in line with either the travel of the blade or the part of the workpiece which will be, or has been, cut by the blade.

Set

The distance that the tip of the sawblade tooth is bent (or set) outward from the face of the blade.

Throw-Back

Throwing of small pieces in a manner similar to a kickback.

Thru-Sawing

Any cutting operation where the blade extends completely through the thickness of the workpiece.

Trailing End

The workpiece end last cut by the blade in a ripping operation.

Workpiece

The item on which the cutting operation is being performed. The surfaces of a workpiece are commonly referred to as faces, ends, and edges.

electrical connections

POWER SUPPLY

1. Motor Specifications

The A-C motor used in this saw is a capacitor-start, non-reversible type having the following specifications:

Rated H.P.	1.5
Maximum Developed H.P.	2.5
Voltage	120
Amperes	11
Hertz (cycles)	60
Phase	Single
RPM	3450
Rotation of Blade Arbor	Clockwise

WARNING: TO AVOID ELECTRICAL HAZARDS, FIRE HAZARDS, OR DAMAGE TO THE TOOL, USE PROPER CIRCUIT PROTECTION. YOUR SAW IS WIRED AT THE FACTORY FOR 120V OPERATION. CONNECT TO A 120V, 15-AMP, BRANCH CIRCUIT AND USE A 15-AMP, TIME DELAY FUSE OR CIRCUIT BREAKER.

IF NOT PROPERLY GROUNDED THIS POWER TOOL CAN CAUSE ELECTRICAL SHOCK - PARTICULARLY WHEN USED IN DAMP LOCATIONS IN PROXIMITY TO PLUMBING. IF AN ELECTRICAL SHOCK OCCURS THERE IS ALSO THE POTENTIAL OF A SECONDARY HAZARD SUCH AS YOUR HANDS CONTACTING THE SAWBLADE. NOT ALL OUTLETS ARE PROPERLY GROUNDED. TO AVOID SHOCK OR FIRE, IF POWER CORD IS WORN OR CUT, OR DAMAGED IN ANY WAY, HAVE IT REPLACED IMMEDIATELY.

If you are not sure that your outlet is properly grounded, have it checked by a qualified electrician.

If your unit is for use on less than 150 volts it has a plug that looks like below.

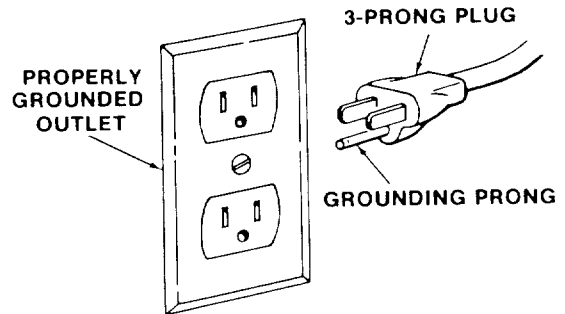

This power tool is equipped with a 3-conductor cord and grounding type plug which has a grounding prong, listed by Underwriters' Laboratories. The ground conductor has a green jacket and is attached to the tool housing at one end and to the ground prong in the attachment plug at the other end.

This plug requires a mating 3-conductor grounded type outlet as shown above.

WARNING: TO MAINTAIN PROPER TOOL GROUNDING WHENEVER THE OUTLET YOU ARE PLANNING TO USE FOR THIS POWER TOOL IS OF THE TWO PRONG TYPE, DO NOT REMOVE OR ALTER THE GROUNDING PRONG IN ANY MANNER. USE AN ADAPTER AS SHOWN AND ALWAYS CONNECT THE GROUNDING PRONG TO KNOWN GROUND.

It is recommended that you have a qualified electrician replace the two prong outlet with a properly grounded three prong outlet.

An adapter as shown below is available for connecting plug to 2-prong receptacles. The green grounding lead extending from the adapter must be connected to a permanent ground such as to a properly grounded outlet box.

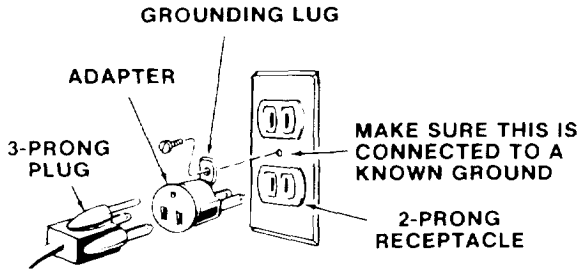

WARNING: THE ADAPTER ILLUSTRATED IS FOR USE ONLY IF YOU ALREADY HAVE A PROPERLY GROUNDED 2-PRONG RECEPTACLE.

MOTOR SAFETY PROTECTION

CAUTION: TO AVOID MOTOR DAMAGE THIS MOTOR SHOULD BE BLOWN OUT OR VACUUMED FREQUENTLY TO PREVENT SAWDUST BUILD-UP WHICH WILL INTERFERE WITH NORMAL MOTOR VENTILATION.

1. This tool should be connected to a 120V, 15 Amp branch circuit with a 15 Amp time delay fuse or circuit breaker. Failure to use the proper size fuse can result in damage to the motor.
2. If the motor fails to start, turn the power switch to the "OFF" position immediately. UNPLUG THE TOOL. Check the saw blade to insure that it turns freely and that its teeth are not wedged into the table top. After the blade has been freed, try to start the motor again. If, at this point, the motor still fails to start, refer to the "Motor Trouble-Shooting Chart."
3. If the motor should suddenly stall while cutting wood, the power switch should be turned off, the tool unplugged and the blade freed from the wood. The motor may now be restarted and the cut finished.

4. Frequent "blowing" of fuses or tripping of circuit breakers may result if:

- (a) **MOTOR IS OVERLOADED** - Overloading can occur if you feed too rapidly or if saw is misaligned so that the blade heels (pg. 19,20).
- (b) **MOTOR CIRCUIT IS FUSED DIFFERENTLY FROM RECOMMENDATIONS** - Always follow instructions for the proper fuse/breaker. Do not use a fuse/breaker of greater capacity without consulting a qualified electrician.
- (c) **LOW VOLTAGE** - Although the motor is designed for operation on the voltage and frequency specified on motor nameplate, normal loads will be handled safely on voltages not more than 10% above or below the nameplate voltage. Heavy loads, however, require that voltage at motor terminals equals the voltage specified on nameplate.

5. Most motor troubles may be traced to loose or incorrect connections, overloading, reduced input voltage (such as small size wire in the supply circuit) or to overly long supply circuit wire. Always check the connections, the load and the supply circuit whenever motor fails to perform satisfactorily. Check wire sizes and length with the Wire Size Chart below.

WIRE SIZES

The use of any extension cord will cause some loss of power. To keep this to a minimum and to prevent over-heating and motor burn-out, use the table below to determine the minimum wire size (A.W.G.) extension cord. Use only 3 wire extension cords which have 3 prong grounding type plugs and 3-pole receptacles which accept the tools plug.

CAUTION: For circuits that are farther away from electrical service box, the wire size must be increased proportionately in order to deliver ample voltage to the saw motor.

Length of the Conductor	Wire Sizes Required (American Wire Gage Number)	
	240V Lines	120V Lines
0 - 50 Feet	No. 16	No. 14
50 - 100 Feet	No. 14	No. 12
Over 100 Feet	No. 12	No. 8

contents

	Page		Page
Guarantee	2	Location and Function of Controls	23
General Safety Instructions for Power Tools	2	Basic Saw Operations	27
Additional Safety Instructions for Radial Saws ..	3	Adjustments to Compensate for Wear	33
Glossary of Terms for Woodworking	6	Trouble Shooting	37
Electrical Connections	7	Maintenance and Lubrication	42
Assembly and Alignment	9	Recommended Accessories.....	43
Unpacking and Preassembly.....	10	Repair Parts	44
Alignment Procedure.....	16		

assembly and alignment

TOOLS NEEDED

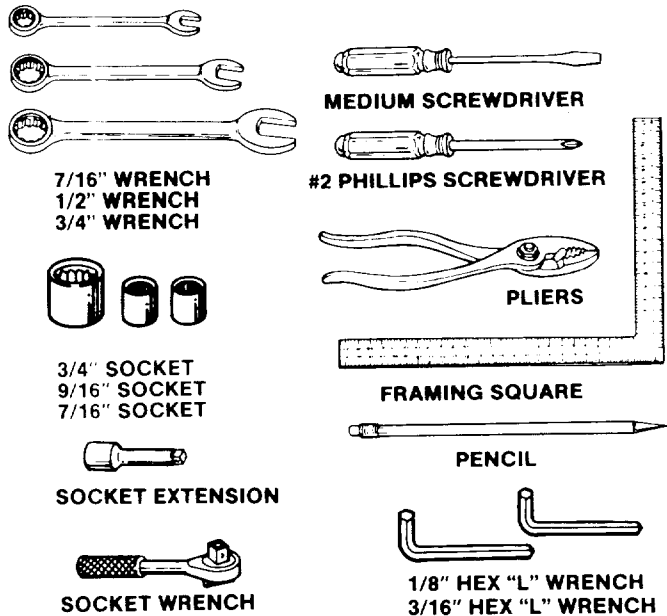

FRAMING SQUARE MUST BE TRUE.

Check its accuracy as illustrated below.

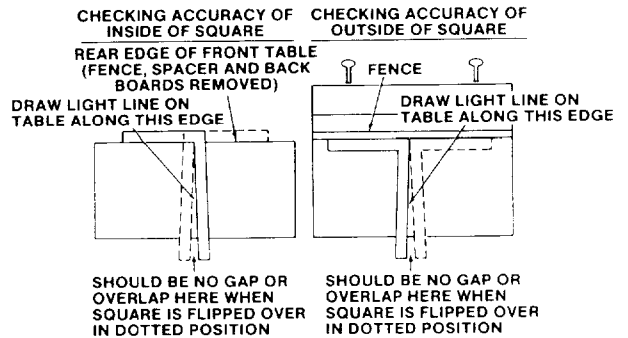

unpacking and preassembly

WARNING: TO AVOID INJURY FROM UNEXPECTED STARTING OR ELECTRICAL SHOCK, DO NOT PLUG THE POWER CORD INTO A SOURCE OF POWER UNTIL ALL ASSEMBLY AND ALIGNMENT STEPS ARE COMPLETE. THIS CORD MUST REMAIN UNPLUGGED WHENEVER YOU ARE WORKING ON THE SAW.

Model 113.198310 Radial Saw is shipped complete in one box.

1. Unpacking and Checking Contents

(a) Separate all "loose parts from packaging materials and check each item with "Table of Loose Parts" to make sure all items are accounted for, before discarding any packing material.

WARNING: IF ANY PARTS ARE MISSING, DO NOT ATTEMPT TO ASSEMBLE RADIAL ARM SAW, PLUG IN THE POWER CORD, OR TURN THE SWITCH ON UNTIL THE MISSING PARTS ARE OBTAINED AND ARE INSTALLED CORRECTLY.

LOOSE PARTS LIST FOR MODEL 113.198310

Item	Description	Qty.
A	Basic Saw Assembly	1
B	Owners Manual	1
C	Fence, Rip	1
D	Table, Rear	1
E	Table, Spacer	1
F	Cap Trim, L.H.	1
G	Cabinet Assembly	1
H	Handwheel Assembly	1
I	Trim Ledge	1
J	Cap Trim, R.H.	1
K	Arbor Wrench	1
L	Shaft Wrench	1

Item	Description	Qty.
M	Bag of Loose Parts #507495	1
Containing the Following Items:		
A	Foot Leveling	4
B	Nut Hex Jam 1/2-13	8
C	Screw, Truss Hd. 1/4-20 x 1/2	48
D	Lockwasher Ext. 1/4	48
E	Nut Hex 1/4-20	48
F	Screw, Pan Hd. Ty "BT" 1/4 x 1/2	8
G	Screw, Pan Hd. Ty B #10 x 1	6

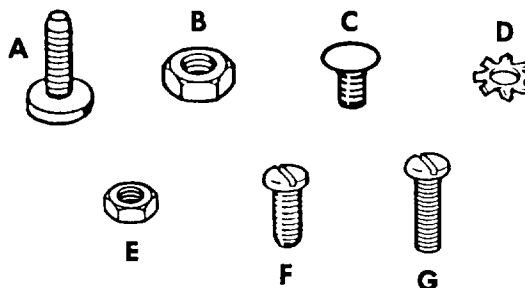

Item	Description	Qty.
N	Bag of Loose Parts #507497	1
Containing the Following Items:		
A	Pad Guard	1
B	Indicator Rip	2
C	Indicator Bevel	1
D	Cap Motor Support	1
E	Plug Plastic	4
F	Screw Pan Hd. 10-32 x 1/2	1
G	Lockwasher Ext. #10	1
H	Cover	2
I	Switch Key	1

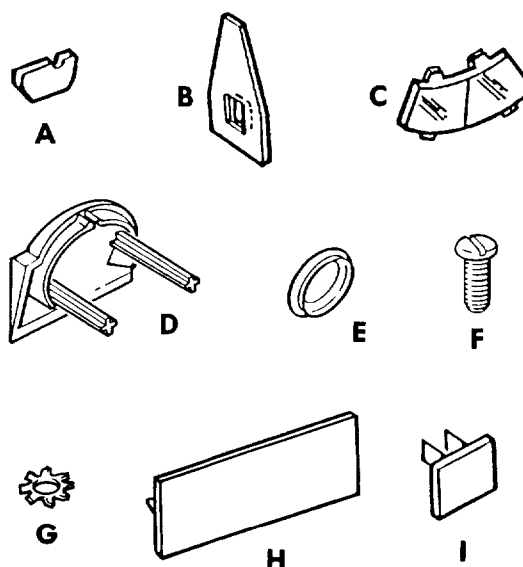
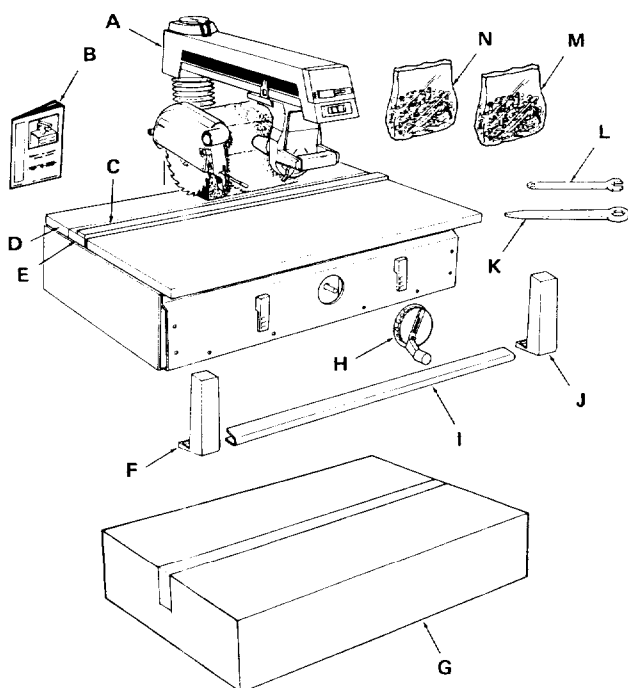

NOTE: Loose Parts Bag and Assembly Numbers refer to three digits, underlined in example below, or the I.D. Number printed on each bag or carton.

X04507488H000

44" CABINET ASSEMBLY FOR MODEL NO. 113.198310

ASSEMBLE CABINET BEFORE MOUNTING SAW

1. Separate all "loose" parts from packing materials and check each item with "Parts List" to make sure all items are accounted for before discarding any packing material.

44" CABINET ASSEMBLY FOR MODEL NO. 113.198310

A	Right Side Panel	1
B	Left Side Panel	1
C	Lower Shelf	1
D	Under Support	1
E	Skirt	2
F	Shelf Stiffener	1
G	Corner Brackets	4
H	Spacer	2
I	Shelf Stiffener Rear	1

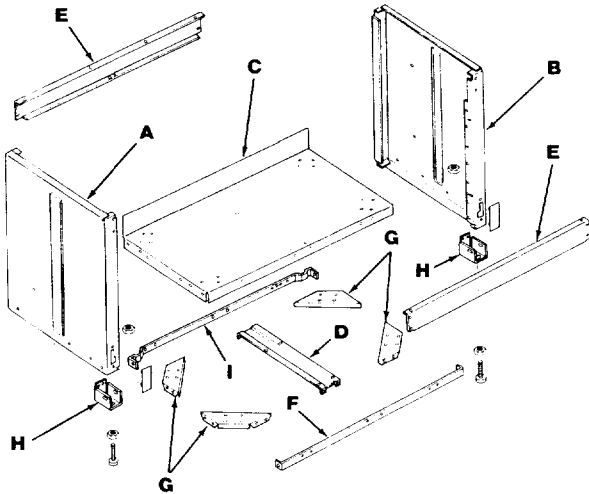

WARNING: IF ANY PARTS ARE MISSING, DO NOT ATTEMPT TO ASSEMBLE RADIAL ARM SAW, PLUG IN THE POWER CORD, OR TURN THE SWITCH ON UNTIL THE MISSING PARTS ARE OBTAINED AND ARE INSTALLED CORRECTLY.

2. After layout of stand parts, take the bottom shelf and turn upside down on floor. Small front flange should be pointing upward.
3. Place one shelf stiffener against front flange of shelf as shown.

4. Place the under support on the shelf. Locate two (2) 1/4-20 x 1/2 truss head bolts, lockwashers and hex nuts from loose parts bag #495. Attach the supports to the shelf in holes as illustrated and tighten nuts with 7/16" wrench or socket.

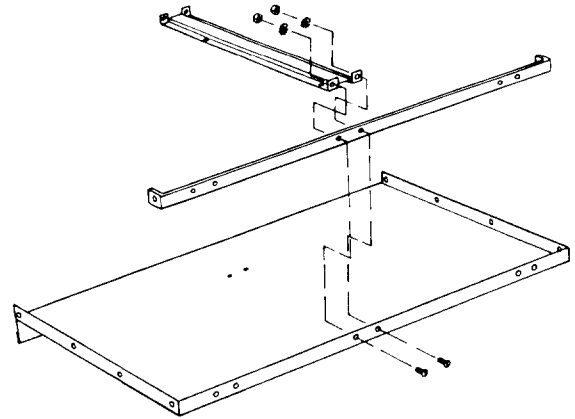

Assembly and Alignment

5. Assemble the under support to the lower shelf with four (4) 1/4-20 x 1/2 truss head bolts, lockwashers and hex nuts. Tighten securely with 7/16" wrench or socket.

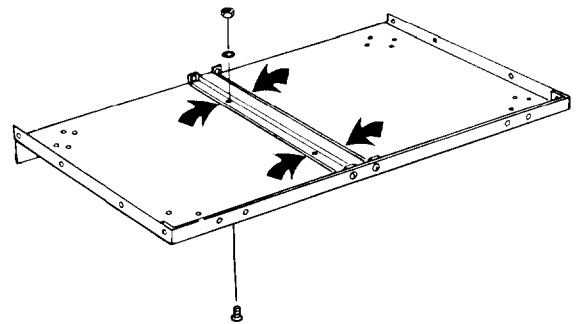

6. Attach the second shelf stiffener to the under support. Use two (2) 1/4-20 x 1/2 truss head bolts, lockwashers, and hex nuts to fasten to the under support with 7/16" wrench or socket.

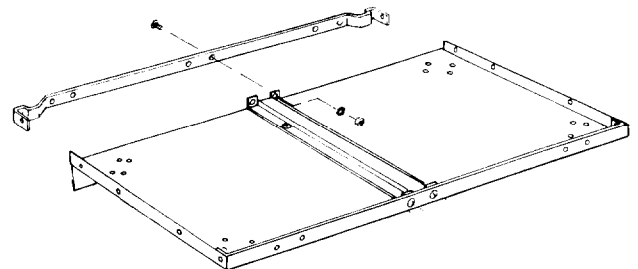

7. Locate the four (4) corner brackets and use eight (8) 1/4-20 x 1/2 truss head bolts, lockwashers and hex nuts to mount the corner brackets to the shelf AS ILLUSTRATED. Tighten the nuts with a 7/16" wrench or socket.

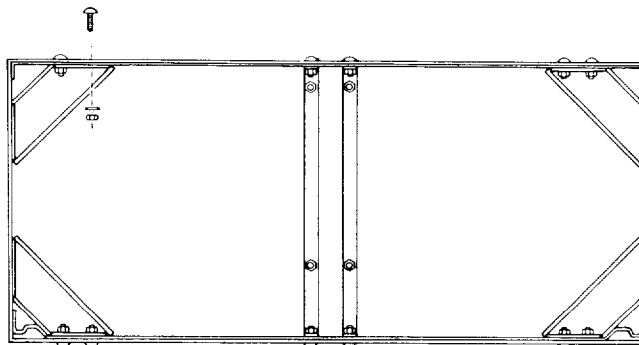

8. Locate the right and left side panels and eight (8) 1/4-20 x 1/2 truss head bolts, lockwashers and hex nuts to attach side panels to shelf. Mount the bolts through the four holes as illustrated and tighten with 7/16 wrench or socket. To assemble, lay the side panel on its backside and stand the shelf up as illustrated.

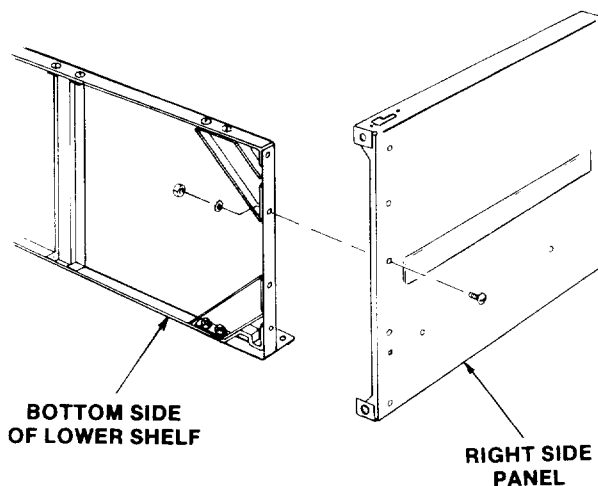

9. Locate the two (2) skirts and the eight (8) 1/4-20 x 1/2 truss head bolts, lockwashers and hex nuts to attach them to the top of the side panels. Attach one to the front and one to the rear of the stand as illustrated and hand tighten nuts.

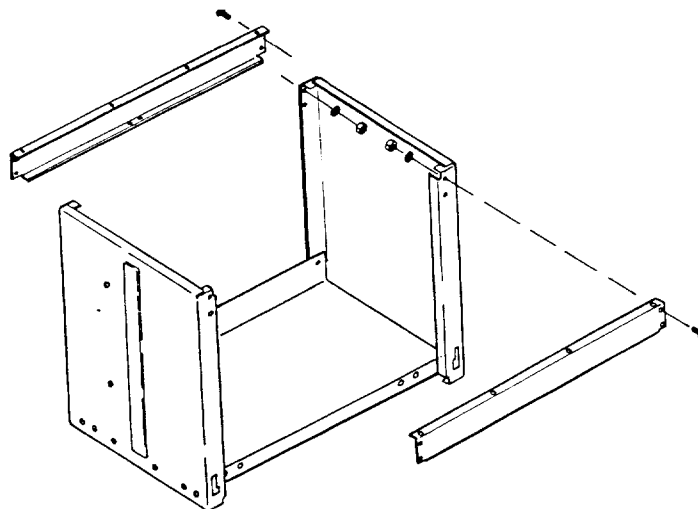

10. Secure rear of lower shelf to right side and left side panels using two (2) 1/4-20 x 1/2 truss head bolts, lockwashers and hex nuts. Hand tighten nuts only at this time.

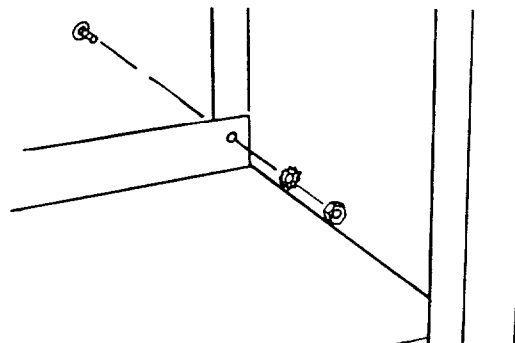

11. Locate the right and left side spacers, the six (6) 1/4-20 x 1/2 truss head bolts, lockwashers, and hex nuts. Position the spacer inside the right and left side panels and fasten in the three holes as illustrated. Hand tighten nuts.
12. Locate the two (2) covers and attach to openings in the right and left side panels as illustrated.

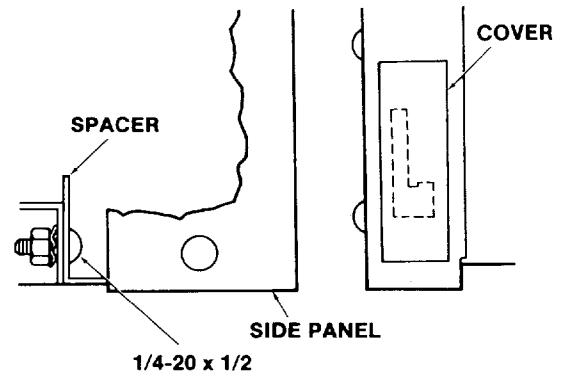

CHECKING CABINET FOR SQUARENESS

TOOLS NEEDED: Framing square, 3/4" wrench and 7/16" wrench or socket.

1. With cabinet on back side place a square on lower shelf next to right side panel. Adjust stand so both right side panel and lower shelf touch square (as illustrated). Then tighten nut holding rear of shelf to side panel and right side spacer to front of lower shelf. Repeat procedure for left side.

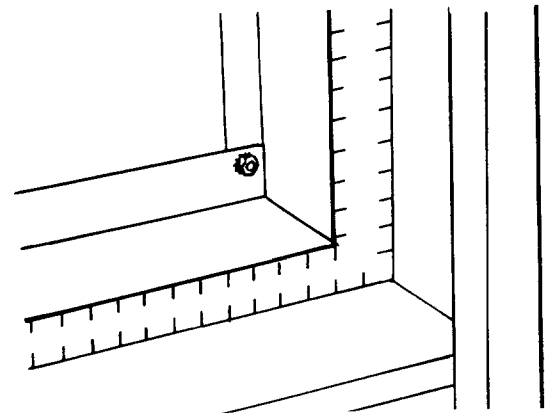

2. Place square at top side of cabinet and adjust stand so square touches both skirt and side panel (as illustrated). Then tighten right side of front and rear skirts to side panel. Repeat procedure for left side.

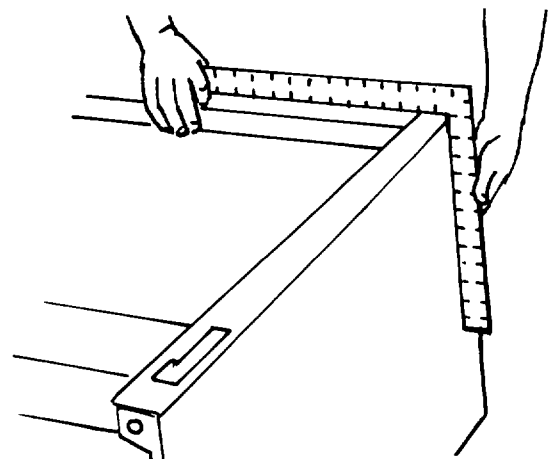

3. Locate four (4) leveling and eight (8) 1/2-13 hex nuts. Attach the leveling feet to bottom of side panels in front and rear as illustrated. Hand tighten hex nuts.

WARNING: TO AVOID INJURY FROM UNEXPECTED SAW OR WORK MOVEMENT, LEVELING FEET MUST BE ADJUSTED SO THAT SAW DOES NOT ROCK. TO AVOID UNEXPECTED CARRIAGE MOVEMENT, ADJUST LEVELING FEET SO THAT THE ARM SLOPES SLIGHTLY DOWNWARD TO THE REAR.

4. To adjust leveling feet so the saw will set properly:
 - a. Move saw to desired location.
 - b. With 3/4" wrench loosen bottom nut.
 - c. Back off top nut by hand.
 - d. Raise or lower foot by adjusting bottom nut using 3/4" wrench.
 - e. Snug top nut against inside of leg by hand.
 - f. Adjust all four feet as necessary, then tighten all four bottom nuts using a 3/4" wrench.

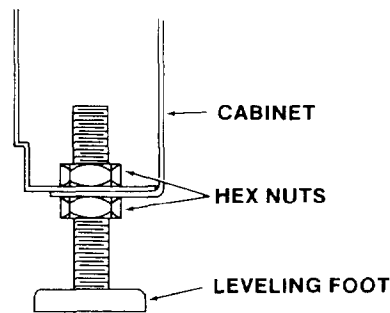

MOUNTING SAW

1. From loose parts bag #495, find the following hardware:
 - 8 - Truss Head Bolts 1/4-20 x 1/2
 - 8 - Lockwashers External 1/4
 - 8 - Hex Nuts 1/4-20
2. Place saw on cabinet so that holes in bottom of saw line up with holes in top of cabinet.
3. Install bolts, lockwashers, and nuts as shown. Tighten securely using a 7/16" wrench or socket.

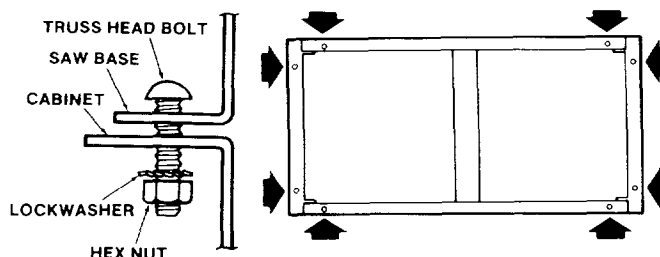

NOTE: It may be necessary to loosen the bolts holding the skirt to the side panel of the cabinet if the holes do not line up. Once mounting bolt is in place retighten cabinet bolts securely.

ATTACHING TRIM CAPS & TRIM LEDGE

1. Locate the two (2) trim caps, the trim ledge, the six (6) type "B" #10 x 1 screws and eight (8) type BT 1/4 x 1/2 screws.
2. Place the trim ledge against the bottom of the base using four (4) type "B" metal screws, secure the trim ledge to the base from below using a phillips screwdriver.

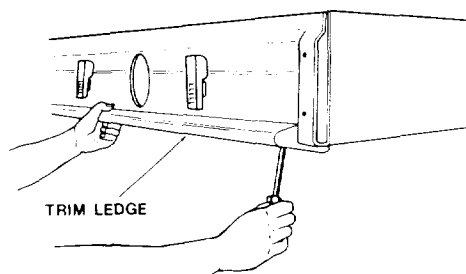

3. Then reach through the base from behind the front table board and secure the trim ledge with four (4) type "BT" screws using a phillips screwdriver.

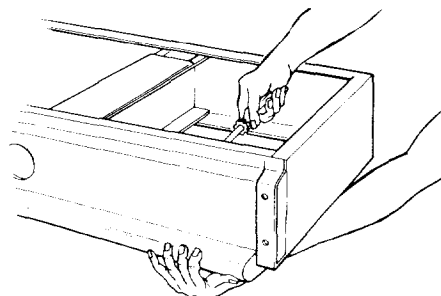

4. Position the trim caps in place and hold in place with type B metal screw from the bottom side.
5. Then reach through the base from behind the front table board and secure the trim cap with two (2) type "BT" screws using a phillips screwdriver. Repeat procedure for other side.

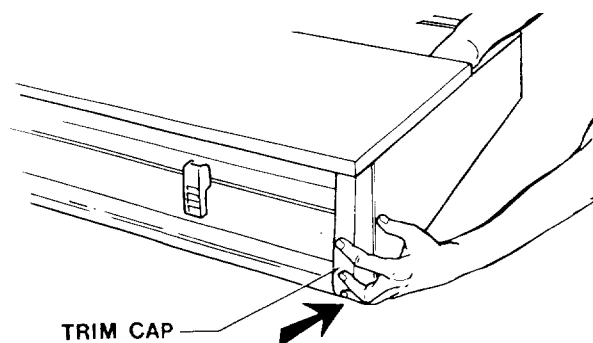

ATTACH ELEVATION HANDWHEEL

1. From loose parts bag #497, find one (1) screw 10-32 x 1/2 and one (1) external lockwasher. Install handwheel to front of base as illustrated.

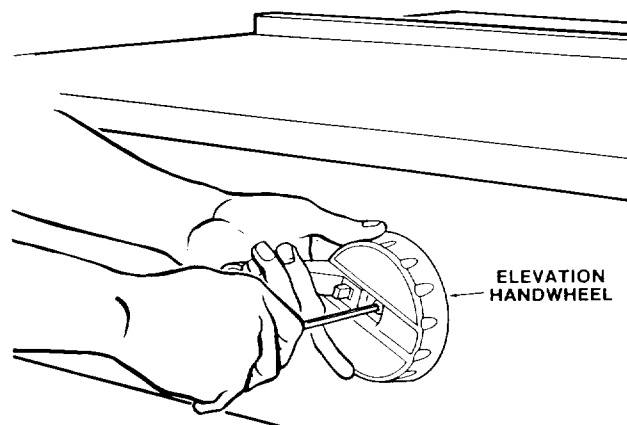

Assembly and Alignment

MOUNTING MOTOR

1. Remove the blade guard. Locate the arbor wrenches and remove the blade.

CAUTION: Do not attempt to mount the motor until the blade guard and blade have been removed.

2. Elevate the arm approximately 2 inches to remove shipping pad.
3. Using a 3/4" socket remove 1/2-13 lock nut and 1/2" flat washer from motor pivot support.
4. Slide motor on motor pivot support until motor is firmly seated on support as illustrated.
5. Re-install the flat washer and lock nut and tighten until snug with 3/4" socket.

WARNING: DO NOT OVER TIGHTEN LOCKNUT. To insure proper function of the bevel lock, move the bevel lock handle while tightening the locknut. Adjust according to Step 6.

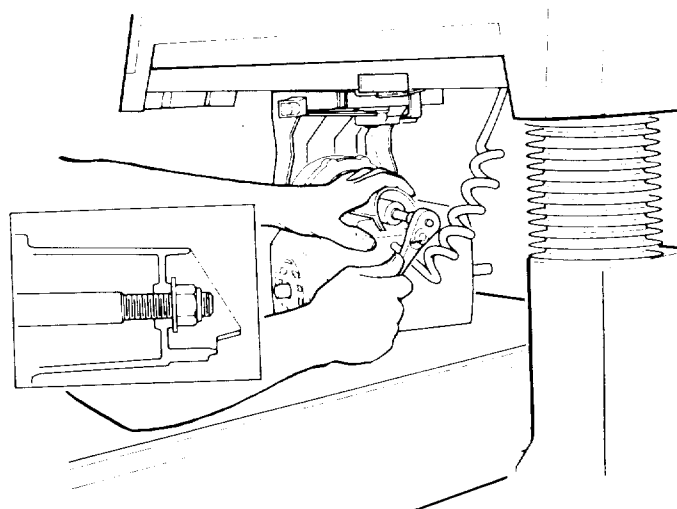

6. Push bevel lock handle to left side to lock.

NOTE: Bevel lock handle should not contact extreme left side of yoke when in locked position. If bevel lock handle is permitted to contact yoke the following adjustment is required.

- a. Unlock bevel lock handle and tighten motor locknut. Recheck bevel lock handle position (see illustration).
- b. Repeat adjustment if necessary. Do not over tighten or motor will not index.

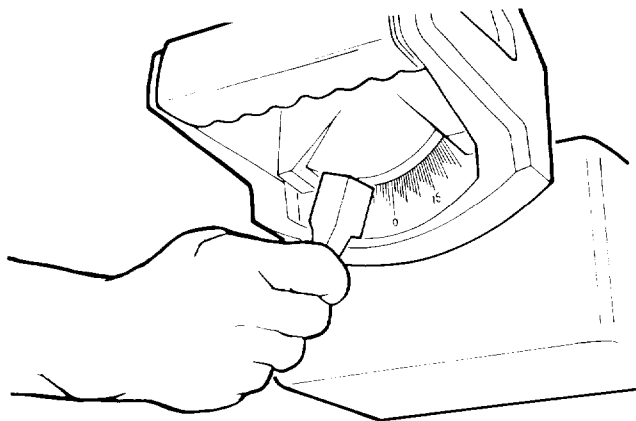

ALIGNMENT PROCEDURE

IMPORTANT: In order to obtain maximum cutting accuracy and safety, the following six steps must be carefully followed. Become thoroughly familiar with these steps so that you can always maintain your saw in proper alignment. The accuracy of each adjustment is always dependent upon the accuracy of the preceding adjustment.

Be sure to align the saw in the exact sequence described to insure proper alignment and cutting accuracy.

After following the 6 step assembly and alignment procedure and the Basic Saw operation section refer to Trouble Shooting section if any difficulty is experienced when performing any sawing operation.

STEP ONE

Adjusting Column Tube in Column Support

1. Elevate and then lower the arm.
 - (a) If the column binds and elevation is difficult, loosen the four (4) bolts, with 9/16 socket and extension, located through the holes in the rear column support cover until movement is smooth but firm.
 - (b) If column moves front to rear within the column support, tighten the four (4) bolts, with a 9/16 socket and extension, located through holes in rear column support cover until movement disappears. Elevation should be smooth and firm. Recheck adjustments, repeat steps (a) and (b) if necessary.
2. Locate the four (4) plastic hole caps in loose parts bag #497. After all adjustments are made to the column support insert the plastic caps in all four holes in rear column support cover.

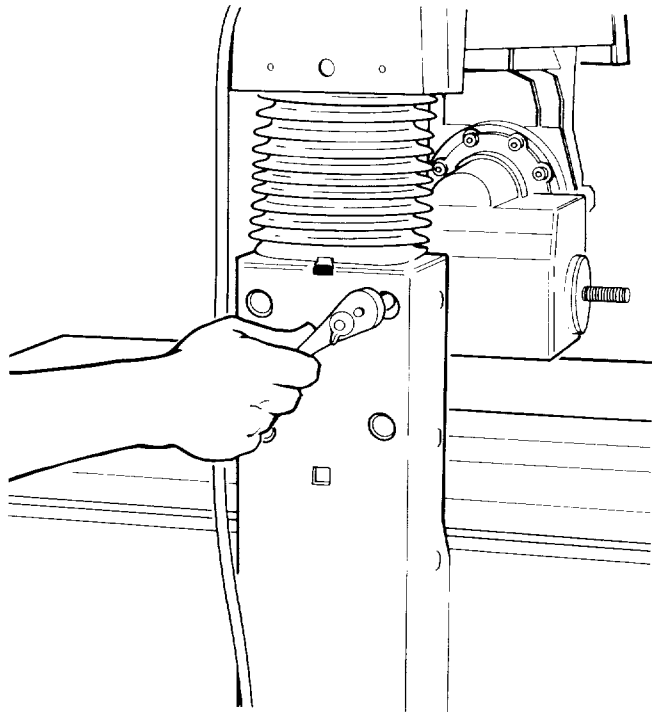

STEP TWO

NOTE: The following adjustment, performed properly, will result in the work table being flat and parallel to the arm. This helps insure the blade will cut the same depth along the entire crosscut travel.

LEVELING FRONT WORK TABLE

1. Loosen the three (3) leveling screws located in the center of the table with a 1/8" hex 'L' wrench.
2. Check the five (5) mounting screws to make sure they are **snug**. Do not over tighten.
3. Push the bevel lock handle to the right to release the motor. Index the motor with the saw blade end of the motor shaft down and lock bevel lock handle to the left.
4. Slide the carriage so the motor shaft is in the center of front table board.
5. Unlock the miter lock handle in the unindex position as shown, and position the arm to the left.

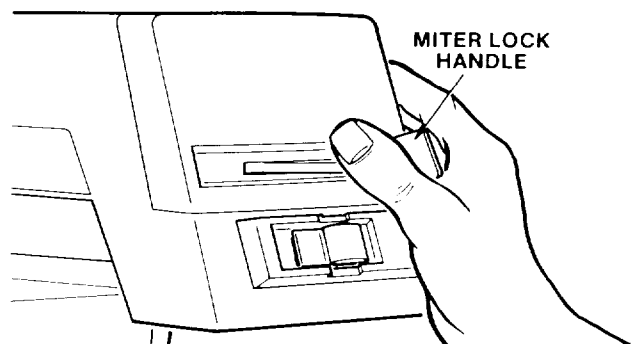
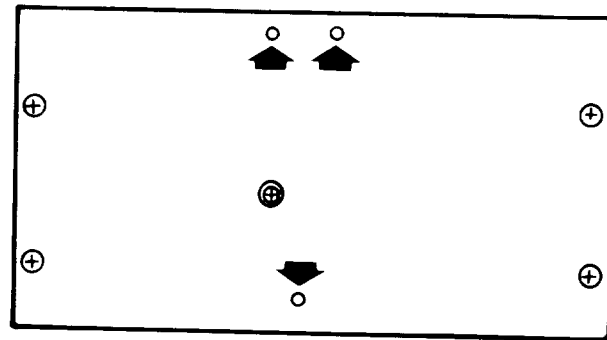

6. Lay the arbor wrench on the work table under the motor shaft. Carefully lower the arm with the elevation handle until the motor shaft is just touching the arbor wrench. The wrench should slide back and forth with only slight contact with motor shaft.

NOTE: When moving the arm from the left side to the right it is necessary to move the motor along the arm to check the front table at several points from front to back.

7. Starting from the left side of the front table board, move the Radial Arm to the right checking the table with the arbor wrench to determine the lowest spot in the table. Once the lowest spot in the table is determined, you can begin to level the table.

NOTE: For safety reasons, stops have been provided to prevent 360° rotation of the radial arm.

8. Position the arm over the lowest spot in the table and repeat Step 6.

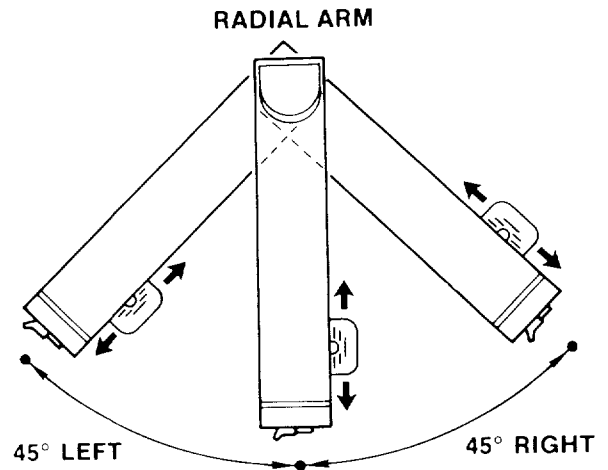
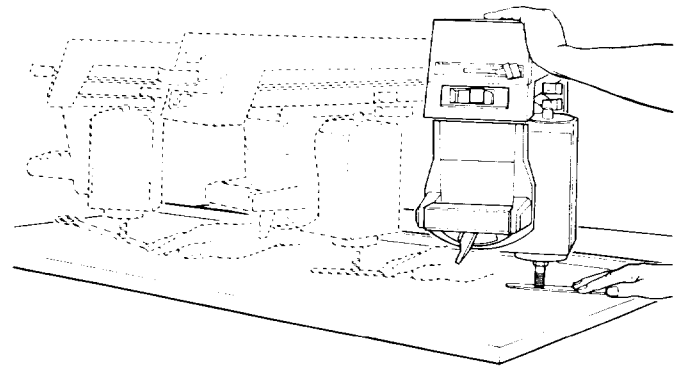

9. Tighten the mounting screws located at the high spots in the table with a Phillips screwdriver. Then recheck the entire table. Make sure center leveling hex screws are loose.

NOTE: Do not change this elevation setting until the entire work table has been adjusted.

10. Lay the rear table board on edge across the front table to serve as a straightedge to determine whether the front table board is high or low at its center.

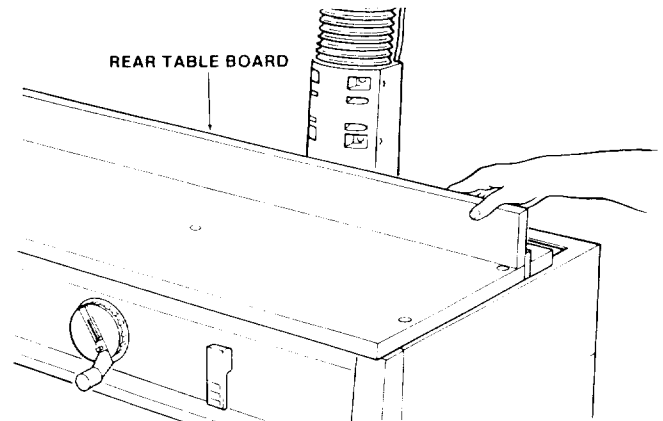

11. If the front table is high at center, first tighten the center hold down screw until table is level - then tighten the three (3) leveling screws until those screws are tight. If table is low at center, first loosen the center holddown screw, then tighten the three (3) leveling screws until table is level. Retighten the center holddown screw. Recheck table to make sure it is level.

12. Position the rip (guide) fence, spacer board and rear table board behind the front table board, and push front table lock handles down as shown.

13. Return motor to vertical position.

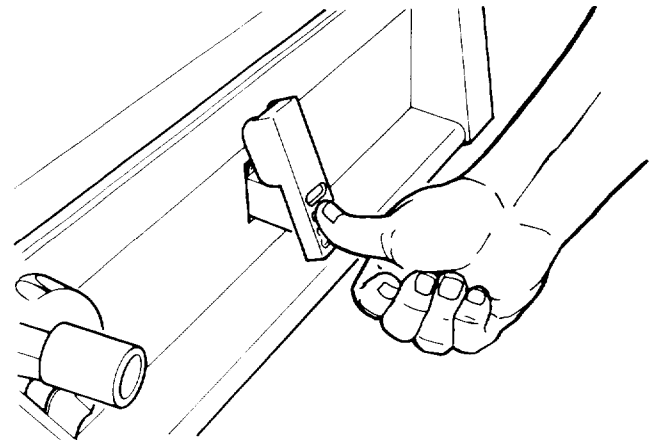

Adjusting front table lock handles

WARNING: TO AVOID SUDDEN SLIPPAGE, BREAKAGE, OR THROWING OF PARTS, FRONT TABLE LOCK HANDLE MUST LOCK TABLE BOARDS AND RIP FENCE SECURELY IN PLACE.

1. To adjust the table board clamps check by pulling up on rip fence. There should be enough pressure to keep the rip fence from pulling up. To adjust the pressure on the clamp:
 - a. Lift front table lock handles up to release pressure on boards.
 - b. Loosen the two eccentric spacer clamps located at the rear of the table top with a 7/16" wrench or socket.
 - c. Rotate the spacer toward the rear table board. Tighten spacer with 7/16" wrench or socket. Repeat procedure for clamp on other side.
- d. Push down on front lock handles and recheck pressure by pulling up on rip fence. If rip fence is too loose, repeat adjustment.

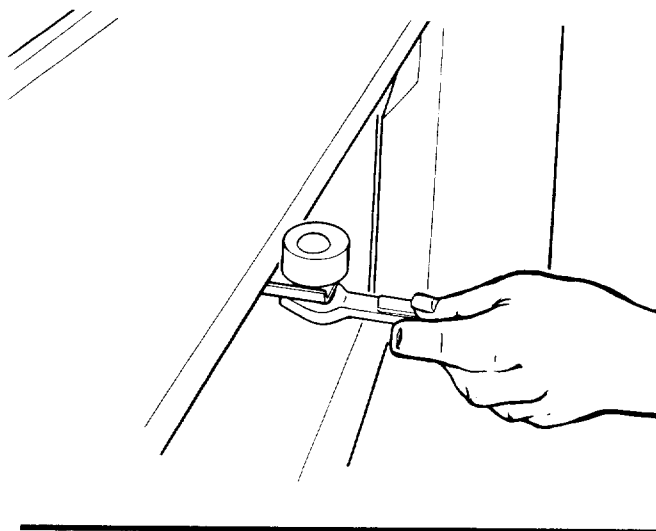

STEP THREE

Squaring Crosscut Travel

NOTE: This adjustment helps ensure the blade accurately travels square to the rip fence.

1. Index arm at 0° miter and lock.
2. Install saw blade as shown. Motor shaft has left handed threads - turn nut counterclockwise to tighten.

CAUTION: Do not overtighten arbor nut. Use arbor wrench to "snug" nut in place. Overtightening could distort the blade collars and cause blade to wobble.

3. Lower arm until saw blade just clears the front table. Be sure the miter lock handle and the bevel lock handle are locked.

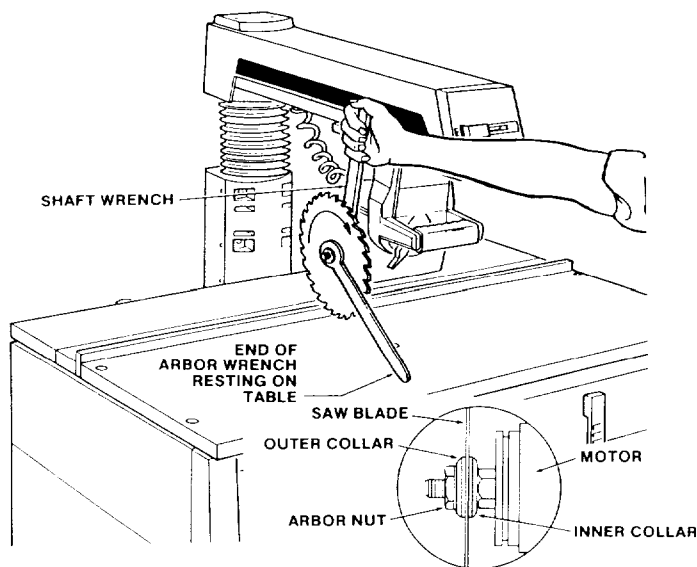

4. Place a framing square on the table as shown and position the blade and square until the leg of the square just contacts a tooth of the blade. Mark this tooth with a pencil.

NOTE: The framing (or combination) square must be "true" - see start of "Assembly and Alignment" section on page 10 for checking method.

5. When the carriage is moved back and forth on the arm, the marked tooth should just touch the square at all points. If marked tooth moves into square or away from square the following adjustments are required.

- (a) Loosen the four (4) 1/4-20 socket set screws on both sides of the front column support (2 on each side) with a 1/8" Hex "L" wrench as illustrated on next page.
- (b) Move the arm in the proper direction to make marked tooth follow edge of square when the saw blade is moved along arm in a "crosscut" manner.

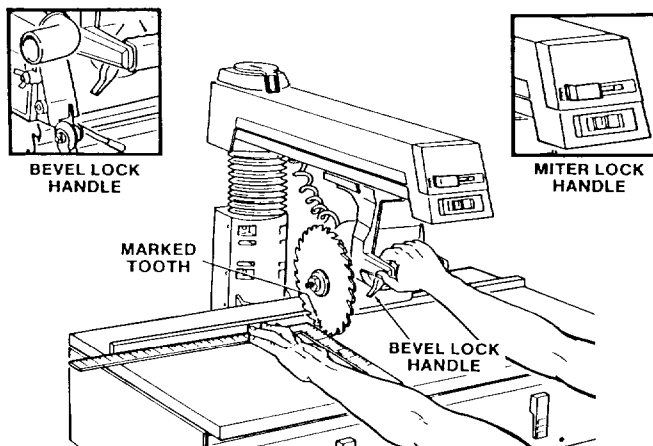

- (c) Carefully retighten upper two (2) 1/4-20 socket set screws alternating from left side to right side so as not to force arm out of adjustment.
- (d) Recheck blade travel. Adjust arm position as needed by readjusting upper screws only.
- (e) Once arm position is good, tighten lower 1/4-20 socket set screws. Do not overtighten. Check elevating handwheel for ease of rotation. If rotating handwheel is difficult, readjust socket set screw tightness as needed.

NOTE: The life of your saw table will be lengthened considerably if you will cover the front table with a fitted piece of 1/4 inch plywood. This should be tacked in place for easy replacement. Use of such a cover will allow you to do all cutting into the cover, rather than your table top. This will help prevent dulling of the saw blade and striking table mounting hardware. Place tacks out of the path of the saw blade.

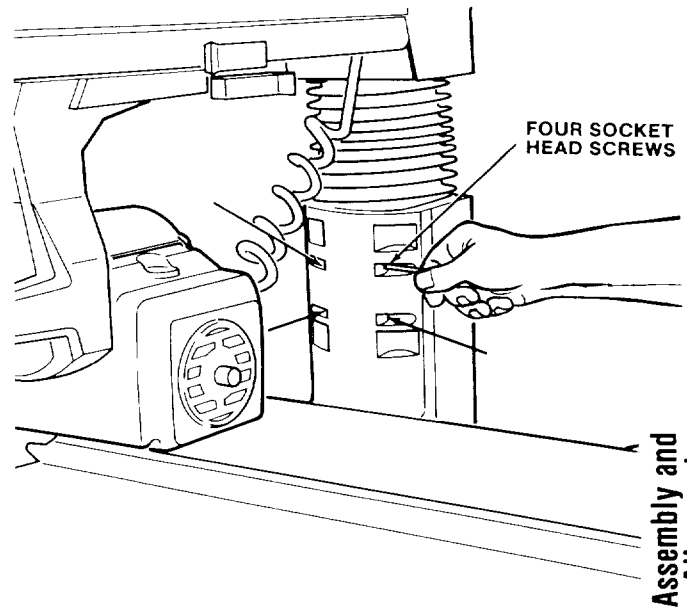

Assembly and Alignment

- (f) Set miter indicator on 0° position as shown.

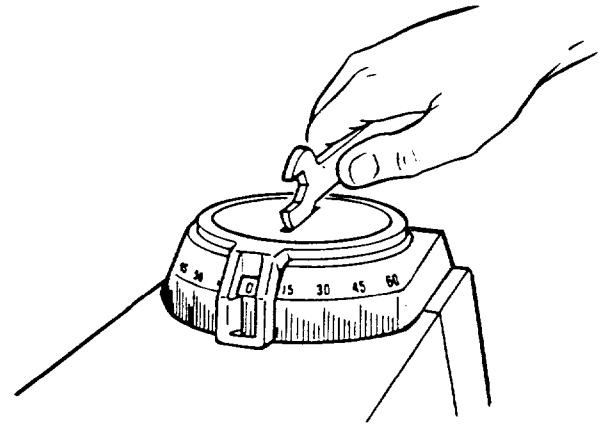

STEP FOUR

Squaring Saw Blade to (Work) Table

NOTE: If alignment procedure step two was not performed, this adjustment cannot be accomplished.

1. Place a framing square on the table with the short leg against the saw blade. Do not allow the square to rest against a "set-out" tooth; it must rest flat against the blade side.
2. If the square does not touch the saw blade as shown (with square held firm against table top) the following adjustments are required.
 - (a) Tighten rip lock handle.
 - (b) Unlock bevel lock handle. **Do not** un-index motor.

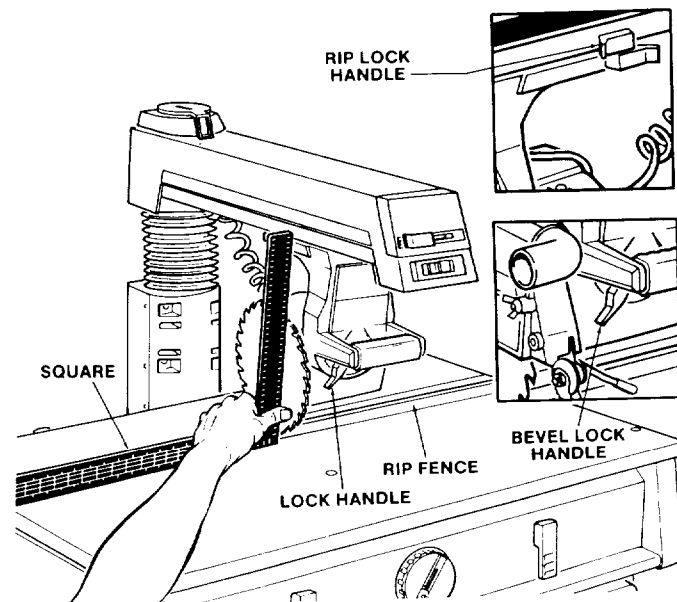

(c) Loosen the four (4) socket set screws located behind yoke as illustrated with a 1/8" Hex "L" wrench. Rotate motor while holding square firmly against saw blade and table top until the square touches the sawblade as shown.

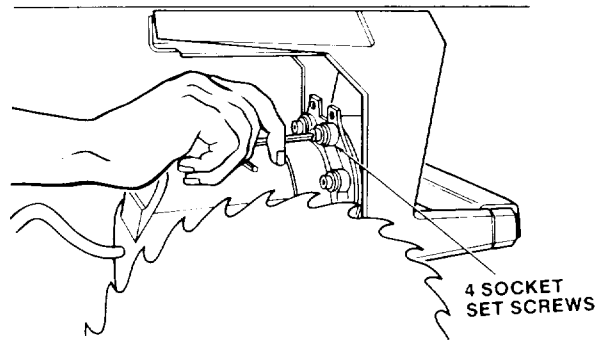

(d) Lock bevel lock handle. Recheck alignment to make sure blade did not move when bevel lock handle was locked.

(e) Tighten the four socket set screws. Unlock bevel lock handle, unindex the motor, re-index and relock the bevel lock handle. Recheck alignment again. If blade is not square to table, return to step (c) and repeat.

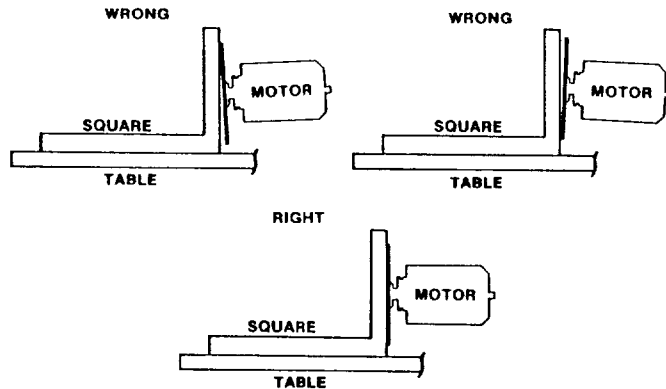

(f) To assure the blade is square to the table, elevate the arm enough to bevel the motor to 45° stop. Then return to 0° position, lower the arm and lock bevel lock handle. Recheck alignment.

(g) Install bevel scale indicator by inserting one end into the opening in the yoke. Slide the indicator to one side and push until it snaps in place. Tabs are located on the outside of the opening. Adjust indicator by sliding red line to 0° position.

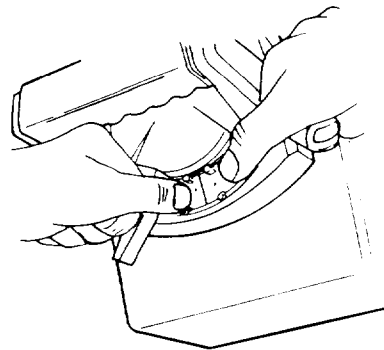

STEP FIVE

Squaring Blade to Rip Fence

NOTE: If alignment procedure steps three and four were not performed, this adjustment step cannot be accomplished. This adjustment helps avoid binding (kickbacks) or splintering of wood surface, or burning of the kerf.

1. Position carriage as shown and tighten rip lock handle. Place a framing square against the rip fence and the saw blade, as shown. The long leg of the square must be held firmly against both the fence and the table top, and the short leg must not touch any of the "out-set" teeth on the saw blade. Check at several points of blade rotation.
2. If the square does not touch the blade at both of the two points as shown, a heel condition exists.
3. To correct "heel" condition, proceed as follows:
 - (a) Unlock swivel lock handle.

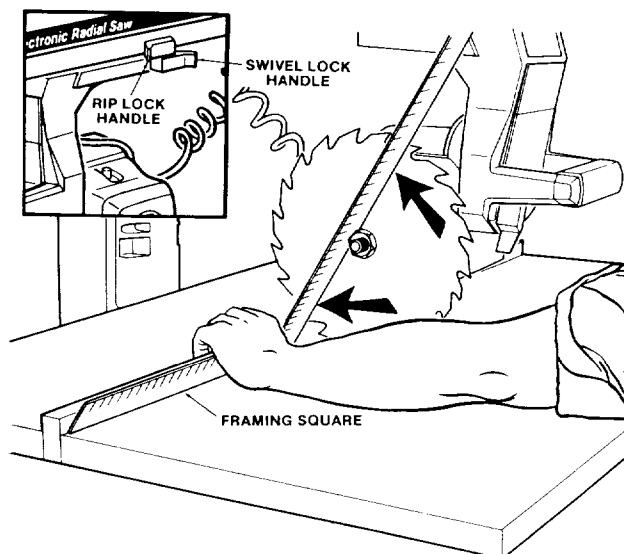

- (b) Using a 1/8" Hex "L" wrench loosen the four socket set screws located through access holes on bottom side of yoke as illustrated.
- (c) Rotate the yoke assembly until blade is aligned properly.
- (d) Lock swivel lock handle and retighten the four (4) socket set screws. Recheck for heel. If heel condition exists, return to step (b) and repeat.

NOTE: This alignment procedure will simultaneously set both yoke indexing positions for blade in and out rip

NOTE: It may be necessary to use pliers to grip the short end of the Hex "L" wrench to loosen or tighten the socket cap screws. Remember to wear eye protection when performing this procedure.

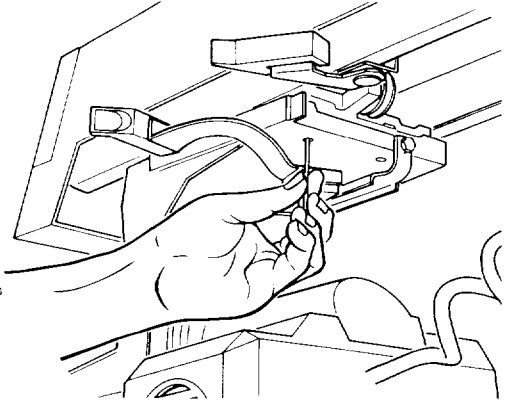
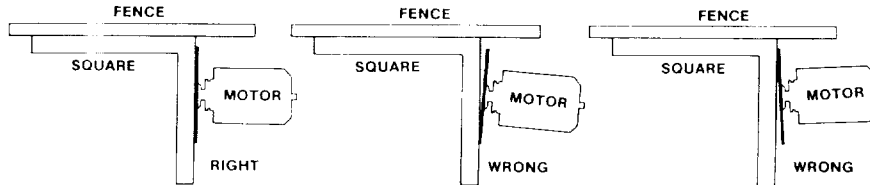

Assembly and Alignment

Bevel Heel Adjustment

This adjustment helps avoid the grabbing or throwing of the wood during edging operations.

1. With sawblade in 90° crosscut position, elevate saw, then rotate motor to its vertical position (blade parallel to table top). Lock bevel lock handle and be sure swivel lock handle is in locked position.
2. Check blade for bevel heel by positioning square perpendicular to fence and between blade and table as shown. Lower arm until face of blade rests on square. Be sure square is resting on face of blade and not on a "set-out" tooth as this will result in a false measurement.
3. If there is a visible gap between saw blade face and the edge of the square, a bevel heel condition exists and the following adjustment is necessary.
 - a. Unlock the bevel lock handle and loosen the two cap screws located thru the rear of the motor support (see illustration). A 1/8" hex "L" wrench is needed to loosen these screws.
 - b. Lift or lower the rear of the motor support until the gap between the blade and square disappears. Lock the bevel lock handles.
 - c. Tighten the two cap screws and recheck alignment between the face of the blade and the square. If a gap condition exists, repeat the above adjustment.
 - d. From loose parts bag #497 find the motor support cap and install into rear of motor support.

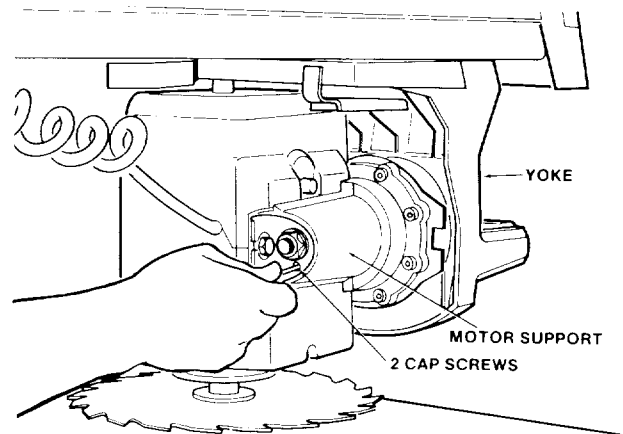
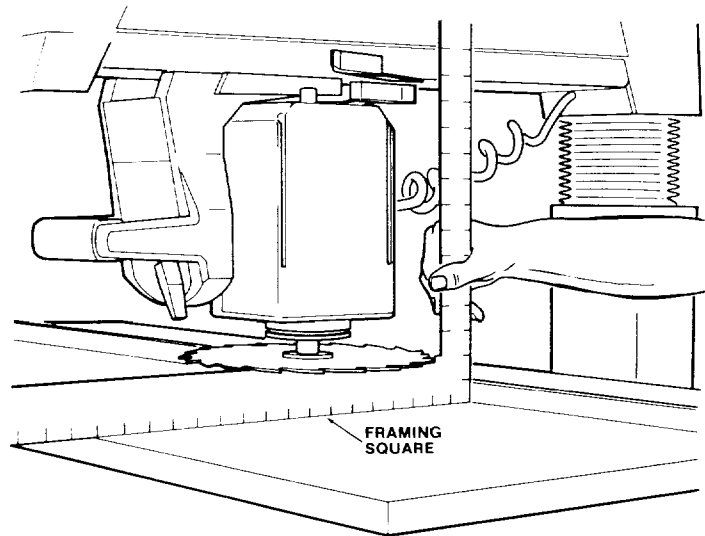

NOTE: It may be necessary to use pliers to grip the short end of the Hex "L" wrench to loosen or tighten the socket cap screws. Remember to wear eye protection when performing this procedure.

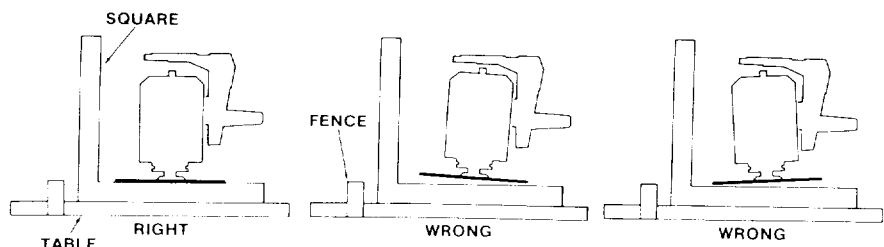

STEP SIX

Installing Blade Guard and Adjusting Anti-Kickback Pawls and Spreader

1. Install blade guard on motor.
2. Unlock the swivel lock handle and rotate the blade into the IN-RIP position. Lock the swivel lock handle.
3. Position blade against fence and lock the rip lock handle. Loosen wing screw and lower the anti-kickback bar assembly until side of the spreader is flush against the fence and the anti-kickback pawl is resting on top of the fence (as illustrated).

NOTE: If the spreader is not flush against the fence or will not easily clear the top of the fence when lowered, the following adjustment is required.

- a. Loosen the two hex nuts, one on each side of the spreader with 1/2" open end wrench.
 - b. Slide the spreader with fingers until the side of the spreader rests flush with the rip fence.
 - c. Snug both nuts against the spreader and recheck alignment.
 - d. If spreader aligns with fence and blade, tighten with wrench and raise anti-kickback spreader up to guard and retighten wing screw.
4. Release rip lock handle, move blade away from fence and rotate to crosscut position.
 5. From loose parts bag #497, locate the blade guard rear bumper pad and install.

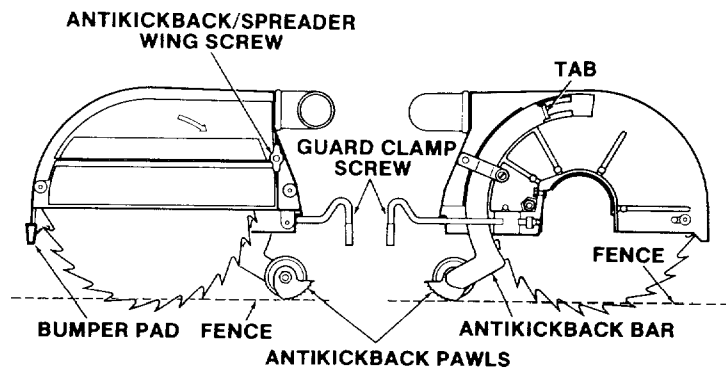
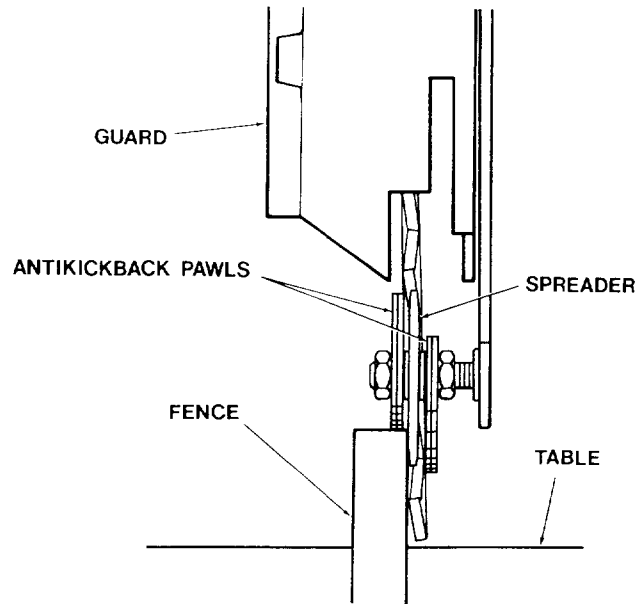

STEP SEVEN

Installing and Adjusting Rip Scale Indicators

NOTE: The rip scales and pointers are intended to be used for quick settings. Adjustments will be necessary for blades of different thicknesses. For greater accuracy take direct measurements between blade and fence with ruler or measuring tape.

1. Locate rip scale indicators in loose parts bag #497 and slide indicators onto mounting brackets.
2. Unlock swivel lock handle and move the blade into the OUT-RIP position. Lock the swivel lock handle.

3. Measure 2" from rip fence to nearest tooth on the blade and lock rip lock handle.
4. Adjust "out rip" scale indicator by sliding until indicator line reads 2 inches on the upper of the two "out rip" scales as illustrated. Out rip scales are located on left side of arm.
5. Unlock rip lock handle and move blade away from fence. Unlock the swivel handle and rotate the motor to the IN-RIP position. Lock the swivel lock handle.
6. Adjust "in-rip" scale indicator (located on right side of arm) by sliding until indicator line reads "0" inches.

location and function of controls

WARNING: FOR YOUR OWN SAFETY ALWAYS LOCK THE SWITCH "OFF" WHEN SAW IS NOT IN USE. REMOVE KEY AND KEEP IT IN A SAFE PLACE . . . ALSO IN THE EVENT OF A POWER FAILURE, TURN SWITCH OFF. LOCK IT AND REMOVE THE KEY. THIS WILL PREVENT THE SAW FROM STARTING UP AGAIN WHEN THE POWER COMES BACK ON.

WARNING: THE SAWBLADE, DADO, OR CUTTING TOOL MUST BE REMOVED FROM THE SAW ARBOR BEFORE USING THE ACCESSORY SHAFT, NEVER OPERATE THE SAW WITH CUTTING TOOLS (INCLUDING SANDING ACCESSORIES) INSTALLED ON BOTH ENDS OF THE SAW ARBOR. MAKE SURE THE UNUSED ARBOR IS ALWAYS COVERED BY A GUARD, A CAP, OR THE ARM.

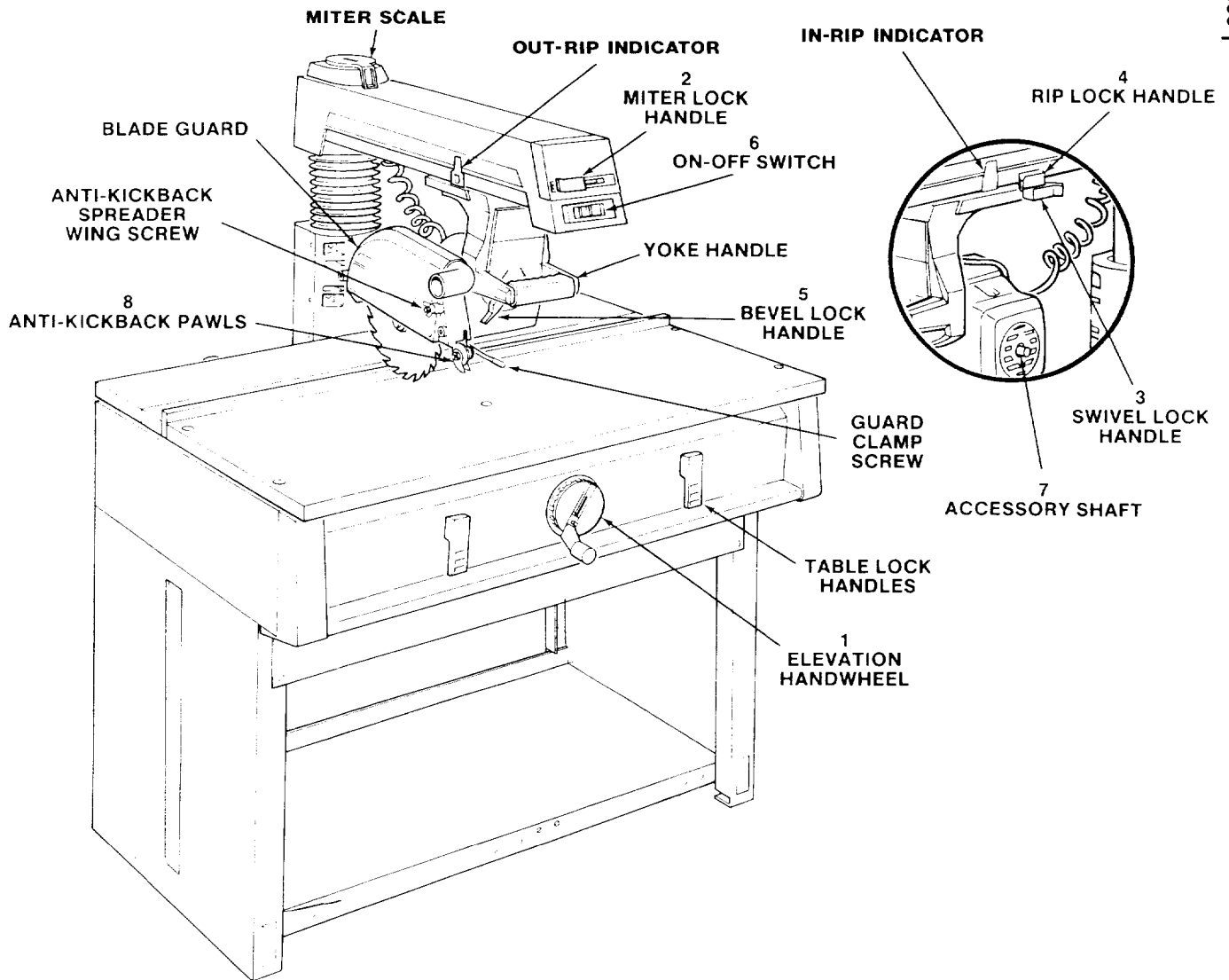

Location and Function of Controls

1. Depth of Cut (Elevation)

- The diagram shows the elevation crank which is used to raise and lower the saw blade.
- Clockwise rotation raises the blade . . . counterclockwise rotation lowers it. One complete turn of the handle will raise or lower the saw blade 1/16 inch.
- Handle can be folded in when not in use.

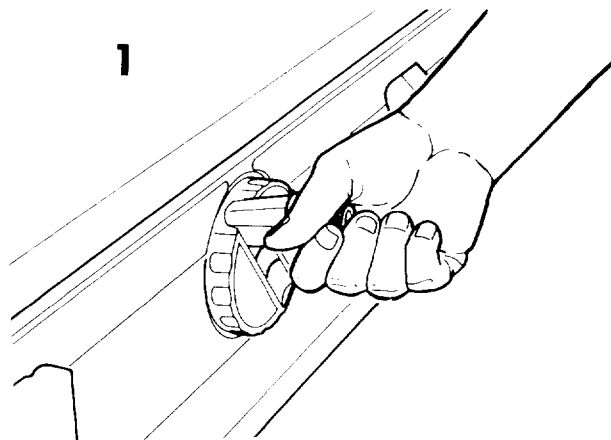

2. Angle of Cut (Miter)

Proper Indexing Method - Experienced operators of woodworking equipment such as this Craftsman Radial Saw, acquire the habit of indexing in one direction only, whenever a new setting is made in preparation for a different operation.

Example: When moving the arm to a miter index position move it slightly past the desired index position, then return to the index position carefully to index and lock. Yoke indexing and bevel indexing can be accomplished in a similar manner. This indexing technique tends to neutralize any stresses impaired upon saw components and contributes to the high degree of accuracy the saw is capable of producing when operated expertly.

- The miter lock handle locks, unlocks and indexes the arm for left and right miter cuts.

NOTE: For safety reasons stops have been provided to prevent 360° rotation of the radial arm.

- The radial arm has positive index positions at 0° and 45° left and right. The arm is rotated by pulling the miter lock handle from left to right and releasing the index pin. Move the arm to the desired miter angle and push the miter lock handle back to the lock position.

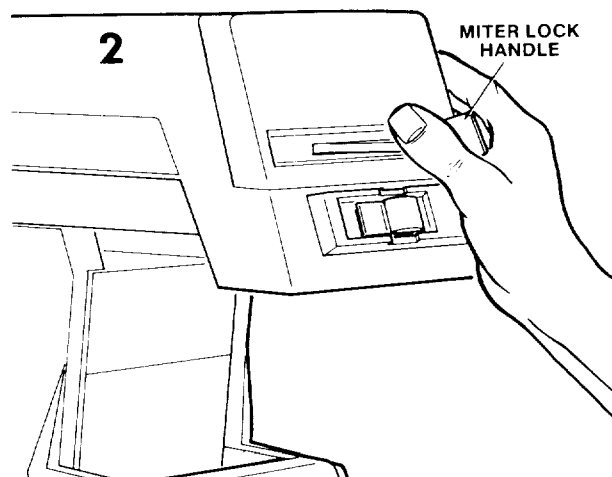

3. Yoke Swivel (Ripping)

- Swivel lock handle is to lock, unlock and index the yoke swivel adjustment.
- The yoke swivel index pin automatically indexes the yoke at 90° position. Pull the swivel lock handle forward to unlock the yoke, continue to pull this handle until the index pin is released.
- The swivel lock handle locks the yoke to the carriage in any position. Pull the handle forward to release the yoke; push the handle rearward to secure the yoke.

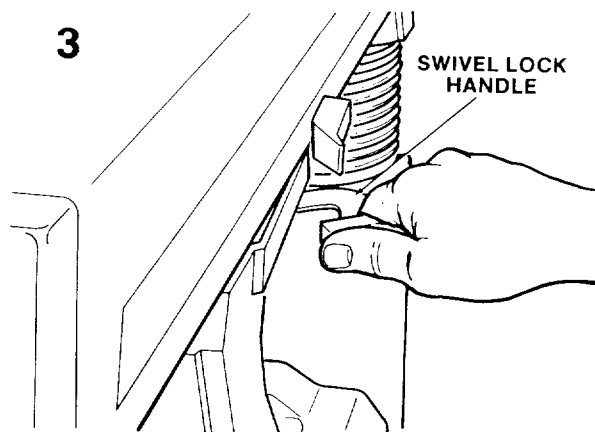

4. Rip Position Lock

- The rip lock handle is pushed rearward to lock the carriage on the radial arm and pulled forward to release it.
- When performing crosscutting operations, the rip lock handle must be released so the carriage is free to travel along the arm. The lock handle should be tightened until the operator is ready to grasp the yoke handle and make a cut.

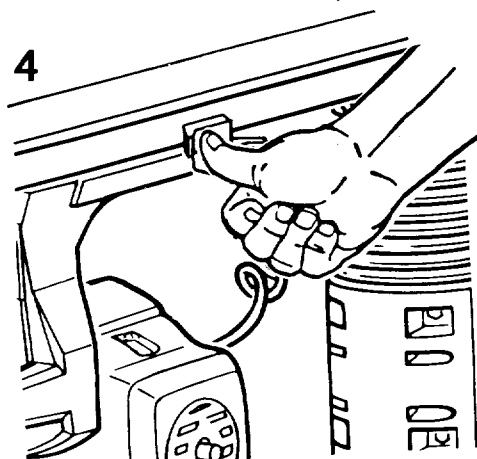

5. Blade Angle (Bevel)

- A single bevel lock handle is used in angular positioning and indexing of the motor, to provide the desired saw blade (bevel) angle.
- The bevel lock handle controls the angular position of the motor with respect to horizontal.
- The bevel lock handle automatically indexes the motor at 0°, 45° and 90°. Slide the bevel lock handle to the far right while positioning the blade, then release it. At any other position it does not engage.
- The bevel lock handle also locks the motor to the yoke when the motor is in any position. Pull lever to right to release and push to left to lock.

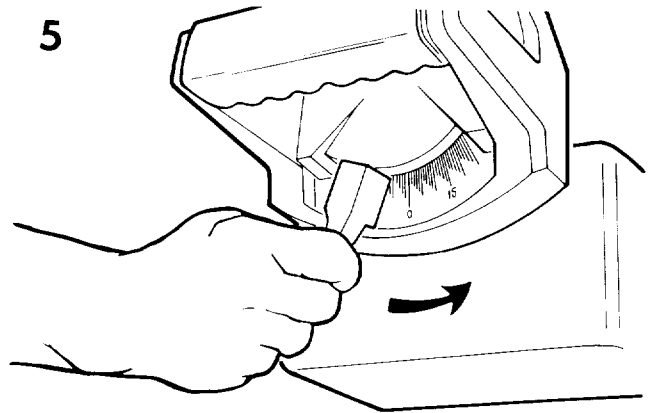

6. Power Switch and Key

- To turn switch on, insert key into switch lock.

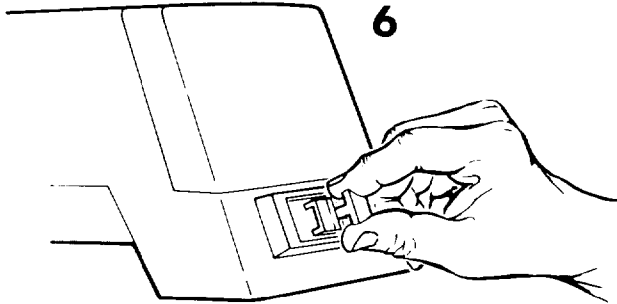

- To turn switch on, insert finger under end of switch lever and pull end out.

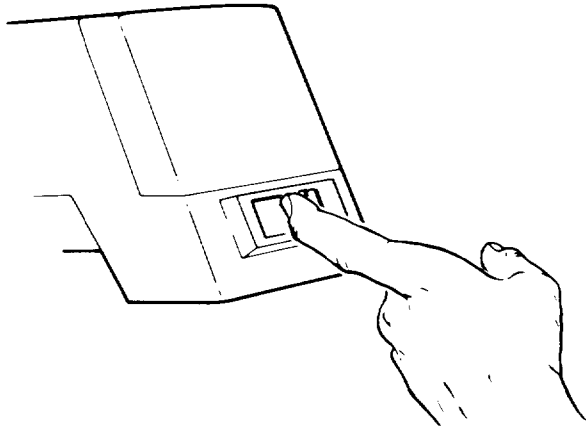

- Push lever in to turn switch off.

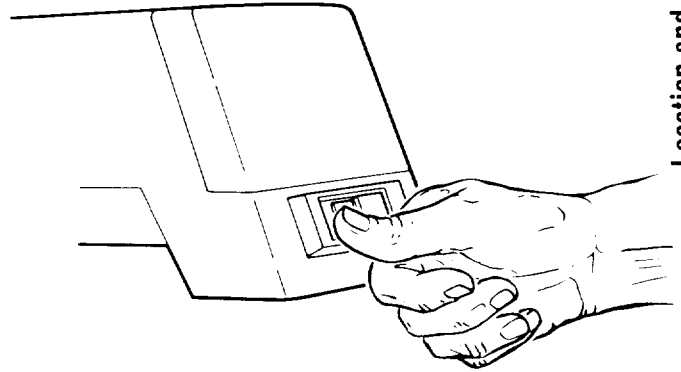

- WARNING: THIS LOCKING FEATURE IS PROVIDED TO HELP PREVENT UNAUTHORIZED USE OF YOUR SAW. ALWAYS REMOVE THE KEY AND KEEP IT IN A SAFE PLACE. TO REMOVE KEY, HOLD THUMB ON END OF LEVER TO KEEP SWITCH IN "OFF" POSITION AND PULL KEY STRAIGHT OUT.**

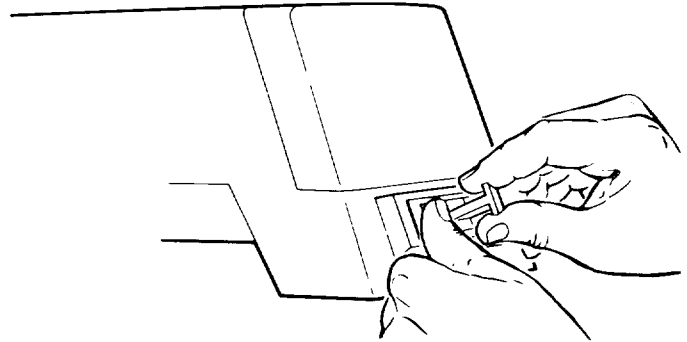

7. Accessory Shaft

Use only the following recommended accessories: Drill chuck, Sanding drum, and Router adapter.

CAUTION: The sawblade, dado, or cutting tool must be removed from the saw arbor before using the accessory shaft, NEVER operate the saw with cutting tools (including sanding accessories) installed on both ends of the saw arbor.

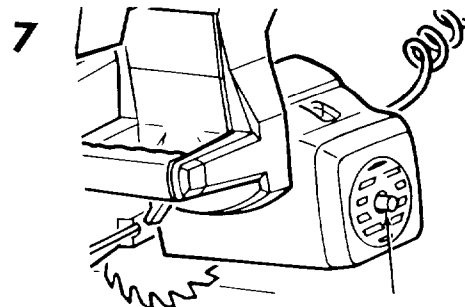

ACCESSORY SHAFT

8. Blade Guard and Anti-Kickback/Spreader Assembly - Positioning for Ripping.

WARNING: NEVER POSITION THE GUARD OR ANTI-KICKBACK/SPREADER ASSEMBLY WITH THE SAW RUNNING. NEVER POSITION THE ANTI-KICKBACK/SPREADER ASSEMBLY BY GRASPING THE PAWLS OR SPREADER. TO MAINTAIN SPREADER ALIGNMENT, USE THE TAB LOCATED ON THE ANTI-KICKBACK BAR.

- a. The blade guard is positioned by loosening the guard clamp screw and rotating the guard so that the "nose" just clears the workpiece as shown.

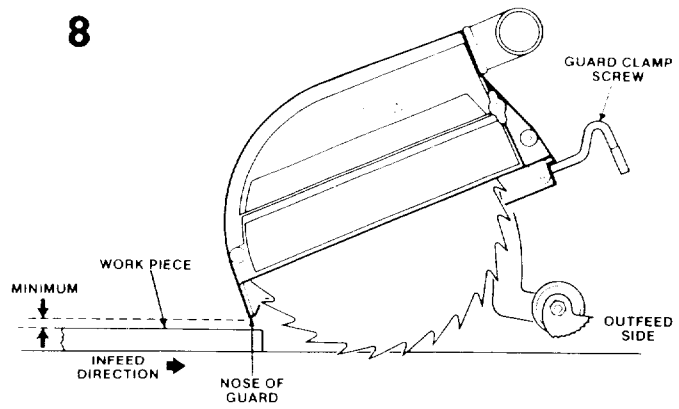

This adjustment is necessary to:

- 1) Protect the operator from accidentally contacting the sawblade from the "infeed" direction.
 - 2) Prevent the workpiece from being lifted from the table by the sawblade thus minimizing lifting or fluttering (particularly with thin and/or light workpieces).
 - 3) Minimize sawdust from being thrown toward the operator.
- b. The anti-kickback and spreader assembly is adjustable to accommodate the thickness of the board being ripped.

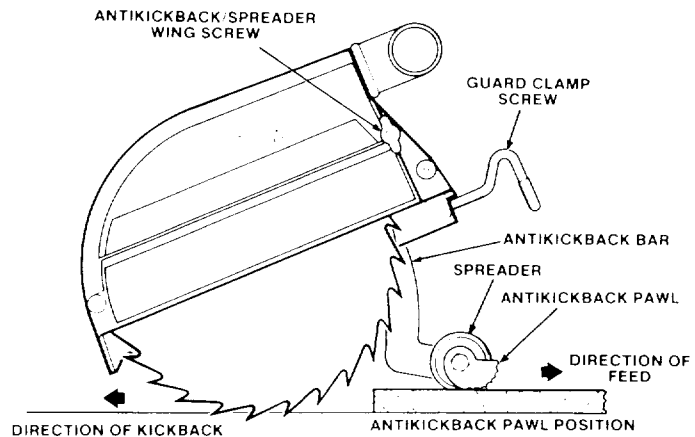

For ripping the anti-kickback and spreader assembly is positioned by loosening the wing screw and, with the tab provided, positioning the anti-kickback and spreader assembly until the pawls assume approximately the position shown. Tighten the wing screw.

Make sure by trial - without saw running - before starting the cut that the anti-kickback pawls will stop a kickback once it has started. Insert workpiece alongside spreader under outer set of pawls by approaching pawls in the feed direction. Push workpiece sharply in the direction of a kickback (opposite direction of feed). Readjust pawls if they do not stop the kickback motion by biting into the workpiece.

If the leading edge of the workpiece does not feed smoothly under the pawls, the spreader may be set too deeply. Loosen the wing screw, raise the spreader slightly, retighten the screw, recheck workpiece in-feed and kickback pawl function.

These adjustments when properly made will:

- 1) **Reduce possibility of kickbacks** by preventing the kerf from closing on the sawblade.
- 2) **Prevent "wrong-way feed"**. "Wrong-way feed" is feeding the workpiece - when the sawblade is in a rip position - into the outfeed side of the cutting tool (sawblade, dado, molding head, etc.), the side containing the anti-kickback pawls/spreader. This can be extremely hazardous because the sawblade may grab the workpiece and throw

it violently toward the nose of the guard (infeed side of the tool) possibly pulling your hand with it before you can react. See Danger label on outfeed side of the guard just below the dust elbow.

"Wrong-way feed" differs from kickback". A

"kickback" is generated by the sides (one or both) of the teeth, because of binding between the fence (heel), pinching of the sides of the sawblade (failure to use spreader), a dull blade, and/or inadequate set of teeth of sawblade.

- 3) **Act as a partial guard** regarding accidental contact with the sawblade at the outfeed side when ripping.

For crosscutting the anti-kickback and spreader assembly is positioned by loosening wing screw. With the tab provided position the anti-kickback spreaders assembly until the pawls just clear the workpiece or fence whichever is higher.

basic saw operation

WARNING: TO AVOID MISTAKES THAT COULD CAUSE SERIOUS PERMANENT INJURY, OBSERVE ALL THE FOLLOWING INSTRUCTIONS IN ADDITION TO THOSE ON PAGES 2-6.

Basic saw operations are summarized in six categories, explained and illustrated in the following paragraphs.

NOTE: Refer to paragraphs under "Location and Function of Controls" for illustrations and description of controls. Page 23.

CUTTING A KERF IN THE WORK TABLE AND FENCE

NOTE: The life of your saw table will be lengthened considerably if you will cover the front table with a fitted piece of 1/4 inch plywood. This should be tacked in place for easy replacement. Use of such a cover will allow you to do all cutting into the cover, rather than your table top. This will help prevent dulling of the saw blade and striking table mounting hardware. Place tacks out of the path of the sawblade.

1. Elevate arm so that the blade clears the top of the fence and then push the motor to its most rearward position.
2. Lower the arm so that the blade just clears the rear table. Note: The rear table should be at the same level as the front table (see "Leveling Front Work Table", page 16). If front table cover is used, set blade so that it just clears the front table board cover.
3. Lock the rip lock handle and check to make sure carriage is locked in place. Plug saw into a grounded outlet. (See section titled, "Electrical Connections", page 7.)
4. Insert the yellow key into switch and, while holding the yoke handle, turn the switch on.
5. With the motor on, turn the elevation handle counterclockwise to lower the sawblade to where it just cuts into the table approximately 1/32 to 1/16 inch deep. While holding the yoke handle and with motor still on, unlock the rip lock handle and then pull the motor forward and out to the front stop on the arm. This will allow the blade to cut through the fence and to cut a shallow kerf in the table 1/32 to 1/16 inch deep to provide for the blade cutting completely through the workpiece.

NOTE: A kerf will have to be cut into the table prior to making any thru cutting operation using this procedure.

REQUIREMENTS FOR CROSSCUTTING TYPE OPERATIONS

(Operations 1 through 4)

Always position the workpiece firmly against rip fence (guide) and lay it flat on work table surface.

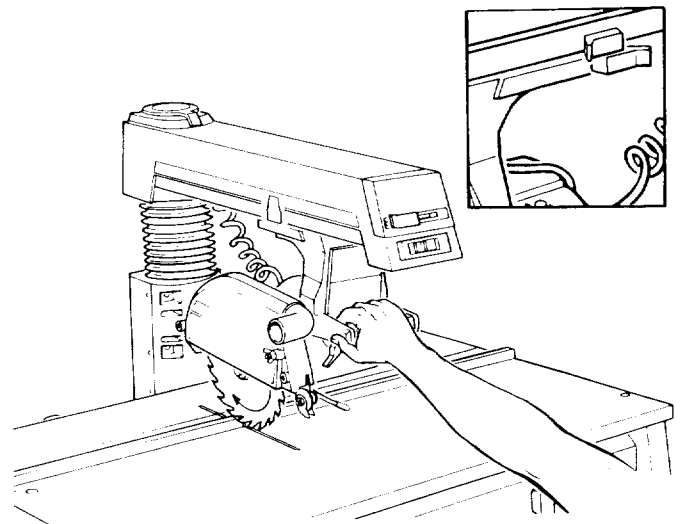

NOTE: To maintain table strength, workpiece stability, control forward motor of carriage, and avoid accidents, always:

1. Use only blades that are sharp, correctly set and undamaged.

2. Make sure the arbor nut is snug.
3. Clamp the guard in a horizontal position.
4. Lock the swivel lock handle. Make sure it is firmly locked. (See page 24.)
5. Hold work firmly against table and fence. To avoid tipping or throwing of workpieces thicker than the fence is high, install a higher fence (at least workpiece thickness). Always place the fence in the most forward position (farthest from the column support) compatible with the workpiece being processed and the operation being performed. With the carriage fully retracted, the blade must not contact the workpiece when placed against the fence, within the stated capacities of your saw. Do not confine the cutoff piece with your hand, length stop or any other item. The blade could throw it, causing an accident.
6. Keep hands well away from saw blade. Do not place hands where sudden blade or workpiece movement could cause hand to slip into the path of the blade. Always keep the hand holding the workpiece visible at all times.
7. Lock the bevel lock handle. Make sure it is firmly locked. (See page 25.)
8. Adjust the elevation so blade will cut into the table cover or table not more than 1/32 inch.
9. To adjust the anti-kickback and spreader assembly so the pawls just clear the workpiece and the fence. (See page 26.)
10. Pull saw forward just enough to cut the lumber in two, and then return the saw to its full rear position. It is dangerous to pull blade too far out beyond the piece being cut. When it is returned it can pick up the board and throw it over the fence.

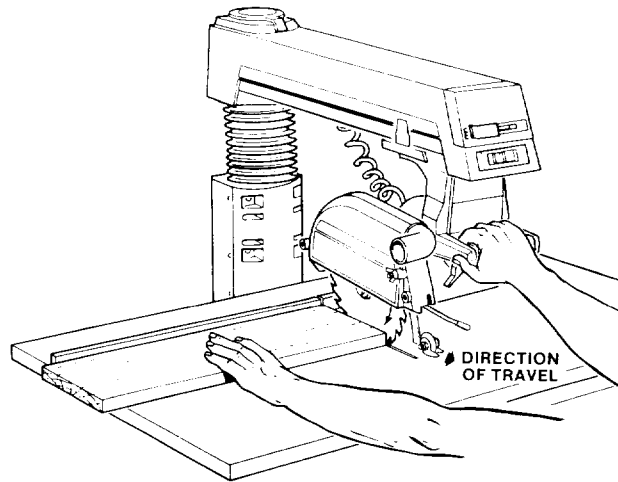

PROPER

(SEE ITEM "10" AT LEFT)

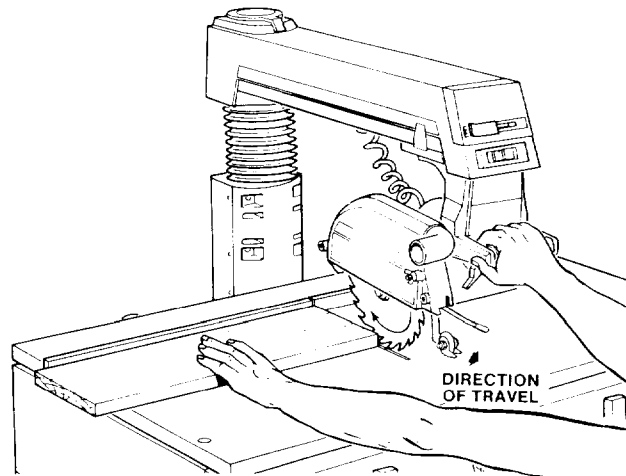

IMPROPER

(SEE ITEM "10" AT LEFT)

OPERATION NO. 1 - CROSSCUT

Crosscutting is the process of sawing across the width of the workpiece by pulling the saw blade through it and using the fence as a support for the edge of the workpiece. Never crosscut free-hand.

WARNING: YOU WILL NOTICE THAT WHEN PULLING THE SAW BLADE TOWARD YOU DURING CROSSCUTTING THE BLADE TENDS TO FEED ITSELF THROUGH THE WORKPIECE. THIS IS DUE TO THE ROTATION OF THE BLADE. TO CONTROL THIS YOU SHOULD DEVELOP THE HABIT HOLDING YOUR RIGHT FOREARM IN LINE WITH THE ARM OF THE SAW THROUGHOUT THE CUT. ALSO MAKE SURE THE CARRIAGE BEARINGS ARE ADJUSTED PROPERLY SO CARRIAGE DOESN'T TRAVEL TOO FREELY.

OPERATION NO. 2 - MITER CROSSCUT

Miter crosscutting is the process of sawing across the width of a workpiece at any angle other than a 90° (square) cut. The 45° miter angle is a popular one, since two boards cut to 45° can be assembled to form a 90° corner for producing a square or

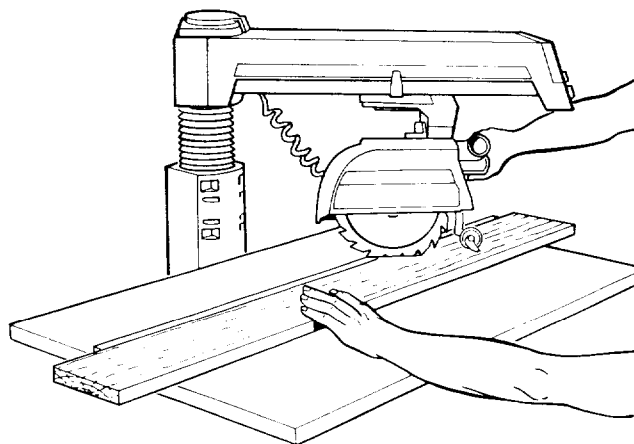

rectangular frame. The radial arm is set to a desired angle of cut, swivel and bevel settings at 0° and locked. The workpiece being cut is positioned and held firmly against the fence and the carriage pulled forward along the radial arm just far enough to complete the cut. Carriage should then be returned to the full rear position and locked. Allow the saw blade to come to a stop before removing the workpiece from the saw table.

OPERATION NO. 3 - BEVEL CROSSCUT

Bevel crosscutting is the process of sawing at 90° (square) across the width of a workpiece with the saw blade set to an angle other than 90° to the table. The radial arm and yoke are indexed at 0° and locked securely in place. The bevel is set to the desired angle of cut and locked. The workpiece being cut is positioned and held firmly against the fence and the carriage is pulled forward along the radial arm just far enough to complete the cut. The carriage should then be returned to the full rear position and locked. Allow the saw blade to come to a stop before removing the workpieces from the saw table.

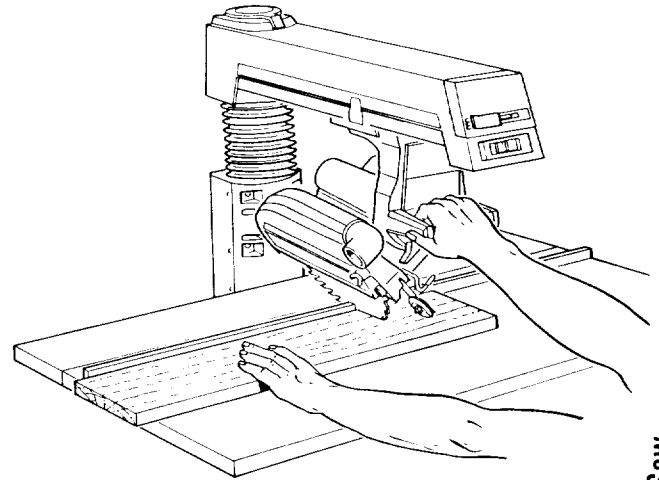

OPERATION NO. 4 - COMPOUND CROSSCUT

Compound crosscut is the combination of miter and bevel crosscut. The radial arm and the angle of the blade are set to produce the desired cut - the yoke is indexed at 0° and locked. The workpiece is positioned and held firmly against the fence and the carriage is pulled forward along the radial arm just far enough to complete the cut. The carriage should then be returned to the full rear position and locked. Allow the blade to come to a stop before removing the workpieces from the saw table.

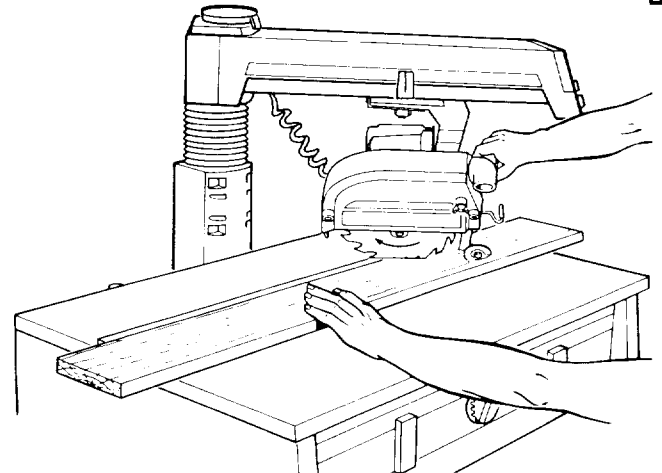

REQUIREMENT WHEN RIPPING

(Operations 5 and 6)

WARNING: TO AVOID MISTAKES THAT COULD CAUSE SERIOUS PERMANENT INJURY, OBSERVE ALL THE FOLLOWING INSTRUCTIONS IN ADDITION TO THOSE ON PAGES 2-6.

1. Make sure that the blade is sharp, correctly set and undamaged.
2. Lock the rip lock handle. (See page 24).
3. Lock the radial arm at the 0° position.
4. Make sure the workpiece is kept in firm contact with the fence and the table. The edge of the

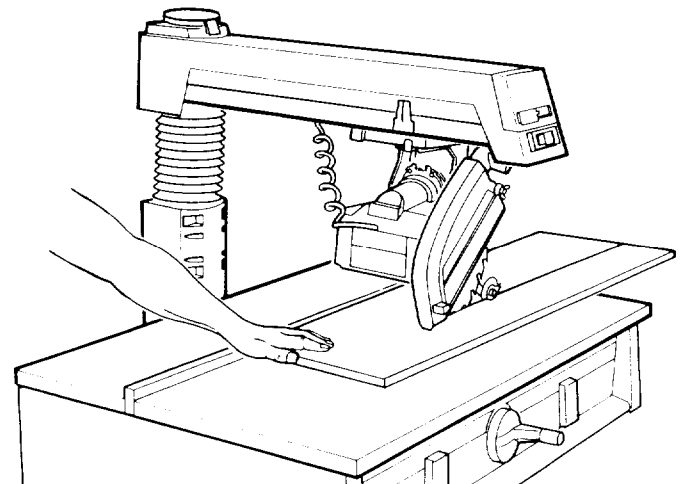

board against the fence must be straight and will not catch on kerfs in the fence. NEVER RIP "FREEHAND" (without aid of fence).

5. Properly set the anti-kickback and spreader assembly. Observe INSTRUCTIONS in paragraph "Positioning guard and anti-kickback and spreader assembly for ripping" under "Location and Function of Controls" page 23.
6. Never rip pieces shorter than the diameter of the blade.
7. When ripping narrow stock (less than 6 inches but more than 2 inches between the guard and the fence (guide) use a "PUSH STICK" (as shown) so the workpiece is clear of the blade before your hand reaches the guard. The end of the workpiece to which the push stick or push block (see below) is applied must be square to the fence and table.

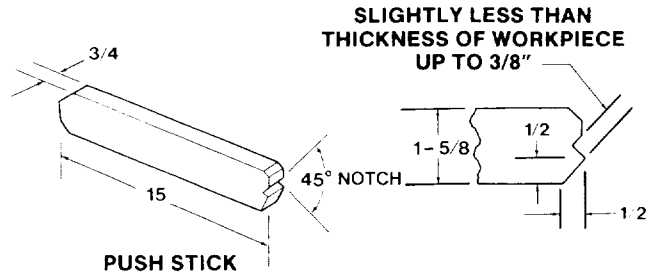
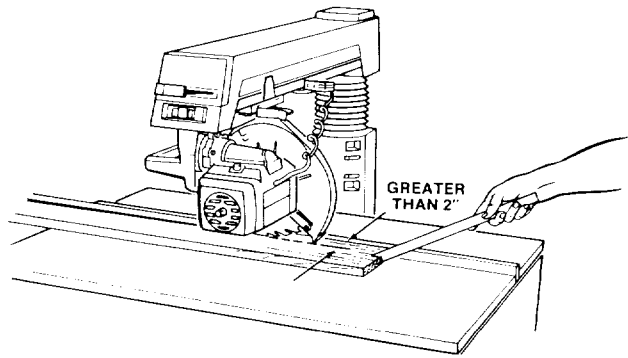

NOTE: All dimensions in inches.

8. When ripping stock 3/8" to 2" or less between the guard and fence (guide) use an auxiliary fence and push block. Make these work helpers to the dimension shown.

- a. **Make the auxiliary fence** using a piece of 3/8" and 3/4" plywood. Fasten together with glue and nails.

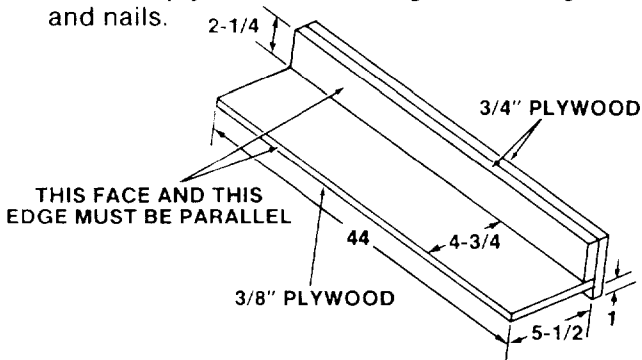

- b. **Make the push block** using a piece of 3/8" and 3/4" plywood.

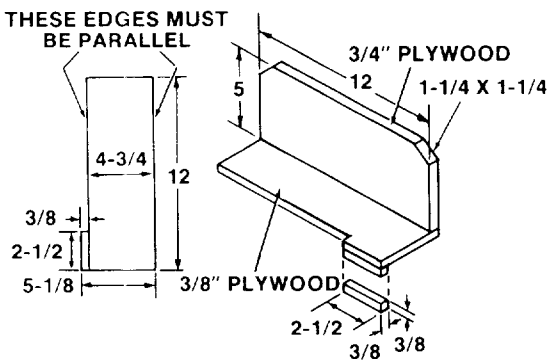

NOTE: All dimensions in inches

NOTE: Since the push block is used with the auxiliary fence the 4-3/4 inch dimension must be held identical on both of the pieces.

The small piece of wood 3/8 inch x 3/8 inch x 2-1/2 inch should be GLUED to the plywood ...

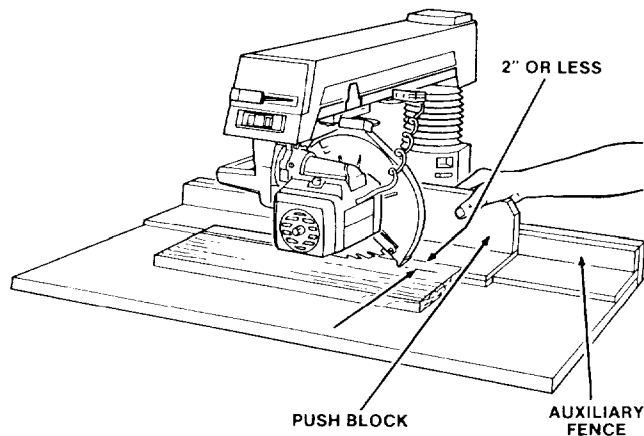

DO NOT USE NAILS. This is to prevent dulling the sawblade in the event you cut into the push block.

NOTE: To insure reliable support use only push block and auxiliary fences that have not been damaged by blade contact during use.

Position the handle at the edge of the plywood and fasten together with glue and wood screws.

The push block should feed the stock being ripped until the stock is clear of the rear of the blade, and then pulled back with use of the grip.

9. When ripping narrower than 3/8 inch position the saw blade to remove the narrow strip from edge of workpiece furthest from the fence. (See out ripping section below) Follow procedures as above based on distance from blade to fence.
10. Keep HANDS away from the saw blade.
11. Saw blade must be parallel to fence to minimize possibility of kickbacks.

OPERATION NO. 5 - OUT-RIPPING AND IN-RIPPING

1. Ripping is the process of sawing the workpiece along its length by feeding it into the sawblade when using the fence as a guide and as a positioning device to obtain the desired width of cut. The sawblade is parallel to fence.
2. Since the work is pushed along the fence, it must have a straight edge in order to make sliding contact with the fence. Also, the work must make solid contact with the table, so that it will not wobble or kickback. Provide a straight edge, to avoid kickback or binding, even if it means temporarily nailing an auxiliary straight edge board to the workpiece being ripped.

WARNING: IF THE WORKPIECE IS WARPED, DO NOT ATTEMPT TO MAKE A CUT IF THE WORKPIECE WOBBLER OR ROTATES ON THE TABLE. IT COULD BIND AND KICKBACK.

3. Always use the saw guard and make sure the spreader is correctly aligned with the kerf and the anti-kickback pawls are properly adjusted. Wood cut with the grain tends to spring the kerf closed and bind the blade and cause a kickback or slip of your hand. Always adjust the spreader to ride in the kerf and prevent the kerf from closing.
4. Stand a little to one side of the blade to be clear of workpiece in case of kickback.
5. Always push the workpiece past the blade so it is clear of the blade. This procedure will help avoid kickbacks. **DO NOT TOUCH** the cutoff piece until the power is off and the blade has stopped spinning.

IN-RIPPING

The radial arm and bevel are indexed at 0° and locked, but the yoke is turned 90 degrees in a clockwise direction (viewed from above) from the crosscut position. Thus, when standing in front of the saw, the blade would be rotating counterclockwise. After positioning the guard and anti-kickback mechanism the workpiece is fed from the right-hand side of the saw.

OUT-RIPPING

The radial arm and bevel are indexed at 0° and locked, but the yoke is turned 90 degrees in a counterclockwise direction (viewed from above), from the crosscut position. When standing in front of the saw, blade would be rotating clockwise. After positioning the guard and anti-kickback mechanism the workpiece is fed from the left-hand side of the saw.

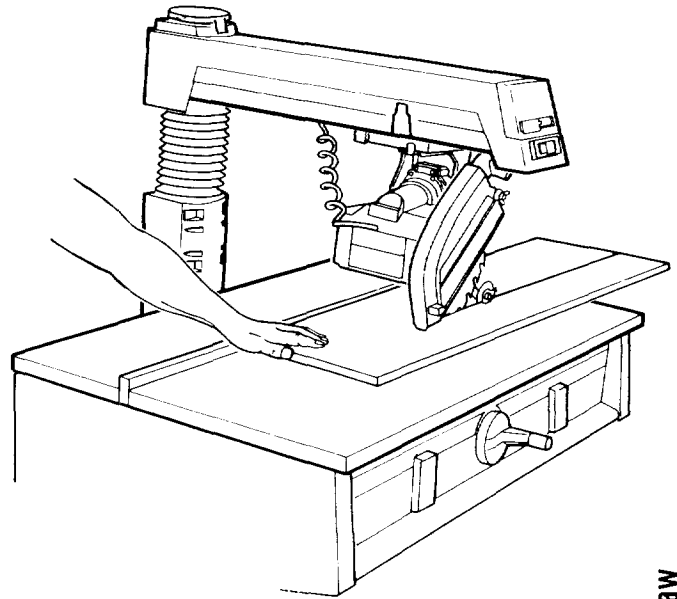

OUT-RIPPING

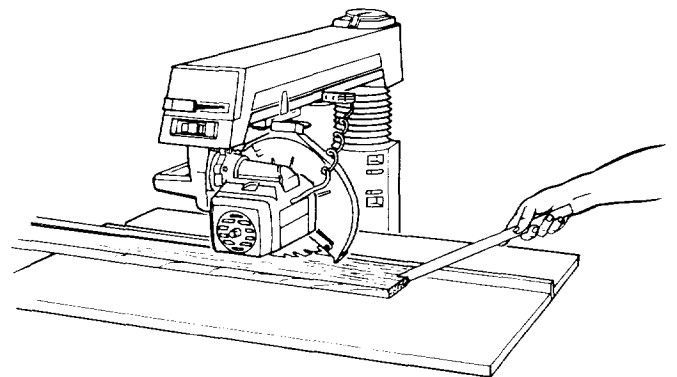

IN-RIPPING

OPERATION NO. 6 - BEVEL RIPPING

Bevel ripping is either in-ripping or out-ripping as described above, except the saw blade is tilted out of perpendicular to the saw table surface. The radial arm is indexed at 0° and locked, the bevel is set to the desired bevel angle and the yoke is positioned for in-ripping (saw blade at rear) or outripping (saw blade at front), as required. All requirements and observations applicable to normal ripping operations also apply to bevel ripping.

DADOING

Instructions for operating the different dado blades are contained in Owner's Manual furnished with the dado.

The saw arbor is designed for a dado up to 13/16 inches wide. Using a wider dado on the arbor could cause the dado and arbor nut to spin off. Take several passes of the dado if cut required is greater than 13/16 of an inch wide.

For best results and to avoid excessive load on the motor never cut a 13/16 of an inch wide dado deeper than 3/8 of an inch in one pass.

When installing the dado on the arbor, always install the inside "loose collar" first to ensure good arbor nut engagement. Do not install the outside blade collar. Make sure the arbor nut is snug. Install the arbor nut directly against the outside of the dado.

MOLDING

Instructions for operating the molding head are contained in an Owner's Manual furnished with the molding head.

EDGING

Use of the dado or molding head in the horizontal position (parallel to table) requires the proper accessory guard be used. (See recommended accessories page 43.)

Use of the dado or molding head in the horizontal position requires an auxiliary fence (page 33), or that the radial arm be positioned as follows:

1. Miter the arm to the left approximately 30°.
2. Swivel the motor until bottom of motor is parallel to and facing the rip fence and operating instructions label is visible.
3. Follow all steps outlined on motor label.
4. A copy of the label reads as follows:

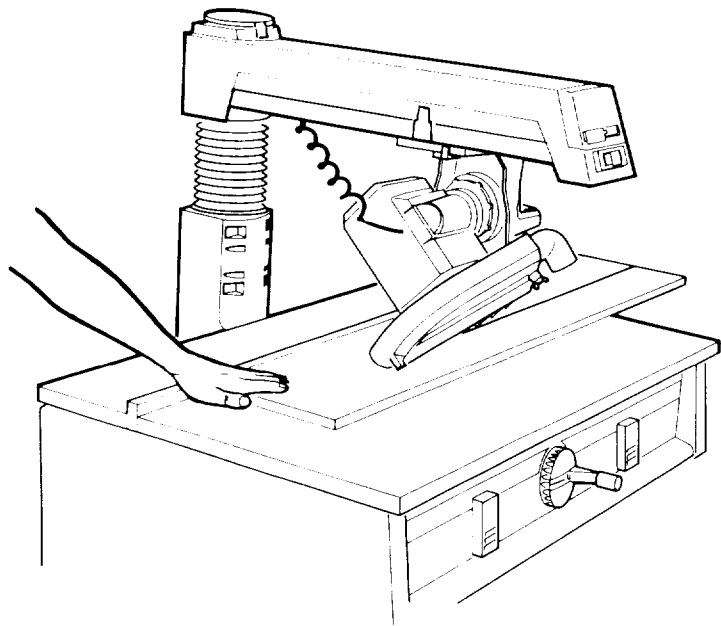
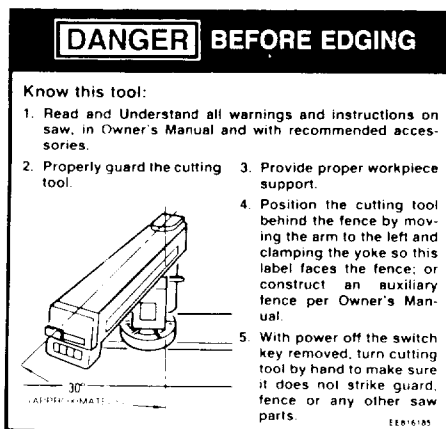

For use of the molding head or drum sander with saw arbor vertical the rear table requires an opening (next to rear face of fence) for arbor clearance. Cut opening directly below arbor in vertical position. Opening should be:

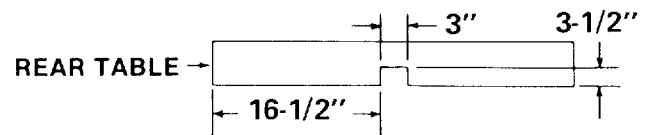

For top side use of the dado (**rabbeting**) or molding head in the in-rip position locate the desired position on the area and lock the rip lock handle. Lower the arm into the fence very slowly, remove only as much material from the fence as is necessary. This will provide maximum support for the workpiece.

WARNING: NEVER USE A DADO HEAD OR MOLDING HEAD WITH THE SAW ARBOR VERTICAL WITHOUT INSTALLING AND ADJUSTING A MOLDING HEAD/DADO GUARD. FOR TOP-SIDE DADOING OR MOLDING INSTALL AND ADJUST THE SAWBLADE GUARD AND ANTI-KICKBACK ASSEMBLY FOR RIPPING OR CROSSCUTTING AS APPROPRIATE.

AUXILIARY FENCE FOR MOLDING

To use the molding head with the arm in the 0° crosscut position an auxiliary fence must be used.

WARNING: IF THE AUXILIARY FENCE IS NOT USED WHEN THE SAW ARM IS IN THE 0° CROSS-CUT POSITION, THE MOLDING HEAD CANNOT BE LOCATED BEHIND THE FENCE FOR SAFE AND PROPER OPERATION.

Make the auxiliary fence from a piece of knot free pine. Cut to the following dimensions.

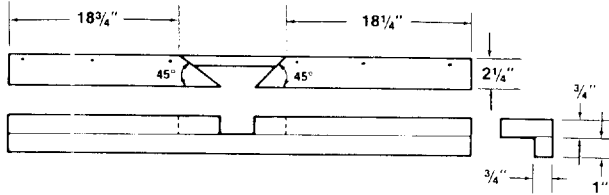

Follow the instructions that are contained in an Owner's Manual furnished with the molding head.

For use of the molding head or drum sander with saw arbor vertical the rear table requires an opening (next to rear face of fence) for arbor clearance. Cut opening directly below arbor in vertical position. Opening should be:

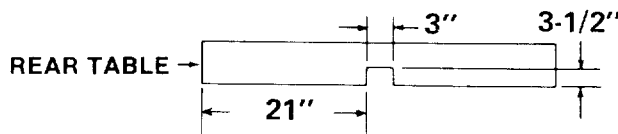

When using the accessory shaft, the guard, saw blade, dado, mold head or other cutting tool must be removed from the saw arbor before using the accessory shaft. Never operate the saw with cutting tools (including sanding accessories, buffing wheels and drill chuck) installed on both ends of the saw arbor.

To use the accessory shaft in the vertical position it is necessary to swivel the motor 90° before beveling the motor so the accessory shaft is in vertical

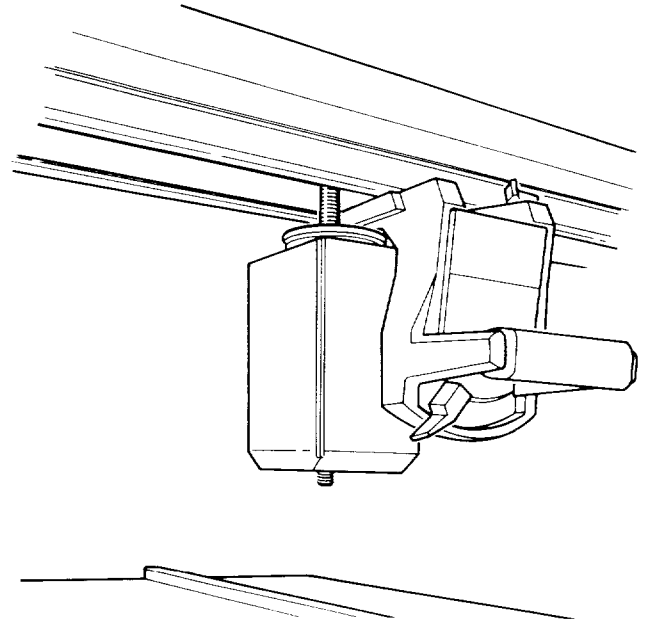
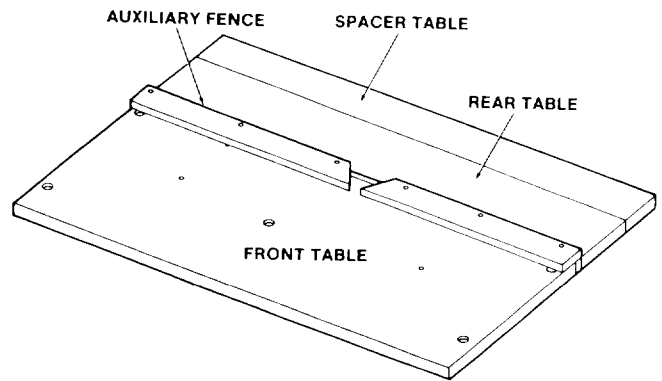

position. This is done so the blade arbor will be positioned under the arm for maximum protection to the operator. As illustrated.

adjustments to compensate for wear

ADJUSTING BEVEL LOCK LEVER

The purpose of this lever is to lock the motor at any bevel angle. An adjustment is required if the motor can be easily moved by hand when lever is locked or bevel lock lever offers minimal resistance when moving lever to the locked position. To make this adjustment:

1. Remove motor support cover.
2. Position motor at approximately 30° bevel angle and lock bevel lock lever.
3. With a 3/4 socket tighten the 1/2-13 hex nut located at the back of the motor support casting until the motor can no longer be easily moved by hand. Do not overtighten.
4. Unlock bevel lock lever and move motor to any of the five index positions. If the motor does not index securely the adjustment is too tight. Loosen 1/2-13 hex nut until bevel index pin seats properly.

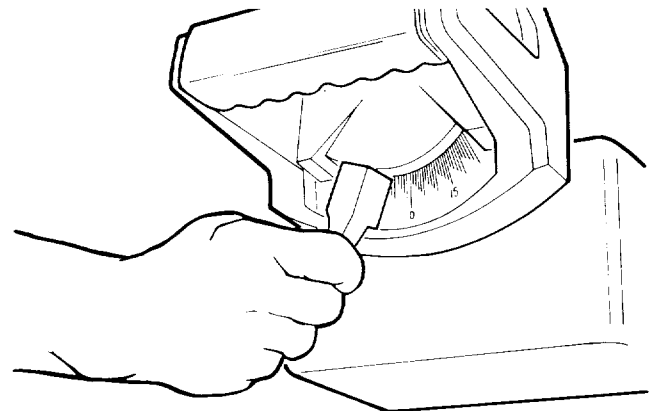

- Adjustment is complete when both locking and indexing functions are working properly. Replace motor support cover.

ADJUSTING SWIVEL LOCK HANDLE

This handle provides a friction lock between the upper face of the yoke and the bottom face of the carriage. It should eliminate any play or rotation between these two parts when locked. An adjustment is required if the yoke can be easily rotated by hand when handle is locked or yoke lock handle offers minimal resistance when moving handle to the locked position. To make this adjustment:

- With a 1/2 wrench or socket remove six (6) 5/16-18 hex head tapping screws and separate track from arm as illustrated.
- Slide yoke assembly from track. Keep carriage in line with track until rip lock mechanism clears end of track.
- With a 15/16 wrench or socket tighten the 5/8-11 hex nut until maximum effort is required to place yoke lock handle in the locked position.
- Unlock yoke lock handle and swivel yoke to an unindexed position. Return yoke to an indexed position. If the yoke does not index securely the adjustment is too tight. Loosen 5/8-11 hex nut until swivel index pin seats properly.
- Adjustment is complete when both locking and indexing functions are working properly.
- Slide carriage onto track starting with rip lock mechanism. Keep carriage in line with track until all of the bearings are on the track. Be careful not to catch the wipers on the edge of the track.
- Re-attach track to arm using six (6) 5/16-18 hex head tapping screws.

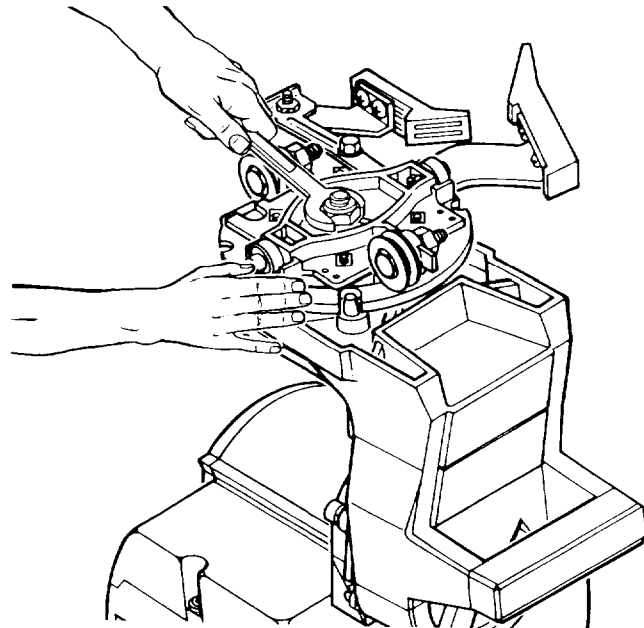
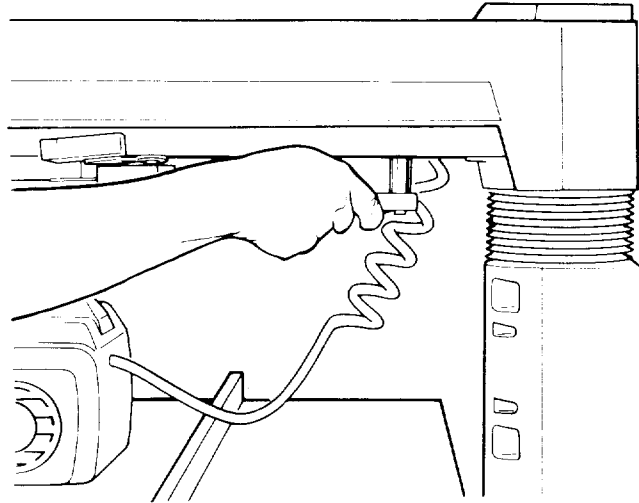

ADJUSTING ARM TO COLUMN

With the miter lock handle unlocked and in the unindexed position the arm should fit snugly to the column tube and not allow any vertical movement. If you can move the end of the arm up and down and adjustment is needed.

- With a #2 phillips screwdriver remove two screws and the rear arm cover as illustrated.
- With a 9/16 inch wrench or socket tighten evenly the top two 3/8-16 hex head tapping screws. The bottom two screws should also be tightened evenly but not as tight as the top screws.
- This adjustment is correct when the arm moves firmly without vertical movement.
- Re-install the rear arm cover.

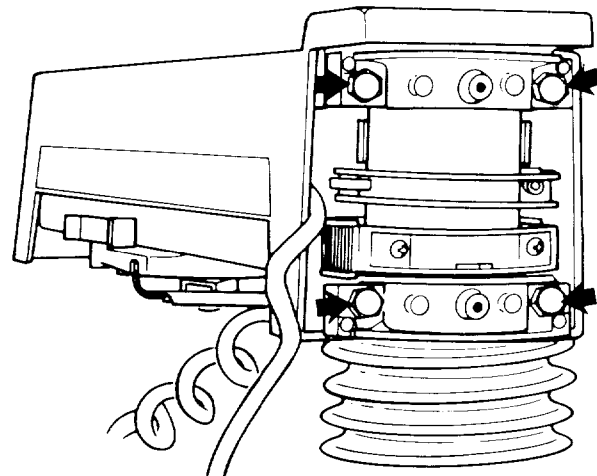

ADJUSTING CARRIAGE BEARINGS

The carriage should roll freely but with some resistance for the entire length of travel. To test for bearing looseness, perform the following steps.

1. Place yoke in either the in-rip or out-rip position.
2. Push the carriage back against the rear stop.
3. Hold the front carriage bearing with your fingers as tight as possible and pull carriage forward at the same time. If you can prevent the bearing from turning an adjustment is required.

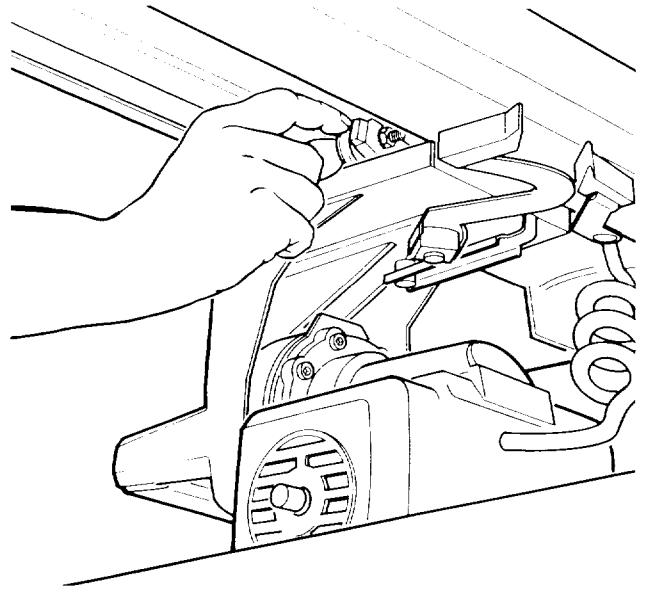

To adjust the carriage bearings perform the following steps.

1. Clean and lubricate the bearing races and the bead on which they ride prior to adjustment.
2. With a 9/16 inch wrench and a 1/2 inch wrench loosen the 5/16-18 hex nuts just enough to permit the eccentric screw to turn.
3. Rotate the eccentric screws a partial turn (left or right) as required to take up looseness. **Both screws should be adjusted an equal amount to maintain blade squareness table in the rip positions.**
4. Hold the head of the eccentric screws in their new position and retighten the nuts.
5. Repeat the test procedure described above and re-adjust if necessary. NOTE: Over tightening the bearings will cause difficult operation and severely reduce the life of the track and bearings.

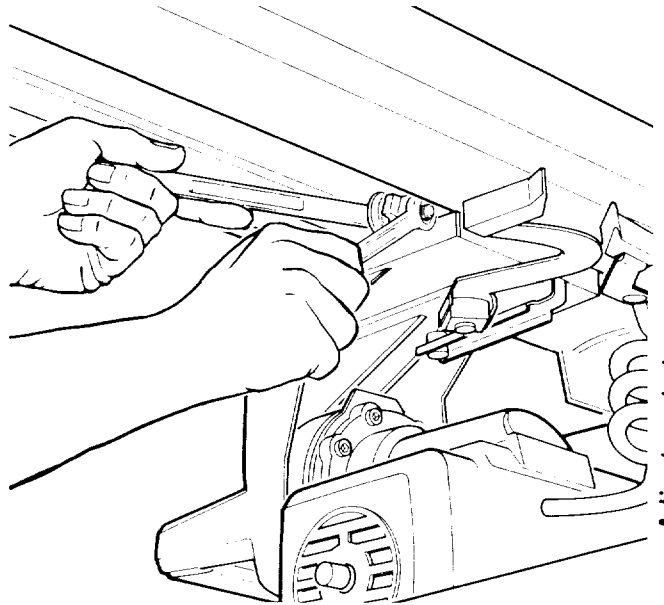

MITER LOCK ADJUSTMENT

The miter lock handle operates adjustable locking bands which lock the arm to the column tube in both indexed and unindexed positions. If the arm can be easily moved by hand when locked in an unindexed position the following adjustment must be made.

1. Move the arm to an unindexed position and leave the miter lock handle in the unlocked position.

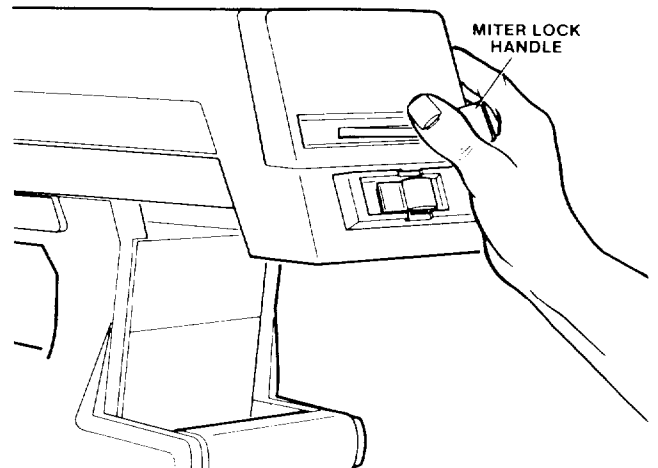

Adjustments to
Compensate for wear

2. With a 3/16 inch hex "L" wrench find the 1/4-20 hex socket cap screw through the hole in the rear arm cover. To tighten turn the wrench clockwise approximately 1/4 turn.
3. Lock the miter lock handle and try again to move the arm. Readjust if necessary.
4. If it becomes extremely difficult to push the miter lock handle into the locked position too much adjustment has been made. Turn the wrench counterclockwise one half the amount of the last adjustment and try again to lock the arm.

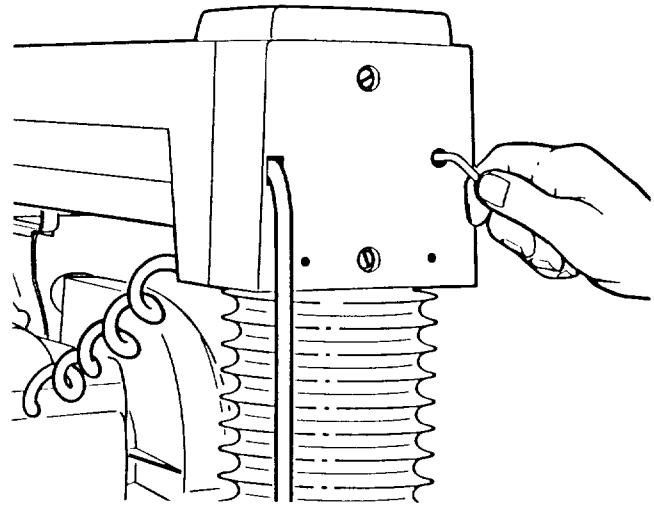

RIP LOCK ADJUSTMENT

The rip lock handle locks the carriage in any position along the length of the track. If the carriage can be easily moved by pushing and pulling on the yoke handle when the rip lock handle is in the locked position an adjustment is required.

1. Hold the rip lock handle in the unlocked position and with a 7/16 inch wrench tighten the 1/4-20 hex lock nut 1/4 turn as illustrated.
2. Lock the rip lock handle and try again to move the carriage. Make additional adjustments if necessary.
3. Now place the rip lock handle in the unlocked position and move the carriage back and forth from stop to stop. If the carriage is difficult to move at any point or you can feel the rip lock dragging on the track the adjustment is too tight. Loosen the hex nut one half the amount of the last adjustment and try again.

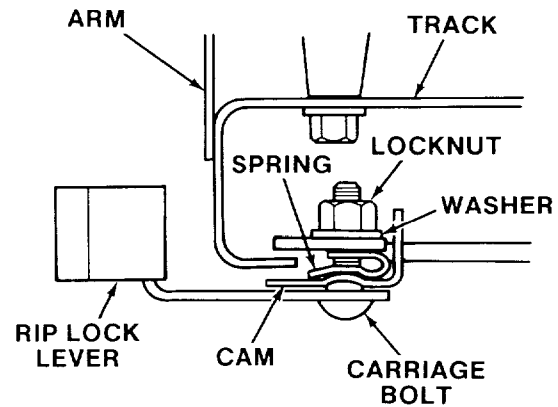

trouble-shooting

HAVE YOU FOLLOWED ALL SIX STEPS OF THE ALIGNMENT PROCEDURE? IF YOU HAVE NOT FOLLOWED THEM IN THEIR PROPER SEQUENCE, YOU CANNOT EXPECT ACCURATE CUTTING RESULTS.

In addition to the proper alignment of your saw, you must also become familiar with the following practices in order to expect the best results.

1. Edge of workpiece which is placed against fence must be as straight as the long side of your framing square.
2. Workpiece must be as flat as the front table board on your saw.
3. There must be no sawdust or other wood chips between the fence and the front table board.
4. There must be no sawdust or other wood chips underneath workpiece or between workpiece and fence.
5. Workpiece must be held tightly against fence and down against the table . . . this is especially important when making angle cuts because the workpiece has a tendency to move.
6. Always use the correct sawblade for the job . . . Always keep it sharp.
7. When making a four sided frame:
 - a. The two side pieces must be exactly the same length.
 - b. The top and bottom pieces must be exactly the same length.
 - c. Always place the same edge of the workpiece against the fence . . . turn the workpiece end for end for the successive cuts and mark a pencil line on the table for gauging the required length.

Deviation from any of the above practices will have an effect on the accuracy of the cuts that you make.

WARNING: REMOVE POWER CORD FROM POWER SOURCE BEFORE TROUBLE SHOOTING.

NOTE: Changing one adjustment will effect another, so it is best to perform all of the alignment procedures when correcting any one problem.

The usual operating "troubles" are listed in the following paragraphs with the necessary corrections listed.

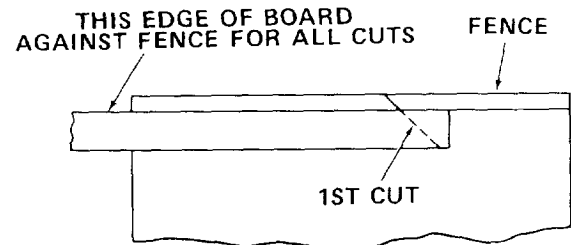

Turn workpiece over end for end . . . keep same edge against fence when making successive cuts.

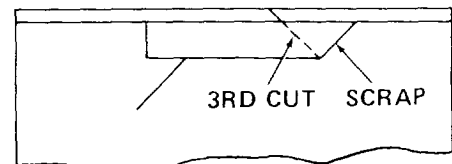
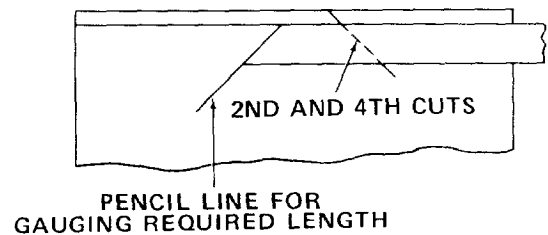

1. RADIAL SAW DOES NOT MAKE ACCURATE 0° or 45° MITER CROSSCUTS.

a. Looseness between column tube and column support.

Align as described in Alignment Procedure Section Step One.

b. Crosscut travel not properly adjusted.

Refer to Step Three in Alignment Procedure Section Squaring Crosscut Travel.

c. Column is Loose in Support.

Refer to Step One in Alignment Procedure.

d. Arm Not Indexing Properly.

Refer to Adjusting Miter Lock Handle in Adjustments to Compensate for Wear section.

e. Carriage Assembly Loose on Arm.

Refer to Carriage Bearing Adjustment in adjustment to Compensate for Wear Sections.

f. Looseness between Yoke and Carriage Assembly.

Refer to "Swivel Lock Handle" adjustment in adjustment to Compensate for Wear Section.

g. Sawdust between Work Piece and Fence.

Keep Front Work Table Clean.

h. Rip Fence Not Straight.

Replace Fence.

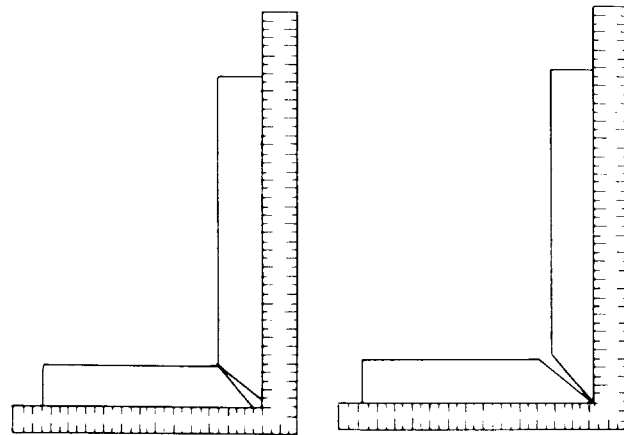
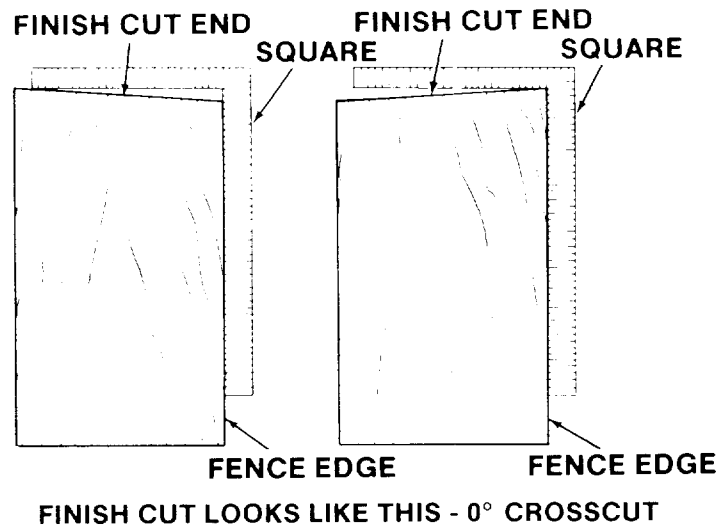

OR LIKE THIS - 45° MITER

2. SAW CUTS AT ANGLE - NOT 90° TO TABLE TOP.

a. Work table is not properly leveled.

Refer to Step Two under Alignment Procedure Section.

b. Blade not square to work table top.

Refer to Step Four in Alignment Procedure Section.

3. BLADE ANGLE (BEVEL) CUTS NOT ACCURATE.

a. Corrective Action is the same as paragraph 2A and B above.

b. Carriage Bearings Loose.

Refer to adjusting carriage bearing in adjustments to compensate for wear section.

c. Bevel Lock Handle Loose.

Refer to Adjustment Bevel Lock Handle in Adjustment to Compensate for Wear Section.

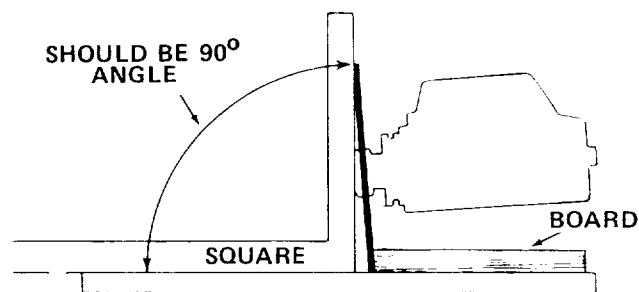

4. SAW KERF (CUT EDGE) OF STOCK ROUGH -TOOTH MARKS LEFT ON EDGE OF SAW KERF.

NOTE: This condition is commonly called "HEEL".

a. Crosscutting or Miter Cutting.

"Heeling" will tend to slide the workpiece along the guide fence, as the cut is being made, and make a square cut almost impossible.

Refer to step 5 under Alignment Procedure Section - "Squaring Blade to Fence."

b. Bevel Crosscutting Or Bevel Ripping.

Refer to Step 5 Under Alignment Procedure Section Vertical Heel Adjusting.

c. Using Improper Blade for Finish Cut Desired.

Use Proper Smooth Cutting Blade.

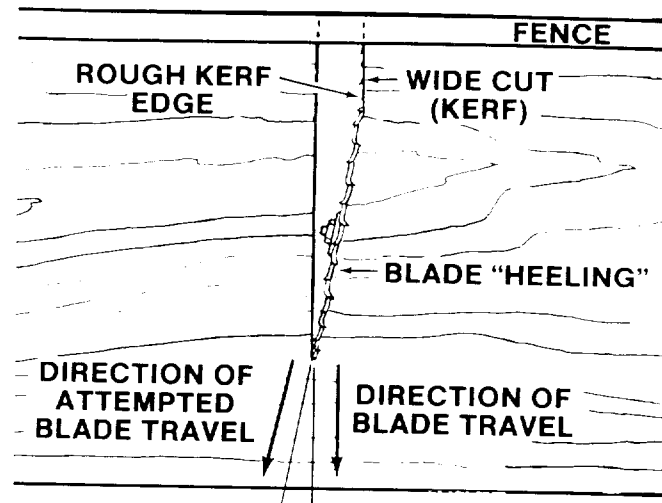

5. WOOD BINDS, SMOKES AND MOTOR SLOWS DOWN OR STOPS WHEN RIPPING.

a. Dull blade or warped board.

Sharpen or replace the saw blade. Do not use severely warped material.

b. Feed rate too fast.

Slow Feed Rate.

c. Saw blade heels.

Check and align as described in Alignment Procedure Section, Step Five.

d. Fence not straight.

Replace fence.

e. Carriage Assembly Loose on Arm.

Refer to adjusting carriage bearings in adjustments to compensate for wear section.

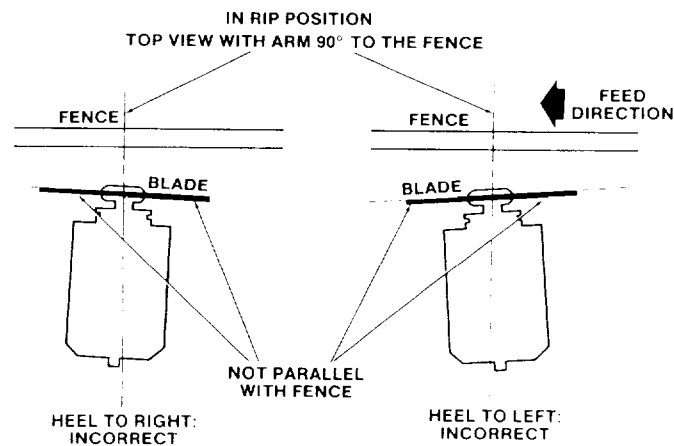

6. BOARD PULLS AWAY FROM FENCE WHEN RIPPING.

a. Saw Blade has heel.

Corrective action is the same as preceding instructions explained in paragraph c.

7. WORKPIECE STRIKES SPREADER WHEN RIPPING.

a. Adjust spreader per instructions in Step Six under "Adjusting Anti-Kickback Pawls and Spreader".

8. SAW DOES NOT TRAVEL SMOOTHLY ON ARM TRACK.

a. Dirty Track.

Clean Track, and Lubricate with Light Grease.

b. Bad Bearing.

Replace Bearing.

c. Worn Track.

Replace Track.

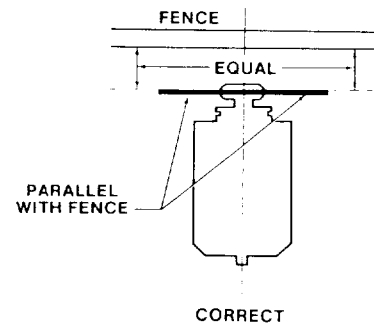

Troubleshooting

9. CLAMPING FORCE NOT SUFFICIENT AT MITER ANGLES OTHER THAN 45°.

a. Miter Lock Handle requires Adjustment.

Refer to Adjusting Miter Lock Handle in Adjustments to Compensate for Wear Section.

10. CLAMPING FORCE NOT SUFFICIENT AT BEVEL ANGLES OTHER THAN 45°.

a. Bevel Lock Handle Requires adjusting.

Refer to Adjusting Bevel Lock Handle in Adjustments to Compensate for Wear Section.

11. DEPTH OF CUT VARIES FROM ONE END OF WORK PIECE TO THE OTHER.

a. Table Top not parallel with Arm.

Refer to Leveling worktable in Step Two Alignment Procedure Section.

12. BLADE TENDS TO ADVANCE THROUGH LUMBER TOO FAST.

a. Dull Blade.

Replace or sharpen blade.

b. Not advancing Saw Blade properly.

Draw Saw Blade across lumber with a slow and steady pull.

MOTOR TROUBLE-SHOOTING CHART

NOTE: Motors used on wood-working tools are particularly susceptible to the accumulation of sawdust and wood chips and should be blown out or "vacuumed" frequently to prevent interference with normal motor ventilation.

TROUBLE	PROBABLE CAUSE	SUGGESTED REMEDY
Motor will not run.	1. Low voltage.	1. Check power line for proper voltage.
Motor will not run and fuses "BLOW".	1. Short circuit in line, cord or plug. 2. Short circuit in motor or loose connections. 3. Incorrect fuses in power line.	1. Inspect line, cord and plug for damaged insulation and shorted wires. 2. Inspect all terminals in motor for loose or shorted terminals or worn insulation on wires. 3. Install correct fuses.
Motor fails to develop full power. (Power output of motor decreases rapidly with decrease in voltage at motor terminals. For example: a reduction of 10% in voltage causes a reduction of 19% in maximum power output of which the motor is capable.)	1. Power line overloaded with lights, appliances and other motors. 2. Undersize wires or circuit too long. 3. General overloading of power company's facilities (in many sections of the country, demand for electrical power exceeds the capacity of existing generating and distribution systems.)	1. Reduce the line load. 2. Increase wire sizes, or reduce length of wiring. 3. Request a voltage check from power company.
Motor overheats.	1. Excessive feed rate when crosscutting or ripping. 2. Improper cooling. (Air circulation restricted through motor due to sawdust, etc.) 3. Saw blade has "heel".	1. Slow down rate of feed. 2. Clean out sawdust to provide normal air circulation through motor. 3. Refer to Alignment Procedure Section of manual Step Five.
Motor starts slowly or fails to come up to full speed.	1. Low Voltage - will not trip starting switch.	1. Correct low voltage condition.
Motor stalls (resulting in blown fuses or tripped circuit breakers).	1. Voltage too low to permit motor to reach operating speed. 2. Fuses or circuit breakers do not have sufficient capacity.	1. Correct the low line voltage condition. 2. Replace fuses or circuit breakers with proper capacity units.
Frequent opening of fuses or circuit breakers.	1. Motor overloaded. 2. Fuses or circuit breakers do not have sufficient capacity.	1. Reduce motor load. 2. Replace fuses or circuit breakers.

maintenance and lubrication

MAINTENANCE

WARNING: FOR YOUR OWN SAFETY, TURN POWER SWITCH "OFF" AND REMOVE PLUG FROM POWER SOURCE OUTLET BEFORE MAINTAINING OR LUBRICATING YOUR SAW.

When you receive your new Craftsman radial saw, it requires no lubrication. The radial saw has been partially aligned and all bearings are lubricated and sealed for life. In time, however, in order to keep your saw in perfect working order and accurate, it will be necessary to lubricate and realign. In fact your radial saw needs more of a cleaning than a lubrication.

Make sure the teeth of the ANTIKICKBACK pawls (key #9 on p. 53) are always sharp. If they become dull they must be replaced. With a 1/2 inch wrench or socket remove the 5/16 hex nut and old pawls. Reassemble new pawls and spreader to antikickback bar. Check spreader for proper alignment and correct if necessary. (Follow procedure on page 22.)

CLEANING

Periodically remove any heavy build-up of sawdust that may accumulate on the saw. The absorbing tendency of sawdust will draw lubricants away from the areas where they are needed. Clean the carriage bearings and tracking surfaces. If packed sawdust and grease accumulate repeatedly on carriage bearings and track inspect the wipers (key #4 p. 51) for wear and replace if necessary. (For access to wipers see "swivel lock adjustment" p. 34.)

CAUTION: To avoid motor damage the motor should be blown out or vacuumed frequently to prevent sawdust build-up which will interfere with normal motor ventilation.

LUBRICATION

Your saw is precision built and should be kept properly lubricated. Before describing the various points which may periodically require lubrication, IT IS MORE IMPORTANT TO FIRST MENTION THE POINTS WHICH SHOULD NOT BE LUBRICATED.

NO LUBRICATION REQUIRED

Do not lubricate the carriage ball bearings or motor bearings as these are sealed ball bearings and require no added lubrication. Do not lubricate between the miter locking rings and the column tube (keys #5 & 9, p. 47).

PERIODICALLY LUBRICATE THESE POINTS

Use SAE No. 10W-30 automotive engine oil and refer to parts list for locations. Apply a few drops of oil along the swivel index pin and the bevel index pin only if the pins have a tendency to stick. Swivel to in-rip or out-rip for easy access to the swivel index pin. Bevel saw to 45° and bevel index pin can be easily accessed behind the yoke as illustrated.

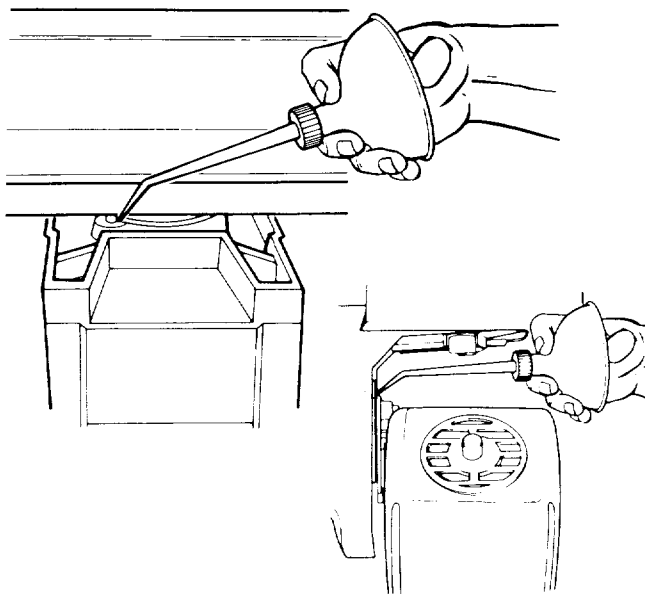

Lubricate the bearing points where the arm attaches to the column tube. With a #2 phillips screwdriver remove two screws and the rear arm cover for access to these points. Be careful not to get lubricant on the locking rings as this will adversely affect the miter locking function.

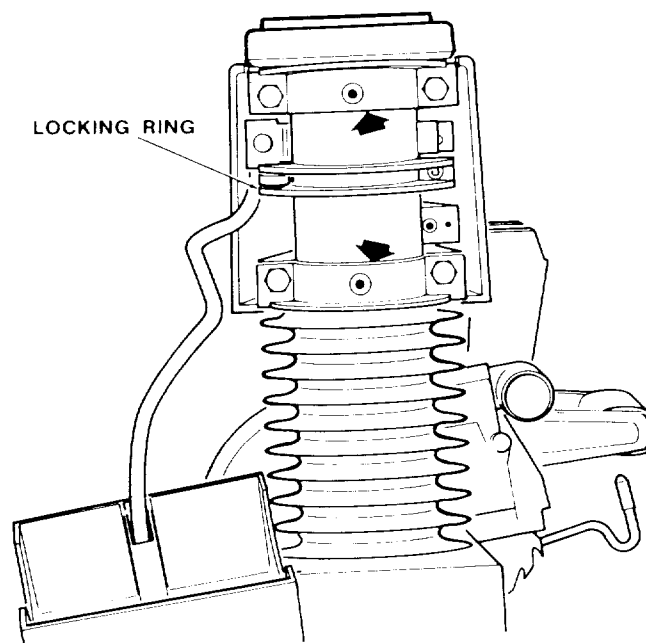

A light film of oil should be wiped on the face of the column tube to lubricate the fit between the column tube and column support. With elevation crank raise arm to upper limit. Completely collapse bellows by pulling down on top flange as illustrated for access to column tube.

The thread on the elevation shaft assembly can be lubricated through the oil hole in the center of the radial arm cap. Lubricate ramp on the swivel index spring.

CAUTION: Excessive oil at any location will attract airborne dust particles and sawdust.

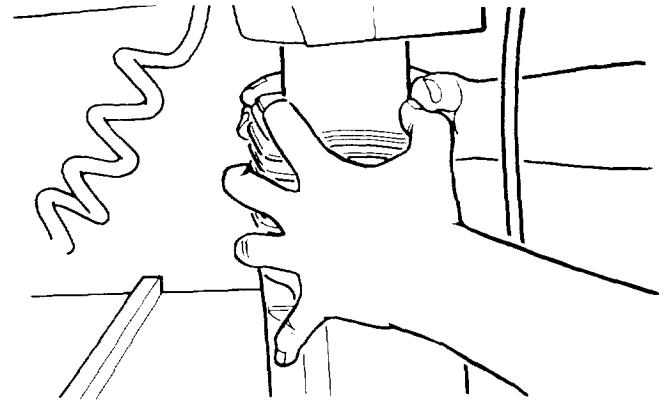

recommended accessories

ITEM	CAT. NO.
Sawblades (10" diameter with with 5/8" hole).....	See Catalog
Caster	9-22254
Sanding Drum.....	9-25246
Drill Chuck and Key	9-2980
Dust Collector	See Catalog
Molding Head Guard 8".....	9-29523
Taper Jig	9-3233
Auxiliary Table Cover	See Catalog
Miter Square	9-32056
Pin Router	9-32765
Extension Table	9-32787

Satin Cut Dado

7"	9-3257
8"	9-3253
8" Carbide.....	9-3264

Standard Cut Dado

8"	9-32475
----------	---------

The above recommended accessories are current and were available at the time this manual was printed.

***NOTE:** This lower retractable guard is designed to provide additional protection to the operator in an axial direction to the sawblade (perpendicular to the plane of the sawblade).

- (a) When NOT in the cut (guards in full down position (touching the table) and carriage in full rear position behind fence):
- (b) When saw is set up to perform 90° crosscut operations (sawblade 90° to table surface and arm in 90° crosscut position).

The lower retractable guard will NOT provide protection to the operator, either crosscutting or ripping:

- (a) Axially when in the cut, because the inner and outer guards ride on top of the fence or workpiece during the cutting operation, exposing the teeth of the sawblade;
- (b) Radially (in a direction in line with the cutting teeth);
- (c) Obliquely (at an angle to the guard and sawblade), between the axial and radial directions.

ITEM	CAT. NO.
Adjustable Dado	
7", 24 Tooth Carbide	9-3261
7", 32 Tooth Carbide	9-3262
7", 16 Tooth Carbide	9-3263
8", 48 Tooth Carbide	9-32708

Molding Heads

7", Bits not included.....	9-3214
7", 27 Piece Set.....	9-3217
7", 15 Piece Set.....	9-3218

Sanding Wheel, 10"	9-22723
Blade Stabilizer.....	9-4952

Cabinet Accessories

Shelf	9-22251
Door.....	9-22252
3 Drawer Set	9-22253

*Lower Retractable Guard
(For 90° Crosscut Only)..... 9-29009

Power Tool Know How Handbook

●Meets OSHA Requirements as of 8-73

Potential risks of injury may be introduced if the lower retractable guard is used for other than 90° crosscut operations, including:

- (a) Becoming caught or jammed in prior kerfs in the fence or table;
- (b) Giving the operator a false sense of security when performing miter, bevel, and rip cuts;
- (c) Jamming when setting-up, and while operating, for bevel and compound miter cuts.
- (d) Jamming for certain in-rip cuts.

The following warning appears on the Lower Outer Guard:

WARNING:
TO AVOID INJURY
SHUT OFF POWER
BEFORE CLEARING A
JAMMED LOWER GUARD

**PARTS LIST FOR CRAFTSMAN 10" RADIAL SAW
MODEL NO. 113.198310**

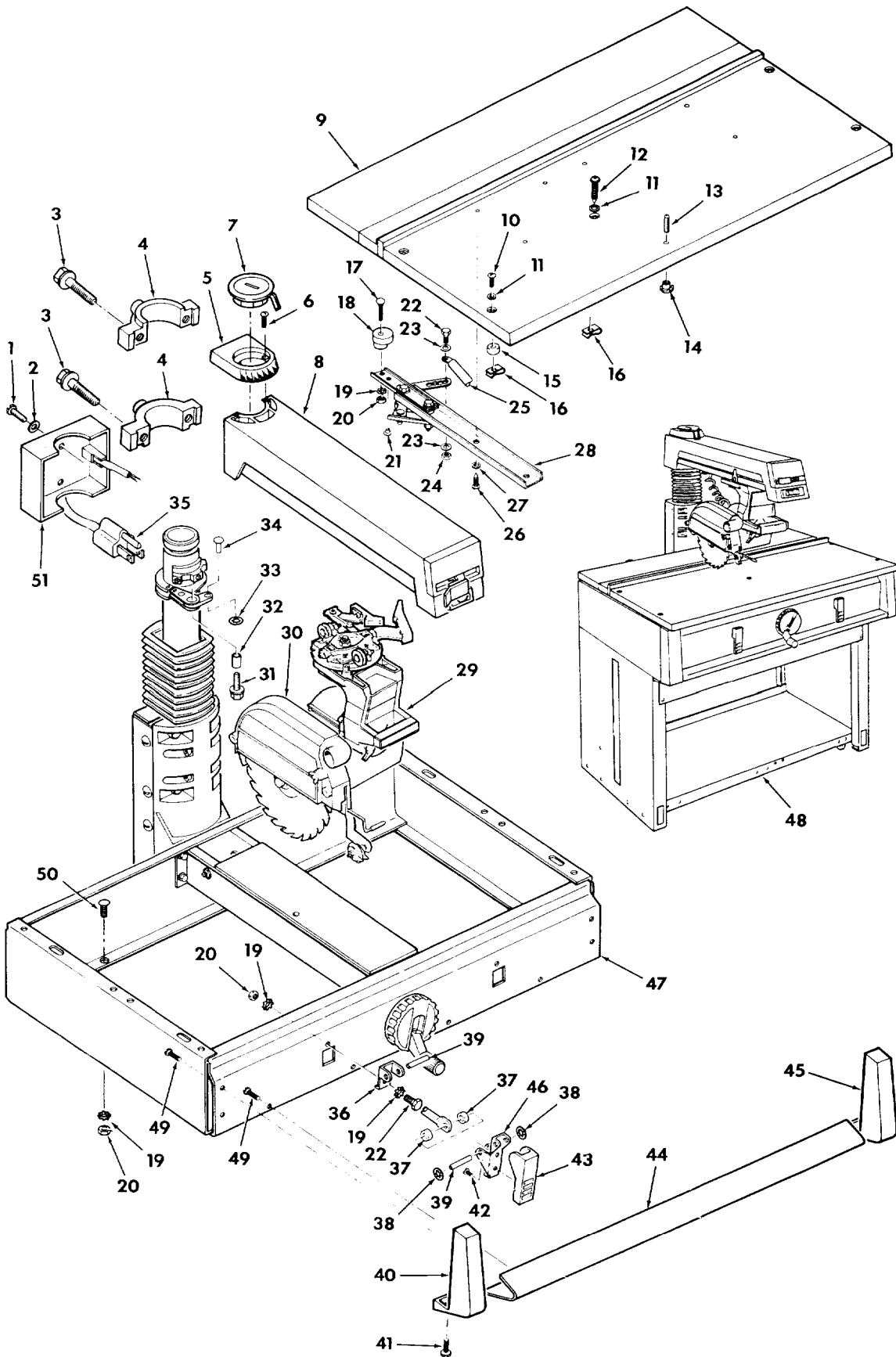

**PARTS LIST FOR CRAFTSMAN 10" RADIAL SAW
MODEL NO. 113.198310**

Always order by Part Number - Not by Key Number

FIGURE 1

Key No.	Part No.	Description
1	STD601103	*Screw, Pan Rec. Type T 10-32 x 3/8
2	STD551010	*Washer, Flat 13/64 x 17/32 x 1/16
3	815857-1	Screw, Hex Washer Hd. 3/8-16 x 1-1/2
4	815649	Bearing, Arm
5	815777	Scale, Miter
6	816333-1	Screw, Pan Rec. Hd. Type "TT" 10-32 x 1/2
7	815778	Indicator, Miter
8	—	Arm Assembly (see Fig. 5)
9	—	Table Boards Set (see Fig. 7)
10	806828-2	Screw, Pan Cross Ty T 1/4-20 x 1-1/4
11	60128	Washer, 17/64 x 5/8 x 1/32
12	815797	Screw, Pan Hd. Rec. Type AB 1/4 x 1-1/4
13	141594-31	Screw, Hex Socket Set 1/4-20 x 1-1/4
14	37384	Nut, Tee
15	815762	Bushing, Rubber
16	815989	Clip, "U" 1/4-20
17	STD532512	*Bolt, Carriage 1/4-20 x 1-1/4
18	815834	Bushing, Eccentric
19	STD551225	*Lockwasher, External 1/4
20	STD541025	*Nut, Hex 1/4-20
21	815990	Button, Table Slide
22	STD522506	*Screw, Hex Hd. 1/4-20 x 5/8
23	STD551012	*Washer 17/64 x 9/16 x 1/32
24	STD541425	*Nut, Lock 1/4-20
25	815832	Rod, Actuator
26	815797	Screw, Pan Hd. Rec. Type AB 1/4 x 1-1/4
27	446188	Washer, 17/64 x 3/4 x 1/16

Key No.	Part No.	Description
28	815939	Rail Assembly, L.H.
	815986	Rail Assembly, R.H.
29	—	Yoke and Motor Assembly (see Fig. 3)
30	—	Guard Assembly (see Fig. 6)
31	815856-1	Screw, Hex Wash Hd. 5/16-18 x 1-1/4
32	815980	Bushing
33	60208	Nut, Push 1/4
34	815774	Rivet 1/4 x 1/2
35	816115	Cord with Plug
36	815764	Bracket, Pivot
37	802279-8	Bushing
38	802955-7	Ring, Push-On
39	62410	Pin
40	815869	Cap, Trim L.H.
41	STD611010	*Screw, Pan Rec, Type "B" No. 10 x 1
42	STD601103	*Screw, Pan Rec. Hd. Type "T" #10-32 x 3/8
43	815753	Cover, Lever
44	815922	Ledge, Trim
45	815881	Cap, Trim R.H.
46	815766	Lever, Lock
47	—	Base and Column Assembly (see Fig. 2)
48	—	Cabinet Assembly (see Fig. 8)
49	815935	Screw Pan Hd. Ty "BT" 1/4 x 1/2
50	805589-5	Screw, Truss Hd. 1/4-20 x 1/2
51	815773	Cover, Rear Arm
	SP5015	Owners Manual (Not Ills.)
	507497	Bag of Loose Parts (Not Ills.)
	507495	Bag of Loose Parts (Not Ills.)

*Standard Hardware Item may be Purchased Locally.

**PARTS LIST FOR CRAFTSMAN 10" RADIAL SAW
MODEL NO. 113.198310**

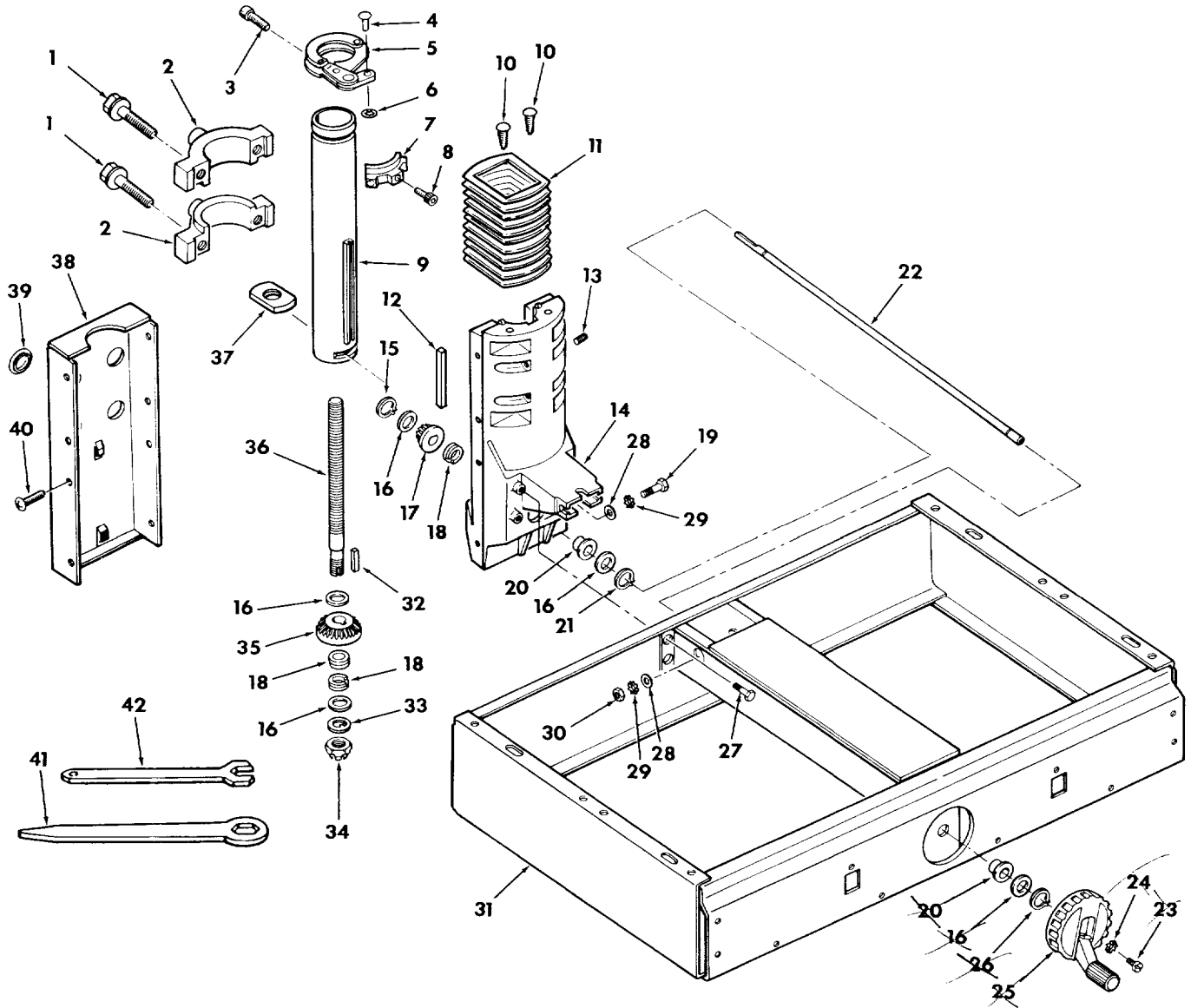

FIGURE 2

**PARTS LIST FOR CRAFTSMAN 10" RADIAL SAW
MODEL NO. 113.198310**

Always order by Part Number - Not by Key Number

FIGURE 2 - BASE AND COLUMN ASSEMBLY

Key No.	Part No.	Description	Key No.	Part No.	Description
1	815857-1	Screw, Hex Washer Hd. 3/8-16 x 1-1/2	21	STD582050	*Ring, Retaining 1/2
2	815649	Bearing, Arm	22	815699	Shaft, Elevating Crank
3	141594-31	*Screw, Socket Hd. Cap 1/4-20 x 1-1/4	23	STD511105	*Screw, Pan Hd. 10-32 x 1/2
4	815774	Rivet, 1/4 x 1/2	24	STD551210	*Lockwasher, External #10
5	815702	Lock Assembly	25	815707	Handwheel
6	60208	Nut, Push 1/4	26	804182	*Ring, Retaining
7	815763	Latch Arm	27	9416187	Screw, Hex Hd. Ty "T" 5/16-18 x 3/4
8	816845-1	Screw, Soc. Hd. Ty T 1/4-20 x 3/4	28	STD551031	*Washer, 21/64 x 3/4 x 1/16
9	815672	Tube	29	STD551131	*Lockwasher, External 5/16
10	330751	Fastener	30	STD541031	*Nut, Hex 5/16-18
11	815754	Bellows, Tube	31	815646-2	Base Assembly
12	815770	Gib, Column Tube	32	805049-1	Key, Square 1/8 x 3/8
13	60531	Screw, Locking Set 1/4-20	33	39711	Washer, Keyed
14	815690	Support, Column Tube	34	STD541450	*Nut, Lock 1/2-13
15	STD581043	*Ring, Retaining 7/16	35	63615	Gear, Bevel
16	63500	Washer, Thrust .502 x .927 x .031	36	815700	Shaft, Elevating
17	63618	Gear, Pinion	37	815771	Nut, Elevation
18	63614	Bearing Lift Shaft	38	815864	Cover, Column Support
19	STD523107	*Screw, Hex Hd. 5/16-18 x 3/4	39	816102	Plug
20	815772	Bushing, Elevation	40	815273	Screw, Truss Rec. Hd. 1/4-20 x 1/2
			41	3540	Wrench, Arbor
			42	63062	Wrench, Shaft

*Standard Hardware Item may be Purchased Locally.

**PARTS LIST FOR CRAFTSMAN 10" RADIAL SAW
MODEL NO. 113.198310**

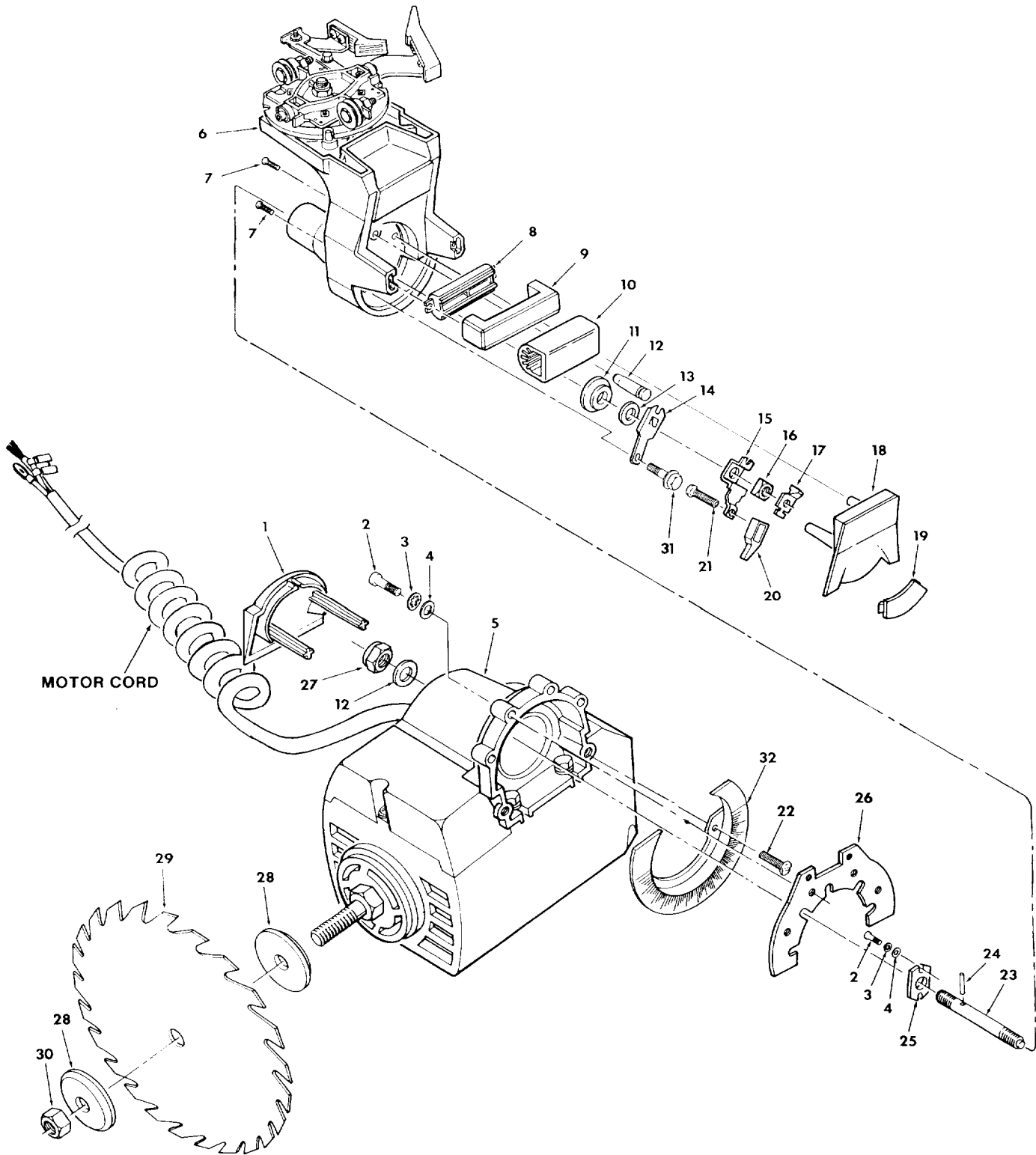

FIGURE 3

**PARTS LIST FOR CRAFTSMAN 10" RADIAL SAW
MODEL NO. 113.198310**

Always order by Part Number - Not by Key Number

FIGURE 3 - YOKE AND MOTOR ASSEMBLY

Key No.	Part No.	Description
1	815803	Cap, Motor Support
2	810214-2	Screw, Low Hd., Cap 1/4-20 x 5/8
3	STD551225	*Lockwasher, Internal 1/4
4	STD551025	*Washer, 17/64 x 9/16 x 1/16
5	816263-1	●Motor
6	—	Yoke Assembly (see Figure 4)
7	808380-6	Screw, Pan Hd., Plastite No. 8 x 1
8	815682	Cover, Handle
9	815683	Handle
10	815776	Grip
11	815678	Washer, Shaft
12	815679-1	Pin, Index
13	805561-10	Washer, .505 x 7/8 x 1/16
14	815791	Spring, Bevel
15	815677	Lever, Bevel Lock
16	815813	*Nut, Square 1/2-13
17	815836	Wedge, Bevel Spring

Key No.	Part No.	Description
18	815685	Cover, Yoke
19	815788	Indicator, Bevel
20	815686	Knob, Bevel Lock
21	808380-2	Screw, Pan Hd., Plastite No. 8 x 3/8
22	STD600803	*Screw, Pan Hd. 8-32 x 3/8
23	815676	Shaft Support
24	455734	Pin, Roll 1/8 x 3/4
25	815674	Plate, Adjustment
26	815673	Plate, Index
27	STD541450	*Nut Lock 1/2-13
28	62498	Collar, Blade
29	9-32668	†Blade, Saw
30	30495	Nut, Shaft
31	9420474	Screw, Hex Hd. Ty "T" 10-32 x 1/2
32	815800	Scale, Bevel

*Standard Hardware Item may be Purchased Locally.

†Stock Item may be Secured Through the Hardware Department of Most Sears Retail or Catalog Order Houses.

●Any attempt to repair this motor may result in unit misalignment and create a HAZARD unless repair is done by a qualified service technician. Do not loosen the three screws holding the motor support to the motor. This assembly is factory aligned. Repair service is available at your nearest Sears Store.

**PARTS LIST FOR CRAFTSMAN 10" RADIAL SAW
MODEL NO. 113.198310**

Always order by Part Number - Not by Key Number

FIGURE 4 - YOKE ASSEMBLY

Key No.	Part No.	Description
1	810214-3	Screw, Low Hd. Cap 5/16-18 x 7/8
2	STD315485	*Bearing, Ball .3150 I.D.
3	STD551031	*Washer, 21/64 x 5/8 x 1/32
4	815808	Wiper, Track
5	815805	Support Indicator
6	815806	Indicator Rip
7	159572-98	Screw, Hex Wash Ty "T" 8-32 x 1/4
8	815689	Carriage
9	STD551062	*Washer, .630 x 1-1/8 x 3/32
10	815817	Nut, Sq. Lock
11	STD541462	*Nut, Lock 5/8-11
12	62636	Nut, Sq. 1/4-20
13	815693	Bracket, Rip Lock
14	STD541425	*Nut, Lock 1/4-20
15	273229	Screw, Hex Hd. Type "T" 1/4-20 x 1/2
16	816497	Spring, Rip Lock
17	815671	Cam, Rip Lock
18	815804	Knob, Rip Lock
19	815692	Lever, Rip Lock
20	STD532507	*Bolt, Carriage 1/4-20 x 3/4
21	808380-2	Screw, Pan Hd., Plastite No. 8 x 3/8

Key No.	Part No.	Description
22	STD541231	*Nut, Hex Jam 5/16-18
23	STD551131	*Lockwasher, External 5/16
24	815691	Ring, Yoke Index
25	STD551012	*Washer, 17/64 x 7/16 x 1/32
26	815798	Lockwasher, High Collar 1/4
27	810214-2	Screw, Low Hd., Cap 1/4-20 x 5/8
28	815645	Yoke
29	815681	Knob, Swivel Lock
30	STD510803	*Screw, Pan Rec. Hd. 8-32 x 3/8
31	815849	Lever, Swivel
32	109529	Nut, Square 5/8-11
33	815679	Pin, Index
34	815680	Spring, Swivel
35	9420474	Screw, Hex Type "T" 10-32 x 3/8
36	815694	Stud, Yoke Clamp
37	STD551031	*Washer, 21/64 x 3/4 x 1/16
38	63777	Bearing, Carriage
39	60438	Washer, No. 2 Carriage Bearing
40	815807	Screw, Eccentric

*Standard Hardware Item may be Purchased Locally.

**PARTS LIST FOR CRAFTSMAN 10" RADIAL SAW
MODEL NO. 113.198310**

Always order by Part Number - Not by Key Number

FIGURE 5 - ARM ASSEMBLY

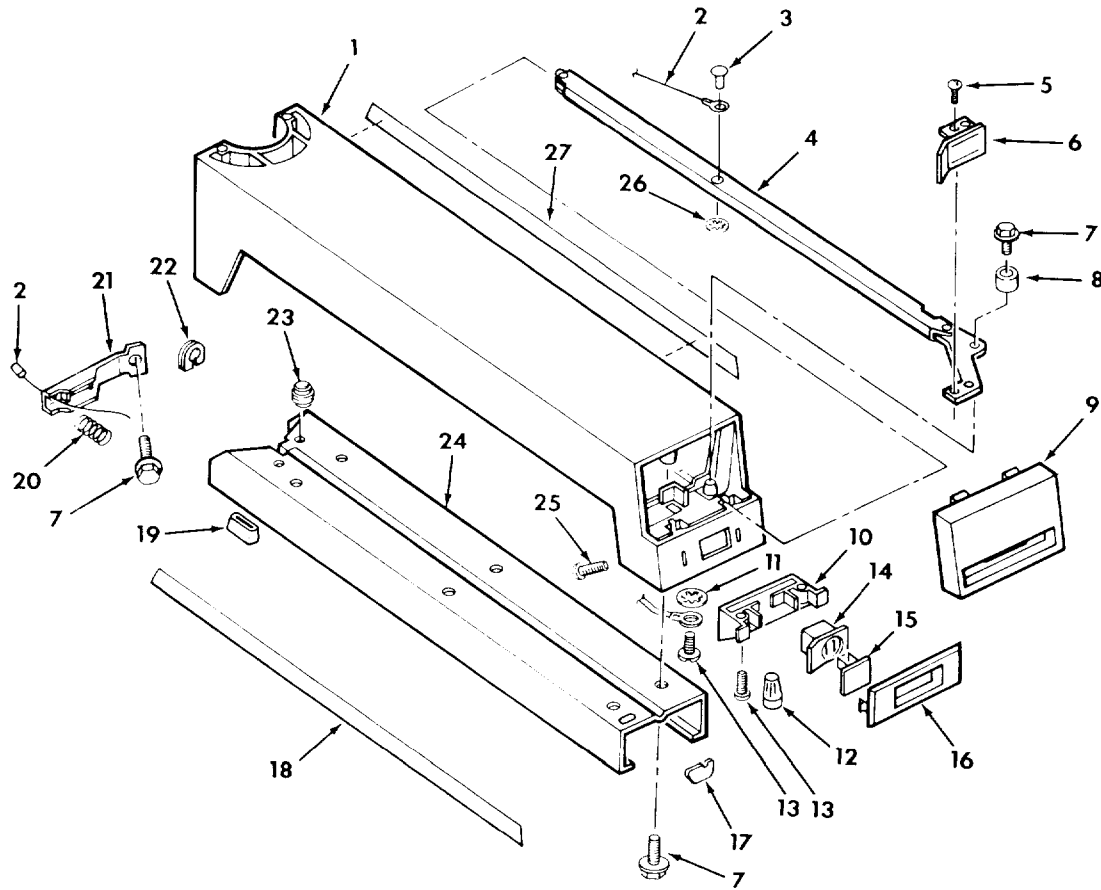

Key No.	Part No.	Description
1	815688	Arm, Radial
2	815809	Cable
3	815774	Rivet, 1/4 x 1/2
4	815790	Actuator Assembly
5	STD601103	*Screw, Pan Rec. Type "T" 10-32 x 3/8
6	815703	Knob, Miter Lock
7	815856	Screw, Hex Washer Hd. 5/16-18 x 3/4
8	815779	Bushing
9	815716	Trim, Arm
10	815704	Housing, Switch
11	STD551208	*Lockwasher, Internal #8
12	803709	Connector, Wire
13	STD600803	*Screw, Pan Rec. Hd. Type "T" 8-32 x 3/8

Key No.	Part No.	Description
14	816113	Switch, Locking
15	815863	Key, Switch
16	815976	Bezel, Switch
17	815938	Pad, Guard
18	815786	Label, Trim L.H.
19	816178	Sleeve, Rubber
20	815867	Spring, Compression
21	815708	Spring, Miter Lock
22	815868	Relief, Strain
23	37818	Relief, Strain
24	815670	Arm, Carriage Support
25	60419	Screw, Pan Rec. Hd. Plastite #8 x 1/2
26	60297	Push Nut, 1/4
27	815785	Label, Trim R.H.

*Standard Hardware Item may be Purchased Locally.

**PARTS LIST FOR CRAFTSMAN 10" RADIAL SAW
MODEL NO. 113.198310**

Always order by Part Number - Not by Key Number

FIGURE 6 - GUARD ASSEMBLY

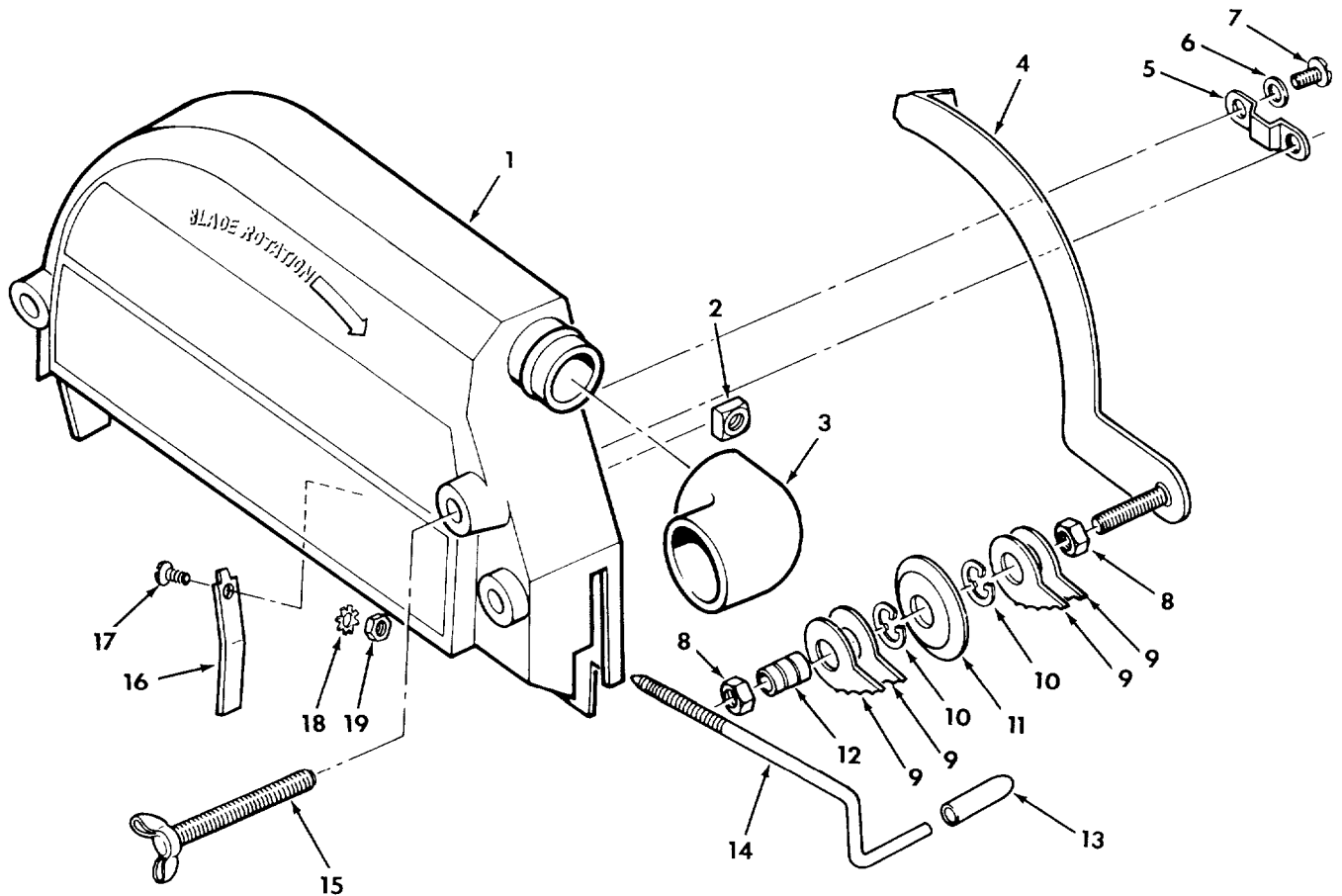

Key No.	Part No.	Description
1	816264	Guard
2	120399	*Nut, Square 5/16-18
3	63258	Elbow, Dust
4	63541	Bar, Anti-Kickback
5	815816	Guide, Anti-Kickback
6	STD551010	*Washer, 13/64 x 5/8 x 1/32
7	STD601103	*Screw, Pan Hd.
8	STD541231	*Nut, Hex Jam 5/6-18
9	815815	Pawl

Key No.	Part No.	Description
10	STD581050	*Ring, Retaining
11	63270	Spreader
12	816341	Bearing (Includes Key #10)
13	60435	Grip
14	816070	Screw, Guard Clamp
15	166785-3	Screw, Wing 5/16-18 x 2-3/4
16	63538	Clamp, Guard
17	STD510805	*Screw, Pan Hd. 8-32 x 1/2
18	STD551208	*Lockwasher, External No. 8
19	STD541008	*Nut, Hex 8-32

*Standard Hardware Item may be Purchased Locally.

**PARTS LIST FOR CRAFTSMAN 10" RADIAL SAW
MODEL NO. 113.198310**

Always order by Part Number - Not by Key Number

FIGURE 7 - TABLE ASSEMBLY

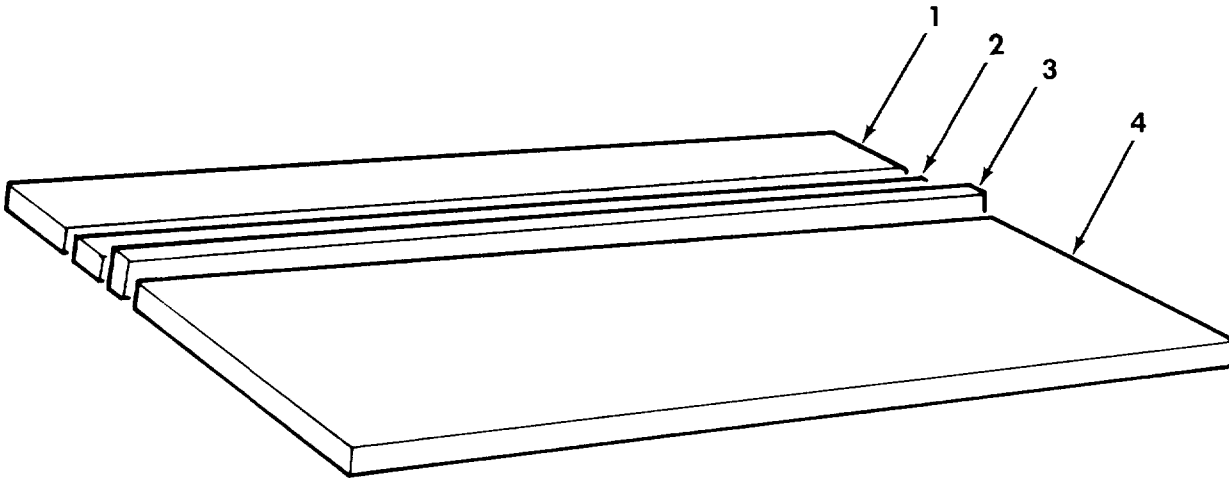

Key No.	Part No.	Description
1	815757	Table, Rear
2	815755	Table Spacer
3	815758	Fence, Rip
4	815756	Table, Front

*Standard Hardware Item may be Purchased Locally.

PARTS LIST FOR CRAFTSMAN 10" RADIAL SAW MODEL NO. 113.198310

Always order by Part Number - Not by Key Number

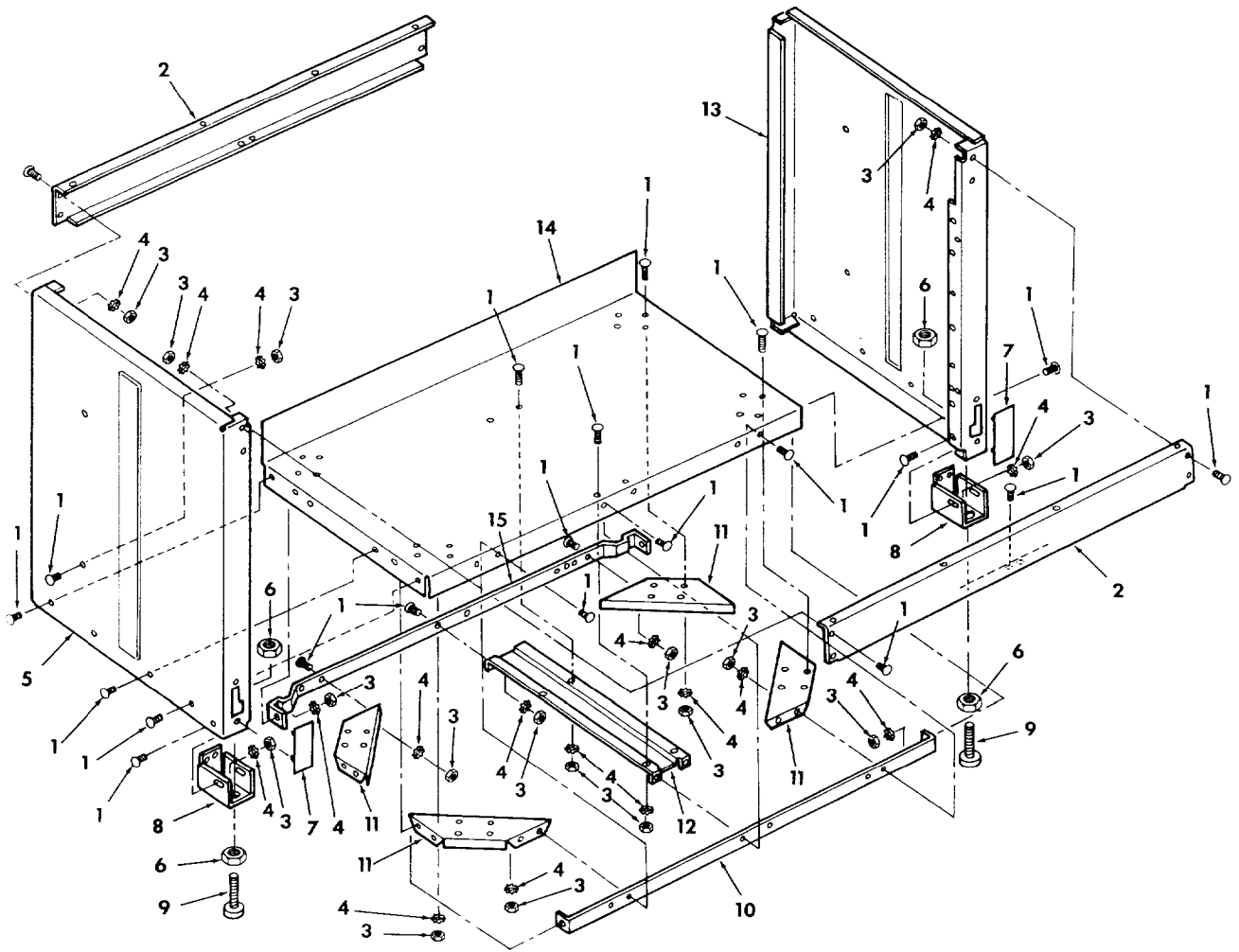

FIGURE 8 - CABINET ASSEMBLY

Key No.	Part No.	Description
1	805589-5	Screw, Truss Hd. 1/4-20 x 1/2
2	815898	Skirt
3	STD541025	*Nut, Hex 1/4-20
4	STD551225	*Lockwasher, External 1/4
5	815905	Panel, L.H. Side
6	STD541250	*Nut, Hex Jam 1/2-13
7	816111	Cover
8	815941	Spacer

Key No.	Part No.	Description
9	803835	Foot, Leveling
10	815942	Stiffener, Shelf
11	815993	Support, Caster
12	815991	Support, Under
13	815906	Panel, R.H. Side
14	815889	Shelf, Lower
15	816336	Stiffener - Shelf Rear

*Standard Hardware Item may be Purchased Locally.

SEARS

**owners
manual**

SERVICE

**MODEL NO.
113.198310**

**10" RADIAL SAW
WITH 44" CABINET**

**HOW TO ORDER
REPAIR PARTS**

10-INCH RADIAL SAW

Now that you have purchased your 10-inch radial saw, should a need ever exist for repair parts or service, simply contact any Sears Service Center and most Sears, Roebuck and Co. stores. Be sure to provide all pertinent facts when you call or visit.

The model number of your 10-inch radial saw will be found on a plate attached to your saw, on the backside of the base.

WHEN ORDERING REPAIR PARTS, ALWAYS GIVE THE FOLLOWING INFORMATION:

PART NUMBER

PART DESCRIPTION

MODEL NUMBER

NAME OF ITEM

113.198310

10-INCH RADIAL SAW

All parts listed may be ordered from any Sears Service Center and most Sears stores. If the parts you need are not stocked locally, your order will be electronically transmitted to a Sears Repair Parts Distribution Center for handling.

Sold by SEARS, ROEBUCK AND CO., Chicago, IL. 60684 U.S.A.