

Save This Manual
For Future Reference

SEARS

**owner's
manual**

**MODEL NO.
113.232210**

**JOINTER/PLANER WITH
LEGS AND MOTOR**

Serial
Number _____

Model and serial numbers
may be found on the back-
side of the jointer base.
You should record both
model and serial number in
a safe place for future use.

**FOR YOUR
SAFETY:
READ ALL
INSTRUCTIONS
CAREFULLY**

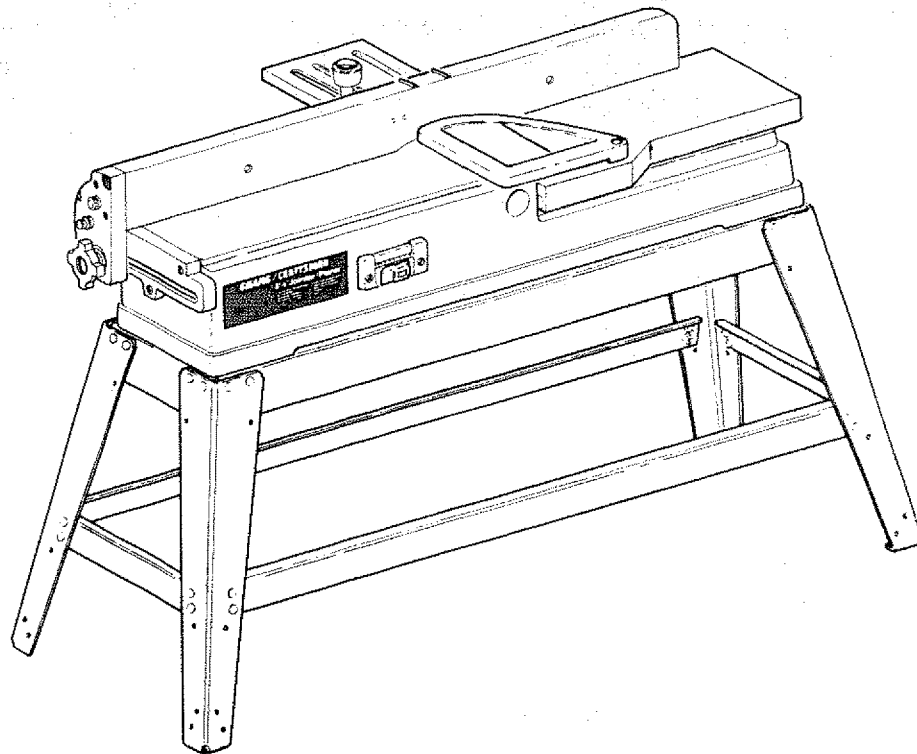

SEARS / CRAFTSMAN®

Contractor

6-1/8-INCH JOINTER-PLANER

- assembly
- operating
- repair parts

Sold by SEARS, ROEBUCK AND CO., Chicago, IL 60684 U.S.A.

Part No. SP5447

Printed in Taiwan

FULL ONE YEAR WARRANTY ON JOINTER/PLANER

If within one year from the date of purchase, this Craftsman Jointer/Planer fails due to a defect in material or workmanship, Sears will repair it, free of charge.

WARRANTY SERVICE IS AVAILABLE BY SIMPLY CONTACTING THE NEAREST SEARS SERVICE CENTER/DEPARTMENT THROUGHOUT THE UNITED STATES.

This warranty applies only while this product is used in the United States.

This warranty gives you specific legal rights, and you may also have other rights which vary from state to state.

SEARS, ROEBUCK AND CO., Dept. 698/731A, Sears Tower, Chicago, IL 60684

GENERAL SAFETY INSTRUCTIONS FOR POWER TOOLS

- 1. KNOW YOUR POWER TOOL**
Read and understand the owner's manual and labels affixed to the tool. Learn its application and limitations as well as the specific potential hazards peculiar to this tool.
- 2. GROUND ALL TOOLS**
This tool is equipped with an approved 3-conductor cord and a 3-prong grounding type plug to fit the proper grounding type receptacle. The green conductor in the cord is the grounding wire. Never connect the green wire to a live terminal.
- 3. KEEP GUARDS IN PLACE**
In working order, and in proper adjustment and alignment.
- 4. REMOVE ADJUSTING KEYS AND WRENCHES**
Form habit of checking to see that keys and adjusting wrenches are removed from tool before turning it on.
- 5. KEEP WORK AREA CLEAN**
Cluttered areas and benches invite accidents. Floor must not be slippery due to wax or sawdust.
- 6. AVOID DANGEROUS ENVIRONMENT**
Don't use power tools in damp or wet locations or expose them to rain. Keep work area well lighted. Provide adequate surrounding work space.
- 7. KEEP CHILDREN AWAY**
All visitors should be kept a safe distance from work area.
- 8. MAKE WORKSHOP CHILD-PROOF**
With padlocks, master switches, by removing starter keys, or storing tools where children can't get them.
- 9. DON'T FORCE TOOL**
It will do the job better and safer at the rate for which it was designed.
- 10. USE RIGHT TOOL**
Don't force tools or attachment to do a job it was not designed for.
- 11. WEAR PROPER APPAREL**
Do not wear loose clothing, gloves, neckties, or jewelry (rings, wrist watches) to get caught in moving parts. NONSLIP footwear is recommended. Wear protective hair covering to contain long hair. Roll long sleeves above the elbow.
- 12. USE SAFETY GOGGLES (HEAD PROTECTION)**
Wear safety goggles (must comply with ANSI Z87.1) at all times. Everyday eyeglasses are not safety glasses. They only have impact resistant lenses. Also, use face or dust mask if cutting operation is dusty, and ear protectors (plugs or muffs) during extended periods of operation.
- 13. SECURE WORK**
Use clamps or a vise to hold work when practical. It frees both hands to operate tool.
- 14. DON'T OVERREACH**
Keep proper footing and balance at all times.
- 15. MAINTAIN TOOLS WITH CARE**
Keep tools sharp and clean for best and safest performance. Follow instructions for lubricating and changing accessories.
- 16. DISCONNECT TOOLS**
Before servicing; when changing accessories such as blades, bits, cutters, etc.
- 17. AVOID ACCIDENTAL STARTING**
Make sure switch is in "OFF" position before plugging in.
- 18. USE RECOMMENDED ACCESSORIES**
Consult the owner's manual for recommended accessories. Follow the instructions that accompany the accessories. The use of improper accessories may cause hazards.
- 19. NEVER STAND ON TOOL OR ITS STAND**
Serious injury could occur if the tool is tipped or if the cutting tool is accidentally contacted. Do not store materials above or near the tool such that it is necessary to stand on the tool or its stand to reach them.
- 20. CHECK DAMAGED PARTS**
Before further use of the tool, a guard or other part that is damaged should be carefully checked to ensure that it will operate properly and perform its intended function. Check for alignment of moving parts, binding or moving parts, breakage of parts, mounting, and any other conditions that may affect its operation. A guard or other part that is damaged should be properly repaired or replaced.
- 21. NEVER LEAVE TOOL RUNNING UNATTENDED**
Turn power off. Don't leave tool until it comes to a complete stop.

additional safety instructions for jointer-planer

Safety is a combination of common sense, staying alert and knowing how your jointer-planer works.

BEFORE USING THE JOINTER-PLANER:

WARNING: TO AVOID MISTAKES THAT COULD CAUSE SERIOUS, PERMANENT INJURY, DO NOT PLUG THE JOINTER-PLANER IN UNTIL THE FOLLOWING STEPS HAVE BEEN SATISFACTORILY COMPLETED.

1. Assembly and alignment.
2. Learn the function and proper use of the on-off switch, fence slide locking handle, cutter guard, depth of cut hand wheel, locks and stops, fence bevel lock handle, outfeed table, infeed table and hold-down/push-blocks.
3. Read and understand all safety instructions and operating procedures throughout the manual.
4. Read the following labels which appear on the jointer-planer:

WARNING

THE STARTING RELAY IN THIS JOINTER IS A GRAVITY SENSITIVE TYPE. NEVER TURN THE POWER ON UNTIL THE JOINTER HAS BEEN MOUNTED ON THE LEG SET AND IS IN UPRIGHT POSITION.

EE 87154

DANGER FOR YOUR OWN SAFETY: Know This Tool!

Read and Understand the Owner's Manual Before Using Machine.

- Wear Safety Goggles complying with ANSI Z87.1.
- Always use Cutter Head Guard. Make sure it springs shut automatically.
- Always use drive guard.
- Use Hold/Down Push Blocks for:
 - a. Jointing material narrower than 3 inches or
 - b. Planing material thinner than 3 inches.
- Use Fence Facings for support when jointing material wider than 4 1/2 inches.

WHEN INSTALLING OR MOVING THE JOINTER-PLANER:

1. To avoid injury from unexpected jointer-planer or workpiece movement:
 - a. Use the jointer-planer indoors on a firm level surface in a well lit area.
 - b. Place the jointer-planer where:
 - i. there is plenty of room for moving the workpiece through the entire cut.
 - ii. no one must stand in line with the wood while planing or jointing it.
 - c. Adjust the jointer-planer so the tables are level and the jointer-planer does not rock.
 - d. Turn off and unplug the jointer-planer before moving it to a new area. To avoid back injury, get help when you need to lift the jointer-planer.
 - e. Bolt the jointer-planer to the floor if it tends to slip, walk, slide or tip over during work like cutting long, heavy boards.

BEFORE EACH USE:

1. Inspect your jointer-planer.

WARNING: THE 2-INCH JOINTER-PLANER PULLEY AND THE 2-1/2 INCH MOTOR PULLEY FURNISHED WILL RUN THE CUTTER HEAD AT ABOUT 4300 RPM WHEN USED WITH A 3450 RPM MOTOR. USE OF DIFFERENT TYPES OF PULLEYS OR MOTORS WILL CHANGE THIS SPEED AND COULD CAUSE JAMMING, BINDING, KICKBACK, THROWN BLADES OR OTHER DANGERS.

- a. If any part of this jointer-planer is missing, or bent, or has failed in any way, or any electrical parts don't work properly, turn the jointer-planer off and unplug the jointer-planer. Replace damaged, missing, or failed parts before using the jointer-planer again.
 - b. Make sure the cutter head turns in the right direction. The top should move toward the infeed table. Call your Sears Service Department for help if the cutter head turns the wrong way.
 - c. Make sure the cutter guard works properly. With the switch off and key removed, pull the cutter guard open and let go. If the guard doesn't smoothly swing closed, contact Sears Service.
 - d. Keep blades sharp. Dull or knicked blades tend to "pound" and chew at the wood, causing kickbacks.
 - e. To avoid injury from thrown pieces, make sure the blades are properly installed and the cutter blade wedge screws are tight.
2. Plan Your Work to protect your eyes, hands, face, ears.
 - a. Before trying a new or little used operation, carefully plan your hand placement. Make sure you have proper hold-down/push-blocks, jigs, fixtures, stops, etc. ready to use.
 - b. Do layout, assembly or set up work on the table only while the jointer-planer is off and the switch key removed.
 - c. Wear safety goggles (not glasses) that comply with ANSI Z87.1 (shown on package). Using any power tool can result in foreign objects being thrown into the eyes, which can result in permanent eye damage. Safety goggles are available at Sears retail catalog stores. Use of glasses or use of goggles not in compliance with ANSI Z87.1 could result in severe injury from breakage of the eye protection.



- d. For dusty operations, wear a dust mask along with safety goggles.
- e. Plan your work to match your workpiece:
 1. To avoid injury from slips or kickbacks:
 - i. Use extra supports (tables, saw horses, etc.) if your workpiece is hard to hold down to the table.
 - ii. Make sure there are no nails or foreign objects in the part of the workpiece to be cut.
 - iii. Never cut FREEHAND. Guide your workpiece solidly against the fence and table top.

Small or thin workpieces can kick back when they tip over on the tables or into the cutter head. To avoid head contact or workpiece kickback:

2. NEVER joint, plane or bevel workpieces shorter than 12 inches.
3. When **Jointing or Beveling**:
 - i. Never joint or bevel workpieces less than 3/4 inch wide or 1/4 inch thick.
 - ii. Always use the hold-down/push-blocks when jointing or beveling wood narrower than 3 inches.
4. When **Planing**:
 - i. Never plane wood thinner than 1/2 inch.
 - ii. Always use hold-down/push-blocks when planing wood thinner than 3 inches.
- f. To avoid risk of hearing damage, wear ear plugs or muffs during extended periods of operation.
- g. To avoid being suddenly pulled into the blade:
 1. Do not wear gloves.
 2. Remove all jewelry and loose clothing.
 3. Tie back long hair.
 4. Roll long sleeves above the elbow.
- h. To avoid injury from accidental starting, always turn switch off, remove switch key and unplug jointer-planer before installing or removing any blade, accessory or attachment, or making any adjustments.
- i. To avoid an electrical shock, make sure your fingers do not touch the metal prongs on the plug when inserting or removing the plug to or from a live outlet.
- j. To avoid burns or other fire damage, never use the jointer-planer near flammable liquids, vapors or gases.

- k. To avoid injury from slips and jams:
 1. Use this jointer-planer to cut only wood.
 2. Plan your hand placement so your fingers will not be anywhere a sudden slip could cause them to slide or fall into the cutter head. When using only one hold-down/push-block to feed the wood, do not put your other hand on the jointer-planer, workpiece, or hold-down/push-block.
 3. Make sure all clamps and locks are tight and there is no excessive play in any parts.
 - l. Adjust the depth of cut to between 1/32 and 1/16 of an inch for best results in most operations. A deep cut makes feeding the wood harder and can cause the wood to kickback. To be sure you will make a depth of cut you planned, always lower the infeed table slightly farther than you wanted. Then, raise the table to the desired depth.
 - m. Before using the jointer-planer, clear the table of all objects not needed to feed the workpiece.
 - n. To avoid injury from unsafe accessories, use only recommended accessories.

WHENEVER JOINTER-PLANER IS RUNNING:

WARNING: DON'T LET FAMILIARITY (GAINED FROM FREQUENT USE OF YOUR JOINTER-PLANER) CAUSE A CARELESS MISTAKE. ALWAYS REMEMBER THAT A CARELESS FRACTION OF A SECOND IS SUFFICIENT TO INFLICT SEVERE INJURY.

1. Make sure bystanders are clear of the tool and workpiece.
2. Before actually cutting with the jointer-planer, let it run for a while. If your jointer-planer makes an unfamiliar noise or if it vibrates excessively, stop immediately. Turn the jointer-planer off. Unplug the jointer-planer. Do not restart until finding and correcting the problem.
3. To avoid injury from slips, stalls or kickback, feed the workpiece into the jointer-planer only fast enough to let the tool cut without bogging down or binding.
4. Before freeing jammed material, turn switch off, remove switch key, unplug the jointer-planer and wait for all moving parts to stop.
5. Never leave the jointer-planer while it is running or before it has come to a complete stop. Remove the switch key and store it in a safe place.

glossary of terms for woodworking

1. **JOINTING** . . . The removal of wood along the edge of a piece of wood so as to make the edge both straight and smooth.
2. **PLANING** . . . Removing wood from the widest surface of a board so as to make it flat and smooth.
3. **WORKPIECE** . . . The piece of wood on which the cutting operation is being performed.
4. **DEPTH OF CUT** . . . A term used to indicate how deep into the workpiece the cutter knives will cut.
5. **INFEED TABLE** . . . The section of the table upon which the workpiece is placed before being pushed into the cutter . . . its height is adjustable which allows the operator to select the depth of cut into the workpiece.
6. **OUTFEED TABLE** . . . The section of a table which supports the workpiece after it passes over the cutter.
7. **HOLD-DOWN/PUSH-BLOCKS** . . . They are required for your own safety . . . they are used to hold thin or narrow workpiece down against the table and fence when planing or jointing.
8. **REVOLUTIONS PER MINUTE (R.P.M.)** . . . The number of turns completed by a spinning object in one minute.
9. **KICKBACK** . . . a kickback occurs when the operator loses control of the workpiece causing it to be kicked back toward him by the rotating cutter knives.
10. **FENCE** . . . attached to the jointer-planer in a more or less vertical position . . . helps support and guide the workpiece as workpiece is pushed across the cutter head.
11. **FREEHAND** . . . trying to use the tool without holding the workpiece firmly against the fence and table. This can let the workpiece twist and kick back.
12. **LEADING END** . . . the end of the workpiece which is pushed into the cutting tool first.
13. **TRAILING END** . . . the workpiece end last cut by the blades.

table of contents

	Page		Page
Guarantee	2	Installing the Fence	17
General Safety Instructions for Power Tools	2	Installing Belt Guard and Sliding Guard	18
Additional Safety Instructions for Jointer/Planer	3	Getting to Know Your Jointer/Planer	20
Glossary of Terms of Woodworking	5	Basic Jointer/Planer Operations	27
Electrical Connections	6	Maintenance	31
Unpacking and Checking Contents	8	Sharpening Cutter Knives	34
Location and Function of Controls	11	Installing (Replacing) Cutter Guard Spring	34
Assembling the Steel Legs	12	Lubrication	35
Installation of Drive Belt	13	Trouble Shooting	36
Mounting the Jointer/Planer	15	Repair Parts	38
Checking Cutter Knives and Screws	16		

electrical connections

POWER SUPPLY

1. Motor Specifications

The A-C motor used in this jointer-planer is a capacitor-start, non-reversible type having the following specifications:

Rated H.P.	1.0
Maximum Developed H.P.	2.0
Voltage	120
Amperes	10.0
Hertz (cycles)	60
Phase	Single
RPM	3450
Rotation of Motor Shaft	Counterclockwise

WARNING: TO AVOID ELECTRICAL HAZARDS, FIRE HAZARDS, OR DAMAGE TO THE TOOL, USE PROPER CIRCUIT PROTECTION. YOUR JOINTER-PLANER IS WIRED AT THE FACTORY FOR 120V OPERATION. CONNECT TO A 120V 15-AMP, BRANCH CIRCUIT AND USE A 15-AMP, TIME DELAY FUSE OR CIRCUIT BREAKER.

IF NOT PROPERLY GROUNDED, THIS POWER TOOL CAN CAUSE ELECTRICAL SHOCK—PARTICULARLY WHEN USED IN DAMP LOCATIONS IN PROXIMITY TO PLUMBING. IF AN ELECTRICAL SHOCK OCCURS, THERE IS ALSO THE POTENTIAL OF A SECONDARY HAZARD SUCH AS YOUR HANDS CONTACTING THE CUTTER KNIVES. NOT ALL OUTLETS ARE PROPERLY GROUNDED. TO AVOID SHOCK OR FIRE, IF POWER CORD IS WORN OR CUT, OR DAMAGED IN ANY WAY, HAVE IT REPLACED IMMEDIATELY.

If you are not sure that your outlet is properly grounded, have it checked by a qualified electrician.

Your unit is for use on 120 volts and has a plug that looks like below.

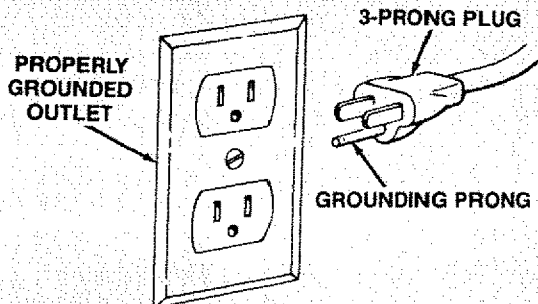

This power tool is equipped with a 3-conductor cord and grounding type plug listed by Underwriters' Laboratories. The ground conductor has a green jacket and is attached to the tool housing at one end and to the ground prong in the attachment plug at the other end.

This plug requires a mating 3-conductor grounded type outlet as shown at the lower left corner of this page.

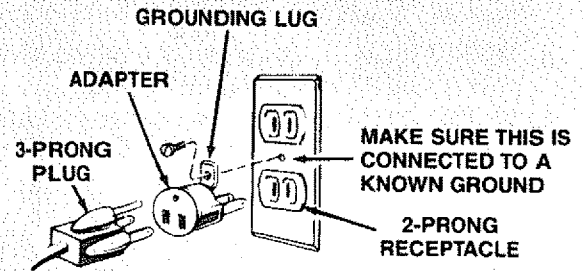

WARNING: TO MAINTAIN PROPER TOOL GROUNDING WHENEVER THE OUTLET YOU ARE PLANNING TO USE FOR THIS POWER TOOL IS OF THE TWO PRONG TYPE, DO NOT REMOVE OR ALTER THE GROUNDING PRONG IN ANY MANNER. USE AN ADAPTER AS SHOWN AND ALWAYS CONNECT THE GROUNDING PRONG TO KNOWN GROUND.

Have a qualified electrician replace the two prong outlet with a properly grounded three prong outlet.

An adapter as shown above is available for connecting plug to 2-prong receptacles. The green grounding lead extending from the adapter must be connected to a permanent ground such as to a properly grounded outlet box.

WARNING: THE ADAPTER ILLUSTRATED IS FOR USE ONLY IF YOU ALREADY HAVE A PROPERLY GROUNDED 2-PRONG RECEPTACLE.

MOTOR SAFETY PROTECTION

CAUTION: To avoid motor damage, this motor should be blown out or vacuumed frequently to prevent sawdust build-up which will interfere with normal motor ventilation.

1. Connect this tool to a 120V, 15-Amp branch circuit with a 15-Amp time delay fuse or circuit breaker. Failure to use the proper size fuse can result in damage to the motor.
2. If the motor fails to start, turn the power switch to the "OFF" position immediately. **UNPLUG THE TOOL.** Refer to the "Motor Trouble-Shooting Chart."
3. Frequent "blowing" of fuses or tripping of circuit breakers may result if:
 - a. **MOTOR IS OVERLOADED**—Overloading can occur if you feed too rapidly into cutter knives.
 - b. **MOTOR CIRCUIT IS FUSED DIFFERENTLY FROM RECOMMENDATIONS**—Always follow instructions for the proper fuse/breaker. Do not use a fuse/breaker of greater capacity without consulting a qualified electrician.

- c. **LOW VOLTAGE**—Although the motor is designed for operation on the voltage and frequency specified on motor nameplate, normal loads will be handled safely on voltages not more than 10% above or below the nameplate voltage. Heavy loads, however, require that voltage at motor terminals equals the voltage specified on nameplate.
4. Most motor troubles may be traced to loose or incorrect connections, overloading, reduced input voltage (such as small size wire in the supply circuit) or to overly long supply circuit wire. Always check the connections, the load and the supply circuit whenever motor fails to perform satisfactorily. Check wire sizes and length with the Wire Size Chart shown to the right.

WIRE SIZES

The use of any extension cord will cause some loss of power. To keep this to a minimum and to prevent overheating and motor burn-out, use the table below to determine the minimum wire size (A.W.G.) extension cord. Use only 3 wire extension cords which have 3 prong grounding type plugs and 3-pole receptacles which accept the tools plug.

CAUTION: For circuits that are farther away from electrical service box, the wire size must be increased proportionately in order to deliver ample voltage to the saw motor.

Length of the Conductor	Wire Sizes Required (American Wire Gauge Number) 120V Lines
0-25 Ft.	No. 16
26-50 Ft.	No. 14
51-100 Ft.	No. 12

unpacking and checking contents

Model 113.232210 Jointer-Planer is shipped complete in one carton and INCLUDES Steel Legs and Motor.

Separate all parts from packing materials and check each one with the illustration and the list of Loose Parts to make certain all items are accounted for, before discarding any packing material.

WARNING: IF ANY PARTS ARE MISSING, DO NOT ATTEMPT TO ASSEMBLE THE JOINTER-PLANER, PLUG IN THE POWER CORD OR TURN THE SWITCH ON UNTIL THE MISSING PARTS ARE OBTAINED AND ARE INSTALLED CORRECTLY.

Remove the protective oil that is applied to all unpainted metal surfaces. Use any ordinary household type grease and spot remover.

WARNING: TO AVOID FIRE OR TOXIC REACTION, NEVER USE GASOLINE, NAPHTHA OR SIMILAR HIGHLY VOLATILE SOLVENTS.

Apply a coat of paste wax to the table.

Wipe all parts thoroughly with a clean, dry cloth.

WARNING: FOR YOUR OWN SAFETY, NEVER CONNECT PLUG TO POWER SOURCE OUTLET UNTIL ALL ASSEMBLY STEPS ARE COMPLETE, AND YOU HAVE READ AND UNDERSTAND THE SAFETY AND OPERATIONAL INSTRUCTIONS.

TABLE OF LOOSE PARTS Model 113.232210 6-1/8 JOINTER

Item	Description	Qty.
A	Jointer Base	1
B	Fence	1
C	Push Blocks	2
D	Sliding Fence Guard	1
E	Belt Guard	1
F	Owner's Manual	1
G	Legs	4
H	Top Side Stiffener	2
I	Bottom Side Stiffener	2
J	Top End Stiffener	2
K	Bottom End Stiffener	2
L	Loose Parts Bag #507711	1
M	Loose Parts Bag #508210	1
N	Loose Parts Bag #508092	1

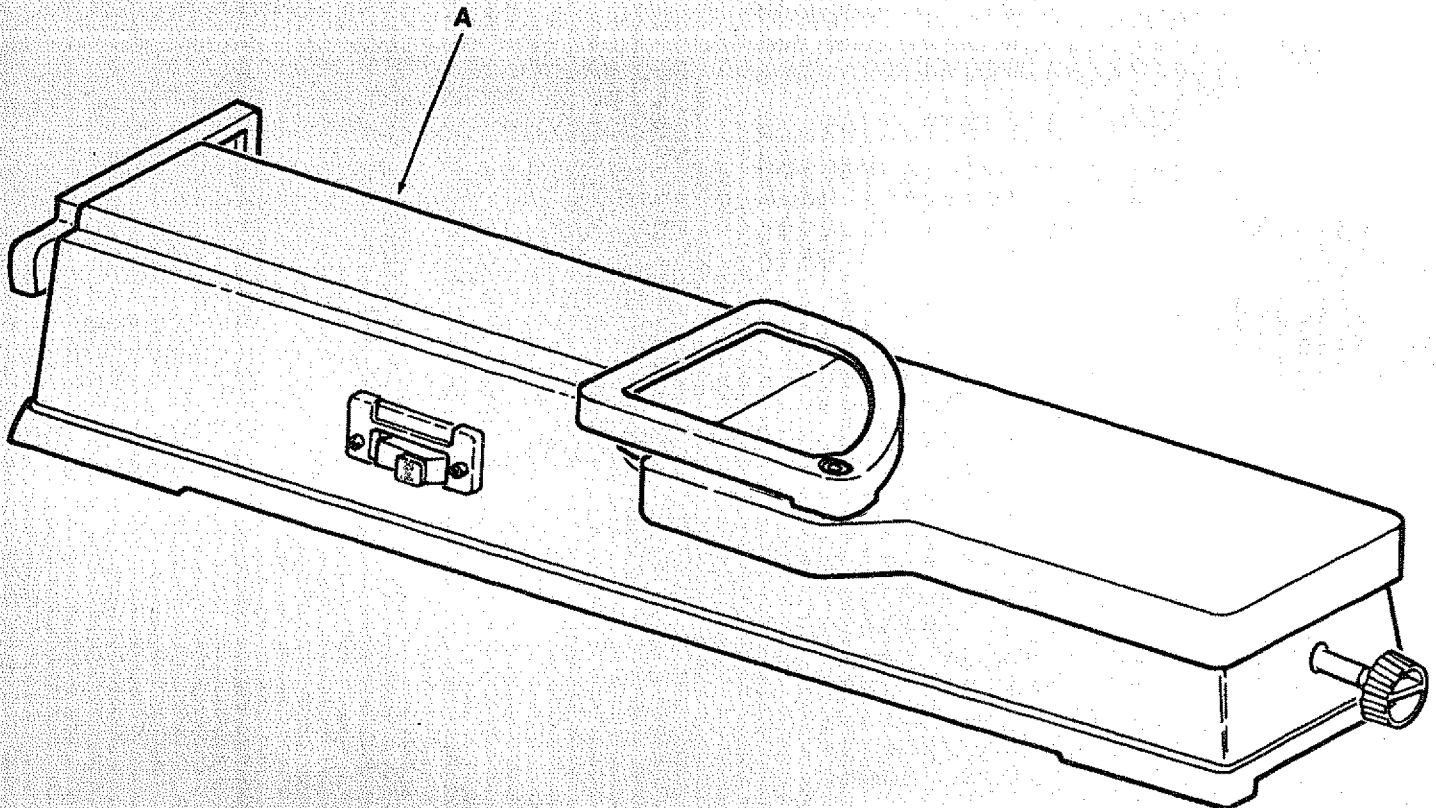

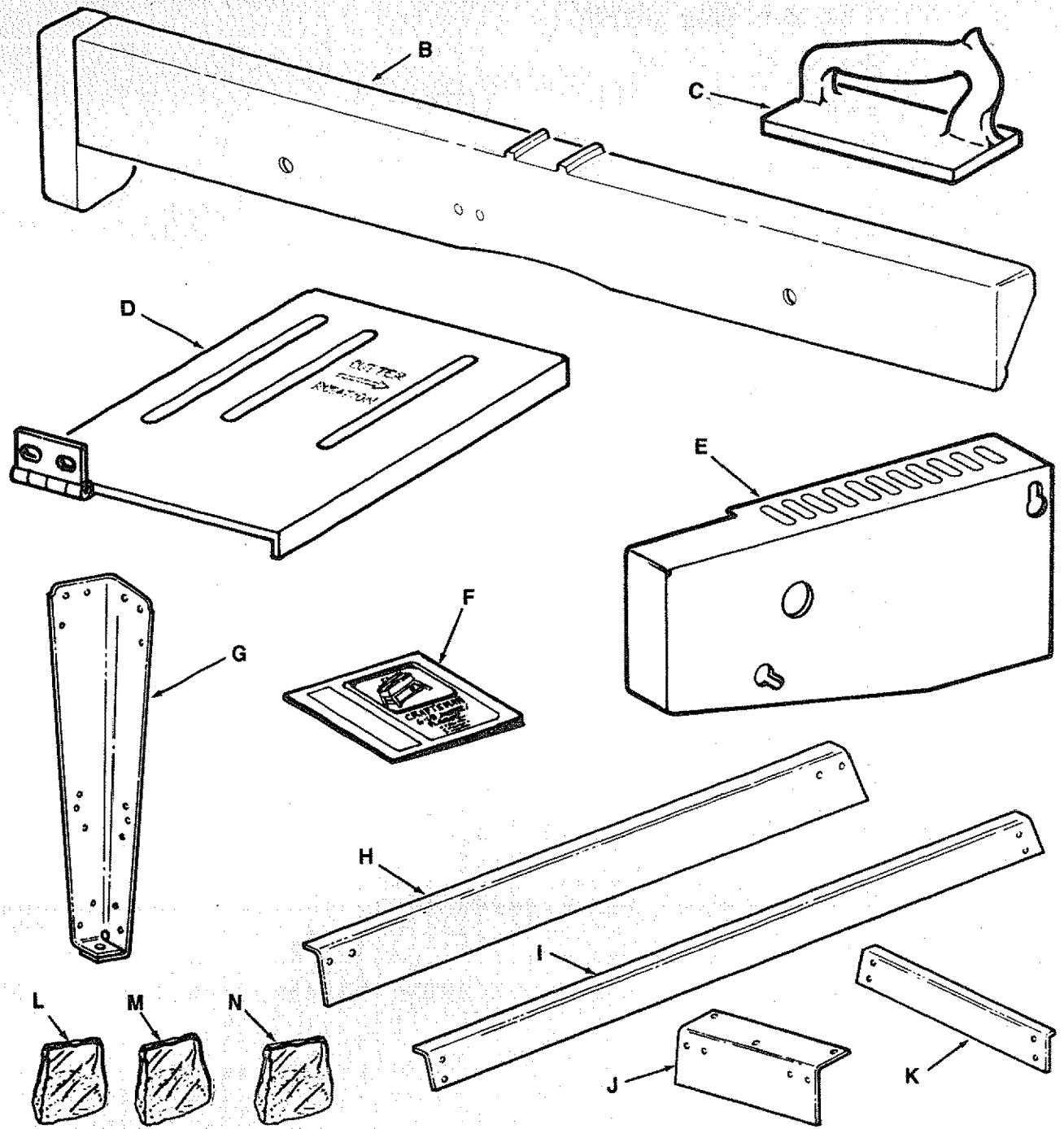

List of Loose Parts in Bag #508210

Item	Description	Qty.
O	"V" Belt	1
P	Siding Guide Rod	1
Q	Pulley	1
R	Lock Knob	1
S	Loose Parts Bag (#508091 and #508093)	2

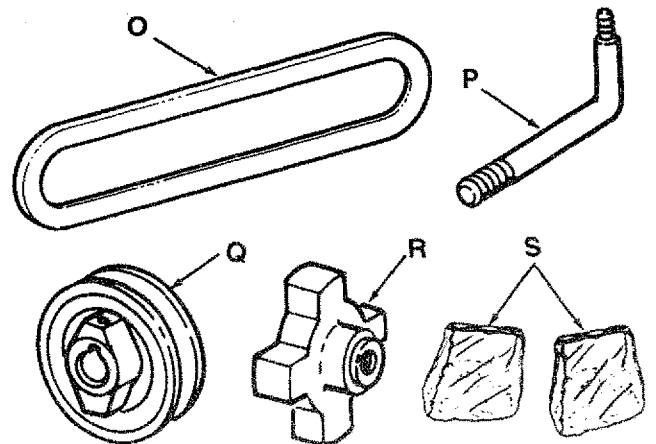

LIST OF LOOSE PARTS IN BAG #507711

Item	Description	Qty.
* A	Leveling Feet	4
* B	Hex Jam Nut 3/8-16	8
* C	Truss Head Screw 1/4-20 x 1/2	32
* D	External Lock Washer 1/4	32
* E	Hex Nut 1/4-20	32
* F	Hex Head Screw 3/8-16 x 3/4	3
* G	Internal Lock Washer 3/8	3

* These parts are shown full size for easy identification.

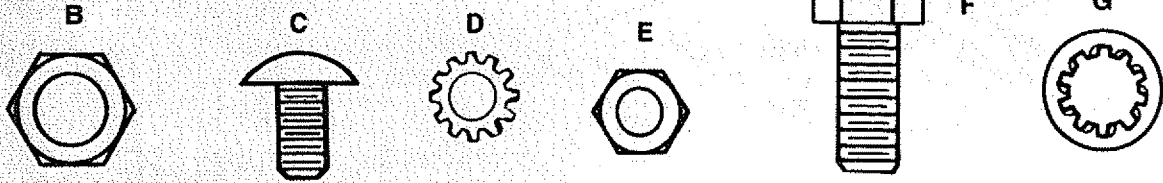
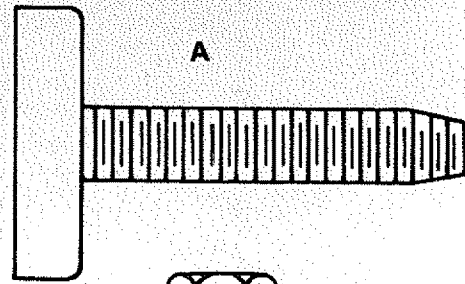

LIST OF LOOSE PARTS IN BAG #508091

Item	Description	Qty.
* H	Spacer	1
* I	Washer 380 x 19/64 x 7/64	1
* J	Retainer	1
* K	Carriage Bolt 3/8-16 x 2-1/2	1

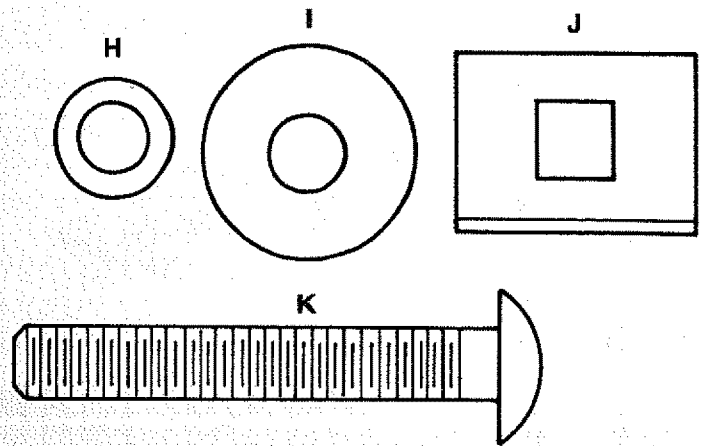

LIST OF LOOSE PARTS IN BAG #508092

Item	Description	Qty.
* L	Switch Key	1

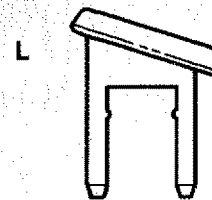

LIST OF LOOSE PARTS IN BAG #508093

Item	Description	Qty.
* M	Rec Pan Screw 10-32 x 2-3/4	2
* N	Sliding Guard Washer	2
* O	Pan Head Screw 10-32 x 1/4	2
* P	Nut Hex Jam 1/2-13	1
* Q	External Lock Washer #10	2
* R	Lock Washer	1
* S	Knob Assembly 1-1/2	1

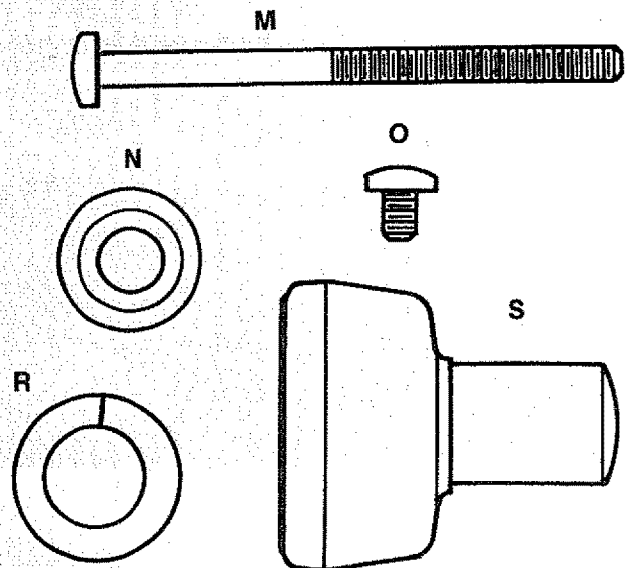
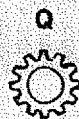
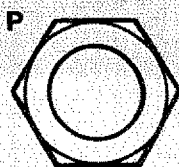

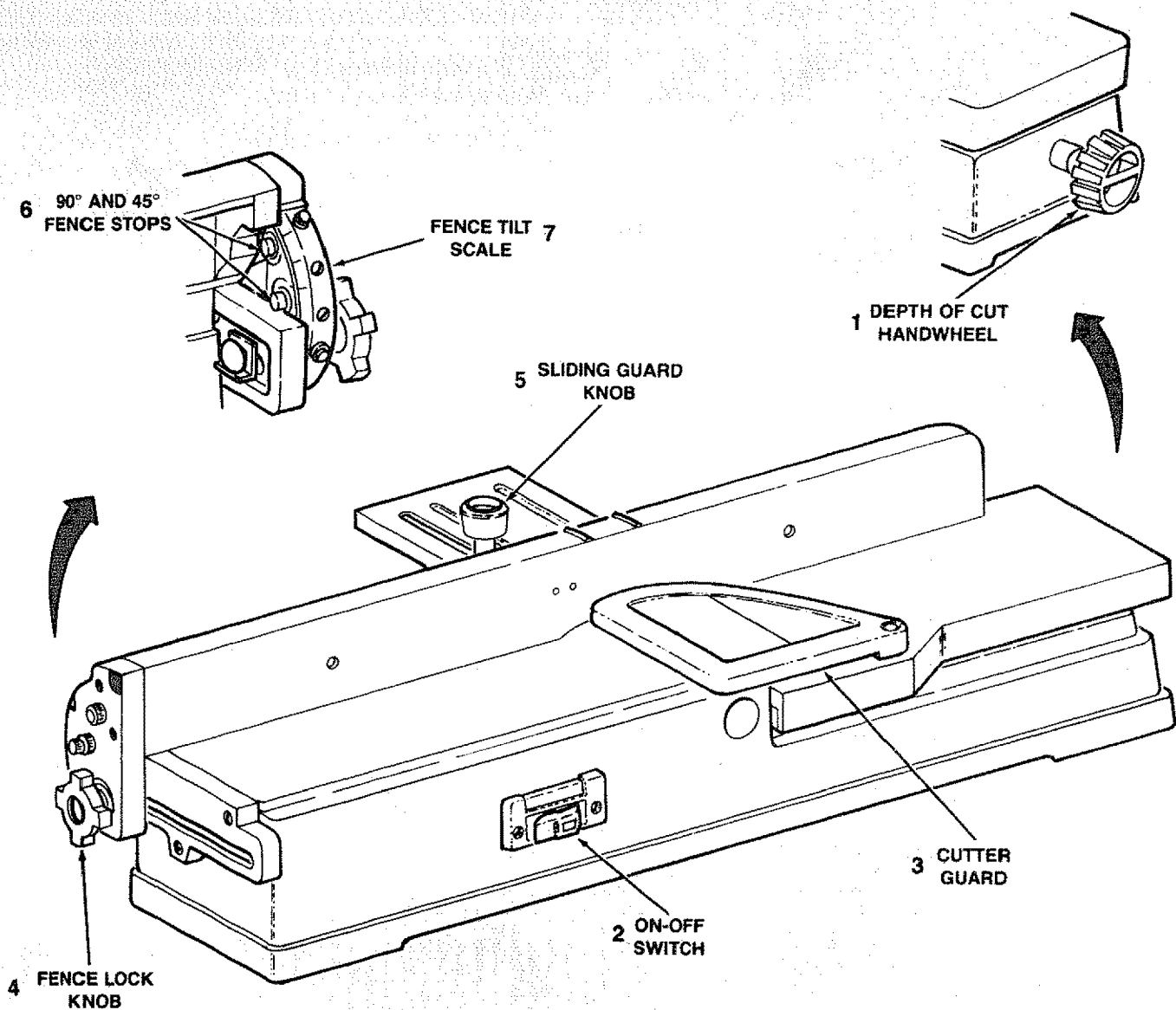

LOCATION AND FUNCTION OF CONTROLS

1. Depth of cut handwheel:

By turning the handwheel you can control how much wood will be removed from the workpiece.

2. On-Off Switch:

Turns the tool on and off.

3. Cutter Guard:

Helps protect the operator from the sharp knives on the cutterhead . . . It is spring loaded so it automatically keeps the cutterhead covered before, during, and after a cutting operation . . . It must always be used.

4. Fence Lock Knob:

Allows the fence to be repositioned and locked at any angle from 45° to 90°. To lock—turn the knob clockwise. To unlock—turn the knob counterclockwise.

5. Sliding Guard Knob:

Allows the fence to be repositioned at any location from the front to the rear of the tables and to be locked at that position. To unlock—turn the knob counterclockwise. To lock—turn the knob clockwise.

6. 90° and 45° Fence Stops:

When adjusted properly, these stops provide a method for quickly moving the fence to a 90° or 45° position from the table.

7. Fence Tilt Scale:

Helps the operator accurately and quickly position the fence at any angle between 45° and 90°.

assembly

TOOLS NEEDED

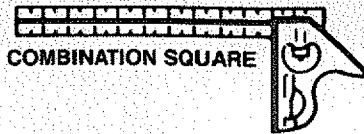
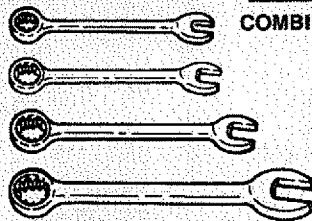

STRAIGHT EDGE OF BOARD 3/4-INCH THICK THIS EDGE MUST BE PERFECTLY STRAIGHT

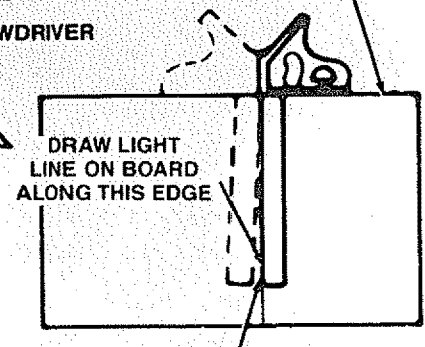

WARNING: ALTHOUGH COMPACT, THE BODY OF THIS TOOL WEIGHS 150 LB. TO AVOID BACK INJURY, GET HELP WHENEVER YOU NEED TO LIFT THE JOINTER PLANER.

ASSEMBLING STEEL LEGS

From the loose parts find four (4) leveling feet, eight (8) 3/8"-16 hex nuts, thirty-two (32) 1/4"-20 x 1/2" truss head screws, thirty-two (32) 1/4" external lock washers, and thirty-two (32) 1/4"-20 hex nuts.

SPECIAL NOTE: When assembling leg set, hand tighten bolts only.

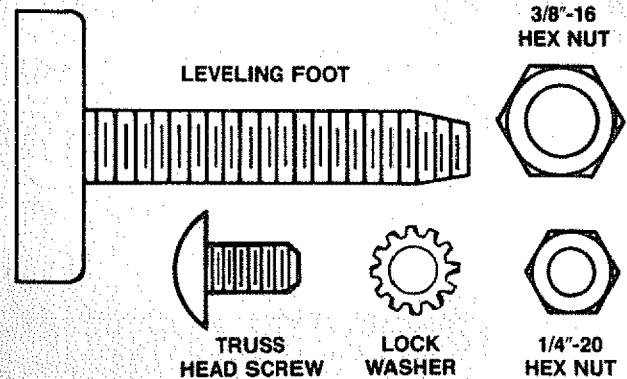

1. Attach the two (2) top side stiffeners and the two (2) bottom side stiffeners to the legs as shown using 1/4" x 20 truss head bolts, 1/4" lock washers, and 1/4" hex nuts. Make sure the top side stiffeners are positioned so they pass over the top surface of the top end stiffeners.

2. Attach the two (2) top end stiffeners and the two (2) bottom end stiffeners to the legs as shown using 1/4" x 20 truss head bolts, 1/4" lock washers, and 1/4" hex nuts.

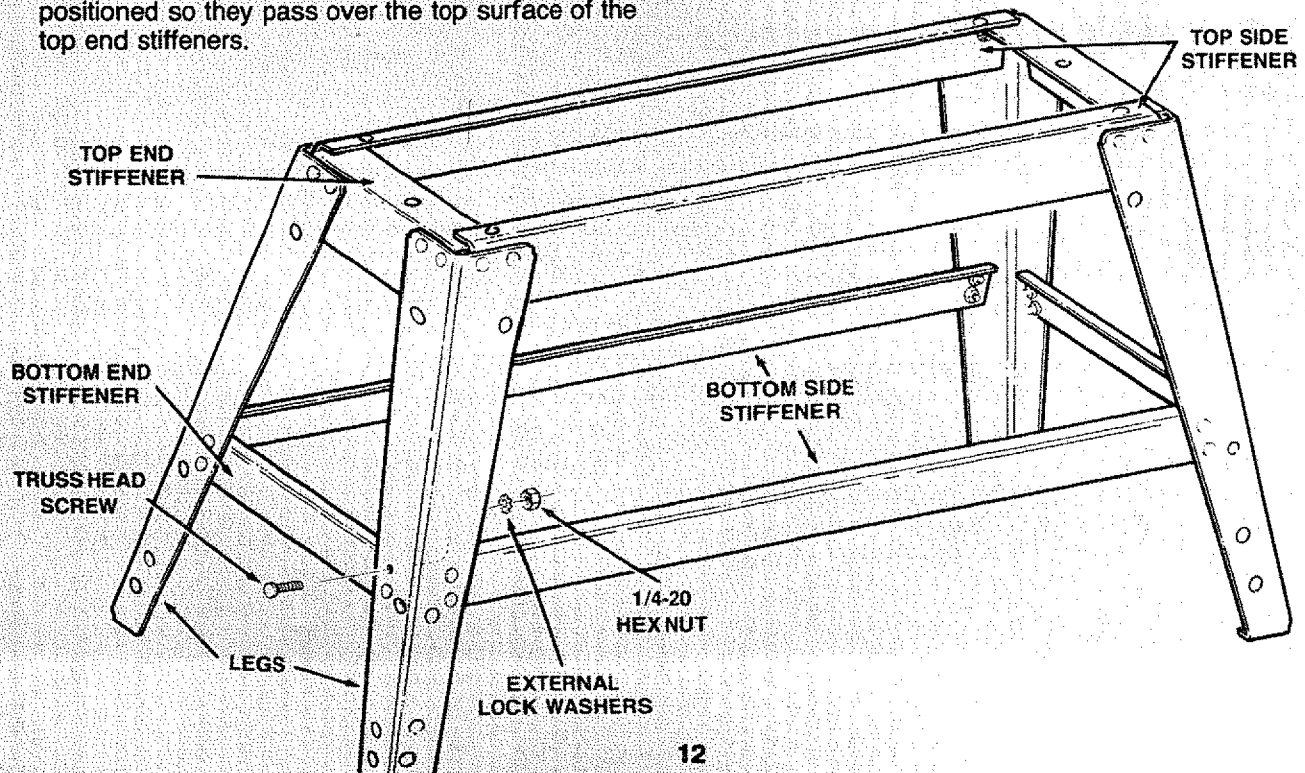

- From the loose parts bag find four (4) leveling feet and eight (8) 3/8"-16 hex nuts. Install leveling feet as shown. Later when the Jointer/Planer is completely assembled and put in its permanent location in your workshop, you'll need to level the leg set. To level leg set, loosen nut on inside of leg and turn nut on the outside to raise or lower feet. Adjust all four leveling feet, if necessary, and then tighten nuts on the inside of leg.

NOTE: These levelers are not intended for height adjustment.

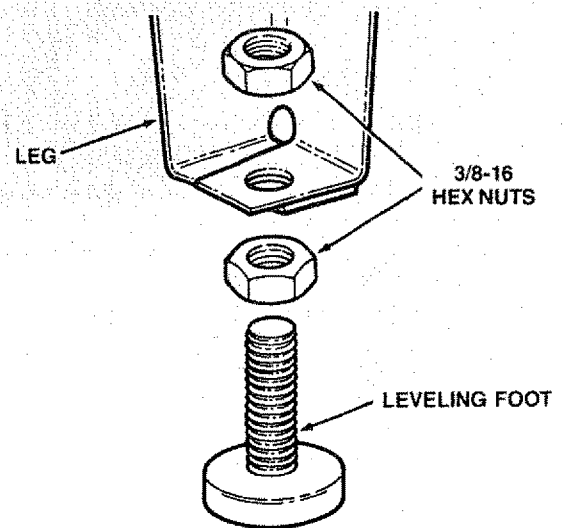

INSTALLING DRIVE BELT AND ADJUSTING BELT TENSION

WARNING: DO NOT LET ANY PART OF YOUR BODY TOUCH THE CUTTER HEAD. IT CONTAINS VERY SHARP CUTTER KNIVES WHICH COULD CUT YOU BADLY.

- From the loose parts find the drive belt and the pulley. From the packing material used in the jointer box, find two (2) large pieces of styrofoam.

SPECIAL NOTE: When turning the Jointer/Planer upside down do not put the weight of the Jointer/Planer on the guard or the guard may be broken. Do not roll the Jointer/Planer over because this may also break the guard.

- Put the two pieces of styrofoam on the floor and put the Jointer/Planer upside down on the cardboard as illustrated.

WARNING: DO NOT TURN THE MOTOR ON UNTIL THE JOINTER/PLANNER IS COMPLETELY ASSEMBLED AND TURNED RIGHT SIDE UP WITH THE LEVELING FEET SETTING AGAINST THE FLOOR. IF THIS WARNING IS NOT FOLLOWED THE MOTOR AND START SWITCH MAY BE BURNED OUT. YOU COULD ALSO BE BADLY CUT BY THE VERY SHARP KNIVES ON THE CUTTER HEAD.

- Locate the two motor mounting bolts on the underside of the jointer. Using a 1/2" socket, 6" extension, and a socket wrench loosen these two motor mounting bolts.
- Slide the motor pulley onto the motor shaft as illustrated with the set screw side of pulley toward the jointer.

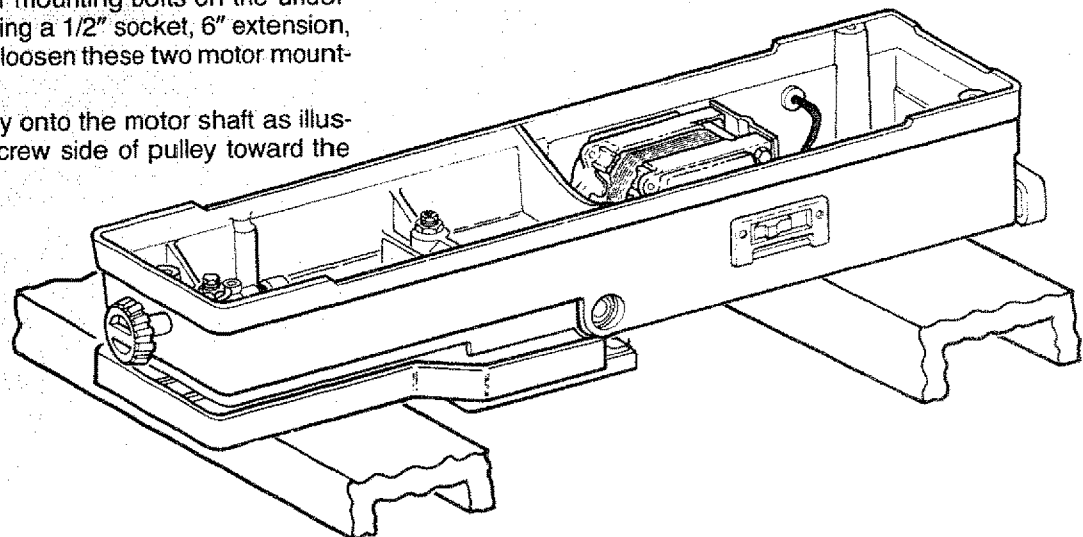
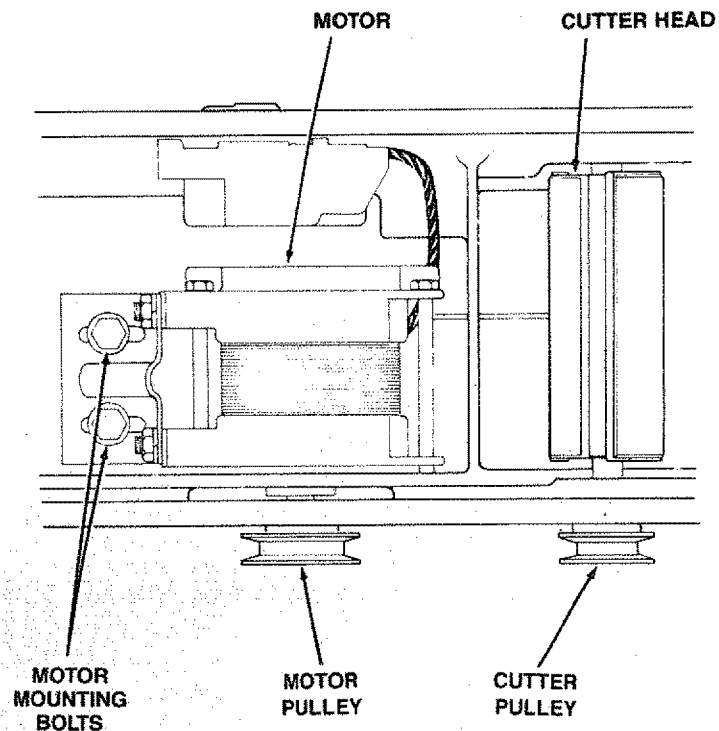

5. Move the motor toward the cutter head and put the drive belt around the two pulleys.
6. Look at the drive belt to see that it runs straight between the two pulleys. If the belt does not run parallel with the wall of the jointer/planer, it is not straight and should be adjusted.

To make this adjustment, slide the pulley in or out on the motor shaft, until the belt is parallel with the wall of the jointer/planer. Using the 5/32 Hex-L wrench tighten the motor pulley set screw. Be sure the set screw is over the flattened section on the motor shaft before tightening set screw.

WARNING: DO NOT MAKE THIS ADJUSTMENT BY MOVING THE CUTTERHEAD PULLEY. FAILURE TO OBSERVE THIS WARNING MAY CAUSE THE CUTTERHEAD TO MOVE OUT OF ITS PROPER POSITION ALLOWING THE CUTTER KNIVES TO HIT THE METAL BASE CASTING.

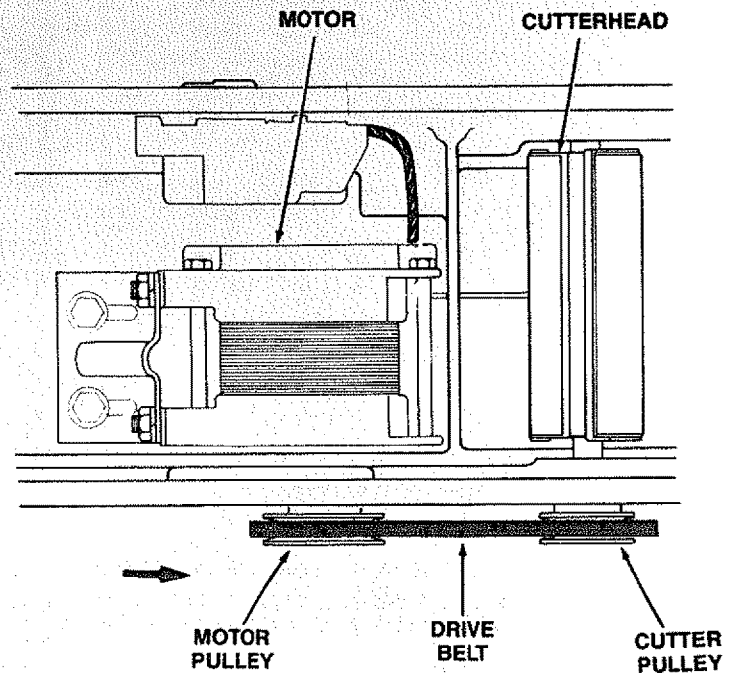

7. Apply tension to the belt by moving the motor away from the cutter head. The end of the motor closest to the motor pulley must stay as near parallel to the wall of the jointer/planer as possible.
8. Hold the motor in the position that provides proper belt tension and retighten the two motor mounting bolts. The belt has been tensioned properly when you can deflect the belt 3/8 of an inch by pushing down on the belt at a point midway between the two pulleys.
9. Recheck belt alignment and tension after tightening motor mounting bolts. Readjust if necessary.

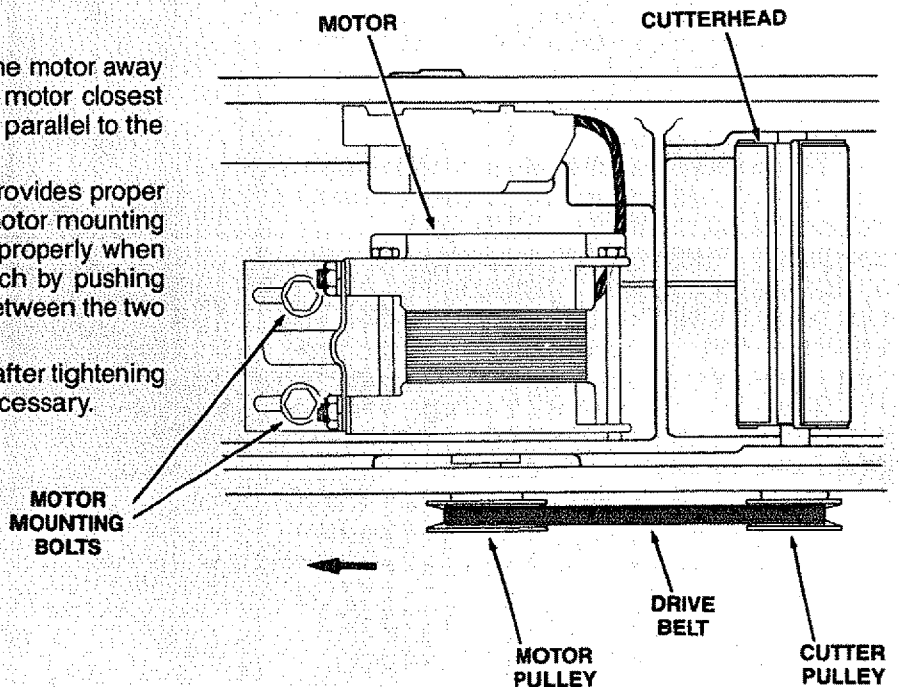

MOUNTING THE JOINTER/PLANER

1. From the loose parts find three (3) 3/8-16 x 3/4" hex head bolts, and three (3) 3/8" internal lock washers.
2. Place the leg set on top of the jointer/planer and align the three (3) mounting holes on the bottom side of the jointer/planer with the holes in the leg set (see illustration).
3. Place a lock washer on each bolt. Using your fingers, screw the bolts through the leg set holes and into the mounting holes in the jointer/planer. Tighten the bolts securely using a 9/16 inch wrench.
4. Using a 7/16" socket wrench tighten all nuts and bolts that hold the leg set together.
5. Get another person to help you turn the jointer right side up so the leveling feet are against the floor.

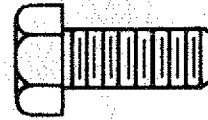

HEX HEAD
BOLT



INTERNAL
LOCKWASHER

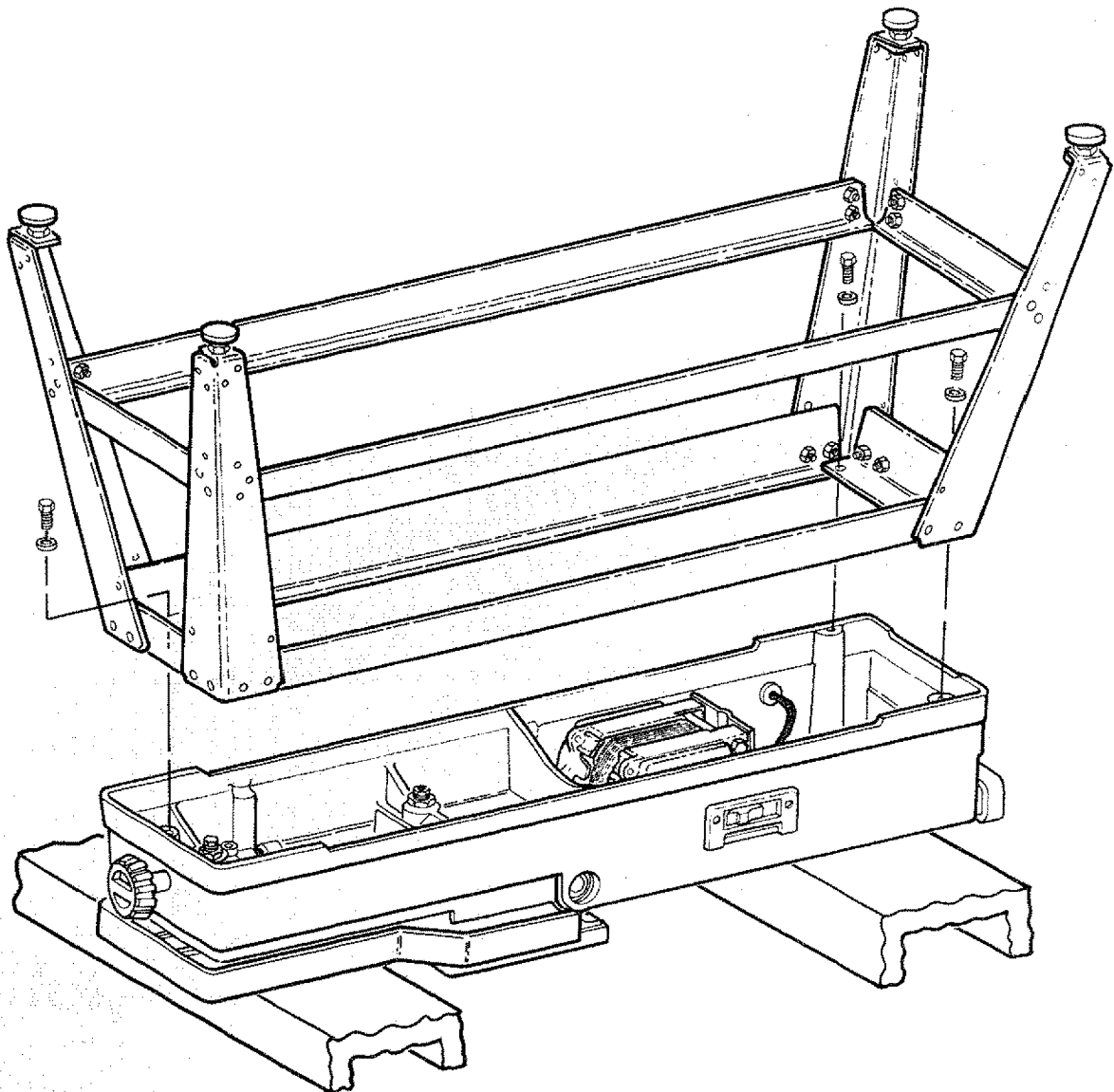

CHECKING CUTTER KNIVES AND SCREWS

WARNING: THE CUTTER KNIVES ARE EXTREMELY SHARP. DO NOT LET YOUR HAND OR FINGERS TOUCH THE CUTTER KNIVES.

TOOLS NEEDED

5/32" and 1/8" Hex-L Wrenches
Short straight edge (or head of combination square)

1. Lower the infeed table with the Depth of Cut Hand-wheel by turning it counterclockwise.

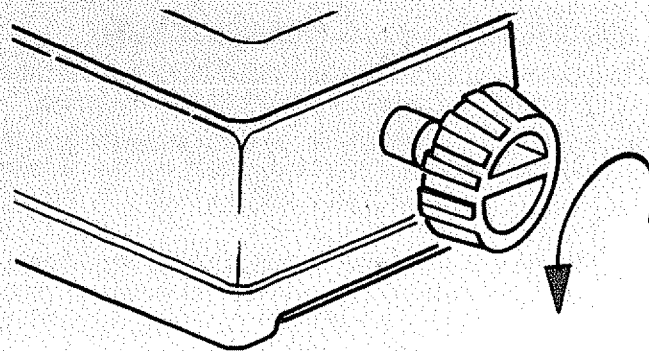

2. The following steps need to be done three times—once with the straight edge near the end of the cutterhead—once at the middle of the cutterhead—and once at the opposite end of the cutterhead.
 - a. Put a piece of notebook paper on the outfeed table.
 - b. Put the straight edge, on its edge, on top of the paper so the straight edge extends across the cutterhead opening between the tables.
 - c. Turn the cutterhead by rotating the 2 inch diameter pulley attached to the cutterhead shaft.
 - d. As you turn the cutterhead make sure all three knives on the cutterhead just touch the straight edge at all three positions. If not, follow the procedure given under "REPLACING CUTTER KNIVES."

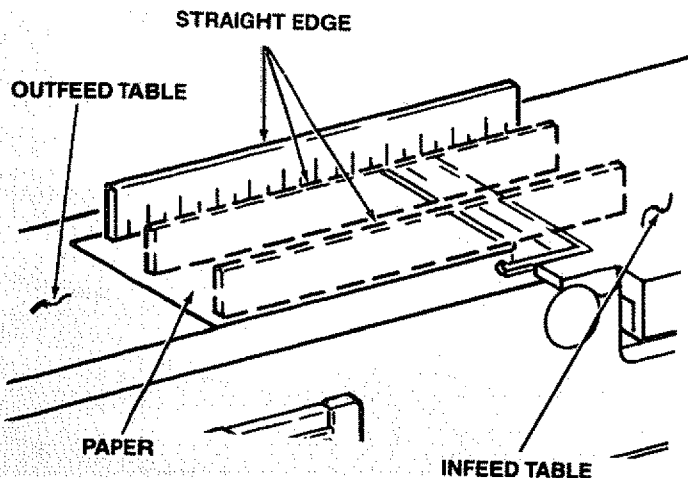

- e. If cutter knife adjustment is not required, check each locking screw on each wedge (5/32" Hex-L wrench) and tighten if necessary. Hold the 2 inch pulley in a stationary position to prevent the cutterhead from turning during this tightening procedure.

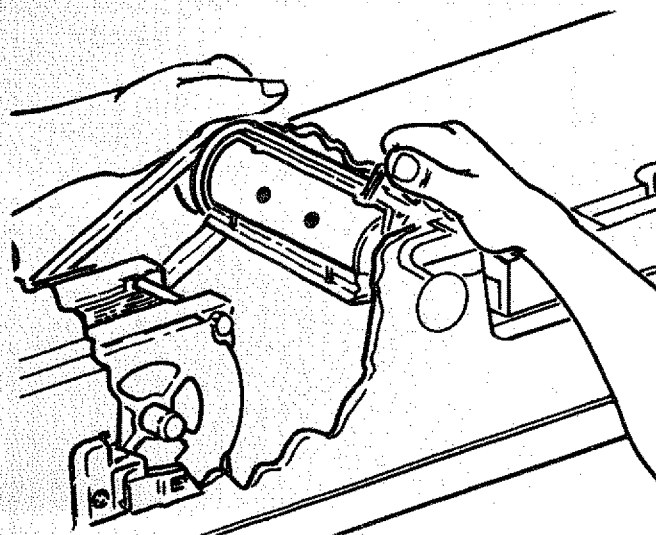
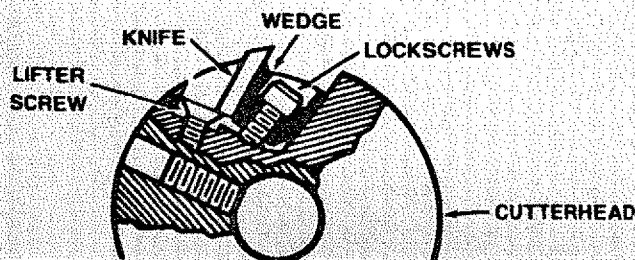

INSTALLING FENCE

1. Rotate the cutter guard counterclockwise and place the fence on the jointer table as shown.
2. Locate the following parts from the loose parts bag and install as shown:

One (1) 3/8-16 x 2-1/2 carriage bolt, one (1) retainer, one (1) .380 x 1-5/32 x 3/32 flat washer, one (1) spacer, and one (1) knob.

3. Attach the fence to the jointer as illustrated below.
4. Rotate the cutter guard counterclockwise away from the fence and then release it. The spring tension on the guard must cause it to swing back against the fence. If the guard does not swing back against the fence, recheck your assembly procedure. Do not use the jointer/planer if the guard will not automatically swing back against the fence and cover the cutter head.

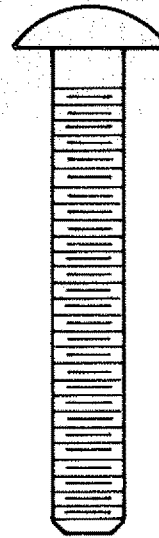

CARRIAGE BOLT

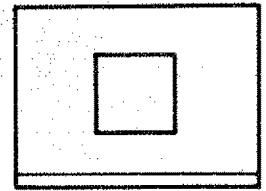

RETAINER



SPACER

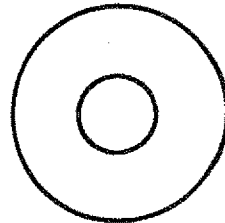

FLAT WASHER

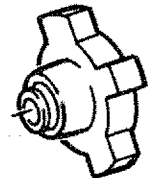

KNOB

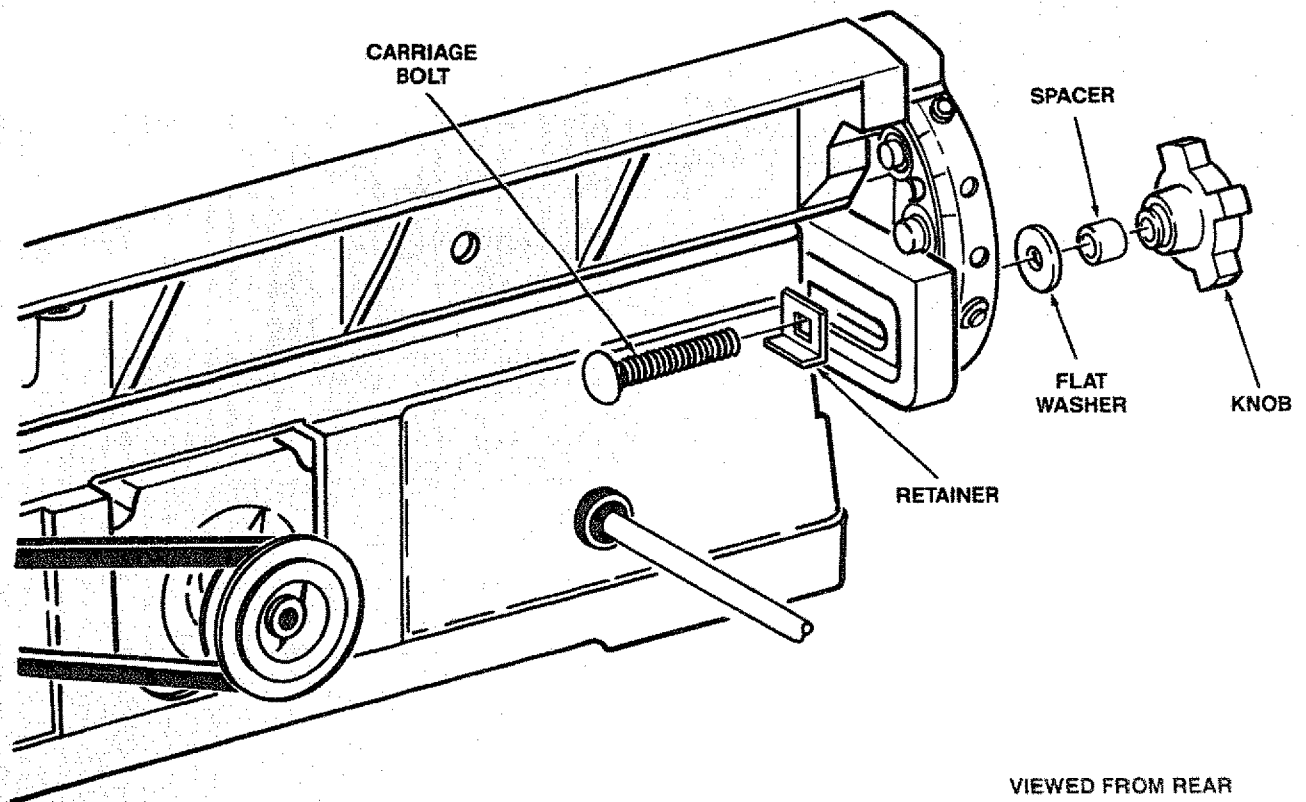

INSTALLING BELT GUARD AND SLIDING GUARD

From the loose parts find the following:

One (1) sliding guard, one (1) sliding guard knob, one (1) sliding guard rod, two (2) sliding guard plastic washers (one side of washer is concave), one (1) hex nut 1/2"-13.

One (1) Split lockwasher 1/2", two (2) 10-32 x 1/4" Pan. Hd. Screws, two (2) #10 External Lock Washers, two (2) 10-32 x 2-3/4" Pan Hd. Screws, One (1) Belt Guard.

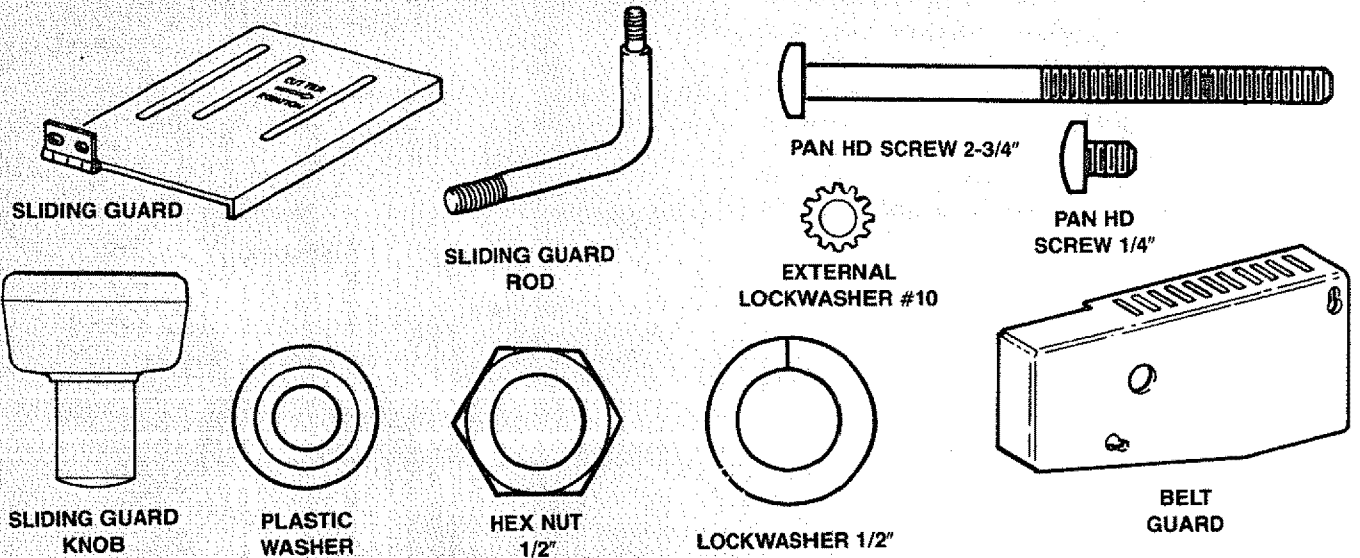

1. Screw a 1/2" nut all the way onto the long end of the rod . . . place a 1/2" lockwasher next to the nut (as illustrated).
2. Screw the sliding guard rod into the jointer as far as it will go with the short end of the rod pointing straight up. (See Illustration)
3. Tighten the 1/2" nut to hold the rod securely in this position.

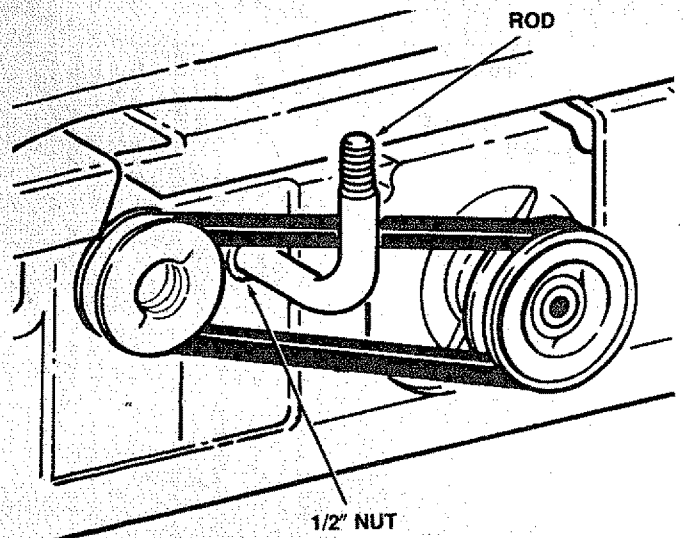
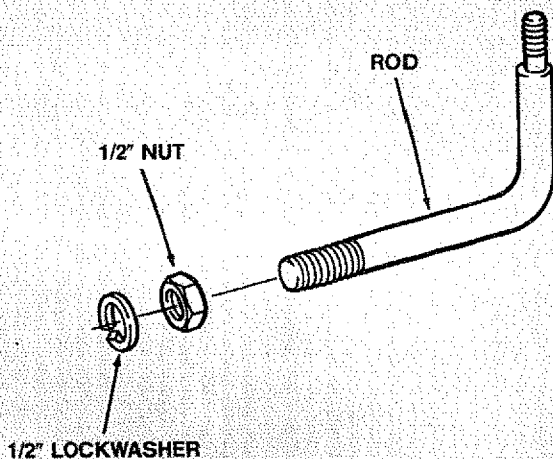

- Slide the belt guard over the rod and attach it to the base of the jointer with two 2-3/4" long Pan. Hd. screws. Make sure the belt does not scrape the guard.

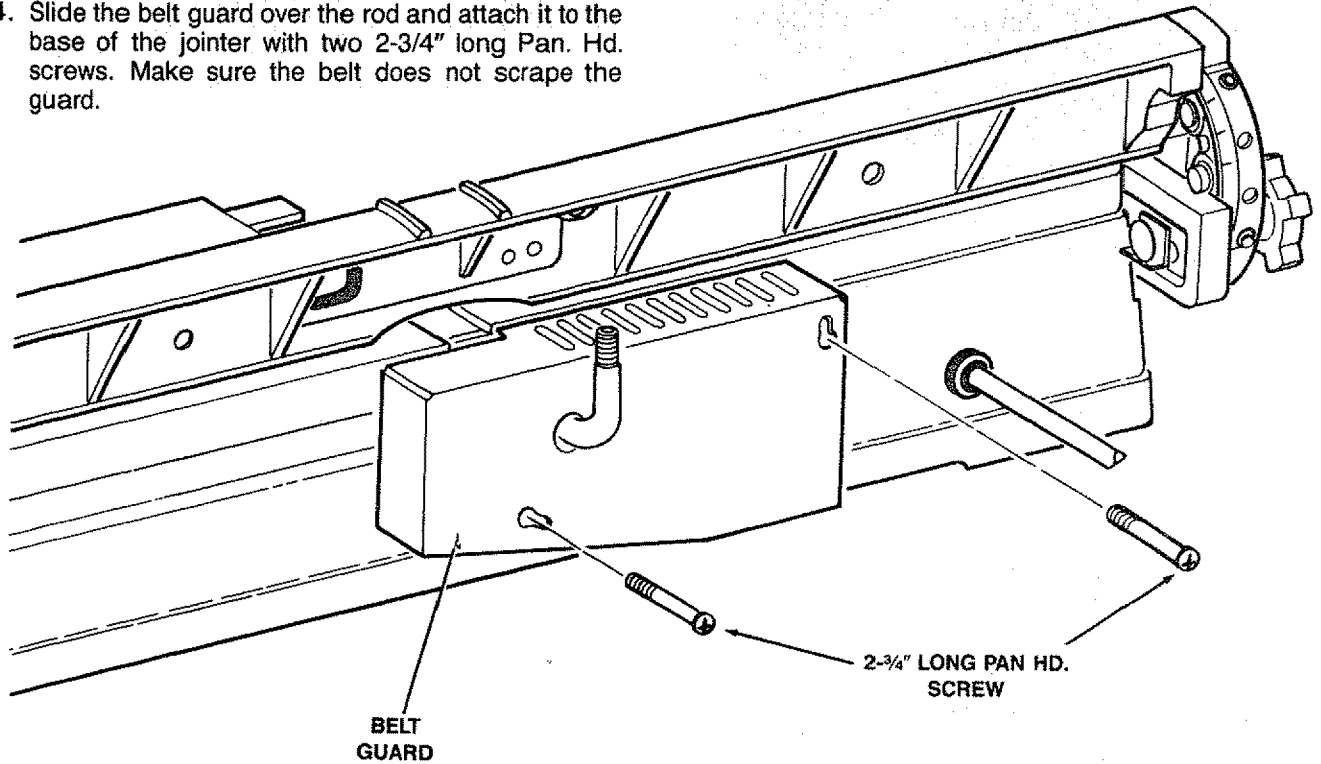

- Attach sliding guard to fence with two pan head screws and lockwashers.
- Place one Sliding Guard/Washer, concave side DOWN on support rod.
- Drop sliding guard onto rod . . . place other washer, concave side UP on rod . . . screw on Sliding Guard Knob.

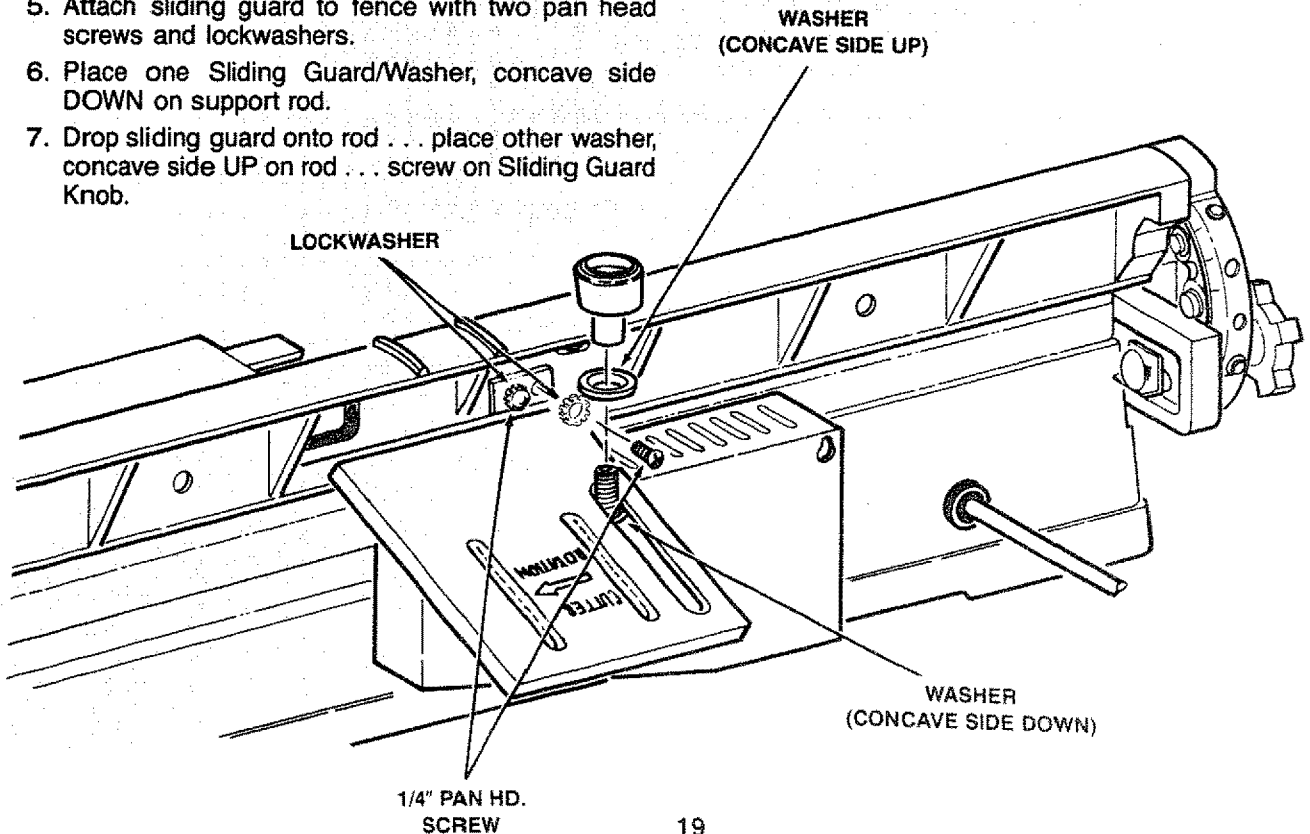

getting to know your jointer-planer

WARNING: FOR YOUR OWN SAFETY ALWAYS LOCK THE SWITCH "OFF" WHEN JOINTER-PLANER IS NOT IN USE. REMOVE KEY AND KEEP IT IN A SAFE PLACE . . . ALSO IN THE EVENT OF A POWER FAILURE, TURN SWITCH OFF. LOCK IT AND REMOVE THE KEY. THIS WILL PREVENT THE JOINTER/PLANER FROM STARTING UP AGAIN WHEN THE POWER COMES BACK ON.

WARNING: FOR YOUR OWN SAFETY TURN SWITCH "OFF" AND REMOVE PLUG FROM POWER SOURCE OUTLET BEFORE MAKING ANY ADJUSTMENTS.

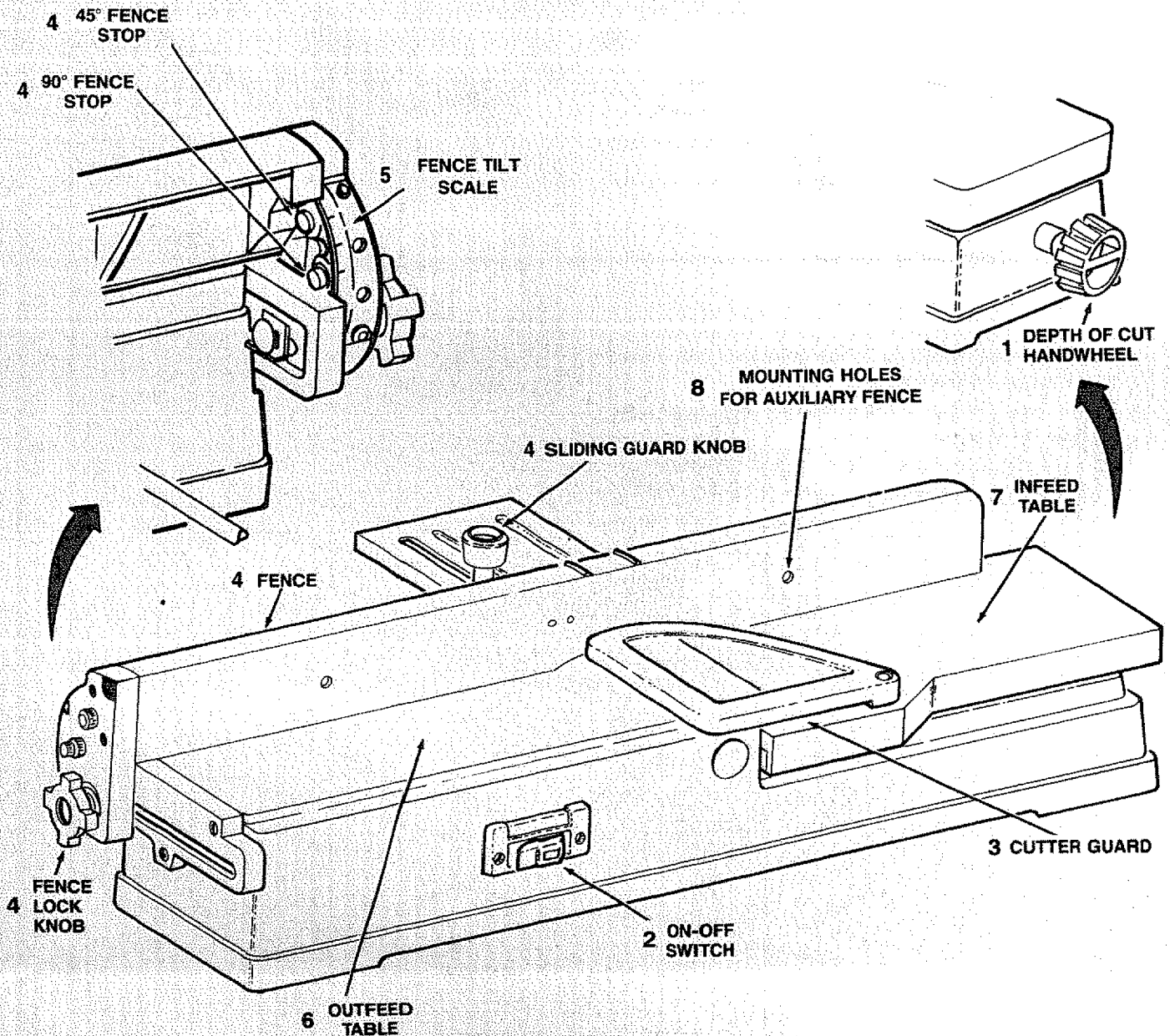

1. DEPTH OF CUT HANDWHEEL.

Turning the handwheel counterclockwise will lower the infeed table. This will cause more wood to be removed from the workpiece during the cutting operation.

Turning the handwheel clockwise will raise the infeed table causing less wood to be removed from the workpiece.

The maximum amount of wood that can be removed during one cut is 1/8".

When adjusting the handwheel, always lower the table lower than it needs to be and then raise the table to the desired depth of cut. Failure to do this may cause the infeed table to be out of parallel with the outfeed table.

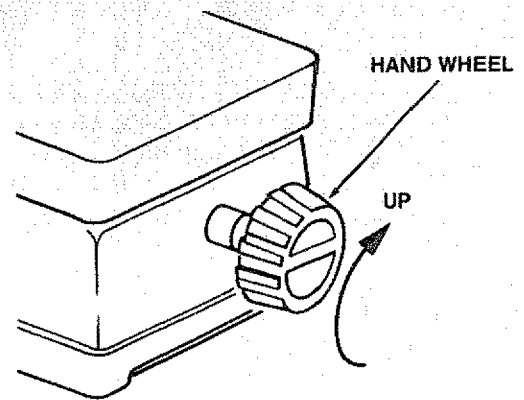

2. ON-OFF SWITCH.

The on-off switch is shaped to make turning it "ON" accidentally less likely.

In an emergency, it can be turned "OFF" by striking it with the palm of the hand.

The "yellow button" is a key. When it is inserted in the switch lever, the power may be turned ON and OFF. When it is removed, the power cannot be turned ON.

THIS FEATURE IS INTENDED TO HELP PREVENT UNAUTHORIZED AND POSSIBLE HAZARDOUS USE BY CHILDREN AND OTHERS.

a. Insert Key into switch.

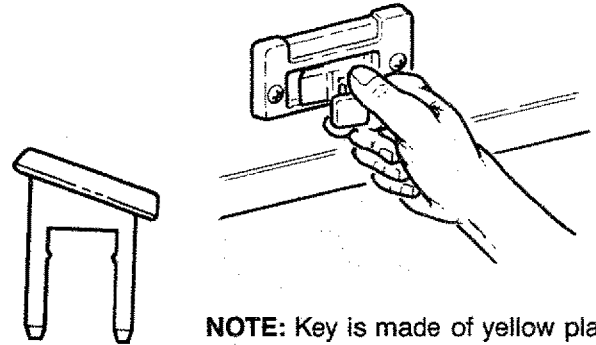

NOTE: Key is made of yellow plastic.

b. To turn the tool on, insert your finger under the switch lever and pull the end of the switch out.

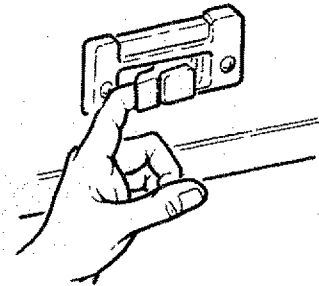

c. To turn the tool OFF . . . PUSH the lever in.
Never leave the machine unattended until it has come to a complete stop.

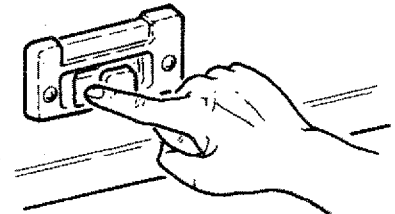

d. To lock the switch in the OFF position . . . hold the switch IN with one hand . . . REMOVE the key with the other hand.

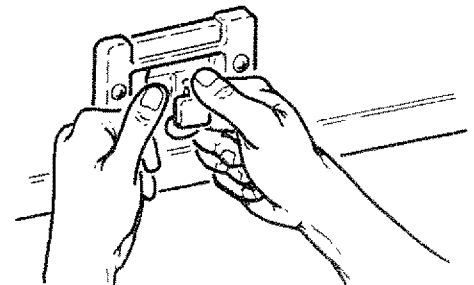

WARNING: FOR YOUR OWN SAFETY, ALWAYS LOCK THE SWITCH "OFF" WHEN MACHINE IS NOT IN USE . . . REMOVE KEY AND KEEP IT IN A SAFE PLACE . . . ALSO . . . IF THE TOOL STOPS UNEXPECTEDLY, TURN SWITCH OFF . . . AND REMOVE THE KEY. THIS WILL PREVENT THE MACHINE FROM STARTING UP AGAIN WHEN THE POWER COMES BACK ON.

3. **WARNING: CUTTER GUARD** helps provide protection over the cutterhead. It must always be in place and functioning properly.

With the power off and the switch key removed, check the guard to make sure it is functioning properly.

- Position the fence to the rear of the table for maximum width of cut.
- Pass a 1/4 inch thick piece of wood over the cutterhead between the guard and the fence.

The guard must return automatically to a "rest position" against the fence when free of the wood.

If guard does not return automatically, have it checked by a Sears Service Center.

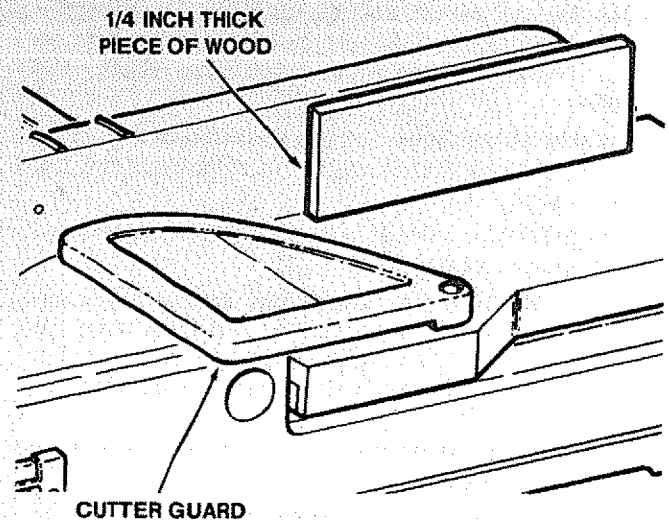

4. **FENCE LOCK AND STOPS.** The fence can be moved across the Jointer to take full advantage of the "sharpness" of the blades.

When blades are new or freshly sharpened the fence should be positioned to the extreme rear of outfeed and infeed tables but not beyond the end of the blades.

Most of the cutting (usually jointing) will be done with the fence in this position. As the blades become dull, the fence can be moved toward the front of the tables where the blades are sharper.

To move the fence, loosen the Fence Lock Knob and the Sliding Guard Knob and slide the fence to the desired position.

SPECIAL NOTE: Make sure SLIDE BRACKET is even with surface of OUTFEED TABLE. If it is above or below the surface, loosen screws and adjust it.

- Always tighten fence lock knob first to align fence, then tighten sliding guard knob.
- Before tightening fence lock knob, hold fence down on outfeed table so it does not rock.
- 90° Fence Stop positions fence square to tables. To tilt fence, loosen the fence lock knob and sliding guard knob and pull the stop out. Tilt to desired angle and tighten both knobs.
- To set fence at 90° to tables, loosen the two knobs, tilt fence so the stop springs back into place. Tilt fence back so the stop rests on the table. Hold fence down on outfeed table and tighten both knobs.
- 45° Fence Stop positions the fence at 45° to the tables.
- To tilt fence to 45°, loosen the two knobs, pull 90° stop out, tilt fence so the 45° stop rests on the table.
- Hold fence down on outfeed table and tighten the two knobs.

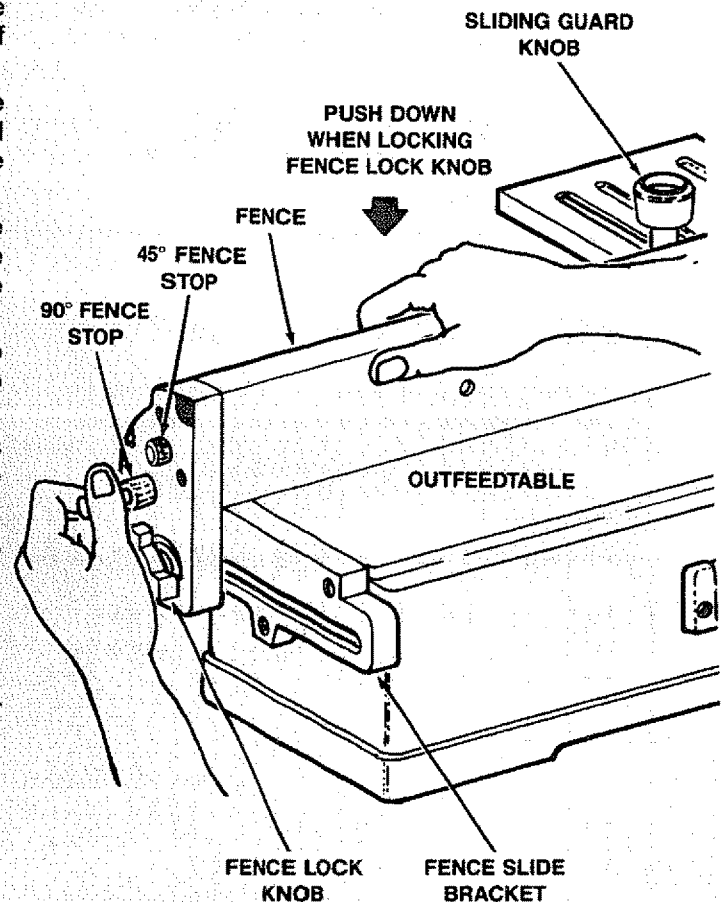

5. FENCE TILT SCALE.

Indicates the angle of the fence to the tables. When the 90° fence stop is correctly adjusted, the fence will be 90° to the table and the scale will read 90°.

To check for squareness, place an accurate square on infeed table and check fence while locked at 90° position. **MAKE SURE 90° STOP IS AGAINST SLIDE BRACKET.**

If fence is not square to table:

- Slightly loosen fence lock knob and guard lock knob.
- Loosen 90° stop screw with small screwdriver and turn knurled sleeve which will cause fence to tilt. Turn sleeve in either direction until fence is square with infeed table.

NOTE: If you cannot square fence by turning knurled sleeve, loosen three screws "A" and adjust fence square to table.

- Tighten 90° stop lock screw and both fence lock knobs.
- If 90° reading on tilt scale does not line up with top surface of the slide bracket, loosen screws holding scale and move it . . . tighten screws.

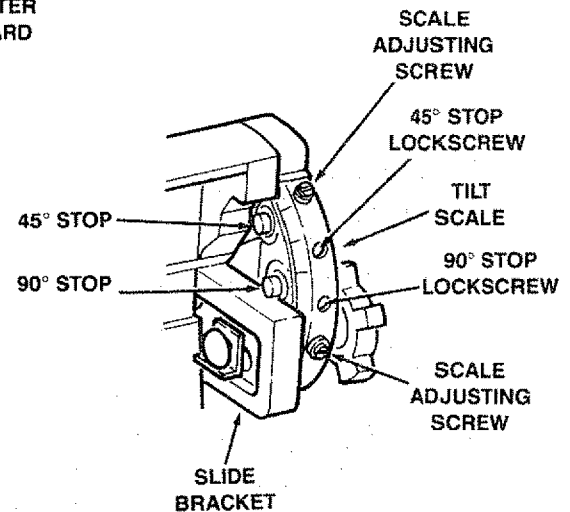
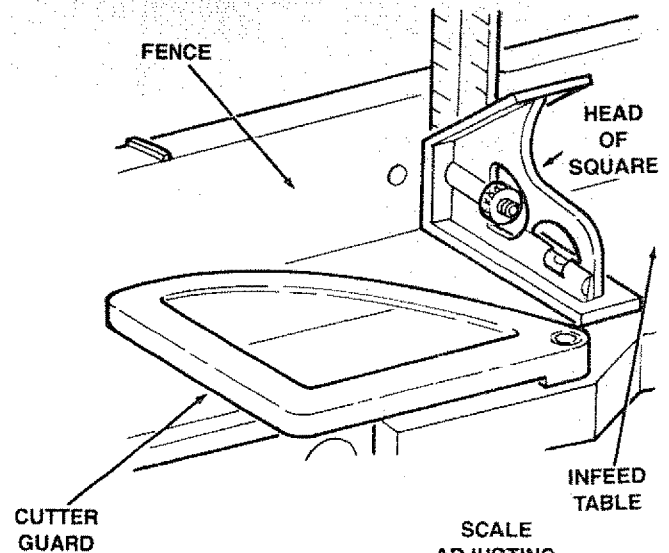
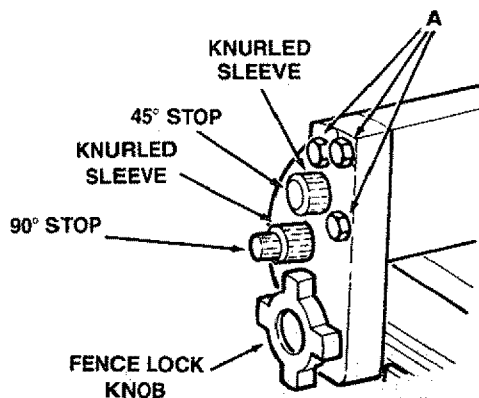

- Adjust 45° stop in the same manner.

NOTE: Tilt scale will not require adjustment if it was adjusted for 90° position.

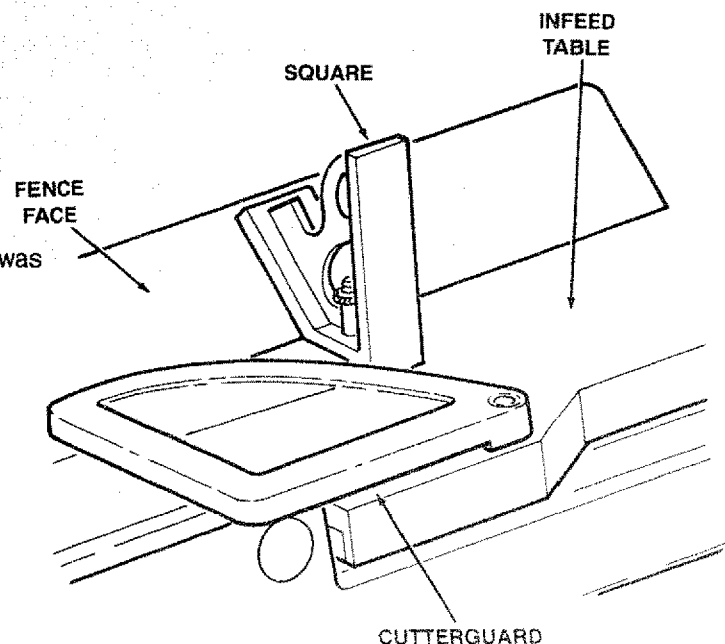

6. OUTFEED TABLE.

Supports the workpiece after it has passed the cutter head.

7. INFEEED TABLE.

MUST ALWAYS BE PARALLEL TO THE OUTFEED TABLE.

If the cut edge or surface of the workpiece is **CROWNED**, it is an indication that the **OUTWARD END** of the **INFEEED** table is **HIGH** and must be adjusted.

If the cut edge or surface of the workpiece is **CONCAVE**, it is an indication that the **OUTWARD END** of the **INFEEED** table is **LOW** and must be adjusted.

To check the infeed table to determine the "out of parallel" condition, do the following:

- Turn the cutterguard counterclockwise until an indentation in the metal surface under the cutterguard is exposed. Put the yellow on-off switch key into the indentation. Release the cutter guard so it is held open by the key.
- Put a straightedge (large square or long level) on the outfeed table. First along one side then along the other.

NOTE: The straight edge must not touch the cutter knives.

- Raise the infeed table until it touches the straightedge.
- Look between the table and straightedge to see if there is a high or low condition at the end of the infeed table.

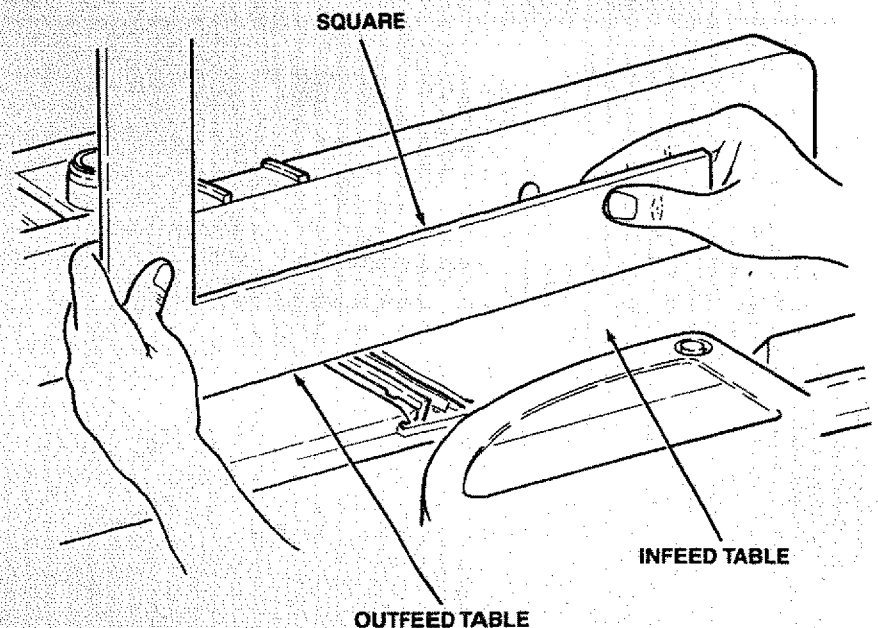
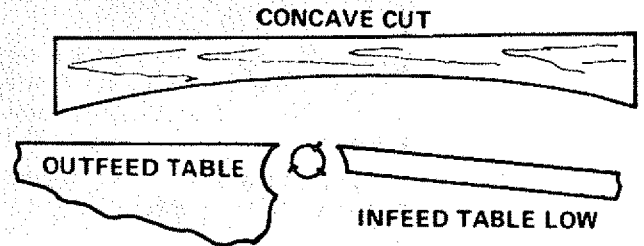
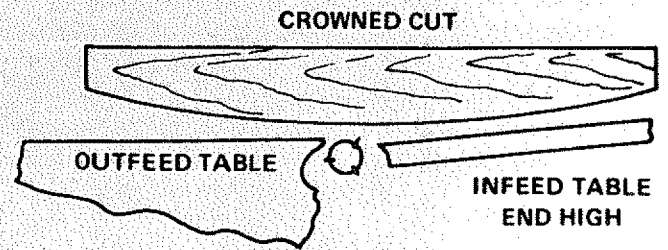

Adjusting the infeed table so it is parallel to the out-feed table can be a time consuming process. To complete the adjustment in as little time as possible follow these steps carefully.

- a. Put the yellow on-off switch key in the rectangular shaped indentation exposed as you turn the cutter guard counterclockwise. This will hold cutter guard open.

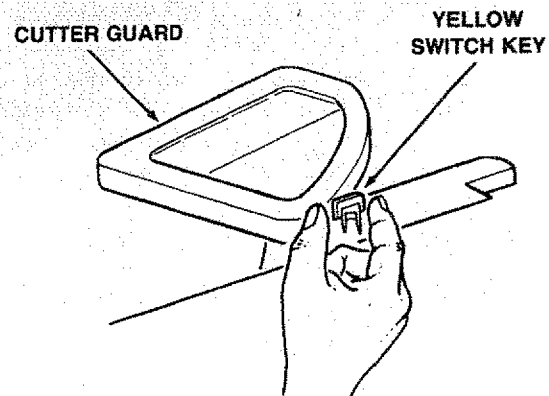

VIEW FROM BACKSIDE JOINTER/PLANER

- b. Wrap a peice of cardboard around cutterhead to protect your fingers and the blades . . . secure cardboard with a piece of tape.

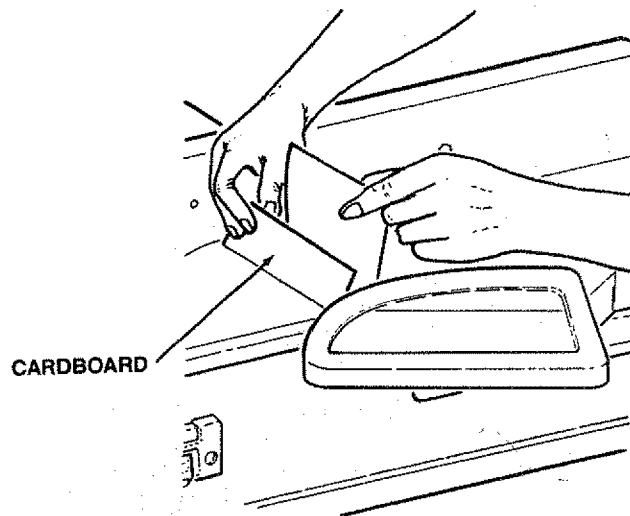

- c. Using a 1/2 inch open end wrench, loosen the lockbolts 1/2 turn under the section of the table that is low. Loosen no more of the lockbolts than is necessary.

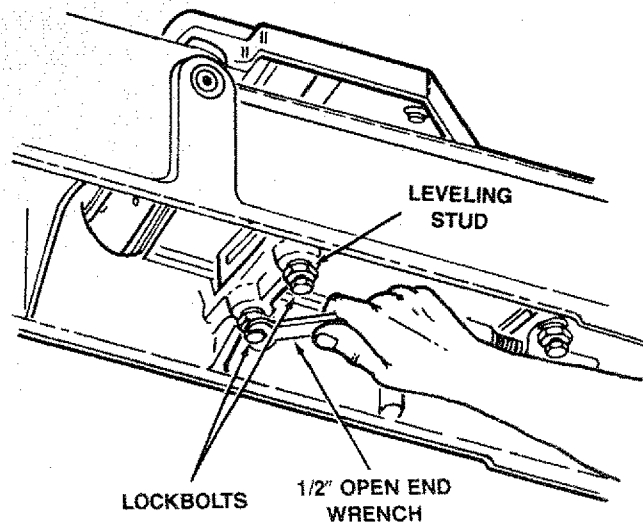

- d. Where you have loosened the lockbolts, use a 3/4" open end wrench to turn the leveling studs until the infeed table is parallel with the straight edge at both the front and rear of the table.

NOTE: Turning the leveling studs clockwise will raise the table. Turning them counterclockwise will lower the table.

- e. Hold each leveling stud in position using a 3/4" open end wrench and begin to tighten the lockbolts—tighten each bolt a little bit at a time. As the lockbolts are tightened the position of the table may be changed slightly. So check frequently with the straight edge to be sure the table is staying parallel with the outfeed table. It may be necessary to readjust a leveling stud slightly several times, at the same time you are tightening its lockbolt.
- f. Recheck with the straightedge to make sure the infeed table is level. If it is not, go through the above steps again.

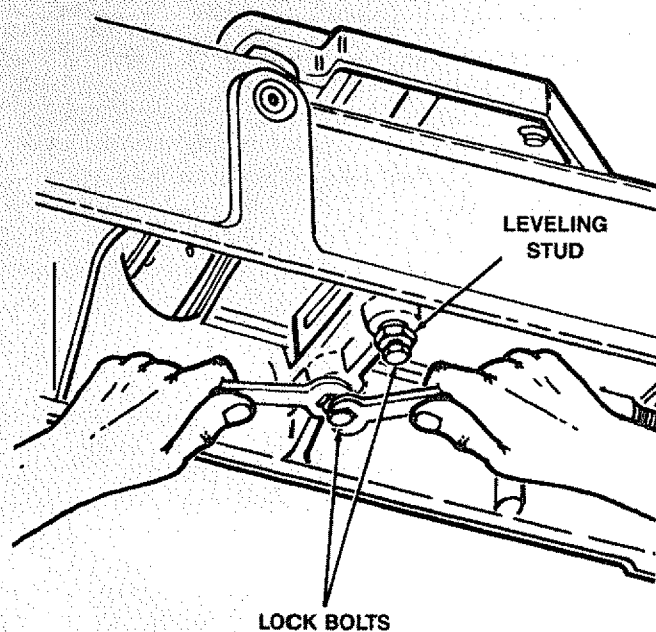

8. MOUNTING HOLES FOR AUXILIARY FENCE.

These holes are provided so you may attach an auxiliary fence to the front of the cast iron fence. An auxiliary fence should be used anytime you joint boards wider than 4-1/2 inches. The auxiliary fence should be made from a smooth straight board and cut to a width that will cause the auxiliary fence to be no more than 1 inch narrower than the board being jointed.

Attach the auxiliary fence as illustrated.

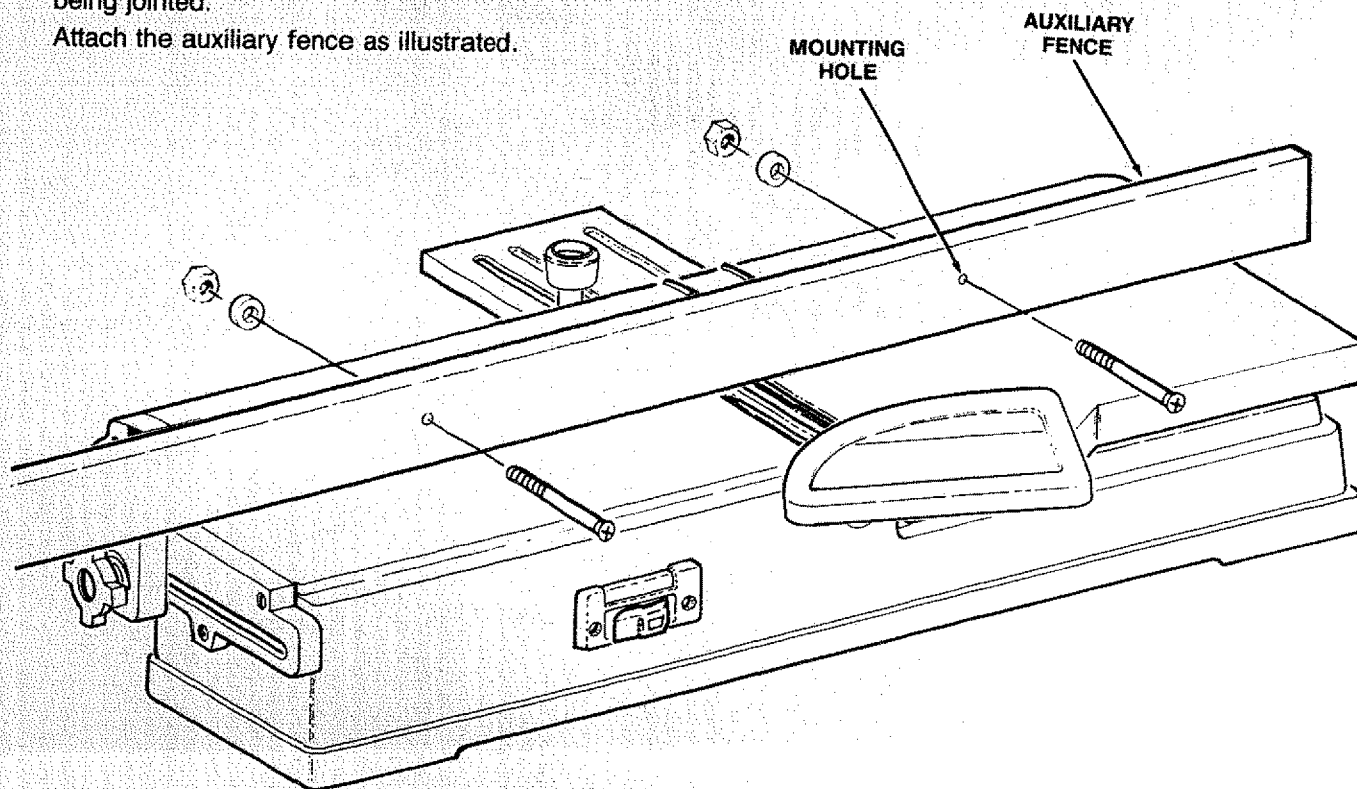

basic jointer-planer operation

BEFORE EACH USE

Plan Your Work to protect your eyes, hands, face, ears.

1. Carefully plan your hand placement. Make sure you have proper hold-down/push-blocks, jigs, fixtures, stops, etc. ready to use.
2. Do layout, assembly or set up work on the table only while the jointer-planer is off and the switch key removed.
3. Wear safety goggles that comply with ANSI Z87.1
4. For dusty operations, wear a dust mask along with safety goggles.
5. Plan your work to match your workpiece:
 - a. Surface plane warped wood on the concave side for best results.
 - b. Don't joint or plane plywood, particle board, other composition materials or wood that has glue, paint or varnish on it. Materials like these will quickly dull the blades.
 - c. Make sure there are no nails or foreign objects in the part of the workpiece to be cut.
 - d. Never cut FREEHAND. Guide your workpiece solidly against the fence and table top.

Small or thin workpieces can kickback when they tip over on the table or into the cutterhead. To avoid cutterhead contact or workpiece kickback:

1. NEVER joint, plane or bevel workpieces **shorter than 12 inches**.
2. When **Jointing or Beveling**:
 - a. Never joint or bevel workpieces less than 3/4 inch wide or 1/4 inch thick.
 - b. Always use the hold-down/push-blocks when jointing or beveling wood narrower than 3 inches.
3. When **Planing**:
 - a. Never plane wood thinner than 1/2 inch.
 - b. Always use hold-down/push-blocks when planing wood thinner than 3 inches.
4. To avoid risk of hearing damage, wear ear plugs or muffs during extended periods of operation.
5. To avoid being suddenly pulled into the blade:
 - a. Do not wear gloves.

- b. Remove all jewelry and loose clothing.
 - c. Tie back long hair.
 - d. Roll long sleeves above the elbow.
6. To avoid burns or other fire damage, never use the jointer-planer near flammable liquids, vapors or gases.
 7. To avoid injury from slips and jams:
 - a. Use this jointer-planer to cut only wood.
 - b. Plan your hand placement so your fingers will not be anywhere a sudden slip could cause them to slide or fall into the cutter head. When using only one hold-down/push-block to feed the wood, do not put your other hand on the Jointer-Planer, workpiece or hold-down/push-blocks.
 - c. Make sure all clamps and locks are tight and there is no excessive play in any parts.
 8. Adjust the depth of cut to between 1/32 and 1/16 of an inch for best results in most operations. A deep cut makes feeding the wood harder and can cause the wood to kickback. To be sure you will make a depth of cut you planned, always lower the infeed table slightly farther than you wanted. Then, raise the table to the desired depth.
 9. Before using the jointer-planer, clear the table of all objects not needed to feed the workpiece.
 10. To avoid injury from unsafe accessories, use only recommended accessories.

Whenever Jointer-Planer is running

1. Make sure bystanders are clear of the tool and workpiece.
2. Before actually cutting with the jointer-planer, let it run for awhile. If your jointer-planer makes an unfamiliar noise or if it vibrates excessively, stop immediately. Do not restart until finding and correcting the problem.
3. To avoid injury from slips, stalls or kickback, feed the workpiece into the jointer-planer only fast enough to let the tool cut without bogging down or binding.
4. Before freeing jammed material, turn switch off, remove switch key, unplug the jointer and wait for all moving parts to stop.

Feeding the workpiece

Hold the board firmly **DOWN** on both tables and **AGAINST** the fence . . . keep fingers close together.

Feed the board at a continuous even rate of speed until the cut is made along the entire length of the board. Any hesitation or stopping could cause a "step" to be cut on the edge of the board which would cause the board to ride up on the outfeed table resulting in a "crooked" edge on the board.

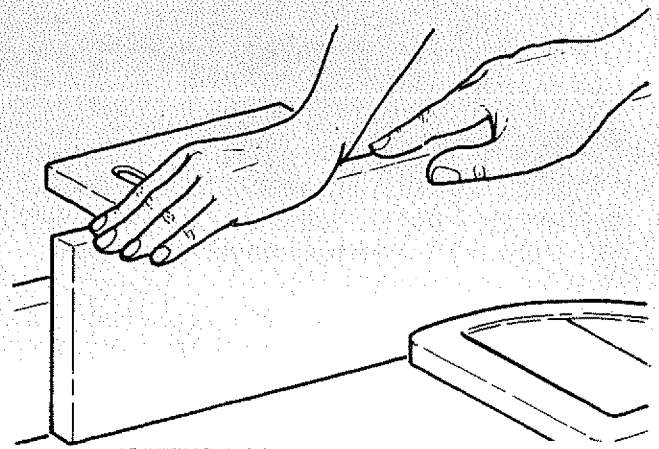

JOINTING WOOD THAT IS WIDER THAN 3 INCHES

As the **TRAILING** hand passes over the cutterhead, remove the **LEADING** hand . . . **CONTINUE** feeding while placing the **LEADING** hand behind the **TRAILING** hand. Continue feeding in this manner "hand over hand," until the entire length of the board is cut. **Pressure should be applied over the cutterhead and outfeed table.**

DO NOT FEED TOO FAST. A slow steady rate of feed produces a smooth accurate cut. Feeding too fast causes a "rippled" cut . . . makes it difficult to guide the workpiece accurately and could be hazardous.

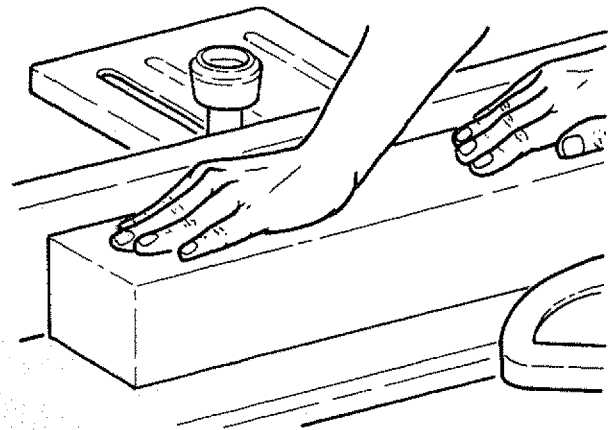

JOINTING WOOD THAT IS THICKER THAN 3 INCHES

Always feed **WITH THE GRAIN** whenever possible. If the nature of the workpiece is such that it must be fed **AGAINST THE GRAIN**, take very light cuts and feed slowly.

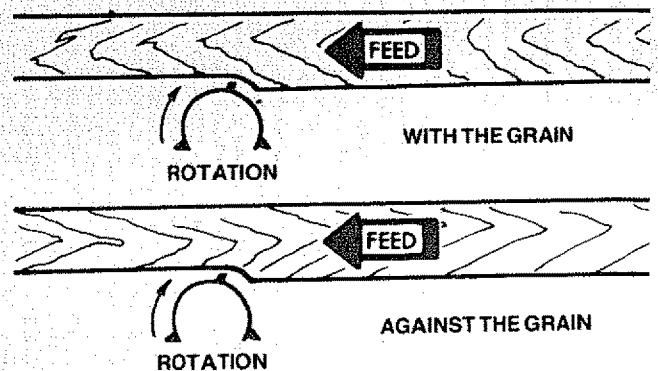

Support Long Workpieces

To avoid injury from slips or kickbacks, use extra supports (tables, saw horses, etc.) at both infeed and outfeed ends if your workpiece is hard to hold down to the table.

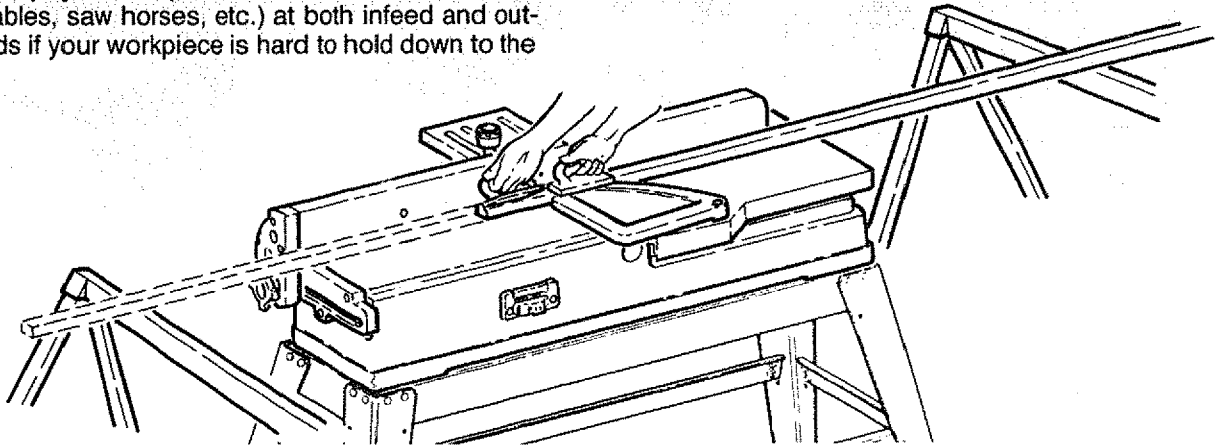

A SAWHORSE OR HOMEMADE SUPPORT WILL DO

Using the hold-down/push-blocks

ALWAYS use the hold-down/push-blocks when JOINTING wood that is NARROWER than 3 inches or planing wood that is thinner than 3 inches (as illustrated).

Grasp the hold-down/push-blocks firmly with the fingers close together and wrapped around the handle. Position the hold-down/push-blocks flat on top of workpiece, and push the workpiece down against the table to provide a quality cut and minimize the chance of a kickback.

Hold-down pressure must also be sufficient to prevent hold-down/push-block sliding or slipping on the top face of workpiece when advancing workpiece over cutter head.

Use a hand-over-hand motion of the hold-down/push-blocks, being careful to maintain control over the workpiece at all times.

This means that once the workpiece has been fed past the cutter head onto the outfeed table, one hold-down/push-block must always maintain contact of workpiece with outfeed table.

WARNING: IF THE HOLD-DOWN/PUSH-BLOCKS TEND TO SLIP WHILE FEEDING, CLEAN RUBBER SURFACE IMMEDIATELY WITH SANDPAPER.

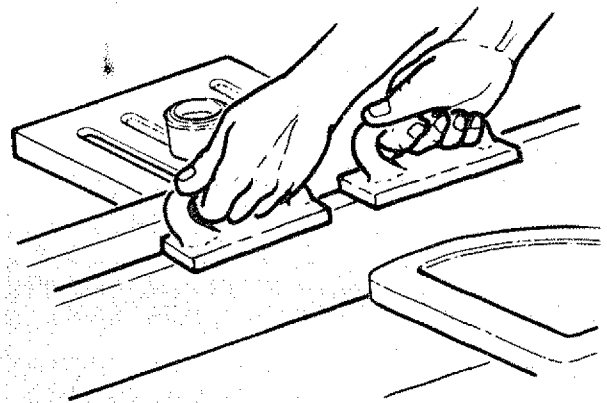

JOINTING WOOD NARROWER THAN 3 INCHES

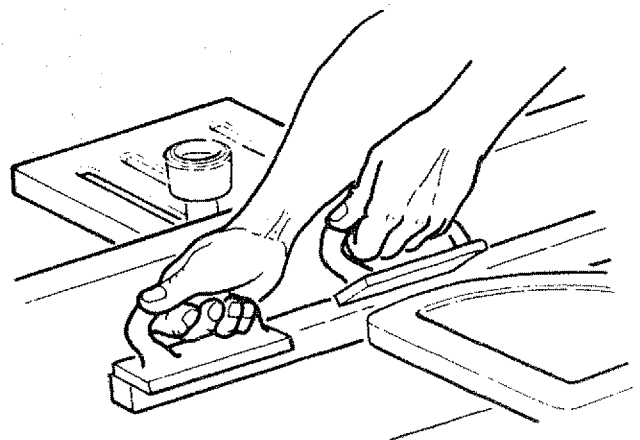

PLANING WOOD THINNER THAN 3 INCHES

When planing wood between 1/2 inch and 3/4 of an inch thick and **NARROWER** than the hold-down/push-block, tilt the hold-down/push-block so that it clears the tip of the cutterguard while feeding.

Never plane wood that is thinner than 1/2 inch. It is apt to split or shatter and thus has a greater tendency to kickback.

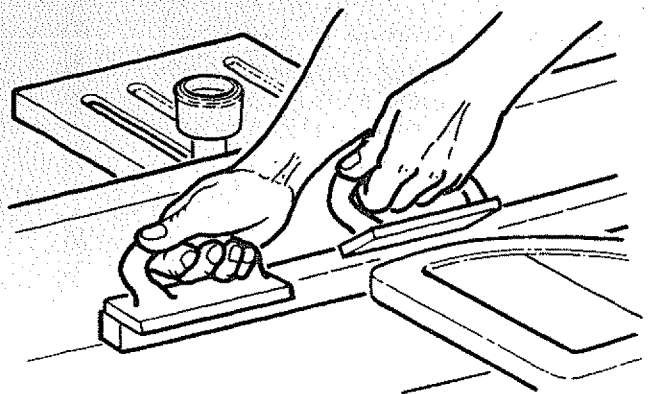

PLANING WOOD 3/4 INCH THICK AND NARROWER THAN THE PUSH BLOCK

Beveling

Adjust the fence to the desired angle . . . lock fence in position using fence lock knob and sliding guard knob.

For pieces of wood 3 inches or wider hold the board firmly down on both tables and firmly against the fence (as illustrated) with your hands on the side and top of the workpiece . . . keep fingers close together.

NOTE: Removing only the corner on the edge of a board is known as **CHAMFERING** while beveling is removing the corner or the edge of the board down to the board's surface.

Normally a chamfer is made with one cut . . . therefore, a cut deeper than 1/16 of an inch may be made.

For pieces of wood less than 3 inches wide use hold-down/push-blocks (as illustrated) on the side of the workpiece so you can hold the workpiece in toward the fence at all times as well as down against the table top.

WARNING: DO NOT CONTACT THE CUTTING KNIVES OR THE GUARD WITH THE PUSH BLOCKS.

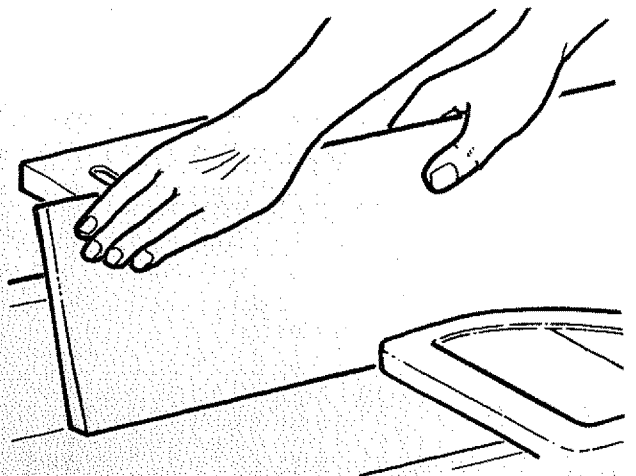

BEVELING WOOD WIDER THAN 3 INCHES

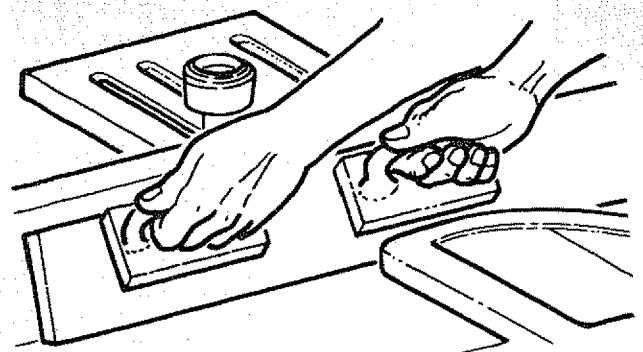
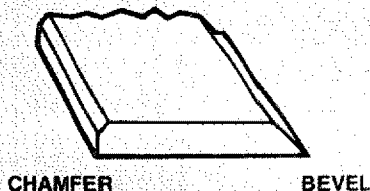

BEVELING WOOD NARROWER THAN 3 INCHES

NOTE: Rabbeting on a Jointer is considered to be a dangerous operation because it requires removal of the cutter guard and increases the potential of kickback because of excessive depth of cut.

NEVER ATTEMPT TO PERFORM A RABBETING OPERATION ON THIS JOINTER. DO NOT OPERATE JOINTER/PLANER WITH CUTTERHEAD GUARD REMOVED.

Rabbet cuts should be made on the Radial Saw or Table Saw by making two cuts with the sawblade or by using the Dado Head or Molding Head. Rabbet cuts can also be made using the Shaper or Portable Router.

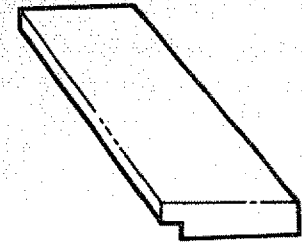

RABBET CUT

maintenance

Do not allow pitch to accumulate on the tables, the fence, the cutter guard, the cutter head or the knives. Clean them with Craftsman Gum and Pitch Remover.

Apply a thin coat of paste type wax to the tables and the fence so that the wood slides easily while feeding. This also deters rusting.

Do not allow chips to accumulate on the underside of the jointer-planer.

If power cord is worn or cut, or damaged in any way, have it replaced immediately.

If disassembly of the motor is necessary, it should be returned to your nearest Sears retail or mail order store in order to prevent voiding the guarantee.

NOTE: The speed of this motor cannot be regulated or changed.

Motors used on wood-working tools are particularly susceptible to the accumulation of sawdust and wood chips and should be blown out or "vacuumed" frequently to prevent interference with normal motor ventilation.

REPLACING CUTTER KNIVES

WARNING: FOR YOUR OWN SAFETY, TURN SWITCH "OFF" AND REMOVE PLUG FROM POWER SOURCE OUTLET BEFORE ADJUSTING, MAINTAINING, OR LUBRICATING YOUR JOINTER-PLANER.

1. Remove the belt guard as follows:
 - a. Use a screwdriver to loosen both screws, shown in illustration.
 - b. Remove sliding guard knob from sliding guard rod. Turn the knob counterclockwise to unscrew it from the rod. Raise sliding guard to a vertical position.
 - c. Slide the belt guard out away from the jointer and up off the rod.

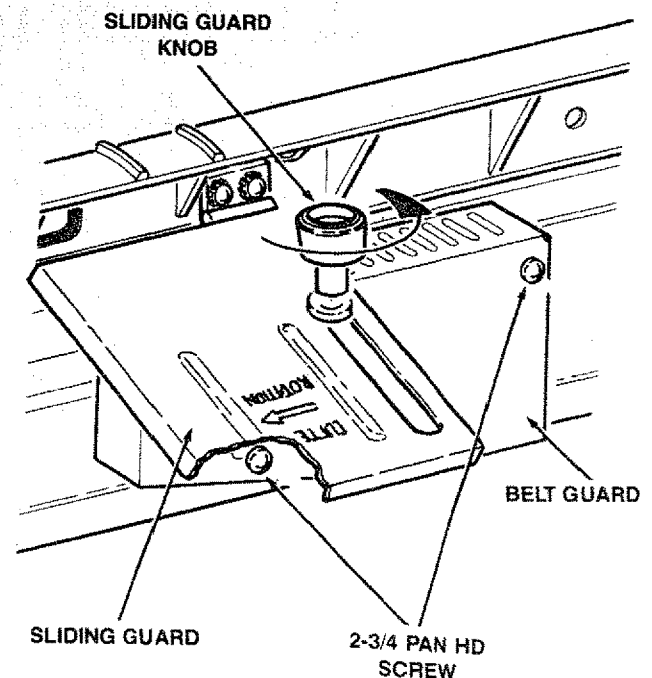

2. Position the fence to the rear of the jointer . . . approximately 1/4 inch beyond the cutter knives . . . lock the fence in this position.
3. Lower infeed table all the way down.
4. Turn the cutterguard counterclockwise until an indentation in the metal surface under the cutterguard is exposed. Place the yellow on-off switch key in this indentation. Rest the cutterguard against the yellow key so the guard is held open by the yellow key.

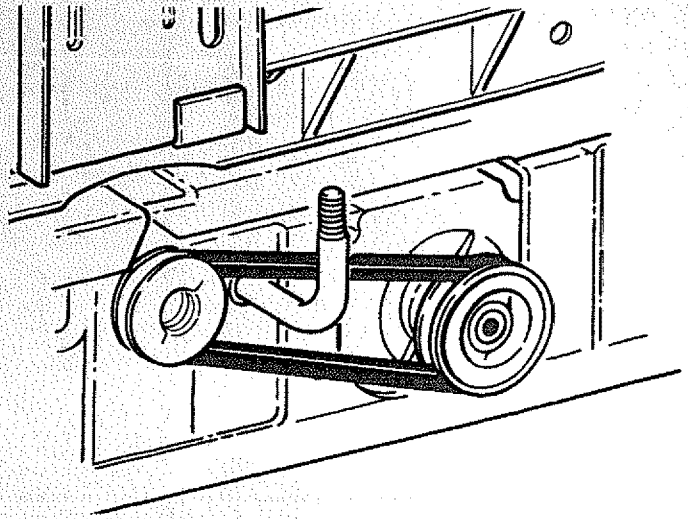

5. Hold cutterhead pulley firmly with one hand and loosen lock screws in each wedge 3 or 4 turns using a 5/32 inch Hex "L" wrench.

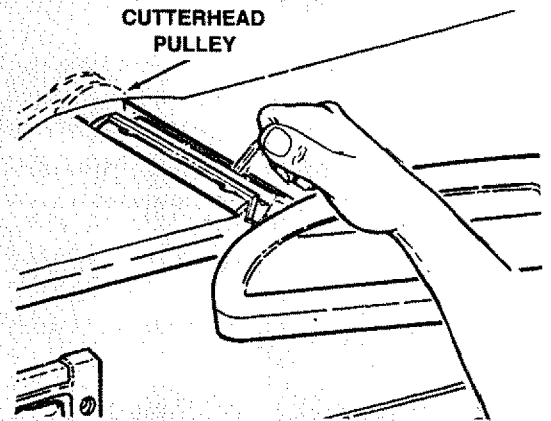
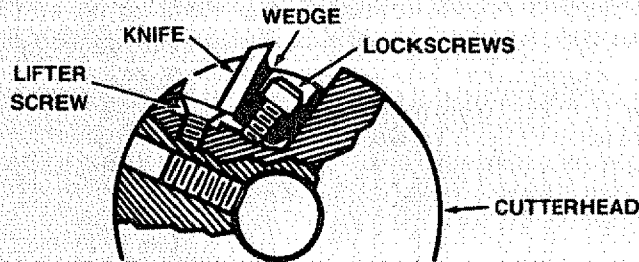

WARNING: DO NOT USE SCREWDRIVERS AS PRY BARS. THEIR HARDENED TIPS CAN SHATTER UNEXPECTEDLY. PARTS MAY LOOSEN SUDDENLY. TO AVOID EYE INJURY, WEAR SAFETY GOGGLES.

6. While holding the cutterhead pulley firmly with one hand, gently pry up each wedge using a small pry bar. Remove wedges and knives.

Another method that can be used to remove cutter knives is as follows:

- a. Locate the two lifter screws under the knife.
- b. Hold the cutterhead pulley firmly with one hand to prevent the cutter head from turning.
- c. Using a 1/8" Hex-L wrench, turn one of the lifter screws 1/4 of a turn counterclockwise.
- d. Now turn the other lifter screw 1/4 of a turn counterclockwise.
- e. Continue turning first one lifter screw and then the other 1/4 of a turn at a time until the knife has been removed.

NOTE: If you are unable to remove the knives using this process you should lubricate the wedges and knives with penetrating oil. Let the penetrating oil soak in between the knives and wedges for a short time. Now, perform steps A through E again and the knives should come out.

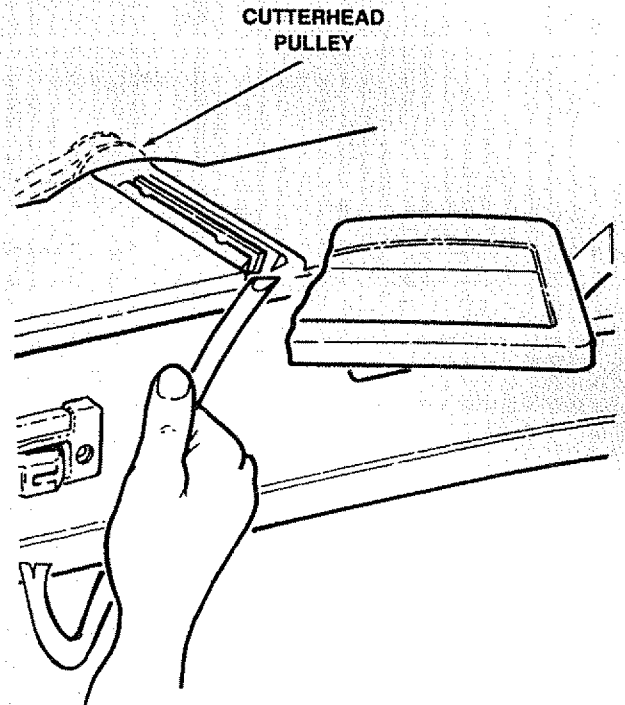

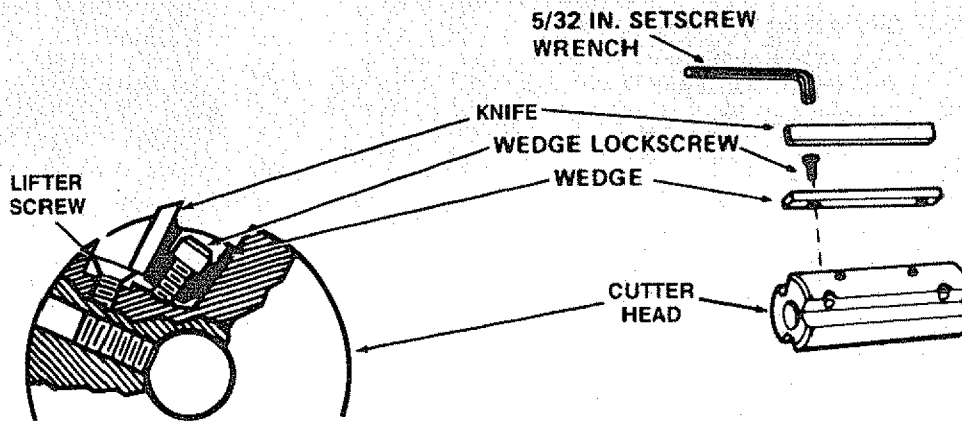

7. Using a 1/8" Hex "L" wrench, remove the six lifter screws. (Two under each blade.)
8. Clean cutterhead, wedges and screws thoroughly with Craftsman Gum and Pitch Remover. Also remove the oil from new blades.
9. Replace the six lifter screws and screw them in all the way, but do not tighten.
10. Insert a knife in one of the slots . . . so it projects 1/16 of an inch beyond each end of the cutterhead. Note that the face with the cutting edge is against the wedge as shown.
11. Insert a wedge next to knife so the flat side of the wedge is against the knife. Push wedge in manually—do not install two locking setscrews at this time.

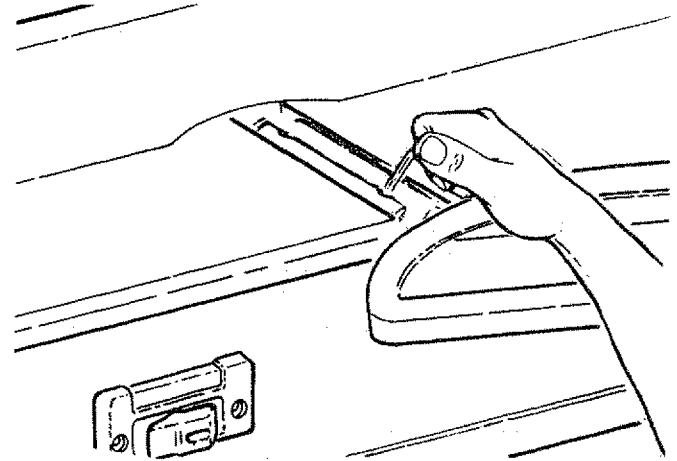

12. Adjust cutter knives as follows:
 - a. Put a piece of notebook paper on top of the outfeed table.
 - b. Put the head of a square on top of the paper. The end of the square must extend past the end of the outfeed table and above one end of the cutterhead.
 - c. Turn the lifter screws counterclockwise to raise the knife until it just touches the square.
 - d. To check your adjustment, gently turn the cutterhead back and forth by moving the cutterhead pulley. The knife should just touch the square without raising the square off the paper. This same adjustment must be made at the other end of the cutterhead.
 - e. If the adjustment is done correctly, the knives will now be slightly above the outfeed table by approximately .003 of an inch (the thickness of an average piece of paper).

NOTE: This adjustment can be made more accurately by using a knife setting gauge (Cat. #9-2647) available at Sears.

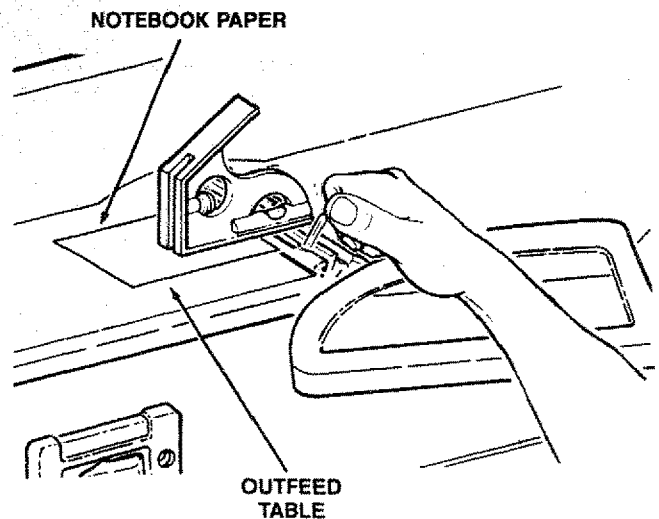

13. Now install both locking setscrews and tighten (with the 5/32" Hex-L wrench) alternately a little at a time. Tighten both screws securely. Recheck the blade to make sure it did not change position.
14. Install the other two knives in the same way.
15. Reinstall the belt guard, sliding guard, and sliding guard knob.

CAUTION: THE CUTTER KNIVES ARE VERY SHARP. TO PREVENT A SLIP OF THE HAND WHICH COULD CAUSE CUTTING OF YOUR HAND, ALWAYS HOLD ONTO THE CUTTERHEAD PULLEY TO PREVENT ACCIDENTAL ROTATION OF THE CUTTERHEAD.

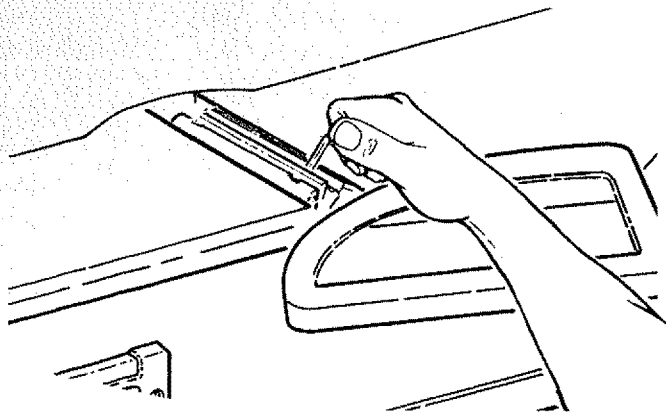

SHARPENING CUTTER KNIVES

The knives can be honed individually with an ordinary oilstone.

Make sure your oilstone is not worn in the center. It must be flat.

Be sure to remove the burr on the flat side.

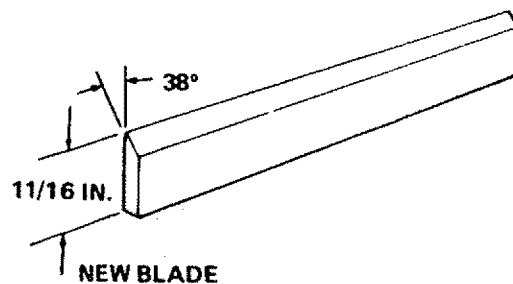

If the knives are nicked, they must be replaced or reground. They can be reground several times until they become 9/16 in. wide. **Never install reground knives less than 9/16 in. wide or unbalanced knives.**

Have your knives reground by someone who is competent. Look in the "Yellow Pages" of your telephone directory . . . see "Sharpening Services."

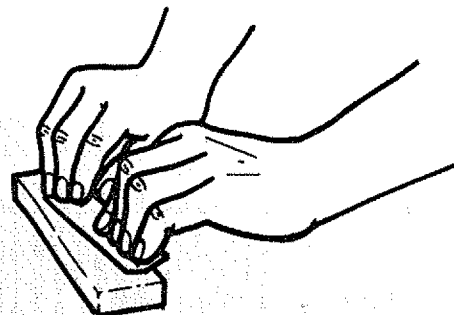

INSTALLING (REPLACING) CUTTER GUARD SPRING

1. Using a 1/2 inch socket wrench, unscrew the self-threading nut.
2. Remove guard and throw away old spring. Install new spring as shown.
3. Position guard as shown, with PIVOT PIN above hole in infeed table.
4. Align SLOTS in the guard and infeed table with TANGS on spring, and press down.
5. While holding the guard down with the spring in the correct position install the self-threading nut. The thread of the nut must face the table. Leave a 3/32 inch gap between the bottom of the guard and top of the infeed table when the nut is tightened against the bottom of the infeed table.

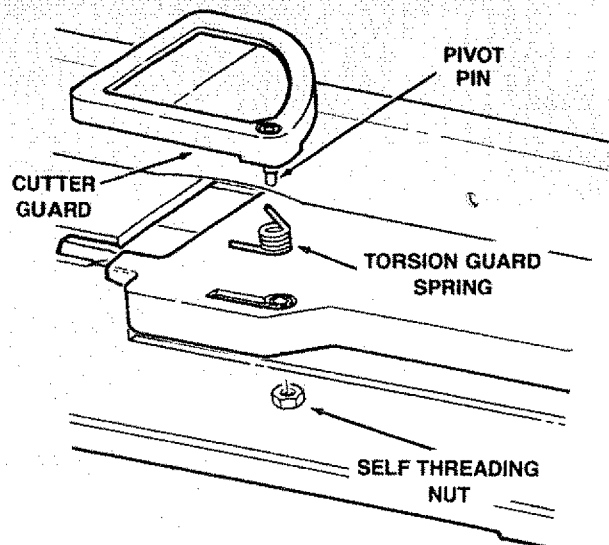

5. RAISE the end of the FENCE, rotate the guard COUNTER clockwise only enough to CLEAR fence.
6. LOWER the fence and tighten both knobs.

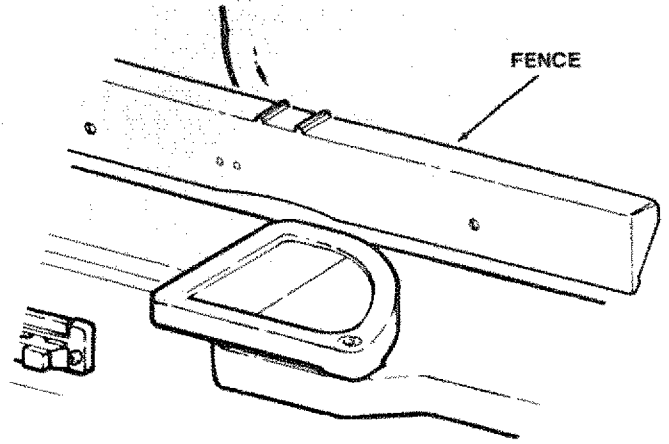

The normal position of the guard (at REST) when the fence is stationed at MAXIMUM WIDTH OF CUT, is shown as position "A". NEVER ROTATE GUARD BEYOND POSITION "B" BECAUSE THIS WOULD EXERT EXCESSIVE TENSION ON SPRING WHICH COULD WEAKEN OR BREAK IT.

Check operation of GUARD and SPRING.

1. With fence in MAXIMUM WIDTH OF CUT position, pass a piece of 1/4 in. thick wood on edge (jointing position) over cutterhead.
2. The guard should return automatically to its REST position against the fence when free of the wood.
3. If guard does not return to its REST position, remove the guard by following steps 1 thru 6 above. Make sure the spring is installed correctly and not broken. If the spring is broken it must be replaced.

Reassemble the guard and spring and test again by following steps 1 and 2.

If guard still does not return to its REST position, consult your local Sears Retail Store before using the jointer planer.

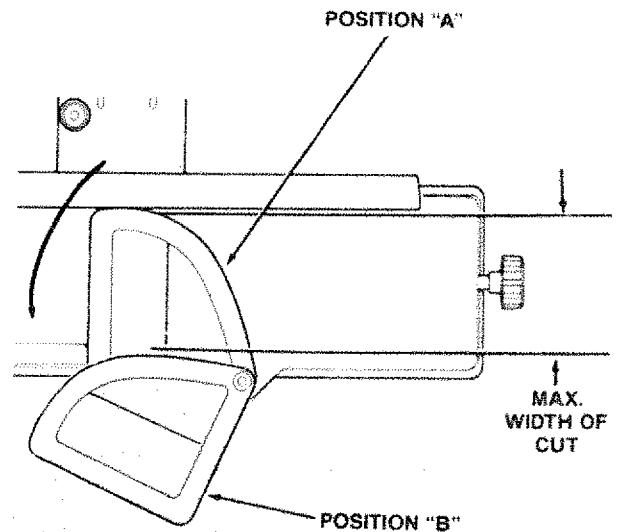

Lubrication

The BALL BEARINGS in this machine are packed with grease at the factory. They require no further lubrication.

The following parts should be oiled occasionally with SAE No. 20 or No. 30 engine oil.

1. Dovetail spacer and dovetail slide.
2. Elevating screw (first clean with Craftsman Gum and Pitch Remover).

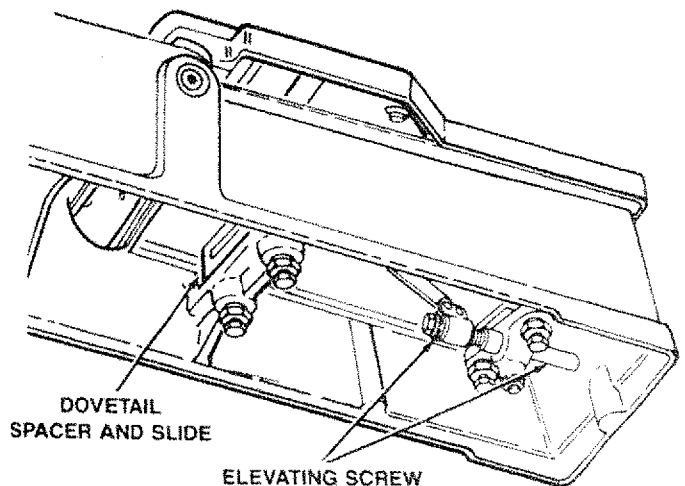

VIEW LOOKING UP FOR PARTS IDENTIFICATION

trouble shooting

WARNING: FOR YOUR OWN SAFETY, TURN SWITCH "OFF" AND REMOVE PLUG FROM POWER SOURCE OUTLET BEFORE TROUBLE SHOOTING YOUR JOINTER-PLANER.

TROUBLE SHOOTING CHART

TROUBLE	PROBABLE CAUSE	REMEDY
Motor will not run.	<ol style="list-style-type: none"> 1. Defective On-Off switch. Defective relay. Defective capacitor. Defective motor. Low line voltage. Belt tension too high. 	<p>Consult Sears Service. Any attempt to repair this electrical device may create a HAZARD unless repair is done by a qualified service technician. Repair service is available at your nearest Sears store.</p> <p>Adjust belt tension.</p>
Wood strikes outfeed table after passing over cutter head.	Blades improperly adjusted below surface of outfeed table.	Re-adjust blades, see Maintenance section.
Ripples on planed surface. Kickbacks.	<ol style="list-style-type: none"> 1. One blade set higher than other. 2. Feeding wood too fast. 3. Cutting knives are set too high above outfeed table, or they are not leveled with outfeed table. 	<ol style="list-style-type: none"> 1. Re-adjust blades, see Maintenance section. 2. Feed wood slower. 3. Re-adjust blades, see Maintenance section.
Planed surface not straight.	Infeed table out of adjustment.	Re-adjust infeed table, see Getting To Know Your Jointer/Planer section.
Excessive gouging at end of cut.	Blades set too high above outfeed table.	Reset blades, see Maintenance section.
90° and 45° cuts inaccurate.	<ol style="list-style-type: none"> 1. Fence stops not adjusted properly. 2. Fence bottom not even with outfeed table due to wood chips under slide. 	<ol style="list-style-type: none"> 1. Re-adjust fence stops, see Getting To Know Your Jointer/Planer section. 2. Clean wood chips from underside of fence.
Infeed table loose.	1. 5/16"-18 lockbolt loose.	1. Tighten lockbolts.
Cutter guard does not function properly.	1. Return spring broken, or spring has been weakened.	Consult Sears Service immediately. Any attempt to repair this guard may create a hazard unless repair is done by a qualified service technician. Repair service is available at your nearest Sears store.

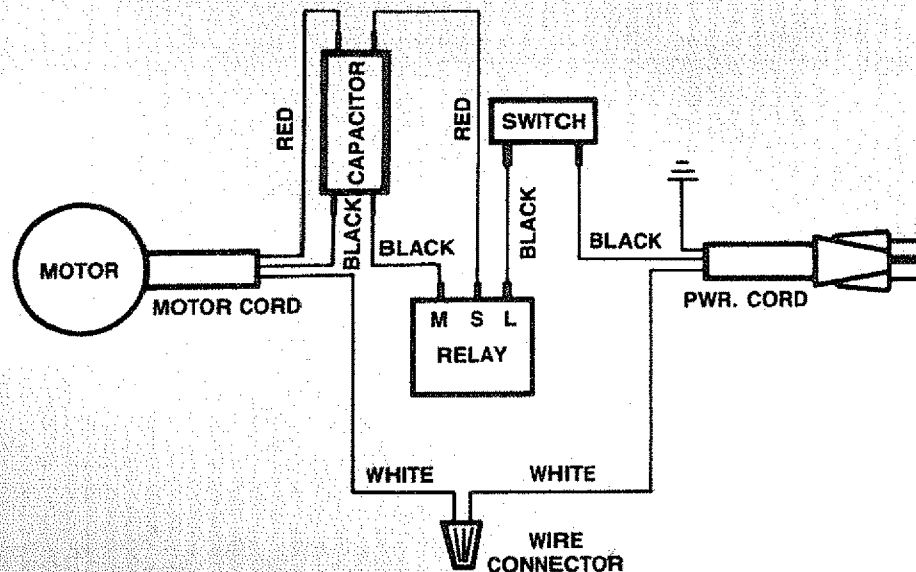

TROUBLE SHOOTING — MOTOR

NOTE: Motors used on wood-working tools are particularly susceptible to the accumulation of sawdust and wood chips and should be blown out or "vacuumed" frequently to prevent interference with normal motor ventilation.

TROUBLE	PROBABLE CAUSE	REMEDY
Excessive noise.	<ol style="list-style-type: none"> 1. Motor. 2. Pulley setscrew loose. 	<ol style="list-style-type: none"> 1. Have motor checked by qualified service technician. Repair service is available at your nearest Sears store. 2. Tighten setscrew.
Motor fails to develop full power. NOTE: LOW VOLTAGE: (Power output of motor decreases rapidly with decrease in voltage at motor terminals. For example, a reduction of 10% in voltage causes a reduction of 19% in maximum power output of which the motor is capable, and a reduction of 20% in voltage causes a reduction of 36% in maximum power output.)	<ol style="list-style-type: none"> 1. Circuit overloaded with lights, appliances and other motors. 2. Undersize wires or circuit too long. 3. General overloading of power company facilities. 	<ol style="list-style-type: none"> 1. Do not use other appliances or motors on same circuit when using the jointer. 2. Increase wire sizes, or reduce length of wiring. See "Motor Specifications and Electrical Requirements" section. 3. Request a voltage check from the power company.
Motor starts slowly or fails to come up to full speed.	<ol style="list-style-type: none"> 1. Low voltage will not trip relay. 2. Windings burned out or open. 3. Starting relay not operating. 4. Drive belt tension too high. 	<ol style="list-style-type: none"> 1. Request voltage check from the power company. 2. Have motor repaired or replaced. 3. Have relay replaced. 4. Adjust belt tension.
Motor overheats.	<ol style="list-style-type: none"> 1. Motor overloaded. 2. Improper cooling. (Air circulation restricted through motor due to sawdust accumulating inside of motor.) 3. Defective relay. 	<ol style="list-style-type: none"> 1. Feed work slower into blade. 2. Clean out sawdust to provide normal air circulation through motor. See "Maintenance and Lubrication" section. 3. Have relay replaced.
Motor stalls (resulting in blown fuses or tripped circuit breakers.)	<ol style="list-style-type: none"> 1. Relay or capacitor not operating. 2. Voltage too low to permit motor to reach operating speed. 3. Fuses or circuit breakers do not have sufficient capacity. 	<ol style="list-style-type: none"> 1. Have relay and/or capacitor replaced. 2. Request voltage check from the power company. 3. Install proper size fuses or circuit breakers. See electrical connection section.
Frequent opening of fuses or circuit breakers.	<ol style="list-style-type: none"> 1. Motor overloaded. 2. Fuses or circuit breakers do not have sufficient capacity. 	<ol style="list-style-type: none"> 1. Feed work slower. 2. Install proper size fuses or circuit breakers. See electrical connection section.

SEARS RECOMMENDS THE FOLLOWING ACCESSORIES

ITEM	CAT. NO.
Cutter Blades	9-2293
Power Tool Know-how Handbook	9-29117
Knife Setting Gauge	9-2647
Chip Collector	9-29974

Sears may recommend other accessories not listed in the manual. See your nearest Sears store or Catalog department for other accessories.

Do not use any accessory unless you have received and read complete instructions for its use.

repair parts

PARTS LIST FOR CRAFTSMAN 6-1/8-INCH JOINTER-PLANER MODEL NO. 113.232210

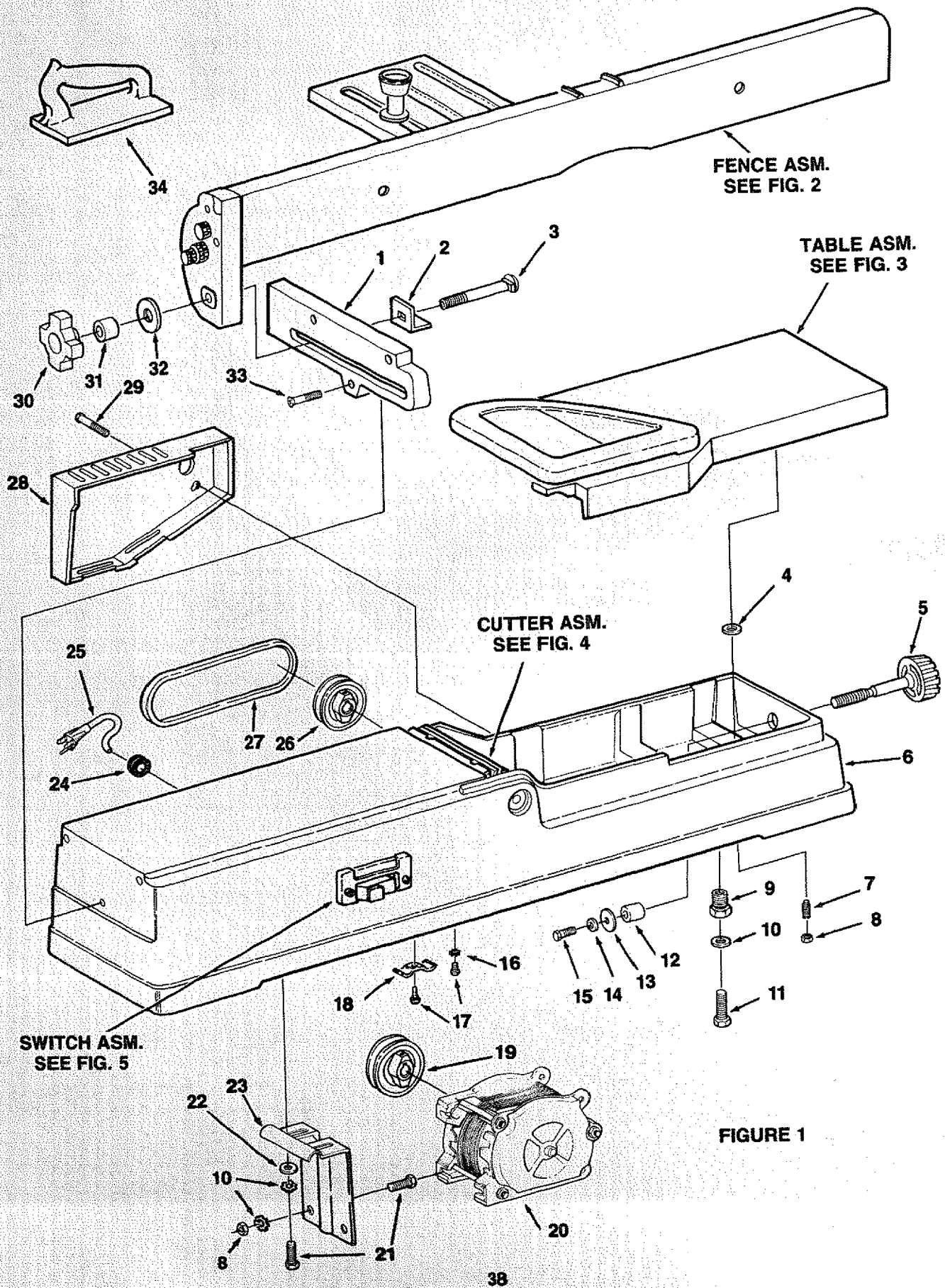

FIGURE 1

repair parts

PARTS LIST FOR CRAFTSMAN 6-1/8-INCH JOINTER-PLANER MODEL NO. 113.232210

Always order by Part Number — Not by Key Number

FIGURE 1 — JOINTER ASSEMBLY

Key No.	Part No.	Description
1	21237	Bracket Fence Slide
2	21738	Retainer Bolt
3	STD533725	*Bolt-Crg 3/8-16 x 2-1/2
4	18437	Washer
5	818099	Knob Elevation
6	820081	Base-Jointer/Planer
7	102832	Screw-SL Set 5/16-18 x 1
8	STD541031	*Nut-Hex 5/16-18
9	18516	Stud-Leveling
10	STD551131	*Lockwasher-5/16
11	STD523117	*Screw-Hex 5/16-18 x 1-3/4
12	67017	Spacer
13	STD551025	*Washer-17/64 x 3/4 x 7/64
14	STD551225	*Lockwasher-1/4
15	STD522505	*Screw-hex Hd 1/4-20 x 1/2
16	STD551210	*Lockwasher-Ext 10
17	STD511103	*Screw-Pan Hd 10-32 x 3/8
18	63418	Clamp-Cord
19	STD328022	*Pulley
20	820074	Motor
21	60025	Screw-Hex Hd 5/16-18 x 3/4

Key No.	Part No.	Description
22	STD551031	*Washer-21/64 x 5/8 x 1/16
23	818098	Support-Motor
24	806196-3	Grommet-Rubber
25	816573	Cord w/Plug
26	STD328012	*Pulley
27	STD304210	*Belt-V4L 21 inch
28	818100	Guard-Belt
29	808277-1	Screw-Pan Hd 10-32 x 2-3/4
30	62331	Knob-Lock
31	47624	Spacer
32	STD551037	*Washer-.380 x 19/64 x 7/64
33	132275	Screw-Fil Hd 1/4-20 x 1
34	67062	Block-Push
—	508091	Bag of Loose Parts (Not Illustrated)
—	508093	Bag of Loose Parts (Not Illustrated)
—	508210	Bag of Loose Parts (Not Illustrated)
—	SP5447	Owners, Manual (Not Illustrated)

* Standard Hardware Item — May Be Purchased Locally.

repair parts

PARTS LIST FOR CRAFTSMAN 6-1/8-INCH JOINTER-PLANER MODEL NO. 113.232210

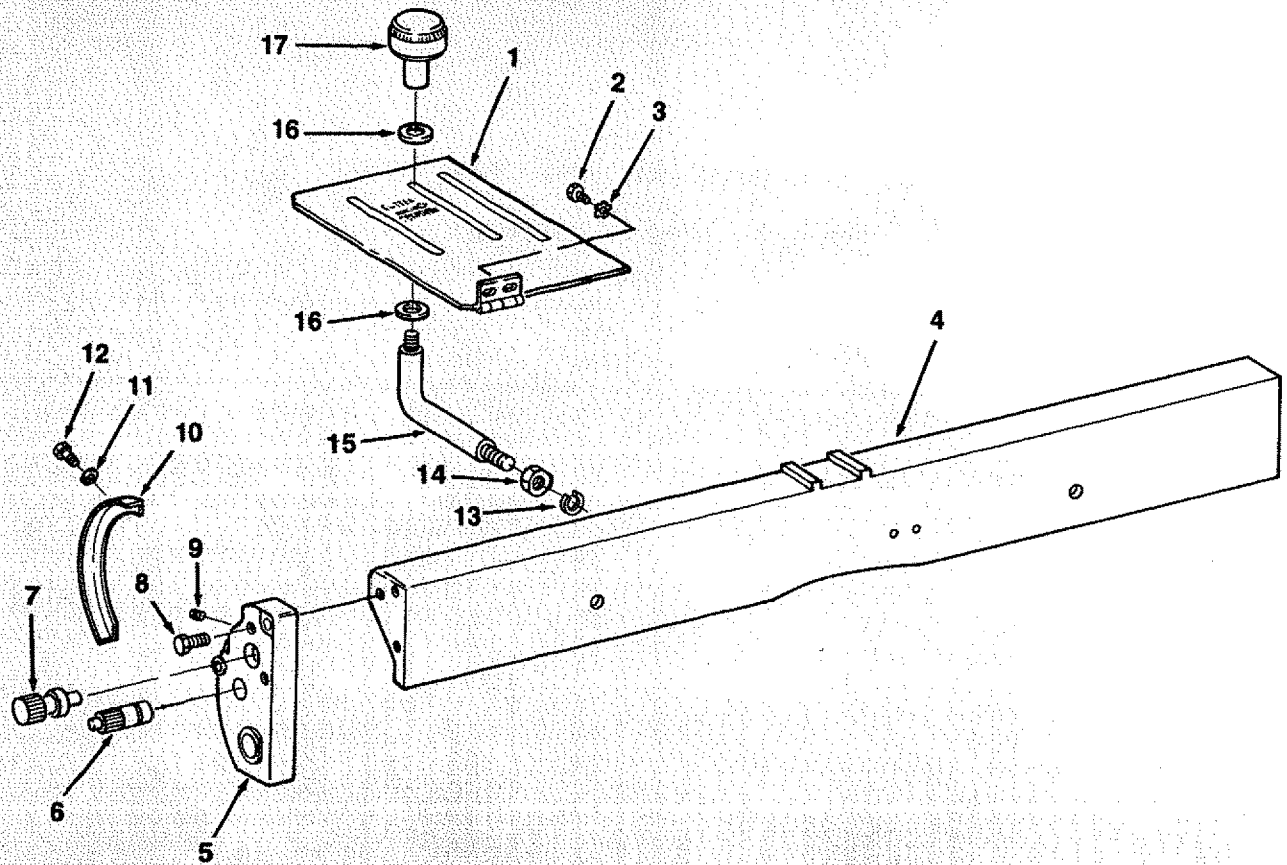

Always order by Part Number — Not by Key Number

FIGURE 2 — FENCE ASSEMBLY

Key No.	Part No.	Description
1	67009	Guard-Cutter
2	STD511102	*Screw-Pan Hd 10-32 x 1/4
3	STD551210	*Lockwasher-Ext. #10
4	818103	Fence
5	21232	Plate-Fence End
6	21440	Plunger Assembly
7	21430	Pin Assembly-Stop
8	STD522512	*Screw-Hex Hd 1/4-20 x 1-1/4
9	102817	Screw-SL Set 1/4-20 x 1/2
10	21736	Scale-Fence Tilt

Key No.	Part No.	Description
11	STD551010	*Washer 13/64 x 1/2 x 3/64
12	STD510802	*Screw-Bind Hd 8-32 x 1/4
13	STD551150	*Lockwasher-1/2
14	STD541050	*Nut-Hex Jam 1/2-13
15	818104	Rod-Sliding Guide
16	21622	Washer-Sliding Guard
17	67020	Knob-Sliding Guard

* Standard Hardware Item — May Be Purchased Locally.

repair parts

PARTS LIST FOR CRAFTSMAN 6-1/8-INCH JOINTER-PLANER MODEL NO. 113.232210

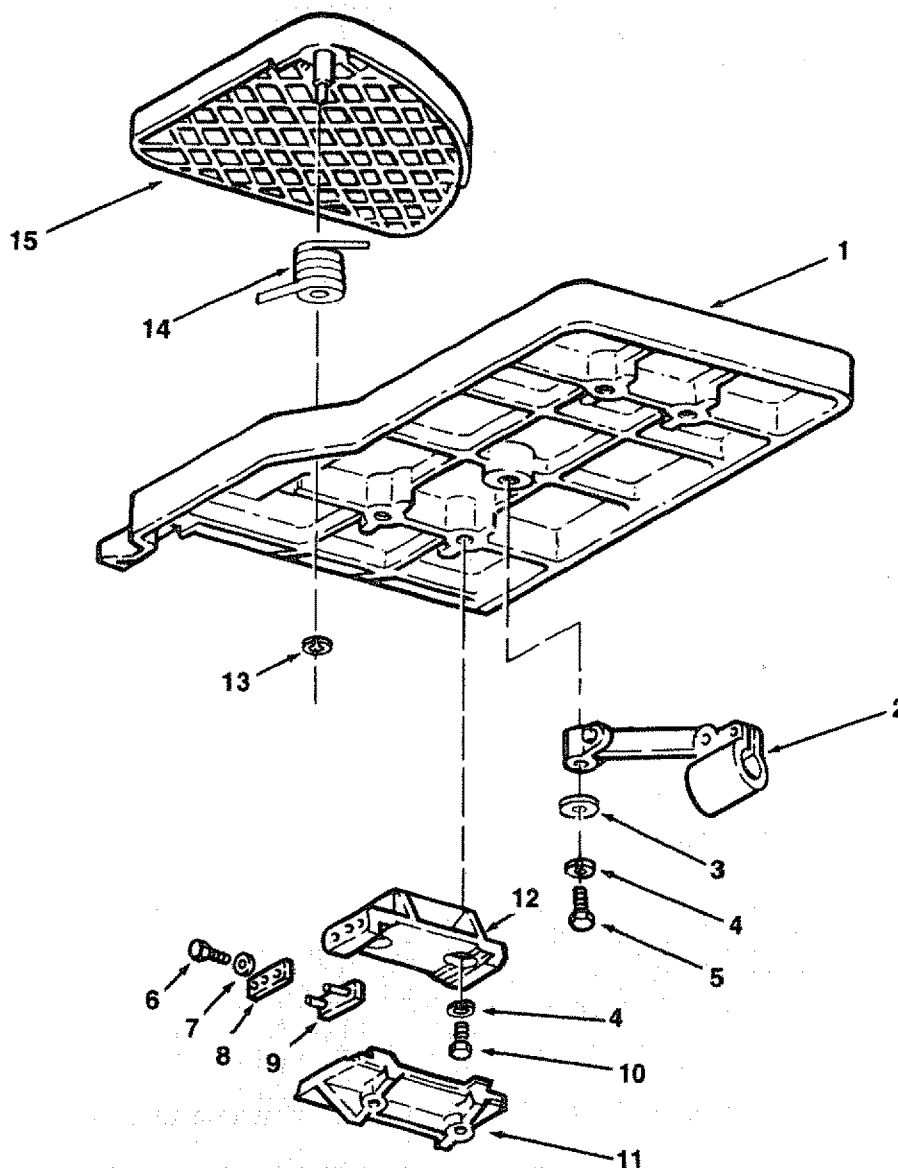

Always order by Part Number — Not by Key Number

FIGURE 3 — TABLE ASSEMBLY

Key No.	Part No.	Description
1	818101	Table-Front
2	21204	Linkage-Assembly
3	STD551031	*Washer-11/32 x 11/16 x 1/16
4	STD551131	*Lockwasher-5/16
5	STD523112	*Screw-Hex Hd 5/16-18 x 1-1/4
6	STD522505	*Screw-Hex Hd 1/4-20 x 1/2
7	STD551025	Washer-17/64 x 47/64 x 1/16

Key No.	Part No.	Description
8	21812	Plate-Tension
9	21422	Spacer-Dovetail
10	21635	Screw-Special
11	21219	Guide-Male
12	21218	Guide-Female
13	60388	Nut-Self Threading
14	817734	Spring-Torsion Guard
15	816871	Guard

* Standard Hardware Item — May Be Purchased Locally.

repair parts

PARTS LIST FOR CRAFTSMAN 6-1/8-INCH JOINTER-PLANER MODEL NO. 113.232210

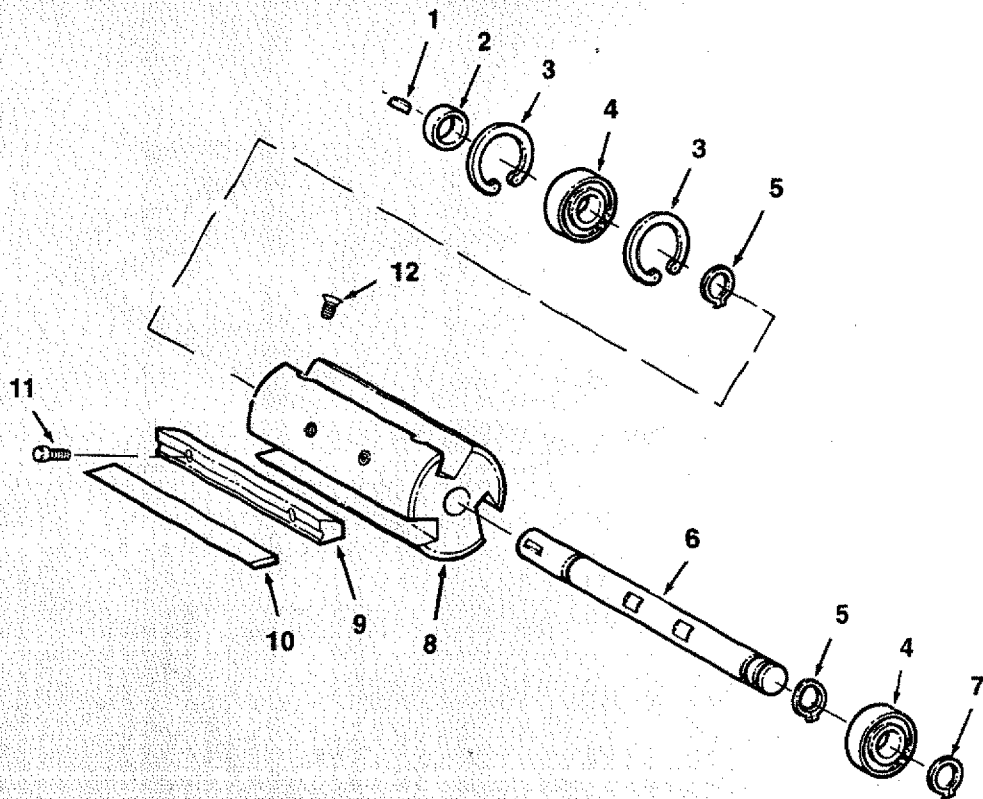

Always order by Part Number — Not by Key Number

FIGURE 4 — CUTTER ASSEMBLY

Key No.	Part No.	Description
1	STD580025	*Key Woodruff
2	802392-37	Spacer
3	18441	Ring-Retaining 5000-137
4	3509	Bearing-Ball 5/8 I.D.
5	STD582062	*Ring-Retaining 5/8
6	816902	Arbor
7	37158	Ring-Retaining Bowed 5/8

Key No.	Part No.	Description
8	21450	Head Asm.-Complete Cutter
9	21632	Wedge
10	9-2293	†Blade
11	60116	Screw-Soc Cap 10-32 x 3/4
12	60118	Screw Flat Hd Soc 10-32 x 1/2

* Standard Hardware Item — May Be Purchased Locally.

† Stock Item — May Be Secured Through The Hardware Department Of Most Sears Retail or Catalog Order Houses.

repair parts

PARTS LIST FOR CRAFTSMAN 6-1/8-INCH JOINTER-PLANER MODEL NO. 113.232210

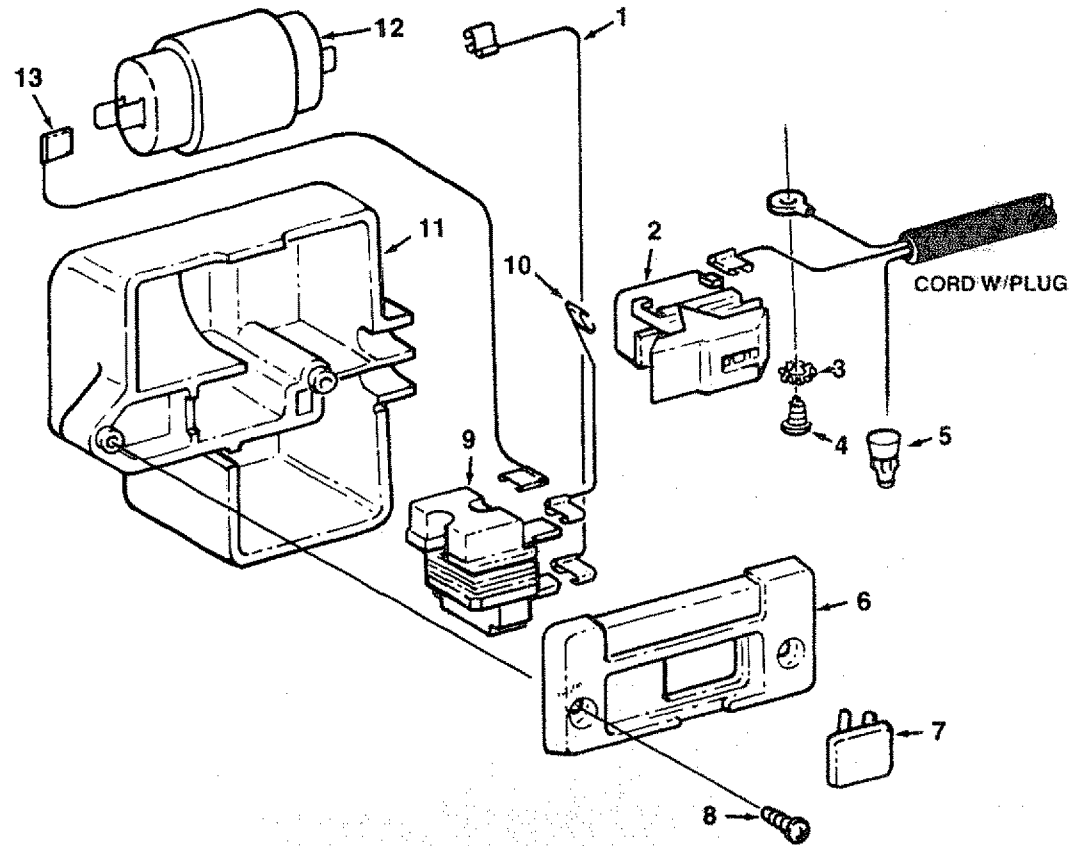

Always order by Part Number — Not by Key Number

FIGURE 5 — SWITCH ASSEMBLY

Key No.	Part No.	Description
1	816924-1	Lead
2	816113	Switch-Locking
3	STD551210	*Lockwasher-Ext #10
4	STD511103	*Screw-Pan Hd 10-32 x 3/8
5	803709	Connector-Wire
6	816880	Bezel-Switch
7	9-22256	†Key-Switch

Key No.	Part No.	Description
8	816274-2	Screw-Pan Hd #10 x 1
9	817399-6	Relay Model 101
10	816560-1	Lead-Jumper
11	816881	Housing-Switch
12	820075	Capacitor-Dry Film
13	816560-2	Lead-Jumper

* Standard Hardware Item — May Be Purchased Locally.

† Stock Item — May Be Secured Through The Hardware Department Of Most Sears Retail or Catalog Order Houses.

repair parts

PARTS LIST FOR CRAFTSMAN 6-1/8-INCH JOINTER-PLANER MODEL NO. 113.232210

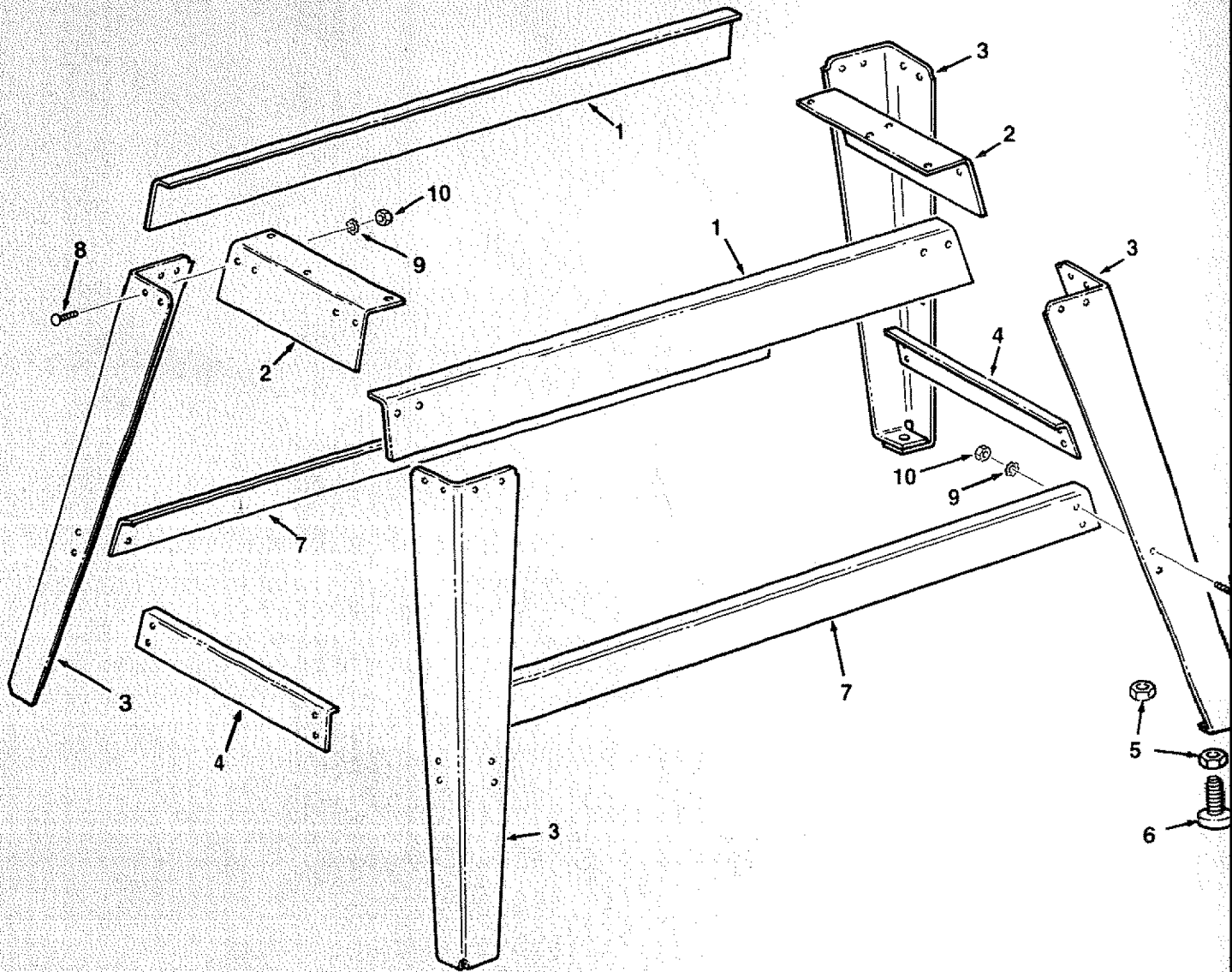

Always order by Part Number—Not by Key Number

FIGURE 6 — LEG SET ASSEMBLY

Key No.	Part No.	Description
1	816911	Stiffener-Leg
2	818096	Stiffener-Leg
3	817105	Leg
4	818097	Stiffener-Lower
5	STD541237	*Nut-Hex Jam 3/8-16
6	803835-1	Foot-Leveling

Key No.	Part No.	Description
7	816908	Stiffener-Lower
8	805589-5	Screw-Truss Hd 1/4-20 x 1/2
9	STD551225	*Lockwasher-Ext. 1/4
10	STD541025	*Nut-Hex 1/4-20
—	507711	Bag of Loose Parts (Not Illustrated)

* Standard Hardware Item May Be Purchased Locally.

SEARS

**owner's
manual**

SERVICE

**MODEL NO.
113.232210**

**JOINTER/PLANER WITH
LEGS AND MOTOR**

**HOW TO ORDER
REPAIR PARTS**

Contractor

6-1/8 INCH JOINTER-PLANER

Now that you have purchased your jointer-planer, should a need ever exist for repair parts or service, simply contact any Sears Service Center and most Sears, Roebuck and Co. stores. Be sure to provide all pertinent facts when you call or visit.

The model number of your 6-1/8 inch jointer-planer will be found on a plate attached to the base.

WHEN ORDERING REPAIR PARTS, ALWAYS GIVE THE FOLLOWING INFORMATION:

PART NUMBER

PART DESCRIPTION

MODEL NUMBER
113.232210

NAME OF ITEM
6-1/8 INCH JOINTER-PLANER

All parts listed may be ordered from any Sears Service Center and most Sears stores. If the parts you need are not stocked locally, your order will be electronically transmitted to a Sears Repair Parts Distribution Center for handling.

Sold by SEARS, ROEBUCK AND CO., Chicago, IL 60684 U.S.A.

Part No. SP5447

Form No. SP5447

Printed in Taiwan 8/90