

Save This Manual
For Future Reference

SEARS

owner's
manual

Model No.
113.232240
Jointer/Planer
with Legs and Motor

Serial
Number _____

Model and serial numbers
may be found on the back of
the jointer base.

You should record both model
and serial number in a safe
place for future use.

**FOR YOUR
SAFETY**
**READ ALL
INSTRUCTIONS
CAREFULLY**

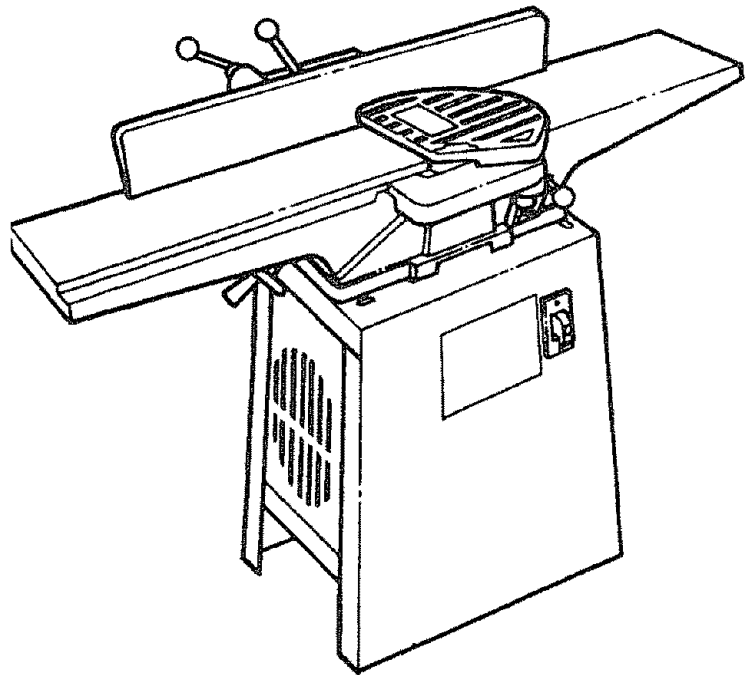

CRAFTSMAN® **CONTRACTOR SERIES** **6-1/8 INCH** **JOINTER/PLANER**

- assembly
- operating
- repair parts

Sears, Roebuck and Co., Hoffman Estates, IL. 60179 U.S.A.

FULL ONE YEAR WARRANTY ON CRAFTSMAN STATIONARY TOOL

If, this stationary tool fails due to a defect in material or workmanship within one year from the date of purchase, CONTACT THE NEAREST SEARS SERVICE CENTER IN THE UNITED STATES and Sears will repair it, free of charge.

This warranty applies only while this product is in the United States.

If this jointer/planer is used for commercial or rental purposes, this warranty will apply for ninety days from the date of purchases.

This warranty gives you specific legal rights, and you may also have other rights which vary from state to state.

Sears, Roebuck and Co., D/817 WA Hoffman Estates, IL. 60179

Safety Instructions For Jointer/Planer

Safety is a combination of common sense, staying alert and knowing how your jointer/planer works. Read this manual to understand this tool.

Safety Signal Words

DANGER: means if the safety information is not followed someone **will** be seriously injured or killed.

WARNING: means if the safety information is not followed someone **could** be seriously injured or killed.

CAUTION: means if the safety information is not followed someone **may** be injured.

Before Using the Jointer/Planer

WARNING: To avoid mistakes that could cause serious, permanent injury, do not plug the jointer/planer in until the following steps have been satisfactorily completed.

- Find and read the warning label found on the jointer/planer (shown below).

Know and Understand the Jointer/Planer

- Completely assemble and align jointer/planer.
- Learn the use and function of the ON-OFF switch, fence slide locking handle, cutter guard, depth of cut hand wheel, locks and stops, fence bevel lock handle, outfeed table, infeed table and hold-down/push-blocks.
- Review and understand all safety instructions and operating procedures in this manual.
- Review the maintenance methods for this jointer/planer.

WARNING
1. Read manual before using jointer.
2. Wear safety goggles that meet ANSI Z87.1 Standards.
3. Never perform jointing, planing, or rabbeting cuts with cutterhead guard or belt guards removed.
4. Never make jointing or planing cuts greater than 1/8 inch.
5. Always use push blocks for jointing material narrower than 3 inches or planing material thinner than 3 inches.
6. Never perform jointing, planing, or rabbeting cuts on workpieces shorter than 12 inches in length.
7. Turn power off and wait for blade to stop before adjusting or servicing.

When Installing Or Moving the Jointer/Planer

Avoid Dangerous Environment.

- Use the jointer/planer in a dry, indoor place protected from rain.
- Keep work area well lighted.

To avoid injury from unexpected jointer/planer movement.

- Bolt or clamp the jointer/planer to firm level surface where there is plenty of room for moving the workpiece through the entire cut.
- Support the jointer/planer so the tables are level and the jointer/planer does not rock.
- Put the jointer/planer where neither operators nor bystanders must stand in line with the wood while planing or jointing it.

- To avoid injury from electrical shock, make sure your fingers do not touch the plug's metal prongs when plugging in or unplugging the jointer/planer.
- Turn off and unplug the jointer/planer before moving it to a new area. To avoid back injury, get help when you need to lift or move the jointer/planer.
- Bolt the jointer/planer to the floor if it tends to slip, walk, slide or tip over. Be especially aware of movement when jointing/planing long heavy boards.
- **Never Stand On Tool.** Serious injury could occur if the tool tips or you accidentally hit the cutter head. Do not store anything above or near the tool where anyone might stand on the tool to reach them.

Before Each Use

Inspect your jointer/planer.

WARNING: The 2-1/2 inch jointer/planer pulley and the 3-1/2 inch motor pulley furnished will run the cutter head at about 5000 RPM when used with a 3450 RPM motor. Use of different types of pulleys or motors will change this speed and could cause jamming, binding, kickback, thrown knives or other dangers.

- To avoid injury from accidental starting, turn the switch off, unplug the saw, and remove the switch key before moving the cutter head guard, changing the blades, changing the setup, or adjusting anything.
- Check for alignment of moving parts, binding of moving parts, breakage of parts, unit stability, and any other conditions that may affect the way the jointer/planer works.
- If any part is missing, bent or broken in any way, or any electrical part does not work properly, turn the jointer/planer off and unplug the jointer/planer.
- Replace damaged, missing or failed parts before using the jointer/planer again.
- Make sure the cutter guard works properly. With the

switch off and key removed, pull the cutter guard open and let go. If the guard doesn't smoothly swing closed, contact Sears Service Department.

- Make sure the cutter head turns in the right direction. The top should move toward the infeed table. If the cutter head turns the wrong direction, contact Sears Service Department.
- Keep Jointer/Planer interior free of wood chips and dust buildup around motor and switch box.
- Keep knives sharp. Dull or nicked knives tend to "pound" and chew at the wood, causing kickbacks.
- To avoid injury from unsafe accessories, use only recommended accessories.

Use Recommended Accessories.

- To avoid injury from unsafe accessories, use only recommended accessories.
- Consult the owners manual for recommended accessories.
- Follow the instructions that accompany the accessories.

WARNING: Use only accessories recommended for this jointer/planer. (Using other accessories may be dangerous.)

To Avoid Injury From Jams, Slips Or Thrown Pieces (Kickbacks Or Throwbacks)

- Use this jointer/planer to cut only wood.
- Plan your hand placement so your fingers will not be anywhere a sudden slip could cause them to slide or fall into the cutter head. When using only one hold-down/push-block to feed the wood, do not put your other hand on the jointer/planer, workpiece, or hold-down/push-block.
- To avoid injury from thrown pieces, make sure the knives are sharp, properly installed and the cutter knives wedge screws are tight.
- Make sure the clamps and locks are tight and there is not excessive play in any parts.
- Adjust the depth of cut to between 1/32 and 1/16 of an inch for best results in most operations. A deep cut makes feeding the wood harder and can cause the wood to kickback. To be sure you will make a depth of

cut you planned, always lower the infeed table slightly farther than you wanted then, raise the table to the desired depth.

- Use The Right Tool. Don't force tool or attachment to do a job it was not designed for.

Inspect your work area.

- Keep work area clean.
- Cluttered areas and benches invite accidents.
- Floor must not be slippery from wax or sawdust.
- To avoid burns or other fire damage, never use the jointer/planer near flammable liquids, vapors or gases.
- Before using the jointer/planer, clear the table of all objects not needed to feed the workpiece.
- To avoid injury, don't do any layout, assembly, or setup work on the jointer/planer bed.

Plan Ahead To Protect Your Eyes, Hands, Face and Ears

Avoid Accidental Starting.

- Make sure switch is "OFF" before plugging jointer/planer into a power outlet.

Dress for safety.

- Do not wear loose clothing, gloves, neckties or jewelry (rings, wrist watches). They can get caught and draw you into moving parts.
- Wear nonslip footwear.
- Tie back long hair.
- Roll long sleeves above the elbow.
- Noise levels vary widely. To avoid possible hearing damage, wear ear plugs or muffs when using jointer/planer for hours at a time.

- Any jointer/planer can throw foreign objects into the eyes. This can result in permanent eye damage. Wear safety goggles (not glasses) that comply with ANSI Z87.1 (shown on package). Everyday eyeglasses have only impact resistant lenses. They are not safety glasses. Safety goggles are available at Sears retail stores. Glasses or goggles not in compliance with ANSI Z87.1 could seriously hurt you when they break.



- For dusty operations, wear a dust mask along with safety goggles.

Safety Instructions For Jointer/Planer (continued)

Inspect your workpiece.

- Make sure there are no nails or foreign objects in the part of the workpiece to be cut.

Plan your cut.

- Small or thin workpieces can kickback when they tip over on the tables or into the cutter head. To avoid head contact or workpiece kickback:
 - Never joint, plane or bevel workpieces shorter than 12 inches.
- When jointing, beveling or rabbeting:
 - Never joint or bevel workpieces less than 3/4 inch wide or 1/4 inch thick.
 - Always use the hold-down/push-blocks when jointing or beveling wood narrower than 3 inches.
 - When rabbeting, always make cuts in 1/8" increments or less.
- When planing:
 - Never plane wood thinner than 1/2 inch.
 - Always use hold-down/push-blocks when planing wood thinner than 3 inches.

- Never cut **Freehand**. Guide your workpiece solidly against the fence and table top.
- Make sure there's no debris between the workpiece and its supports.

Use extra caution with large, very small or awkward workpieces.

- Use extra supports (tables, saw horses, blocks, etc.) for any workpiece large enough to tip when not held down to the table top. Never use another person as additional support or to help feed, support or pull the workpiece.
- Never cut more than one workpiece at a time.
- Never turn your jointer/planer "ON" before clearing everything except the workpiece and related support devices off the table.
- Before trying a new or little used operation, carefully plan your hand placement. Make sure you have proper hold-down/push-blocks, jigs, fixtures, stops, etc. ready to use.

Whenever Jointer/Planer Is Running:

WARNING: Don't allow familiarity (gained from frequent use of your jointer/planer) cause a careless mistake. Always remember that a careless fraction of a second is enough to cause a severe injury.

- Before actually cutting with the jointer/planer, let it run for a while. If it makes an unfamiliar noise or vibrates a lot, stop immediately. Turn the jointer/planer off. Unplug the jointer/planer. Do not restart until finding and correcting the problem.

Keep Children Away.

- Keep all visitors a safe distance from the jointer/planer.
- Make sure bystanders are clear of the jointer/planer and workpiece.

Don't Force Tool.

- Let the cutter head reach full speed before cutting.
- Feed the workpiece into the jointer/planer only fast enough to let the tool cut without bogging down or binding.

Before freeing jammed material.

- Turn switch "OFF".
- Wait for all moving parts to stop.
- Unplug the jointer/planer.
- Check knives for sharpness and nicks before starting again.

Before Leaving the Jointer/Planer.

- Turn the jointer/planer off.
- Wait for knives to come to a complete stop.
- Unplug the jointer/planer.

- Make workshop child-proof. Lock the shop. Disconnect master switches. Remove the yellow switch key. Store it away from children and others not qualified to use the tool.

Glossary of Terms for Woodworking

Bed

The combination of infeed and outfeed table surfaces which support the workpiece during a cutting operation.

Bevel/Chamfer

Removing wood along the edge of a board to make that edge straight, smooth and angled to the board face which is against the fence.

Cutter Guard

Spring loaded guard or shield covering the cutter head.

Cutter Head

The cutter head is a rotating piece with three adjustable knives. The cutter head removes material from the workpiece.

Depth of cut

A term used to indicate how deep into the workpiece the cutter knives will cut.

Fence

The fence is attached to the jointer/planer base. The fence helps support and guide the workpiece as it is pushed across the cutter head.

Freehand

Using the tool without holding the workpiece firmly against the fence and table. This can let the workpiece twist and kick back and must never be attempted.

Gum

A sticky, sap based residue from wood products.

Hold-Down/Push-Blocks

They are required for your own safety. They are used to hold your workpieces against the table and fence when planing, rabbeting or jointing.

Infeed Table

The section of the jointer bed upon which the workpiece is placed before being pushed into the cutter head. Infeed table height is adjustable which allows the operator to select the depth of cut.

Jointing

The removal of wood along the edge of a board so as to make that edge straight, smooth and square to the board face which is against the fence.

Kickback

An uncontrolled grabbing and throwing of the workpiece back toward the operator by the rotating cutter head.

Leading End

The end of the workpiece which is pushed into the cutter head first.

Outfeed Table

The section of a jointer bed which supports the workpiece after it passes over the cutter head.

Planing

Removing wood from the widest surface or face of a board so as to make it flat and smooth.

Rabbet

A notch cut into the edge of workpiece.

Resin

A sticky, sap based substance that has hardened.

Revolutions Per Minute (RPM)

The number of turns completed by a spinning object in one minute.

Throw-Back

Throwing of pieces in a manner similar to a kickback.

Trailing End

The workpiece end last cut by the knives.

Workpiece

The item on which the cutting operation is being performed. The surfaces of a workpiece are commonly referred to as faces, ends and edges.

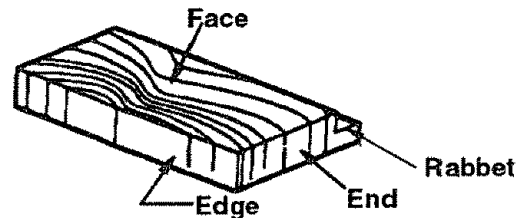

Motor Specifications and Electrical Requirements

Power Supply and Motor Specifications

WARNING: To avoid electrical hazards, fire hazards or damage to the tool, use proper circuit protection. Your tool is wired at the factory for operation using the voltage shown. Connect tool to a power line with the appropriate voltage and a 15-amp branch circuit. Use a 15-amp time delay type fuse or circuit breaker. To avoid shock or fire, if power cord is worn or cut, or damaged in any way, have it replaced immediately.

The A/C motor used on this tool is a capacitor start, non-reversible type, wired at the factory for 110-120V AC, 60 Hz. operation.

Follow the instructions on page 7 to connect the motor for 220-240V A/C operation.

Max. Dev. H.P	2-1/2	
Voltage	110-120	220-240
Amperes	12	6
Hertz (Cycles)	60	
Phase	Single	
RPM	3450	
Rotation of Shaft	Counterclockwise	

Wire Sizes

NOTE: Make sure the proper extension cord is used and is in good condition.

The use of any extension cord will cause some loss of power. To keep this to a minimum and to prevent overheating and motor burn-out, use the table shown to determine the minimum wire size (A.W.G.) extension cord.

Use only 3-wire extension cords which have 3-prong grounding type plugs and 3-pole receptacles which accept the tools plug.

Extension Cord Length	Wire Sizes Required for (A.W.G.)	
	110-120V	220-240V
0-25 Ft.	14	16
26-50 Ft.	12	14

Motor Specifications and Electrical Requirements (continued)

General Electrical Connections

DANGER: To avoid electrocution:

1. Use only identical replacement parts when servicing. Servicing should be performed by a qualified service technician.

2. Do not use in rain or where floor is wet.

This tool is intended for indoor residential use only.

In the event of a malfunction or breakdown, grounding provides a path of least resistance for electric current to reduce the risk of electric shock. This tool is equipped with an electric cord having an equipment grounding conductor and a grounding plug, as shown. The plug must be plugged into a matching outlet that is properly installed and grounded in accordance with all local codes and ordinances.

Do not modify the plug provided. If it will not fit the outlet, have the proper outlet installed by a qualified electrician.

A temporary adapter may be used to connect this plug to a 2-prong outlet, as shown. This temporary adapter should be used only until a properly grounded outlet can be installed by a qualified electrician. The green colored rigid ear, lug and the like, extension from the adapter must be connected to a permanent ground such as a properly grounded outlet box.

Improper connection of the equipment grounding conductor can result in a risk of electric shock. The conductor with insulation having an outer surface that is green with or without yellow stripes is the equipment grounding conductor. If repair or replacement of the electric cord or plug is necessary, do not connect the equipment-grounding conductor to a live terminal.

If the grounding instructions are not completely understood, or if you are in doubt as to whether the tool is properly grounded check with a qualified electrician or service personnel.

WARNING: If not properly grounded, this tool can cause an electrical shock, particularly when used in damp locations, in proximity to plumbing, or out of doors. If an electrical shock occurs there is the potential of a secondary hazard, such as your hands contacting the knives.

WARNING Do not permit fingers to touch the terminals of plug when installing or removing the plug to or from the outlet.

If power cord is worn or cut, or damaged in any way, have it replaced immediately.

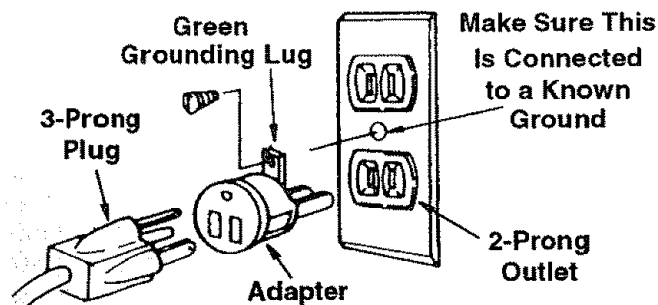
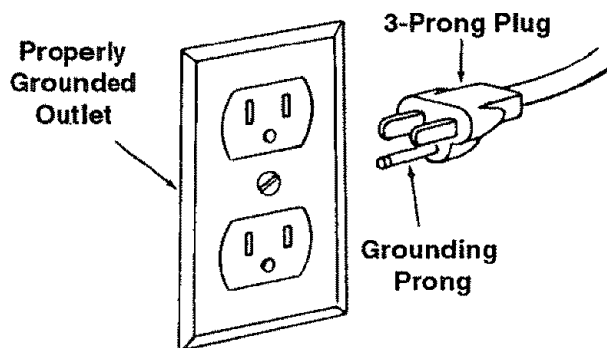

110-120 Volt, 60 Hz. Tool Connections

NOTE: The adapter illustrated is for use only if you already have a properly grounded 2-prong outlet.

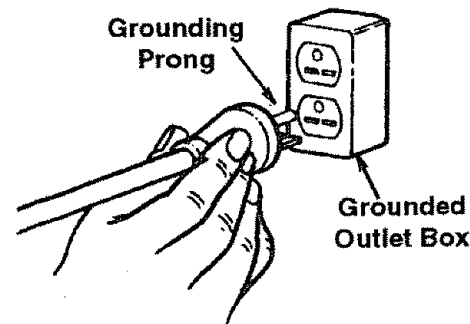

220-240 Volt, 60 Hz. Tool Connections

Changing Motor Voltage

WARNING: If not properly grounded, this tool can cause an electrical shock, particularly when used in damp locations, in proximity to plumbing, or out of doors. If an electrical shock occurs there is the potential of a secondary hazard, such as your hands contacting the knives.

NOTE: The jointer is prewired at the factory for 120V operation. Use the following procedure to change motor voltage. To change to 240V application an additional wire nut is supplied from the factory. This part is included in the loose parts.

1. Open the motor junction box cover located on the side of the motor.
2. Cut off the 120 volt power cord **plug** and replace it with a (3 blade) 240 volt 15 amp U.L. listed plug. (See illustration of 240V plug & receptacle.) Connect the power cord white and black leads, respectively, to the "hot" plug blade terminals and connect the power cord green grounding wire to the plug ground prong terminal.

3. Remove and discard the electrical tape from the wire nuts. Remove wire nuts.
4. Reconnect the leads as shown in the "Wiring Diagram" section at the rear of manual.
5. Reinstall the wire nuts and wrap with two layers of new U.L. listed electrical tape per wire nut.
6. Recheck your wiring to the wiring diagrams. Do this so you can be sure that the wiring is correct.
7. Reinstall the junction box cover.

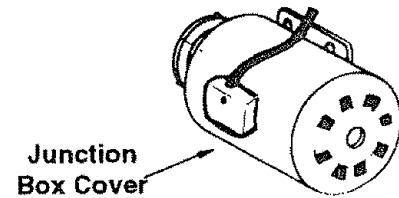

Motor Safety Protection

IMPORTANT: To avoid motor damage, this motor should be blown out or vacuumed frequently to keep sawdust from interfering with normal motor ventilation.

1. Connect this tool to a power source with the appropriate voltage for your model and a 15-amp branch circuit with a 15-amp time delay fuse or circuit breaker. Using the wrong size fuse can damage the motor.
2. If the motor won't start, turn off the power switch immediately and unplug the tool. Check the saw blade to make sure it turns freely. If the blade is free, try to start the motor again. If the motor still does not start, refer to the "Motor Troubleshooting Chart."
3. If the motor suddenly stalls while cutting wood, turn off the power switch, unplug the tool, and free the blade from the wood. The motor may now be restarted and the cut finished.

4. Fuses may "blow" or circuit breakers may trip frequently if:
 - a. **Motor Is Overloaded**-Overloading can occur if you feed too rapidly or make too many start/stops in a short time.
 - b. Line voltages should not be more than 10% above or below the nameplate voltage. For heavy loads, however, the voltage at motor terminals must equal the voltage specified for your model.
 - c. Improper or dull jointer knives are used.
5. Most motor troubles may be traced to loose or incorrect connections, overload, low voltage (such as small size wire in the supply circuit) or to overly long supply circuit wire. Always check the connections, the load and the supply circuit whenever motor doesn't work well. Check wire sizes and length with the Wire Size Chart.

Table of Contents

Safety Instructions For Jointer/Planer	2	Getting to Know Your Jointer/Planer	17-18
Safety Signal Words	2	Alignments	19-22
Before Using the Jointer/Planer	2	Cutter Knife Adjustments/Replacement	19
When Installing Or Moving the Jointer/Planer	2	Cutter Knife Sharpening	20
Before Each Use	3	Adjusting Table Extension	20
To Avoid Injury From Jams, Slips Or Thrown Pieces (Kickbacks Or Throwbacks)	3	Outfeed Table Adjustment	21
Plan Ahead To Protect Your Eyes, Hands, Face and Ears	3	Adjusting Table Gibs	22
Inspect your workpiece.	4	Fence Tilt (Bevel Stop) Alignment	22
Whenever Jointer/Planer Is Running:	4	Safety Instructions for Basic Jointer/Planer	
Before Leaving the Jointer/Planer.	4	Operation	23-24
Glossary of Terms for Woodworking	4	To Avoid Injury From Jams, Slips Or Thrown Pieces (Kickbacks Or Throwbacks):	23
Motor Specifications and Electrical Requirements ...	5-7	Plan Ahead to Protect Your Eyes, Hands, Face and Ears	23
Power Supply and Motor Specifications.....	5	Whenever Jointer/Planer Is Running:	24
Wire Sizes	5	Basic Jointer/Planer Cutting Operations	24-28
General Electrical Connections	6	Depth of Cut Handwheel Operation	24
Changing Motor Voltage	7	Stop Pin Operation	24
Motor Safety Protection	7	Feeding the Workpiece	24
Table of Contents	8	Planing	25
Unpacking and Checking Contents	8-11	Jointing	26
Tools Needed	8	Beveling/Chamfering	26
Unpacking	8	Rabbeting	26
Table of Loose Parts	9	Stop Pin Operation	26
List of Loose Parts	10	Support Long Workpieces	27
List of Loose Parts (From Bag Assembly)	11	Using the Hold-Down/Push-Blocks	27
Assembly	12-16	Sliding Fence Operation	28
Assemble The Stand	12	Fence Tilt Operation	28
Install the Leveling Feet	12	Maintenance and Lubrication	28-29
Installing Motor Brackets	12	Maintenance	28
Assemble Motor To Stand	13	Lubrication	29
Assemble Switchbox to Stand	14	Sears Recommends the Following Accessories	29
Assemble Bed to Stand	14	Recommended Accessories	29
Assemble Fence To Bed	15	Wiring Diagram	29
Install Cutter Head Guard	15	Troubleshooting Guide	30-31
Cutter Head Guard Functional Check	15	General	30
Adjusting Guard Spring	16	Motor	31
Attaching Pulley Guard	16	Repair Parts	32-38
Installing Rear Cutter Head Guard	16		
Adjusting the Leveling Feet	16		

Unpacking and Checking Contents

Tools Needed

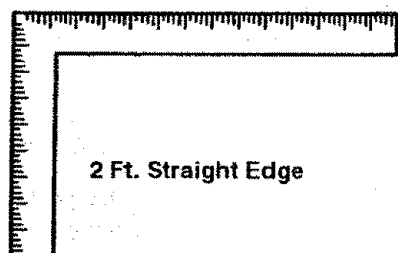

Phillips Screwdriver

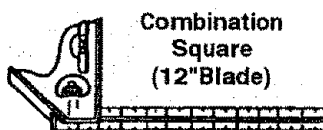

Adjustable Wrench

Combination Square must be true. Check its accuracy as shown.

Select the straight edge of a board. This edge must be perfectly straight.

Draw light line on board along edge

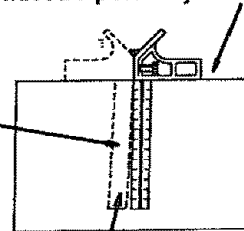

Should be no gap or overlap here when square is flipped over in dotted position

Unpacking

WARNING: To avoid injury from unexpected starting or electrical shock, do not plug the power cord into a power source outlet during unpacking, until all assembly steps are complete, and you have read and understand the safety and operating instructions.

WARNING: Although compact, this tool is heavy. To avoid back injury, get help whenever you have to lift the tool.

Your jointer/planer is shipped complete in one carton and includes steel legs.

1. Clear yourself a large work area. Remove the jointer/planer and parts from the carton. Lift the tool at the bottom of the base.
2. Place the tool on a secure, stationary work surface and look it over carefully.
3. Separate all parts from packing materials and check each one with the "Table of Loose Parts" and the "List of Loose Parts" to make certain all items are accounted for before discarding any packing material.

If you are missing any parts, check packing material for those items.

WARNING: If any parts are missing, do not attempt to assemble the jointer/planer. Do not plug in the power cord or turn the switch on until the missing parts are obtained and are installed correctly.

4. Contact your Sears Service Center to get the missing parts. Use the "Repair Parts" pages at the end of this manual to identify the part number of the missing parts after completing the "Unpacking and Checking Contents" section.
5. Remove the protective oil that is applied to all unpainted surfaces. Use any ordinary household type grease and spot remover.

WARNING: To avoid fire or health hazard, never use gasoline, naphtha, or similar highly volatile solvents.

6. Apply coat of paste wax to the tables and fence.
7. Wipe all parts thoroughly with a clean, dry cloth.

Table of Loose Parts

NOTE: Before beginning assembly, check that all parts are included. If you are missing any part, do not assemble the tool. Contact your Sears Service Center to get the missing part. Sometimes small parts can get lost in packaging material. Do not throw away any packaging until jointer/planer is put together. Check packaging for missing parts before contacting Sears. A complete parts list (Repair Parts) is at the end of the manual. Use the list to identify the number of the missing part.

The following parts are included:

Item	Part Name	Qty.
A	Jointer Bed Assembly	1
B	Fence	1
C	Motor	1
D	Motor Pulley w/Set Screws	1
E	V-Belt	1

F	Push Blocks	2
G	Top Panel	1
H	Stand Front Panel	1
J	Stand Rear Panel	1
K	Stiffeners	2
L	Lower Motor Bracket	1
M	Top Stiffener	1
N	Vertical Motor Bracket	1
P	Cutter Guard	1
Q	Pulley Guard	1
R	Handwheel	2
S	Cover	2
T	Rear Guard	1
U	Owner's Manual	1
V	Bag Loose Parts	*

* Quantity of bag may vary, bags may contain smaller bags

Unpacking and Checking Contents (continued)

List of Loose Parts

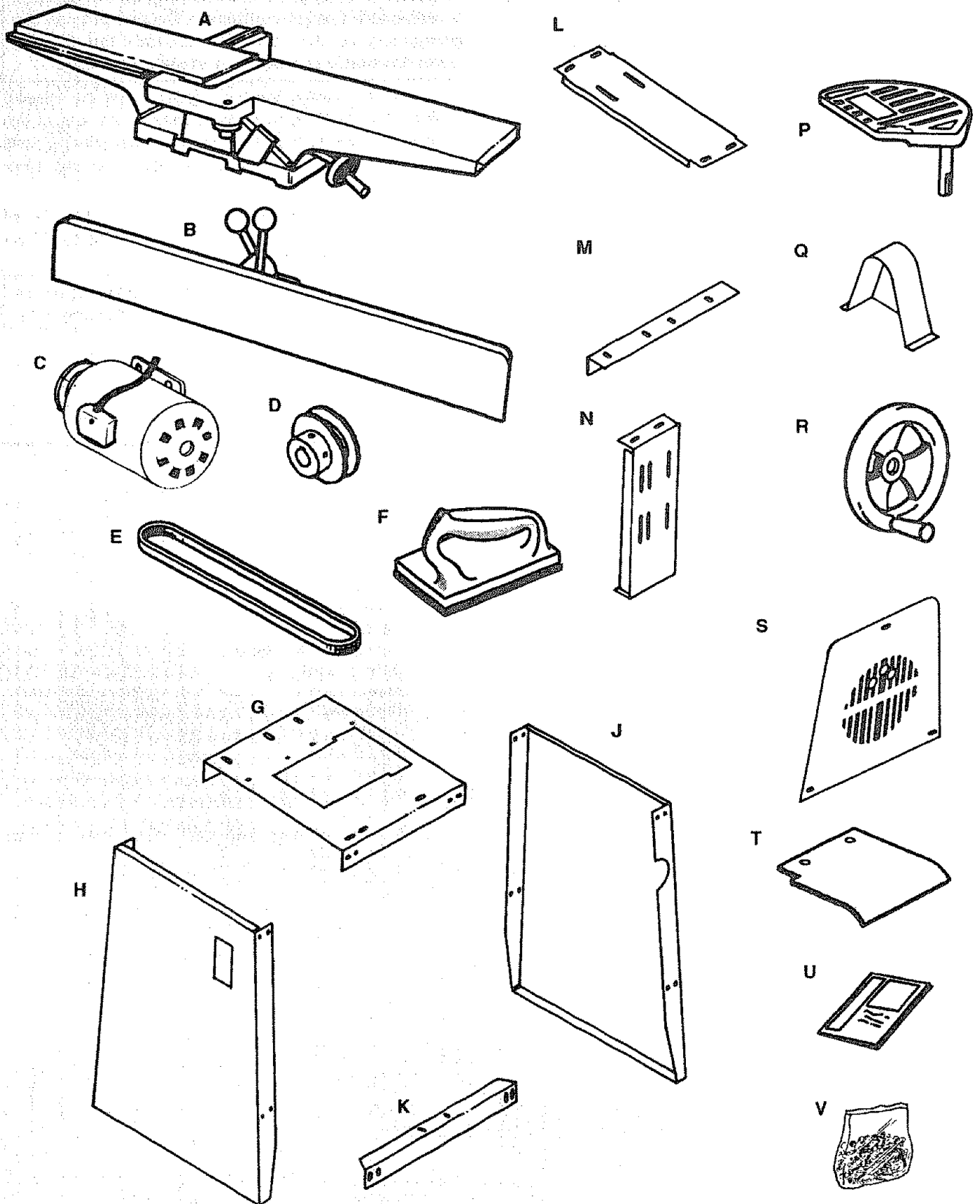

List of Loose Parts (From Bag Assembly)

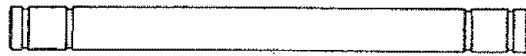

Rod-Knife Gauge

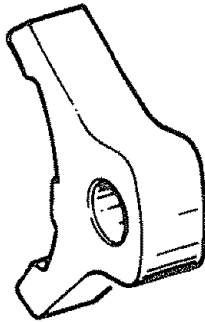

Gauge-Knife (2)

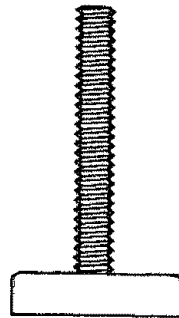

Leveling Feet (4)



3mm Hex-L Wrench

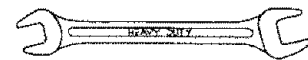

**Wrench 8mm/10mm
Wrench 12mm/14mm**



Switch Key (1)



Retaining Ring (4)



Wire Nut



**External
Lockwasher #8 (2)**



**Washer (8)
1/4"**

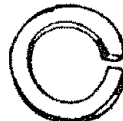

**Lockwasher (3)
3/8"**

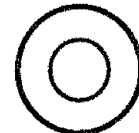

**Washer (34)
13/32"**



**Lockwasher (30)
5/16"**



**Screw Pan Head (2)
8-32 x 5/8**



**Screw Pan Head (8)
1/4-20 x 1/2**

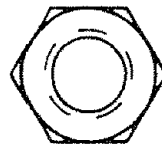

**Hex Jam Nut (8)
3/8-16**



**Nut Hex (30)
5/16-18**



**Hex Head Bolt (3)
3/8-16 x 3/4**



**Carriage Bolt (30)
5/16-18 x 3/4"**

Assembly

WARNING: Although compact, this tool is heavy. To avoid back injury, get help whenever you have to lift the tool.

Assemble The Stand

1. From among the loose parts, find the following:

Description	Qty.
Carriage Bolt 5/16-18 x 3/4.....	16
Washer 13/32	16
Lockwasher 5/16	16
Nut 5/16-18	16
Stand Top Panel.....	1
Stand Front Panel.....	1
Stand Rear Panel	1
Stiffeners	2

2. Place the top panel on the floor upside down. Using the carriage bolts, washers and nuts, attach the front and rear panels as shown. Continue by attaching the two lower brackets to the front and rear panels.

NOTE: Make sure front panel (with switch box hole) is mounted opposite of four tapped holes in panel top.

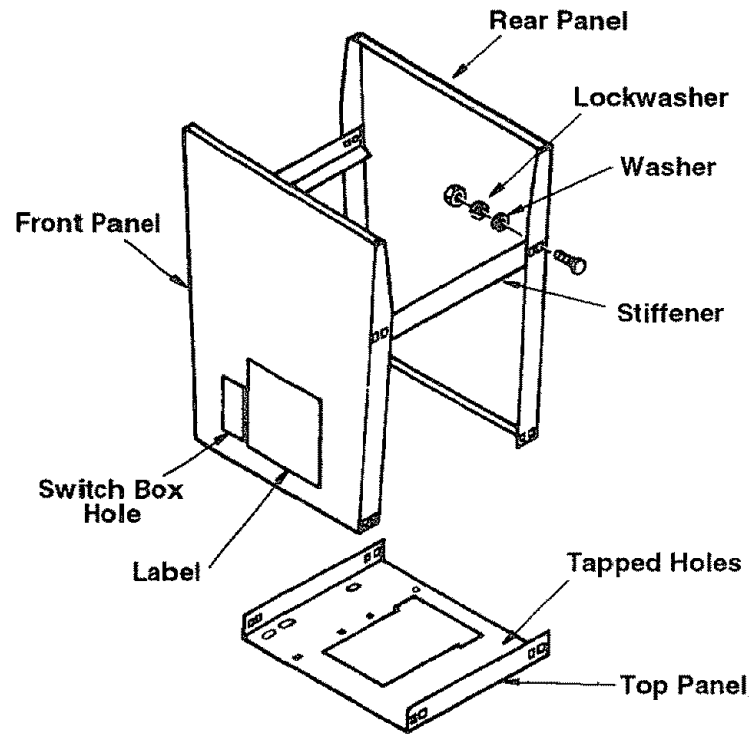
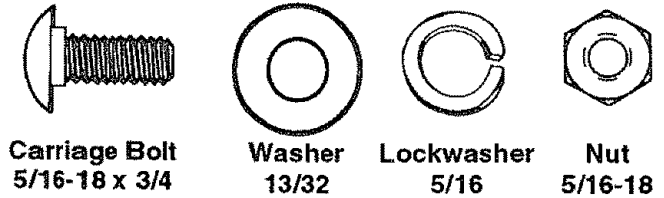

Install the Leveling Feet

From the loose parts bag find four (4) leveling feet, four (4) 3/8 washers and eight (8) 3/8-16 hex nuts. Install leveling feet as shown. Later when the jointer/planer is completely assembled and put in its permanent location in your workshop, you will need to level the leg set.

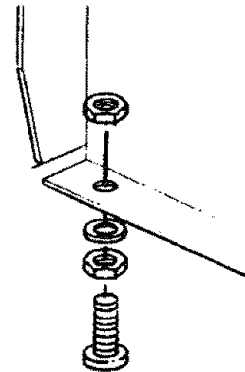

Installing Motor Brackets

1. From among the loose parts, find the following:

Description	Qty.
Carriage Bolt 5/16-18 x 3/4.....	10
Washer 13/32.....	10
Lockwasher 5/16	10
Nut 5/16-18.....	10
Upper Motor Bracket	1
Lower Motor Bracket	1
Vertical Motor Bracket	1

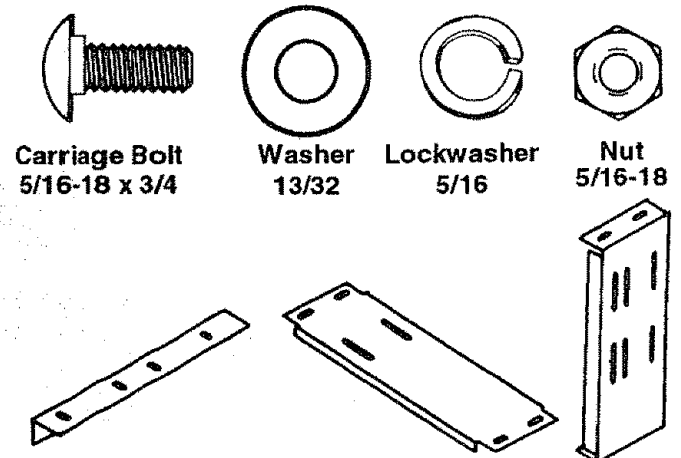

2. Install lower motor brackets as shown using (4) 5/16-18 carriage bolts, (4) 13/32 washers, (4) 5/16 lockwashers and (4) 5/16-18 hex nuts attach lower bracket on top of stiffeners. Hand tighten only.

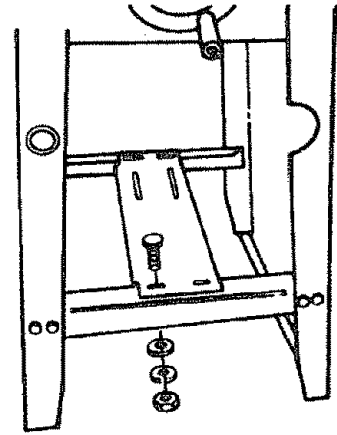

3. Install vertical motor bracket using (2) 5/16-18 carriage bolts, (2) 13/32 washers, (2) 5/16 lockwashers and (2) 5/16-18 hex nuts attach vertical bracket at the bottom only onto slots of lower motor bracket as shown. Hand tighten only.

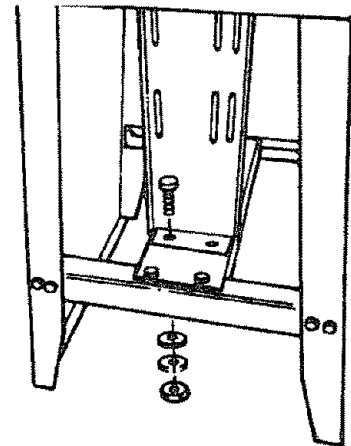

4. Install top stiffener using (4) 5/16-18 carriage bolts, (4) 13/32 washers, (4) 5/16 lockwashers and (4) 5/16-18 nuts. Install top stiffeners under flange of vertical stiffener as shown.

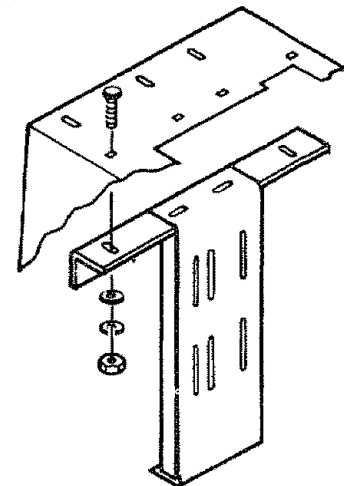

5. Place stand upright and tighten all leg set screws with open end wrench supplied.

Assemble Motor To Stand

1. From among the loose parts, find the following:

Description	Qty.
Carriage Bolt 5/16-18 x 3/4	4
Washer 13/32	4
Lockwasher 5/16	4
Nut 5/16-18	4
Motor	1
Pulley	1

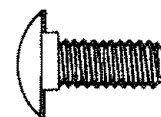

Carriage Bolt
5/16-18 x 3/4



Washer
13/32



Lockwasher
5/16



Nut
5/16-18



Pulley.

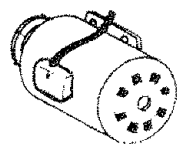

Motor

Assembly (continued)

- Remove tape from motor shaft. Be sure key stays in slot in shaft. Slide the motor pulley onto the motor shaft until pulley hits shoulder on shaft. Tighten the two set screws in the pulley with supplied 3mm Hex "L" wrench.
- With the leg stand on its side, set the motor on the vertical motor bracket, aligning it to the bottom of the slots so it won't slip when the stand is tilted upright. Align motor pulley vertically with slot in top of base. Attach it to the bracket with carriage bolts, washers, lockwashers and nuts. **HAND TIGHTEN ONLY.** The motor position will be adjusted later when the V-belt is installed.
- Slowly set the stand upright.

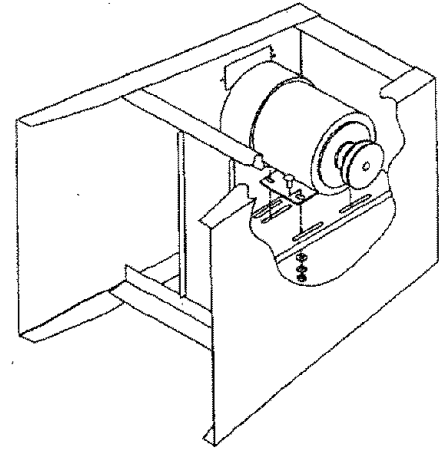

Assemble Switchbox to Stand

- From among the loose parts, find the following:

Description	Qty.
Screw Pan Head 8-32 x 3/8	2
Lockwasher External #8	2
- Attach the switch box to the stand as shown. Make sure that there are lockwashers under the screw heads.
- Route the cord through the bushing provided in the stand.

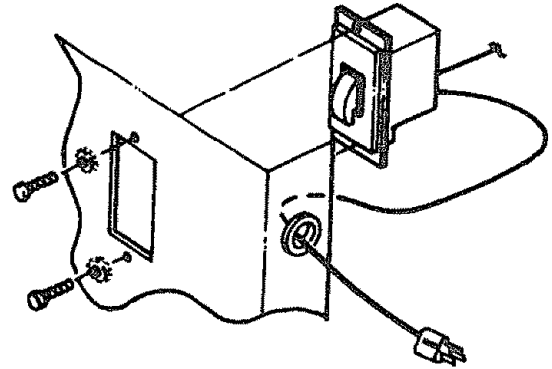

Assemble Bed to Stand

- From among the loose parts, find the following:

Description	Qty.
Hex Head bolt 3/8-16 x 3/4.....	3
Lockwasher 3/8	3
Handwheels.....	2
Screw Pan Head 1/4-20 x 1/2	2
Washer 1/4	2

WARNING: Although compact, this tool is heavy. To avoid back injury, get help whenever you have to lift the tool.

- Set the bed on top of the stand. Carefully line up the 3 threaded holes in the bed with the 3 slots in the stand. Attach the 3 bolts and lockwashers and tighten.
- Slip the V-belt over the bed pulley. Lift the motor up and slip the V-belt around the motor pulley.

Note: Allow the weight of the motor to tension the belt. No additional tension is required. Visually line up the motor pulley with the bed pulley and tighten the motor mounting bolts.
- Slip the handwheel onto the infeed table elevation shaft and install the washer and screw. Repeat for the outfeed table elevation shaft handwheel.

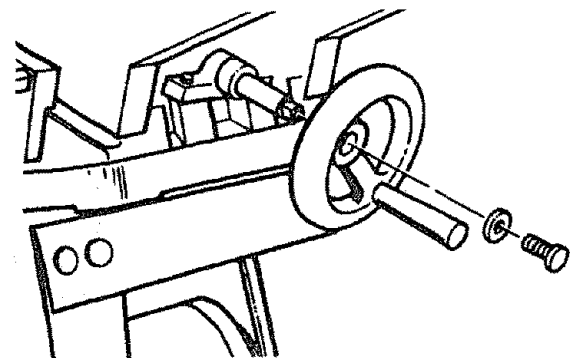
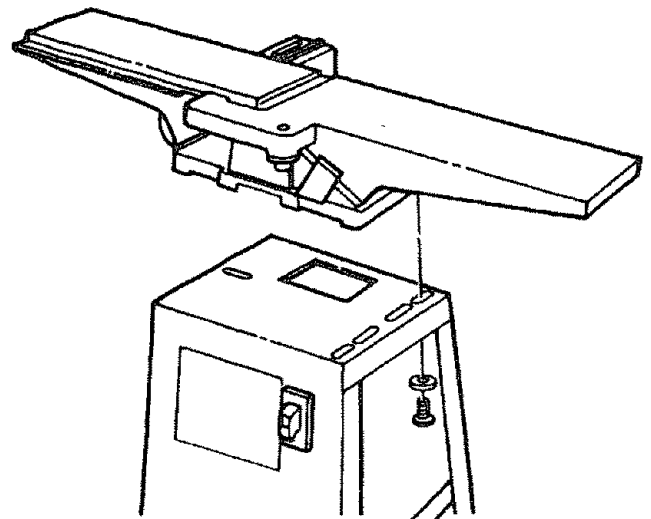

Assemble Fence To Bed

1. Remove the two nuts and the washer from the bolt on underside of the fence assembly.
2. Carefully lift the fence and place it onto the bed, lining up the key slot in the fence with the key in the fence support. The bolt will go through the slot in the fence support.
3. Reinstall the washer and two nuts onto the toggle bolt.
4. Adjust the fence locking mechanism by tightening the upper locking nut until only about 1/4 of a turn of the fence lock knob is possible. Lock the fence in place. Snug the lower nut up to the upper nut with an adjustable wrench. This will lock adjustment in place.

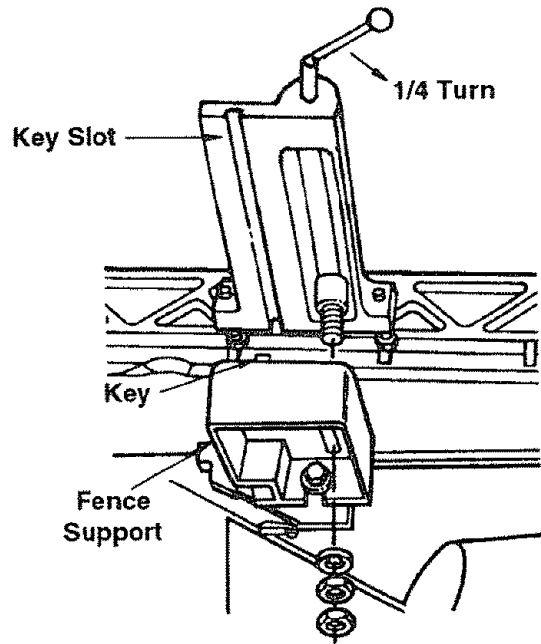

Install Cutter Head Guard

1. Get the cutter head guard. Remove the pan head screw from the bottom of the guard post.
2. Turn the spring-loaded knob 1 turn counterclockwise, looking down through the hole in the infeed table.
3. Line the slot in the guard post with the pin in the knob. Slide the post through table and over pin in the knob.
4. Reinstall the pan head screw in the bottom of the guard post.

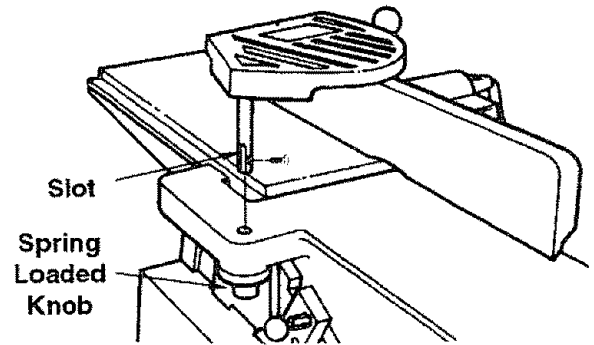

Cutter Head Guard Functional Check

WARNING: Cutter guard helps provide protection over the cutterhead. It must always be in place and functioning properly.

With the power off and the switch key removed, check the guard to make sure it is functioning properly.

- Position the fence to the rear of the bed for maximum width of cut. Do not position fence beyond rear edge of cutter knives.
- Pass a 1/4 inch thick piece of wood over the cutterhead between the guard and the fence.

The guard must return automatically to a "rest position" against the fence when free of the wood.

If guard does not return automatically, adjust the guard spring, as described in the next section.

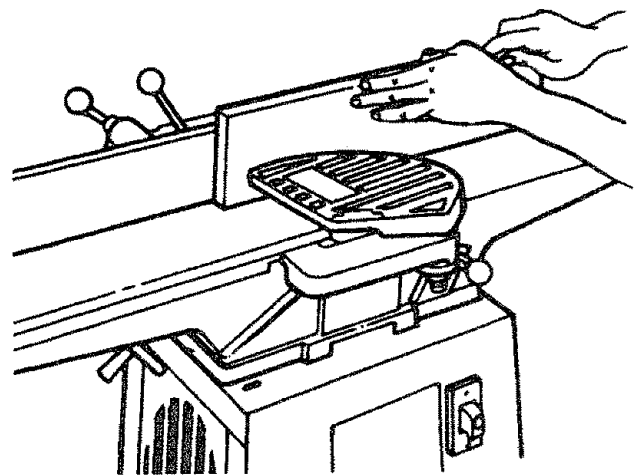

Assembly (continued)

Adjusting Guard Spring

1. Remove the pan head screw from bottom of the guard post.
2. Remove tension on guard by turning tension knob clockwise. Pull up on guard to remove.
3. Add tension to the cutter head guard in 1/2 turn increments by turning the tension knob and reinserting the guard post.
4. Repeat Cutter Head Guard Functional check as previously described.

NOTE: Do not overtighten the spring. Overtightening may cause premature spring or guard breakage. If the guard or spring breaks or malfunctions, do not use the tool. Replace the defective parts before the tool is put back in service.

When the adjustment is complete, reinstall the pan head screw in the bottom of the guard post.

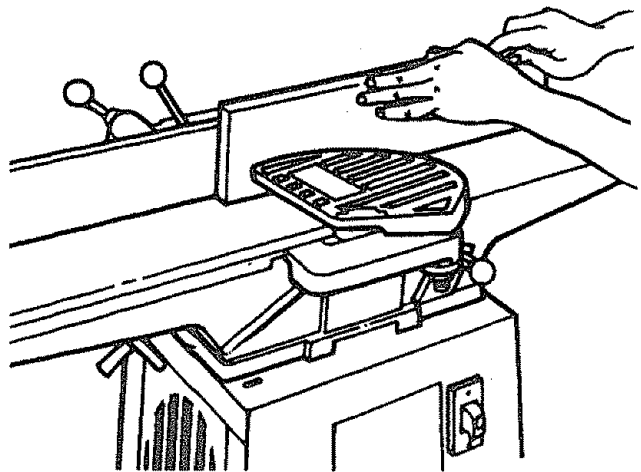

Attaching Pulley Guard

1. From among the loose parts, find the following:

Description	Qty.
Pan Head Screw 1/4-20 x 1/2.....	4
Washer 1/4	4
Pulley Guard.....	1
Cover.....	2

2. Attach the upper pulley guard to the stand with the 4 screws and washers.
3. Install side covers into place with the clips facing toward the outside. Turn the clips to lock in place.

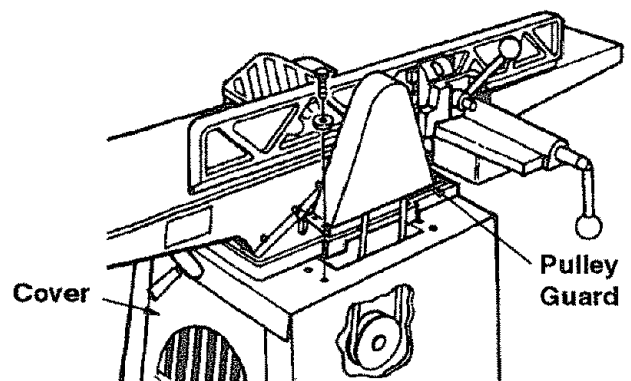

Installing Rear Cutter Head Guard

1. From among the loose parts, find the following:

Description	Qty.
Rear Guard.....	1
Screw Pan Head 1/4-20 x 1/2.....	2
Washer 1/4	2

2. Hold guard in place and fasten to jointer fence assembly with the two screws and lockwashers as shown.

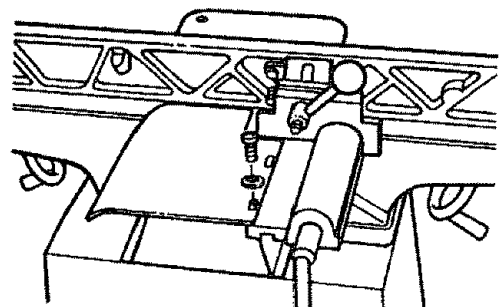

Adjusting the Leveling Feet

Move the jointer/planer to the location where it will reside during use.

Level the legset, loosen top nut and turn bottom nut to raise or lower feet. Using two open wrenches or adjustable wrenches, adjust all four leveling feet if necessary and then tighten the nuts.

NOTE: These levelers are not intended for height adjustment, only leveling adjustment.

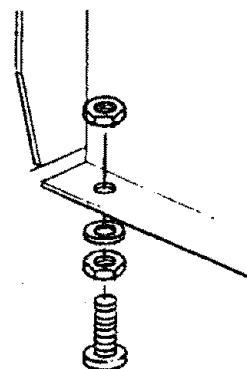

Getting to Know Your Jointer/Planer

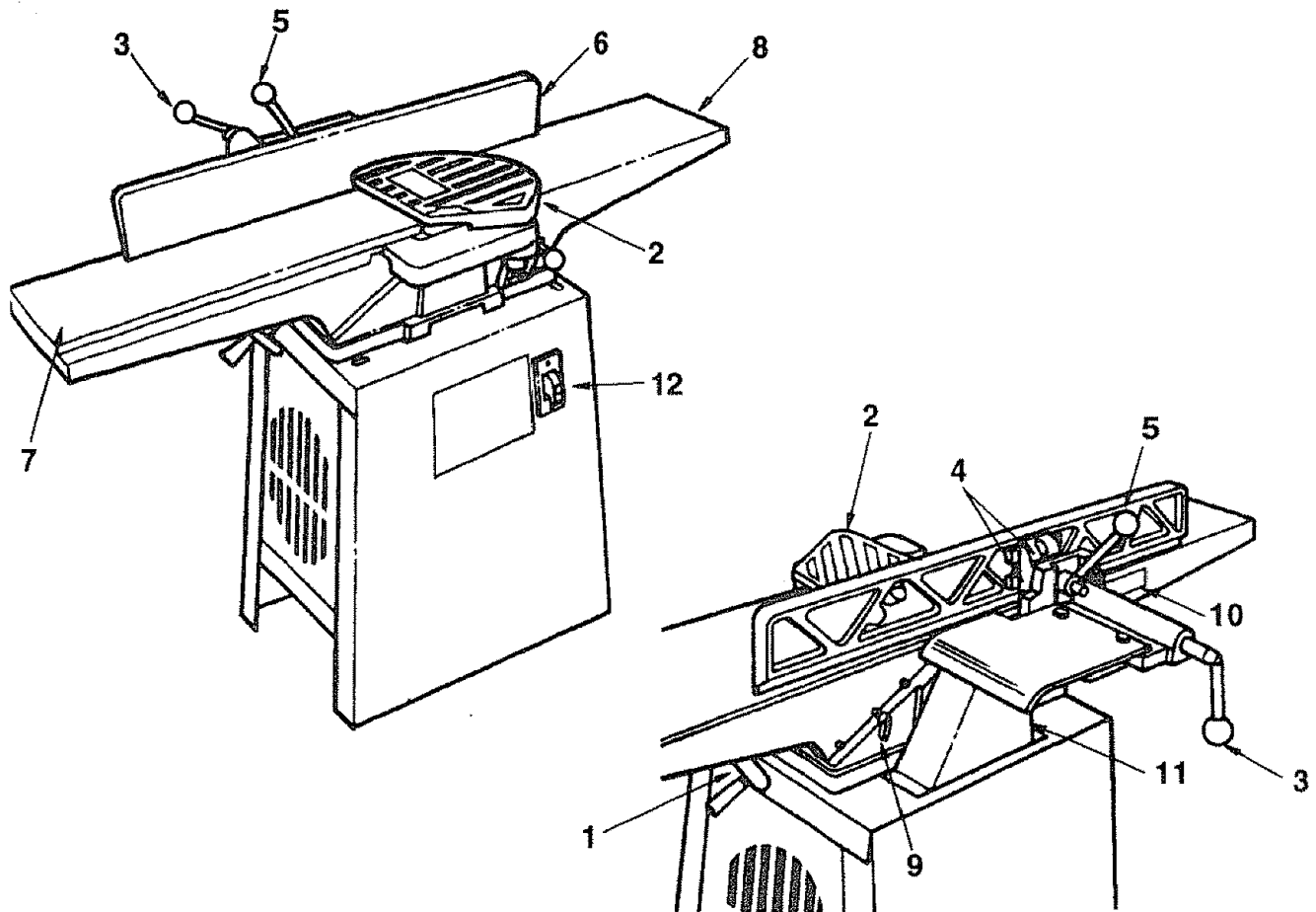

WARNING: For your own safety always lock the switch "OFF" when jointer/planer is not in use. Remove key and keep it in a safe place, also, in the event of a power failure, turn switch off. Lock it and remove the key. This will prevent the jointer/planer from starting up again when the power comes back on.

For your own safety turn switch "OFF" and remove plug from power source outlet before making any adjustments.

WARNING: Read, understand and perform entire "Adjustment" section before turning on the jointer/planer.

1. Depth of Cut Handwheel

By turning the handwheel you can control how much wood will be removed from the workpiece on each cut.

2. Cutter Head Guard:

Helps protect the operator from the sharp knives on the cutterhead. It is spring loaded so it automatically keeps the cutterhead covered before, during, and after a cutting operation. It must always be used.

3. Fence Sliding Knob

Allows fence to move across table front to back. This is done to achieve full width of cut or to use a different

(sharper) part of blade.

4. 90° and 45° Fence Stops

When adjusted properly, these stops provide a method for quickly moving the fence to a 90° or 45° position from the table.

5. Fence Tilt (Bevel) Knob

For convenient, rigid locking of the fence.

6. Fence

Tilts and locks for 90° and angular movements.

7. Outfeed Table

The section of a jointer bed which supports the workpiece after it passes over the cutter.

8. Infeed Table

The section of the jointer bed upon which the workpiece is placed before being pushed into the cutter. Its height is adjustable which allows the operator to select the depth of cut.

9. **Table Lock Screw** - When desired, use these screws to lock infeed or outfeed table at a desired height.

10. Nameplate Model/Serial

11. Belt Guard

Protects user from incidental access to the motor belt and pulleys.

Getting to Know Your Jointer/Planer (continued)

CAUTION: Before turning switch "ON", make sure the blade guard is correctly installed and operating properly.

12. On-Off Switch

Turns the tool on and off. The "yellow button" is a key. When it is inserted in the switch lever, the power may be turned ON and OFF. When it is removed, the power cannot be turned ON.

The on-off switch is shaped to make turning it ON accidentally less likely.

In an emergency, it can be turned OFF by striking it with the palm of the hand.

This feature is intended to help prevent unauthorized and possible hazardous use by children and others.

- Insert key into switch.
- To turn the tool "On", insert finger under the switch lever and pull end of lever out.
- To turn the tool "Off", push the lever in. Never leave the tool unattended until it has come to a complete stop.
- To lock the switch in the "Off" position, hold the switch in with one hand and remove the key with the other hand as shown.

WARNING: For your own safety, always lock the switch "OFF" when machine is not in use. Remove key and keep it in a safe place. Also, in the event of a power failure (all of your lights go out) turn switch off and lock it by removing the key. This will prevent the tool from starting up again when the power comes back on.

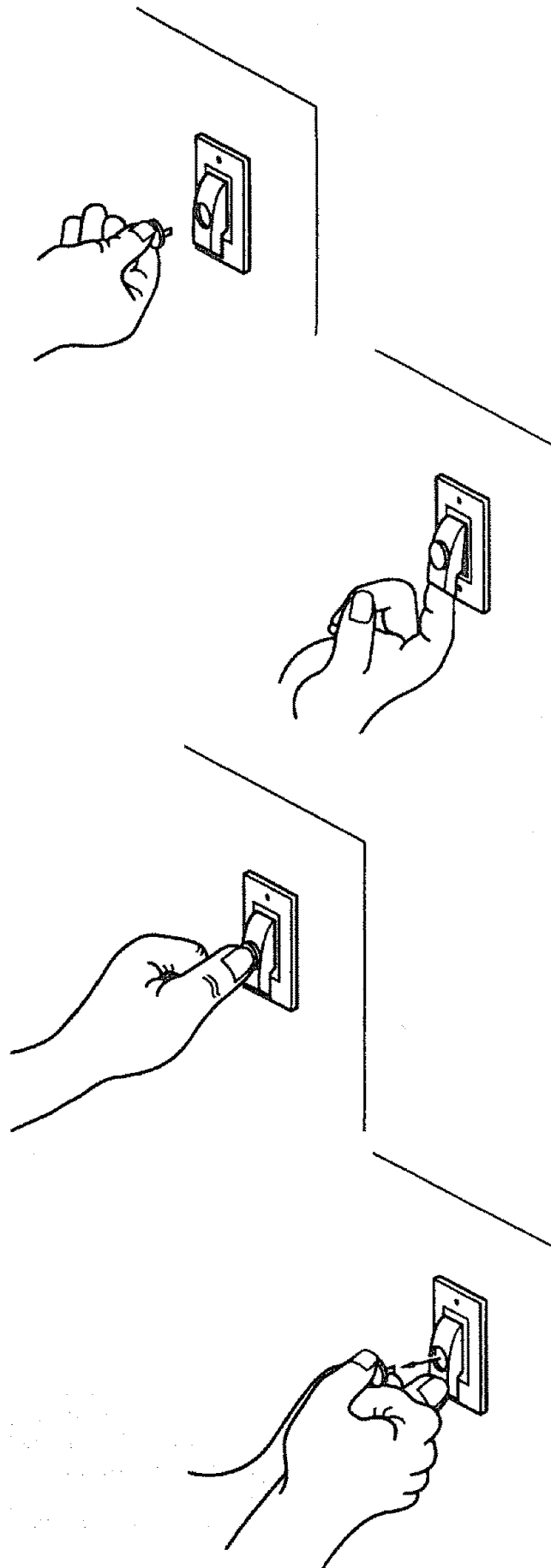

Alignments

Cutter Knife Alignment/Adjustments

WARNING: The cutter knives are extremely sharp. Do not let your hand or fingers touch the cutter knives.

Tools Needed

8mm open end wrench (Supplied).

- Unplug jointer/planer.

WARNING: To avoid injury from accidental start, make sure switch is "OFF" and plug is not connected to power source outlet.

Checking Alignment

Note: The blades are adjusted at the factory, and should not require adjustment.

1. Assemble knife setting gauge.
 - a. From the loose parts find the following:

Description	Qty.
Shaft Knife Adjustment.....	1
Gauge	2
Retaining Ring.....	4

- b. Assemble the two inside retaining rings to the shaft. Slide one of the gauges on the shaft, and assemble the outside retaining ring. Repeat for the other side of gauge.
2. Lower infeed table by turning the depth of cut hand-wheel clockwise.
3. Position the fence to the rear of the jointer, approximately 1/4" beyond the cutter knives. Lock the fence in this position.
4. Remove cutter head guard.
5. Place the gage on the cutter head as shown. The pad of the gauge should be flush with the blade. If not, adjust the blade as follows:

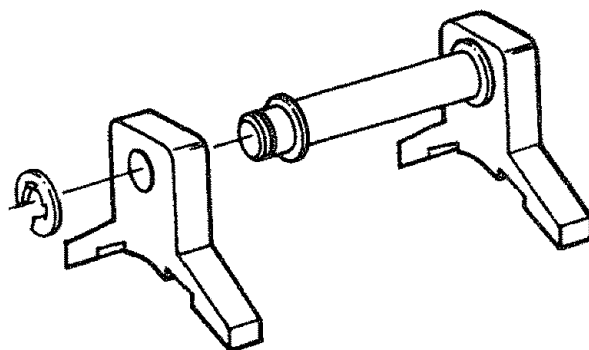

Blade Adjustment

1. Loosen lock screws. The spring under blade will usually force the blade up. Because of rust or resin buildup, the blade may stick. If this happens use a flat blade screwdriver to pry under blade to remove blade. Remove all parts and clean thoroughly with a gum and pitch remover. Reinstall parts as shown, making sure the blade extends 1/16" past the cutter head as shown.
2. Slip gauge assembly into place.
3. Place pads of gauge over blade. Push down on gauge and blade until gauge rests firmly on cutter head.
4. Tighten lock screws.
5. Repeat procedure for other two knives.

Important: Turn the cutter head two full revolutions to make sure the cutter head turns freely and the blades clear the jointer bed.

6. Readjust/reposition outfeed table.

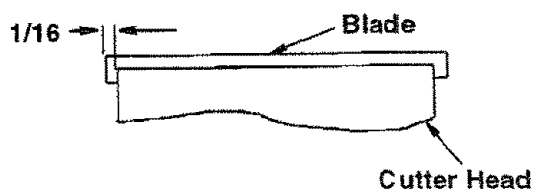
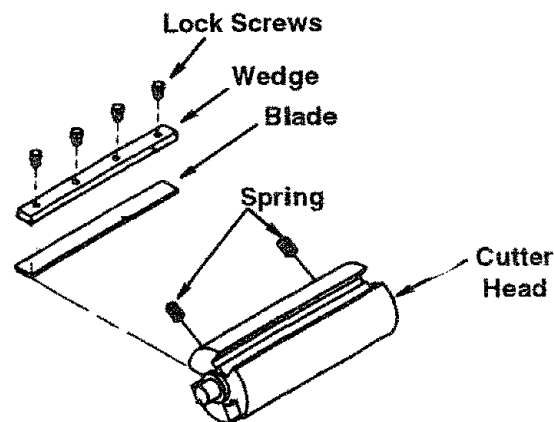
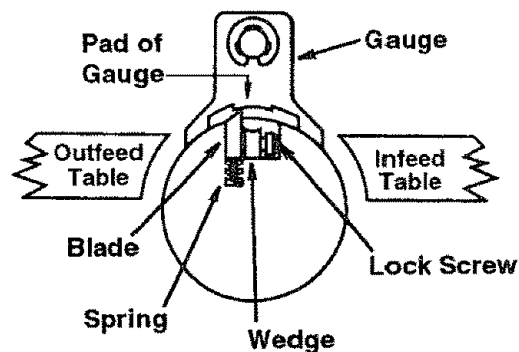

Alignments (continued)

Cutter Knife Sharpening

The knives can be honed individually with an ordinary oilstone.

Make sure your oilstone is not worn in the center. It must be flat.

Be sure to remove the burr on the flat side.

WARNING: The cutter knives are extremely sharp. Do not let your hand or fingers touch the cutter knives.

If the knives are nicked they must be replaced or reground. They can be reground several times until they become 9/16" wide. **Never install unbalanced knives or reground knives less than 9/16" wide.**

Have your knives reground by someone who is competent. Look under "Sharpening Services" in the "Yellow Pages" of your telephone directory.

NOTE: The knives may have a second, very small ground surface very close to the sharpened edge of the blade. Hone only the edge of the blade which will be doing the cutting.

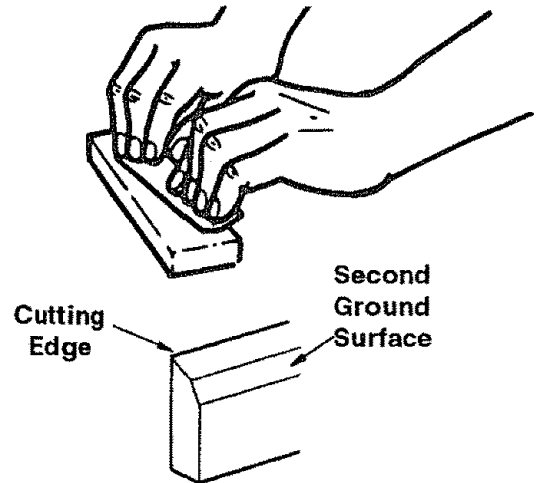
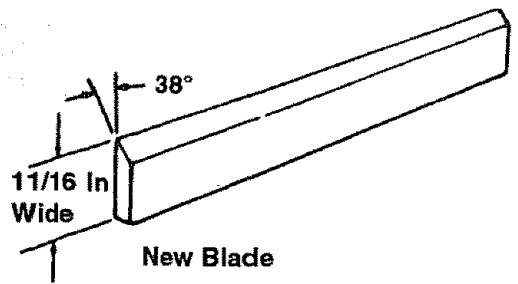

Adjusting Table Extension

The table extension is adjusted at the factory and should not require any additional adjustments. In the event that it shifted during shipping, align it to the outfeed table as follows.

1. Loosen the 2 hex head screws that attach the extension to the outfeed table.
2. Using a straight edge, align the extension to be flush with the outfeed table.
3. Tighten the two screws and recheck the alignment.

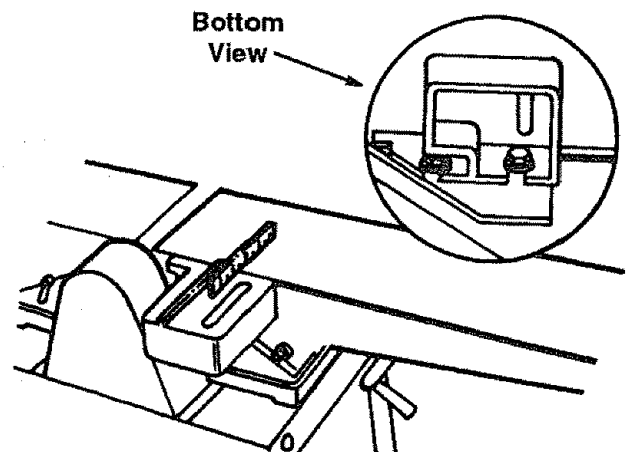

Outfeed Table Adjustment

To check this alignment proceed as follows:

WARNING: To avoid injury from accidental start, make sure switch is "OFF" and plug is not connected to power source outlet.

1. Raise or lower the outfeed table as required, by turning the outfeed table knob, until the outfeed table is exactly level with the knives of the cutterhead at their highest point of revolution.
2. Place a straightedge on the outfeed table, extending over the cutterhead as shown.
3. Rotate the cutterhead by hand. The blades should just touch the straightedge. If a knife is too low or too high at either end, readjust knife per "Cutter Knife Adjustment Replacement" procedure.
4. After the outfeed table has been set at the correct height, lock in place using wing screw table locks. It should not be changed except after sharpening knives.
5. If the outfeed table is too high, finished surface will be curved as shown.

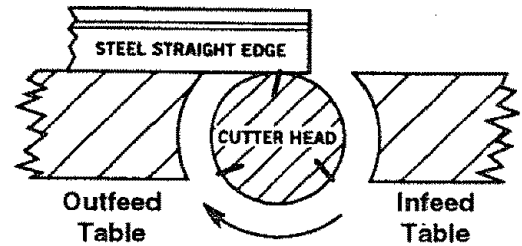

Checking Outfeed Table Alignment

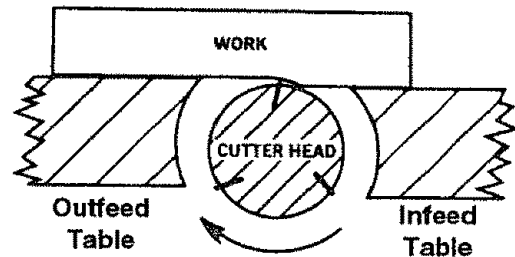

Outfeed Table Too High

Result

6. When the outfeed table is too low, the work will be gouged at the end of the cut.

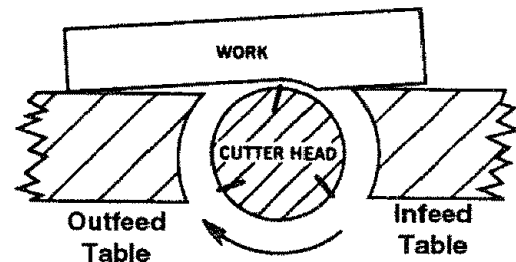

Outfeed Table Too Low

Result

7. As a final check of the outfeed table adjustment, run a piece of wood slowly over the knives for 6 to 8 inches; it should rest firmly on both tables, as shown, with no open space under the finished cut.

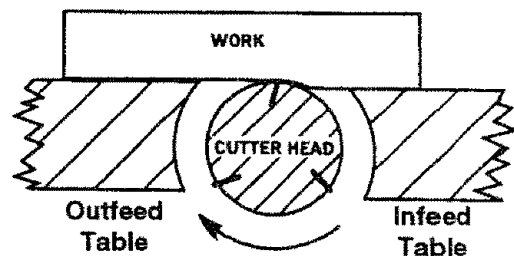

Outfeed Table at Correct Height

Alignments (continued)

Adjusting Table Gibs

"Gibs" are provided to take up all play between the mating dovetail ways of the base and infeed and outfeed tables of your jointer. Proper gib adjustment is necessary for the correct functioning of the jointer. The gibs on your machine were adjusted at the factory and should require no further adjustment. However, to adjust the gibs proceed as follows:

1. Loosen each of the lock nuts. Make sure the table locks are also loose.
2. Finger tighten each set screw in turn, until the screw "bottoms out". Do not overtighten the screws.
3. Recheck table play. If table is still loose, repeat step 2. If table is snug, tighten the set screw lock nuts without allowing set screws to turn.
4. Check that the table raises and lowers freely with the elevation handwheel. If there is too much resistance, loosen the set screws and repeat adjustment.

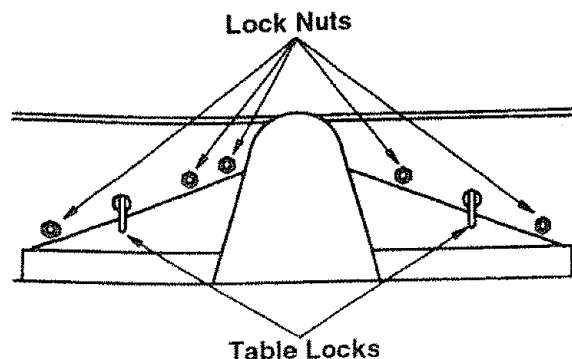

Fence Tilt (Bevel Stop) Alignment

This tool provides fence bevel stops at 90° (fence 90° from bed) and 45°. These stops are set at the factory, but may have fallen out of alignment while in transit. To check for squareness, place an accurate square on outfeed table and check fence while locked at 90° position. **To ensure accuracy and repeatability of the stops, the bottom of the outfeed side of the fence should rest firmly against the outfeed table and against the head of the two stop screws.** Make sure that the infeed table does not interfere with the accuracy of measurement. The infeed table should be lowered to a depth of at least 1/16". Using the stops, check the fence for accuracy. If the fence is not square to the outfeed table, at 90° or 45° perform the following procedure:

NOTE: 90° and 45° stops are adjusted in the same manner. If either fence bevel stop is not square to outfeed table:

WARNING: To avoid injury from accidental start, made sure switch is "OFF" and plug is not connected to power source outlet.

1. Loosen fence tilt knob.
2. Loosen stop screw jam nuts
3. Move stop screws away from the fence.
4. Using a square as shown, square the fence to the outfeed table and lock the tilt knob.
5. Turn the stop screws so they touch the fence. Tighten the jam nuts.
6. Loosen the tilt knob.
7. Move the fence to any angle and then return it to the index. Check for accuracy with square.
8. Readjust the 90° and 45° stops if necessary until the stop maintains an accurate and repeatable fence setting.

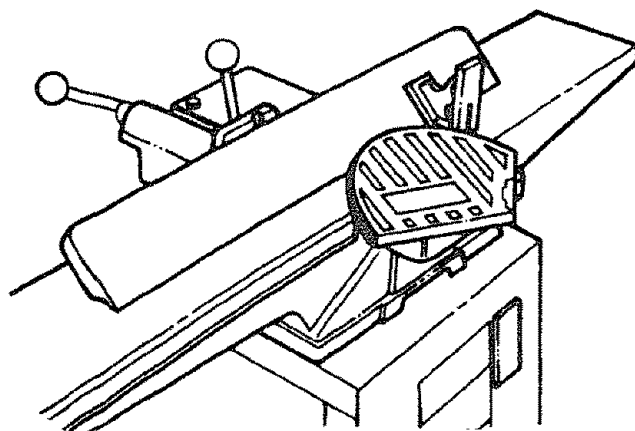
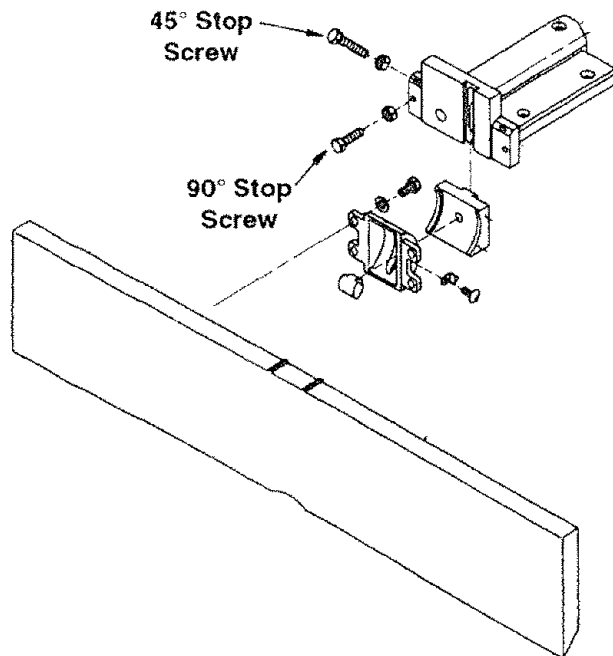

Safety Instructions for Basic Jointer/Planer Operation

Before Each Use:

Inspect your jointer/planer.

WARNING: The 2-1/2 inch jointer/planer pulley and the 3-1/2 inch motor pulley furnished will run the cutter head at about 5000 RPM when used with a 3450 RPM motor. Use of different types of pulleys or motors will change this speed and could cause jamming, binding, kickback, thrown blades or other dangers.

- If any part is missing, bent or broken in any way, or any electrical part does not work properly, turn the jointer/planer off and unplug the jointer/planer.
- Replace damaged or missing parts before using the jointer/planer again.
- Make sure the cutter head turns in the right direction.

The top should move toward the infeed table. Call your Sears Service Department for help if the cutter head turns the wrong way.

- Keep Jointer/Planer interior, free of wood chips and dust buildup around motor and switch box.
- Keep blades sharp. Dull or nicked blades tend to "pound" and chew at the wood, causing kickbacks.
- Make sure the cutter guard works properly. With the switch off and key removed, pull the cutter guard open and let go. If the guard doesn't smoothly swing closed, contact Sears Service.
- To avoid injury from accidental starting, always turn switch off, remove switch key and unplug jointer/planer before installing or removing any blade, accessory or attachment or making any adjustments.

To Avoid Injury From Jams, Slips Or Thrown Pieces (Kickbacks Or Throwbacks):

- Use this jointer/planer to cut only wood.
- Plan your hand placement so your fingers will not be anywhere a sudden slip could cause them to slide or fall into the cutter head. When using only one hold-down/push-block to feed the wood, do not put your other hand on the jointer/planer, workpiece, or hold-down/push-block.
- Make sure the clamps and locks are tight and there is not excessive play in any parts.
- To avoid injury from thrown pieces, make sure the blades are properly installed and the cutter blade wedge screws are tight.
- Adjust the depth of cut to between 1/32 and 1/16 of an inch for best results in most operations. A deep cut makes feeding the wood harder and can cause the wood to kickback. To be sure you will make a depth of cut you planned, always lower the infeed table slightly farther than you wanted. Then, raise the table to the desired depth.

- Use The Right Tool. Don't force tool or attachment to do a job it was not designed for.

Inspect your work area.

- Keep work area clean.
- Cluttered areas and benches invite accidents. Floor must not be slippery from wax or sawdust.
- To avoid burns or other fire damage, never use the jointer/planer near flammable liquids, vapors or gases.
- Before using the jointer/planer, clear the table of all objects not needed to feed the workpiece.
- To avoid injury, don't do layout, assembly, or setup work on the jointer/planer.

Plan your work

- Before trying a new or little used operation, carefully plan your hand placement. Make sure you have proper hold-down/push-blocks, jigs, fixtures, stops, etc. ready to use.
- To avoid injury from unsafe accessories, use only recommended accessories.

Plan Ahead to Protect Your Eyes, Hands, Face and Ears

Dress for safety

- Plan ahead to protect your eyes, hands, face, ears.
- Do not wear loose clothing, gloves, neckties or jewelry (rings, wrist watches). They can get caught and draw you into moving parts.
- Wear nonslip footwear.
- Tie back long hair.
- Roll long sleeves above the elbow.
- Noise levels vary widely. To avoid possible hearing damage, wear ear plugs or muffs when using jointer/planer for hours at a time.
- Any jointer/planer can throw foreign objects into the eyes. This can result in permanent eye damage. Wear safety goggles (not glasses) that comply with ANSI Z87.1 (shown on package). Everyday eyeglasses have

only impact resistant lenses. They are not safety glasses. Safety goggles are available at Sears retail stores. Glasses or goggles not in compliance with ANSI Z87.1 could seriously hurt you when they break.

- For dusty operations, wear a dust mask along with safety goggles.

Inspect your workpiece.

- Make sure there are no nails or foreign objects in the part of the workpiece to be cut.

Plan your cut.

- Small or thin workpieces can kickback when they tip over on the tables or into the cutter head. To avoid head contact or workpiece kickback:
 - Never joint, plane or bevel workpieces shorter than 12 inches.

Safety Instructions for Basic Jointer/Planer Operation (continued)

- When jointing or beveling:
 - Never joint or bevel workpieces less than 3/4 inch wide or 1/4 inch thick.
 - Always use the hold-down/push-blocks when jointing or beveling wood narrower than 3 inches.
 - When rabbeting, always make cuts in 1/8" increments or less.
- When planing:
 - Never plane wood thinner than 1/2 inch.
 - Always use hold-down/push-blocks when planing wood thinner than 3 inches.
 - Never cut **Freehand**. Guide your workpiece solidly against the fence and table top.
 - Make sure there's no debris between the workpiece

- and its supports.
- Use extra caution with large, very small or awkward workpieces.
- Use extra supports (tables, saw horses, blocks, etc.) if your workpiece is hard to hold down to the table. Never use another person as additional support or to help feed, support or pull the workpiece.
- Never cut more than one workpiece at a time.
- Never turn your table jointer/planer "ON" before clearing everything except the workpiece and related support devices off the table.

Avoid Accidental Starting.

- Make sure switch is "OFF" before plugging jointer/planer into a power outlet.

Whenever Jointer/Planer Is Running:

WARNING: Don't allow familiarity (gained from frequent use of your jointer/planer) cause a careless mistake. Always remember that a careless fraction of a second is enough to cause a severe injury.

Keep Children Away.

- Keep all visitors a safe distance from the jointer/planer.
- Make sure bystanders are clear of the jointer/planer and workpiece.
- Before actually cutting with the jointer/planer, let it run for a while. If it makes an unfamiliar noise or vibrates, stop immediately. Turn the jointer/planer off. Unplug the jointer/planer. Do not restart until finding and correcting the problem.

Don't Force Tool.

- Feed the workpiece into the jointer/planer only fast enough to let the tool cut without bogging down or

binding.

Before freeing jammed material.

- Turn switch "OFF".
- Wait for all moving parts to stop.
- Unplug the jointer/planer.
- Check blade, spreader and fence for proper alignment before starting again.

Before Leaving the jointer/planer.

- Turn the jointer/planer off.
- Wait for jointer/planer to come to a complete stop.
- Unplug the jointer/planer.
- Make workshop child-proof. Lock the shop. Disconnect master switches. Remove the yellow switch key. Store it away from children and others not qualified to use the tool.

Basic Jointer/Planer Cutting Operations

Depth of Cut Handwheel Operation

Turning the handwheel counterclockwise will lower the infeed table. This will cause more wood to be removed from the workpiece during the cutting operation.

Turning the handwheel counterclockwise will raise the infeed table causing less wood to be removed from the workpiece.

The maximum amount of wood that can be removed during one cut is 1/8".

Stop Pin Operation

A stop pin is supplied to prevent against planing or jointing more than 1/8" depth of cut. Planing and jointing operations greater than 1/8" per pass are not recommended. Only rabbeting operations should be performed at cutting depths greater than 1/8". Never cut a full 1/2" rabbet in one cut. Cut in 1/8" depth increments until your full depth is acquired.

Feeding the Workpiece

Hold the board firmly down on both tables and against the fence. Keep fingers close together. Feed the board at a continuous even rate of speed until the cut is made along the entire length of the board. Any hesitation or stopping could cause a "step" to be cut on the edge of the board which would cause the board to ride up on the outfeed table resulting in a "crooked" edge on the board.

As the **trailing** hand passes over the cutterhead, remove the **leading** hand. Continue feeding while placing the **leading** hand behind the **trailing** hand. Continue feeding in this manner "hand over hand", until the entire length of the board is cut. As soon as enough of the workpiece has been cut to do so, put **pressure over the cutterhead and outfeed table**.

Do not feed too fast. A slow steady rate of feed produces a smooth accurate cut. Feeding too fast causes a "rippled" cut, makes it difficult to guide the workpiece accurately, and could be dangerous.

NOTE: Wood chips may accumulate inside the jointer/planer. Periodically clean out the chips from the interior of the jointer/planer.

NOTE: Before cleaning wood chips.

- Turn switch "OFF".
- Wait for all moving parts to stop.
- Unplug the jointer/planer.

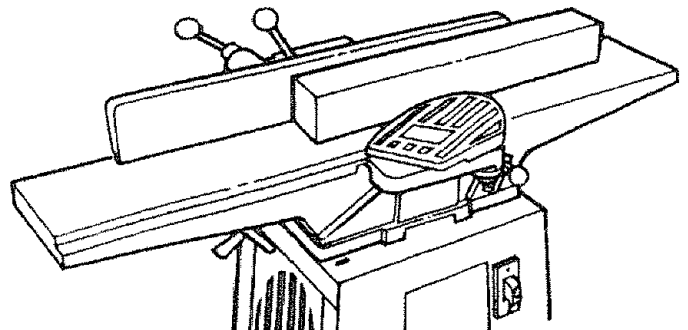
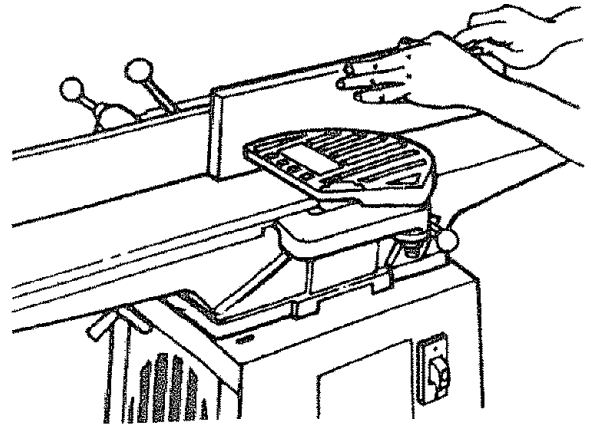

Feed **with the grain** whenever possible. If the nature of the workpiece is such that it must be fed **against the grain**, take very light cuts and feed slowly.



Rotation

With the Grain

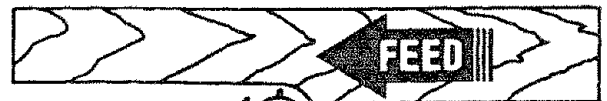



Rotation

Against the Grain

Planing

Planing is removing wood from the widest surface or face of a board so as to make it flat and smooth.

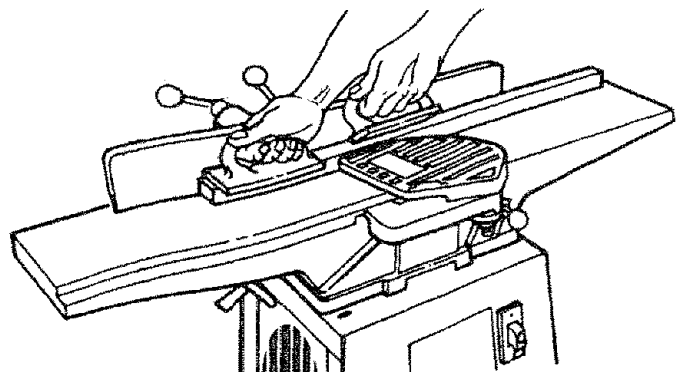
Planing on a jointer will not necessarily make the face that is planed square or parallel to any other surface. Planing on a jointer only smooths and flattens. If you are planing and jointing a board, the planing operation should be performed first. This allows the jointed edge to be cut square to the face which was previously planed flat and smooth.



Basic Jointer/Planer Cutting Operations (continued)

Jointing

Jointing is the removal of wood along the edge of a piece of wood so as to make that edge straight, smooth and square to the wood face which is against the fence.

To ensure a square cut, the workpiece face must be held flat against the fence throughout the entire cut.

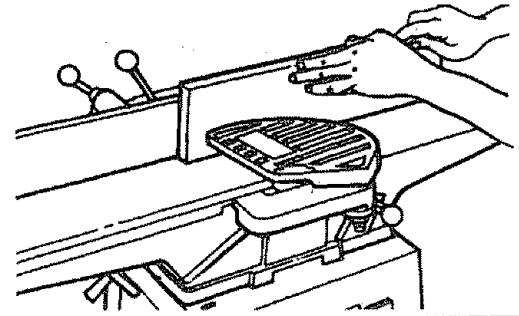

Beveling/Chamfering

Adjust the fence to the desired angle. Lock fence in position using fence tilt knob and fence sliding knob.

For pieces of wood 3 inches or wider hold the board firmly down on both tables and firmly against the fence (as illustrated) with your hands on the side and top of the workpiece. Keep fingers close together.

NOTE: Removing only the corner on the edge of a board is known as **chamfering** while **beveling** is removing the corner or the edge of the board down to the board's surface.

Normally a chamfer is made with one cut and only the corner of the wood is cut off. Therefore, a cut deeper than 1/16 of an inch may be made.

For pieces of wood less than 3 inches wide use hold-down/push-blocks (as illustrated) on the side of the workpiece so you can hold the workpiece in toward the fence at all times as well as down against the table top.

WARNING: Do not contact the cutting knives or the guard with the push-blocks.

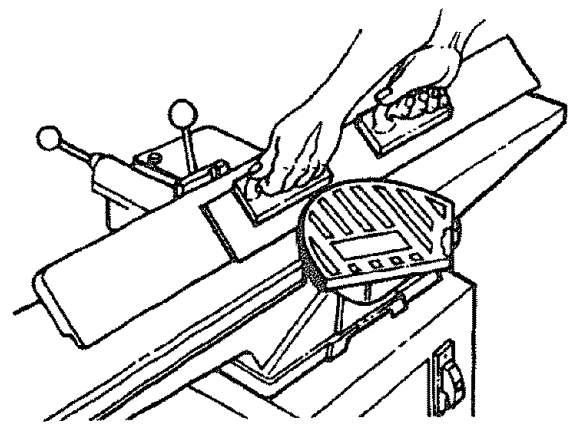
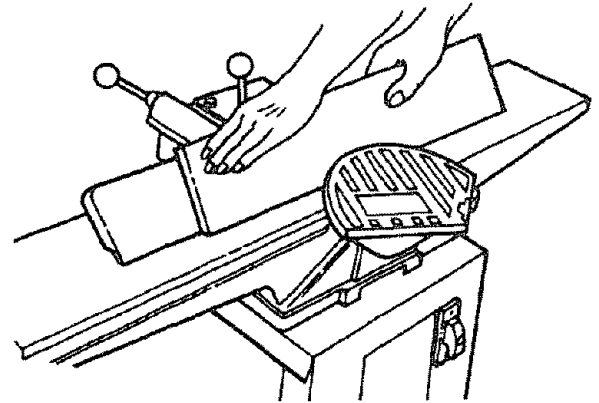

Rabbeting

Rabbeting is very similar to jointing except that only part of the edge is jointed. Do not remove the guard for rabbeting. To rabbet hold the workpiece firmly against the fence. Do not make cuts greater than 1/8". To make a deeper rabbet, make cuts in 1/8" deep increments. Because the workpiece is supported by the outfeed table during a rabbet cut, the infeed table must be lowered after each pass.

Stop Pin Operation

A stop pin is supplied to prevent against planing or jointing more than 1/8" depth of cut. Planing and jointing operations greater than 1/8" per pass are not recommended. Rabbeting operations greater than 1/8" can be performed by pulling the stop pin out and lowering the infeed table in 1/8" increments. The pin automatically resets when you return to the 0" to 1/8" depth of cut range. Never cut a full 1/2" rabbet in one cut. Cut in 1/8" depth increments until your full depth is acquired.

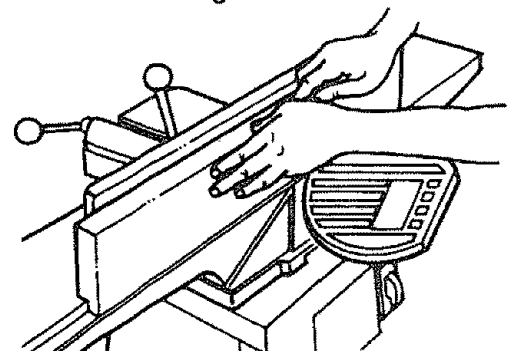
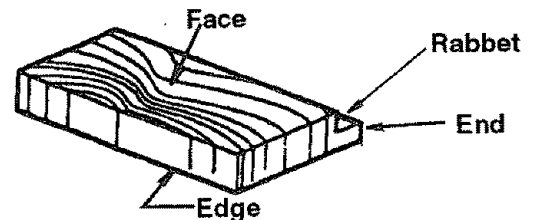

Support Long Workpieces

To avoid injury from slips or kickbacks, use extra supports (tables, saw horses, etc.) at both infeed and outfeed ends if your workpiece is hard to hold down to the table.

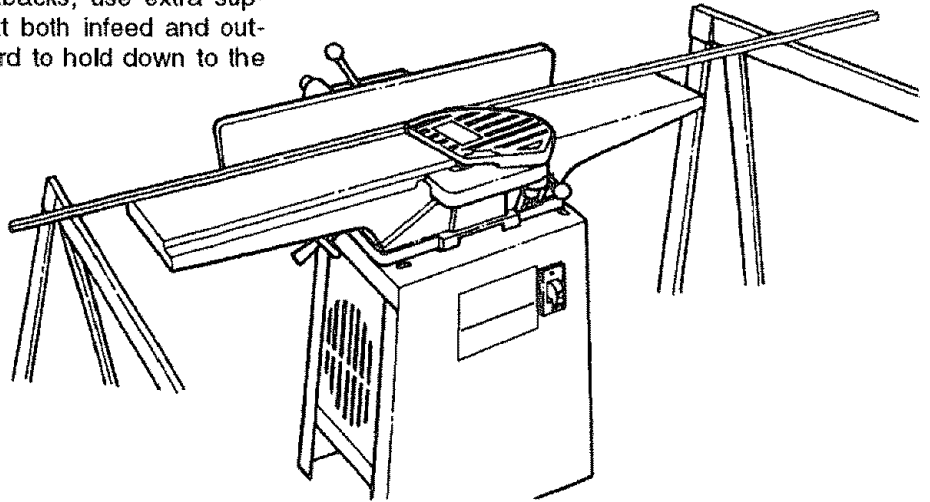

Using the Hold-Down/Push-Blocks

Always use the hold-down/push-blocks when jointing or rabbeting wood that is narrower than 3 inches or planing wood that is thinner than 3 inches (as illustrated).

Grasp the hold-down/push-blocks firmly with the fingers close together and wrapped around the handle. Position the hold-down/push-blocks flat, on top of workpiece and push the workpiece down against the table. This helps to provide a quality cut and minimize the chance of a kick-back.

Hold-down pressure must also be sufficient to prevent hold-down/push-block sliding or slipping on the top face of workpiece when advancing workpiece over cutterhead.

Use a hand-over-hand motion of the hold-down/push-blocks, being careful to maintain control over the workpiece at all times.

This means that once the workpiece has been fed past the cutterhead onto the outfeed table, one hold-down/push-block must always maintain contact of workpiece with outfeed table.

WARNING: If the hold-down/push-blocks tend to slip while feeding, clean rubber surface immediately with sandpaper.

When planing wood between 1/2 inch and 3/4 of an inch thick and narrower than the hold-down/push-block, tilt the hold-down/push-block so that it clears the tip of the cutter guard while feeding.

Never plane wood that is thinner than 1/2 inch. It is apt to split or shatter and thus has a greater tendency to kick-back.

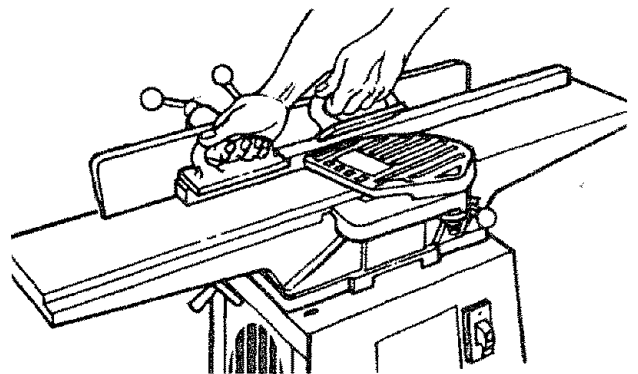
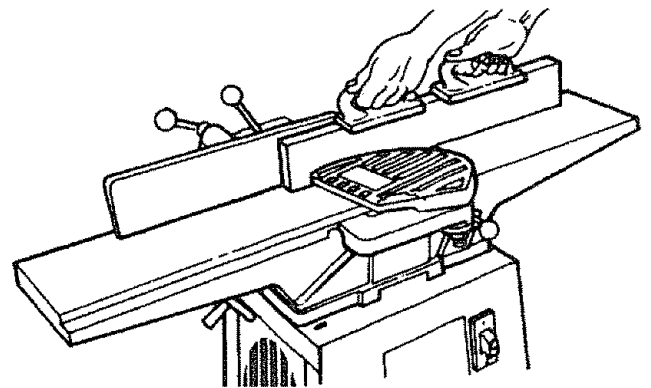

Basic Jointer/Planer Cutting Operations (continued)

Sliding Fence Operation

WARNING: Moving parts can injure. Turn jointer/planer off and wait for all parts to stop, before adjusting fence.

When you are not cutting at full width of cut the fence can be moved across the jointer/planer to take full advantage of the "sharpness" of the blades.

When blades are new or freshly sharpened the fence should be positioned to the extreme rear of outfeed and infeed tables but not beyond the end of the blades.

Most of the cutting (usually jointing) will be done with the fence in this position. As the blades become dull, the fence can be moved toward the guard where the blades are sharper.

To move the fence, turn jointer/planer off, loosen Sliding Fence Knob and slide the fence to the desired position.

SPECIAL NOTE: Make sure table extension is even or above surface of **Outfeed Table**. If it is below the surface see "Assembly" section under "Adjusting Table Extension".

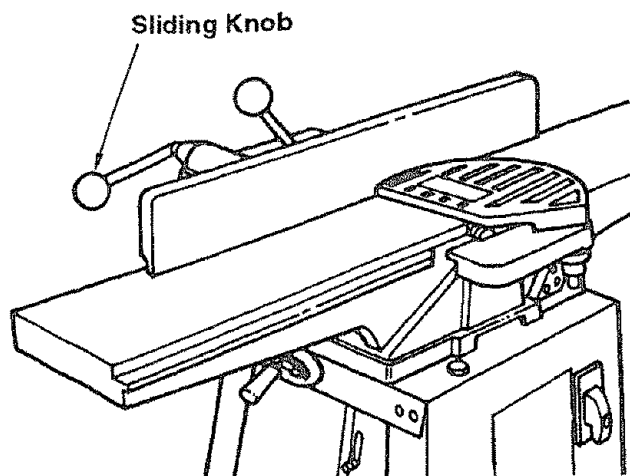

Fence Tilt Operation

- Loosen Tilt Fence Knob.
- Move fence to desired angle.
- Tighten knob.

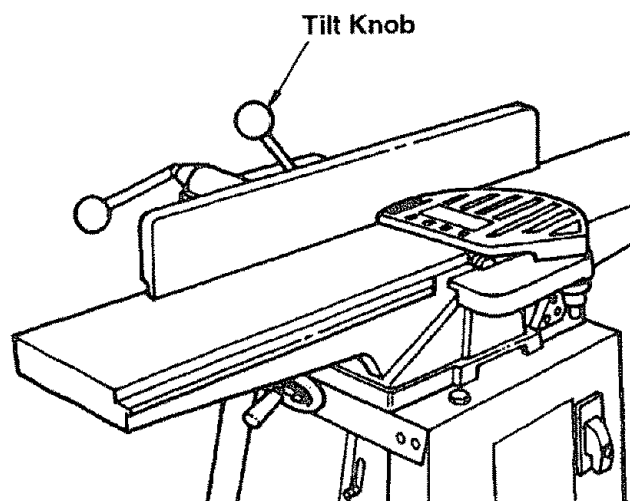

Maintenance and Lubrication

Maintenance

Do not allow pitch to accumulate on the tables, the fence, the cutter guard, the cutterhead or the knives. Clean them with Craftsman Gum and Pitch Remover.

Apply a thin coat of paste type wax to the tables and the fence so that the wood slides easily while feeding. This also deters rusting.

Do not allow chips to accumulate on the underside of the jointer/planer.

If power cord is worn, cut, or damaged in any way, have it replaced immediately.

Disassembly of the motor should only be done by a qualified Sears Technician. Disregarding this may void your tools warranty.

NOTE: The speed of this motor cannot be regulated or changed.

Motors used on woodworking tools are particularly susceptible to the accumulation of sawdust and wood chips and should be blown out or "vacuumed" frequently to prevent interference with normal motor ventilation.

Lubrication

WARNING: Unplug the jointer/planer. Unit could start suddenly. You could be badly hurt.

The ball bearings in this machine are packed with grease at the factory. They required no further lubrication.

The following parts should be oiled occasionally with SAE No. 20 or No. 30 engine oil.

1. Dovetail spacer and dovetail slide.
2. Elevation screw (first clean with gum and pitch remover).

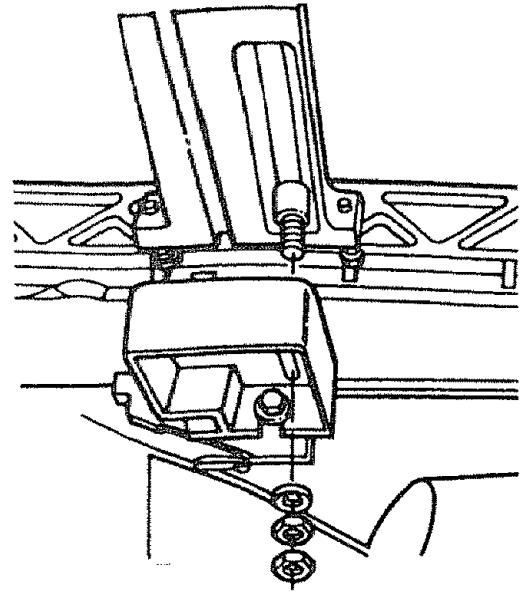

Sears Recommends the Following Accessories

Recommended Accessories

WARNING: To avoid injury from unsafe accessories, use only accessories shown on the recommended accessories list in this manual.

Sears may recommend other accessories not listed in the manual. See your nearest Sears store for other accessories.

Do not use any accessory unless you have received and read complete instructions for its use.

Item	Cat. No.
Cutter Blades	9-2293
Power Tool Know-How Handbook	9-29114 & 29115

Wiring Diagram

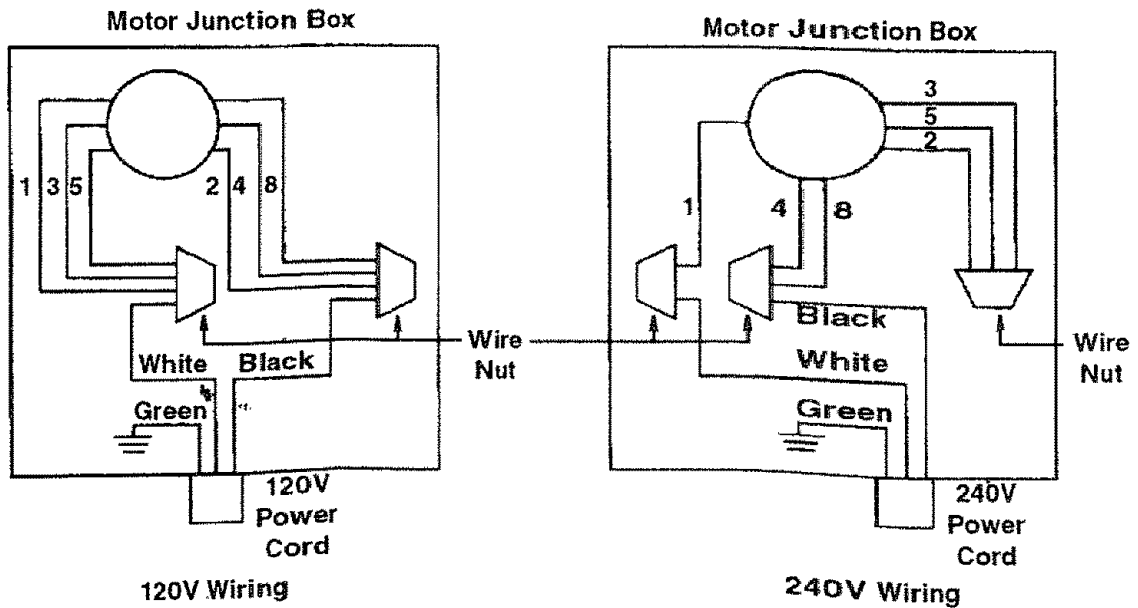

Troubleshooting Guide

WARNING: For your own safety, turn switch "OFF" and remove plug from power source outlet before troubleshooting your jointer/planer

General

Trouble	Probable Cause	Remedy
Motor will not run	<ol style="list-style-type: none"> 1. Defective On-Off switch Defective capacitor Defective motor 2. Low line voltage 3. Belt tension too high 	<ol style="list-style-type: none"> 1. Consult Sears Service. Any attempt to repair this electrical device may create a hazard unless repair is done by a qualified service technician. Repair service is available at your nearest Sears store 2. See Motor Troubleshooting 3. Adjust belt tension
Wood strikes outfeed table after passing over cutterhead	Outfeed table improperly adjusted above cutter blades	Readjust table, see "Adjustment" section
Ripples on planed surface Kickbacks	<ol style="list-style-type: none"> 1. One blade set higher than other 2. Feeding wood too fast 3. Cutting blades are set too high above outfeed table, or they are not leveled with outfeed table 	<ol style="list-style-type: none"> 1. Readjust blades, see "Maintenance" section 2. Feed wood slower 3. Readjust blades, see "Maintenance" section
Planed surface not straight	Outfeed table out of adjustment	Readjust table, see "Adjustment" section
Excessive gouging at end of cut	Outfeed table set too low	Readjust table, see "Adjustment" section
90° and 45° cuts inaccurate	<ol style="list-style-type: none"> 1. Fence stops not adjusted properly 2. Fence bottom not even with outfeed table due to wood chips under fence 	<ol style="list-style-type: none"> 1. Readjust fence stops, see "Getting to Know Your Jointer/Planer" section 2. Clean wood chips from underside of fence
Infeed or outfeed table loose	1. Loose gib	1. Tighten gibs
Cutter guard does not function properly	1. Return spring broken, or spring needs adjustment	<ol style="list-style-type: none"> 1. Consult Sears Service immediately if broken. 2. Adjust spring.

Motor

NOTE: Motors used on wood working tools are particularly susceptible to the accumulation of sawdust and wood chips and should be blown out or "vacuumed" frequently to prevent interference with normal motor ventilation.

Trouble	Probable Cause	Remedy
Excessive noise	<ol style="list-style-type: none"> 1. Motor 2. Pulley set screw is loose. 	<ol style="list-style-type: none"> 1. Have motor checked by qualified service technician. Repair service is available at your nearest Sears Service Center. 2. Tighten set screw.
Motor fails to develop full power. NOTE: Low voltage (Power output of motor decreases in voltage at motor terminals. For example, a reduction of 10% in voltage causes a reduction of 19% in maximum power output of which the motor is capable, and a reduction of 20% in voltage causes a reduction of 36% in maximum power output.)	<ol style="list-style-type: none"> 1. Circuit overloaded with lights, appliances and other motors. 2. Undersize wires or circuit too long. 3. General overloading of power company facilities. 	<ol style="list-style-type: none"> 1. Do not use other appliances or motors on same circuit when using the jointer. 2. Increase wire sizes, or reduce length of wiring. See "Motor Specifications and Electrical Requirements" section. 3. Request a voltage check from the power company.
Motor starts slowly or fails to come to full speed	<ol style="list-style-type: none"> 1. Windings burned out or open. 2. Drive belt tension too high. 3. Defective start capacitor 	<ol style="list-style-type: none"> 1. Have motor repaired or replaced 2. Adjust belt tension 3. Have start capacitor replaced
Motor overheats	<ol style="list-style-type: none"> 1. Motor overloaded 2. Improper cooling (Air circulation restricted through motor due to sawdust accumulating inside of motor.) 	<ol style="list-style-type: none"> 1. Feed work slower into blade. 2. Clean out sawdust to provide normal air circulation through motor. See "Maintenance and Lubrication" section.
Motor stalls (resulting in blown fuses or tripped circuit breakers.)	<ol style="list-style-type: none"> 1. Voltage too low to permit motor to reach operating speed. 2. Fuses or circuit breakers do not have sufficient capacity. 3. Circuit overloaded with lights, appliances and other motors. 	<ol style="list-style-type: none"> 1. Request voltage check from the power company 2. Install proper size fuses or circuit breakers. See "Electrical Connection" section 3. Do not use other appliances or motors on same circuit when using the jointer.
Frequent opening of fuses or circuit breakers	<ol style="list-style-type: none"> 1. Motor overloaded 2. Fuses or circuit breakers do not have sufficient capacity. 3. Circuit overloaded with lights, appliances and other motors. 	<ol style="list-style-type: none"> 1. Feed work slower 2. Install proper size fuses or circuit breakers. See "Electrical Connection" section 3. Do not use other appliances or motors on same circuit when using the jointer.

Repair Parts

Parts List for Craftsman 6-1/8" Jointer/Planer Model No. 113.232240

Figure 1

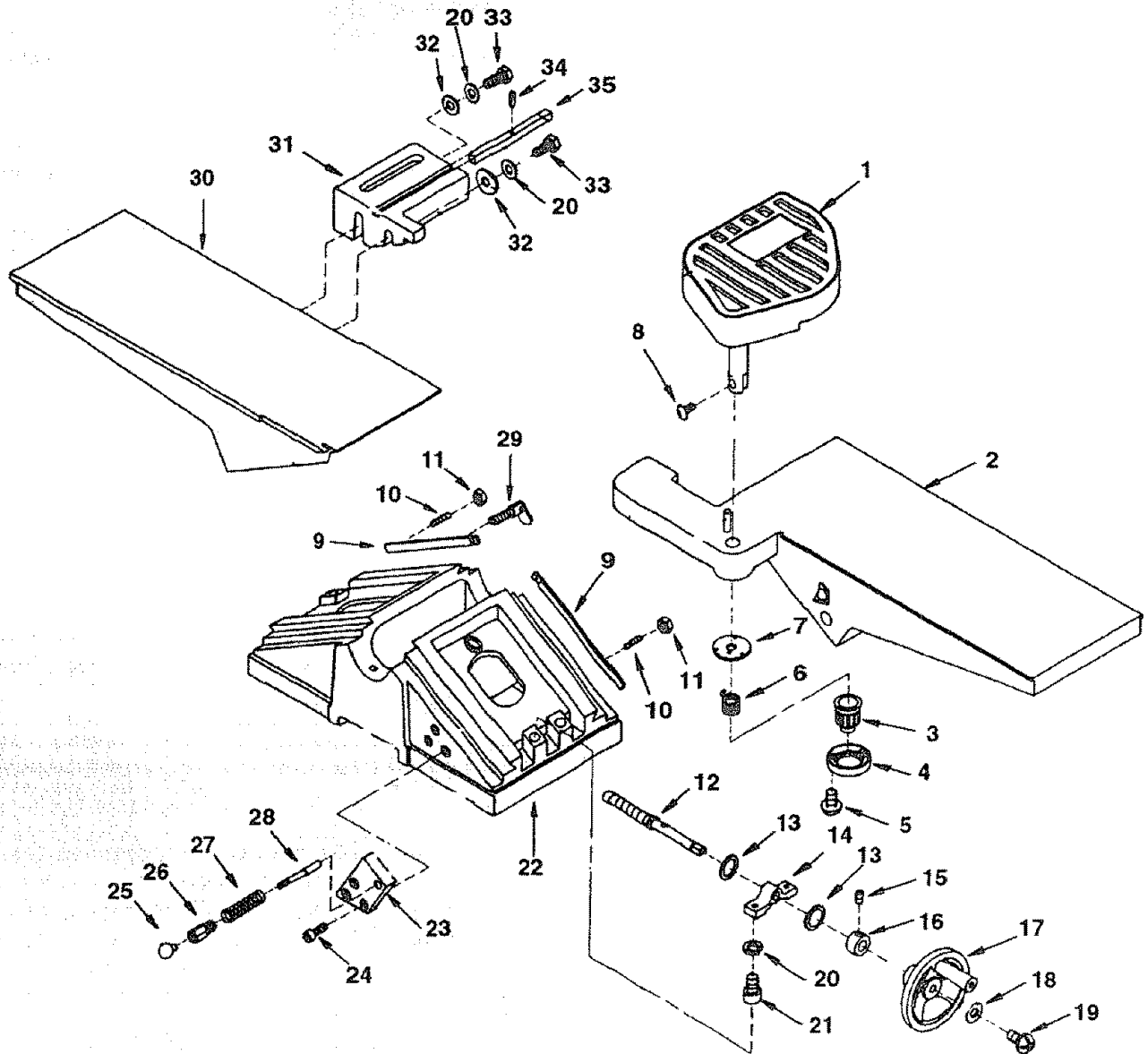

Repair Parts

Parts List for Craftsman 6-1/8" Jointer/Planer Model No. 113.232240

Figure 1

Always order by Part Number - Not by Key Number

Key No.	Part No.	Description
1	824919	Guard Cutter
2	824854	Table Infeed
3	824867	Knob
4	824866	Retainer Knob
5	822495-1	* Screw Pan Hd 5/32 x 5/8
6	824868	Spring
7	824865	Retainer
8	816755-1	Screw Pan Hd M5 x 0.8-10
9	824856	Gib
10	160033-4	Screw Set 1/4-20 x 1
11	STD541025	* Nut Hex 1/4-20
12	824859	Screw Elevation
13	824860	Washer Brass
14	824858	Clamp
15	STD502503	* Screw Set 1/4-20 x 3/8
16	824861	Collar
17	824918	Handwheel
18	STD551025	* Washer 17/64 x 5/8 x 1/32

Key No.	Part No.	Description
19	STD512505	* Screw Pan Hd 1/4-20 x 1/2
20	STD852008	* Lockwasher 8mm
21	141594-13	Screw Cap 5/16-18 x 1-1/4
22	824853	Base
23	824871	Block Stop Pin
24	9421622	Screw Cap 5/16-18 x 3/4
25	824875	Knob Plunger
26	824873	Housing Plunger
27	824872	Spring
28	824874	Plunger
29	824857	Screw Wing 1/4-20 x 1
30	824855	Table Outfeed
31	824862	Holder
32	824863	Washer 3/8 x 20mm x 3mm
33	STD523712	* Screw Hex Hd 3/8-16 x 1-1/4
34	813249-106	Pin Roll 4mm x 20mm
35	824864	Key
—	SP5971	Owners Manual (Not Ills.)

* Standard hardware item, may be purchased locally

Repair Parts

Parts List for Craftsman 6-1/8" Jointer/Planer Model No. 113.232240

Figure 2

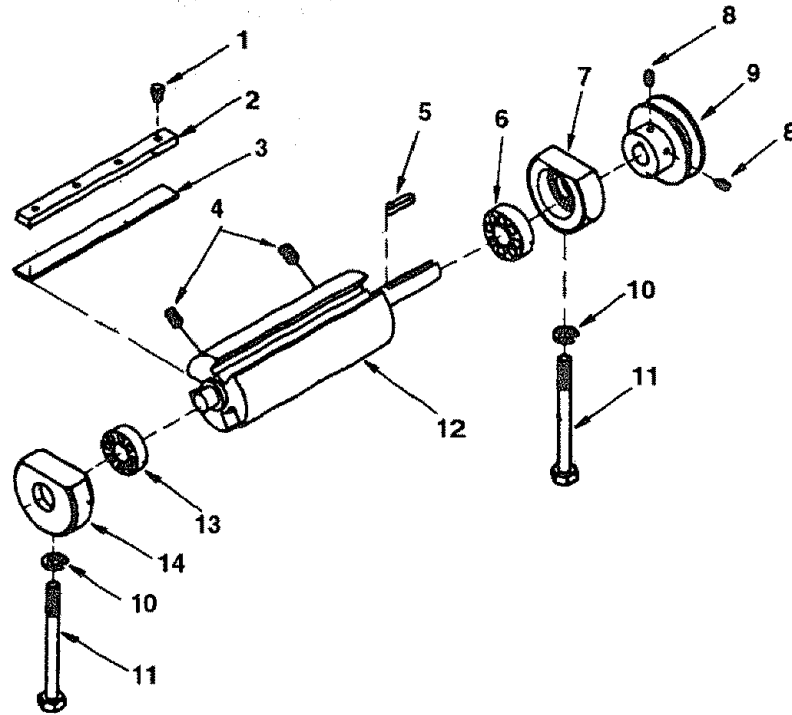

Key No.	Part No.	Description
1	824886	Screw 1/4-28 x 7mm
2	824885	Wedge
3	9-2293	† Blade
4	824883	Spring
5	818654-7	Key
6	820722-6	Bearing
7	824881	Support Bearing

Key No.	Part No.	Description
8	STD502503	* Soc Set Screw 1/4-20 x 3/8
9	824888	Pulley
10	STD852010	* Lockwasher M10
11	824890	Screw Hex 3/8-24 x 3-1/2
12	824880	Cutter head
13	820722-5	Bearing
14	824879	Support Bearing

Repair Parts

Parts List for Craftsman 6-1/8" Jointer/Planer Model No. 113.232240

Figure 3

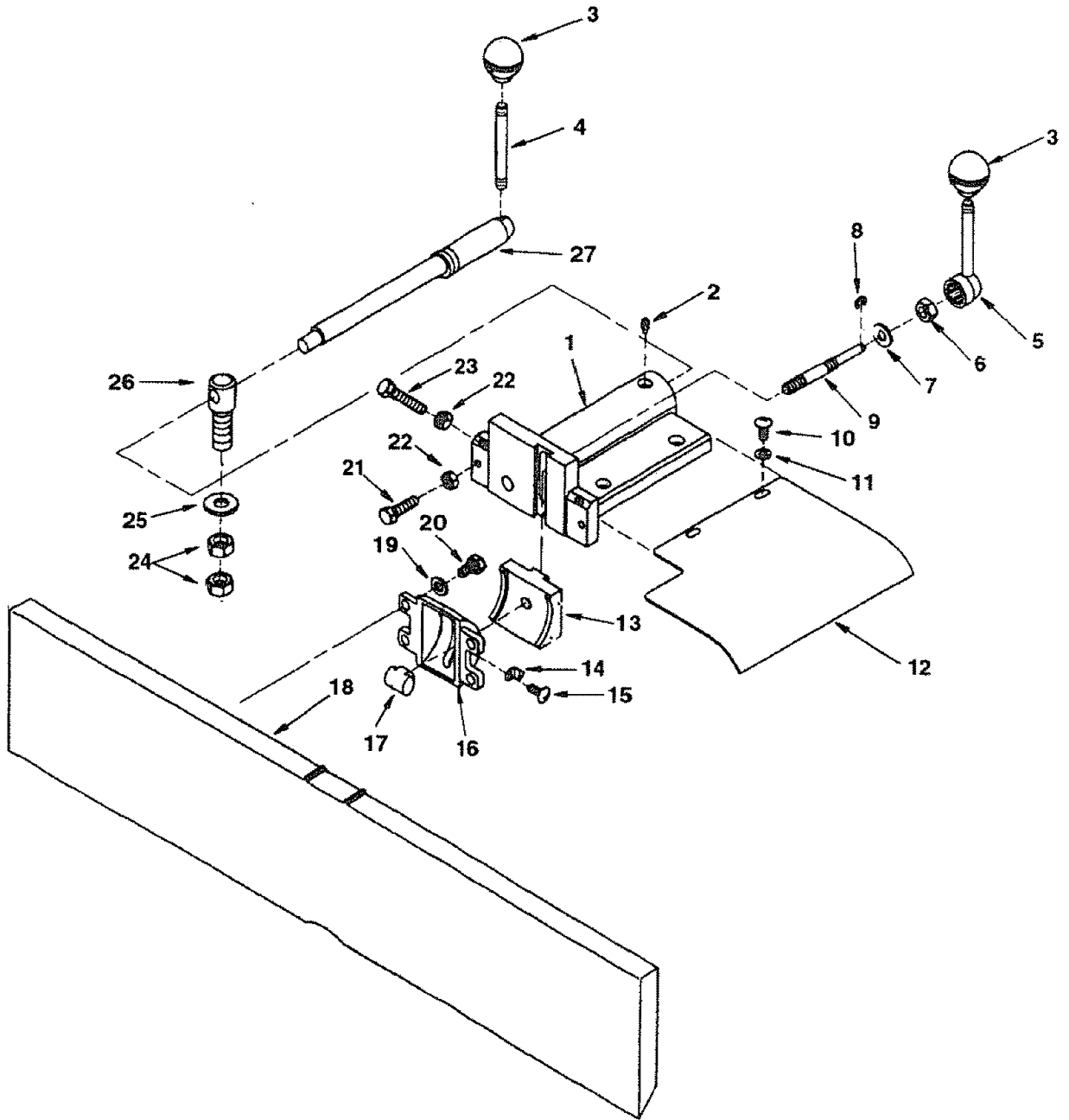

Repair Parts

Parts List for Craftsman 6-1/8" Jointer/Planer Model No. 113.232240 Figure 3

Always order by Part Number - Not by Key Number

Key No.	Part No.	Description
1	824895	Slide Fence
2	102817	Screw Set Dog Point 1/4-20 x 1/2
3	824900	Knob
4	824899	Rod Knob
5	824896	Knob, Nut
6	STD541037	* Nut Hex 3/8-16
7	STD551037	* Washer 3/8 x 3/4 x 3/32
8	820632-3	Ring Retaining 6mm
9	824894	Rod Bevel Lock
10	STD512505	* Screw Pan Hd 1/4-20 x 1/2
11	STD551025	* Washer 17/64 5/8 x 1/32
12	824921	Guard Rear
13	824889	Bracket Trunnion
14	824887	Pointer

Key No.	Part No.	Description
15	824082	Screw Pan Hd 3/16-24 x 1/4
16	824884	Trunnion
17	824893	Nut Bevel Lock
18	824882	Fence
19	STD551031	* Washer 5/16
20	STD523106	* Screw Hex Hd 5/16-18 x 5/8
21	STD523110	* Screw Hex Hd 5/16-18 x 1
22	STD541031	* Nut Hex 5/16-18
23	STD523117	* Screw Hex 5/16-18 x1-3/4
24	STD541150	* Nut Hex 1/2-20
25	STD551050	* Washer 1/2 x 1-1/8 x 3/32
26	824898	Bolt Clamp
27	824897	Shaft Lock

* Standard hardware item, may be purchased locally

Repair Parts

Parts List for Craftsman 6-1/8" Jointer/Planer Model No. 113.232240

Figure 4

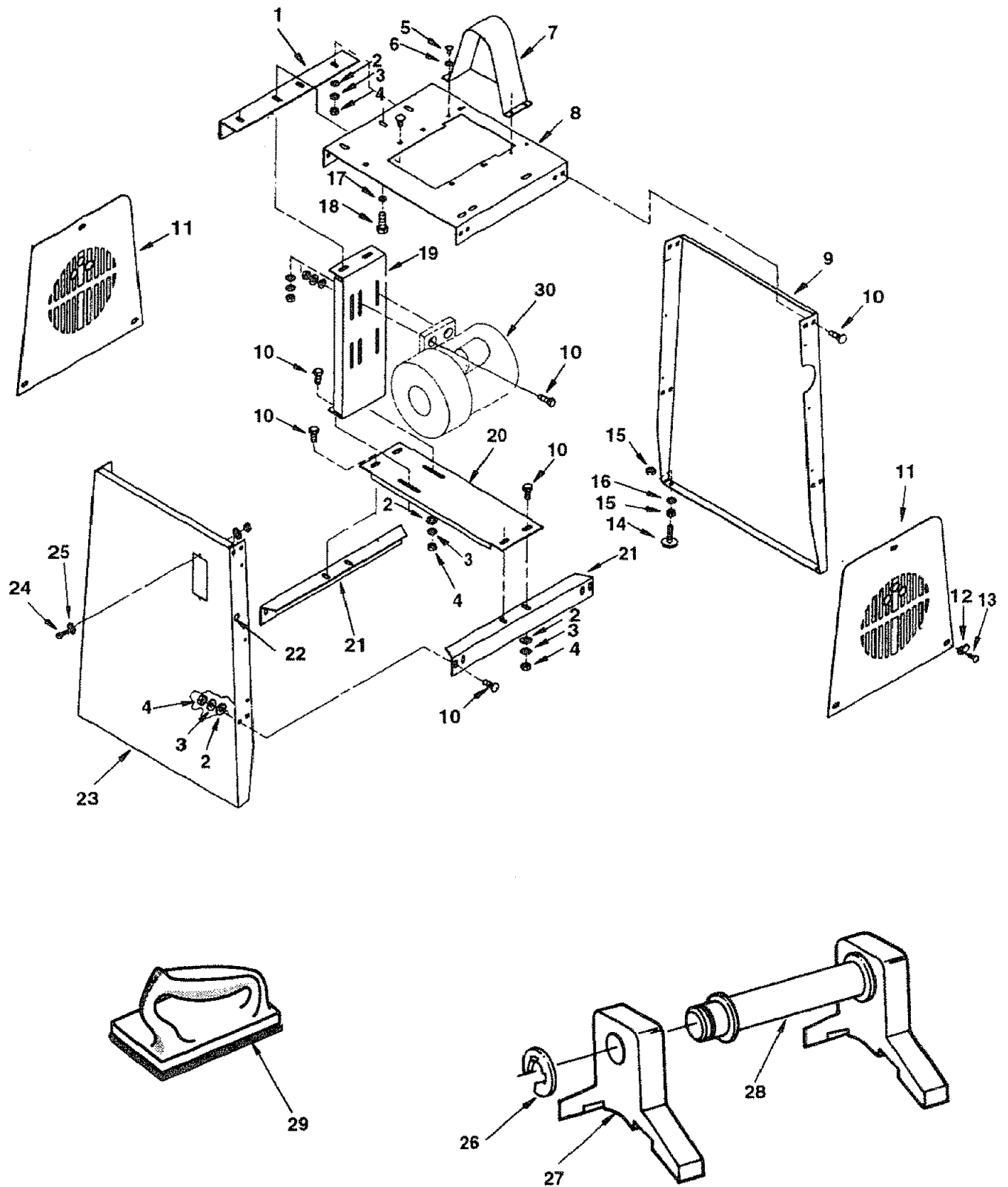

Repair Parts

Parts List for Craftsman 6-1/8" Jointer/Planer Model No. 113.232240 Figure 4

Always order by Part Number - Not by Key Number

Key No.	Part No.	Description
1	824905	Bracket Upper
2	STD551031	* Washer 21/64 x 47/64 x 1/16
3	STD852008	* Lockwasher 8mm
4	STD541031	* Nut Hex 5/16-18
5	STD512505	* Screw Pan Hd 1/4-20 x 1/2
6	STD551025	* Washer 17/64 x 5/8 x 1/32
7	824920	Guard Pulley
8	824901	Panel Top
9	824842	Panel Rear
10	STD533107	* Bolt Carriage 5/16-18 x 3/4
11	824906	Panel Side
12	824930	Clip
13	STD600605	* Screw Pan Hd Ty "T" 6-32 x 1/2
14	803835-1	Foot Leveling
15	STD541037	Nut Hex 3/8

Key No.	Part No.	Description
16	STD551037	* Washer 3/8 x 3/4 x 3/32
17	STD852010	* Lockwasher 10mm
18	STD523707	* Screw Hex 3/8-16 x 3/4
19	824904	Bracket Motor
20	824903	Bracket Lower
21	824902	Stiffener
22	824909	Grommet
23	824841	Panel Front
24	STD510803	* Screw Pan Hd #8-32 x 3/8
25	STD551208	* Lockwasher #8
26	820632-2	Ring Retaining
27	824925	Gauge Knife
28	824926	Rod Knife Gauge
29	67062	Push Block
30	See Fig. 5	Motor Asm

* Standard hardware item, may be purchased locally

Repair Parts

Parts List for Craftsman 6-1/8" Jointer/Planer Model No. 113.232240 Figure 5

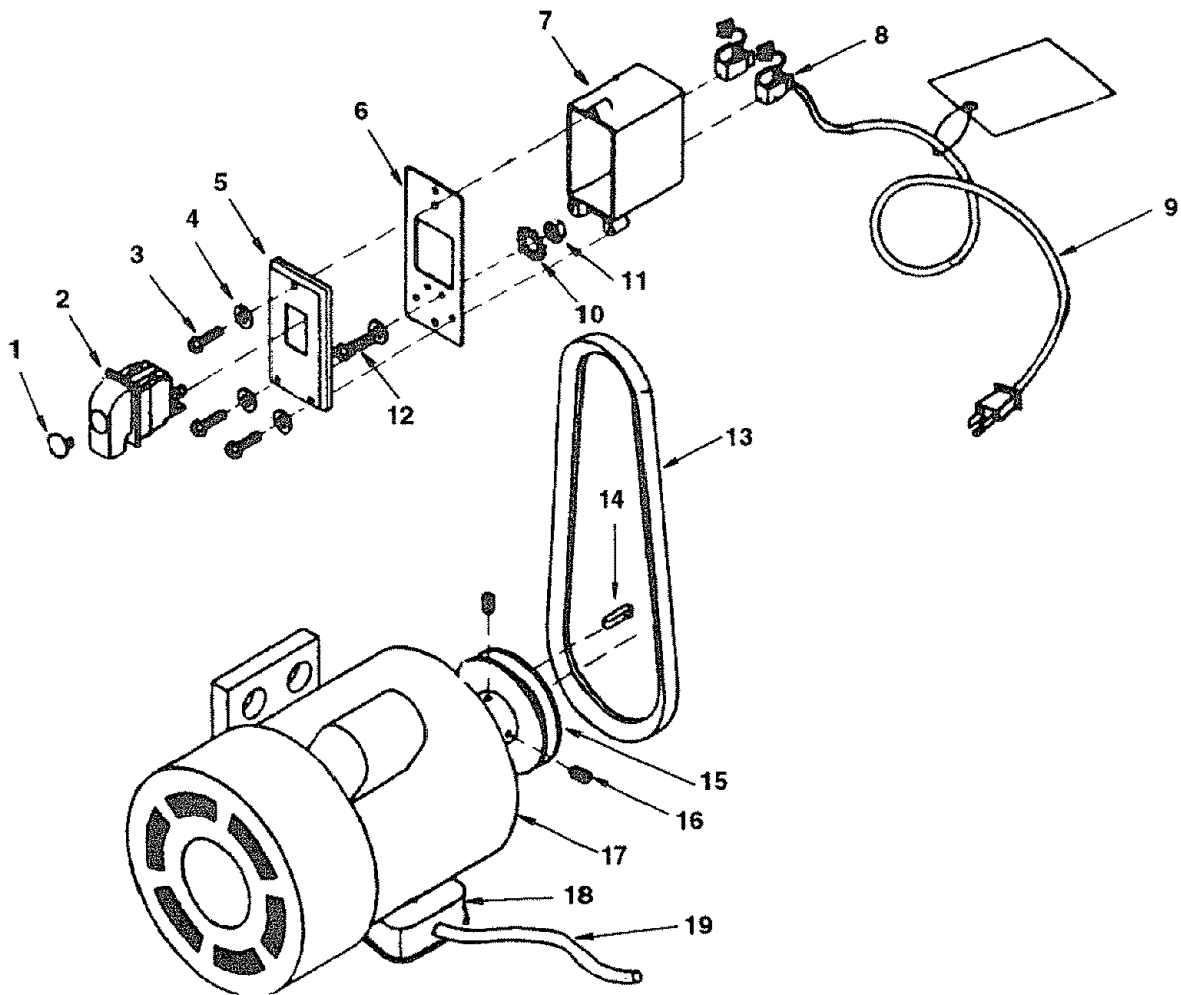

Always order by Part Number - Not by Key Number

Key No.	Part No.	Description
1	9-22255	Key Switch
2	824719	Switch Locking
3	817357-6	Screw Ty AB M4 x 1.6-18
4	STD551008	* Washer #8
5	824912	Plate Switch Bezel
6	824913	Plate Switch Box
7	824914	Box Switch
8	169123-15	Strain Relief 6P3-4
9	824911	Cord w/Plug
10	STD551208	* Lockwasher #8

Key No.	Part No.	Description
11	STD541008	* Nut #8-32
12	STD510803	* Screw Pan Hd #8-32 x 3/8
13	817393-6	V-Belt A-32
14	818654-8	Key
15	824931	Pulley
16	STD502503	* Screw Set 1/4-20 x 3/8
17	824910	Motor
18	69164	Strain Relief 6N3-4
19	824915	Cord Motor

* Standard hardware item, may be purchased locally

SEARS

owner's
manual

Model No.
113.232240
Jointer/Planer
with Legs and Motor

The model number of your 6-1/8
Inch Jointer/Planer will be found
on a plate attached to the base.

When requesting service or
ordering parts, always provide
the following information:

- Product Type
- Model Number
- Part Number
- Part Description

CONTRACTOR SERIES 6-1/8 INCH JOINTER/PLANER

For the repair or replacement parts you need

Call 7 am - 7 pm, 7 days a week

1-800-366-PART
(1-800-366-7278)

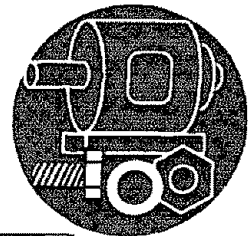

For in-home major brand repair service

Call 24 hours a day, 7 days a week

1-800-4-REPAIR
(1-800-473-7247)



For the location of a
Sears Repair Service Center in your area

Call 24 hours a day, 7 days a week

1-800-488-1222

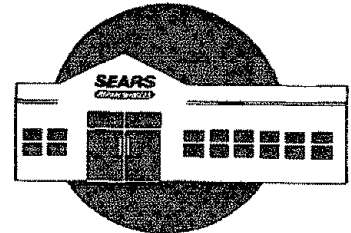

For information on purchasing a Sears
Maintenance Agreement or to inquire
about an existing Agreement

Call 9 am - 5 pm, Monday-Saturday

1-800-827-6655

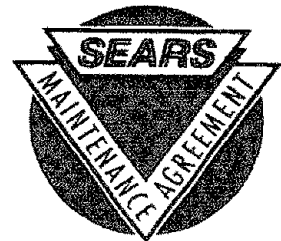

SEARS
REPAIR SERVICES
America's Repair Specialists

Sears, Roebuck and Co., Hoffman Estates, IL. 60179 U.S.A.