

Save This Manual
For Future Reference

SEARS

owner's
manual

MODEL NO.
113.236400
SCROLL SAW
Variable Speed
With Stand

Serial
Number _____

Model and serial numbers
may be found attached at rear
of saw.

You should record both model
and serial number in a safe
place for future use.

**FOR YOUR
SAFETY**
**READ ALL
INSTRUCTIONS
CAREFULLY**

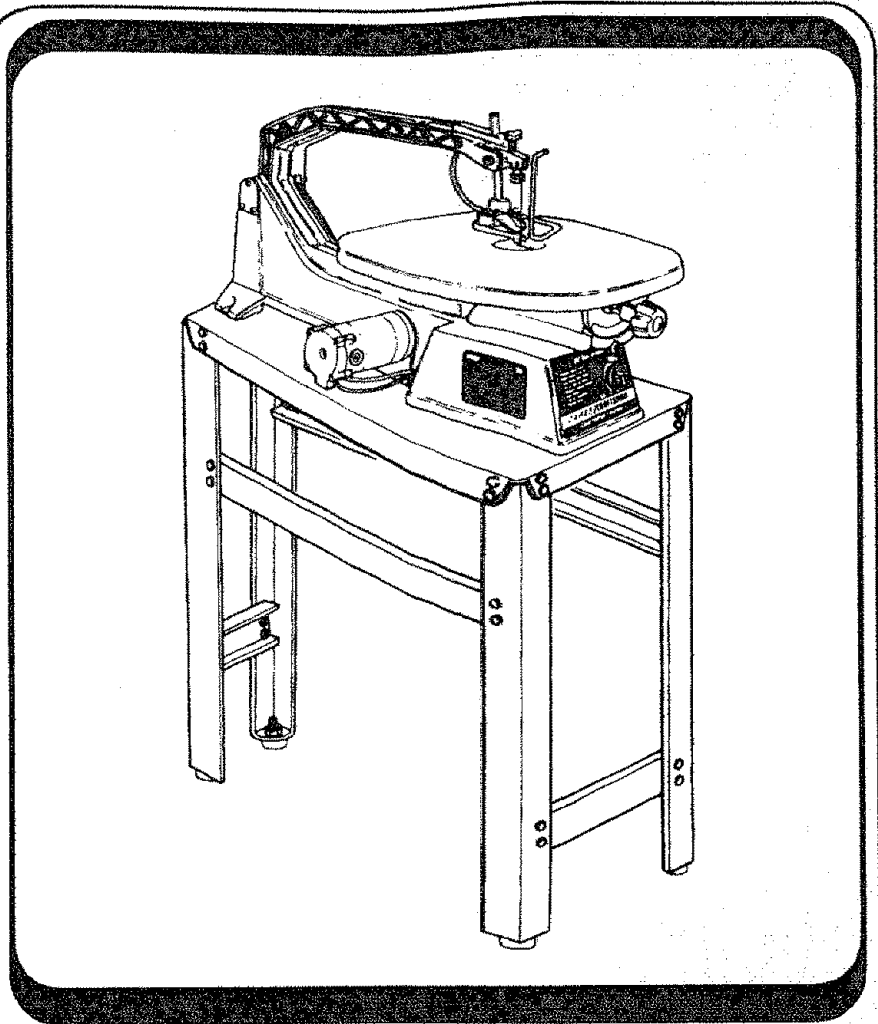

CRAFTSMAN® **CONTRACTOR SERIES** **20" VARIABLE SPEED** **SCROLL SAW**

- assembly
- operating
- repair parts

Sears, Roebuck and Co., Hoffman Estates, IL. 60179 U.S.A.

FULL ONE YEAR WARRANTY ON CRAFTSMAN BENCHTOP TOOLS

If this Scroll Saw fails due to a defect in material or workmanship, within one year from the date of purchase, RETURN IT TO THE NEAREST SEARS SERVICE CENTER IN THE UNITED STATES, and Sears will repair it, free of charge.

If this Scroll Saw is used for commercial or rental purposes, warranty will apply for ninety days from the date of purchase.

This warranty applies only while this product is in the United States.

This warranty gives you specific legal rights and you may also have other rights which vary from state to state.

Sears, Roebuck and Co., D817 WA Hoffman Estates, IL. 60179

safety instructions for scroll saw

Safety is a combination of common sense, staying alert and knowing how your scroll saw works. Read this manual to understand this saw.

Safety Signal Words

DANGER: means if the safety information is not followed someone **will** be seriously injured or killed.

WARNING: means if the safety information is not followed someone **could** be seriously injured or killed.

CAUTION: means if the safety information is not followed someone **may** be injured.

BEFORE USING THE SAW

WARNING: To avoid mistakes that could cause serious permanent injury, do not plug the saw in until the following steps are completed.

- Assembly and alignment. (See pages 7 - 14).
- Learn the use and function of the speed control ON-OFF knob, bevel lock knob, blade holders, blade support, work hold down, blade tension knob, and blade guard. (See pages 14 - 15)
- Review and understand all safety instructions and operating procedures in this manual.
- Review of the maintenance instructions for this saw. (See page 19)

Read the warning label below, found on the base of the saw.

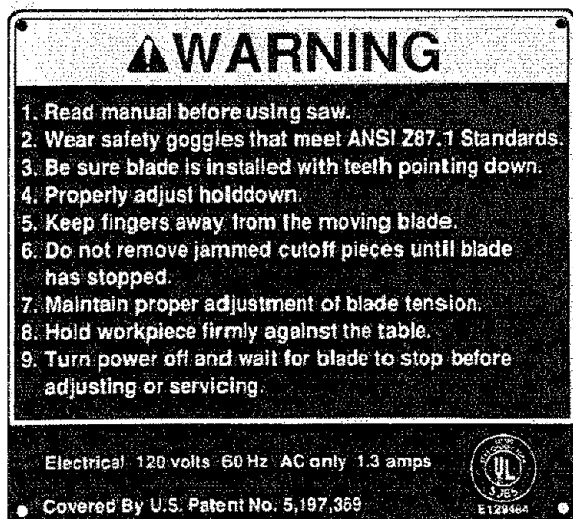

WHEN INSTALLING OR MOVING THE SAW

AVOID DANGEROUS ENVIRONMENT. Use the saw in a dry, indoor place, protected from rain. Keep work area well lighted.

To avoid injury from unexpected saw movement:

- Turn saw off and unplug cord before moving the saw.
- Always get help before moving the saw. The saw with stand, weighs 135 pounds. You could strain your back or the saw could fall on you.
- Put the saw on a firm level surface where there is plenty of room for handling and properly supporting the workpiece.
- Support the saw so the table is level and the saw does not rock.
- Bolt the stand to the floor if it tends to slip, walk, or slide during operations like cutting long heavy boards, or when using an auxiliary table.

NEVER STAND ON TOOL. Serious injury could occur if the tool tips or you accidentally hit the cutting tool. Do not store anything above or near the tool where anyone might stand on the tool to reach them.

To avoid injury or death from electrical shock:

- **GROUND THE SAW.** This saw has an approved 3 conductor cord and a 3-prong grounding type plug. Use only 3-wire, grounded outlets rated 120 volts, 15 amperes (amps). The green conductor in the cord is the grounding wire. To avoid electrocution, NEVER connect the green wire to a live terminal.
- Make sure your fingers do not touch the plug's metal prongs when plugging or unplugging the saw.

Before Each Use:

Inspect your saw.

DISCONNECT THE SAW. To avoid injury from accidental starting, unplug the saw, turn the switch "OFF" and lock the switch before changing the setup or removing covers, guards or blade.

CHECK FOR DAMAGED PARTS. Check for:

- Alignment of moving parts.
- Binding of moving parts.
- Broken parts.
- Stable mounting and
- Any other conditions that may affect the way the saw works.

If any part is missing, bent or broken in any way, or any electrical part doesn't work properly, turn off and unplug the saw. **REPLACE** damaged, missing or failed parts before using the saw again. **Keep Guards In Place** and in working order.

MAINTAIN TOOLS WITH CARE. Keep the saw clean for best and safest performance. Follow instructions under "Maintenance".

REMOVE ADJUSTING KEYS AND WRENCHES from tool before turning it on.

To avoid injury from jams, slips or thrown pieces:

- Choose the right size and style blade for the material and the type of cutting you plan to do.
- **USE ONLY RECOMMENDED ACCESSORIES.** (See page 20). Consult this owners manual for recommended accessories. Follow the instructions that come with the accessories. The use of improper accessories may cause risk of injury to person.
- Make sure the blade teeth point downward, toward the table.
- Make sure the blade tension is properly adjusted.
- Make sure the bevel lock knob is tight and no parts have excessive play.
- To avoid accidental blade contact, minimize blade breakage and provide maximum blade support, always adjust the blade hold-down and blade guard to just clear the workpiece.
- **KEEP WORK AREA CLEAN.** Cluttered areas and benches invite accidents. Floor must not be slippery.

To avoid burns or other fire damage, never use the saw near flammable liquids, vapors or gases.

PLAN AHEAD TO PROTECT YOUR EYES, HANDS, FACE AND EARS:

KNOW YOUR SAW. Read and understand the owners manual and labels affixed to the tool. Learn its application and limitations as well as the specific potential hazards peculiar to this tool.

To avoid injury from accidental contact with moving parts, don't do layout, assembly, or setup work on the saw while any parts are moving.

AVOID ACCIDENTAL STARTING. Make sure switch is "OFF" before plugging saw into a power outlet.

Plan Your Work.

- **USE THE RIGHT TOOL.** Don't force tool or attachment to do a job it was not designed to do.

- Use this scroll saw to cut only wood, woodlike products, plastics and nonferrous metals.

CAUTION: This saw is NOT designed for cutting ferrous metals like iron or steel. When cutting non-ferrous metals (brass, copper and aluminum, etc.), metal shavings can react with wood dust and start a fire. To avoid this:

- **Disconnect any type of dust collecting hose from the saw.**
- **Remove all traces of wood dust from on and around the saw.**
- **Remove all metal shavings from on or around the saw before sawing wood again.**

Dress for safety



Any power saw can throw foreign objects into the eyes. This can cause permanent eye damage. Wear safety goggles (not glasses) that comply with ANSI Z87.1 (shown on package). Everyday eyeglasses have only impact resistant lenses. They are not safety glasses. Safety goggles are available at Sears Retail Stores. Glasses or goggles not in compliance with ANSI Z87.1 could seriously hurt you when they break.

- Do not wear loose clothing, gloves, neckties or jewelry (rings, wristwatches). They can get caught and draw you into moving parts.
- Wear nonslip footwear.
- Tie back long hair.
- Roll long sleeves above the elbow.
- Noise levels vary widely. To avoid possible hearing damage, wear ear plugs or muffs when using saw for hours at a time.
- For dusty operations, wear a dust mask along with the safety goggles.

Inspect Your Workpiece.

Make sure there are no nails or foreign objects in the part of the workpiece to be cut.

Use extra caution with large, very small or awkward workpieces:

- Never use this tool to finish pieces too small to hold by hand.
- Use extra supports (tables, saw horses, blocks, etc.) for any workpieces large enough to tip when not held down to the table top.
- **Never** use another person as a substitute for a table extension, or as additional support for a workpiece or to help feed, support or pull the workpiece.

safety instructions for scroll saw

- When cutting irregularly shaped workpieces, plan your work so it will not pinch the blade. A piece of molding, for example must lay flat or be held by a fixture or jig that will not let it twist, rock or slip while being cut.
- Properly support round material such as dowel rods, or tubing. They have a tendency to roll during a cut, causing the blade to "bite". To avoid this, always use a "V" block.
- Cut only one workpiece at a time.
- Clear everything except the workpiece and related support devices off the table before turning the saw on.

Plan the way you will hold the workpiece from start to finish.

Do not hand hold pieces so small that your fingers will go under the work hold down. Use jigs or fixtures to hold the work and keep your hands away from the blade.

Avoid awkward operations and hand positions where a sudden slip could cause fingers or hand to move into the blade.

Don't Overreach. Keep good footing and balance.

Keep your face and body to one side of sawblade, out of line with a possible thrown piece.

SECURE WORK. Use clamps to hold work when practical. It's often safer than using your hand, and frees both hands to operate the tool.

Avoid awkward operations and hand positions where a sudden slip could cause fingers or hand to move into the blade.

DON'T OVERREACH. Keep good footing and balance.

Keep your face and body to one side of the blade, out of line with a possible thrown piece if the blade should break.

WHENEVER SAW IS RUNNING

WARNING: Don't let familiarity (gained from frequent use of your scroll saw) cause a careless mistake. A careless fraction of a second is enough to cause a severe injury.

Before starting your cut, watch the saw while it runs. If it makes an unfamiliar noise or vibrates a lot, stop immediately. Turn the saw off. Unplug the saw. Do not restart until finding and correcting the problem.

KEEP CHILDREN AWAY. Keep all visitors a safe distance from the saw. Make sure bystanders are clear of the saw and workpiece.

DON'T FORCE TOOL. It will do the job better and safer at its designed rate. Feed the workpiece into the saw blade only fast enough to let it cut without bogging down or binding.

Before freeing any jammed material:

- Push switch "OFF".
- Wait for all moving parts to stop.
- Unplug the saw.

When backing up the workpiece, the blade may bind in the kerf (cut). This is usually caused by sawdust clogging up the kerf. If this happens:

- Turn switch "OFF".
- Wait for all moving parts to stop.
- Unplug the saw.
- Remove the blade from the blade holders.
- Remove workpiece with blade from the table. Remove blade from workpiece.

Before removing loose pieces from the table, turn saw off and wait for all moving parts to stop.

BEFORE LEAVING THE SAW

Wait for all moving parts to stop.

MAKE WORKSHOP CHILD PROOF. Unplug the saw. Lock the shop or on/off knob. Store the key away from children and others not qualified to use the tool.

electrical connections

DANGER: To avoid electrocution:

1. Use only identical replacement parts when servicing. Servicing should be performed by a qualified service technician.
2. Do not use in rain or where floor is wet.

This tool is intended for indoor residential use only.

WARNING Do not permit fingers to touch the terminals of plug when installing or removing the plug to or from the outlet. If power cord is worn or cut, or damaged in any way, have it replaced immediately.

NOTE: The plug supplied on your tool may not fit into the outlet you are planning to use. Your local electrical code may require slightly different power cord plug connections. If these differences exist refer to and make the proper adjustments per your local code before your tool is plugged in and turned on.

In the event of a malfunction or breakdown, grounding provides a path of least resistance for electric current to reduce the risk of electric shock. This tool is equipped with an electric cord having an equipment grounding conductor and a grounding plug, as shown. The plug must be plugged into a matching outlet that is properly installed and grounded in accordance with all local codes and ordinances.

Do not modify the plug provided. If it will not fit the outlet, have the proper outlet installed by a qualified electrician.

A temporary adapter may be used to connect this plug to a 2-pole outlet, as shown, if a properly grounded outlet is not available. This temporary adapter should be used only until a properly grounded outlet can be installed by a qualified electrician. The green colored rigid ear, lug and the like, extension from the adapter must be connected to a permanent ground such as a properly grounded outlet box.

Improper connection of the equipment grounding conductor can result in a risk of electric shock. The conductor with insulation having an outer surface that is green with or without yellow stripes is the equipment grounding conductor. If repair or replacement of the electric cord or plug is necessary, do not connect the equipment-grounding conductor to a live terminal.

If the grounding instructions are not completely understood, or if you are in doubt as to whether the tool is properly grounded check with a qualified electrician or service personnel.

WARNING: If not properly grounded, this tool can cause an electrical shock, particularly when used in damp locations, in proximity to plumbing, or out of doors. If an electrical shock occurs there is the potential of a secondary hazard, such as your hands contacting the sawblade.

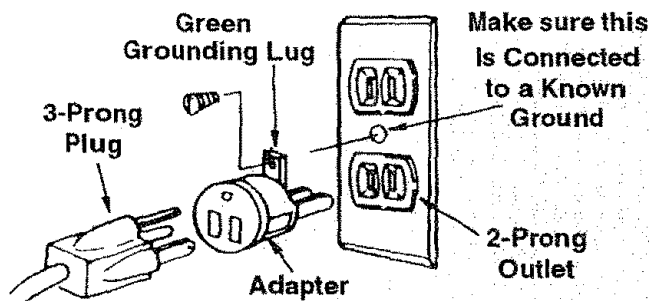
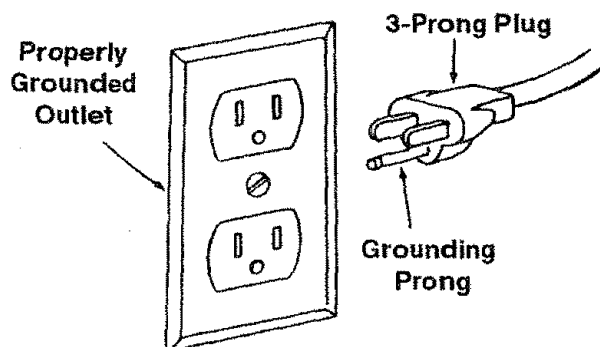

NOTE: The adapter illustrated is for use only if you already have a properly grounded 2-prong outlet.

Motor Safety Protection

1. Connect this tool to a power source with the appropriate voltage for your model and a 15-amp branch circuit with a 15-amp time delay fuse or circuit breaker. Using the wrong size fuse can damage the motor.
 2. This motor has an electronic control that regulates the speed and provides overload protection to the motor. If the motor fails to start after about 2 seconds, push the Speed Control Knob "OFF". Check that the blade moves freely up and down by rotating the motor using a screwdriver in the slot in the end of the motor shaft. If the blade is free, try starting the motor again. If the motor still will not start, refer to the "Motor Troubleshooting Chart".
 3. If the motor should stall during cutting, push the Speed Control Knob to the "OFF" position and unplug the tool. Check that the blade is free. Free the blade, if necessary. Plug in the power cord. The motor may now be restarted.
- NOTE:** If the internal overload protector has been tripped, pushing the Speed Control Knob "OFF" will reset it.
4. Most motor troubles may be traced to loose or incorrect connections, overload, low voltage (such as small size wire in the supply circuit) or to overly long supply circuit wire. Always check the connections, the load and the supply circuit whenever motor doesn't work well. Check wire sizes and length with the Wire Size Chart.

Wire Sizes

NOTE: Make sure the proper extension cord is used and is in good condition.

The use of any extension cord will cause some loss of power. To keep this to a minimum and to prevent overheating and motor burn-out, use the table shown to determine the minimum wire size (A.W.G.) extension cord.

Use only 3-wire extension cords which have 3-prong grounding type plugs and 3-pole receptacles which accept the tools plug.

Extension Cord Length	Wire Sizes Required for (A.W.G.)
0-50 Ft.	16

glossary of terms for woodworking

1. **Kerf** - the slot cut by the blade.
2. **Leading Edge** - the edge of the workpiece which is pushed into the blade first.
3. **Sawblade Path** - the area of the workpiece directly in line with and moving toward the sawblade edge.
4. **Bevel Cut** - the ability to tilt the table to make angle cuts. An angle cutting operation made through the face of the board.
5. **Blade Tooth Set** - the distance that the edge of the sawblade tooth is bent (or set) outward from the side of the blade.
6. **Trailing Edge** - the workpiece edge last cut by the sawblade.
7. **Workpiece** - the item on which the cutting operation is being performed.

table of contents

Warranty Information.....	2	Adjusting Guide Post	13
Safety Instructions For Scroll Saws	3	Adjusting Dust Blower.....	13
Electrical Information.....	4	Adjusting Blade Guard	13
Glossary of Terms for Woodworking	5	Quick Change Upper Blade Holder.....	14
Unpacking & Checking Contents	6	Getting to Know Your Scroll Saw	14
Assembly and Alignment	7	On-Off Knob	15
Assembling Stand	7	Choice of Blade and Speed	15
Mounting Saw to Stand	8	Basic Saw Operation	16
Installing Blade Box	8	Making Interior Scroll Cuts	19
Setting the Table for Horizontal or Bevel Cutting ...	9	Maintenance	19
Aligning Bevel Indicator	9	Replacing Motor Brushes	19
Removing or Replacing Blades	11	Recommended Accessories	20
Installing Plain End Blades	12	Troubleshooting	20
Installing Pin End Blades	12	Wiring Diagram	20
Adjusting Blade Guide	13	Repair Parts	21
Adjusting Hold-Down Foot	13	Service Information	24

unpacking and checking contents

TOOLS NEEDED

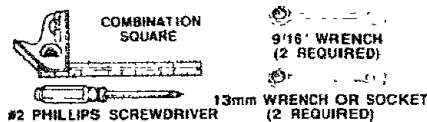

Remove the protective oil that is applied to the table top and edges of the table. Use any ordinary household type grease and spot remover.

WARNING: To avoid fire or health hazard, never use gasoline, naphtha or similar highly volatile solvents.

Apply a coat of automobile wax to the table.

Wipe all parts thoroughly with a clean, dry cloth.

Table of Loose Parts

	Qty.
A 20" Scroll Saw (completely assembled)	1
B Box, Blade	1
C Top, Stand	1
D Leg, Right Front	1
E Leg, Left Front	1
F Stiffener, Front	1
G Stiffener, Side	2
H Stiffener, Rear	1
J Leg, Left Rear	1
K Leg, Right Rear	1
L Owner's Manual	1
M Bag of Loose Parts (containing the following) ...	1
N Foot, Leveling 3/8	4
O Grommet	2
P Knob, Blade Change	1
Q Lockwasher, Ext M8	4
R Lockwasher, M8	32
S Nut, Hex 3/8-16	8
T Nut, Hex M8 x 1.25	34
U Screw, Hex M8 x 1.25 x 16	34
V Screw, Hex M8 x 1.25 x 30	2
W Rod, Blade Change	1
X Wrench, Hex "L"	1
Y Wrench, "T" Handle	1
Z Saw Blade	10

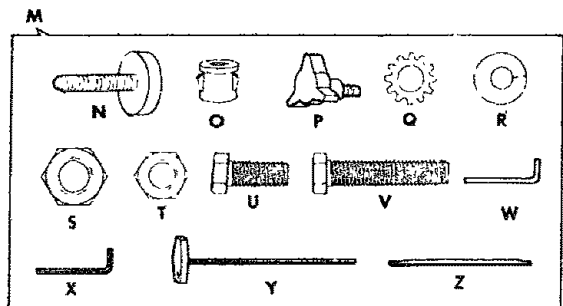
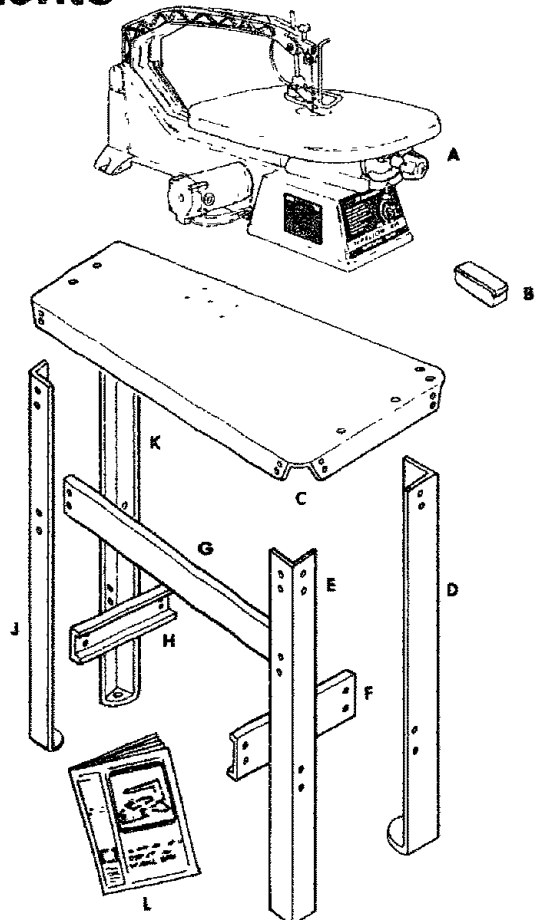

unpacking and checking contents

WARNING: For your own safety, never connect plug to power source outlet until all assembly steps are complete, and you have read and understand the safety and operating instructions.

WARNING: This saw is heavy. To avoid back injury, or injury from falling saw, get help whenever you have to lift or move the saw.

Separate all parts from packaging materials and check each item with illustration and "Table of Loose Parts". Make certain all items are accounted for before discarding any packaging material.

WARNING: To avoid injury, if any parts are missing, do not attempt to assemble the Scroll Saw, plug in the power cord, or turn the switch 'ON' until the missing parts are obtained and installed correctly.

assembly and alignment

ASSEMBLING STAND

1. From the loose parts bag, find the following hardware:

* Hex Head Bolt, M8 x 16.....	32
* Lockwasher M8	32
* Hex Nut M8	32
* Grommet	2
* Hex Nut 3/8-16	8
Leveling Foot	4
* Indicates item is shown actual size.	

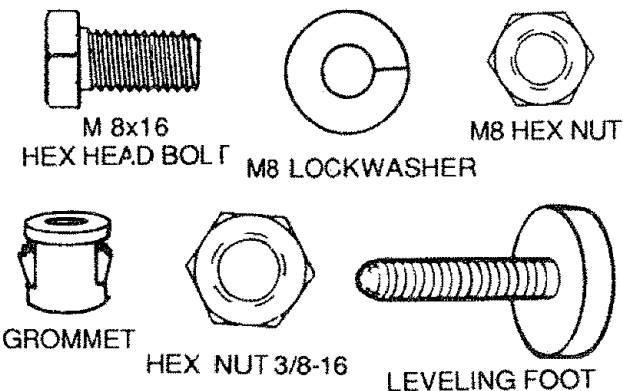

2. From the loose parts, find the following items:

A Stand Top	1
B Front Leg, Right	1
C Front Leg, Left	1
D Rear Leg, Right	1
E Rear Leg, Left	1
F Front Stiffener	1
G Rear Stiffener	1
H Side Stiffener	2

3. Assemble the stand as follows.

4. Lay the stand top upside down on the floor. Attach the legs to the inside of the top as shown. Use four (4) bolts, nuts and lockwashers for each leg. Hand tighten the hex nuts.

5. Attach the front, rear, and two side stiffeners to the legs. Two (2) bolts, nuts and lockwashers are used at each end of the stiffeners to attach them to the legs. Hand tighten the hex nut.

6. Install one 3/8-16 hex nut on each leveling foot and place through hole in the bottom of each leg, as shown. Install second 3/8-16 hex nut on each foot and tighten all nuts securely with a 9/16" wrench.

CAUTION: Use the leveling feet for leveling only. Do not use for height adjustment. Extend each foot only far enough to level the stand.

7. Set stand in an upright position. With stand resting level on floor, tighten all hardware with 13mm wrenches or sockets.

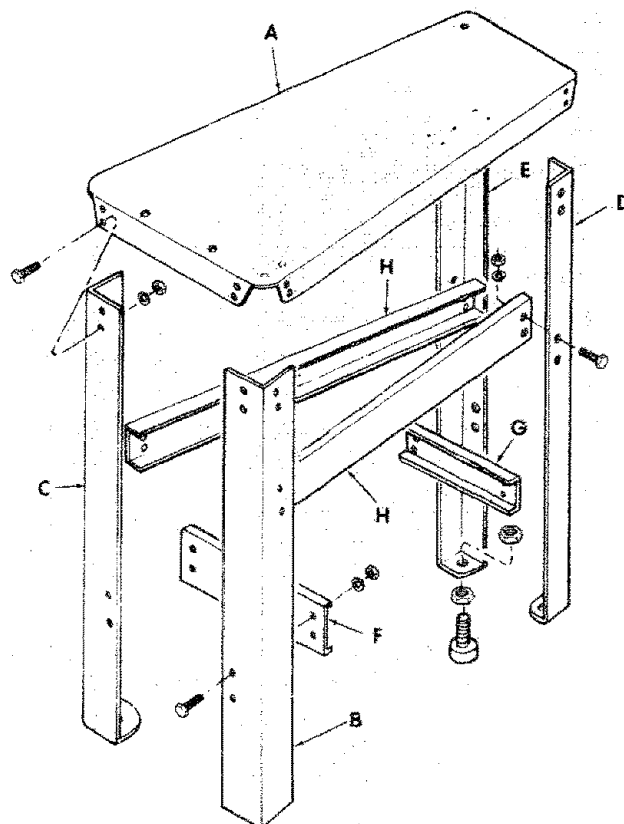

assembly and alignment

MOUNTING THE SAW TO THE STAND

1. From the loose parts bag, find the following items:

- * Hex Head Bolt, M8 x 30 2
- * Hex Head Bolt, M8 x 16 2
- Blade Box 1
- * M8 Hex Nut 2
- * External Lockwashers, M8 4

* Indicates item is shown actual size.

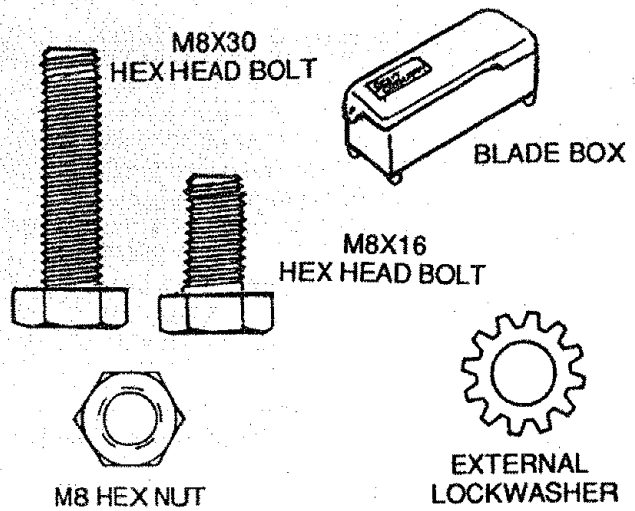

WARNING: This saw is heavy. To avoid back injury or injury from falling saw, get help whenever you need to lift or move the saw.

- Carefully lift and position the Scroll Saw on top of the stand. Line up the rear mounting holes in the saw with the holes at the narrow end of the stand. Use two (2) M8 x 30 bolts, external tooth lockwashers and hex nuts to attach the rear end of the Scroll Saw to the stand. Hand tighten only.
- Line up the front mounting holes. Use two (2) M8 x 16 bolts and external tooth lockwashers from the underside of the stand to mount the front end of the Scroll Saw. Tighten all four bolts securely using 13mm wrenches.

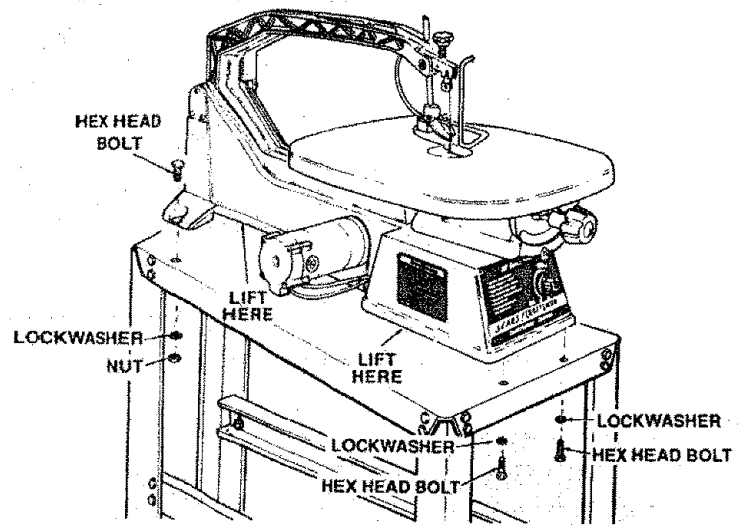

INSTALLING BLADE BOX

- Line up 5 bosses of the box with the holes located on the right side of the stand top as shown. Have the hinge side toward the saw.
- Open the lid. From inside the box, press down on the top of each boss to begin inserting each boss into a hole.
- Continue pressing each boss a little at a time, until the box is seated against the stand top.

INSTALLING GROMMETS

- Find the two (2) grommets in the loose parts. Insert these into the two holes at the right front corner of the stand top.
- Place the "T" handle wrench and the blade change rod in these grommets to store them for future use.

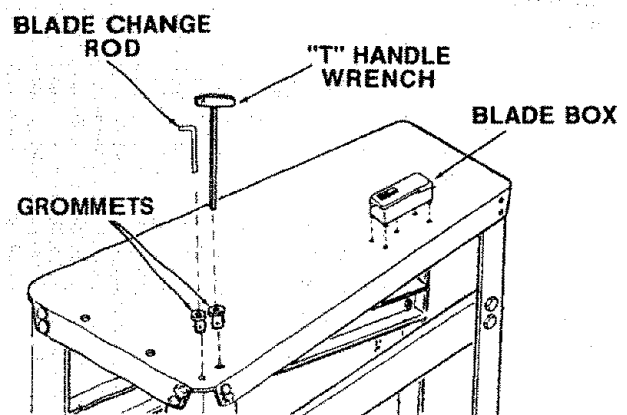

WARNING: For your own safety, never connect plug to power source outlet until all assembly steps are complete, and you have read and understand the safety and operating instructions.

Familiarize yourself with the controls and features of this Scroll Saw indicated in illustration.

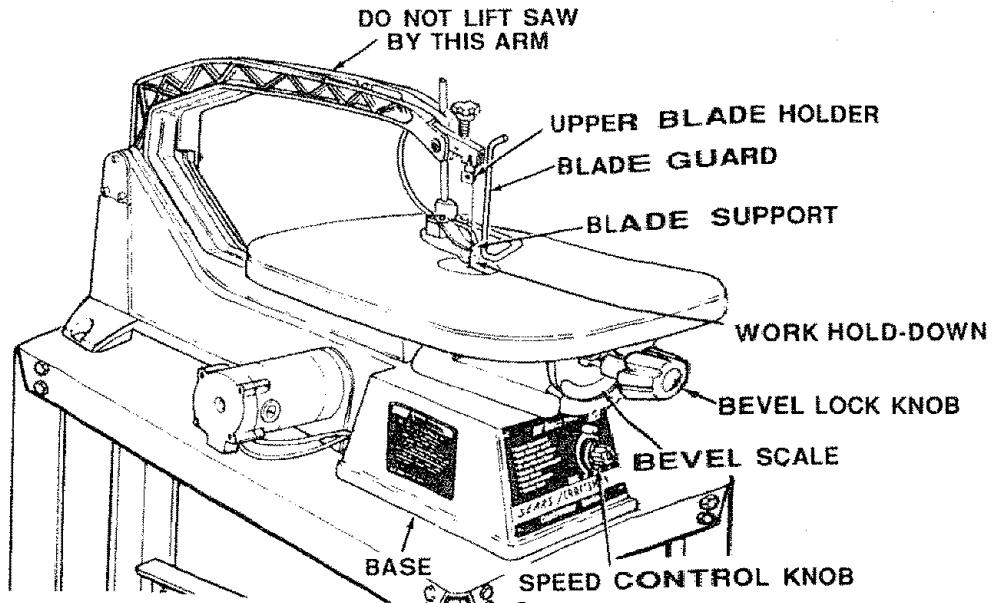

SETTING THE TABLE FOR HORIZONTAL OR BEVEL CUTTING

1. The Scroll Saw work table can be tilted to the right up to 45° for bevel cutting and up to 34° to the left by removing 90° stop bolt and nut.
2. A bevel scale is provided under the work table as a convenient reference for setting the approximate table angle for bevel cutting.

When greater precision is required, make trial cuts and adjust the table as necessary for your requirements.

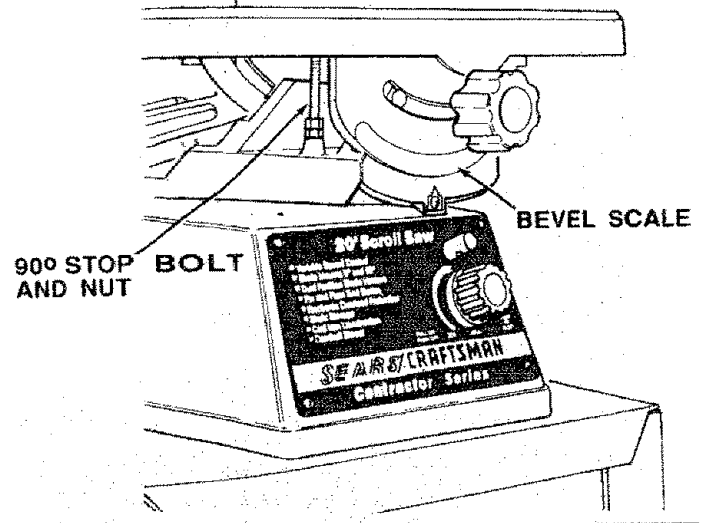

TO ALIGN THE BEVEL INDICATOR

1. Loosen the table bevel lock knob and move the table until it is approximately perpendicular, or at a right angle, to the blade.

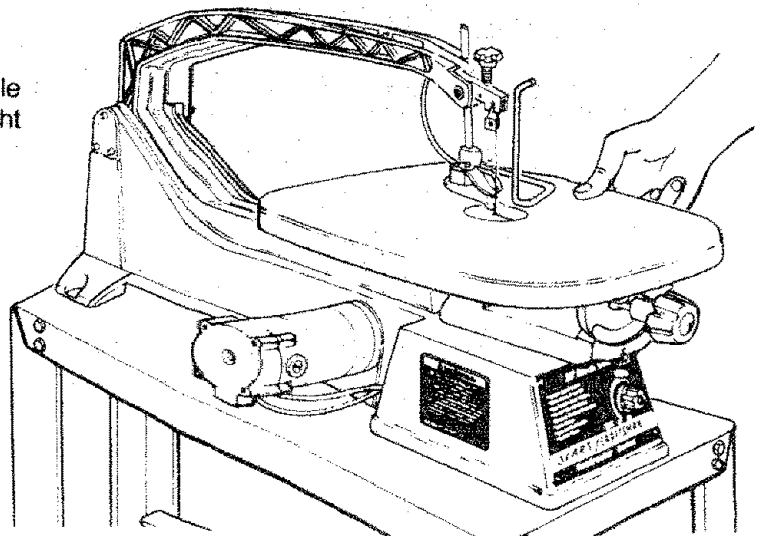

assembly and alignment

2. Remove blade support by loosening the screw on the top of the blade support with the 4mm hex "L" wrench provided.
3. Remove hold-down by loosening the screw to the rear of hold-down foot.

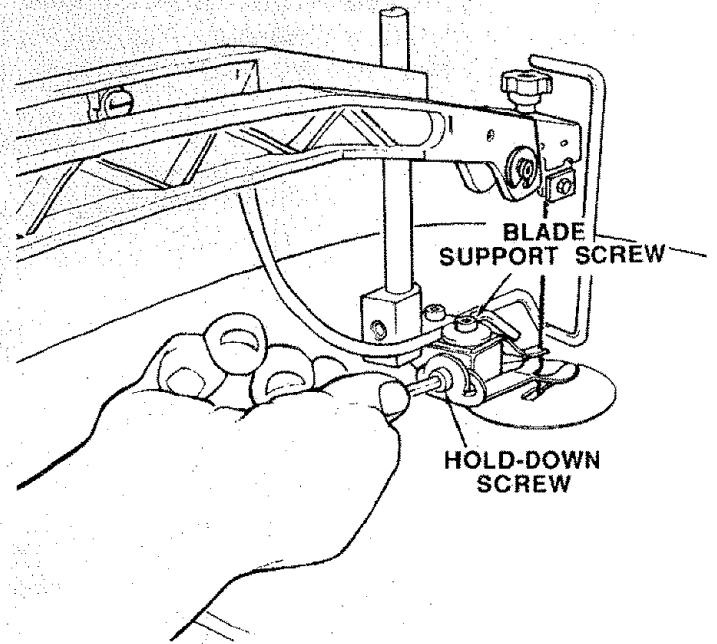

-
4. Use a small square to check the angle between the table and the blade. If the space between the square and the blade is not uniform, the table must be adjusted.

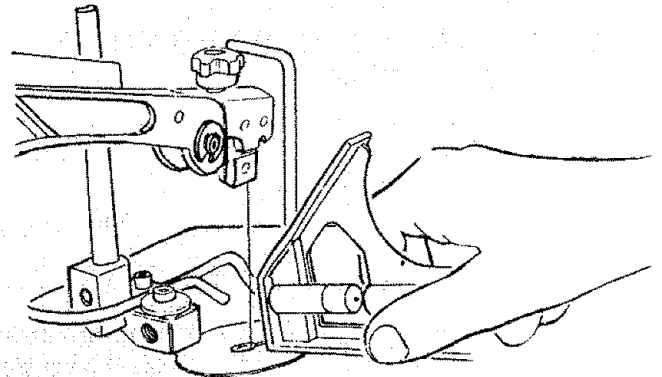

-
5. Loosen the bevel lock knob and adjust table until the space between the square and the blade is uniform. Tighten the bevel lock knob.
The table should now be approximately 90° to the blade.

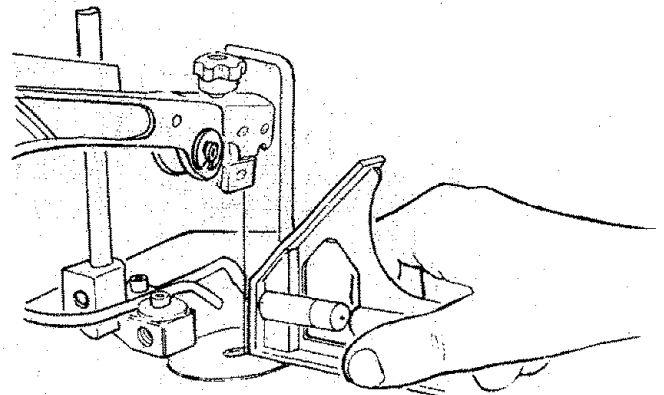

Adjust 90° stop bolt and lower hex nut until head of bolt rests against underside of table. Lock upper hex nut against lower hex nut using 13mm wrenches.

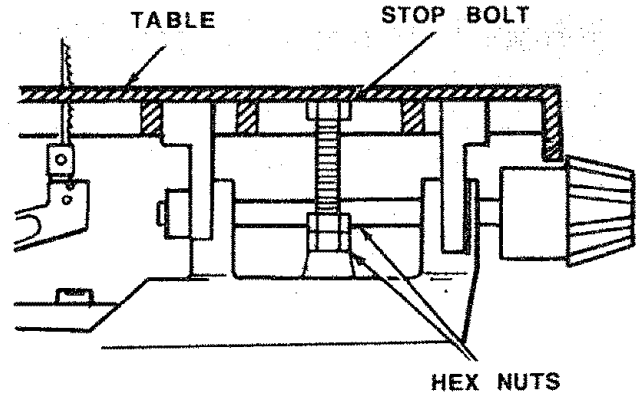

6. Loosen the screw holding the bevel scale pointer and adjust pointer to 0°. Tighten screw.

Remember, the bevel scale is a convenient guide, but should not be relied upon for precision.

Reassemble the blade support and hold down.

Make trial cuts in scrap wood to determine if your angle settings are correct. Adjust the table as required.

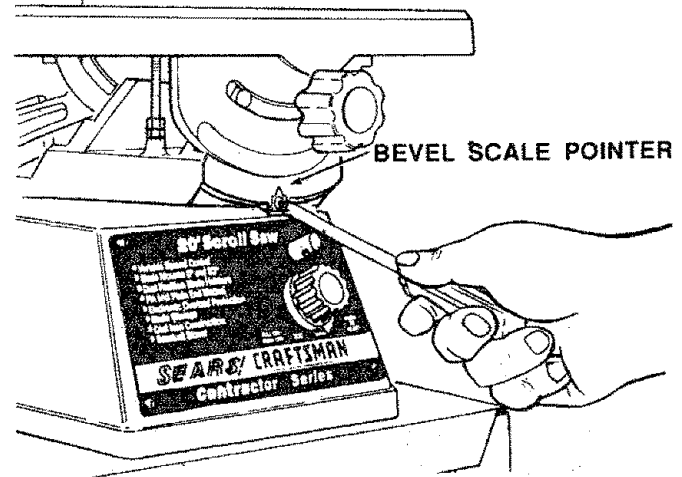

REMOVING OR REPLACING BLADES

WARNING: To avoid injury from unexpected tool movement, always unplug the saw before installing, removing, or replacing the blade.

1. Unplug power cord from outlet.
2. Remove table insert. (Push up from underside of table.)
3. Release blade tension by turning blade tension knob counterclockwise.

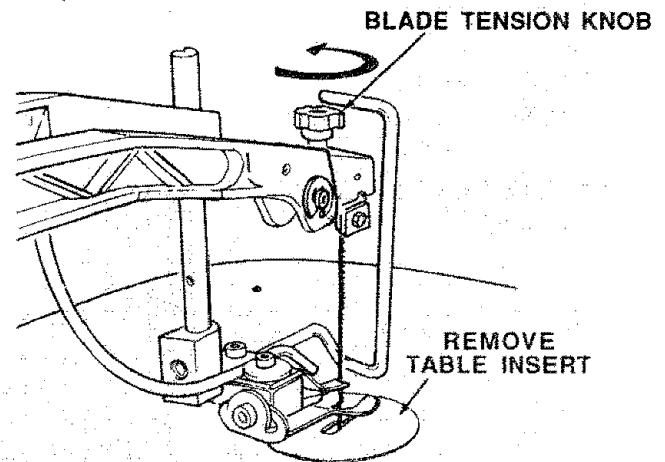

4. Insert the blade change rod through the hole above the blade holder, and loosen the hex socket screw of the blade holder with the "T" wrench.
5. Remove blade from upper blade holder.

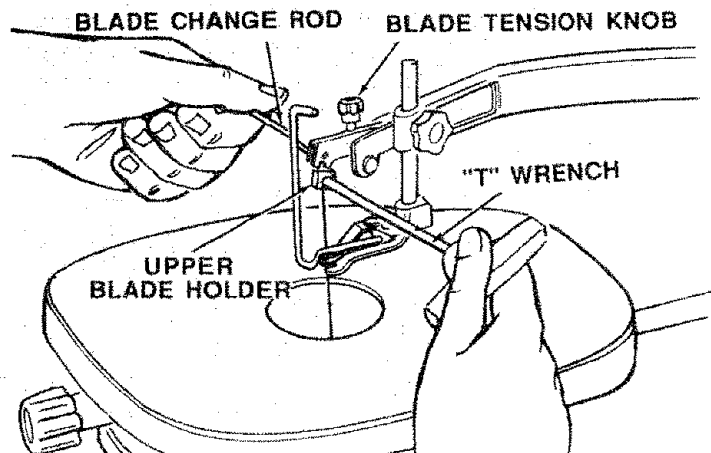

assembly and alignment

- Loosen the lower blade holder hex socket screw in the same way as the upper blade holder in step 5. Leave blade change rod in position.

INSTALLING PLAIN END BLADES

NOTE: Saw comes set up for plain end blades. If you are going to use pin end blades, refer to the instructions under "Installing Pin End Blades" below.

- Install the new blade through the insert hole in the table, and into the lower blade holder. Position the lower end of the blade in the lower blade holder, at the bottom of the blade clamp and against the hex socket screw.
- Tighten the hex socket screw using the "T" wrench, while holding the blade change rod in position.
- Use the same procedure to install the blade into the upper blade holder. Before tightening the socket hex screw, adjust the position of the upper blade holder by turning the blade tension knob until the end of the blade is near the top of the blade holder.
- Remove the "T" wrench and the blade change rod from the blade holder.
- Tighten the blade tension knob (clockwise) until the blade is tensioned.
- Reinstall the table insert with the slot toward the front of the table.

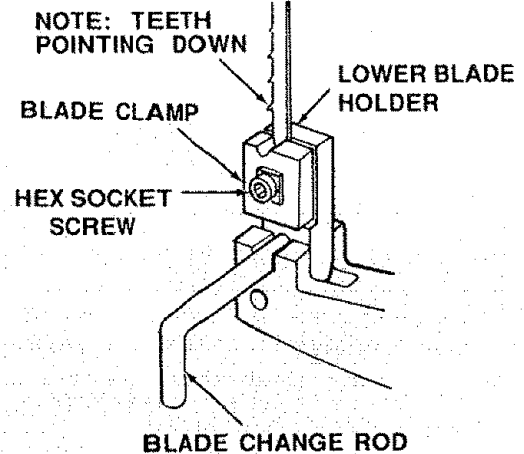
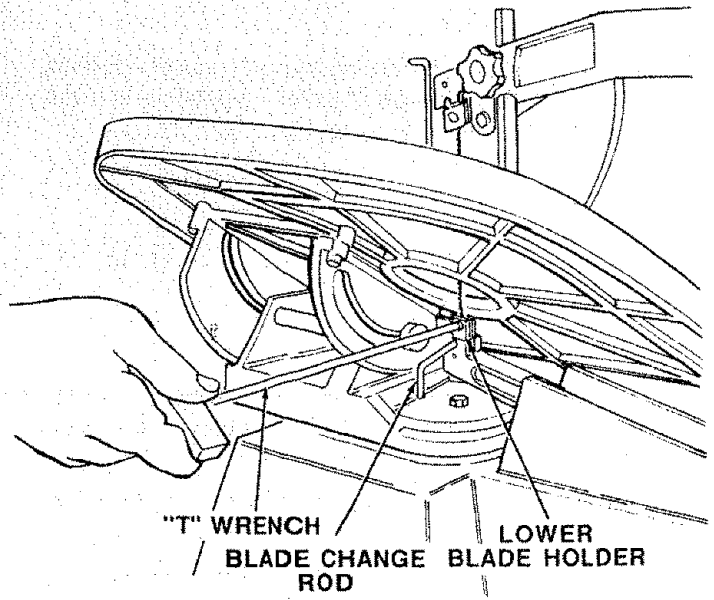

INSTALLING PIN END BLADES

NOTE: For pin end blades, the clamp part of the blade holders needs to be repositioned.

- Release blade tension by turning blade knob counter-clockwise.
- Use the "T" handle wrench to remove the hex socket screw and clamp from the upper blade holder. Reinstall the clamp so that the square boss goes into the recess in the blade holder and the "V" notches line up.
- Tighten the hex socket screw.
- Repeat this procedure on the lower blade holder.
- Install the blade through the insert opening. Have the teeth pointing down. Engage the pin into the "V" notch of the lower blade holder.
- Pull up on the blade and engage the upper pin in the notch of the upper blade holder.
- Follow the tensioning procedure for plain end blades to complete the installation.

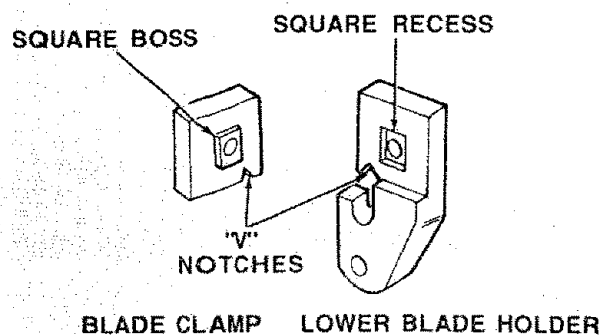
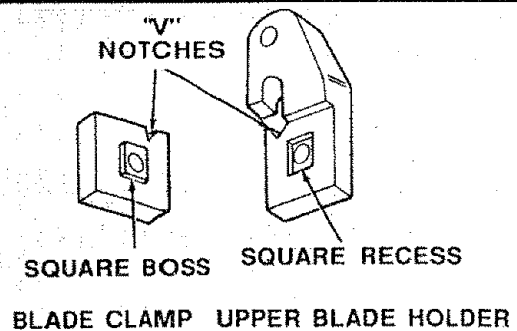

ADJUSTING BLADE GUIDE

The blade may be supported from the rear and held in line to prevent excessive bending while cutting. Accurate work and minimum blade breakage, especially with thin blades, depends on proper adjustment of the blade guide.

The socket head screw holds the blade guide to the blade guide bracket. The guide should be adjusted forward until the 'V'-slot barely touches the rear edge of the blade with 'C'-Arm in its top position. Then tighten screw. The blade should not rub in the slot while running free. Excessive friction work hardens the back edge of the blade and reduces blade life. Pressure on the work will push the blade back against the guide while cutting.

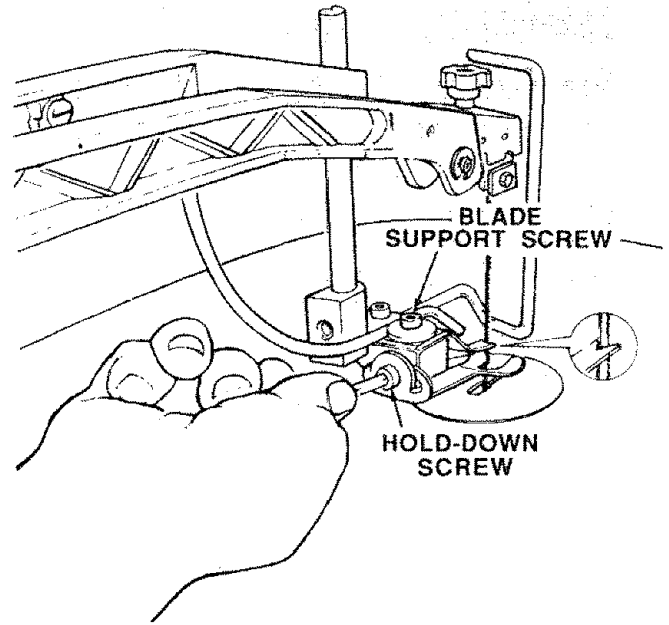

ADJUSTING WORK HOLD-DOWN FOOT

The purpose of the work hold-down foot is to hold the work against the table so that it is less likely to lift with the up stroke of the blade. It should lie flat on the work with the front prongs straddling the blade.

The work hold-down foot is attached to the blade guide bracket. The height of the work hold-down foot is adjusted by loosening the work hold-down knob and moving the guide post up or down.

When the table is tilted, the work hold-down foot can be adjusted by loosening the screw and adjusting the foot to the same angle as the table. The work hold-down foot should always be adjusted as close to the work as possible.

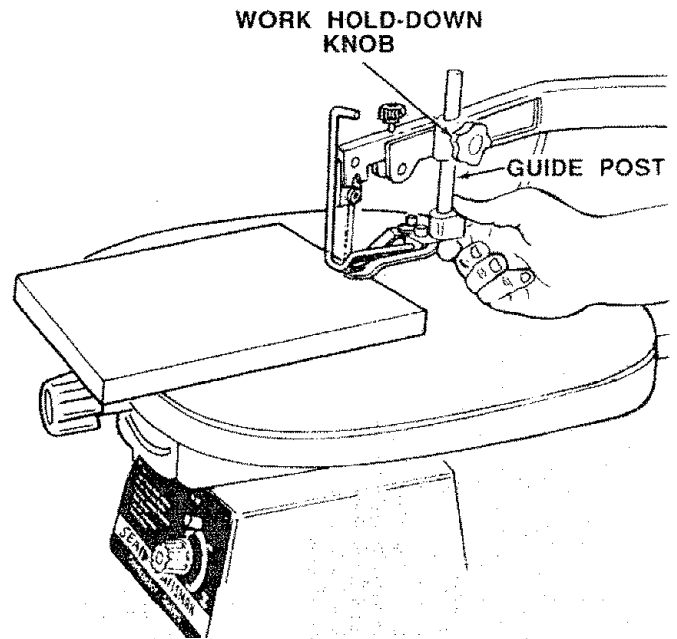

ADJUSTING DUST BLOWER

The dust blower may be moved to direct air to the most effective point on the cutting line by loosening screw.

NOTE: This same screw is used to adjust the blade guard.

ADJUSTING BLADE GUARD

The blade guard should always be adjusted parallel to the saw blade. Loosen screw to reposition guard. Retighten screw when guard is in the correct position.

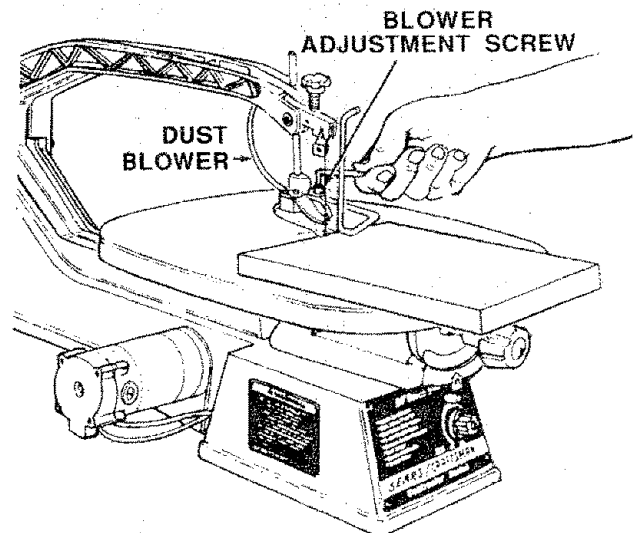

assembly and alignment

QUICK CHANGE UPPER BLADE HOLDER (Lock Knob With Screw)

This accessory is supplied in the loose parts bag. It enables the user to remove the upper portion of the blade quickly when making interior cuts in a workpiece.

1. Remove the hex socket screw in the upper blade holder with the "T" wrench; use the blade change rod for additional support.
2. Replace the screw with the quick release blade knob and reinstall blade.

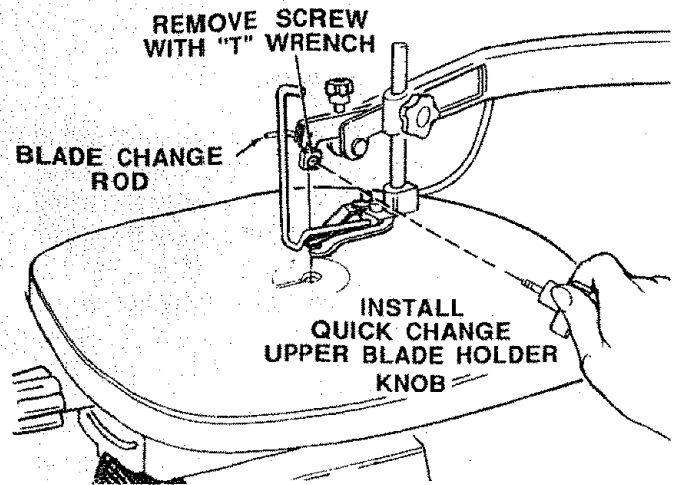

getting to know your scroll saw

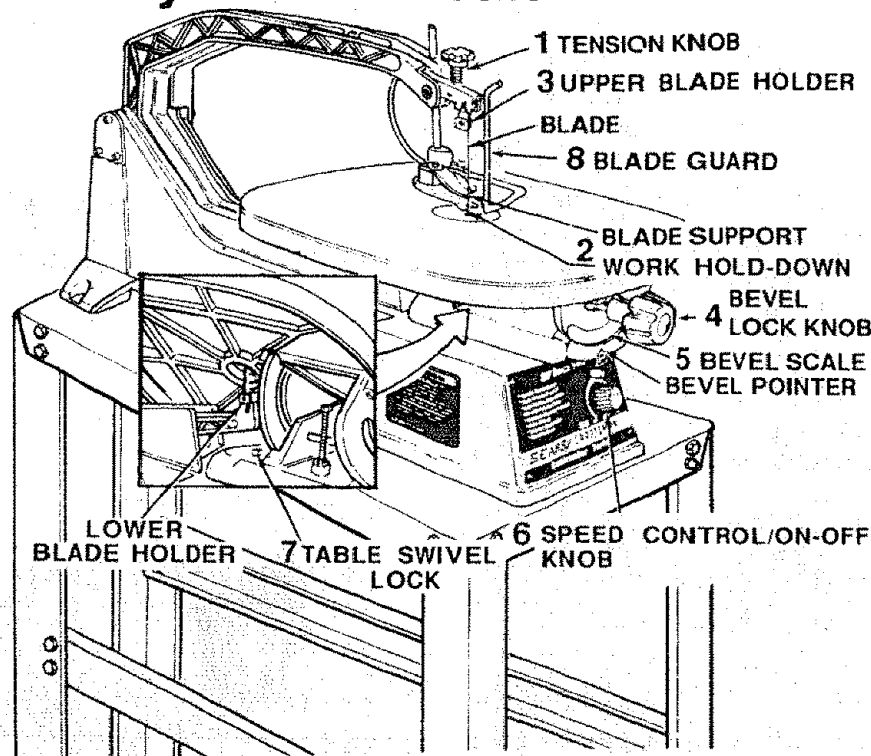

1. TENSION KNOB - Tightening the knob (clockwise) will increase the tension on the blade. Loosening it (counterclockwise) will decrease the tension.
2. WORK HOLD-DOWN AND BLADE SUPPORT - Provides added control of workpiece, protection for operator and support for the blade.
3. BLADE HOLDERS - Retain and position the blade.
4. BEVEL LOCK KNOB - Loosening knob allows blade and housing assembly to tilt up to 45° right and 35° left for bevel cuts.
5. BEVEL SCALE - Shows degree blade is tilted for bevel cutting.
6. SPEED CONTROL/ON-OFF KNOB - For speed control setting, refer to the "Choice of Blade and Speed" table. The On- Off Knob has a locking feature. THIS FEATURE IS INTENDED TO HELP PREVENT UNAUTHORIZED USE BY CHILDREN AND OTHERS.
7. TABLE SWIVEL LOCK - Allows table to be tilted at compound angles and locked in position.
8. BLADE GUARD - Defines area of moving blade.

ON-OFF KNOB

1. To turn machine 'ON', place fingers on Speed Control/On-Off Knob and pull out.

NOTE: A hesitation before blade movement, after machine is turned 'ON', is a normal condition of this saw.

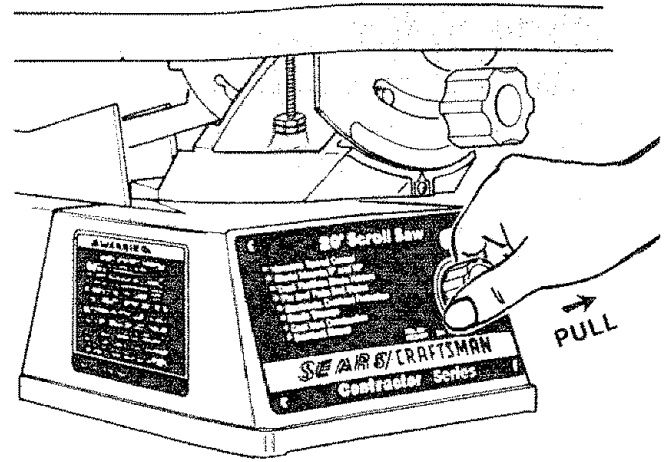

2. To turn machine 'OFF', push in Speed Control/On-Off Knob. NEVER LEAVE THE MACHINE UNATTENDED UNTIL IT HAS COME TO A COMPLETE STOP.

The variable speed control may be adjusted to the approximate speeds identified on the control panel. Suggested speeds are identified under "Choice of Blade and Speed". Turn the control knob clockwise (↻) to increase strokes per minute and counter-clockwise (↺) to reduce the strokes per minute.

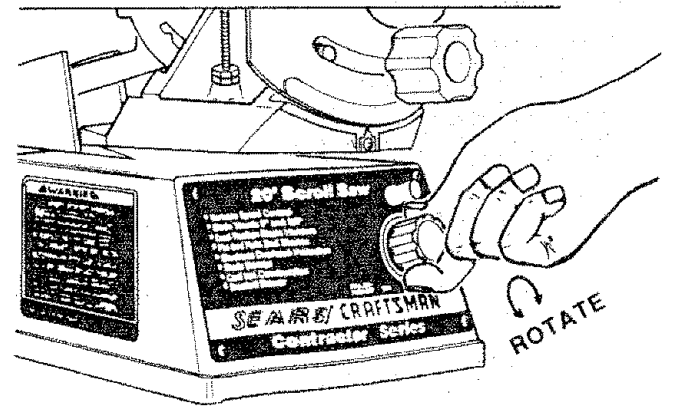
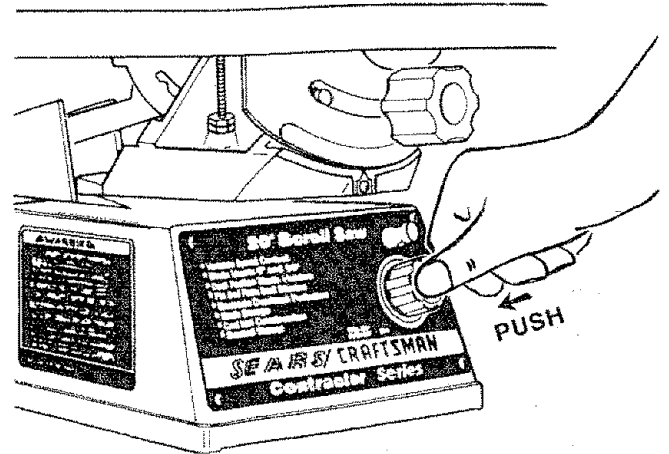

3. To lock knob in 'OFF' position, install a padlock through the post above the knob as illustrated, and lock the padlock. (Padlock is not supplied with the saw.)

WARNING: For your own safety, always push the knob 'OFF' when machine is not in use. Also, in the event of a power failure (all of your lights go out), push knob 'OFF'. 'LOCKOUT' your knob with a padlock as shown. This will prevent the machine from starting up again when the power comes back on.

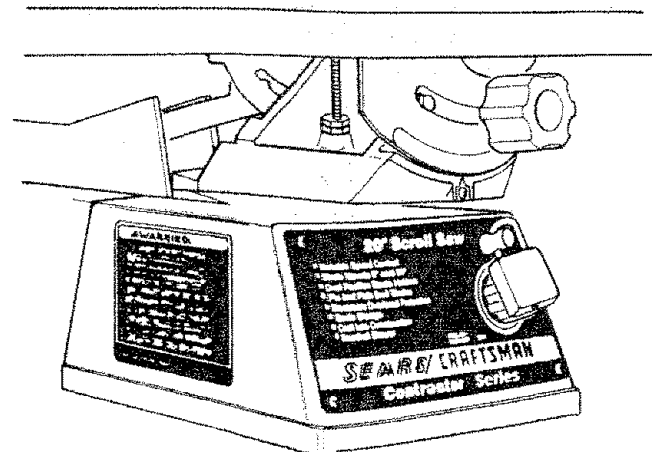

getting to know your scroll saw

CHOICE OF BLADE AND SPEED

Your scroll saw accepts a wide variety of 5" plain end and pin end blades. As a general guide:

1. Use a finer tooth blade for cutting thin workpieces, when a smoother cut is required, for hard materials, or when using slower saw speeds.

2. Use a coarser tooth blade for cutting thicker workpieces, when making straight cuts, for medium to soft materials or when using faster saw speeds.
3. Use a blade that will have at least 2 teeth in the material at all times.
4. Use thin, narrow blades for tight radius work, and thick, wide blades for large curves and straight cuts.

Listed below are examples of some blades and their intended uses:

Teeth/Inch	Width	Thickness	Speed	Application
20 15	.029" .110"	.012" .018"	400-600	Tight radius work; 3/32" to 1/8" wood veneer, wood, bone, fiber, plastics, non-ferrous metals, etc.
12.5	.038"	.016"	600-1200	Close radius cutting in materials 3/32" to 1/2" thick. Good for hard and soft wood, bone, horn, plastics, etc.
11.5 10	.053" .110"	.018" .018"	1200-2000	For hard and soft woods and woodlike products 3/16" and up.

basic saw operations

BEFORE EACH USE:

Inspect your saw.

DISCONNECT THE SAW. To avoid injury from accidental starting, unplug the saw, push the switch "OFF" and lock the switch before changing the setup or removing covers, guards or blade.

CHECK DAMAGED PARTS. Check for:

- alignment of moving parts.
- binding of moving parts.
- broken parts.
- stable mounting, and
- any other conditions that may affect the way the saw works.

If any part is missing, bent or broken in any way, or any electrical part doesn't work properly, turn off and unplug the saw. **REPLACE** damaged, missing or failed parts before using the saw again.

MAINTAIN TOOLS WITH CARE.

Keep the saw clean for the best and safest performance. Follow instructions for lubricating.

REMOVE ADJUSTING KEYS AND WRENCHES from tool before turning it on.

To avoid injury from jams, slips or thrown pieces.

- Choose the right size and style blade for the material and the type of cutting you plan to do.

- **USE ONLY RECOMMENDED ACCESSORIES.** (See page 20). Consult this Owner's manual for recommended accessories. Follow the instructions that come with the accessories. The use of improper accessories may cause risk of injury to persons.

- Make sure the blade teeth point downward, toward the table.

- Make sure the blade tension is properly adjusted.
- Make sure the bevel lock knob is tight and no parts have excessive play.

- To avoid accidental blade contact, minimize blade breakage and provide maximum blade support, always adjust the blade hold-down and blade guard to just clear the workpiece.

- **KEEP WORK AREA CLEAN.** Cluttered areas and benches invite accidents. Floor must not be slippery.

To avoid burns or other fire damage, never use the saw near flammable liquids, vapors or gases.

PLAN AHEAD TO PROTECT YOUR EYES, HANDS, FACE, EARS

KNOW YOUR SAW. Read and understand the owners manual and labels affixed to the tool. Learn its applications and limitations as well as the specific potential hazards peculiar to this tool.

To avoid injury from accidental contact with moving parts, don't do layout, assembly or setup work on the saw while any parts are moving.

AVOID ACCIDENTAL STARTING. Make sure switch is "OFF" before plugging saw into a power outlet.

Plan your work.

- USE THE RIGHT TOOL. Don't force tool or attachment to do a job it was not designed to do.
- Use this scroll saw to cut only wood, wood like products, plastics and non-ferrous metals.

CAUTION: This saw is **NOT** designed for cutting ferrous metals like iron or steel. When cutting non-ferrous metals (brass, copper and aluminum, etc.), metal shavings can react with wood dust and start a fire. To avoid this:

- Disconnect any dust collecting hose from the saw.
- Remove all traces of wood dust from inside the saw.
- Remove all traces of metal dust from on or around the saw before sawing wood again.

Dress for safety.

Any power tool can throw foreign objects into the eyes. This can cause permanent eye damage. Wear safety goggles (not glasses) that comply with ANSI Z87.1 (shown on package). Everyday eyeglasses have only impact resistant lenses. They are not safety glasses. Safety goggles are available at Sears retail catalog stores. Glasses or goggles not in compliance with ANSI Z87.1 could seriously hurt you when they break.

- Do not wear loose clothing, gloves, neckties or jewelry (rings, wrist watches). They can get caught and draw you into moving parts.
- Wear nonslip footwear.
- Tie back long hair.
- Roll long sleeves above the elbow.
- Noise levels vary widely. To avoid possible hearing damage, wear ear plugs or muffs when using saw for hours at a time.
- For dusty operations, wear a dust mask along with the safety goggles.

Inspect your workpiece

Make sure there are no nails or foreign objects in the part of the workpiece to be cut.

Use extra caution with large, very small or awkward workpieces:

- Never use this tool to finish pieces too small to hold by hand.
- Use extra supports (tables, saw horses, blocks, etc.) for any workpieces large enough to tip when not held down to the table top.
- NEVER use another person as a substitute for a table extension, or as additional support for a workpiece or to help feed, support or pull the workpiece.
- When cutting irregularly shaped workpieces, plan

your work so it will not pinch the blade. A piece of molding, for example, must lay flat or be held by a fixture or jig that will not let it twist, rock or slip while being cut.

- Properly support round material such as dowel rods, or tubing. They have a tendency to roll during a cut, causing the blade to "bite". To avoid this, always use a "V" block.
- Cut only one workpiece at a time.
- Clear everything except the workpiece and related support devices off the table before turning the saw on.

Plan the way you will hold the workpiece from start to finish.

Do not hand hold pieces so small that your fingers will go under the work hold-down. Use jigs or fixtures to hold the work and keep your hands away from the blade.

SECURE WORK. Use clamps to hold work when practical. It's often safer than using your hand, and frees both hands to operate the tool.

Avoid awkward operations and hand positions where a sudden slip could cause fingers or hand to move into the blade.

DON'T OVERREACH. Keep good footing and balance. Keep your face and body to one side of blade, out of line with a possible thrown piece if the blade should break.

WHENEVER SAW IS RUNNING

WARNING: Don't let familiarity (gained from frequent use of your saw) cause a careless mistake. A careless fraction of a second is enough to cause a severe injury.

Before starting your cut, watch the saw while it runs. If it makes an unfamiliar noise or vibrates a lot, stop immediately. Turn the saw off. Unplug the saw. Do not restart until finding and correcting the problem.

KEEP CHILDREN AWAY. Keep all visitors a safe distance from the saw. Make sure bystanders are clear of the saw and workpiece.

DON'T FORCE TOOL. It will do the job better and safer at its designed rate. Feed the workpiece into the saw blade only fast enough to let it cut without bogging down or binding.

Before freeing any jammed material:

- Push switch "OFF".
- Lock the switch.
- Unplug the saw.
- Wait for all moving parts to stop.

When backing up the workpiece, the blade may bind in the kerf (cut). This is usually caused by sawdust clogging up the kerf. If this happens:

- Push switch "OFF".
- Lock the switch.

basic saw operations

- Unplug saw.
- Wait for all moving parts to stop.
- Remove the blade from the blade holders.
- Remove workpiece with blade from the table. Remove blade from workpiece.

Before removing loose pieces from the table, turn saw off and wait for all moving parts to stop.

OPERATION OF YOUR SCROLL SAW

PLEASE, read and understand the following items about your scroll saw before attempting to use the saw.

1. Do not force workpiece into the blade. Allow the saw to cut the workpiece by guiding the wood into the blade.
2. The blade teeth cut wood ONLY on the down stroke.
3. You must guide the wood into the blade slowly because the teeth of the blade are very small and they can only remove wood when they are on the down stroke.
4. There is a learning curve for each person using this saw. During that period of time, it is expected that some blades will break until you learn how to use the saw and receive the greatest benefit from the blades.
5. Best results are achieved when cutting wood less than one inch thick.
6. When cutting wood thicker than one inch the user must guide the wood very, very slowly into the blade, and take extra care not to bend or twist the blade while cutting, in order to maximize blade life.
7. Teeth on scroll saw blades wear out and as such must be replaced frequently for best cutting results. Scroll saw blades generally stay sharp for 1/2 hour to 2 hours of cutting.
8. To get accurate cuts, be prepared to compensate for the tendency of the blade to follow the wood grain as you are cutting.
9. This scroll saw is intended to cut wood, wood like materials, or non-ferrous metal.

BEFORE LEAVING THE SAW:

Wait for all moving parts to stop.

MAKE WORKSHOP CHILD-PROOF. Unplug the saw. Lock the shop or on/off knob. Store the key away from children and others not qualified to use the tool.

10. When choosing a blade to use with your scroll saw, consider the following carefully.
 - Very fine, narrow blades should be used to scroll cut in thin wood 1/4 inch thick or less.
 - To cut wood over 1/4 inch thick, use wider blades.
 - Most blade packages state the size or thickness of wood which that blade is intended to cut, and the minimum radius which can be cut with that blade.
 - Wider blades can't cut curves as tight or small as thinner blades.
 - Narrower blades work well only on thinner wood material.
11. When selecting the cutting speed, keep the following in mind:
 - Slower speeds are generally more effective than faster speeds, especially when using thin blades and making intricate cuts.
 - To find the best speed, start at a slow speed and gradually increase the speed until the optimum cutting rate is achieved.
12. This saw uses 5 inch long, plain end or pin type blades. See your Sears Catalog or Retail Store for accessory blades.
13. Blades wear faster when cutting plywood, which is very abrasive, when sawing wood which is thicker than the 3/4 inch, and when sawing hardwood, or when side pressure is placed on the blade.

MAKING INTERIOR SCROLL CUTS

1. One of the features of this saw is that it can be used to make scroll cuts on the interior of a board without breaking or cutting into the outline or perimeter of the board.

WARNING: To avoid injury from accidental starting, always turn switch "OFF" and lock switch before removing or replacing the blade.

2. To make interior cuts in a board, remove the scroll saw blade as explained in the Assembly section.
3. Drill a 1/4" hole in the board you will use to make interior cuts.
4. Place the board on the saw table with the hole in the board over the insert hole in the table.
5. Install blade through hole in board and adjust blade tension.
6. When finished making the interior scroll cuts, simply remove the blade from the blade holders, as described in the Assembly section, and remove the board from the table.

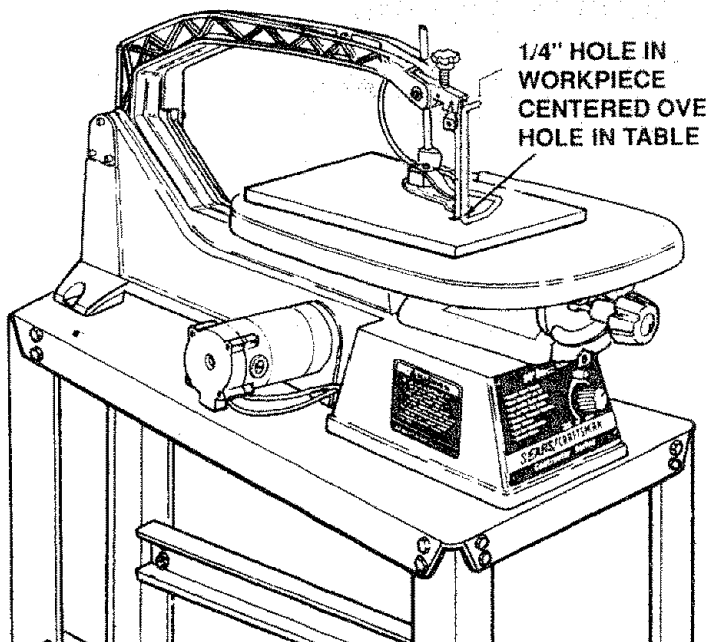

maintenance

WARNING: For your own safety, push control knob 'OFF' and remove plug from power source outlet before maintaining or lubricating your saw.

GENERAL

An occasional coat of past wax on the work table will allow the wood being cut to glide smoothly across the work surface.

MOTOR

If the power cord, motor cord or sensor cord, is worn, cut or damaged in any way, have it replaced immediately.

Do not attempt to oil the motor bearings or service the motor internal parts.

REPLACING MOTOR BRUSHES

The carbon brushes that come with this saw are designed to give long service life. When one of both brushes become shorter than 1/4", replace both brushes.

1. Remove the brush cap using a 1/4" flat blade screwdriver.

NOTE: The brushes are spring loaded and may push against the cap as it releases.

2. Install the new brush assembly and reinstall the brush cap.
3. Use the cap to push the spring and brass end of the assembly into the rectangular hole as the cap is tightened. Be sure that the brush cap is fully seated in the brush holder.
4. Repeat the procedure for the other brush.

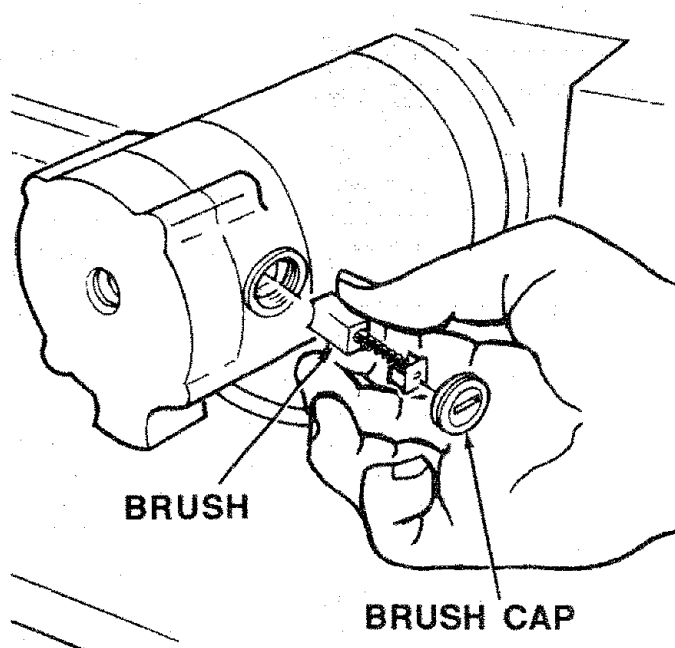

Sears recommends the following accessories

Item	Sears Number
Blades	See catalog for 5" long, plain end type and pin type blades

Sears may recommend other accessories not listed in the manual. See your nearest Sears store or Catalog department for other accessories.

Do not use any accessory unless you have received and read complete instructions for its use.

troubleshooting

WARNING: For your own safety, push control knob 'OFF' and remove plug from power source outlet before troubleshooting your scroll saw.

Problem	Probable Cause	Remedy Suggested
Breaking Blades	<ol style="list-style-type: none"> 1. Wrong tension. 2. Over working blade. 3. Wrong blade application. 4. Twisting blade in wood. 5. Using the wrong speed. 	<ol style="list-style-type: none"> 1. Adjust blade tension 2. Reduce feed rate. 3. Use narrow blades for cutting thin wood, wide blades for thicker wood. 4. Avoid side pressure on blade. Feed work slowly. 5. Use slower speeds for thin blades.
Motor will not run.	<ol style="list-style-type: none"> 1. Defective cord or plug. 2. Defective motor or control board. 	<ol style="list-style-type: none"> 1. Replace defective parts before using saw again. 2. Consult Sears Service. Any attempt to repair this control board or motor may create a HAZARD unless repair is done by a qualified service technician. Repair service is available at your nearest Sears Store.
Vibration/Noise NOTE: There will always be some vibration present when the saw is running because of reciprocating blade and arms.	<ol style="list-style-type: none"> 1. Improper mounting of saw. 2. Unsuitable mounting surface. 3. Loose table. 4. Loose motor mounting. 	<ol style="list-style-type: none"> 1. See mounting instructions in this manual for proper mounting technique. 2. The heavier your work bench is, the less vibration will occur. A plywood workbench will not be as good as the same size solid lumber. Use common sense in choosing a mounting surface. 3. Tighten table lock knob. 4. Tighten motor mounting screws.

wiring diagram

WARNING: To avoid electrocution or fire, repair electricals only with recommended service parts, and reassemble exactly as originally received when new.

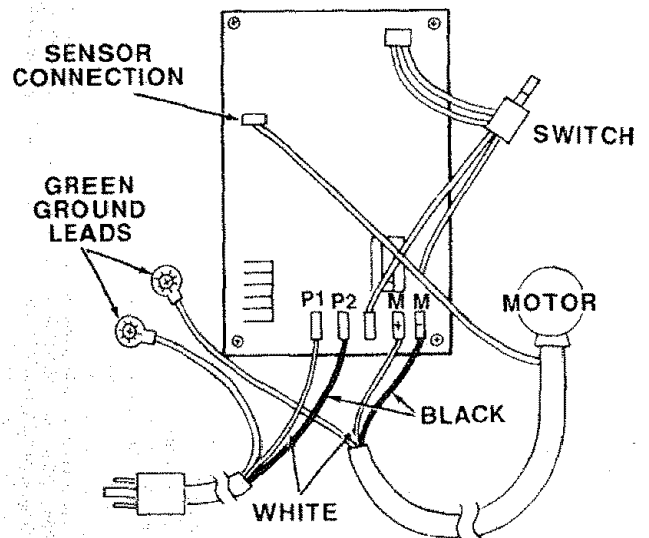

repair parts

PARTS LIST FOR CRAFTSMAN 20 INCH SCROLL SAW MODEL 113.236400

FIGURE 1

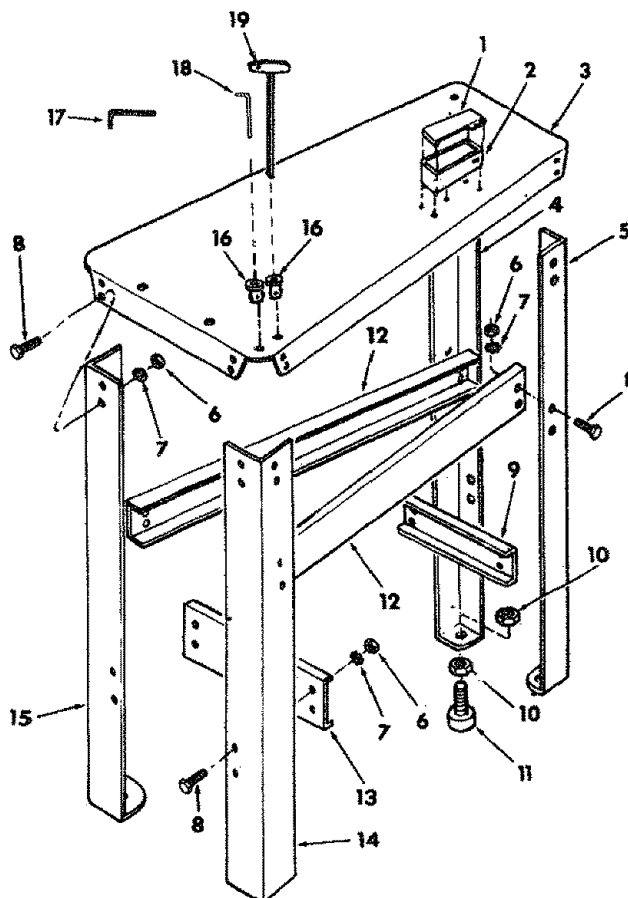

Key No.	Part No.	Description
1	820331	Lid, Blade Box
2	820332	Box, Blade
3	820366	Top, Stand
4	820481	Leg, Left Rear
5	820368	Leg, Right Rear
6	STD840812	* Nut, Hex M8 x 1.25
7	STD852008	* Lockwasher, M8
8	STD835016	* Screw, Hex Hd. M8 x 1.25-16
9	820371	Stiffener, Rear
10	STD541037	* Nut, Hex 3/8-16
11	803835-1	Foot, leveling
12	820369	Stiffener, Side
13	820370	Stiffener, Front
14	820487	Leg, Right Front
15	820367	Leg, Left Front
16	820410	Grommet
17	820336	Wrench, Hex 4mm
18	820733	Rod, Blade Change
19	820333	Wrench, "T" Handle

* Standard Hardware Item - may be purchased locally.

repair parts

PARTS LIST FOR CRAFTSMAN 20 INCH SCROLL SAW MODEL 113.236400

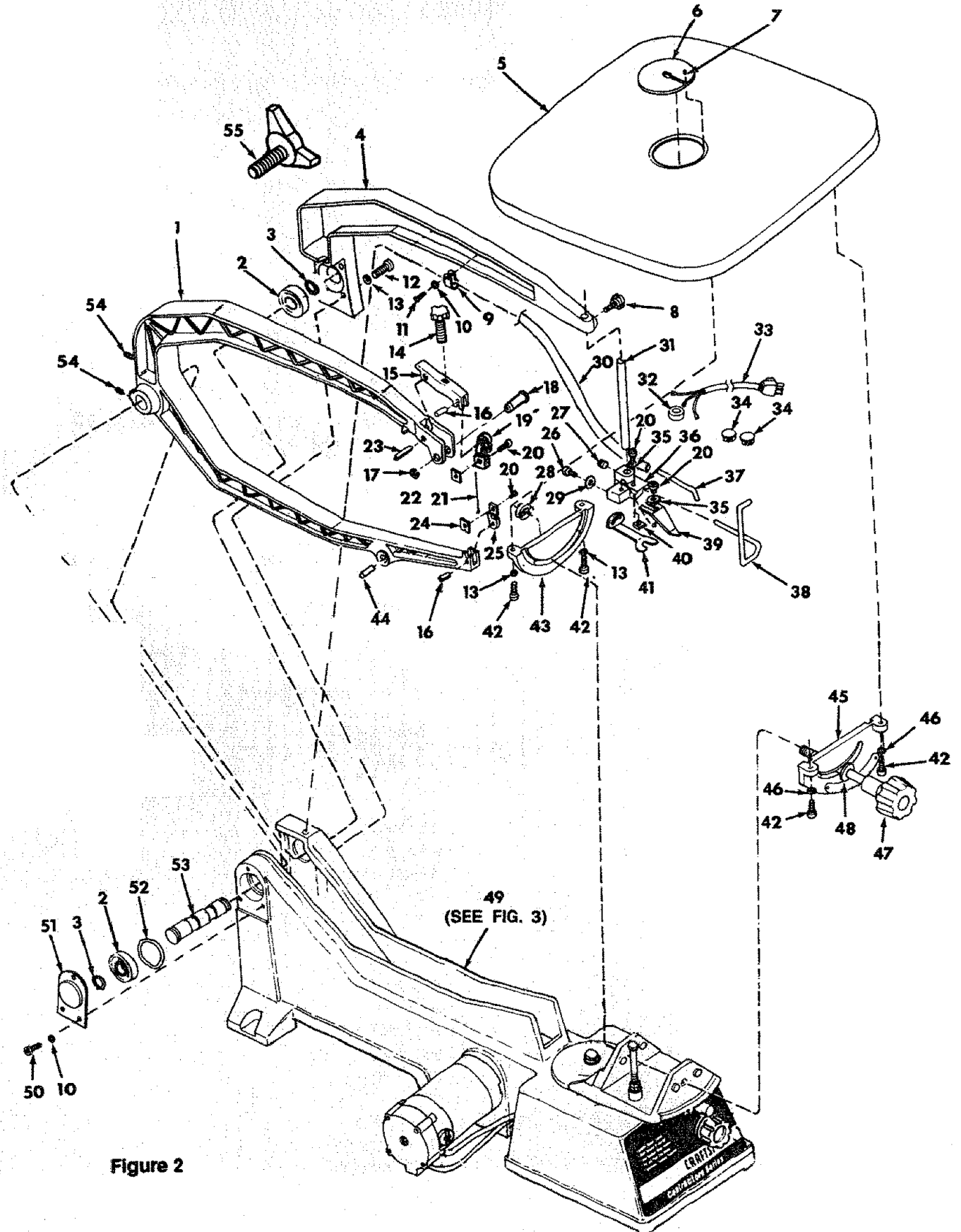

Figure 2

**PARTS LIST FOR CRAFTSMAN 20 INCH SCROLL SAW
MODEL 113.236400**

FIGURE 2

Key No.	Part No.	Description
1	820230	Arm, "C"
2	820394	Bearing, Tapered Roller
3	820242-2	Ring, Retaining 11-100
4	820349	Support, Arm
5	820298	Table
6	820299	Insert, Table
7	813249-27	Pin, Roll 2 x 6
8	820307	Knob, Holder
9	819246	Clamp, Cord
10	STD852004	* Lockwasher, M4
11	46-57436-3	* Screw, Pan Cross M4 x 0.7 x 6
12	820380	Screw, Soc. Cap M6 x 1.0 x 25
13	STD852006	* Lockwasher, M6
14	820305	Knob, Blade Tension
15	820304	Support, Blade Holder
16	813249-127	Pin, Roll 5 x 14
17	60044	Ring, Retaining
18	820773	Pin, Blade Tension
19	820315	Holder, Upper Blade
20	820379-1	Screw, Soc. Cap M5 x 0.8 x 8
21	9-26877	† Blade
22	820316	Clamp, Upper Blade
23	813249-131	Pin, Roll 5 x 25
24	820317	Clamp, Lower Blade
25	820314	Holder, Lower Blade
26	820379-2	Screw, Soc. Cap M5 x 0.8 x 16
27	820382	Screw, Soc. Set M8 x 1.25 x 8

Key No.	Part No.	Description
28	820408	Nut, M10 x 1.5 x 60
29	820237-4	Washer, M5 x 19 x 1.2
30	820330	Tubing, Plastic
31	820306	Shaft, Hold-Down
32	819293	Grommet
33	820323	Cord, Power
34	820483	Plug, Cap
35	STD851005	* Washer, M5 x 11.5 x 1.0
36	820301	Support, Hold-Down
37	820300	Nozzle
38	820352	Guard, Blade
39	820302	Guide, Blade
40	820420	Nut, Square M5 x 0.8
41	820303	Holder, Work
42	820380-2	Screw, Soc. Cap M6 x 1.0 x 18
43	820396	Trunnion, Rear
44	820409	Pin, Arm
45	820308	Trunnion, Front
46	STD852005	* Lockwasher, M10
47	820351	Knob, Table
48	820407	Washer, M10
49	820343	Base Assembly (See Figure 3)
50	820379	Screw, Soc. Cap M5 x 0.8-6
51	820297	Retainer, Bearing
52	814596-1	Washer, Spring
53	820318	Shaft, Arm
54	820245-1	Screw, Soc. Set M6 x 1.0 x 12
55	820334	Knob, Blade Change

* Standard Hardware Item - May be purchased locally.

† Stock Item - May be secured through the Hardware Department of most Sears Retail Stores or Catalog Order Houses.

repair parts

PARTS LIST FOR CRAFTSMAN 20 INCH SCROLL SAW MODEL 113.236400

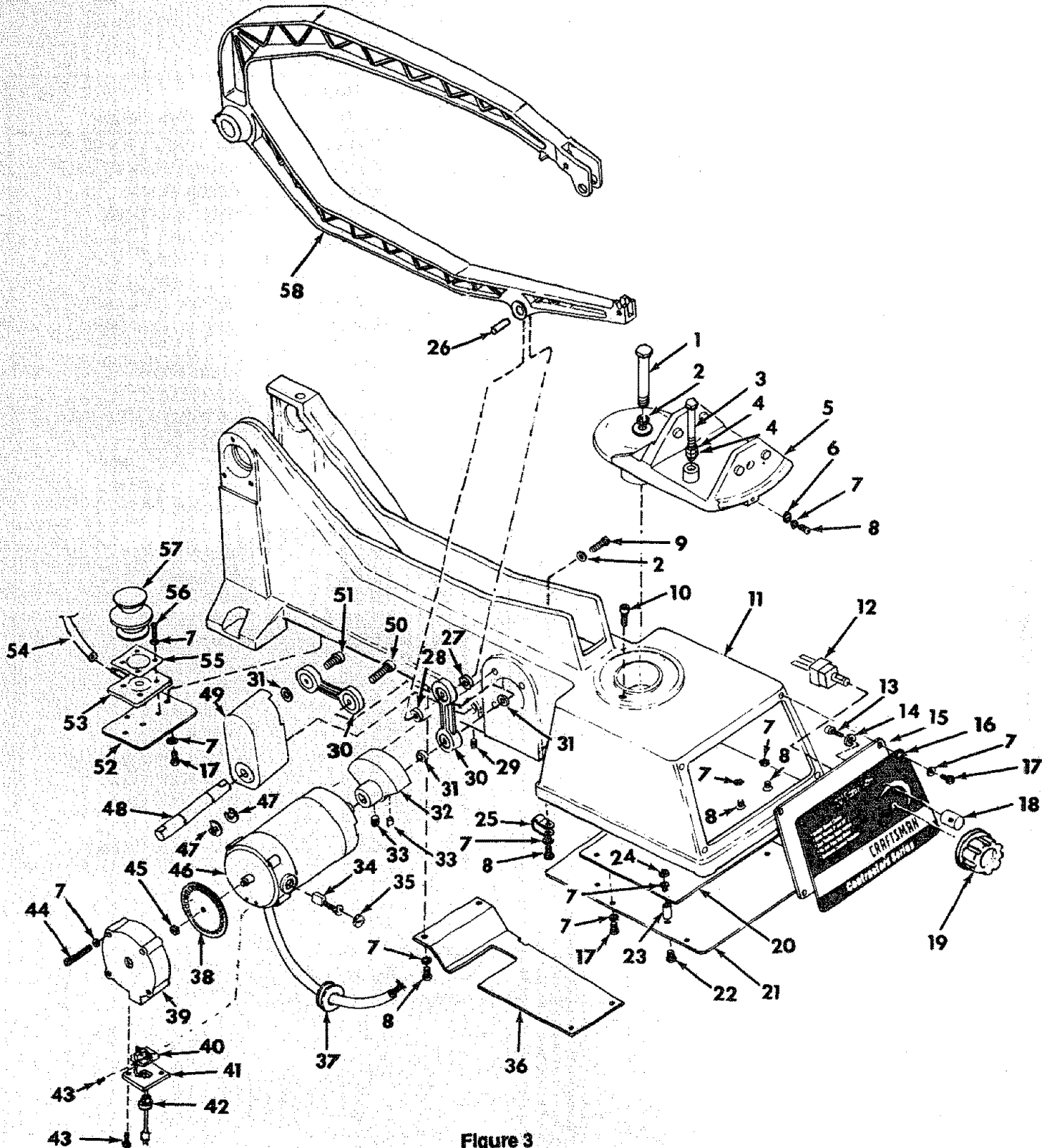

Figure 3

**PARTS LIST FOR CRAFTSMAN 20 INCH SCROLL SAW
MODEL 113.236400**

FIGURE 3

Key No.	Part No.	Description
1	820405	Bolt, Hex M10 x 1.5 x 60
2	STD852006	* Lockwasher, M6
3	STD835080	* Screw, Hex M8 x 1.25 x 80
4	STD840812	* Nut, Hex M8 x 1.25
5	820395	Support, Table
6	820309	Pointer, Bevel
7	STD852004	* Lockwasher, M4
8	46-57529-3	* Screw, Pan Cross M4 x 0.7 x 6
9	820249-3	Screw, Hex M6 x 1.0 x 25
10	820380-2	Screw, Soc. Cap M6 x 1.0 x 18
11	820343	Base
12	820774	Switch
13	820240-1	Screw, Pan Cr. M5 x 0.8 x 10
14	STD852005	* Lockwasher, M5
15	820363	Gasket, Foam
16	820362	Cover, Front
17	46-57436-3	* Screw, Pan Cr. M4 x 0.7 x 8
18	820335	Post, Lock
19	820365	Knob, Control
20	820361	Board, Control
21	820329	Cover, Electronics
22	816743-1	Screw, Pan Cr. M4 x 0.7 x 20
23	820422	Spacer, 4.5 x 8 x 14
24	STD840407	* Nut, Hex M4 x 0.7
25	820482	Clamp, Cord
26	820409	Pin, Arm (Reference, See Fig. 2)
27	820495	Spacer, Nylon 8 x 12 x 1
28	820495-1	Spacer, Nylon 8 x 12 x 4
29	820245-1	Screw, Soc. Set M6 x 1.0 x 12
30	820603	Link w/Bearings
31	820397-1	Spacer, 8 x 12 x 4

Key No.	Part No.	Description
32	820358	Counterbalance, Vertical
33	820245-2	Screw, Soc. Set M6 x 1.0 x 8
34	820322	Brush and Spring
35	820324	Cap, Brush
36	820428	Cover, Drive
37	819293	Grommet
38	820327	Disc, Encoder
39	820325	Cover, Encoder
40	820602	Board, Encoder
41	820357	Cover, Cord
42	169123-8	Relief, Strain
43	820401	Screw, Pan Hd. M3 x 0.5-6
44	46-57509-3	* Screw, Pan Hd M4 x 0.7-25
45	STD840610	Nut, M6 x 1.0
46	820353	Motor, Complete
47	805641-9	Ring, Retaining 11-420
48	820360	Shaft, Counterbalance
49	820604	Counterbalance, w/Bearings
50	820239-2	Screw, Soc. Cap M8 x 1.25 x 30
51	820239-1	Screw, Soc. Cap M8 x 1.25 x 20
52	820344	Mount, Pump
53	820345	Housing, Pump
54	820330	Tubing, Plastic (Reference, See Fig. 2)
55	820347	Retainer, Boot
56	46-57477-3	* Screw, Pan Cr. M4 x 0.7 x 12
57	820346	Boot, Pump
58	820230	Arm, "C" (Reference, See Fig. 2)
—	SP5498	Owner's Manual (Not Illus.)

Standard Hardware Item - May be purchased locally.

SEARS

owner's
manual

MODEL NO.
113.236400
SCROLL SAW
Variable Speed
With Stand

The model number of your
Scroll Saw will be found
attached at the rear of saw.

When requesting service or
ordering parts, always provide
the following information:

- Product Type
- Model Number
- Part Number
- Part Description

CONTRACTOR SERIES 20" VARIABLE SPEED SCROLL SAW

For the repair or replacement parts you need

Call 7 am - 7 pm, 7 days a week

1-800-366-PART

(1-800-366-7278)

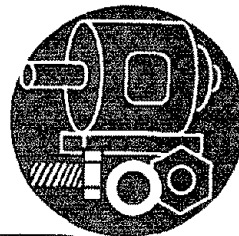

For in-home major brand repair service

Call 24 hours a day, 7 days a week

1-800-4-REPAIR

(1-800-473-7247)



For the location of a
Sears Repair Service Center in your area

Call 24 hours a day, 7 days a week

1-800-488-1222



For information on purchasing a Sears
Maintenance Agreement or to inquire
about an existing Agreement

Call 9 am - 5 pm, Monday-Saturday

1-800-827-6655



SEARS
REPAIR SERVICES

America's Repair Specialists

Sears Roebuck and Co., Hoffman Estates, IL. 60179 U.S.A.