

Save This Manual
For Future Reference

SEARS

*owners
manual*

**MODEL NO.
113.241680**

**SAW WITH LEGS
TWO TABLE EXTENSIONS
AND MOTOR**

Serial
Number _____

Model and serial
number may be found
at the rear of the base.

You should record both
model and serial number
in a safe place for
future use.

CAUTION:

**READ ALL
INSTRUCTIONS
CAREFULLY**

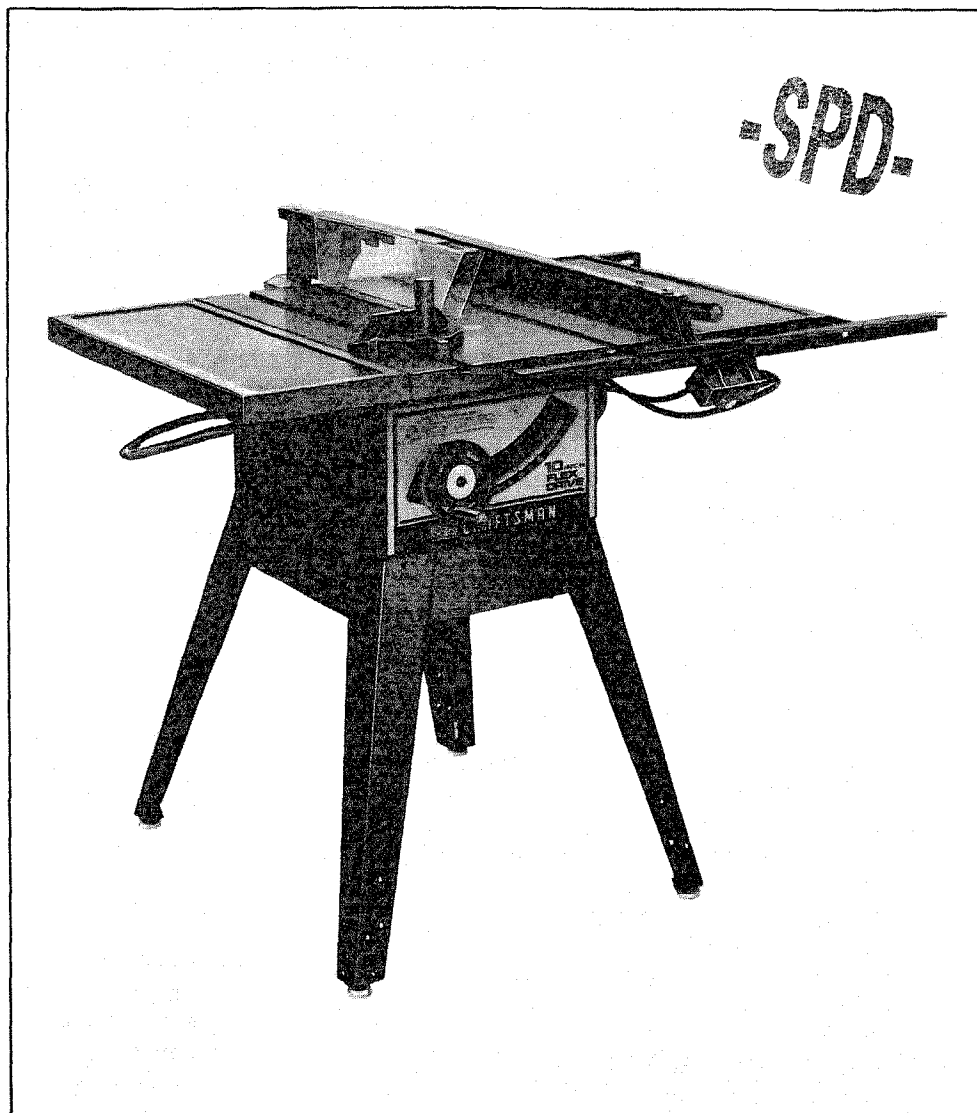

CRAFTSMAN

**10-INCH
FLEX DRIVE TABLE SAW**

- *assembly*
- *operating*
- *repair parts*

Sold by SEARS, ROEBUCK AND CO., Chicago, IL. 60684 U.S.A.

Part No. 62868

MAN1048485

Printed in U.S.A

FULL ONE YEAR WARRANTY ON CRAFTSMAN TABLE SAW

If within one year from the date of purchase, this Craftsman Table Saw fails due to a defect in material or workmanship, Sears will repair it, free of charge.

WARRANTY SERVICE IS AVAILABLE BY SIMPLY CONTACTING THE NEAREST SEARS SERVICE CENTER/DEPARTMENT THROUGHOUT THE UNITED STATES.

This warranty applies only while this product is in use in the United States.

This warranty gives you specific legal rights, and you may also have other rights which vary from state to state.

SEARS, ROEBUCK AND CO., Dept. 698/731A, Sears Tower, Chicago, IL 60684

GENERAL SAFETY INSTRUCTIONS FOR POWER TOOLS

1. KNOW YOUR POWER TOOL

Read and understand the owner's manual and labels affixed to the tool. Learn its application and limitations as well as the specific potential hazards peculiar to this tool.

2. GROUND ALL TOOLS

This tool is equipped with an approved 3-conductor cord and a 3-prong grounding type plug to fit the proper grounding type receptacle. The green conductor in the cord is the grounding wire. Never connect the green wire to a live terminal.

3. KEEP GUARDS IN PLACE

in working order, and in proper adjustment and alignment.

4. REMOVE ADJUSTING KEYS AND WRENCHES

Form habit of checking to see that keys and adjusting wrenches are removed from tool before turning it on.

5. KEEP WORK AREA CLEAN

Cluttered areas and benches invite accidents. Floor must not be slippery due to wax or sawdust.

6. AVOID DANGEROUS ENVIRONMENT

Don't use power tools in damp or wet locations or expose them to rain. Keep work area well lighted. Provide adequate surrounding work space.

7. KEEP CHILDREN AWAY

All visitors should be kept a safe distance from work area.

8. MAKE WORKSHOP CHILD-PROOF

— with padlocks, master switches, or by removing starter keys.

9. DON'T FORCE TOOL

It will do the job better and safer at the rate for which it was designed.

10. USE RIGHT TOOL

Don't force tool or attachment to do a job it was not designed for.

11. WEAR PROPER APPAREL

Do not wear loose clothing, gloves, neckties or jewelry (rings, wrist watches) to get caught in moving parts. Nonslip footwear is recommended. Wear protective hair covering to contain long hair. Roll long sleeves above the elbow.

12. USE SAFETY GOGGLES (Head Protection)

Wear Safety goggles (must comply with ANSI

Z87.1) at all times. Everyday eyeglasses only have impact resistant lenses, they are NOT safety glasses. Also, use face or dust mask if cutting operation is dusty, and ear protectors (plugs or muffs) during extended periods of operation.

13. SECURE WORK

Use clamps or a vise to hold work when practical. It's safer than using your hand, frees both hands to operate tool.

14. DON'T OVERREACH

Keep proper footing and balance at all times.

15. MAINTAIN TOOLS WITH CARE

Keep tools sharp and clean for best and safest performance. Follow instructions for lubricating and changing accessories.

16. DISCONNECT TOOLS

before servicing; when changing accessories such as blades, bits, cutters, etc.

17. AVOID ACCIDENTAL STARTING

Make sure switch is in "OFF" position before plugging in.

18. USE RECOMMENDED ACCESSORIES

Consult the owner's manual for recommended accessories. Follow the instructions that accompany the accessories. The use of improper accessories may cause hazards.

19. NEVER STAND ON TOOL

Serious injury could occur if the tool is tipped or if the cutting tool is accidentally contacted.

Do not store materials above or near the tool such that it is necessary to stand on the tool to reach them.

20. CHECK DAMAGED PARTS

Before further use of the tool, a guard or other part that is damaged should be carefully checked to ensure that it will operate properly and perform its intended function. Check for alignment of moving parts, binding of moving parts, breakage of parts, mounting, and any other conditions that may affect its operation. A guard or other part that is damaged should be properly repaired or replaced.

21. DIRECTION OF FEED

Feed work into a blade or cutter against the direction of rotation of the blade or cutter only.

22. NEVER LEAVE TOOL RUNNING UNATTENDED

Turn power off. Don't leave tool until it comes to a complete stop.

ADDITIONAL SAFETY INSTRUCTIONS FOR TABLE SAWS

WARNING: FOR YOUR OWN SAFETY, DO NOT OPERATE YOUR SAW UNTIL IT IS COMPLETELY ASSEMBLED AND INSTALLED ACCORDING TO THE INSTRUCTIONS ... AND UNTIL YOU HAVE READ AND UNDERSTAND THE FOLLOWING.

1. GENERAL SAFETY INSTRUCTIONS FOR POWER TOOLS ... SEE PAGE 2
2. GETTING TO KNOW YOUR SAW ... SEE PAGE 27.
3. BASIC SAW OPERATION ... SEE PAGE 30.
4. MAINTENANCE ... SEE PAGE 38.
5. STABILITY OF SAW

If there is any tendency for the saw to tip over or move during certain cutting operations such as cutting extremely large heavy panels or long heavy boards, the saw should be bolted down. If you attach any kind of table extensions over 24" wide to either end of the saw, make sure you either bolt the saw to the bench or floor as appropriate, or support the outer end of the extension from the bench or floor, as appropriate.

6. LOCATION

The saw should be positioned so neither the operator nor a casual observer is forced to stand in line with the saw blade.

7. KICKBACKS

A "KICKBACK" occurs during a rip-type operation when a part or all of the workpiece is thrown back violently toward the operator.

Keep your face and body to one side of the sawblade, out of line with a possible "Kickback." Kickbacks — and possible injury from them — can usually be avoided by:

- A. Maintaining the rip fence parallel to the sawblade.
- B. Keeping the sawblade sharp. Replace or sharpen antikickback pawls when points become dull.
- C. Keeping sawblade guard, spreader, and antikickback pawls in place and operating properly. The spreader must be in alignment with the sawblade and the pawls must stop a kickback once it has started. Check their action before ripping.
- D. NOT ripping work that is twisted or warped or does not have a straight edge to guide along the rip fence.
- E. NOT releasing work until you have pushed it all the way past the sawblade.
- F. Using a push stick for ripping widths of 2 to 6 in., and an auxiliary fence and push block for ripping widths narrower than 2 in. (See "Basic Saw Operation Using The Rip Fence" section.)
- G. NOT confining the cut-off piece when ripping or cross-cutting.
- H. When ripping apply the feed force to the section of the workpiece between the saw blade and the rip fence.

8. PROTECTION: EYES, HANDS, FACE, EARS, BODY

- A. If any part of your saw is malfunctioning, has been damaged or broken ... such as the motor switch, or other operating control, a safety device or the power cord ... cease

operating immediately until the particular part is properly repaired or replaced.

- B. Small loose pieces of wood or other objects that contact the rear of the revolving blade can be thrown back at the operator at excessive speed. This can usually be avoided by keeping the guard and spreader in place for all thru-sawing operations (sawing entirely thru the work) AND by removing all loose pieces from the table with a long stick of wood IMMEDIATELY after they are cut off.
- C. Use extra caution when the guard assembly is removed for resawing, dadoing, rabbeting, or molding — replace the guard as soon as that operation is completed.
- D. For rip or rip-type cuts, the following end of a workpiece to which a push stick or push board is applied must be square (perpendicular to the fence) in order that feed pressure applied to the workpiece by the push stick or block does not cause the workpiece to come away from the fence, and possibly cause a kickback.
- E. During rip and rip type cuts, the workpiece must be held down on the table and against the fence with a push stick, push block, or featherboards. A featherboard is made of solid lumber per sketch.

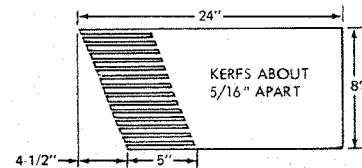

- F. NEVER turn the saw "ON" before clearing the table of all tools, wood scraps, etc., except the workpiece and related feed or support devices for the operation planned.
- G. NEVER place your face or body in line with the cutting tool.
- H. NEVER place your fingers or hands in the path of the sawblade or other cutting tool.
- I. NEVER reach in back of the cutting tool with either hand to hold down or support the workpiece, remove wood scraps, or for any other reason. Avoid awkward operations and hand positions where a sudden slip could cause fingers or hand to move into a sawblade or other cutting tool.
- J. DO NOT perform layout, assembly, or setup work on the table while the cutting tool is rotating.
- K. DO NOT perform any operation "FREEHAND" — always use either the rip fence or the miter gauge to position and guide the work.
- L. NEVER use the rip fence when crosscutting or the miter gauge when ripping. DO NOT use the rip fence as a length stop. Never hold onto or touch the "free end" of the workpiece or a "free piece" that is cut off, while power is "ON" and/or the sawblade is rotating.
- M. Shut "OFF" the saw and disconnect the power cord when removing the table insert, changing the cutting tool, removing or replacing the blade guard, or making adjustments.

N. Provide adequate support to the rear and sides of the saw table for wider or long workpieces.

O. Plastic and composition (like hardboard) materials may be cut on your saw. However, since these are usually quite hard and slippery, the antikickback pawls may not stop a kickback.

Therefore, be especially attentive to following proper set-up and cutting procedures for ripping. Do not stand, or permit anyone else to stand, in line with a potential kickback.

P. If you stall or jam the sawblade in the workpiece, turn saw "OFF", remove the workpiece from the sawblade and check to see if the sawblade is parallel to the miter gauge grooves and if the spreader is in proper alignment with the sawblade. If ripping at the time, check to see if the rip fence is parallel with the sawblade. Readjust as indicated.

Q. DO NOT remove small pieces of cut-off material that may become trapped inside the blade guard while the saw is running. This could endanger your hands or cause a kickback. Turn saw "OFF" and wait until blade stops.

R. Use extra care when ripping wood that has a twisted grain or is twisted or bowed — it may rock on the table and/or pinch the sawblade.

9. KNOW YOUR CUTTING TOOLS

A. Dull, gummy, or improperly sharpened or set cutting tools can cause material to stick, jam, stall the saw, or kickback at the operator. Minimize potential injury by proper cutting tool and machine maintenance.

NEVER ATTEMPT TO FREE A STALLED SAWBLADE WITHOUT FIRST TURNING THE SAW OFF.

B. Never use grinding wheels, abrasive cut-off wheels, friction wheels (metal slitting blades) wire wheels or buffing wheels.

10. USE ONLY ACCESSORIES DESIGNED FOR THIS SAW.

11. Crosscutting operations are more conveniently worked and with greater safety if an auxiliary wood facing is attached to the miter gauge using the holes provided. However, the facing must not interfere with the proper functioning of the sawblade guard.

12. Make sure the top of the arbor or cutting tool rotates toward you when standing in normal operating position. Also make sure the cutting tool, arbor collars and arbor nut are installed properly. Keep the cutting tool as low as possible for the operation being performed. Keep all guards in place whenever possible.

13. Do not use any blade or other cutting tool marked for an operating speed less than 3450 RPM. Never use a cutting tool larger in diameter than the diameter for which the saw was designed. For greatest safety and efficiency

when ripping, use the maximum diameter blade for which the saw is designed, since under these conditions the spreader is nearest the blade.

14. Adjust table inserts flush with the table top. NEVER operate the saw unless the proper insert is installed.

15. NEVER feed material into the cutting tool from the rear of the saw. An accident and serious injury could result.

17. NEVER use another person as a substitute for a table extension, or as additional support for a workpiece that is longer or wider than the basic saw table, or to assist in feeding or supporting or pulling the workpiece.

DO NOT pull the workpiece through the sawblade - position your body at the nose (in-feed) side of the guard: start and complete the cut from the same side. This will require added table support for long or wide workpieces that extend beyond the length or width of the saw table.

18. THINK SAFETY.

Safety is a combination of operator common sense and alertness at all times when the saw is being used.

19. NOTE AND FOLLOW SAFETY INSTRUCTIONS THAT APPEAR ON THE FRONT OF YOUR SAW.

DANGER FOR YOUR OWN SAFETY:

READ AND UNDERSTAND OWNERS MANUAL BEFORE OPERATING MACHINE.

1. WEAR SAFETY GOGGLES.
2. USE SAWBLADE GUARD FOR "THRU-SAWING."
3. KEEP HANDS OUT OF PATH OF SAWBLADE.
4. USE A "PUSH-STICK" WHEN REQUIRED.
5. KNOW HOW TO AVOID "KICKBACKS."
6. DO NOT PERFORM OPERATIONS "FREEHAND."
7. NEVER REACH AROUND OR OVER SAWBLADE.

WARNING: USE 120 VOLT, 15 AMP BRANCH CIRCUIT AND USE 15 AMP. TIME DELAY FUSE.

20. WARNING: DO NOT ALLOW FAMILIARITY (GAINED FROM FREQUENT USE OF YOUR SAW) TO BECOME COMMONPLACE. - ALWAYS REMEMBER THAT A CARELESS FRACTION OF A SECOND IS SUFFICIENT TO INFLICT SEVERE INJURY.

NOTE: Do not overtighten arbor nut. Use the arbor wrench to just "snug" it.



The operation of any power tool can result in foreign objects being thrown into the eyes, which can result in severe eye damage. Always wear safety goggles complying with ANSI Z87.1 (shown on Package) before commencing power tool operation. Safety Goggles are available at Sears retail or catalog stores.

MOTOR SPECIFICATIONS AND ELECTRICAL REQUIREMENTS

This saw is designed to use a 3450 RPM motor only. Do not use any motor that runs faster than 3450 RPM. It is wired for operation on 110-120 volts, 60 Hz., Alternating current. IT MUST NOT BE CONVERTED TO OPERATE ON 230 VOLTS.

The Black and Red motor leads are connected to quick connect tabs "A" and "B" on terminal board.

WARNING: Do not change any of these connections with current on.

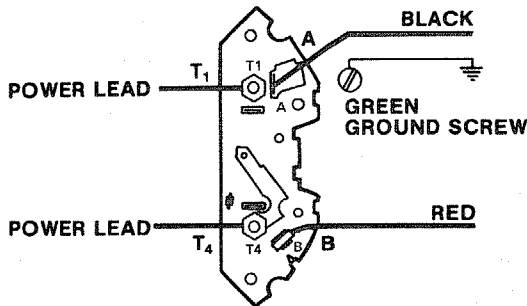

CAUTION: Do not use blower or washing machine motors or any motor with an automatic reset overload protector as their use may be hazardous. For replacement motor refer to parts list in this manual.

CONNECTING TO POWER SOURCE OUTLET

This saw must be grounded while in use to protect the operator from electrical shock.

If power cord is worn or cut, or damaged in any way, have it replaced immediately.

If your saw is for use on less than 150 volts it has a plug that looks like below.

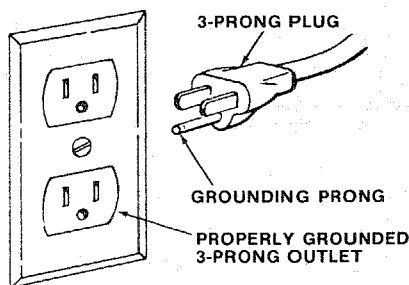

Plug power cord of fully assembled saw into 110-120V properly grounded type outlet protected by a 15-amp. time delay or Circuit-Saver fuse or circuit breaker.

IF YOU ARE NOT SURE THAT YOUR OUTLET IS PROPERLY GROUNDED, HAVE IT CHECKED BY A QUALIFIED ELECTRICIAN.

WARNING: DO NOT PERMIT FINGERS TO TOUCH THE TERMINALS OF PLUG WHEN INSTALLING OR REMOVING THE PLUG TO OR FROM THE OUTLET.

WARNING: IF NOT PROPERLY GROUNDED THIS POWER TOOL CAN INCUR THE POTENTIAL HAZARD OF ELECTRICAL SHOCK PARTICULARLY WHEN USED IN DAMP LOCATIONS, IN PROXIMITY TO PLUMBING, OR OUT OF DOORS. IF AN ELECTRICAL SHOCK OCCURS THERE IS THE POTENTIAL OF A SECONDARY HAZARD SUCH AS YOUR HANDS CONTACTING THE SAWBLADE.

This saw is equipped with a 3-conductor cord and grounding type plug which has a grounding prong, approved by Underwriters' Laboratories and the Canadian Standards Association. The ground conductor has a green lug and is attached to the tool housing at one end and to the ground prong in the attachment plug at the other end.

This plug requires a mating 3-conductor grounded type outlet as shown.

If the outlet you are planning to use for this saw is of the two prong type DO NOT REMOVE OR ALTER THE GROUNDING PRONG IN ANY MANNER. Use an adapter as shown and always connect the grounding lug to a known ground.

It is recommended that you have a qualified electrician replace the TWO prong outlet with a properly grounded THREE prong outlet.

An adapter as shown below is available for connecting plugs to 2-prong receptacles. The green grounding lug extending from the adapter must be connected to a permanent ground such as to a properly grounded outlet box.

An adapter as illustrated is available for connecting plugs to 2-prong receptacles.

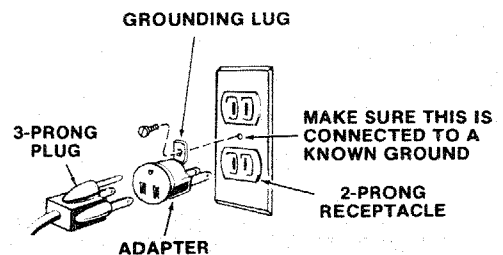

WARNING: THE GREEN GROUNDING LUG EXTENDING FROM THE ADAPTER MUST BE CONNECTED TO A PERMANENT GROUND SUCH AS TO A PROPERLY GROUNDED OUTLET BOX. NOT ALL OUTLET BOXES ARE PROPERLY GROUNDED.

If you are not sure that your outlet box is properly grounded, have it checked by a qualified electrician.

NOTE: The adapter illustrated is for use only if you already have a properly grounded 2-prong receptacle.

The use of any extension cord will cause some loss of power. To keep this to a minimum and to prevent over-heating and motor burn-out, use the table below to determine the minimum wire size (A.W.G.) extension cord. Use only 3 wire extension cords which have 3 prong grounding type plugs and 3-pole receptacles which will accept the plug on the saw.

The motor must rotate COUNTERCLOCKWISE when viewed from the shaft end.

1 H.P. MOTOR 110-120V	
Extension Cord Length	Wire Size A.W.G.
Up to 50 Ft.	14
50 to 100 Ft.	12
100 - 200 Ft.	10
200 - 400 Ft.	8

CONTENTS

<p>WARRANTY 2</p> <p>GENERAL SAFETY INSTRUCTION FOR POWER TOOLS 2</p> <p>ADDITIONAL SAFETY INSTRUCTIONS FOR TABLE SAWS 3</p> <p>MOTOR SPECIFICATIONS AND ELECTRICAL REQUIREMENTS 5</p> <p>UNPACKING AND CHECKING CONTENTS ... 6</p> <p>Tools Needed 6</p> <p>List of Loose Parts 7</p> <p>ASSEMBLY 8</p> <p>Assembling Steel Legs 8</p> <p>Mounting Saw 9</p> <p>Installing Handwheels 10</p> <p>Checking Table Insert 10</p> <p>Heeling Adjustment of Parallelism of Sawblade to Miter Gauge Groove 11</p> <p>Blade Tilt, or Squareness of Blade to Table 12</p> <p>Tilt Mechanism 14</p> <p>Mounting The Motor 14</p> <p>Mounting The Flexible Shaft 15</p> <p>Attaching Table Extensions 18</p> <p>Mounting Switch 19</p> <p>Installing Rip Fence Guide Bars 19</p> <p>Aligning Rip Fence 21</p> <p>Adjusting Rip Scale Indicator 23</p> <p>Installing Blade Guard 23</p> <p>Aligning Spreader 25</p> <p>Adjusting Miter Gauge 25</p> <p>Plugging in the Motor 26</p> <p>GETTING TO KNOW YOUR SAW 27</p> <p>On-Off Switch 27</p> <p>Elevation Handwheel 28</p>	<p>Tilt Handwheel 28</p> <p>Tilt Lock Handle 28</p> <p>Rip Fence 28</p> <p>Miter Gauge 28</p> <p>Blade Guard 28</p> <p>Table Insert 28</p> <p>Removing and Installing Sawblade 29</p> <p>Exacti-Cut 29</p> <p>BASIC SAW OPERATION USING THE MITER GAUGE</p> <p>Work Helpers 30</p> <p>Using the Miter Gauge 30</p> <p>Crosscutting 31</p> <p>Repetitive Cutting 31</p> <p>Miter Cutting 32</p> <p>Bevel Crosscutting 32</p> <p>Compound Miter Cutting 33</p> <p>BASIC SAW OPERATION USING THE RIP FENCE 33</p> <p>Ripping 33</p> <p>Bevel Ripping 33</p> <p>Ploughing and Molding 35</p> <p>Resawing 36</p> <p>Cutting Panels 36</p> <p>Rabbeting 36</p> <p>Dadoing 37</p> <p>Using Featherboards 37</p> <p>MOTOR 38</p> <p>MAINTENANCE 38</p> <p>LUBRICATION 39</p> <p>RECOMMENDED ACCESSORIES 39</p> <p>TROUBLE SHOOTING 40</p> <p>REPAIR PARTS 42</p>
---	--

UNPACKING AND CHECKING CONTENTS

TOOLS NEEDED

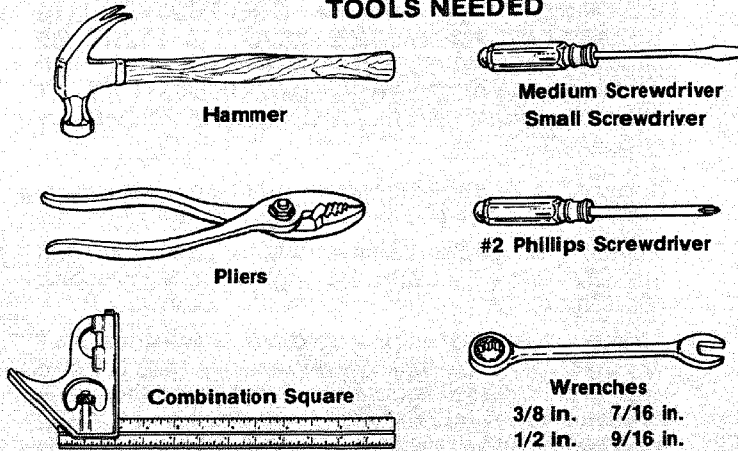

COMBINATION SQUARE MUST BE TRUE.

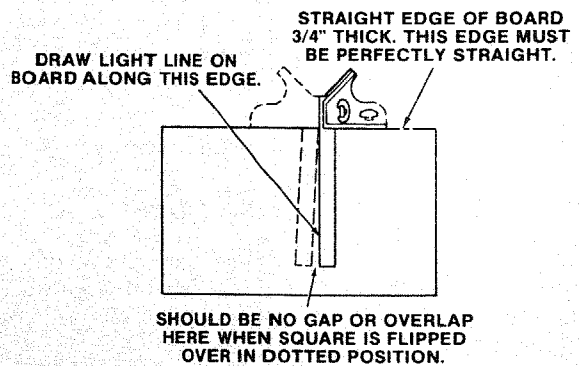

Model 113.241680 Table Saw is shipped complete in one carton and **INCLUDES** Two Table Extensions, Steel Legs, and Motor.

Separate all parts from packing materials and check each one with the illustration and the list of Loose Parts to make certain all items are accounted for, before discarding any packing material.

If any parts are missing, do not attempt to assemble the table saw, plug in the power cord or turn the switch on until the missing parts are obtained and are installed correctly.

Remove the protective oil that is applied to the table top and edges of the table. Use any ordinary household type grease and spot remover.

CAUTION: To avoid fire or health hazard never use gasoline, naphtha or similar highly volatile solvents.

Apply a coat of automobile wax to the table.

Wipe all parts thoroughly with a clean, dry cloth.

WARNING: FOR YOUR OWN SAFETY, NEVER CONNECT PLUG TO POWER SOURCE OUTLET UNTIL ALL ASSEMBLY STEPS ARE COMPLETE, AND YOU HAVE READ AND UNDERSTAND THE SAFETY AND OPERATIONAL INSTRUCTIONS.

LIST OF LOOSE PARTS

Item	Part Name	Qty.
A	Blade Guard and Spreader	1
B	Rip Fence	1
C	Owners Manual	1
D	Miter Gauge	1
E	Rod, Separation (Fence)	1
F	Leg	4
G	Stiffener, End	2
H	Stiffener, Side	2
J	Handwheel	2
K	Extension, 10 x 27	2
L	Motor	1
M	Motor Mount	1
N	Shaft, Flexible	1
O	Rip Fence Guide Bar with Rip Scale	1
P	Rip Fence Guide Bar, Rear	1
	Loose Parts Bag	1
	(Containing the Following Items):	
	Loose Parts Bag No. 62752	1
	Loose Parts Bag No. 62745	2
	Loose Parts Bag No. 62890	1
	Loose Parts Bag No. 62889	1
	Loose Parts Bag No. 62891	1
Q	Outlet, On/Off	1
R	Key, Switch	1
S	Wrench, Arbor	1
T	Bracket, Shaft	2
U	Support, Spreader	1

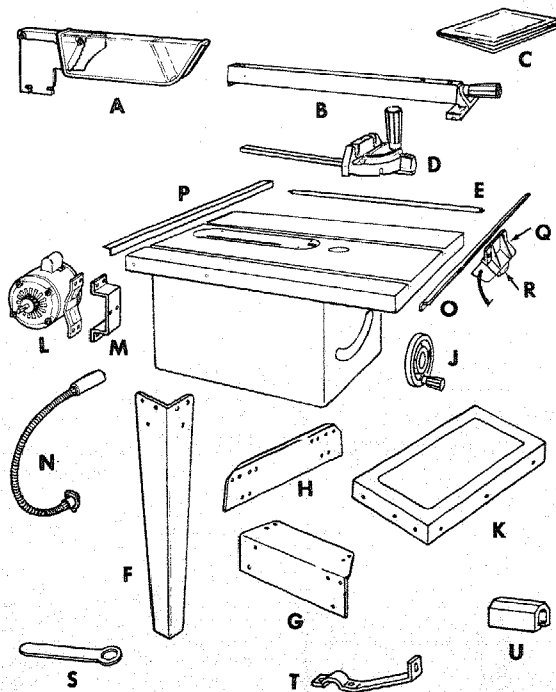

Item	Part Name	Qty.
	Loose Parts Bag No. 62745	2
	(Containing the Following Items):	
A	Bracket, Corner Support	2
B	Bracket, Corner Stiffener	2
	Loose Parts Bag No. 62837	1
	(Containing the Following Items):	
C	Screw, Truss Hd. 1/4-20 x 1	8
D	Lockwasher, External 1/4	8
D	Lockwasher, External 5/16	4
E	Nut, Hex 1/4-20	8
E	Nut, Hex 5/16-18	4
F	Screw, Hex Hd. 5/16-18 x 1-1/4	4
G	Washer, 11/32 x 11/16 x 1/16	4
G	Washer, 17/64 x 3/4 x 1/16	2
	Loose Parts Bag No. 62752 for Legs	1
	(Containing the Following Items):	
C	Screw, Truss Hd. 1/4-20 x 5/8	24
D	Lockwasher, External 1/4	24
D	Lockwasher, External 5/16	4
E	Nut, Hex 1/2-13	8
E	Nut, Hex 1/4-20	24
E	Nut, Hex 5/16-18	4
F	Screw, Hex 5/16-18 x 1-1/4	4
G	Washer, 11/32 x 11/16 x 1/16	8
H	Foot, Leveling	4
	Loose Parts Bag No. 62890	1
	(Containing the Following Items):	
D	Lockwasher, External #10	3
D	Lockwasher, External 1/4	6
D	Lockwasher, External 5/16	4
E	Nut, Hex 1/4-20	6
E	Nut, Hex 5/16-18	8
F	Screw, Hex Hd. 1/4-20 x 1	2
G	Washer, 21/64 x 5/8 x 1/16	2
G	Washer, 17/64 x 3/4 x 1/16	2
G	Washer, 21/64 x 47/64 x 1/16	4
J	Screw, Pan Hd. Type "T" 10-32 x 3/8	3
K	Bolt, Carriage 1/4-20 x 3/4	4
K	Bolt, Carriage 5/16-18 x 3/4	4

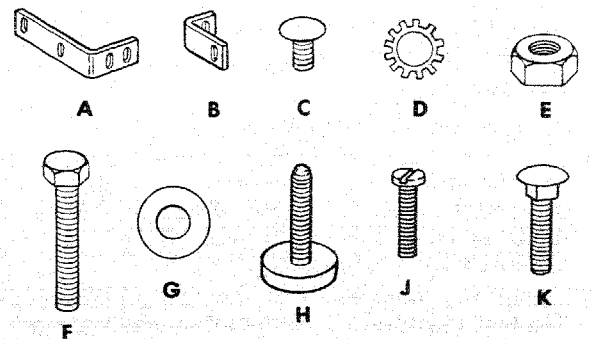

Item	Part Name	Qty.
	Loose Parts Bag No. 62889	1
	(Containing the Following Items):	
A	Nut, Weld	1
B	Clamp, Spreader	1
C	Bracket, Spreader	1
D	Lockwasher, External 1/4	4
D	Lockwasher, External #10	2
D	Lockwasher, External 5/16	5
E	Wrench, Hex "L" 3/32	1
E	Wrench, Hex "L" 1/8	1
E	Wrench, Hex "L" 5/32	1
F	Tie Wire	2
G	Spacer, Fence Guide Bar	2
H	Nut, Self-Threading	2
J	Connector, Motor	1

Item	Part Name	Qty.
	Loose Parts Bag No. 62891	1
	(Containing the Following Items):	
A	Bolt, Carriage 1/4-20 x 3/4	4
B	Screw, Soc. Set 1/4-20 x 1	2
C	Washer, 17/64 x 5/8 x 1/32	4
D	Nut, Hex 1/4-20	4
E	Nut, Wing 1/4-20	2
F	Screw, Hex Hd. 5/16-18 x 1-3/4	2
F	Screw, Hex Hd. 5/16-18 x 3/4	1
F	Screw, Hex Hd. 5/16-18 x 1	2
G	Screw, Pan Hd. 10-32 x 3/4	2
H	Key, Sq. 3/16	1

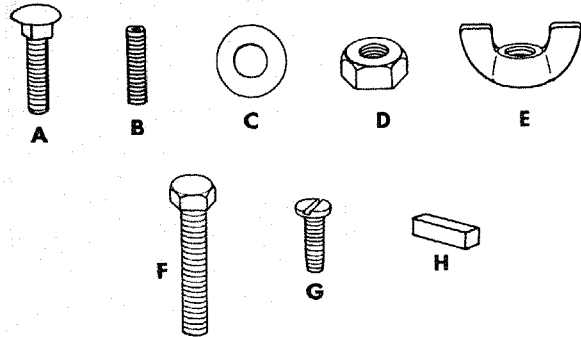
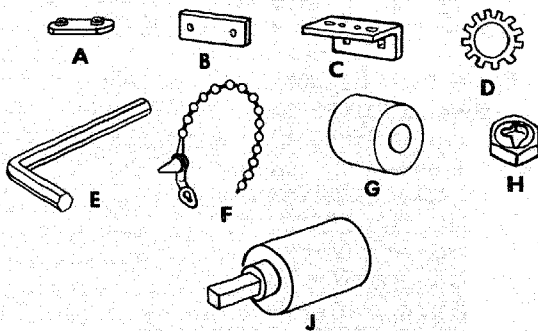

ASSEMBLY

ASSEMBLING STEEL LEGS

NOTE: Steel Legs are furnished with Model 113.241680. From among the loose parts, find the following Hardware:

- 24 Truss Head Screws, 1/4 - 20 x 5/8 in. long (top of screw is rounded)
- 24 Lockwashers, 1/4 in. External Type (approx. dia. of hole 1/4 in.)
- 24 Hex Nuts, 1/4 - 20 (approx. dia. of hole 1/4 in.)
- 8 Hex Nuts, 1/2 - 13 (approx. dia. of hole 1/2 in.)
- 4 Leveling feet.

Assemble the legs as shown . . .

1. Insert the Truss Head Screws through the holes in the legs, then through the holes in the stiffeners. **MAKE SURE THE SCREWS GO THROUGH THE HOLES IN THE SIDE STIFFENERS MARKED "X"**.
2. Install the lockwashers . . . screw on the nuts but **Do Not** tighten until completely assembled.
3. Install leveling feet.

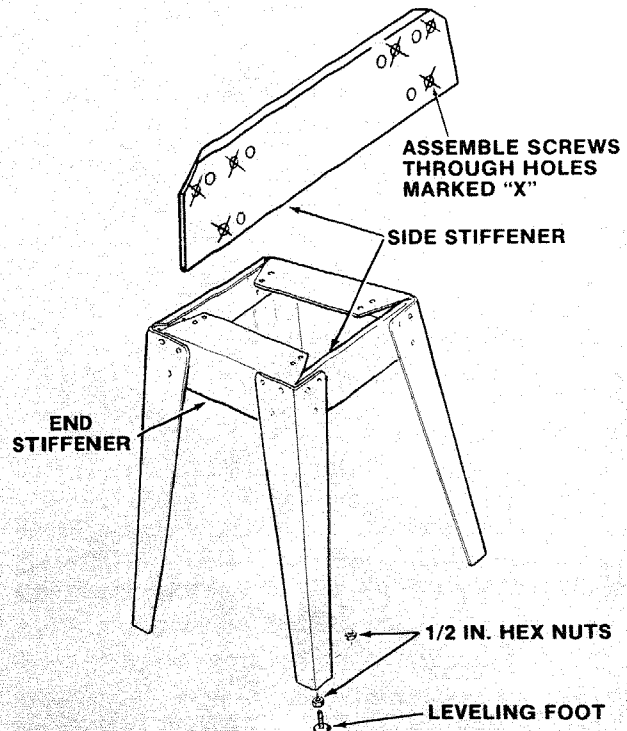

MOUNTING SAW

- From among the loose parts, find the following hardware:
 - 4 Hex Head Screws, 5/16 - 18 x 1-1/4 in. long.
 - 4 Hex Nuts, 5/16 - 18 (approx. dia. of hole 5/16 in.)
 - 4 Lockwashers, 5/16 in. External Type (approx. dia. of hole, 5/16 in.)
 - 8 Flat Washers, (dia. of hole 11/32 in.)
- Place saw on legs so that holes in bottom of saw line up with holes in top of legs.

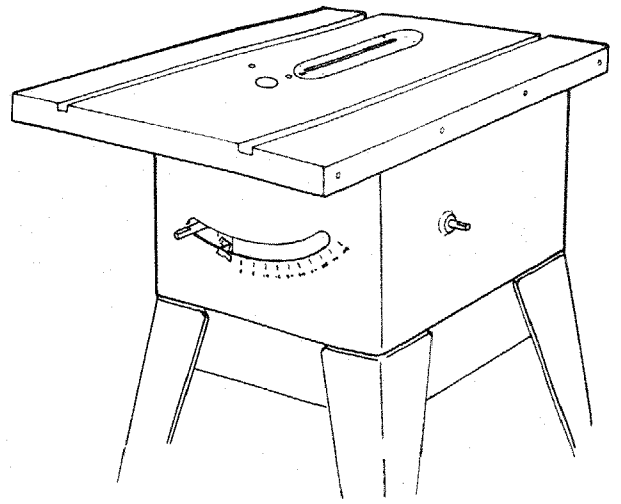

- Install screws, washers, lockwashers and nuts as shown.

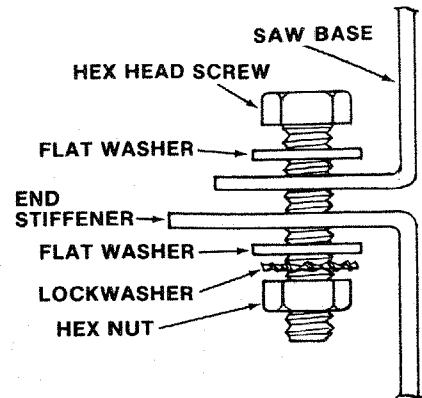

If you mount the saw on any other bench, make sure that there is an opening in the top of the bench the same size as the opening in the bottom of the saw so that the sawdust can drop through. Recommended working height is 33 to 37 inches from the top of the saw table to the floor.

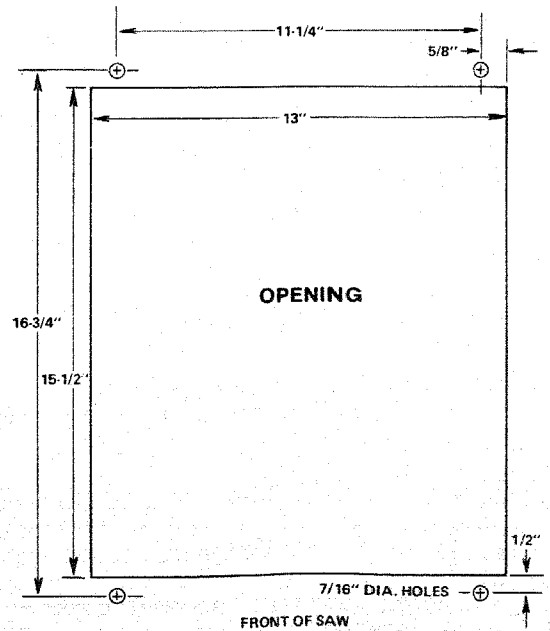

IMPORTANT — Read Before Proceeding

Blade *cannot* be more than 2 inches above the table top when tilting the sawblade to make bevel cuts or adjustments. Lower blade to 2 inches or closer to the table top to tilt the saw. Failure to do this may result in damage to your saw.

INSTALLING HANDWHEELS

Line up FLAT SPOTS on shaft and handwheel, push handwheel onto shaft. Install screw and lockwasher to lock handwheels on shaft.

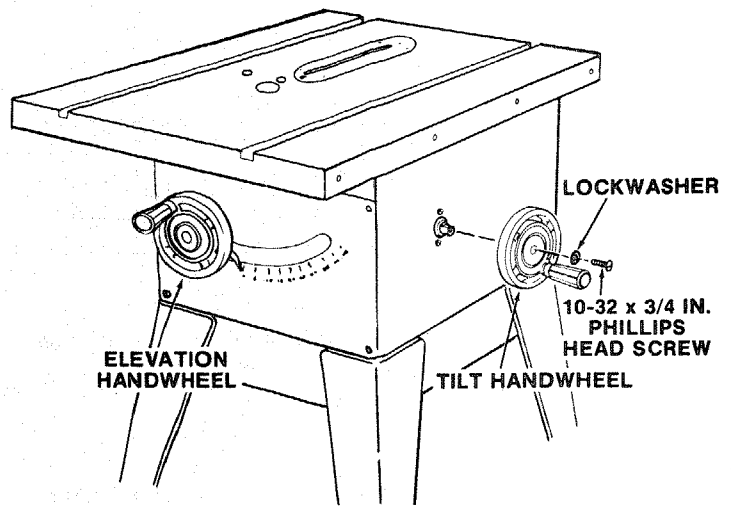

CHECKING TABLE INSERT

1. Insert should be even with table top. Check as shown. Loosen flat head screw that holds insert and adjust the four set screws as necessary. Tighten flat head screw. Do not tighten screw to the point where it deflects the insert.

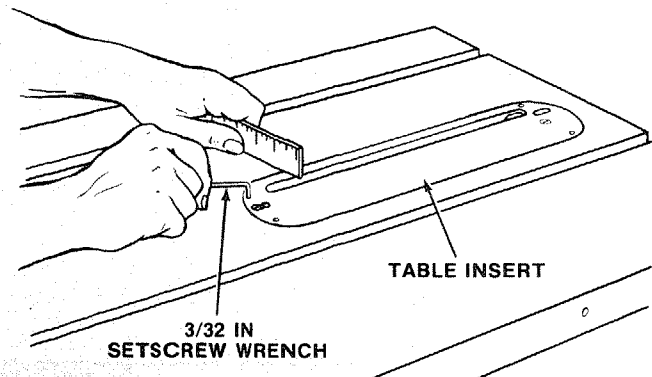

2. To remove insert.
 - A. Loosen Phillips Flat Head Screw.
 - B. Lift insert from front end, and pull toward front of saw.
3. To replace insert.

Place insert into insert opening in table and push toward rear of saw to engage spring clip and until keyslot in insert will drop over screw. Tighten screw.
Do not tighten screw to the point where it will deflect the insert.

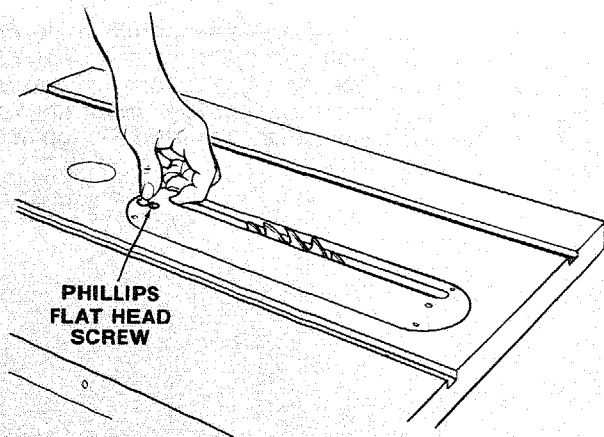

HEELING ADJUSTMENT or PARALLELISM OF SAWBLADE TO MITER GAUGE GROOVE

While cutting, the material must move in a straight line PARALLEL to the SAWBLADE . . . therefore both the miter gauge GROOVE and the RIP FENCE must be PARALLEL to the SAWBLADE.

If the sawblade IS NOT parallel to the miter gauge groove, the blade will bind at one end of the cut. (This is known as "HEELING").

To check for parallelism:

WARNING — TO AVOID INJURY FROM ACCIDENTAL START, TURN SWITCH "OFF" AND REMOVE PLUG FROM POWER SOURCE OUTLET.

1. Raise blade all the way up by turning elevation handwheel clockwise.
2. Mark an "x" on one of the teeth which is SET (bent) to the LEFT.
3. Place the head of a combination square in the GROOVE . . . adjust blade of square so that it just touches the tip of the MARKED tooth.

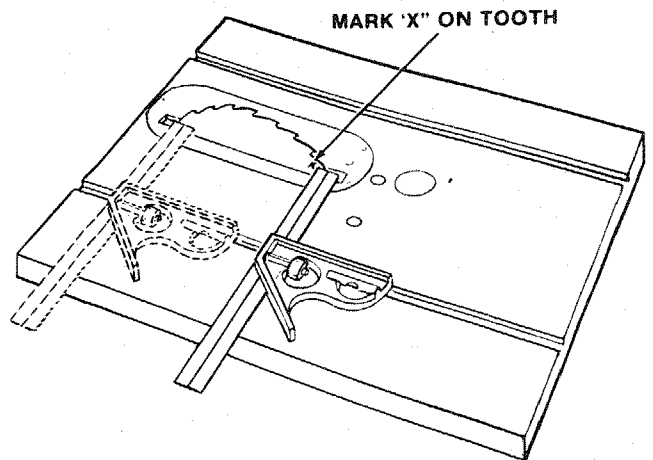

4. Move square to REAR, rotate blade to see if MARKED tooth again touches blade of square.
5. If tooth touches square at FRONT and REAR . . . sawblade is PARALLEL to MITER GAUGE GROOVE.

6. If tooth does not touch the same amount . . . the mechanism underneath must be adjusted to make the blade PARALLEL to GROOVE.
 - A. Rear support bearing must be moved TOWARD the combination square if there is a space between marked tooth and end of square in step 4.
 - B. Rear support bearing must be moved AWAY from the square if marked tooth pushes square out of position in the groove.

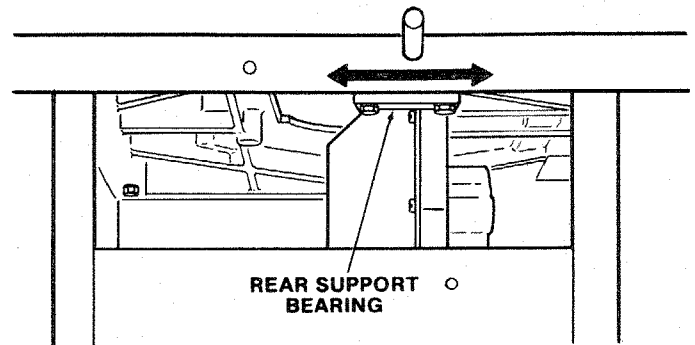

7. Make sure tilt clamp screw is tightened.

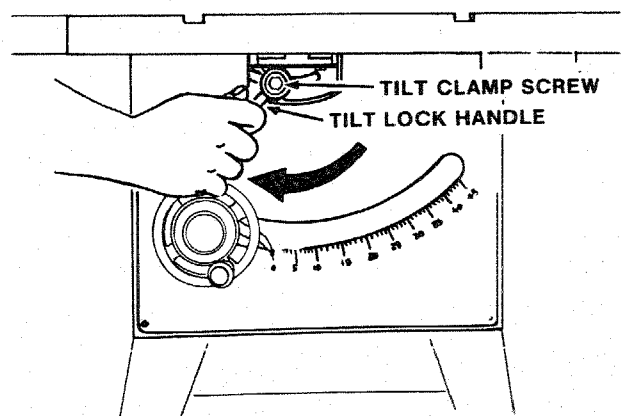

8. Loosen both screws that hold the rear support bearing and both screws that hold the front support bearing.

NOTE: Rear screws can be reached through back of saw. Use a 9/16-in. wrench. To reach front support bearing screws insert open end wrench through opening in front of base by the tilt clamp screw.

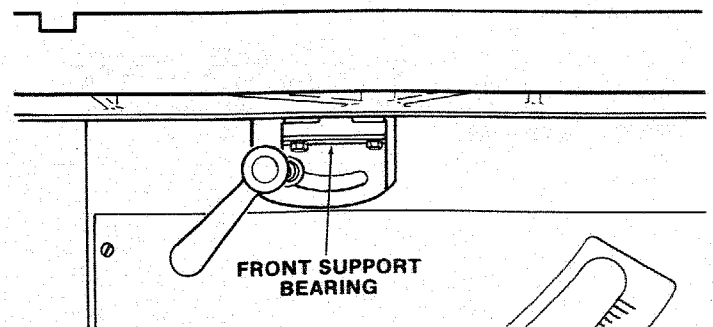

9. Using a wood block and hammer as shown, move rear support bearing to right or left as required to realign the blade. If necessary, shift front support bearing in similar manner; but do NOT move front support bearing unless necessary. Recheck the alignment with the square, then securely retighten all support bearing screws.

NOTE: Be certain that the widest blade you use does not contact blade insert after moving support bearing. Check this at both 0° (perpendicular to the table) and 45° bevel by rotating the fully elevated blade by hand. Readjust as required to maintain sufficient clearance.

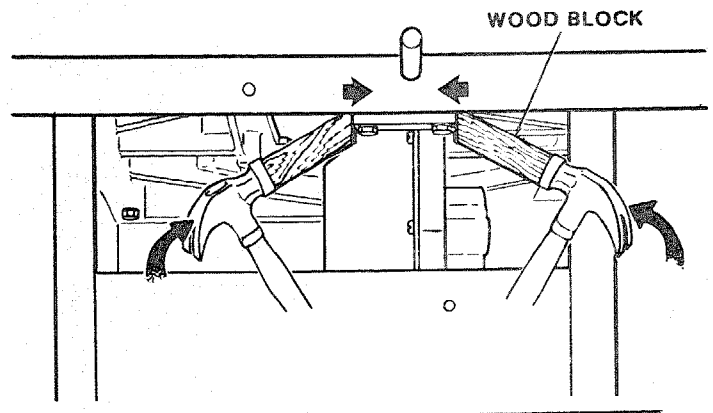

BLADE TILT, OR SQUARENESS OF BLADE TO TABLE

90° (SQUARE) and 45° (BEVEL) STOP SCREWS.
When the bevel pointer is pointing directly to the "0" mark on the bevel scale, the sawblade should make a SQUARE cut 90° to the table.

To check for SQUARENESS:

WARNING: TO AVOID INJURY FROM ACCIDENTAL START, TURN SWITCH "OFF" AND REMOVE PLUG FROM POWER SOURCE OUTLET.

1. Blade should be all the way UP.
2. Place the square against blade. Make sure square is not touching the TIP of one of the saw TEETH.

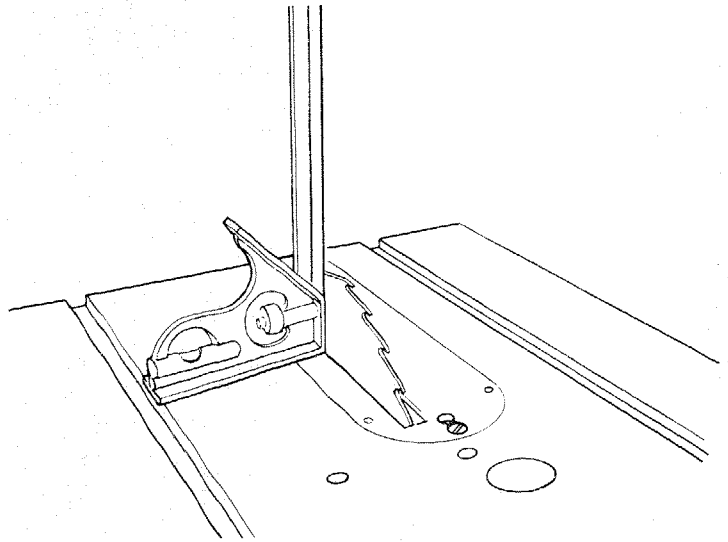

3. Turn the tilt-lock handle (COUNTER-CLOCKWISE) to loosen the tilt clamp screw.
4. **NOTE:** Handle is spring loaded for engagement with screw head — must be pushed inward for disengagement whenever necessary to obtain a new grip on screw head.

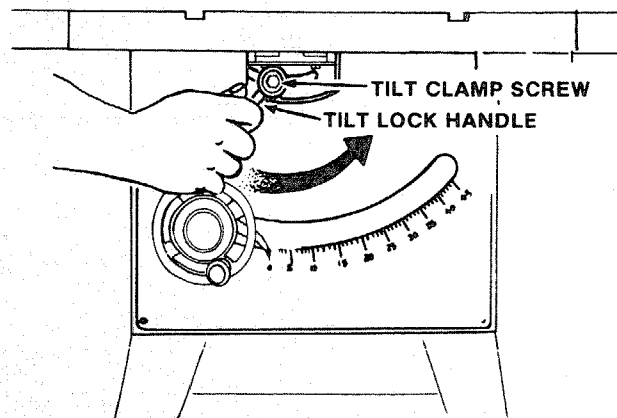

NOTE: You do not have to lower the blade elevation to complete this step because tilt wheel is moved very little.

5. Rotate TILT handwheel CLOCKWISE one turn to tilt blade. Now rotate handwheel COUNTER-CLOCKWISE until it stops. Blade should now be square with table.

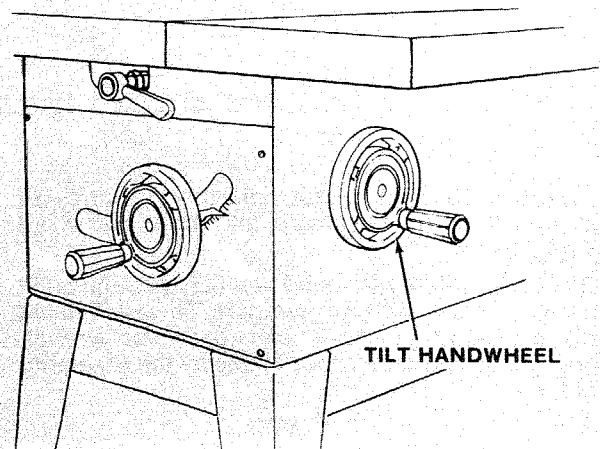

If blade is NOT SQUARE to table . . . the 90° stop screw must be ADJUSTED.

- A. Unscrew 90° STOP SCREW three to four turns using 3/16 in. setscrew wrench.
- B. Turn tilt handwheel clockwise one turn, then turn handwheel counterclockwise until blade is square with table.
- C. Screw 90° stop screw IN until it stops . . . check once again for squareness and readjust screw, if necessary.

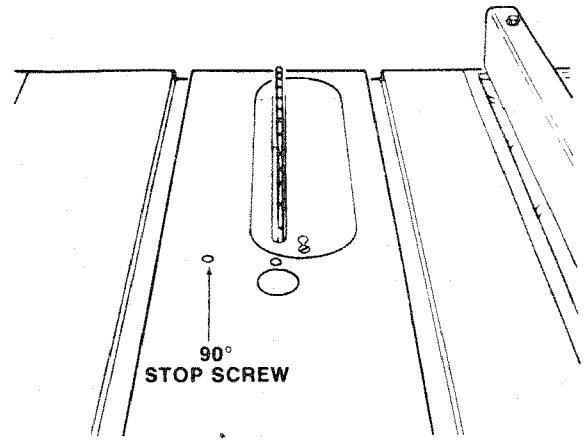

If blade is SQUARE to table;

- A. Check pointer
IF POINTER DOES NOT point to the "0" mark on the bevel scale;
- A. Remove Elevation Handwheel.
- B. Loosen pointer screw and adjust pointer using medium screwdriver.
- C. Reinstall Elevation Handwheel.

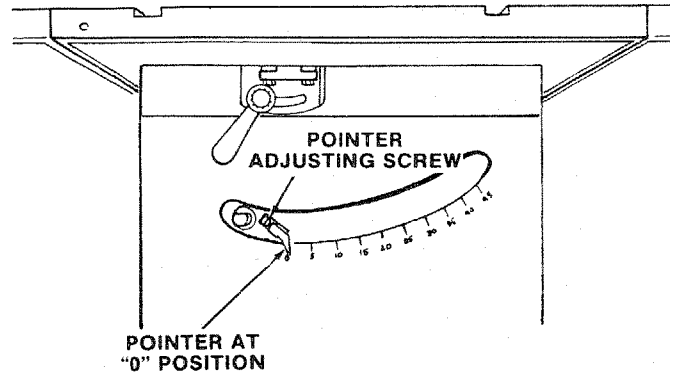

NOTE: Lower sawblade elevation before tilting sawblade. Failure to do this may result in damage to your saw.

1. Lower the blade to about two inches above the table.
2. Turn tilt handwheel counterclockwise to tilt blade to a 45° bevel.
3. Raise blade elevation to maximum height.
4. Check bevel of blade with the head of the combination square.

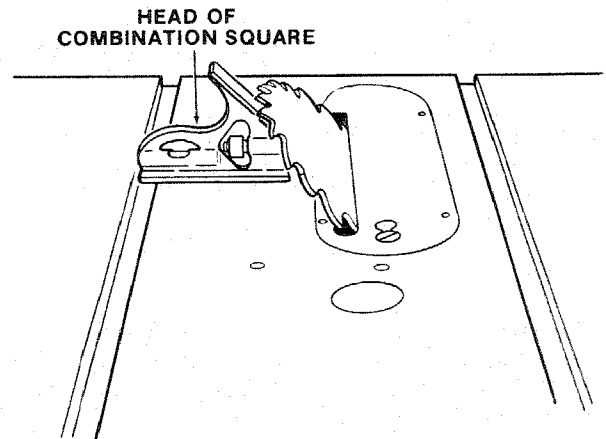

If blade is NOT 45° to table . . . the 45° stop screw must be ADJUSTED.

- A. Unscrew 45° STOP SCREW three to four turns using 3/16 in. setscrew wrench.
- B. Turn tilt handwheel until blade is 45° to the table.
- C. Screw 45° stop screw IN until it stops . . . check once again and readjust screw, if necessary.
5. Lower blade.
6. Tilt blade back to 90°.
7. Tighten tilt lock handle.
8. Lower blade below table.

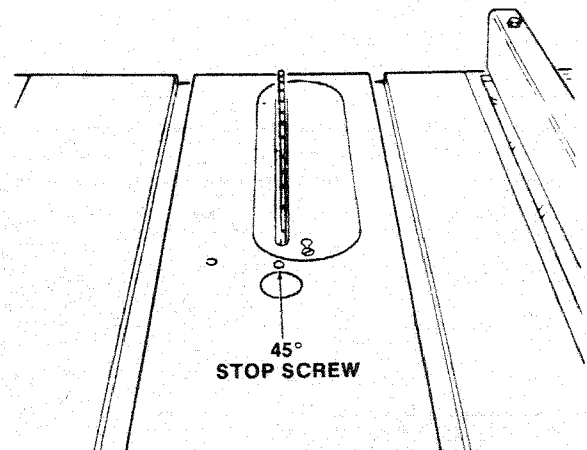

TILT MECHANISM

Lower blade to 2 inches or closer to the table top before tilting blade. Failure to do this may result in damage to your saw.

The handwheel should turn freely without binding. The turning action can be adjusted by tightening or loosening the screws in the bearing retainer.

NOTE: Tilt Handwheel must be removed to adjust. When adjusting the screws in the bearing retainer using a screwdriver, hold the nut inside using a 3/8 in. wrench.

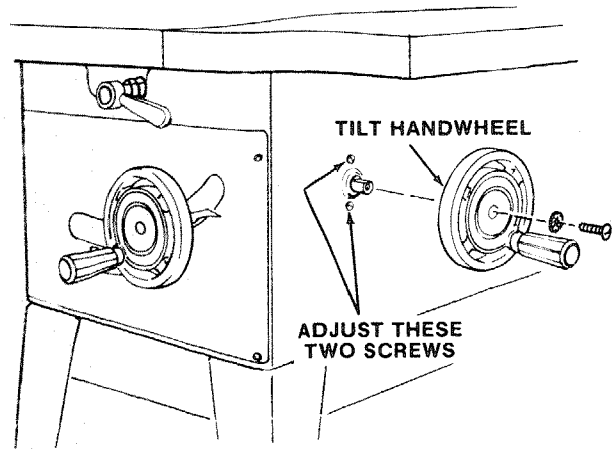

MOUNTING THE MOTOR

NOTE: Motor is included with Model 113.241680. This motor is non-reversible.

1. CHECK MOTOR ROTATION

- The motor must rotate **COUNTER-CLOCKWISE** when viewed from the shaftend.
- MAKE SURE "KEY" IS REMOVED FROM SHAFT.**
- Place the motor on your workbench or on the floor.
- Plug the cord into a properly grounded outlet (See "Motor Specifications and Electrical Requirements" Section.) Notice the rotation of the shaft. If it is **not** rotating **COUNTERCLOCKWISE**, do not continue assembly. Contact your nearest Sears Store or Service Center.
- Remove plug from outlet.

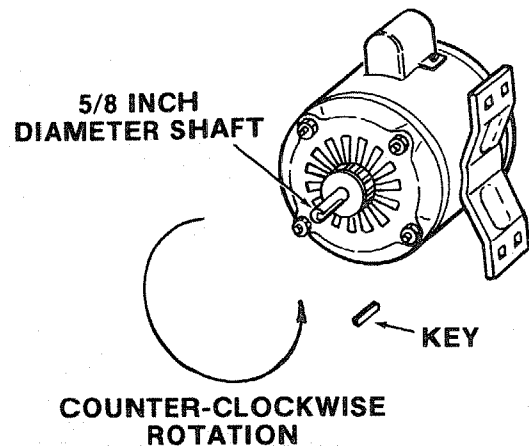

WARNING: TO AVOID INJURY FROM ACCIDENTAL START, MAKE SURE MOTOR IS NOT PLUGGED INTO SWITCH OR ANY OTHER ELECTRICAL OUTLET.

- From among the loose parts find the following:
 - 1 Motor Mount
 - 2 Carriage Bolts 1/4-20 x 3/4 in. long
 - 2 Hex Nuts 1/4-20 (approx. dia. of hole 1/4 in.)
 - 2 Lockwashers External Type 1/4 in. (approx. dia. of hole 1/4 in.)
- Insert carriage bolts through square holes in rear panel of table saw and through square holes in motor mount. Install lockwashers and hex nuts.
- Tighten nuts.

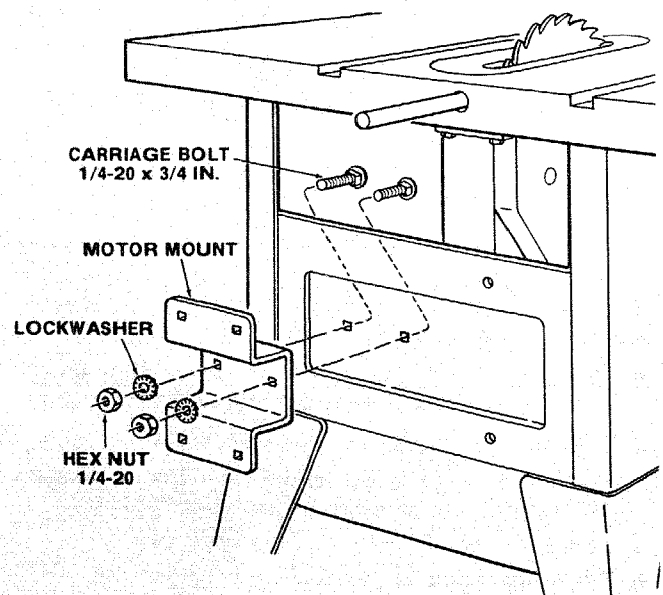

5. From among the loose parts, find the following hardware:
 - 4 Carriage Bolts, 5/16 - 18 x 3/4 in. long
 - 4 Flatwashers 17/64 x 3/4 x 1/16
 - 4 Hex. Nuts, 5/16 - 18 (approx. dia. of hole 5/16 in.)
 - 4 Lockwashers, 5/16 in. External Type (approx. dia. of hole 5/16 in.)
6. Place motor on MOTOR MOUNT . . . insert bolts through holes in MOUNT then through the motor. Install lockwashers, and hex. nuts. Do not tighten.
7. Position MOTOR BASE on MOTOR MOUNT so the edges of the MOTOR BASE and the MOTOR MOUNT are even. Tighten all 4 Hex. nuts securely.

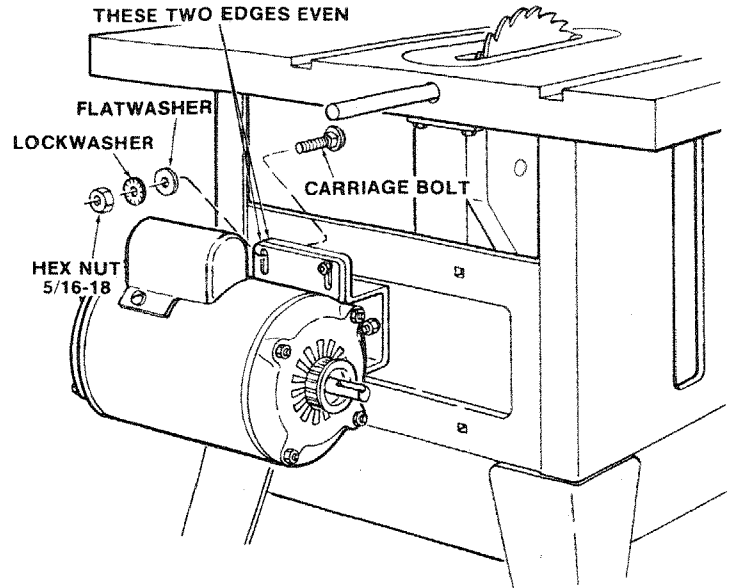

MOUNTING THE FLEXIBLE SHAFT

1. From among the loose parts find the following:
 - 3 Pan Head Screws 8-32 x 3/8 in. long
 - 3 Lockwashers External Type No. 8
 - 2 Carriage Bolts 1/4 - 20 x 3/4 in. long
 - 2 Hex Head Screws 1/4-20 x 1 in. long
 - 4 Hex Nuts 1/4-20 (approx. dia. of hole 1/4 in.)
 - 2 Washers 17/64 x 3/4 x 1/16
 - 4 Lockwashers External Type 1/4 in. (approx. dia. of hole 1/4 in.)
 - 2 Shaft Brackets
 - 1 Flexible Shaft Assembly
 - 1 Motor Connector
 - 1 Square Key 3/16 x 15/16 long
2. Install 3/16 in. square key in motor shaft keyway.

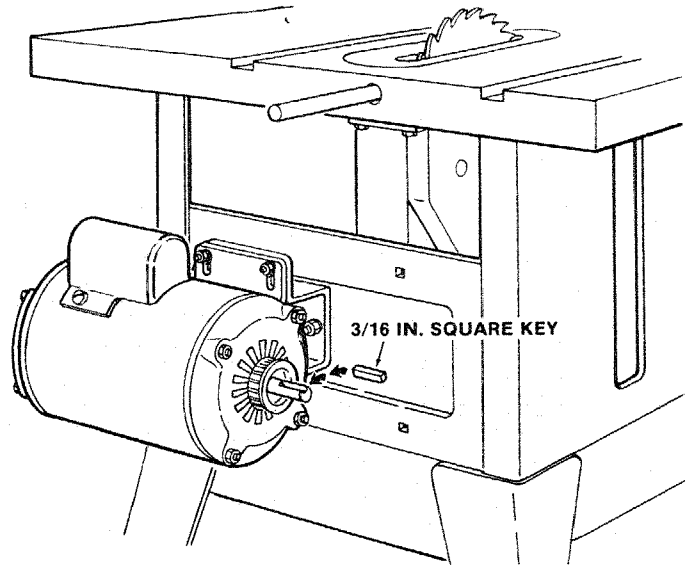

3. Loosen the 2 setscrews in the MOTOR CONNECTOR. Line up the keyway in MOTOR CONNECTOR with the 3/16 in. square key on the motor shaft.
4. Slide the MOTOR CONNECTOR onto the motor shaft as far as it will go. SECURELY tighten 2 setscrews. Test setscrews by trying to slide motor connector off motor shaft.

IMPORTANT: Make sure the MOTOR CONNECTOR is pushed on the shaft as far as it will go. (Approx. 3/8 inch from motor end shield.)

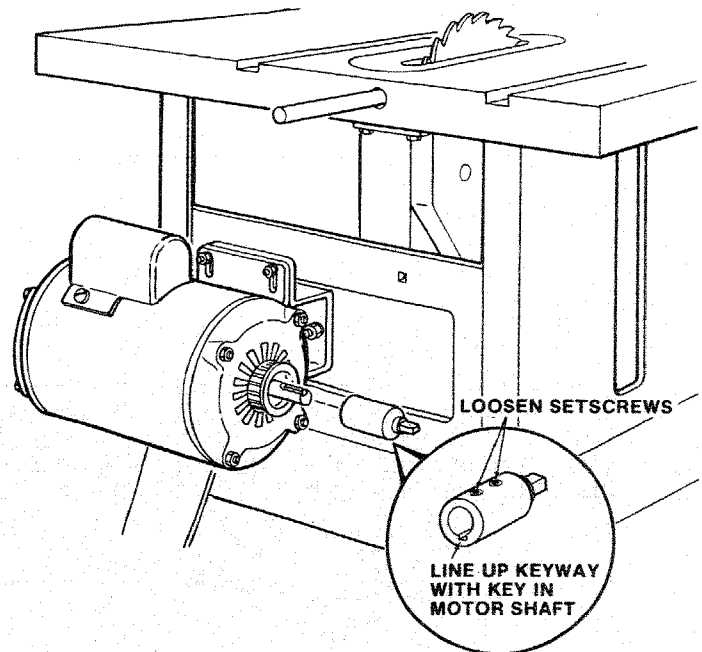
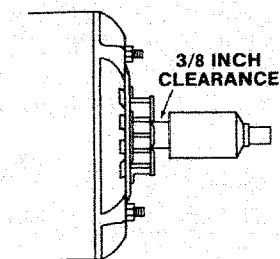

5. Remove the plastic covers from the ends of the SHAFT HOUSING.

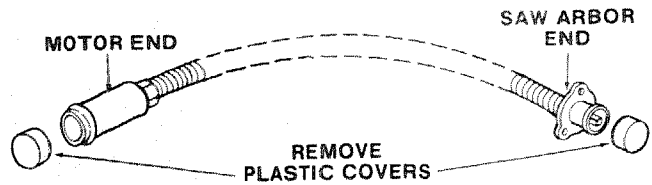

6. Push the saw arbor end of the flexible shaft out of the SHAFT HOUSING until it is approximately 1 inch above the end of the SMALL FERRULE.

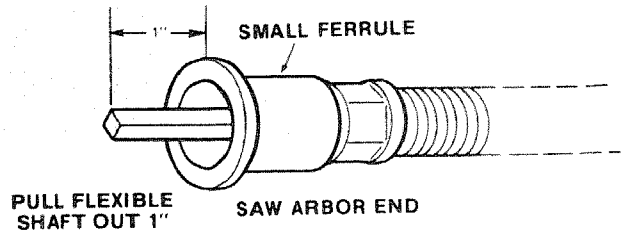

7. Insert the flexible shaft assembly through the opening in the side of the saw base. Line up the SQUARE END of the FLEXIBLE SHAFT with the square hole in the arbor shaft, holding square end of flexible shaft insert the FLEXIBLE SHAFT into the square hole in the arbor as far as it will go.

IMPORTANT: Make sure the FLEXIBLE SHAFT is inserted as far as it will go. Approximately 3/4 inch.

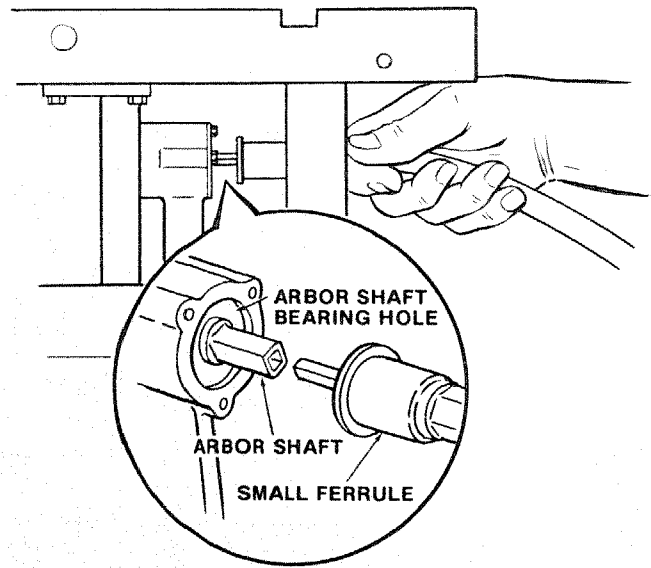

8. Insert SMALL FERRULE on SHAFT HOUSING into the arbor shaft bearing hole.

Line up SHAFT RETAINER with holes in arbor housing and fasten with three 10-32 x 3/8 Pan Head Screws and three No. 10 Lockwashers. Make sure this holds the small ferrule against the arbor shaft bearing hole. Tighten screws.

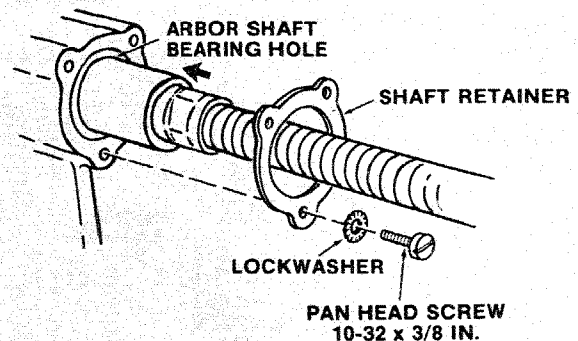

9. Bend the SHAFT HOUSING toward the motor as illustrated. Insert end of LARGE FERRULE over MOTOR CONNECTOR and line up SQUARE END of flexible shaft with square hole in MOTOR CONNECTOR.

NOTE: If FLEXIBLE SHAFT is not properly positioned in the square hole of the MOTOR CONNECTOR it will not be possible to make this connection. It may be necessary to carefully rotate the blade to line up the SQUARE END of the flexible shaft with the square hole in the MOTOR CONNECTOR.

10. Push LARGE FERRULE as far as it will go against the motor end cap. If it does not enter motor end cap to ferrule bead, rotate saw blade while pushing ferrule toward motor to permit the square ends of the core to enter their square mating holes deep enough to allow ferrule to be correctly positioned.

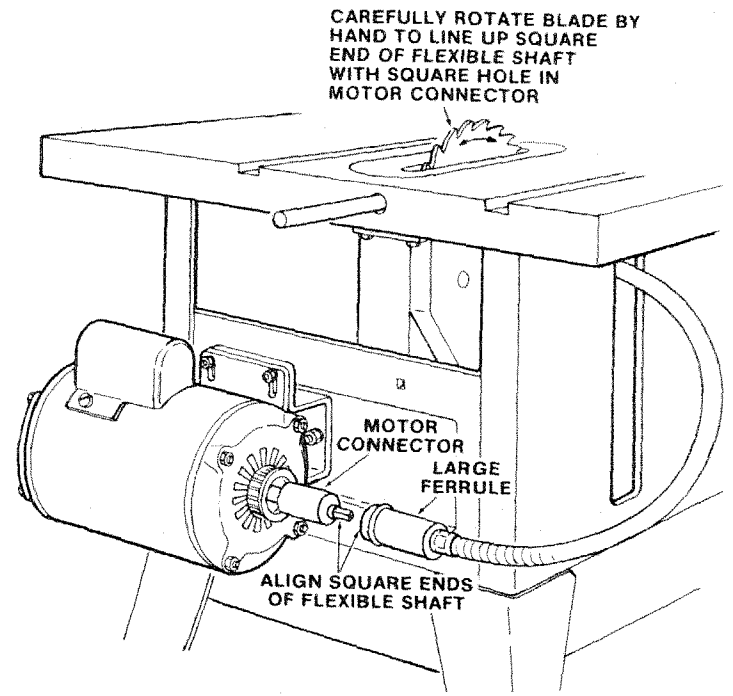

11. Assemble upper and lower shaft bracket by inserting 1/4-20 x 3/4 carriage bolts in upper and lower square holes on the saw base rear panel and then through the slotted hole in the shaft brackets. Assemble 17/64 x 3/4 x 1/16 washer, External Type Lockwasher, and 1/4-20 Hex Nut. Finger tighten.

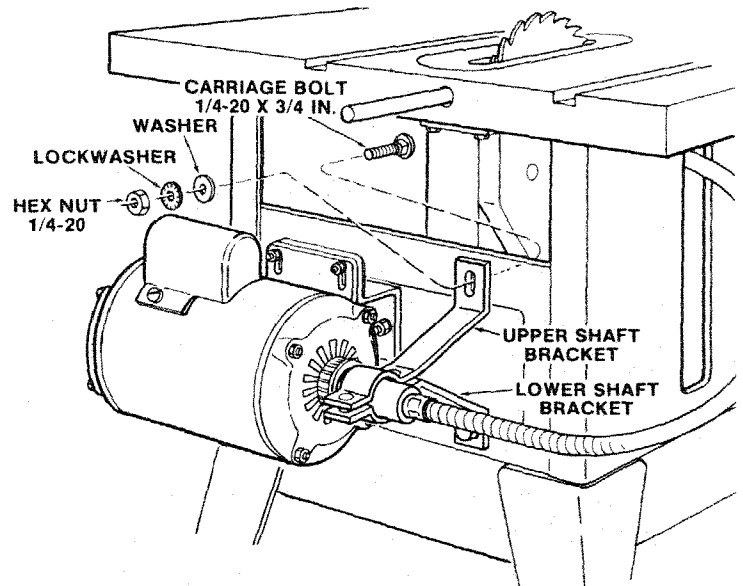

12. Position the upper and lower shaft brackets so they wrap around the LARGE FERRULE on the SHAFT HOUSING. Bottom bracket should just contact and support LARGE FERRULE. Tighten nuts that hold the shaft brackets to the saw base.
13. Assemble two 1/4-20 x 1 in. Hex Head Screws, External Lockwashers, and 1/4-20 Hex Nuts to clamp upper and lower brackets together. Do not tighten.

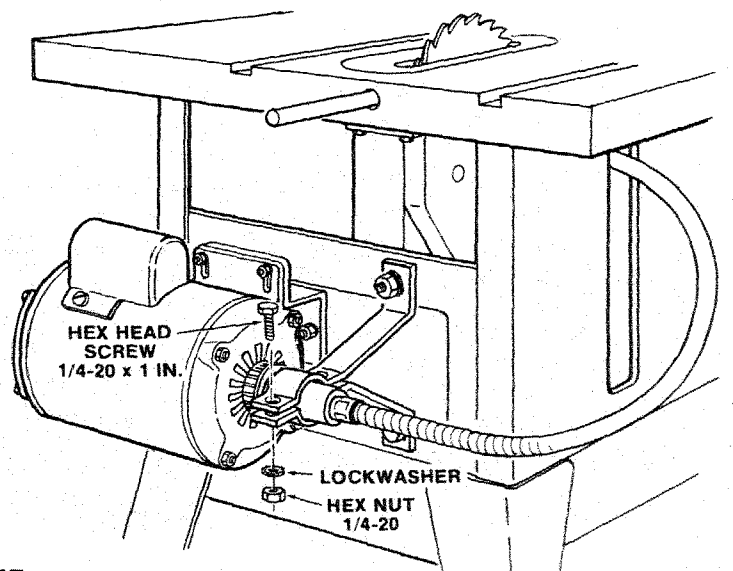

14. **CAUTION:** Overtightening shaft bracket bolts may cause damage to bracket or ferrule.

With end of LARGE FERRULE inserted into recess in motor end cap tighten 2 Hex Head nuts on shaft brackets. LARGE FERRULE must be pushed against the motor end cap as far as it will go. Tighten nuts but do not OVERTIGHTEN. The shaft brackets hold the LARGE FERRULE in place. Nuts should be securely tightened to prevent movement.

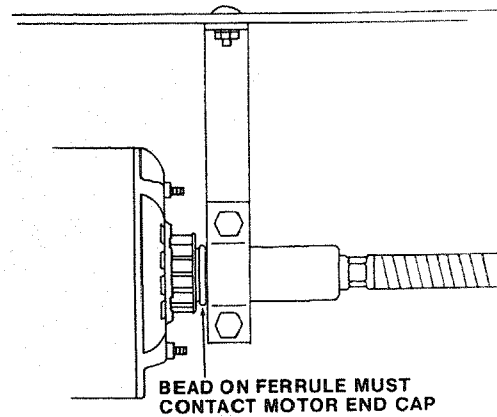

IMPORTANT: The LARGE FERRULE should be centered over the MOTOR CONNECTOR (now located inside of LARGE FERRULE), to prevent the MOTOR CONNECTOR from contacting the LARGE FERRULE.

15. Carefully turn saw blade by hand to make sure MOTOR CONNECTOR does not hit LARGE FERRULE. If they are in contact, it will cause a noise and cause resistance to rotation.

16. If the MOTOR CONNECTOR does hit the LARGE FERRULE loosen the nuts holding the shaft brackets to the saw base, and the nuts holding the LARGE FERRULE in the shaft brackets. Adjust the brackets and the LARGE FERRULE until the LARGE FERRULE is centered and is not hit by the MOTOR CONNECTOR.

NOTE: It may be necessary to raise or lower motor on motor mount slightly. Be sure to reposition shaft brackets as required.

17. Tighten nuts.

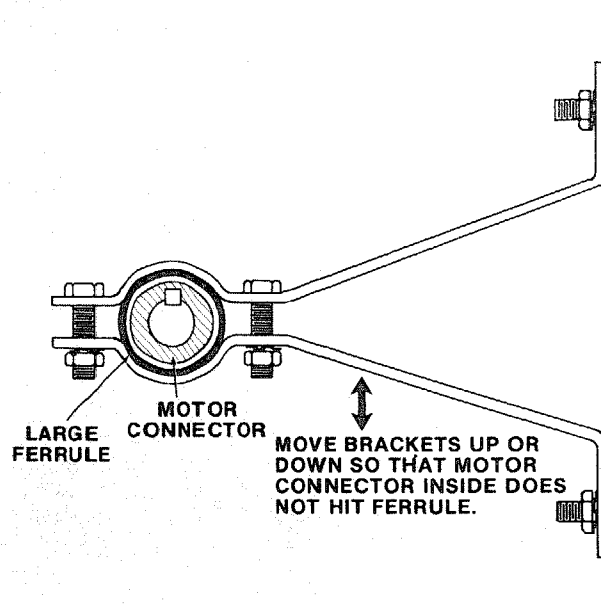

ATTACHING AND ASSEMBLING TABLE EXTENSIONS

From among the loose parts find the following hardware: (Quantity indicated is for 2 extensions)

Ref. No.	Description	Qty.
1	Corner Support Bracket	4
2	Corner Stiffener Bracket	4
3	Truss Hd. Screw, 1/4-20 x 1	16
4	External Lockwasher, 1/4	16
5	Hex Nut, 1/4-20	16
6	Flat Washer (Dia. of Hole 17/64)	4

HARDWARE FOR INSTALLING EXTENSIONS TO SAW TABLE

7	Hex Hd. Screw, 5/16-18 x 1-1/4	8
8	External Lockwasher, 5/16	8
9	Hex Nut, 5/16-18	8
10	Flat Washer (Dia. of Hole 11/32)	8

Assemble brackets with hardware as shown.

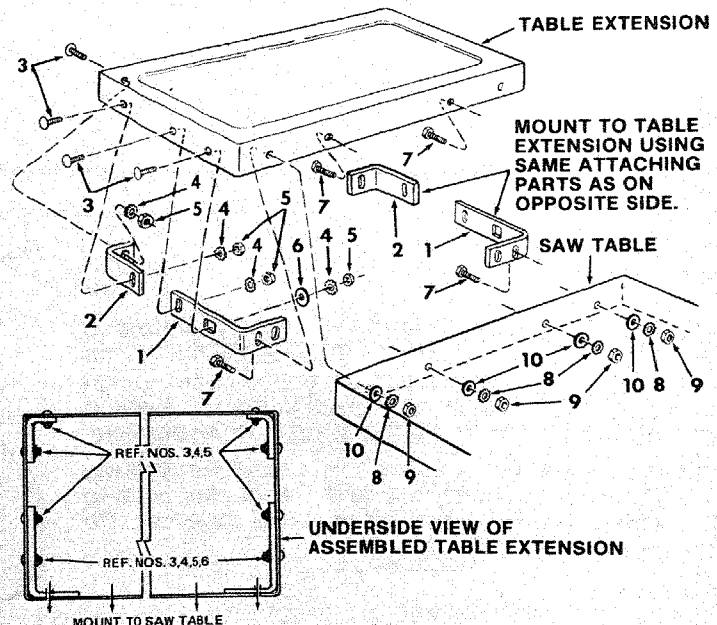

Insert four (4) 5/16-18 x 1-1/4 in. long screws through holes in each EXTENSION then through table. Install flat washer, lockwashers, and nuts on the screws . . . DO NOT TIGHTEN.

Align front edge of extension with front edge of saw table. Pull Extension UPWARDS above table surface . . . SLIGHTLY TIGHTEN SCREWS using 1/2 in. wrench.

Using small block of hardwood and hammer, tap extension DOWNWARDS at front, center and rear, until it is EVEN with table surface . . . TIGHTEN SCREWS.

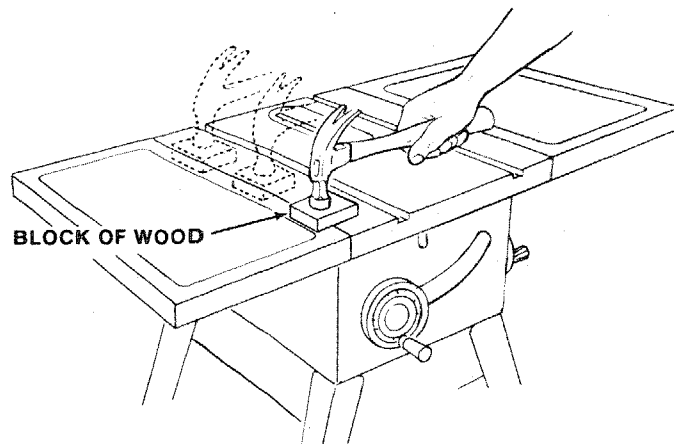

ALIGNING EXTENSIONS

Lay REAR FENCE GUIDE BAR on table to act as a straightedge. If outer edge of extension is higher or lower than table surface:

1. Slightly loosen nut holding the corner support bracket to extension using 7/16 in. wrench.
2. Move end of extension up or down until outer edge is even with table surface . . . check with GUIDE BAR . . . tighten nuts.
3. Recheck INNER edge of extension to make sure it has not moved . . . readjust, if necessary.
4. Adjust right extension in same manner.

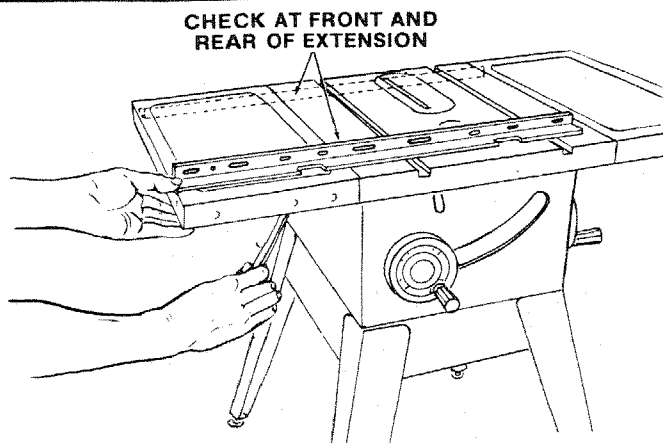

MOUNTING SWITCH

1. From among loose parts find the following:
 - 2 Hex Head Screws, 5/16-18 x 3/4 in. long
 - 2 Flatwashers (dia. of hole 21/64 in.)
 - 2 External Lockwashers
 - 2 Hex Nuts, 5/16-18
2. Insert two 3/4 inch screws through two flat washers then through holes in switch.
3. Insert screws through holes eight and ten in front fence guide bar as illustrated.
4. Install two lockwashers and nuts. Tighten nuts.

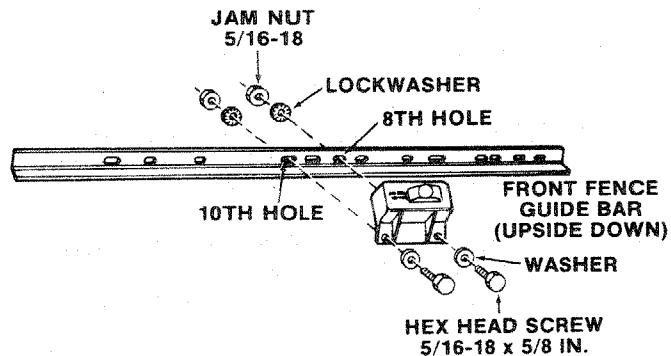

INSTALLING RIP FENCE GUIDE BARS

1. From among the loose parts find the following hardware:
 - 2 Hex Head Screws, 5/16-18 x 1-3/4 in. long
 - 2 Hex Head Screws, 5/16-18 x 1 in. long
 - 4 External Lockwashers, 5/16 in. (approx. dia. of hole 5/16 in.)
 - 4 Hex Nuts, 5/16-18 (approx. dia. of hole 5/16 in.)
 - 2 Spacers, 3/4 in. dia. x 1/2 in. long
 - 2 Self-threading nuts
 - 1 Fence Guide Bar Rod
2. Lay guide bars on saw table.

NOTE: The various holes in the bar allows them to be positioned on this saw and also makes them adaptable to other models.
3. Insert a 1-3/4 inch long screw through the THIRD hole IN THE FRONT BAR as illustrated . . . Insert another 1-3/4 inch long screw through the SEVENTH hole in bar.

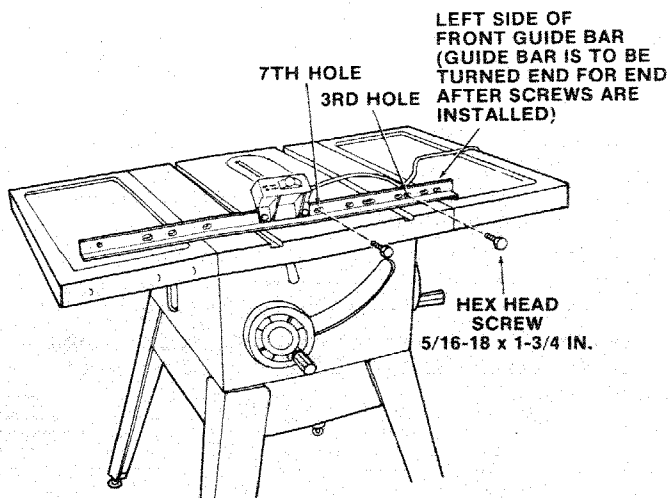

4. Place spacers on screws.

- Turn front bar end for end and insert bolts through holes in middle and on right sides of front of saw table as illustrated . . . install lockwashers and nuts. **DON'T SCREW NUTS ON ALL THE WAY**, just get them started on the screws.

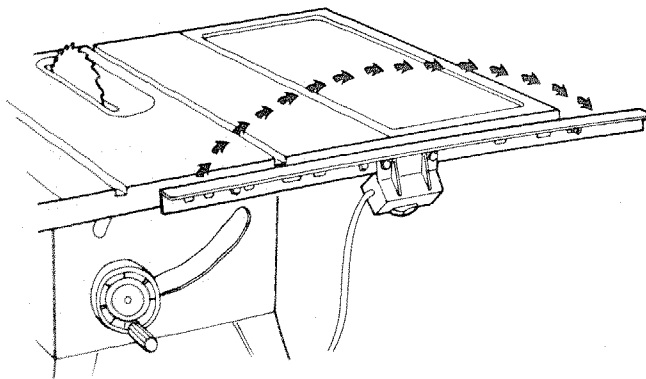

- Remove the 3 screws from rear of table extension.
- Insert 1 in. long screws in **SECOND** and **FOURTH** or **FIFTH** holes of rear bar and attach to table the same way as front bar.
- Insert ends of **FENCE GUIDE BAR ROD** through holes in bars as illustrated.

NOTE: The ends of the **ROD** are not threaded . . . the **SELF THREADING NUTS** will cut threads on the rod as they are screwed on. Just start nuts onto ends of rod.

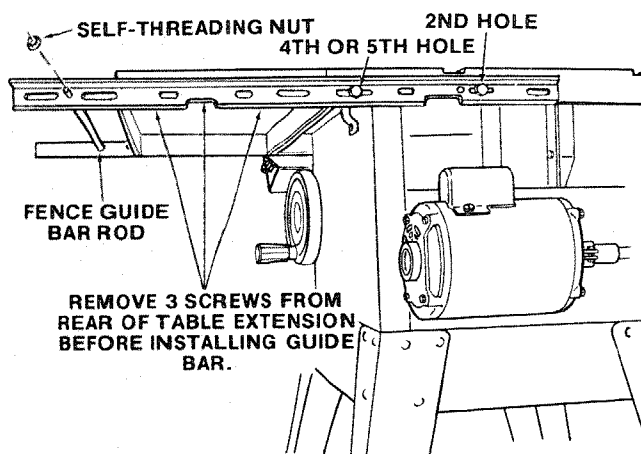

- Hold rod with one hand and with a 1/2 in. wrench or pliers start screwing on **ONE** of the nuts only **A TURN OR TWO** . . . screw on other nut the same way.
- Using **TWO** 1/2 in. wrenches or pliers tighten both of the nuts.

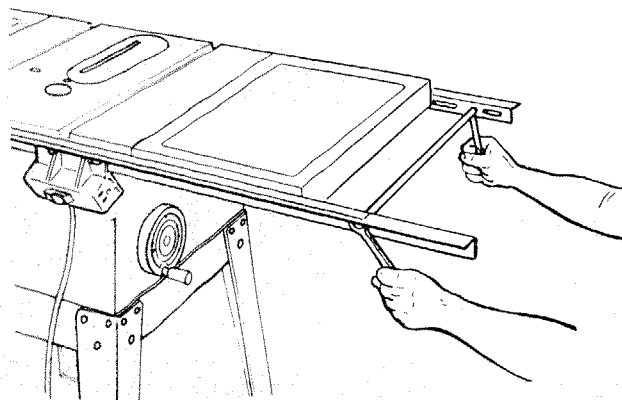

- Slide the bars so that screws are in the **MIDDLE** of the slotted holes.
 - Position rip fence over miter gauge groove, holding up the rear end while engaging front end with bar . . . lower fence onto table.
- NOTE:** It may be necessary to loosen fence knob to allow fence to be installed on rip rail.

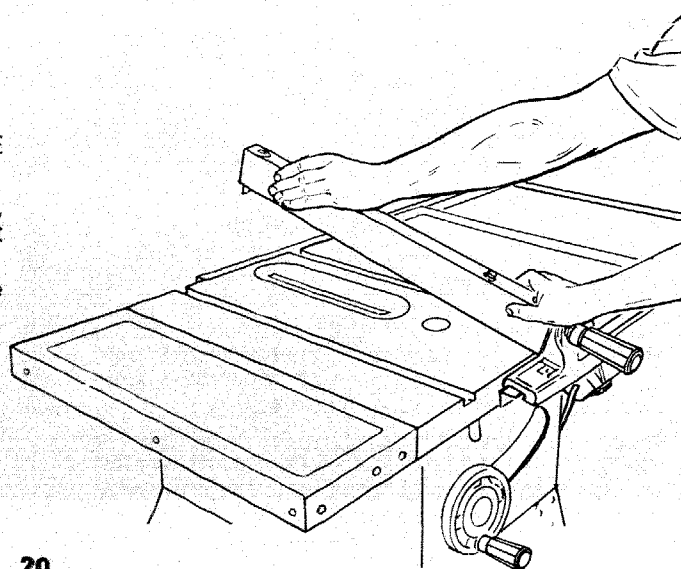

13. Raise blade all the way up.
14. Carefully move fence against blade.
15. Move front bar until "0" mark on rip scale is approximately in line with indicator.
16. Move FRONT bar upwards until fence is approximately 1/32 in. above table ... tighten screw at left end of bar.

NOTE: Fold a piece of newspaper making 8 thicknesses and place between rip fence and table to act as a spacer. This will hold the fence off of the table approx. 1/32 in.

17. Adjust rear bar so that the fence is approximately 1/32 in. above table ... make sure it is square with fence guide bar rod ... tighten screw at end of bar.
18. Replace screws in rear of table extension ... be sure top surface of extension is PARALLEL to top surface of rear guide bar.

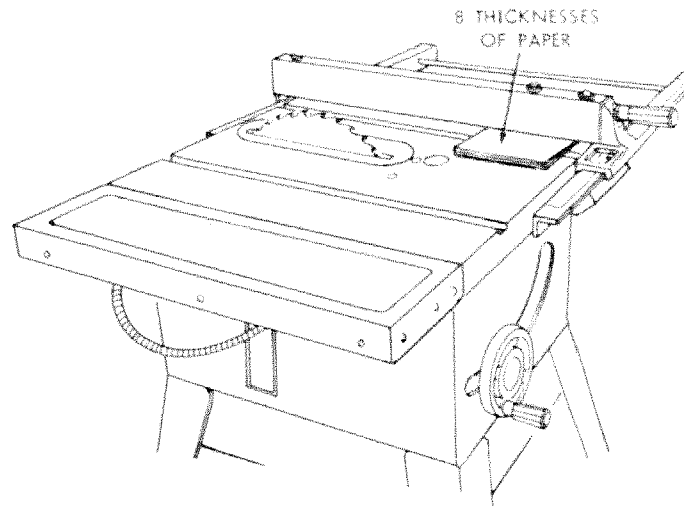

19. Move fence to RIGHT edge of table ... make sure it is approx. 1/32 in. above table at front and rear and tighten screws.

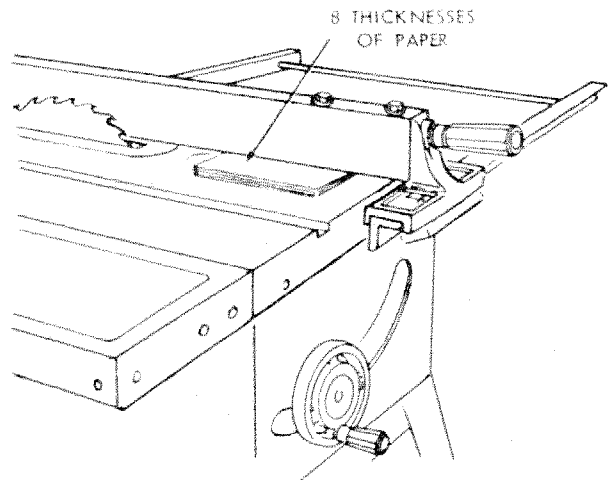

ALIGNING RIP FENCE

The fence should slide easily along the bars and always remain in alignment (parallel to sawblade and miter gauge grooves).

The alignment is maintained by a spring underneath the rip fence which bears against the front guide bar.

To move the fence, loosen the lock handle and grasp the fence with one hand at the front.

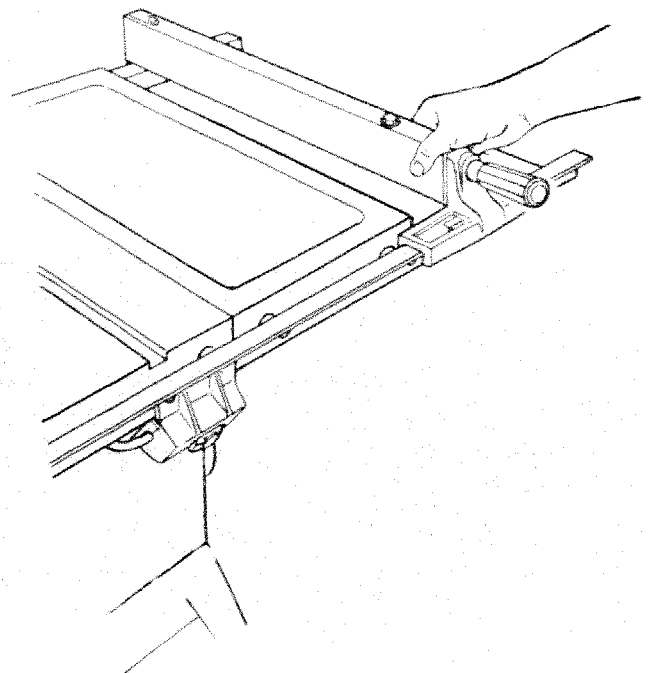

For very close adjustments, grasp the guide bar with both hands and move the fence with your thumbs.

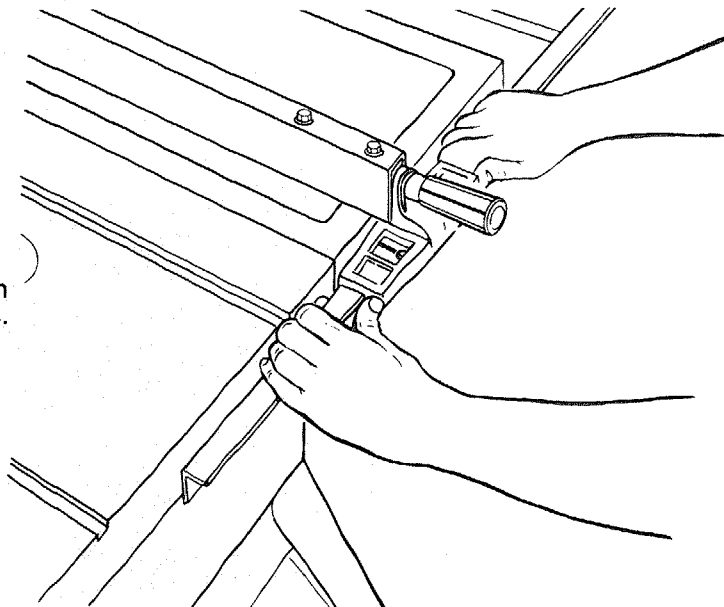

Place fence on saw but **DO NOT LOCK IT**. Move the **REAR END** of the fence slightly to the right or left . . . when you release it, the fence should "spring" back to its original position. If it does not, the spring pressure must be **INCREASED**.

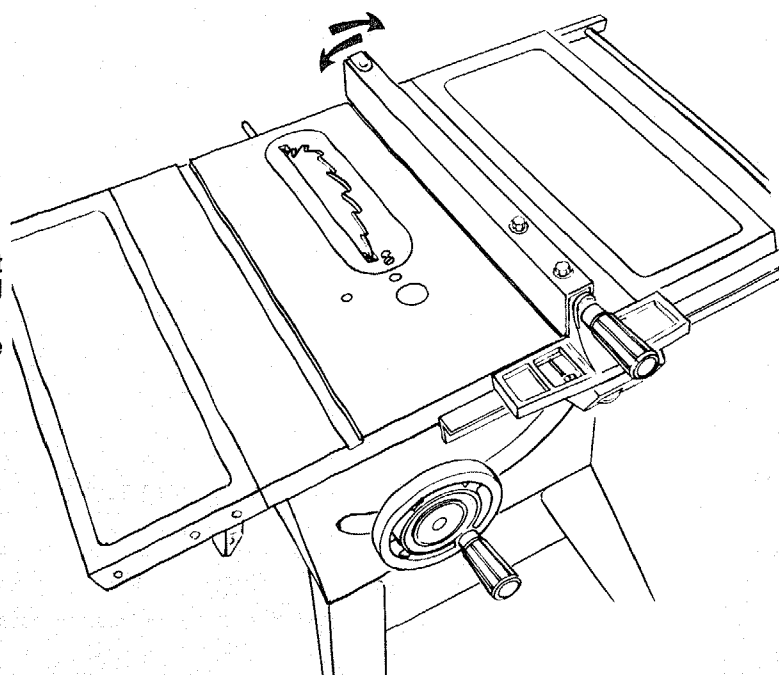

1. Loosen the screws.
2. Move Spring slightly toward front of fence.
NOTE: Applying a coat of paste wax to the rails will allow fence to be moved more easily.

If the fence does not slide easily along the bars, the pressure of the spring can be **REDUCED**.

1. Loosen the screws.
2. Move spring slightly toward rear of fence . . . tighten screws.

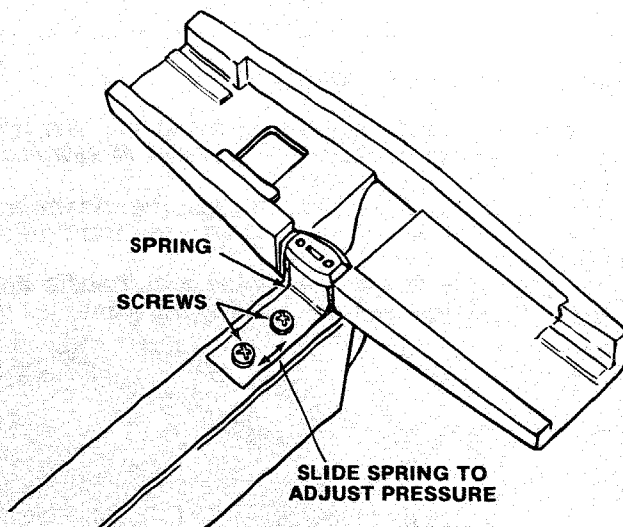

3. The rip fence must be PARALLEL with the sawblade and miter Gauge grooves . . . Move fence until it is along side of groove. Do NOT LOCK IT. It should be parallel to groove. If it is not;
 - A. Loosen the two "Hex Head Screws."
 - B. Hold fence head tightly against bar . . . move end of fence so that it is parallel with groove.
 - C. Alternately tighten the screws.

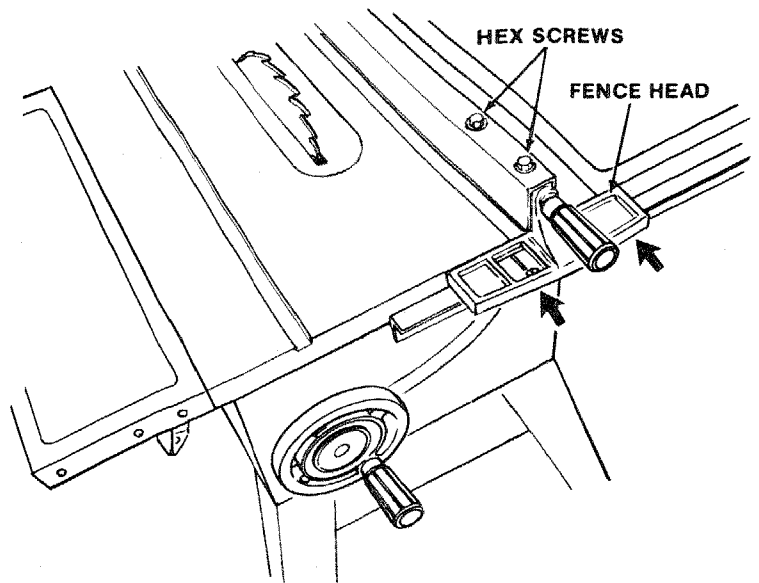

ADJUSTING RIP SCALE INDICATOR

1. Turn ELEVATION HANDWHEEL clockwise until blade is up as high as it will go.
IMPORTANT: BLADE must be SQUARE (90°) to TABLE, in order to ALIGN rip fence.
2. Using a rule, position fence on right side of sawblade 2 in. from the sides of the teeth . . . tighten lock handle.
3. Loosen screw holding the indicator . . . adjust so that it points to "2" on the rip scale . . . tighten screw.
NOTE: If you cannot adjust indicator so that it points to "2", loosen the screws holding the front guide bar and move the guide bar.

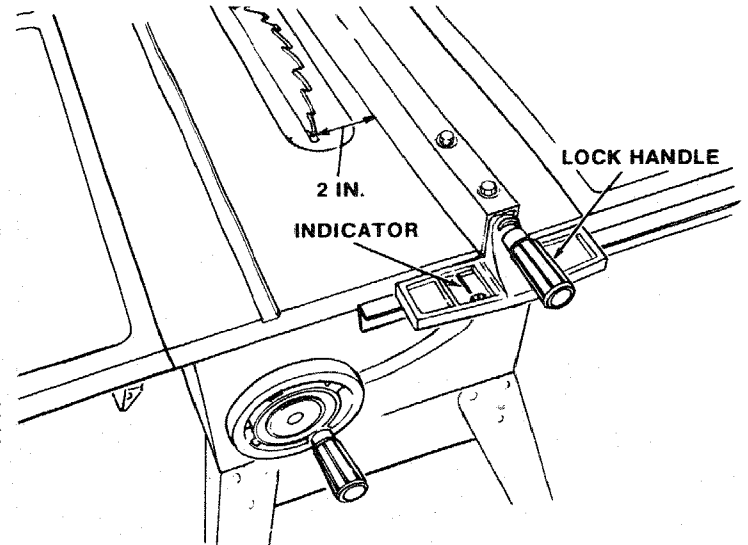

INSTALLING BLADE GUARD

1. From Among the loose parts find:
 - 4 Truss Head Screws 1/4-20 x 3/4 in. long
 - 2 Hex Socket Setscrews 1/4-20 x 1 in. long
 - 4 Washers 17/64 x 5/8 x 1/32
 - 6 Lockwashers 1/4 in. External Type (approx. dia. of hole 1/4 in.)
 - 2 Hex Head Nuts 1/4-20 (approx. dia. of hole 1/4 in.)
 - 2 Wing Nuts 1/4-20 (approx. dia. of hole 1/4 in.)
 - 1 Spreader Support
 - 1 Plate Nut
 - 1 Spreader Clamp
 - 1 Spreader Bracket

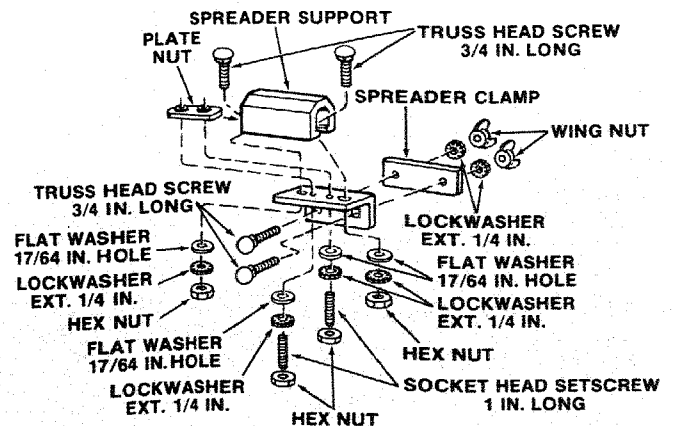

WARNING: TO AVOID INJURY DUE TO ACCIDENTAL START, TURN SWITCH "OFF" AND REMOVE PLUG FROM POWER SOURCE OUTLET.

2. MAKE SURE THE BLADE IS ALL THE WAY UP AND SQUARE WITH THE TABLE.
3. Position SPREADER SUPPORT on rod until it is even with the end of the rod.

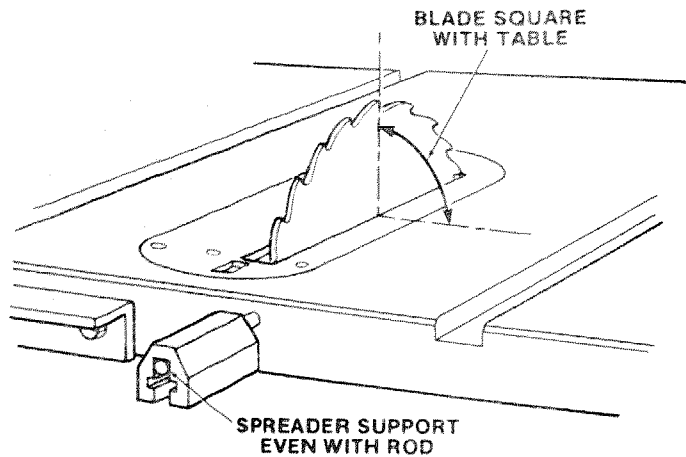

4. Assemble the 7/8 in. long setscrews, nuts, lockwashers and washers to the SPREADER SUPPORT BRACKET and slip the nuts into the slot in the spreader support.
5. Finger tighten ONLY THE HEX NUTS.

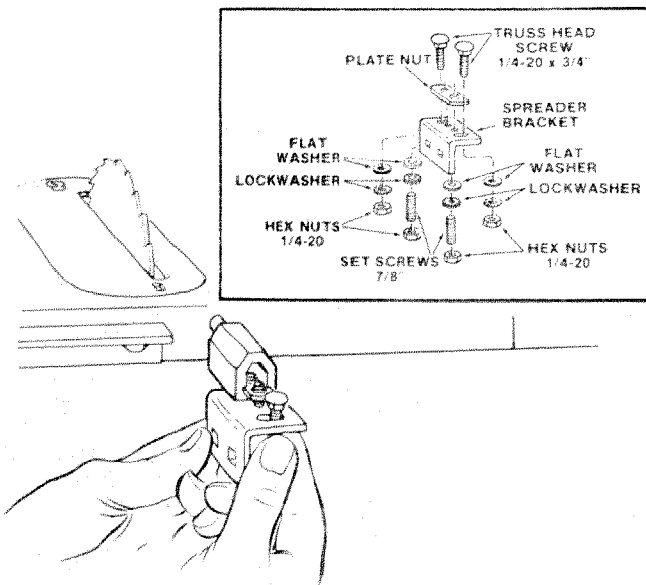

6. Lay a piece of flat straight wood and a square on saw table and rotate the SPREADER SUPPORT until the bracket is aligned with square.
7. MAKE SURE END OF SUPPORT, BRACKET AND ROD ARE EVEN . . . using a 1/8 in. setscrew wrench, TIGHTEN THE SETSCREWS ONLY.

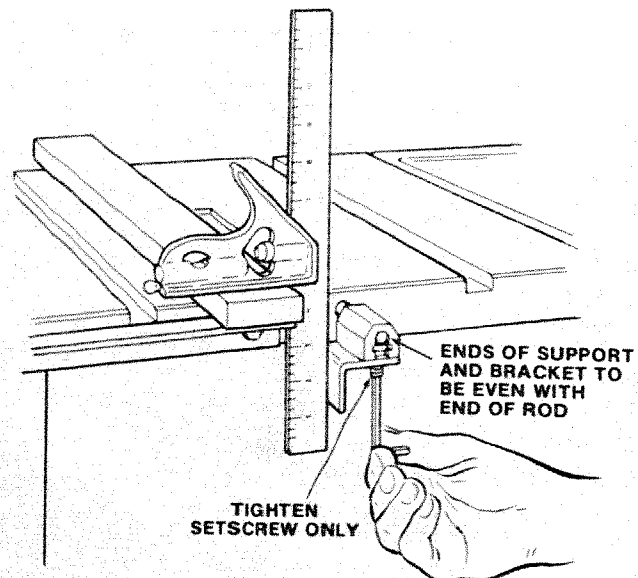

ALIGNING SPREADER

WARNING: TO AVOID INJURY FROM ACCIDENTAL START, TURN SWITCH OFF AND REMOVE PLUG FROM POWER OUTLET.

IMPORTANT: The SPREADER must always be PARALLEL to the sawblade and in the MIDDLE of the cut (KERF) made by the sawblade.

NOTE: The spreader is thinner than the width of the KERF by approximately six thicknesses of paper.

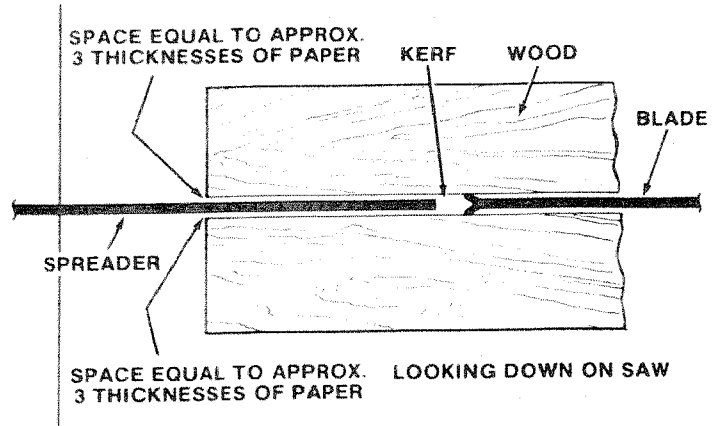

1. Make two folds in a small piece (6 x 6 in.) of ordinary NEWSPAPER making three thicknesses. The folded paper will be used as a "spacing gauge".

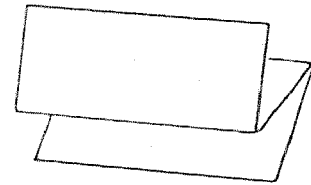

2. Install TRUSS HEAD SCREWS, SPREADER CLAMP and WING NUTS to spreader bracket. Do not tighten wing nuts. Place spreader between spreader clamp and bracket. Move forward until all three are in line. TIGHTEN WING NUTS.
3. Lift up both ANTIKICKBACK PAWLS . . . insert one of the setscrew wrenches or a pencil in the notches to hold the pawls out of the way. Hold guard so it doesn't fall while positioning spreader.
4. Lay a piece of straight flat wood against the sawblade. Insert folded paper between spreader and strip of wood.
5. MAKE SURE THE HEX NUTS UNDERNEATH ARE LOOSE.
6. Hold the spreader tightly against the wood and make sure the wood is against the saw blade. TIGHTEN THE HEX NUTS.
This will align the spreader in the middle of the cut (KERF) made by sawblade.

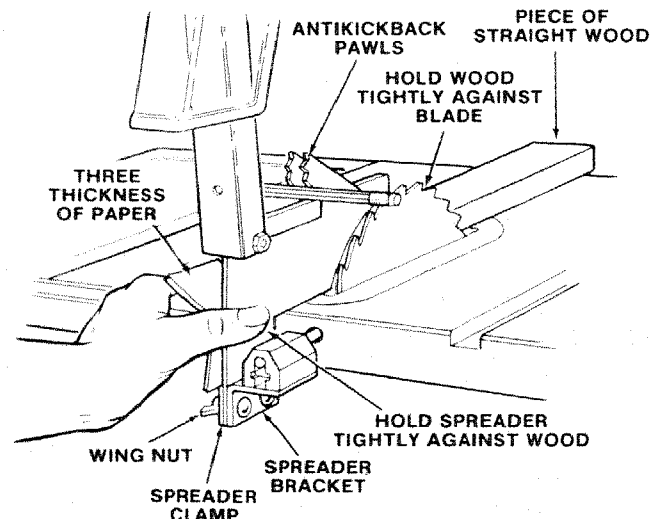

ADJUSTING MITER GAUGE

NOTE: The slots for the stop pin and the graduations are manufactured to very close tolerances which provide accuracy for average woodworking. In some cases where extreme accuracy is required, when making angle cuts, for example, make a trial cut and then recheck it.

If necessary, the miter gauge head can be swiveled slightly to compensate for any inaccuracy.

1. Loosen the "knob" and pull "stop pin" OUT.
2. Swivel the head . . . position it at "0" . . . push the stop pin IN . . . lock the handle.
3. The HEAD should be square with the Bar and the pointer should point to "0". Readjust the pointer if necessary.

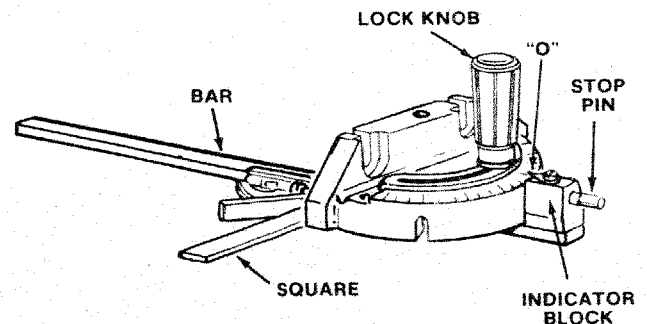

4. If the head is not square with the bar, adjustments are required.

A. Loosen the "knob" (1) and the "two screws" (2).

B. Position the HEAD square with the BAR using a combination square.

C. PUSH the STOP PIN into the slot in the head at "0" . . . push the pin into the slot and twist it. Lock the knob.

D. Recheck with the square. If the head is still not square, loosen the screws (2) and readjust the INDICATOR BLOCK.

E. With the head square with the bar and the pin pushed into the slot adjust the pointer (3) to point to "0".

F. The miter gauge head must rest on top of the bar without being able to move up and down . . . yet it must swivel freely.

G. The swiveling movement of the head can be adjusted by tightening or loosening the setscrew (4) . . . using the 1/8 in. setscrew wrench.

NOTE: The setscrew is located inside of the head. To reach it, swivel the head to 60 degrees and turn the miter gauge upside down.

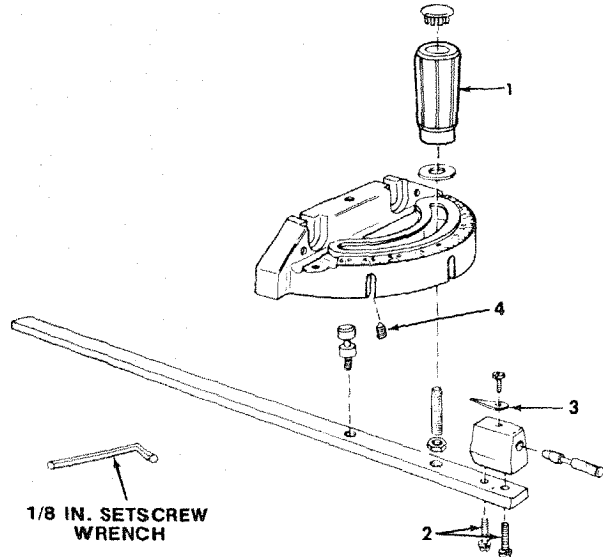

PLUGGING IN MOTOR

1. From among the loose parts, find two wire ties.
2. Route motor cord along right side of cabinet and snap ties in 1/4" hole in side of cabinet. Secure two cords in wire ties.
3. Plug motor cord into outlet on side of switch box.

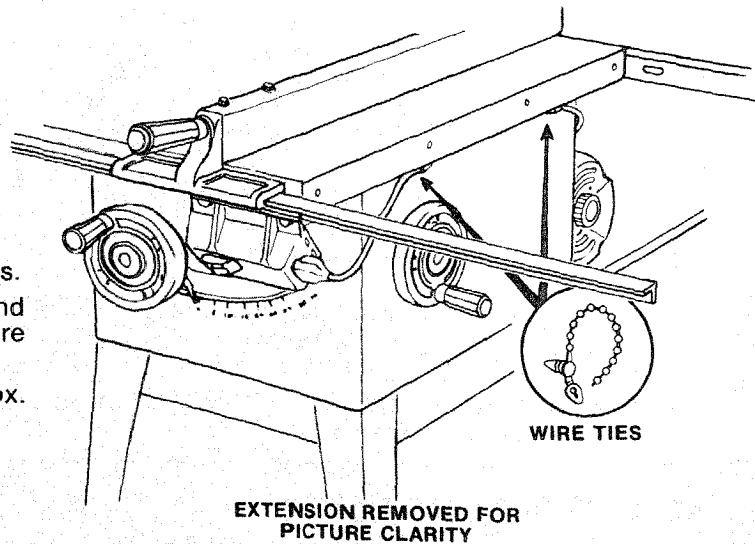

GETTING TO KNOW YOUR SAW

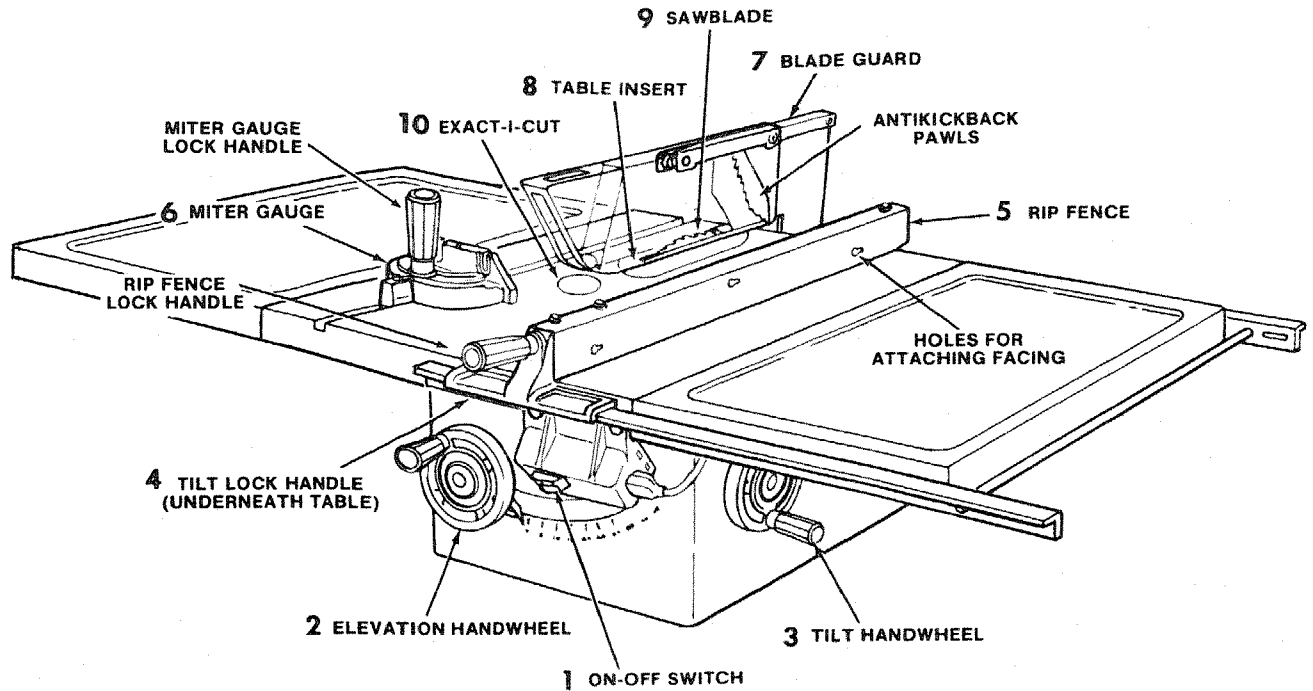

1 ON-OFF SWITCH

CAUTION: Before turning switch on, make sure the blade guard is correctly installed and operating properly.

The On-Off Switch has a locking feature. THIS FEATURE IS INTENDED TO PREVENT UNAUTHORIZED AND POSSIBLE HAZARDOUS USE BY CHILDREN AND OTHERS.

- A. TO turn saw ON . . . stand to either side of the blade never in line with it . . . insert finger under switch lever and pull END of lever out. Do not cycle the motor switch on and off rapidly, as this may cause the sawblade to loosen. In the event this should ever occur, allow the sawblade to come to a complete stop and retighten the arbor nut normally, not excessively. Never leave the saw while the power is "ON".
- B. TO turn saw OFF . . . PUSH lever in. Never leave the saw until the cutting tool has come to a complete stop.
- C. TO lock switch in OFF position . . . hold switch IN with one hand . . . REMOVE key with other hand.

WARNING: FOR YOUR OWN SAFETY, LOWER BLADE OR OTHER CUTTING TOOL BELOW TABLE SURFACE. (IF BLADE IS TILTED, RETURN IT TO VERTICAL (90°) POSITION). ALWAYS LOCK THE SWITCH "OFF". WHEN SAW IS NOT IN USE . . . REMOVE KEY AND KEEP IT IN A SAFE PLACE . . . ALSO . . . IN THE EVENT OF A POWER FAILURE (ALL OF YOUR LIGHTS GO OUT) TURN SWITCH OFF . . . LOCK IT AND REMOVE THE KEY. THIS WILL PREVENT THE SAW FROM STARTING UP AGAIN WHEN THE POWER COMES BACK ON.

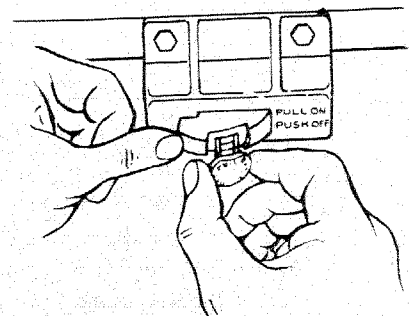
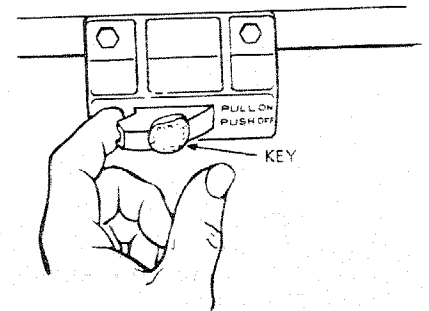
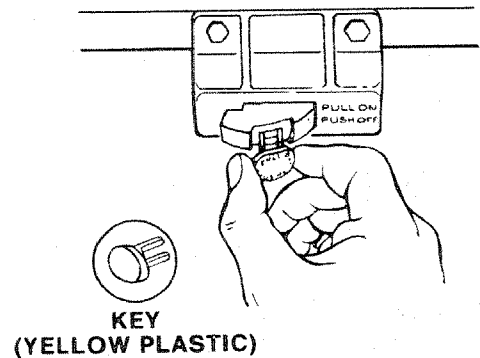

2 ELEVATION HANDWHEEL . . . elevates or lowers the blade. Turn clockwise to elevate . . . counterclockwise to lower.

NOTE: Any time sawblade has been elevated to 2-5/8 inches or higher above the table it will be necessary to lower the blade by turning the elevation handwheel 5 turns counterclockwise before tilting to bevel.

3 TILT HANDWHEEL . . . tilts the blade for bevel cutting. Turn clockwise to tilt toward left . . . counterclockwise to tilt toward vertical.

When the blade is tilted to the LEFT as far as it will go, it should be at 45° to the table and the bevel indicator should point 45°.

NOTE: There are LIMIT STOPS on the saw which prevent the blade from tilting beyond 45° to the LEFT and 90° to the RIGHT. (See "Adjustments" section "Blade Tilt, or Squareness of Blade to Table").

4 TILT LOCK HANDLE . . . locks the blade in the desired tilt position. To loosen, turn counterclockwise. Push handle in and turn it to another position if necessary in order to tighten or loosen.

IMPORTANT: Be sure handle is hanging in the "DOWN" position before tilting blade. If it is pointing to the 1 o'clock position it may jam on underside of the table and bend the locking bolt.

5 RIP FENCE . . . is locked in place by tightening the lock knob. To move the fence, loosen the knob and grasp the fence with one hand at the front.

Holes are provided in the rip fence for attaching a wood facing when using the dado head, or molding head.

Select a piece of smooth straight wood approx. 3/4" thick, at least as long as the rip fence, and at least 7-1/2" wide (high) to permit clamping of featherboards.

Attach it to the fence with three Round Head #10 Wood Screws 2 in. long. To remove the facing, loosen the screws, slide the facing forward and pull the screws through the round holes.

If you are making a rip type cut in material thinner than 3/16 in. while the fence is positioned over the depressed area of table extension, the facing should be attached to the fence so that the bottom edge touches the top surface of the extension. In this case, the facing must be shorter than the fence. This will prevent thin material from sliding under the rip fence.

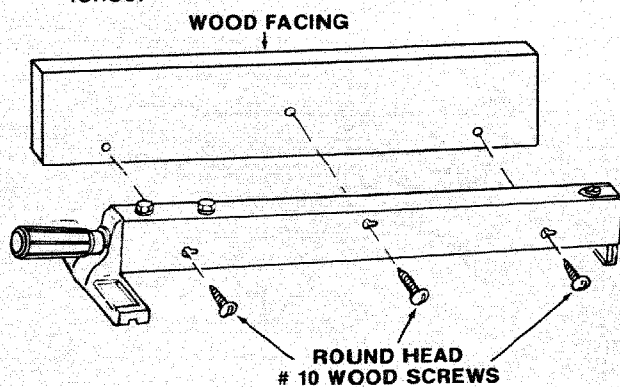

6 MITER GAUGE . . . head is locked in position for crosscutting or mitering by tightening the lock knob. ALWAYS LOCK IT SECURELY WHEN IN USE.

There are slots for the stop pin at the 45 degree right and left positions for conveniently setting the Miter Gauge to cut miters.

NOTE: The slots for the stop pin and the graduations are manufactured to very close tolerances which provide accuracy for average woodworking. In some cases where extreme accuracy is required, when making angle cuts, for example, make a trial cut and then recheck it.

If necessary, the miter gauge head can then be swiveled slightly to compensate and then locked.

Slots are provided in the miter gauge for attaching an AUXILIARY FACING to make it easier to cut long pieces. Be positive facing does not interfere with the proper operation of the sawblade guard.

Select a suitable piece of smooth straight wood . . . drill two holes and attach it with screws.

NOTE: When bevel crosscutting, attach facing so that it extends to the right of the miter gauge and use the miter gauge in the groove to the right of the blade.

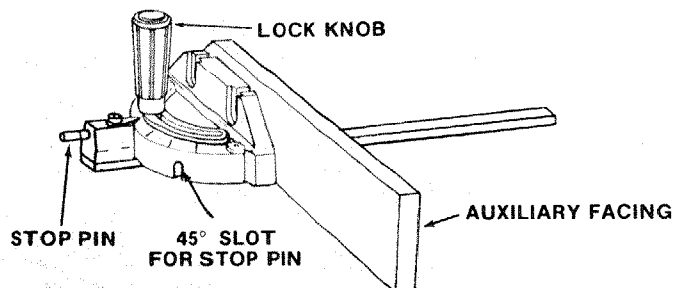

7 BLADEGUARD must always be in place and working properly for all thru-sawing cuts. That is, all cuts whereby the blade cuts completely through the workpiece.

To remove the guard for special operations, loosen the wing nuts and slide the guard off of the rod. DO NOT DISTURB THE SETTING OF THE ROD.

When replacing the guard, make sure the PIN in the rod engages with the NOTCH in the spreader support. Make sure wing screws are tightened securely.

8 TABLE INSERT is removable for removing or installing blades or other cutting tools.

WARNING: TO AVOID INJURY DUE TO ACCIDENTAL START, TURN SWITCH "OFF" AND REMOVE PLUG FROM POWER SOURCE OUTLET BEFORE REMOVING INSERT.

- A. Lower the blade below the table surface.
- B. Raise blade guard.
- C. Loosen Screw.
- D. Lift insert from front end, and pull toward front of saw.

NEVER OPERATE THE SAW WITHOUT THE PROPER INSERT IN PLACE. USE THE SAW BLADE INSERT WHEN SAWING . . . USE THE COMBINATION DADO MOLDING INSERT (9-22271) WHEN DADOING OR MOLDING.

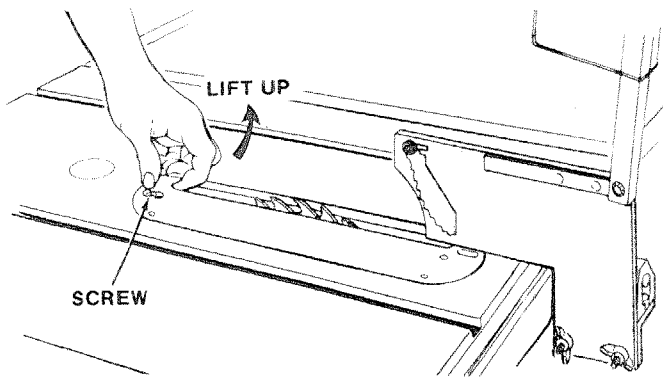

9 REMOVING AND INSTALLING SAWBLADE.
WARNING: TO AVOID INJURY DUE TO ACCIDENTAL START, TURN SWITCH "OFF" AND REMOVE PLUG FROM POWER SOURCE OUTLET BEFORE REMOVING OR INSTALLING SAWBLADE.

- A. Raise Blade Guard . . . remove insert.
- B. To REMOVE blade, place a block of wood against front of blade . . . PULL arbor wrench toward you to LOOSEN arbor nut.

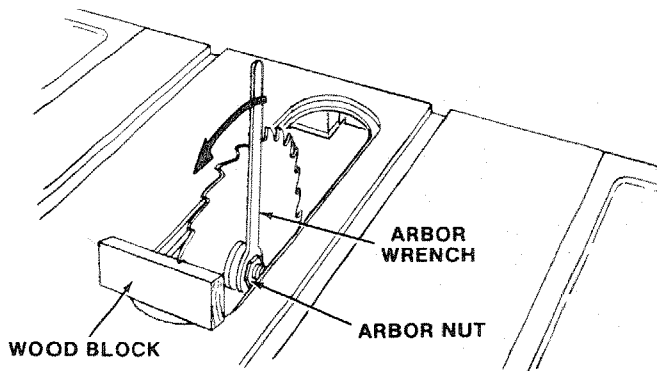

BLADE GUARD NOT SHOWN FOR PICTURE CLARITY

- C. To TIGHTEN arbor nut, place a block of wood against rear of blade . . . PUSH wrench away from you.

When installing the blade . . . make sure the teeth are pointing toward the front of the saw . . . and that the blade and collars are clean, and free from any burrs.

The HOLLOW side of the collar must be against the blade.

Always tighten the arbor nut securely.

NOTE: When using the Dado or Molding Head, it is not necessary to install the loose collar.

To replace insert.

Place insert into insert opening in table and push toward rear of saw to engage spring clip and until keyslot in insert will drop over screw. Tighten screw.

Do not tighten screw to the point where it will deflect the insert.

BLADE GUARD NOT SHOWN FOR PICTURE CLARITY

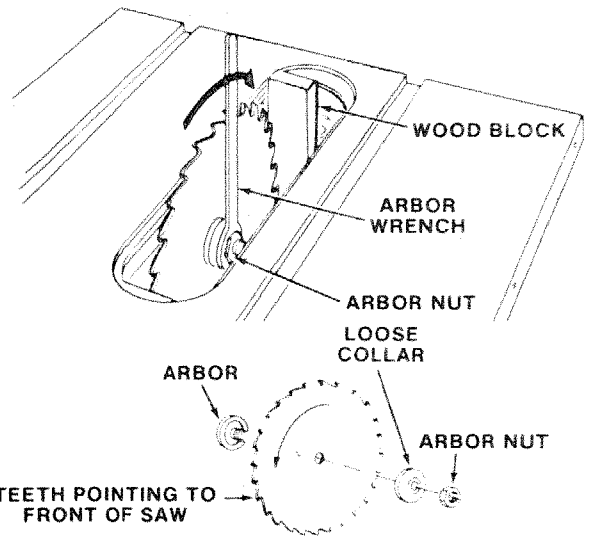

10 EXACT-I-CUT

The "yellow" plastic disc imbedded in the table in front of the sawblade, is provided for marking the location of the "sawcut" on the workpiece.

- A. Check disc . . . if it is above table surface, place a piece of hardwood on top of it and tap it down.
- B. With blade 90° (square to table) cut off a piece of wood.
- C. Pull miter gauge back until wood is over disc. Using very sharp pencil, mark a line on disc.
- D. With miter gauge in right hand groove, follow same procedure and mark another line on disc.
- E. These lines indicate the "path" of the cut (kerf) made by the sawblade.
- F. When cutting the workpiece, line up mark on workpiece with line on disc.

Use the hold-down clamp (optional accessory) on the miter gauge for greater accuracy.

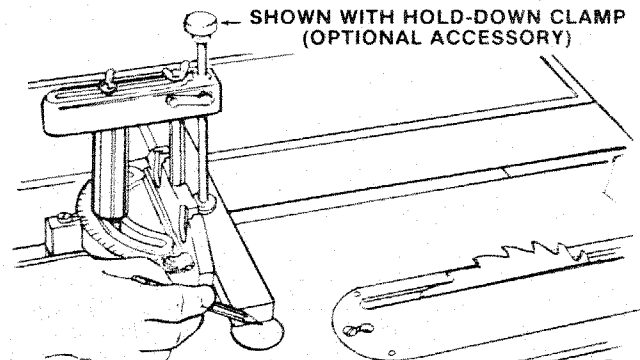

BLADE GUARD NOT SHOWN FOR PICTURE CLARITY

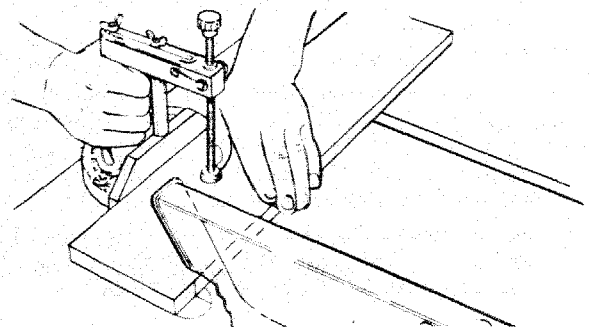

BASIC SAW OPERATION

WORK HELPERS

Before cutting any wood on your saw, study all of the "Basic Saw Operations".

Notice that in order to make some of the cuts, it is necessary to use certain devices "Work Helpers" like the Push Stick, the Push Block and the Auxiliary Fence/Work Support, which you can make yourself.

After you have made a few practice cuts, make up these "helpers" before starting any projects. Make the "Push Stick" first.

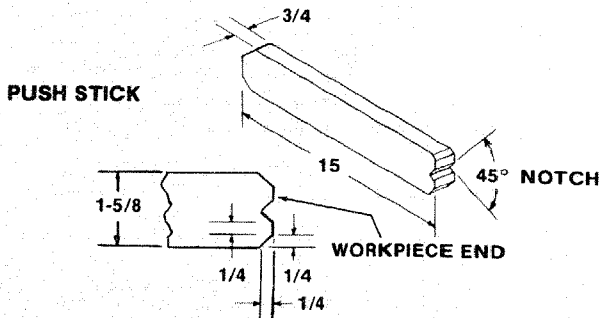

NOTE: All dimensions in inches

PUSH STICK AND PUSH BLOCK

Make the Push Stick using a piece of 1 x 2, or rip one from a wide board, say 11-1/2 in. wide, and set the rip fence 9-7/8 in. from the sawblade.

Make the Push Block using a piece of 3/8 in. and 3/4 in. plywood.

The small piece of wood 3/8 in. x 3/8 in. x 2-1/2 in. should be GLUED to the plywood... DO NOT USE NAILS. This is to prevent dulling the sawblade in the event you mistakingly cut into the push block.

Position the handle in the center of the plywood and fasten together with glue and woodscrews.

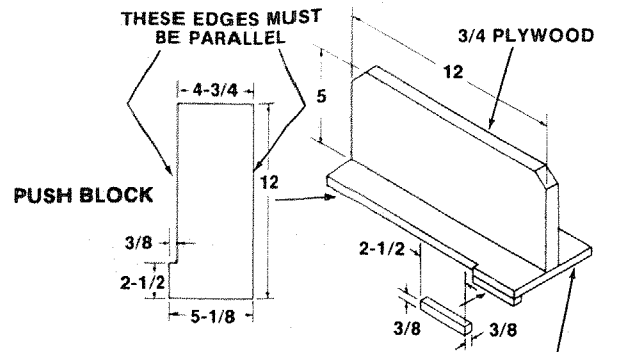

NOTE: All dimensions in inches 3/8 PLYWOOD

AUXILIARY FENCE/WORK SUPPORT

Make one using a piece of 3/8 in. and 3/4 in. plywood. Fasten together with glue and woodscrews.

NOTE: Since the Push Block is used with the Auxiliary Fence, the 4-3/4 in. dimensions must be held identical on both the pieces.

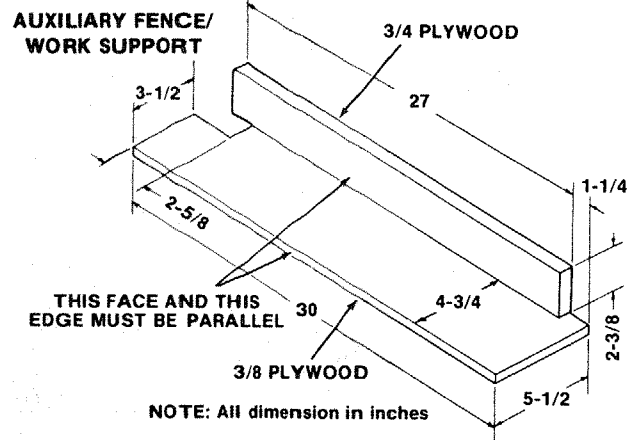

NOTE: All dimension in inches

USING THE MITER GAUGE

THE MITER GAUGE IS USED WHEN CROSSCUTTING, MITER CUTTING, BEVEL CUTTING, COMPOUND MITER CUTTING, DADOING and when RABBETTING AND MOLDING across the end of a narrow workpiece.

WARNING: FOR YOUR OWN SAFETY, ALWAYS OBSERVE THE FOLLOWING SAFETY PRECAUTIONS IN ADDITION TO THE SAFETY INSTRUCTIONS ON PAGES 2, 3, and 4.

1. Never make these cuts freehand (without using the miter gauge or other auxiliary devices) because the blade could bind in the cut and cause a KICKBACK or cause your fingers or hand to slip into the blade.
2. Always lock the miter gauge securely when in use.
3. Remove rip fence from table.
4. Make sure blade guard is installed for all "thru-sawing" operations (when sawblade cuts entirely thru the thickness of the workpiece.) Replace guard IMMEDIATELY after completion of dadoing, molding or rabbeting cuts.
5. Have blade extend approximately 1/8 in. above top of workpiece. Additional blade exposure would increase the hazard potential.

6. Do not stand directly in front of the blade in case of a THROWBACK (Small cut-off piece caught by the back of the blade and thrown toward the operator). Stand to either side of the blade.
7. Keep your hands clear of the blade and out of the path of the blade.
8. If blade stalls or stops while cutting, TURN SWITCH OFF before attempting to free the blade.
9. Do not reach over or behind the blade to pull the workpiece through the cut... to support long or heavy workpieces... to remove cut-off pieces of material or FOR ANY OTHER REASON.
10. Do not pick up small pieces of cut-off material from the table. REMOVE them by pushing them OFF the table with a long stick. Otherwise they could be thrown back at you by the rear of the blade.
11. Do not remove small pieces of cut-off material that may become TRAPPED inside the blade guard while the saw is RUNNING. THIS COULD ENDANGER YOUR HANDS or cause a KICKBACK.

Turn the saw OFF. After the blade has stopped turning, lift the guard and remove the piece.

CROSSCUTTING

CROSSCUTTING is known as cutting wood across the grain, at 90°, or square with both the edge and the flat side of the wood. This is done with miter gauge set at "0".

The graduations on the miter gauge provide accuracy for average woodworking. In some cases where extreme accuracy is required, when making angle cuts, for example, make a trial cut and then recheck it with an accurate square, or protractor.

If necessary, the miter gauge head can be swiveled slightly to compensate for any inaccuracy.

NOTE: The space between the miter gauge bar and the groove in the table is held to a minimum during manufacturing.

For maximum accuracy when using the miter gauge, always "favor" one side of the groove in the table. In other words, don't move the miter gauge from side to side while cutting, but keep one side of the bar riding against one side of the groove.

NOTE: Glue a piece of sandpaper to the face of the miter gauge head. This will help prevent the workpiece from "creeping" while it is being cut.

The Hold-Down Clamp (Optional Accessory) should be used on the miter gauge for greater accuracy.

The miter gauge may be used in either of the grooves in the table. Make sure it is locked.

When using the miter gauge in the LEFT hand

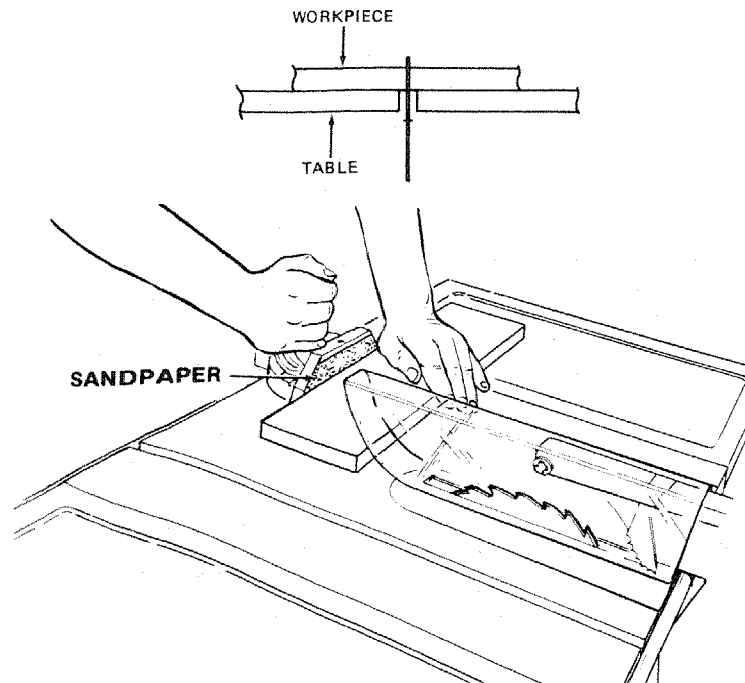

groove, hold the workpiece firmly against the miter gauge head with your left hand, and grip the lock handle with your right.

When using the RIGHT Hand groove, hold the workpiece with your right hand and the lock handle with your left hand.

When cutting long workpieces, invert AUXILIARY FENCE/WORK SUPPORT and position it on top of the guide bars to support the workpieces as near to the end as possible. If this does not adequately support the workpiece, you can make a simple support by clamping a piece of plywood to a sawhorse.

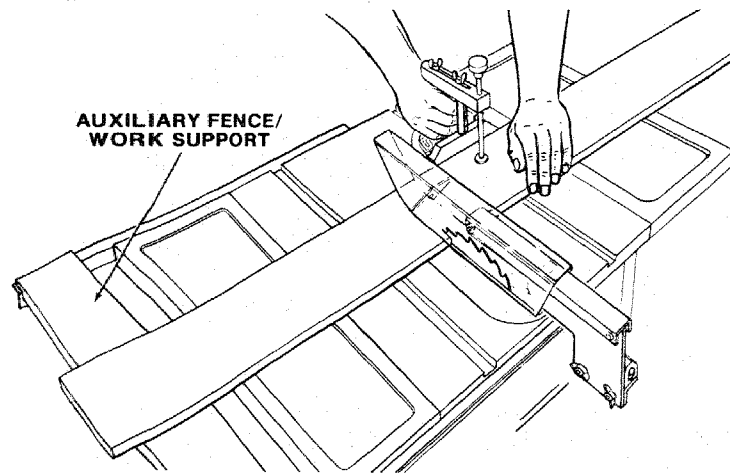

REPETITIVE CUTTING

REPETITIVE CUTTING is known as cutting a quantity of pieces the same length without having to mark each piece.

1. Use the Stop Rods (optional accessory) only for cutting duplicate pieces 6 in. long and longer.
2. DO NOT FEED workpiece with RIGHT Hand, merely guide it, making sure that it does not bind or pinch the sawblade.

When making repetitive cuts from a long workpiece, make sure it is adequately supported.

Use the Hold-Down Clamp (Optional Accessory) on the miter gauge for greater accuracy.

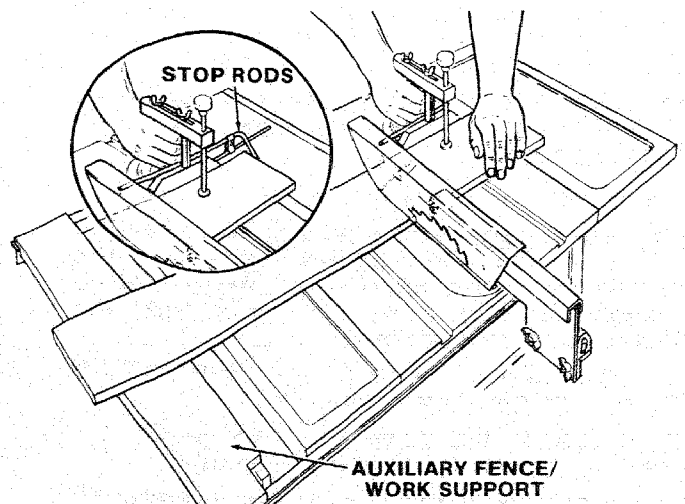

1. NEVER USE THE RIP FENCE AS A LENGTH STOP BECAUSE THE CUTOFF PIECE COULD BIND BETWEEN THE FENCE AND THE BLADE CAUSING A KICKBACK.
2. When making repetitive cuts shorter than 6 in., clamp a block of wood 2 in. long to the table to act as a length stop. Do not clamp directly to the bottom edge of the table because the "swivel" of the clamp will not grip properly. Place a small block of wood between the bottom edge of the table and the "C" clamp.

CAUTION: When clamping the block, make sure that the end of the block is well in front of the sawblade. Be sure it is clamped securely.

3. Slide the workpiece along the miter gauge until it touches the block . . . hold it securely or clamp it with the Hold-Down Clamp (Optional Accessory).
4. Make the cut . . . pull the workpiece back . . . push the cut off piece off the table with a long push

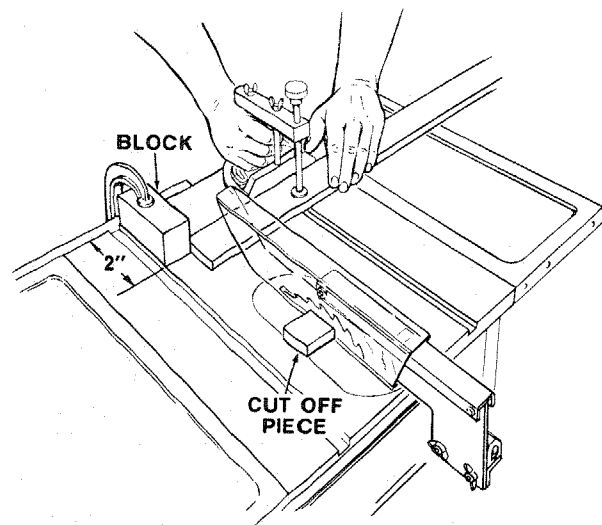

stick . . . DO NOT ATTEMPT TO PICK IT UP AS THIS COULD ENDANGER YOUR HANDS.

MITER CUTTING

MITER CUTTING is known as cutting wood at an angle other than 90° with the edge of the wood. Follow the same procedure as you would for crosscutting.

Adjust the miter gauge to the desired angle, and lock it.

The miter gauge may be used in either of the grooves in the table.

When using the miter gauge in the LEFT Hand groove, hold the workpiece firmly against the miter gauge head with your left hand, and grip the lock knob with your right.

When using the RIGHT hand groove, hold the workpiece with your right hand and the knob with your left hand.

Use the Hold-Down Clamp (Optional Accessory) on the miter gauge for greater accuracy.

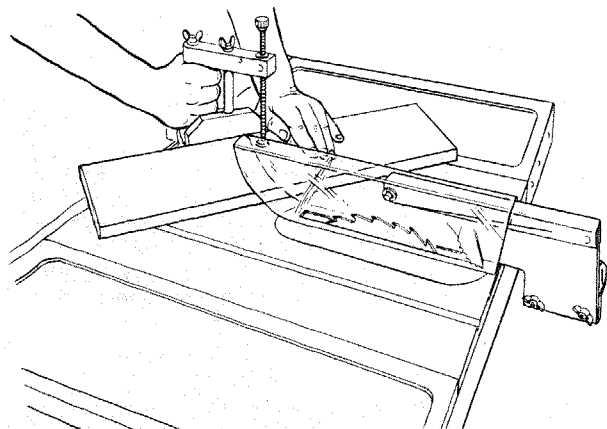
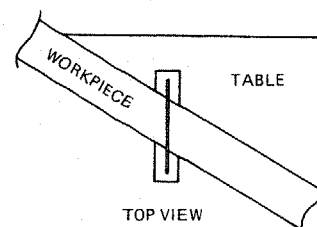

BEVEL CROSSCUTTING

BEVEL CROSSCUTTING is the same as crosscutting except that the wood is also cut at an angle . . . other than 90° with the flat side of the wood.

Lower blade to about 2 inches above the table top before tilting blade. Failure to do this may result in damage to your saw.

Adjust the blade to the desired angle.

Use the Miter Gauge in the groove to the RIGHT of the blade. It cannot be used in the groove to the LEFT because the blade guard will interfere. Hold the workpiece with your right hand and the lockhandle with your left hand.

Use the AUXILIARY FENCE/WORK SUPPORT for additional support of the workpiece.

Lay it across the guide bars to support the workpiece as near to the end as possible.

Use the Hold-Down Clamp (Optional Accessory) on the miter gauge for greater accuracy.

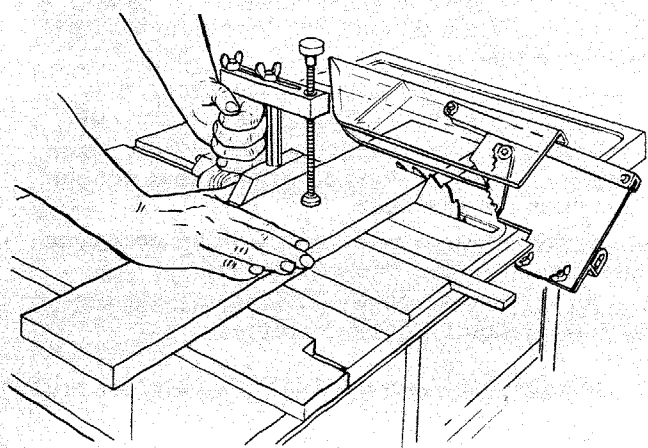
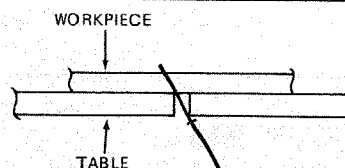

COMPOUND MITER CUTTING

COMPOUND MITER CUTTING is a combination of miter cutting and bevel crosscutting. The cut is

made at an angle other than 90° to both the edge and the flat side of the wood.

Adjust the miter gauge and the blade to the desired angle . . . Make sure miter gauge is locked.

USING THE RIP FENCE

RIPPING, BEVEL RIPPING, PLOUGHING, MOLDING, RESAWING AND RABBETING are performed using the RIP FENCE together with the AUXILIARY FENCE/WORK SUPPORT, PUSH STICK OR PUSH BLOCK.

WARNING: FOR YOUR OWN SAFETY, ALWAYS OBSERVE THE FOLLOWING SAFETY PRECAUTIONS IN ADDITION TO THE SAFETY INSTRUCTIONS ON PAGES 2, 3, and 4.

1. Never make these cuts FREEHAND (without using the rip fence or auxiliary devices when required) because the blade could bind in the cut and cause a KICKBACK.
2. Always lock the rip fence securely when in use.
3. Remove miter gauge from table.
4. Make sure blade guard is installed for all thru-sawing type cuts. Replace the guard IMMEDIATELY following completion of resawing, rabbeting, dadoing, or molding operations.

Frequently check the action of the ANTICKICKBACK PAWLS by passing the workpiece alongside of the spreader while saw is OFF.

Pull the workpiece TOWARD you. If the PAWLS do not DIG into the workpiece and HOLD it . . . the pawls must be SHARPENED. See "Maintenance" section.

5. Have blade extend approximately 1/8 in. above top of workpiece. Additional blade exposure would increase the hazard potential.
6. Do not stand directly in front of the blade in case of a KICKBACK. Stand to either side of the blade.
7. Keep your hands clear of the blade and out of the path of the blade.
8. If the blade stalls or stops while cutting. TURN SWITCH OFF before attempting to free the blade.
9. Do not reach over or behind the blade to pull the workpiece through the cut . . . to support long or heavy workpieces . . . to remove small cut-off pieces of material or FOR ANY OTHER REASON.
10. Do not pick up small pieces of cut-off material from the table. REMOVE them by pushing them OFF the table with a long stick. Otherwise they could be thrown back at you by the rear of the blade.
11. Do not remove small pieces of cut-off material that may become TRAPPED inside the blade guard while the saw is RUNNING. THIS COULD ENDANGER YOUR HANDS or cause a KICKBACK.
Turn the saw OFF. After the blade has stopped turning, lift the guard and remove the piece.

RIPPING

RIPPING is known as cutting a piece of wood with the grain, or lengthwise. This is done using the rip fence.

Position the fence to the desired WIDTH OF RIP and lock in place.

Before starting to rip, be sure

- A. Rip Fence is parallel to sawblade.
- B. Spreader is properly aligned with sawblade.
- C. Antikickback pawls are functioning properly.

When ripping LONG BOARDS or LARGE PANELS, always use a work support.

A simple one can be made by clamping a piece of plywood to a sawhorse.

BEVEL RIPPING

When bevel ripping material 6 in. or narrower, use fence on the right side of the blade ONLY. This will provide more space between the fence and the sawblade for use of a push stick. If the fence is mounted to the left, the sawblade guard may interfere with proper use of a push stick.

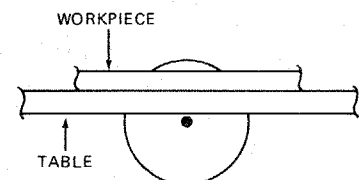

ALWAYS SUPPORT LONG WORKPIECES

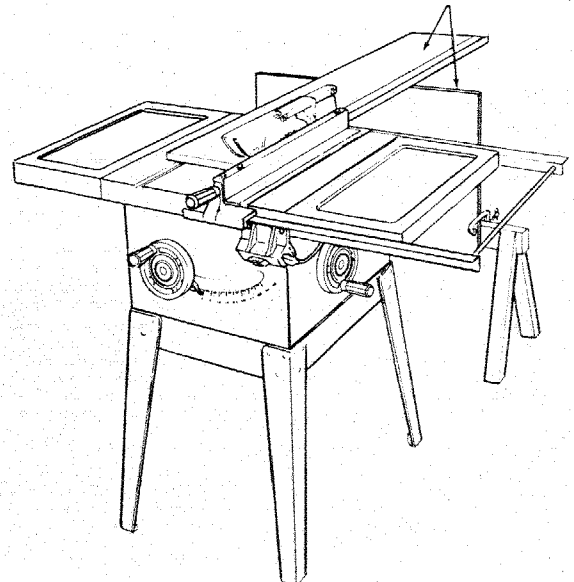

When "WIDTH OF RIP" is 6 in. and WIDER use your RIGHT Hand to feed the workpiece until it is clear of the table.

Use LEFT hand ONLY to guide the workpiece ... do not FEED the workpiece with the left hand.

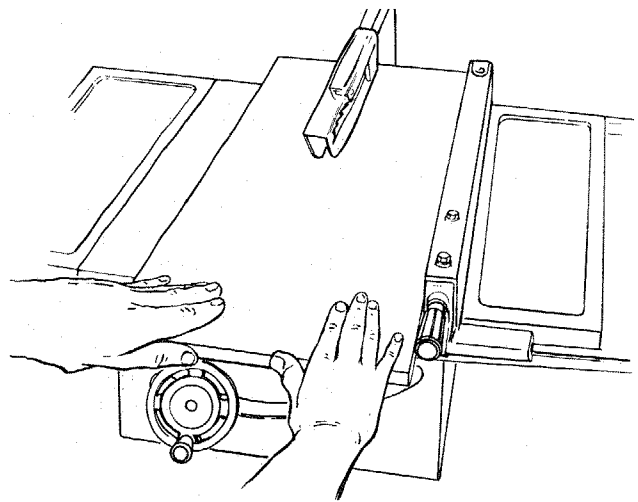

When "WIDTH OF RIP" is 2 in. to 6 in. wide USE THE PUSH STICK to feed the work.

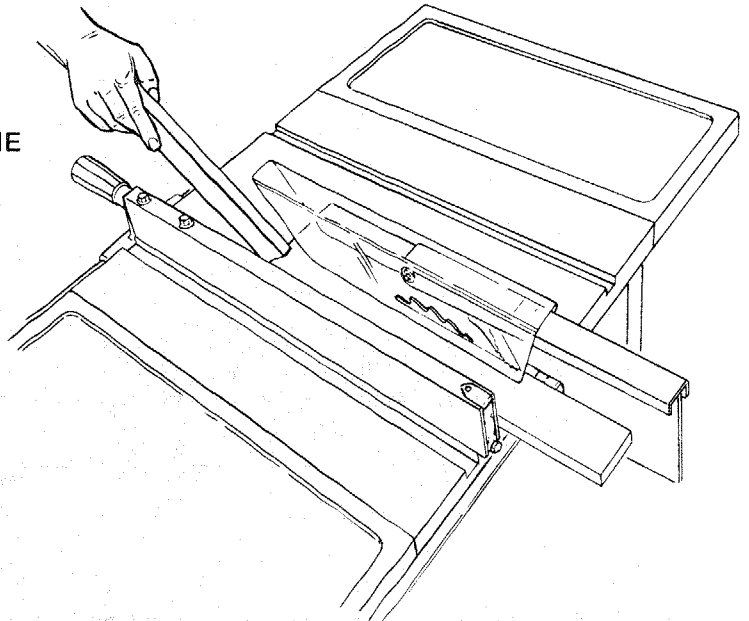

When WIDTH OF RIP is NARROWER than 2 in., the push stick CANNOT be used because the guard will interfere ... USE the AUXILIARY FENCE/WORK SUPPORT and PUSH BLOCK.

Attach Auxiliary Fence/Work Support to rip fence with two "C" clamps.

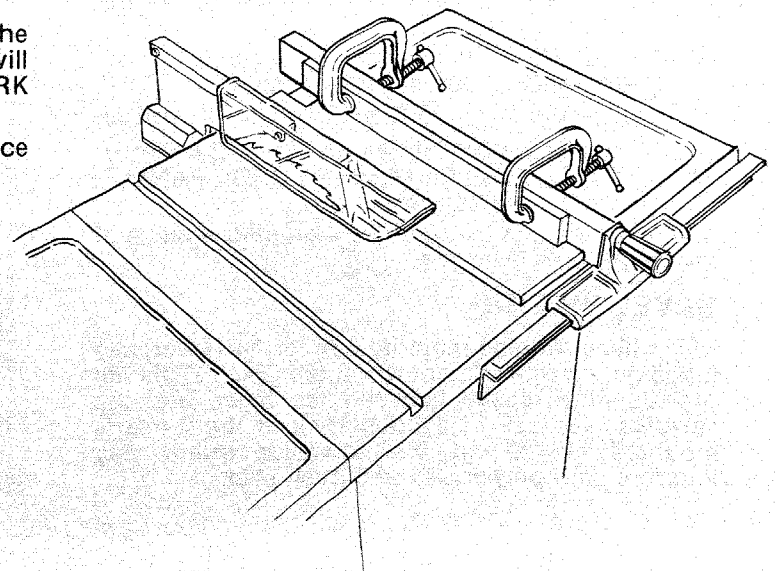

Feed the workpiece by hand along the AUXILIARY FENCE until the end is approx. 1 in. past the front edge of the table. Continue to feed using the PUSH BLOCK.

Hold the workpiece in position and install the PUSH BLOCK by sliding it on top of the AUXILIARY FENCE/WORK SUPPORT (This May Raise Guard).

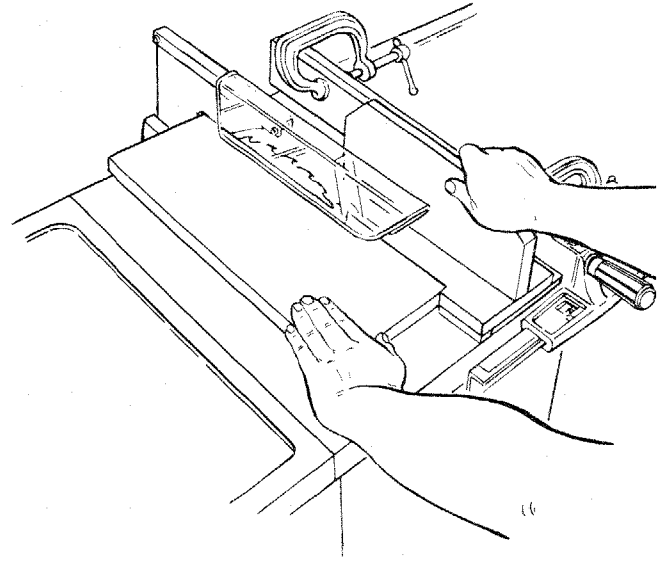

Narrow strips thicker than the Auxiliary Fence/Work Support may enter the guard and strike the baffle. CAREFULLY raise guard only enough to clear the workpiece. Use PUSH BLOCK to complete cut.

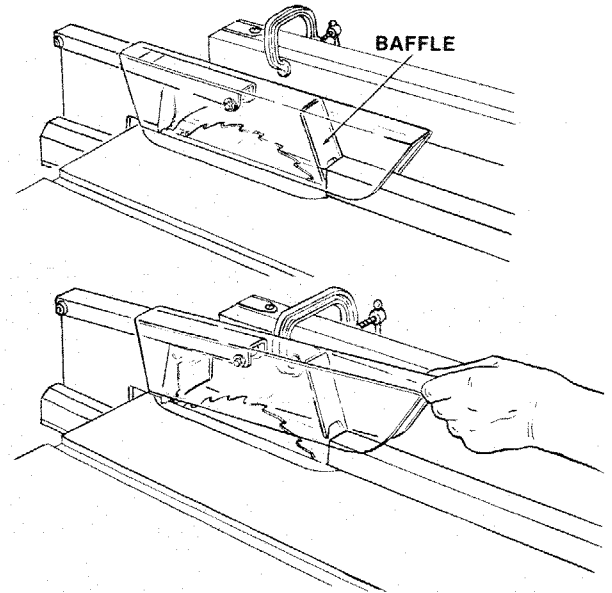

CUTTING PANELS

When cutting panels (whenever fence is positioned outside of table surface), ALWAYS use the AUXILIARY FENCE/WORK SUPPORT.

1. Unlock fence and raise rear end.
2. Position AUXILIARY FENCE/WORK SUPPORT as shown and attach it with two "C" clamps.

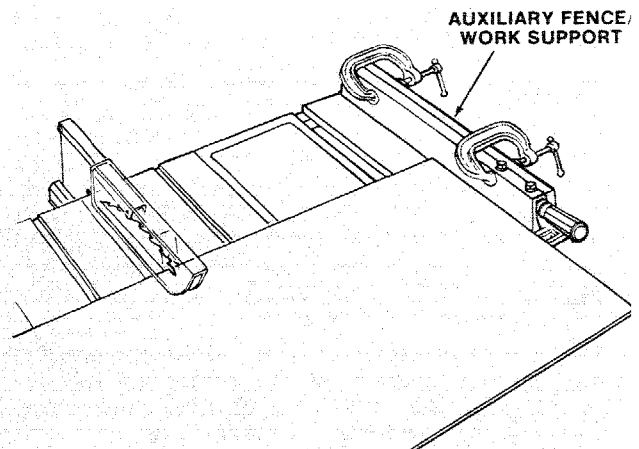

PLOUGHING AND MOLDING

PLOUGHING is grooving with the grain the long way of the workpiece, using the fence. USE proper holddowns and feed devices.

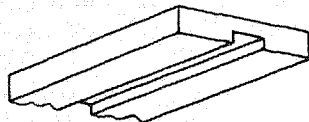

PLOUGHING

MOLDING is shaping the workpiece with the grain the long way of the workpiece, using the fence. Use proper holddowns and feed devices.

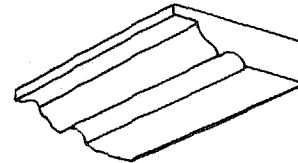

MOLDING

RESAWING

RESAWING is a "thru-sawing" cut made by ripping a piece of wood through its thickness. Do not attempt to resaw BOWED or WARPED material. NOTE: To RESAW a piece of wood wider than 3-3/8 in. . . . it will be necessary to remove the blade guard and use the AUXILIARY FENCE/WORK SUPPORT. (See "Work Helpers").

Clamp it to the table so that the workpiece will SLIDE EASILY but not TILT or MOVE SIDWAYS between the two fences.

Do not clamp directly to the bottom edge of the table because the "swivel" of the clamp will not grip properly. Place a small block of wood between the bottom edge of the table and the "C" clamp.

WARNING: FOR YOUR OWN SAFETY . . .

1. DO NOT "BACK UP" (REVERSE FEEDING) WHILE RESAWING BECAUSE THIS COULD CAUSE A KICKBACK.

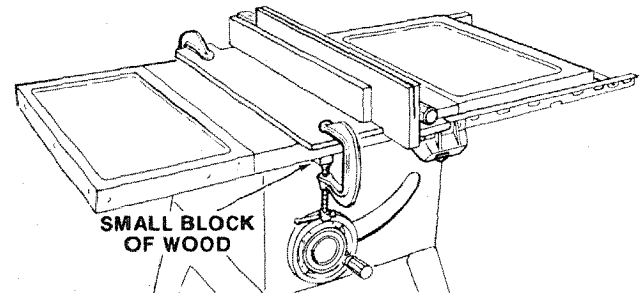

2. MAKE FIRST PASS TO A DEPTH SLIGHTLY LESS THAN ONE-HALF THE WIDTH OF THE BOARD; KEEP SAME FACE OF BOARD AGAINST FENCE FOR SECOND PASS AS THE FIRST PASS.
3. INSTALL BLADE GUARD IMMEDIATELY UPON COMPLETION OF THE RESAWING OPERATION.

RABBETING

RABBETING is known as cutting out a section of the corner of a piece of material, across an end or along an edge.

To make a RABBET requires cuts which do not go all the way through the material. Therefore the blade guard must be removed.

1. Remove blade guard. Use caution. Use featherboards and push sticks, etc. as required.
2. For rabbeting along an edge (long way of workpiece) as shown, add facing to rip fence approximately as high as the workpiece is wide. Adjust rip fence and blade to required dimensions; then make first cut with board flat on table as any rip (type) cut; make second cut with workpiece on edge. Follow all precautions, safety instructions, and operational instructions as for ripping, or rip type operations, including feather boards and push stick, etc.
3. For rabbeting across an end, for workpiece 10-1/2" and narrower make the rabbet cut with the board flat on the table using the miter gauge fitted with a facing. DO NOT use the rip fence.

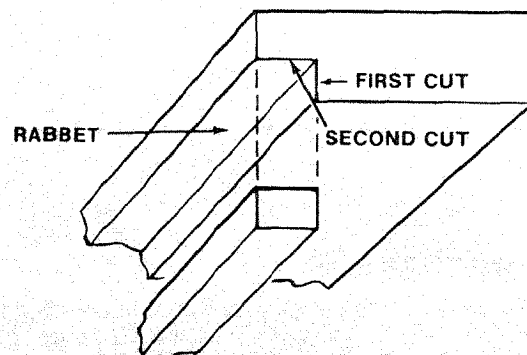

WARNING: FOR YOUR OWN SAFETY, INSTALL BLADE GUARD IMMEDIATELY UPON COMPLETION OF RABBETING OPERATION.

Rabbet cuts can also be made using the dado head or molding head.

DADOING

Instructions for operating the Dado Head are contained in booklet furnished with the Dado Head. The Recommended Dado Head is listed under Recommended Accessories in this manual.

The arbor on the saw, is only long enough so that the widest cut that can be made is 13/16" wide.

It is not necessary to install the outside loose collar before screwing on the arbor nut. Make sure the arbor nut is tight.

ALWAYS USE DADO INSERT LISTED UNDER RECOMMENDED ACCESSORIES.

When using the dado head it will be necessary to remove the Blade Guard and Spreader. **USE CAUTION. USE FEATHERBOARDS AND PUSH STICKS AS REQUIRED.**

WARNING: FOR YOUR OWN SAFETY, ALWAYS REPLACE THE BLADE GUARD AND SPREADER WHEN YOU ARE FINISHED DADOING.

MOLDING CUTTING

Instructions for operating the Molding Head are contained in a booklet furnished with the Molding Head.

The recommended molding head is listed under Recommended Accessories in this manual.

Always use Molding Insert Listed Under Recommended Accessories.

When using the molding head it will be necessary to remove the Blade Guard and Spreader. **USE**

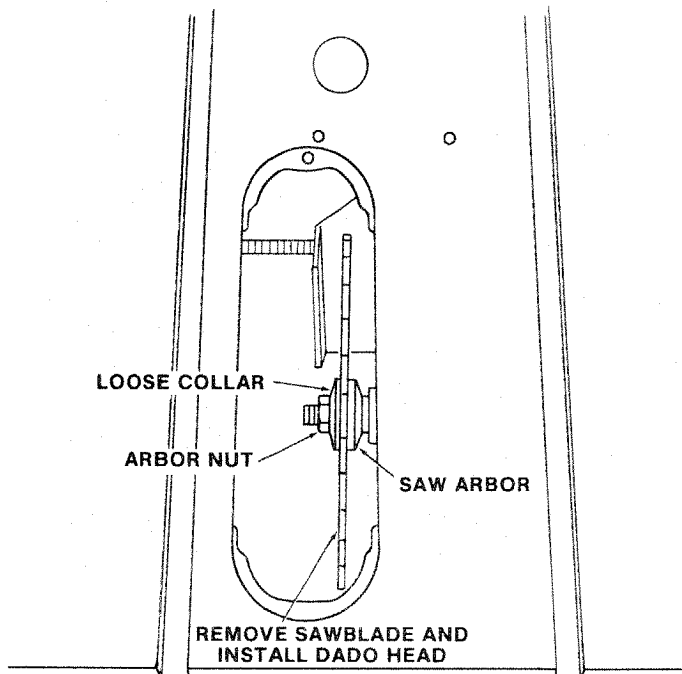

CAUTION. USE FEATHERBOARDS AND PUSH STICKS, etc. AS REQUIRED.

WARNING: FOR YOUR OWN SAFETY, ALWAYS REPLACE THE BLADE GUARD AND SPREADER WHEN YOU ARE FINISHED MOLDING.

USING FEATHERBOARDS

Featherboards are **not** employed during non thru-sawing operations when using the miter gauge.

Use featherboards for all other non "thru-sawing" operations (when sawblade guard must be removed). Featherboards are used to keep the work in contact with the fence and table as shown, and to stop kickbacks.

Add 8 inch high flat facing board to the fence, the full length of the fence.

Mount featherboards to fence and table as shown, so that leading edges of featherboards will support workpiece until cut is complete, and the workpiece

has been pushed completely past the cutter (sawblade, dado head, molding head, etc.) with a pushstick, as in ripping.

Before starting the operation (switch "OFF" and cutter below table surface):

- Install featherboards so they exert pressure on the workpiece; be positive they are secure, and
- Make sure by trial that the featherboards will stop a kickback if one should occur.

Replace the sawblade guard as soon as the non thru-sawing operation is complete.

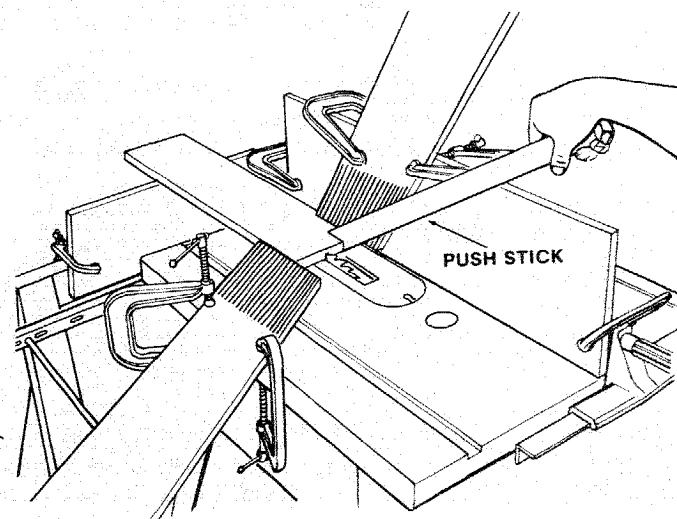
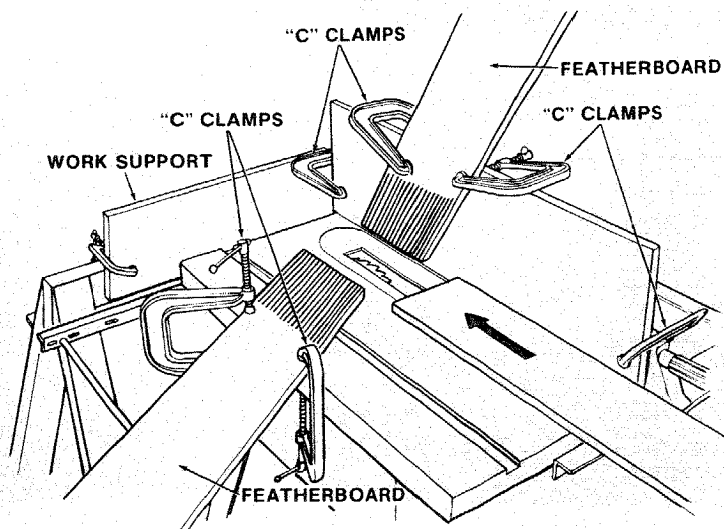

MOTOR

LUBRICATION AND MAINTENANCE

1. The sleeve bearings, in both end shields of the motor, have been lubricated at the factory with correct lubricant. No other part of the motor requires lubrication.
2. Re-lubricate motor bearings in accordance with the instructions on the nameplate. Be sure to wipe off dirt or grit if present around oil hole caps to prevent any possibility of foreign material contaminating the oil wicks that supply the bearings with oil. Use a good grade of medium weight mineral oil, such as automobile engine oil, SAE 20.
3. If disassembly of the motor is necessary, it should be returned to your nearest Sears retail or mail-order store in order to prevent voiding the guarantee.

NOTE: The speed of this motor cannot be regulated or changed.

4. Every effort should be made to prevent foreign material from entering the motor. When operated under conditions likely to permit accumulations of dust, dirt, or waste within the motor, a visual inspection should be made at frequent intervals. Accumulations of dry dust can usually be blown out successfully.

NOTE: Motors used on wood-working tools are particularly susceptible to the accumulation of sawdust and wood chips and should be blown out or "vacuumed" frequently to prevent interference with normal motor ventilation and proper operation of the centrifugally-operated starting switch.

MAINTENANCE

WARNING: TO AVOID INJURY, TURN SWITCH "OFF" AND REMOVE PLUG FROM POWER SOURCE OUTLET BEFORE MAINTAINING OR LUBRICATING YOUR SAW.

Do not allow sawdust to accumulate inside the saw. Frequently blow out any dust that may accumulate inside the saw cabinet and the motor.

Frequently clean your cutting tools with Craftsman Gum and Pitch Remover.

A coat of automobile-type wax applied to the table will help to keep the surface clean and allow workpieces to slide more freely.

If the power cord is worn or cut, or damaged in any way, have it replaced immediately.

Make sure the teeth of the ANTIKICKBACK pawls are always sharp. To sharpen:

1. Identify the dull tooth or teeth. Remove blade guard.
2. Rotate pawl toward rear of spreader so that teeth are above top of spreader.
3. Hold spreader with left hand and place pawl over corner of workbench.
4. Sharpen the dull tooth using a few light strokes of a fine-cut round file.

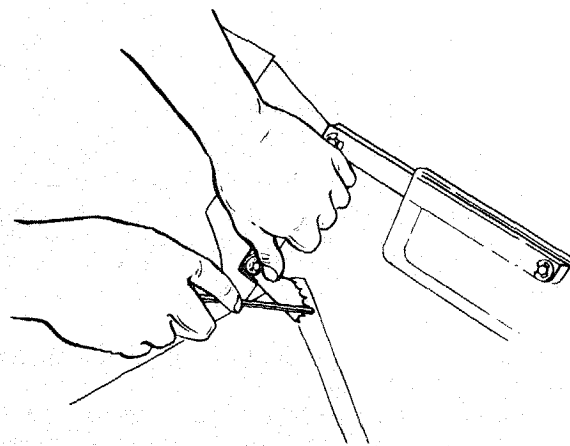

LUBRICATION

The following parts should be oiled occasionally with SAE No. 20 or No. 30 engine oil.

1. Tilt screw threads and pivot nut. (First Clean with Craftsman Gum & Pitch Remover.)
2. Elevation screw threads and pivot nut. (First Clean with Craftsman Gum & Pitch Remover.)
3. Cradle bearing points.
4. Bearing points in guard assembly, miter gauge and rip fence.

LUBRICATION OF FLEXIBLE SHAFT

Flexible shafts do require periodic lubrication because the core acts as a screw conveyor which will pump the lubrication to one end of the shaft over an extended period of operation. The frequency of lubrication depends on how the saw is used. When the saw operates continuously for long periods of time, a lubrication schedule should be developed. The time period may be every 80 or 100 hours. An indication that the shaft needs lubrication is when it becomes noisy. Conversely, when the saw has limited and infrequent use, the grease will

eventually age and harden so that it will not provide an adequate oil film between the core and casing liner and must be replaced.

LUBRICATION PROCEDURES

1. Remove the core from the casing, clean the core by washing with kerosene or an approved solvent.
2. Dry the core.
3. Inspect the core for worn or broken wires. If core is damaged, it should be replaced.
4. "Butter" the entire length of the core with a good grade of general purpose bearing grease with a minimum operating temperature of -40° F and reassemble in casing. DO NOT force the grease into the casing with a grease gun. Too much grease will affect shaft life because it makes the core work harder.

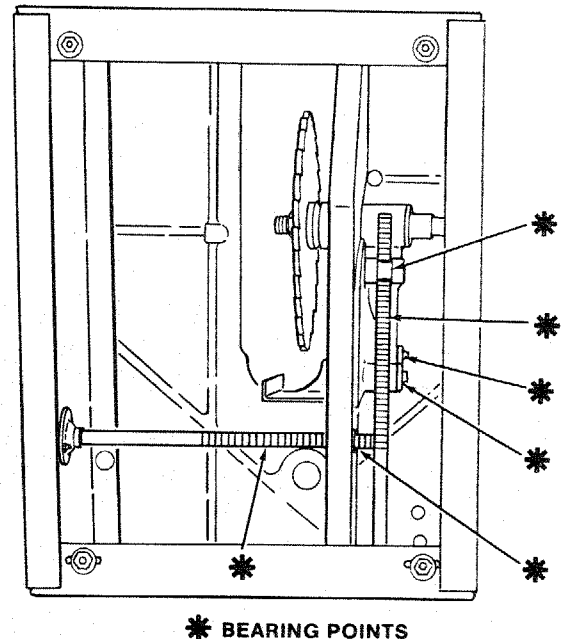
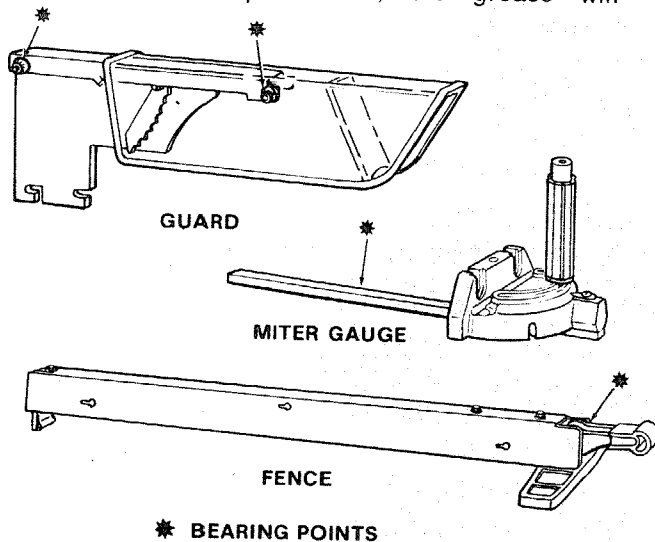

RECOMMENDED ACCESSORIES

ITEM	CAT. NO.
Steel Stand	9-22214
Caster Sets	9-22222 or 9-22221
Solid Table Extension	9-29957
7 In. Molding Head Set	9-3217
7 In. Molding Head Set	9-3218
7 In. Molding Head	9-3214
Molding/Dado Insert for 7 in. Dia. Molding or Dado Head	9-22271
Work Light	9-2480
Sawdust Collection System	9-24242
10" Dia. Sawblades with 5/8" Bore .	See Catalog
Work Light	9-2481

ITEM	CAT. NO.
7 In. Dia. Adjustable Dado Head	9-3261 - 9-3262 - 9-3263
7 In. Dia. Dado Head	9-3257
Sanding Wheel	9-22723
Miter-Gauge Stop Rods	9-29924
Miter-Gauge Hold-Down Clamp	9-29928
Taper Jig	9-3233
Universal Jig	9-3235
Powe Tool Know How Handbook	
Table Saw	9-2918
Cast Iron Extension, 12 x 27 Inches	9-22261
Rip Fence Bar	9-29969
Table Extension Kit	9-29968

TROUBLE SHOOTING

WARNING: TO AVOID INJURY, TURN SWITCH "OFF" AND ALWAYS REMOVE PLUG FROM POWER SOURCE OUTLET BEFORE TROUBLESHOOTING.

TROUBLE SHOOTING -- GENERAL

TROUBLE	PROBABLE CAUSE	REMEDY
Excessive vibration.	1. Blade out of balance.	1. Discard Blade and use a different blade.
Cannot make square Cut when crosscutting.	1. Miter gauge not adjusted properly.	1. See "Adjusting Miter Gauge."
Cut binds, burns or stalls motor when ripping.	1. Dull blade with improper tooth set. 2. Blade is Heeling. 3. Warped board. 4. Rip fence not parallel to blade. 5. Spreader out of alignment.	1. Sharpen or replace blade. 2. See "Heeling Adjustment . . ." 3. Make sure concave or hollow side is facing "down," feed slowly. 4. See "Aligning Rip Fence" 5. See "Aligning Spreader."
Cut not true at 90° or 45° positions.	1. Stop screws not properly adjusted.	1. See "Blade Tilt", or "Squareness of Blade to Table."
Tilt and elevating handwheel turn hard.	1. Sawdust on threads of tilt screw or elevating screw. 2. Bearing retainers too tight.	1. See "Maintenance and Lubrication" section. 2. See "Tilt Mechanism."

TROUBLE SHOOTING -- MOTOR

NOTE: Motors used on wood-working tools are particularly susceptible to the accumulation of sawdust and wood chips and should be blown out or "vacuumed" frequently to prevent interference with normal motor ventilation.

TROUBLE	PROBABLE CAUSE	REMEDY
Excessive noise.	1. Motor.	1. Have motor checked by qualified service technician. Repair service is available at your nearest Sears store.
Motor fails to develop full power. NOTE: LOW VOLTAGE: (Power output of motor decreases rapidly with decrease in voltage at motor terminals. For example, a reduction of 10% in voltage causes a reduction of 19% in maximum power output of which the motor is capable, and a reduction of 20% in voltage causes a reduction of 36% in maximum power output.)	1. Circuit overloaded with lights, appliances and other motors. 2. Undersize wires or circuit too long. 3. General overloading of power company facilities.	1. Do not use other appliances or motors on same circuit when using the saw. 2. Increase wire sizes, or reduce length of wiring. See "Motor Specification and Electrical Requirements" section. 3. Request a voltage check from the power company.

TROUBLE SHOOTING -- MOTOR (Continued)

TROUBLE	PROBABLE CAUSE	REMEDY
Motor starts slowly or fails to come up to full speed.	<ol style="list-style-type: none"> 1. Low voltage will not trip relay. 2. Windings burned out or open. 3. Starting relay not operating. 	<ol style="list-style-type: none"> 1. Request voltage check from the power company. 2. Have motor repaired or replaced. 3. Have relay replaced.
Motor overheats.	<ol style="list-style-type: none"> 1. Motor overloaded. 2. Improper cooling. (Air circulation restricted through motor due to sawdust. 	<ol style="list-style-type: none"> 1. Feed work slower into blade. 2. Clean out sawdust to provide normal air circulation through motor. See "Maintenance and Lubrication" section.
Starting switch in motor will not operate.	<ol style="list-style-type: none"> 1. Burned switch contacts (due to extended hold-in periods caused by low line voltage, etc.) 2. Shorted capacitor 3. Loose or broken connections. 	<ol style="list-style-type: none"> 1. Have switch replaced and request a voltage check from the power company. 2. Have capacitor tested and replace if defective. 3. Have wiring checked and repaired.
Motor stalls (resulting in blown fuses or tripped circuit breakers).	<ol style="list-style-type: none"> 1. Starting switch not operating. 2. Voltage too low to permit motor to reach operating speed. 3. Fuses or circuit breakers do not have sufficient capacity. 	<ol style="list-style-type: none"> 1. Have switch replaced. 2. Request voltage check from the power company. 3. Install proper size fuses or circuit breakers.
Frequent opening of fuses or circuit breakers.	<ol style="list-style-type: none"> 1. Motor overloaded. 2. Fuses or circuit breakers do not have sufficient capacity. 3. Starting switch not operating (motor does not reach speed). 	<ol style="list-style-type: none"> 1. Feed work slower into blade. 2. Install proper size fuses or circuit breakers. 3. Have switch replaced.

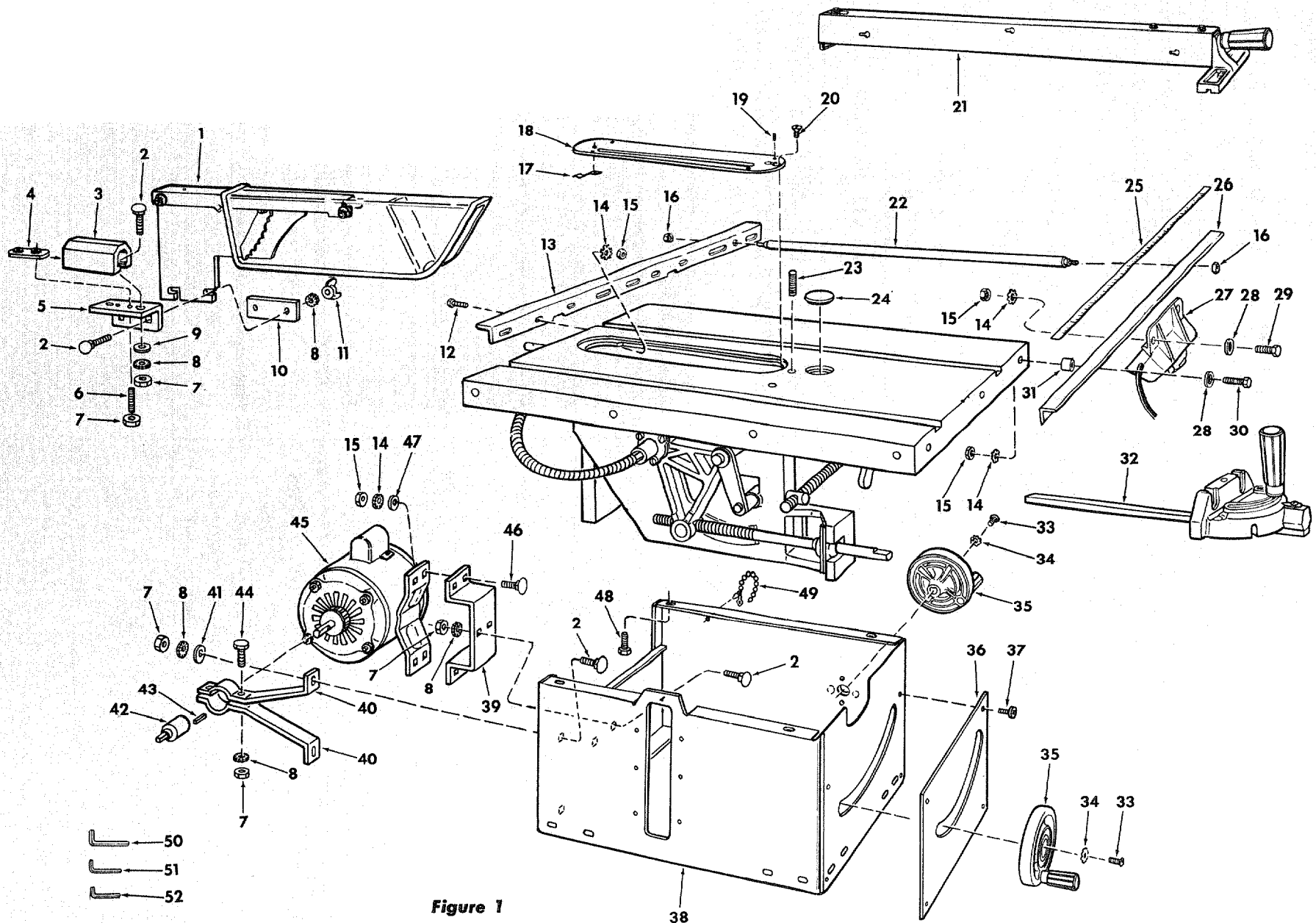

Figure 1

- 50
- 51
- 52

PARTS LIST FOR CRAFTSMAN 10 INCH TABLE SAW MODEL NO. 113.241680

FIGURE 1

Key No.	Part No.	Description
1	62894	Guard Assembly, Saw (See Fig. 5)
2	STD532507	*Bolt, Carriage 1/4-20 x 3/4
3	62886	Support, Spreader
4	60538	Nut, Twin
5	62863	Bracket, Spreader
6	STD502505	*Screw, Hex Soc. Set 1/4-20 x 1
7	STD541025	*Nut, Hex 1/4-20
8	STD551225	*Lockwasher, External 1/4
9	9414920	Washer, 17/64 x 5/8 x 1/32
10	62866	Clamp, Spreader
11	STD541625	*Nut, Wing 1/4-20
12	STD523110	*Screw, Hex Hd. 5/16-18 x 1
13	62541	Bar, Fence Rear
14	STD551131	*Lockwasher, External 5/16
15	STD541031	*Nut, Hex Jam 5/16-18
16	60388	Nut, Self Threading
17	62718	Clip, Retaining
18	62873	Insert Assembly (Includes Key Nos. 16 & 18)
19	STD501102	*Screw, Locking Set 10-32 x 3/16
20	133645	Screw, Flat Cross 10-32 x 1
21	62773	Fence Assembly, Rip (See Fig. 3)
22	62748	Rod, Separation (Includes Key #15)
23	60534	Screw, Hex Soc. Set 5/16-18 x 1
24	62493	Insert, Exact-I-Cut
25	62710	Tape, Fence
26	62709	Bar Assembly, Fence Guide (Includes Key #24)
27	60381	Outlet, On/Off Power (See Fig. 6)
28	STD551031	*Washer, 21/64 x 5/8 x 1/16

Key No.	Part No.	Description
29	STD523107	*Screw, Hex Hd. 5/16-18 x 5/8
30	STD523117	*Screw, Hex Hd. 5/16-18 x 1-3/4
31	62539	Spacer, Fence Guide Bar
32	62704	Gauge Assembly, Miter (See Fig. 4)
33	STD511107	*Screw, Pan Cross 10-32 x 3/4
34	STD551210	*Lockwasher, External No. 10
35	62689	Handwheel Assembly
36	62888	Trim, Front
37	9426307	Screw, Pan Cross Type "T" No. 8 x 1/2
38	62892	Base Assembly
39	62875	Mount, Motor
40	62864	Bracket, Shaft
41	446188	Washer, 17/64 x 3/4 x 1/16
42	62867	Connector, Motor (Includes Key #43)
43	803744-1	Key, 3/16 Square x 5/8
44	STD522510	*Screw, Hex Hd. 1/4-20 x 1
45	62855	Motor (See Fig. 9)
46	STD533107	*Bolt, Carriage 5/16-18 x 3/4
47	60465	Washer, 21/64 x 47/64 x 1/16
48	423567	Screw, Sems 3/8-16 x 1/2
49	71165	Tie, Wire
50	37837	Wrench Hex "L" 5/32
51	37887	Wrench Hex "L" 1/8
52	37836	Wrench Hex "L" 3/32
	62868	Owners Manual (Not Illustrated)
	62889	Bag of Loose Parts (Not Illustrated)
	62890	Bag of Loose Parts (Not Illustrated)
	62891	Bag of Loose Parts (Not Illustrated)

* Standard Hardware Item — May Be Purchased Locally.

PARTS LIST FOR CRAFTSMAN 10 INCH TABLE SAW MODEL NO. 113.241680

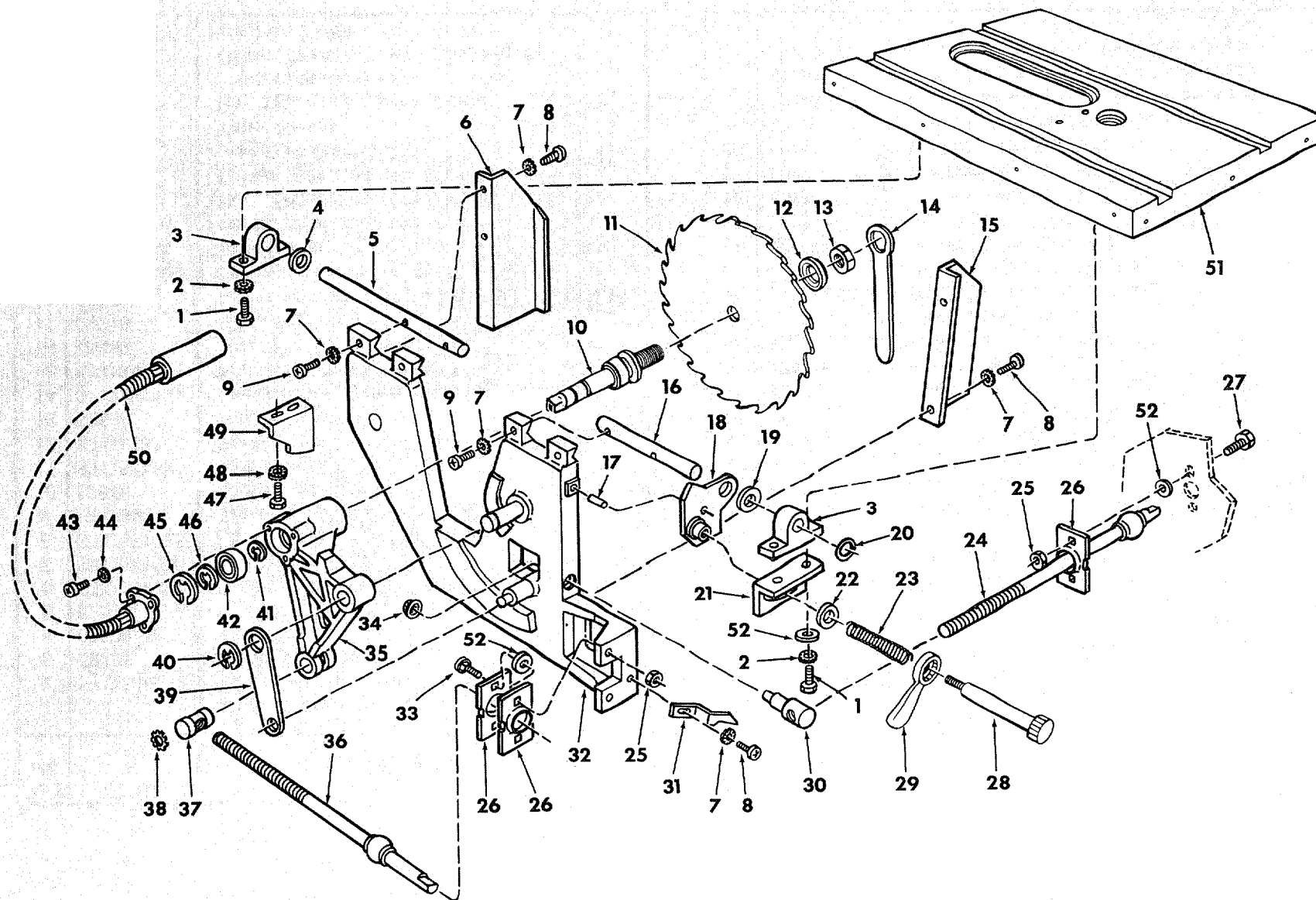

Figure 2

PARTS LIST FOR CRAFTSMAN 10 INCH TABLE SAW MODEL NO. 113.241680

FIGURE 2

Key No.	Part No.	Description
1	STD523110	*Screw, 5/16-18 x 7/8
2	STD551131	*Lockwasher, 5/16
3	62885	Support, Bearing
4	60537	Washer, .505 x 47/64 x 1/16
5	62883	Rod, Cradle
6	62870	Guard, Rear
7	STD551210	*Lockwasher, External No. 10
8	STD601103	*Screw, Pan Rec. Type "T" 10-32 x 3/8
9	STD511110	*Screw, Pan Cross 10-32 x 1
10	62897	Arbor Assembly
11	60175	†Blade, Saw 10"
12	62498	Collar, Blade
13	6362	Nut, Saw Arbor
14	3540	Wrench, Arbor
15	62869	Guard, Front
16	62882	Rod, Cradle
17	814579	Pin, Drive 1/4 x 5/8
18	62880	Plate, Stop
19	60535	Spacer, .505 x 3/4 x 1/4
20	62878	Nut, Push 1/2
21	62862	Bracket, Lock
22	STD551031	*Washer, .380 x 47/64 x 3/32
23	37828	Spring, Clamp Screw
24	62896	Shaft Assembly, Bevel
25	STD541411	*Nut, Lock 10-32
26	62881	Retainer, Bearing

Key No.	Part No.	Description
27	STD601103	*Screw, Pan Cross 10-32 x 3/8
28	37829	Screw, Clamp
29	18	Handle
30	62876	Nut, Bevel Pivot
31	62872	Indicator, Bevel
32	62893	Cradle Assembly (Includes Key No. 17)
33	60536	Bolt, Rd. Hd. Short Square Neck 10-32 x 5/8
34	60240	Nut, Push 3/8
35	62871	Housing, Arbor
36	62895	Shaft Assembly, Elevation
37	62877	Nut, Elevation
38	63054	Ring, Retaining 3/4
39	62874	Link
40	6527	Ring, Retaining 3/4
41	STD581062	*Ring, Retaining 5/8
42	3509	Bearing, Ball
43	STD601103	*Screw, Pan Cross Type "T" 10-32 x 3/8
44	STD551210	*Lockwasher, External No. 10
45	38879	Ring, Retaining
46	37158	Ring, Retaining 5/8
47	60078	Screw, 5/16-18 x 1/2
48	STD551131	*Lockwasher 5/16
49	62865	Bracket, Stop
50	62884	Shaft, Flexible
51	62887	Table
52	STD551012	*Washer 17/64 x 7/16 x 1/32

* Standard Hardware Item — May Be purchased locally.

† Stock Item - May be secured through the Hardware Department of most Sears Retail Stores or Catalog Order Houses.

PARTS LIST FOR CRAFTSMAN 10 INCH TABLE SAW MODEL NO. 113.241680

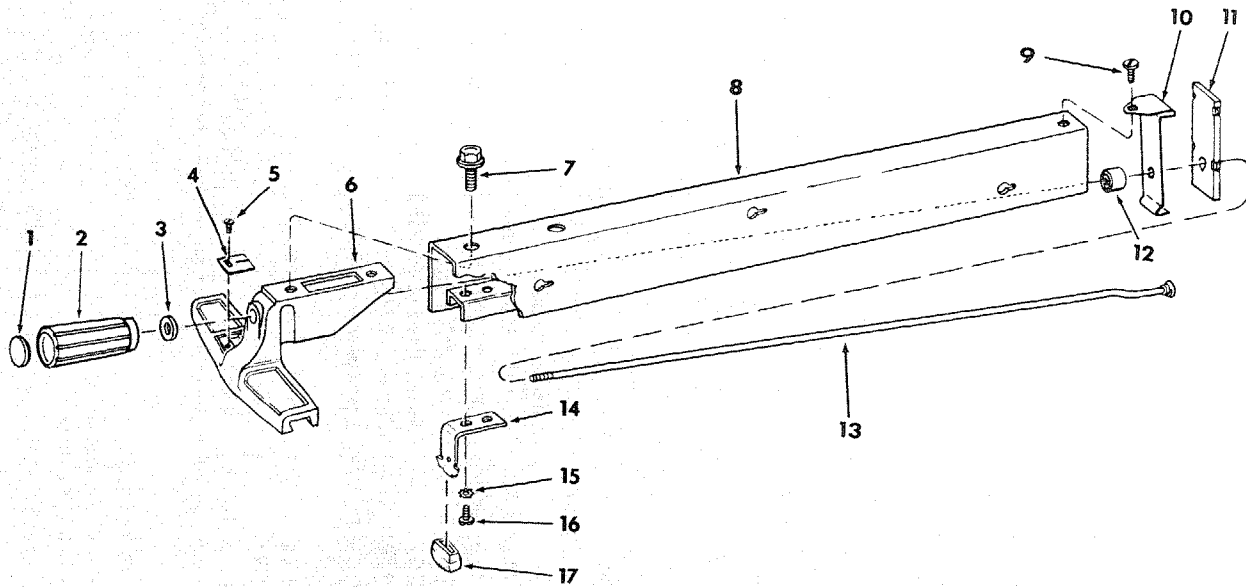

FIGURE 3 — 62773 FENCE ASSEMBLY

Key No.	Part No.	Description
-	62773	Fence Assembly, Rip
1	62693	Plug, Button
2	62692	Knob (Includes Key No. 1)
3	STD551031	*Washer, 21/64 I.D.
4	62775	Indicator, Fence
5	9404336	*Screw, Pan Hd. Type "T" 4-40 x 1/4
6	62774	Head, Fence Includes Key #4
7	423350	Screw, Sems 3/8-16 x 1/2
8	62582	Channel, Fence
9	STD600805	*Screw, Pan Hd. Type "T" 8-32 x 1/2
10	62528	Spring, Fence Lock
11	62529	Lock, Rear Fence
12	62531	Roller, Rear Fence
13	62583	Rod, Fence Lock
14	62533	Spring, Head Alignment (Includes Key No. 17)
15	STD551210	*Lockwasher, External No. 10
16	STD611005	*Screw, Type "A", Hex Ind. Sl. Wash. Hd. No. 10 x 1/2
17	62532	Pad, Alignment

* Standard Hardware Item — May Be Purchased Locally.

PARTS LIST FOR CRAFTSMAN 10 INCH TABLE SAW MODEL NO. 113.241680

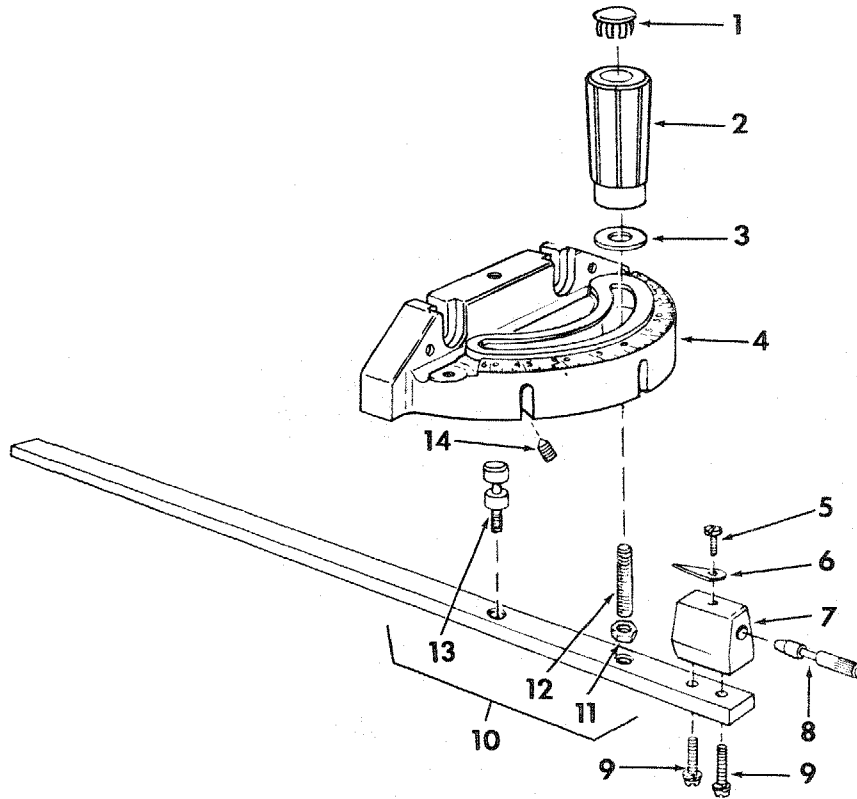

FIGURE 4 — MITER GAUGE ASSEMBLY

Key No.	Part No.	Description
	62704	+Gauge Assembly, Miter
1	62693	Plug, Button
2	62692	Knob, Miter Gauge (Included Key No. 1)
3	STD551031	*Washer, Plain 21/64 x 1 x 1/16
4	37893	Gauge, Miter
5	STD510803	*Screw, Pan Hd. 8-32 x 5/16
6	135	Indicator
7	37895	Block, Miter Gauge Indicator
8	37896	Pin, Miter Gauge Stop
9	9417295	*Screw, Pan Hd., w/Lockwasher 8-32 x 5/8
10	62230	Rod Assembly, Miter Gauge, Consisting of Items 11, 12, 13
11	STD541231	*Nut, Hex., 5/16-18
12	62225	Stud, Clamp
13	62383	Stud, Pivot
14	60288	Screw, Locking Set 1/4-20 x 3/8

LIST FOR CRAFTSMAN 10 INCH TABLE SAW MODEL NO. 113.241680

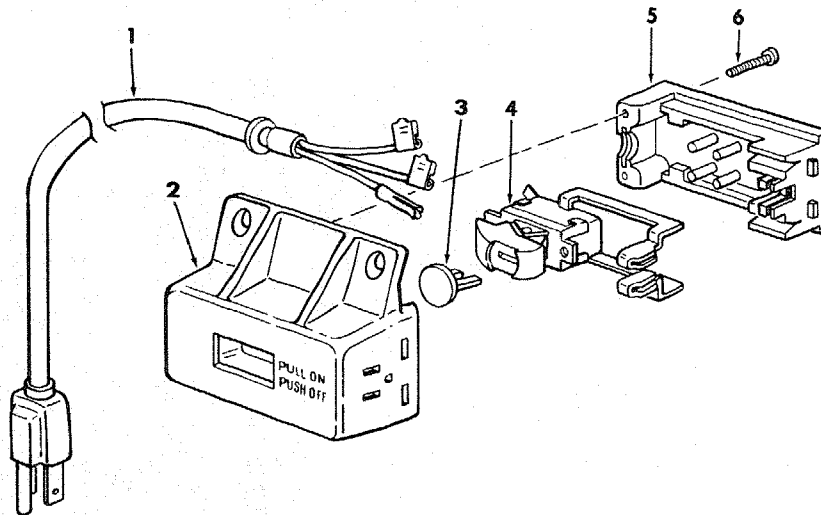

FIGURE 5 — ON/OFF POWER OUTLET 60381

Key No.	Part No.	Description
—	60381	• On/Off Power Outlet Complete
1	60375	Cord, Molded
2	60380	Housing, Switch
3	60256	Key, Switch
4	60374	Switch, Locking
5	60377	Cover, Switch
6	448007	Screw, Pan Hd. No. 6 x 3/4

- Does Not Include Key No. 3
Order Separately If Required.

PARTS LIST FOR CRAFTSMAN 10 INCH TABLE SAW MODEL NO. 113.241680

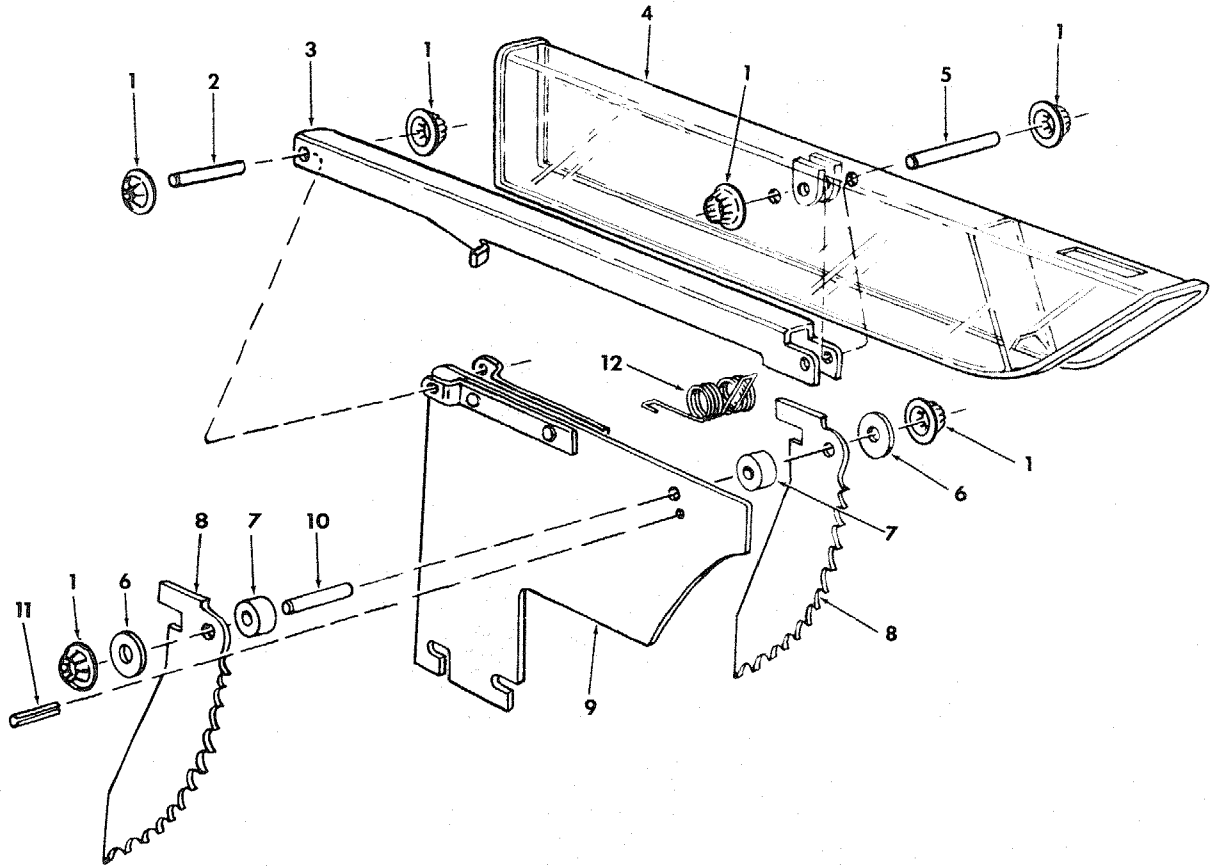
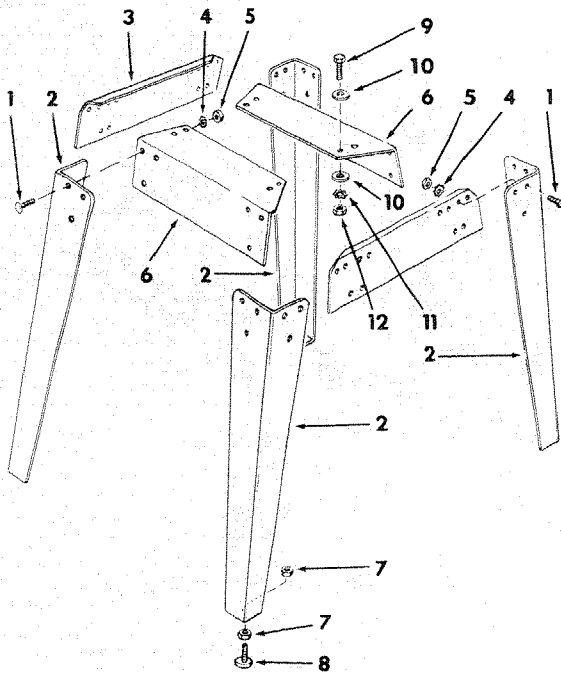

FIGURE 6 — GUARD ASSEMBLY

Key No.	Part No.	Description
	62894	Guard, Assembly, Saw
1	60297	Nut, Push
2	62391	Pin 1/4 x 1-1/2
3	62395	Support, Guard
4	62389	Guard, Saw
5	62390	Pin, 1/4 x 1-3/4
6	STD551025	*Washer, 17/64 x 5/8 x 1/16
7	62520	Spacer, Pawl
8	62879	Pawl
9	62861	Spreader, Blade
10	62410	Pin, 1/4 x 1-3/64
11	STD571810	*Pin, Roll, 3/16 x 15/16
12	62519	Spring, Pawl

PARTS LIST FOR CRAFTSMAN 10 INCH TABLE SAW MODEL NO. 113.241680

FIGURE 7 — LEGS



Key No.	Part No.	Description
1	60314	Screw, Serrated Truss Hd. 1/4-20 x 5/8
2	62552	Leg
3	62554	Stiffener, Side
4	STD551225	*Lockwasher, Ext. 1/4
5	STD541025	*Nut, Hex 1/4-20
6	62553	Stiffener, End
7	STD541250	*Nut, Hex 1/2-13
8	803835	Foot, Leveling
HARDWARE FOR ATTACHING LEGS TO SAW.		
9	STD523112	*Screw, Hex Hd. 5/16-18x1-1/4
10	STD551031	Washer, 11/32 x 11/16 x 1/16
11	STD551131	*Lockwasher, Ext. 5/16
12	STD541031	*Nut, Hex 5/16-18
	62752	Bag of Loose Parts For Legs (not illust.)

FIGURE 8 — TABLE EXTENSION 62589

Key No.	Part No.	Description
—	62589	†Extension Assembly, Complete
1	60323	Screw, Serrated Truss Hd., 1/4-20 x 1"
2	62590	Extension
3	62549	Bracket, Corner Support
4	STD541025	*Nut, Hex 1/4-20
5	STD551225	*Lockwasher, Ext. 1/4
6	62550	Bracket, Corner Stiffener
7	STD523112	*Screw, Hex Hd. 5/16-18x1-1/4
8	STD551131	*Lockwasher, Ext. 5/16
9	STD541031	*Nut, Hex 5/6-18
	62745	Bag of Loose Parts (not illust.)
10	STD551031	*Flat Washer, 11/32 I.D.
11	STD551025	*Flat Washer, 17/64 I.D.

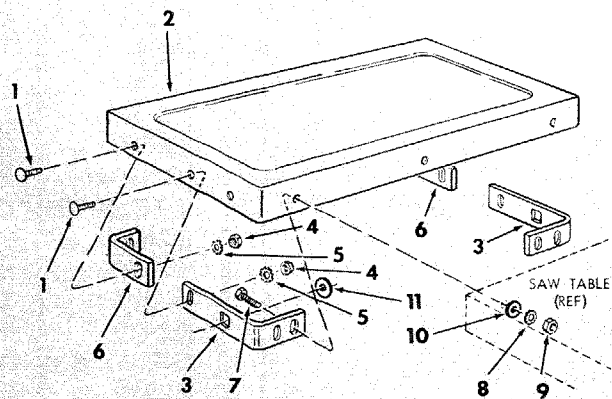

PARTS LIST FOR CRAFTSMAN 10 INCH TABLE SAW MODEL NO. 113.241680

NOTE:

**ANY ATTEMPT TO REPAIR THIS MOTOR
MAY CREATE A HAZARD UNLESS
REPAIR IS DONE BY QUALIFIED
SERVICE TECHNICIAN.**

**REPAIR SERVICE IS AVAILABLE
AT YOUR NEAREST SEARS STORE.**

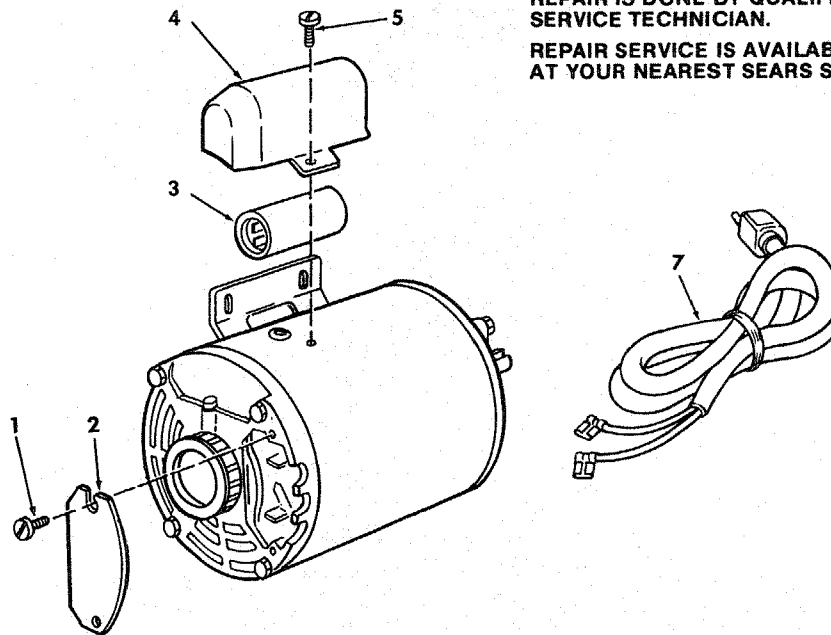

FIGURE 9 — 62855 MOTOR

Key No.	Part No.	Description
1	60306	Screw, 8-32 x 3/8, Thread Cutting, Slotted, Serrated Hd.
2	64088	Cover, Terminal
3	37588	Capacitor
4	37587	Cover, Capacitor
5	64142	Screw, 10-32 x 3/16, Thread Forming, Serrated Hd.
7	64258	Cord with Plug

SEARS

*owners
manual*

SERVICE

**MODEL NO.
113.241680**

SAW WITH LEGS
TWO TABLE EXTENSIONS
AND MOTOR

**HOW TO ORDER
REPAIR PARTS**

10 INCH FLEX DRIVE TABLE SAW

Now that you have purchased your 10-inch table saw should a need ever exist for repair parts or service, simply contact any Sears Service Center and most Sears, Roebuck and Co. stores. Be sure to provide all pertinent facts when you call or visit.

The model number of your 10-inch table saw will be found at the rear of the base.

WHEN ORDERING REPAIR PARTS, ALWAYS GIVE THE FOLLOWING INFORMATION:

PART NUMBER	PART DESCRIPTION
MODEL NUMBER 113.241680	NAME OF ITEM 10-INCH FLEX DRIVE TABLE SAW

All parts listed may be ordered from any Sears Service Center and most Sears stores. If the parts you need are not stocked locally, your order will be electronically transmitted to a Sears Repair Parts Distribution Center for handling.

Sold by SEARS, ROEBUCK AND CO., Chicago, IL. 60684 U.S.A.