

## Owner's Manual

# CRAFTSMAN<sup>®</sup>

1.5 HP (Max. Developed)  
1/2" and 1/4" Router Collet  
1/2" Removable Shaper Spindle

## BENCH TOP SHAPER/ROUTER

Model No.  
137.217100

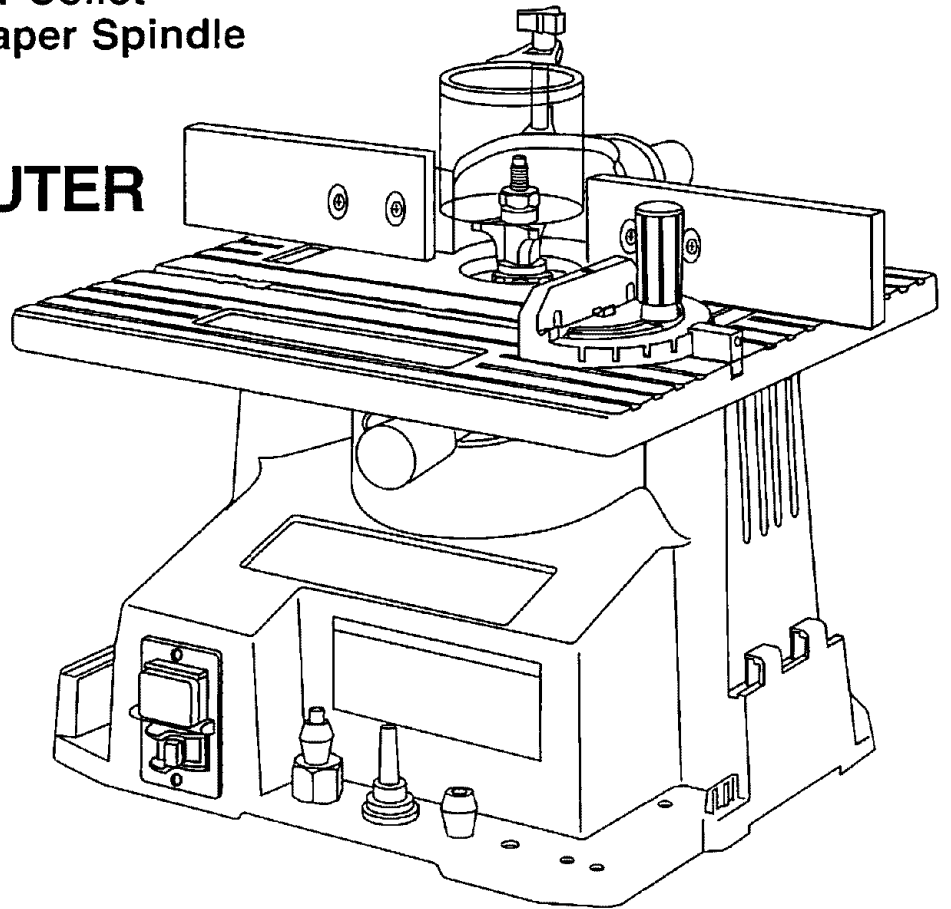

### CAUTION:

Before using this shaper/router, read this manual and follow all its Safety Rules and Operating Instructions.

- Safety Instructions
- Installation
- Operation
- Maintenance
- Parts List
- Español

**Customer Help Line**  
**1-800-843-1682**

Sears, Roebuck and Co., Hoffman Estates, IL 60179 USA  
Part No. 137217100001

## TABLE OF CONTENTS

SECTION	PAGE
Warranty .....	2
Product Specifications .....	2
Safety Instructions .....	3
Accessories and Attachments .....	6
Carton Contents .....	6
Know Your Shaper / Router .....	8
Assembly and Adjustments .....	9
Operation .....	14
Maintenance .....	18
Troubleshooting guide .....	19
Parts .....	20
Español .....	23

## PRODUCT SPECIFICATIONS

MOTOR .....	120 V, 60 HZ, 9 AMP AC	FENCE .....	Yes
DOUBLE INSULATED .....	Yes	MITER GAUGE .....	Yes
HORSEPOWER .....	1.5 HP (Max. Developed)	DUST CHUTE .....	Yes
SPINDLE		WEIGHT .....	35.5 lb
SPEED .....	10,000 R.P.M. (No Load)		
DIAMETER .....	1/2"		
HEIGHT ADJUSTMENT ..	7/8"		
ROTATION .....	Reversible		
CUTTER CAPACITY .....	2"		
ROUTER COLLET .....	1/2", 1/4"		
TABLE SIZE .....	18" X 15-7/16"		
TABLE INSERT .....	Reversible		

### **⚠ WARNING**

To avoid electrical hazards, fire hazards, or damage to the tool, use proper circuit protection. Use a separate electrical circuit for your tools.

Your shaper / router is wired at the factory for 120V operation. Connect to a 120V, 15 AMP branch circuit and use a 15 AMP time delay fuse or circuit breaker. To avoid shock or fire, replace power cord immediately if it is worn, cut or damaged in any way.

## WARNING

### **⚠ WARNING**

Some dust created by power sanding, sawing, grinding, drilling, and other construction activities contains chemicals known [to the State of California] to cause cancer, birth defects or other reproductive harm. Some examples of these chemicals are:

- Lead from lead-based paints.
- Crystalline silica from bricks, cement and other masonry products.
- Arsenic and chromium from chemically-treated lumber.

Your risk from these exposures varies, depending on how often you do this type of work. To reduce your exposure to these chemicals, work in a well ventilated area, and work with approved safety equipment, such as those dust masks that are specially designed to filter out microscopic particles.

# SAFETY

## GENERAL SAFETY INSTRUCTIONS BEFORE USING THE SHAPER / ROUTER

Safety is a combination of common sense, staying alert and knowing how to use your shaper / router.

### **⚠ WARNING**

To avoid mistakes that could cause serious injury, do not plug the shaper / router in until you have read and understood the following:

1. **READ** and become familiar with this entire instruction manual. **LEARN** the tool's applications, limitations, and possible hazards.
2. **KEEP GUARDS IN PLACE** and in working order.
3. **REMOVE ADJUSTING KEYS AND WRENCHES.** Form the habit of checking to see that keys and adjusting wrenches are removed from the tool before turning ON.
4. **KEEP WORK AREA CLEAN.** Cluttered areas and benches invite accidents.
5. **DON'T USE IN A DANGEROUS ENVIRONMENT.** Don't use power tools in damp or wet locations, or expose them to rain. Keep work area well lighted.
6. **KEEP CHILDREN AWAY.** All visitors should be kept at a safe distance from the work area.
7. **MAKE WORKSHOP KID PROOF** with padlocks, master switches, or by removing starter keys.
8. **DON'T FORCE THE TOOL.** It will do the job better and safer at the rate for which it was designed.
9. **USE THE RIGHT TOOL.** Don't force tool or the attachment to do a job for which it was not designed.
10. **USE PROPER EXTENSION CORD.** Make sure your extension cord is in good condition. When using an extension cord, be sure to use one heavy enough to carry the current your product will draw. An undersized cord will result in a drop in line voltage and loss of power which will cause the tool to overheat. The table on page 5 shows the correct size to use depending on cord length and nameplate ampere rating. If in doubt, use the next heavier gauge. The smaller the gauge number, the heavier the cord.
11. **WEAR PROPER APPAREL.** DO NOT wear loose clothing, gloves, neckties, rings, bracelets, or other jewelry which may get caught in moving parts. Non-slip footwear is recommended. Wear protective hair covering to contain long hair.
12.  **ALWAYS WEAR EYE PROTECTION.** Any shaper / router can throw foreign objects into the eyes which could cause permanent eye damage. **ALWAYS** wear Safety Goggles (not glasses) that comply with ANSI safety standard Z87.1. Everyday eyeglasses have only impact-resistant lenses. They **ARE NOT** safety glasses. Safety Goggles are available at Sears. **NOTE:** Glasses or goggles not in compliance with ANSI Z87.1 could seriously hurt you when they break.
13. **WEAR A FACE MASK OR DUST MASK.** Shaping operation produces dust.
14. **SECURE WORK.** Use clamps or a vise to hold work when practical. It's safer than using your hand and it frees both hands to operate tool.
15. **DISCONNECT TOOLS** before servicing, and when changing accessories, such as blades, bits, cutters, and the like.
16. **REDUCE THE RISK OF UNINTENTIONAL STARTING.** Make sure the switch is in OFF position before plugging in.
17. **USE RECOMMENDED ACCESSORIES.** Consult the owner's manual for the recommended accessories. The use of improper accessories may cause risk of injury to persons.
18. **NEVER STAND ON TOOL.** Serious injury could occur if the tool is tipped or if the cutting tool is unintentionally contacted.
19. **CHECK FOR DAMAGED PARTS.** Before further use of the tool, a guard or other part that is damaged should be carefully checked to determine that it will operate properly and perform its intended function. Check for alignment of moving parts, binding of moving parts, breakage of parts, mounting, and any other conditions that may affect its operation. A guard or other part that is damaged should be properly repaired or replaced.
20. **NEVER LEAVE TOOL RUNNING UNATTENDED. TURN THE POWER OFF.** Don't leave the tool until it comes to a complete stop.
21. **DON'T OVERREACH.** Keep proper footing and balance at all times.
22. **MAINTAIN TOOLS WITH CARE.** Keep tools sharp and clean for best and safest performance. Follow instructions for lubricating and changing accessories.
23. **DIRECTION OF FEED.** Feed work into a blade or cutter against the direction of the rotation of the blade or cutter only.

## SAVE THESE INSTRUCTIONS

24. **DO NOT** operate the tool if you are under the influence of any drugs, alcohol or medication that could affect your ability to use the tool properly.
25. Dust generated from certain materials can be hazardous to your health. Always operate the shaper / router in a well-ventilated area and provide for proper dust removal. Use dust collection systems whenever possible.

## SPECIFIC SAFETY INSTRUCTIONS FOR THE SHAPER/ROUTER

### **▲ WARNING**

Do not operate your shaper / router until it is completely assembled and installed according to the instructions.

1. **IF YOU ARE NOT** thoroughly familiar with the operation of shaper / routers, obtain advice from your supervisor, instructor, or other qualified person.
2. **MAKE SURE** wiring codes and recommended electrical connections are followed and that the machine is properly grounded.
3. **NEVER** turn the shaper / router ON until all tools, scraps of wood, and other debris are removed from the table.
4. **DO NOT** shape or rout materials less than 12" in length or 4" in width without special supporting fixtures. Use a holding jig or fixture to guide it past the cutter.
5. **ALWAYS** use a miter gauge when edge-shaping a workpiece less than 6" wide. Keep your hands at least 6" away from the cutting tool.
6. **AVOID** awkward hand positions. A sudden slip could allow your hand to contact the cutter.
7. **USE A PUSH STICK** or a scrap piece of work material to push the workpiece, to keep your hands safely away from the cutter.
8. **NEVER** run the workpiece between the cutter and the fence backstop.
10. **USE AUXILIARY GUIDES** clamped to the fence or table, if necessary, to keep your hands safely away from the cutter.
11. **DO NOT** feed material that is warped, contains knots, or is embedded with foreign objects, such as nails or staples.
12. **NEVER** start the shaper / router with the workpiece in contact with the cutter.
13. **ALWAYS** use the cutter safety guard provided with the machine.
14. **NEVER** perform layout, assembly, or set-up work on the table while the shaper is operating.
15. **KEEP** the cutting tools sharp and free from rust and pitch.
16. **ALWAYS ADJUST** the fence as close as possible to the cutter, keeping the cutter between the fence boards.
17. **ALWAYS** lock the fence hardware securely after making fence adjustments.
18. **MAKE CERTAIN** the cutting tools are properly installed and secured before starting the machine.
19. **MAKE SURE** the shaper / router is mounted to a secure surface. Check carefully for any tipping or "walking", and secure the workbench or supporting surface before using the tool.
20. **MAKE SURE THE KEYED WASHER** is installed directly under the SPINDLE JAM NUT and the nut is tight. Serious injury may result if the nut loosens.
21. **ALWAYS LOCK** the cutter depth lock handle after adjusting it.
22. **ALWAYS** use a collar or bearing guide if cutting with the fence assembly removed.
23. **DO NOT** perform any operation freehand. **ALWAYS:**
  - **USE THE FENCE** for straight shaping.
  - **USE THE MITER GAUGE** for end shaping.
  - **USE THE STARTING PIN AND COLLARS** for curve shaping.
24. **ALWAYS** feed the workpiece **AGAINST** the cutter rotation.
25. **WHEN SHAPING** with collars and the starting pin:
  - **THE COLLAR MUST** have sufficient bearing surface for contacting the workpiece.
  - **THE WORKPIECE MUST** be fairly wide in proportion to the cut being made. **NEVER** shape short workpieces of narrow material.
  - **THE CUTTER SHOULD** be positioned below the collar whenever possible.
26. **MAKE** all adjustments with the power OFF.
27. **WEAR EAR PROTECTION** when operating this tool.
28. **AVOID** deep cuts. Excessive depth of cut can cause kick-back.

## ELECTRICAL REQUIREMENTS

### POWER SUPPLY AND MOTOR SPECIFICATIONS

The AC motor used in this saw is a universal, nonreversible type. See "MOTOR" in the **PRODUCT SPECIFICATIONS** section on page 2.

### **▲ WARNING**

To avoid electrical hazards, fire hazards, or damage to the tool, use proper circuit protection. Your saw is wired at the factory for 120V operation. Connect to a 120V, 15 Amp circuit and use a 15 Amp time delay fuse or circuit breaker. To avoid shock or fire, if power cord is worn or cut, or damaged in any way, have it replaced immediately.

**SAVE THESE INSTRUCTIONS**

## DOUBLE INSULATED

The shaper / router is double insulated to provide a double thickness of insulation between you and the tool's electrical system. All exposed metal parts are isolated from the internal metal motor components with protecting insulation.

**Replacement parts** - When servicing use only identical replacement parts.

**Polarized plugs** - This shaper / router has a plug that looks like the one shown below:

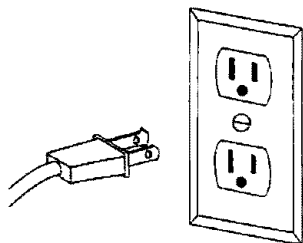

To reduce the risk of electrical shock, this shaper / router has a polarized plug (one blade is wider than the other). This plug will fit in a polarized receptacle only one way. If the plug does not fit fully in the receptacle, reverse the plug. If it still does not fit, contact a qualified electrician to install the proper receptacle. Do not change the plug in any way.

### **⚠ WARNING**

Double insulation does not take the place of normal safety precautions when operating this tool.

### **⚠ WARNING**

To avoid electrocution:

1. Use only identical replacement parts when servicing a tool with double insulation. Servicing should be performed by a qualified technician.
2. Do not use power tools in wet or damp areas or expose them to rain. This tool is intended for indoor use only.

## MOTOR SAFETY PROTECTION

**IMPORTANT:** To avoid motor damage, this motor should be blown out or vacuumed frequently to keep sawdust from interfering with normal motor ventilation.

1. Connect this tool to a 120V, 15 Amp branch circuit with a 15 Amp time delay fuse or circuit breaker. Using the wrong size fuse can damage the motor.
2. If the motor won't start, turn the switch OFF immediately. **UNPLUG THE TOOL.** Check the spindle shaft to make sure it turns freely. If the spindle is free, try to start the motor again. If the motor still does not start, contact the Sears Service Center.
3. If the motor suddenly stalls while shaping wood, turn the switch OFF, unplug the tool, and free the cutter from the wood. The shaper may now be restarted and the cut finished.
4. Fuses may "blow" or circuit breakers may trip frequently if:

- a. Motor is overloaded. Overloading can occur if you feed too rapidly or make too many start / stops in a short time.
  - b. Line voltage is more than 10% above or below the nameplate voltage. For heavy loads, however, the voltage at motor terminals must equal the voltage specified on the nameplate.
  - c. Improper or dull cutters are used.
5. Most motor troubles may be traced to loose or incorrect connections, overload, low voltage (such as small size wire in the supply circuit) or to overly long supply circuit wire. Always check the connections, the load and the supply circuit if the motor doesn't work well. Check wire sizes and length with the Extension Cord Chart below.

## GUIDELINES FOR EXTENSION CORDS

**USE PROPER EXTENSION CORD.** Make sure your extension cord is in good condition. When using an extension cord, be sure to use one heavy enough to carry the current your product will draw. An undersized cord will result in a drop in line voltage, and loss of power which will cause the tool to overheat. The table below shows the correct size to use depending on cord length and nameplate ampere rating. If in doubt, use the next heavier gauge. The smaller the gauge number, the heavier the cord.

**Be sure your extension cord is properly wired and in good condition.** Always replace a damaged extension cord or have it repaired by a qualified person before using it. Protect your extension cords from sharp objects, excessive heat and damp or wet areas.

Use a separate electrical circuit for your tools. This circuit must not be less than #12 wire and should be protected with a 15 Amp time lag fuse. Before connecting the motor to the power line, make sure the switch is in the OFF position and the electric current is rated the same as the current stamped on the motor nameplate. Running at a lower voltage will damage the motor.

MINIMUM GAUGE FOR EXTENSION CORDS (AWG)				
(when using 120 volts only)				
Ampere Rating		Total length of cord in feet		
more than	not more than	25'	50'	100' 150'
0	6	18	16	16 14
6	10	18	16	14 12
10	12	16	16	14 12
12	16	14	12	Not recommended

### **⚠ WARNING**

To avoid injury, make certain the receptacle is properly grounded. If you are not sure have a certified electrician check the receptacle.

### **⚠ WARNING**

This shaper / router is for indoor use only. Do not expose to rain or use in damp locations.

# SAVE THESE INSTRUCTIONS

## ACCESSORIES AND ATTACHMENTS

### PROHIBITED ACCESSORIES

#### **▲ WARNING**

Use only accessories recommended for this shaper / router. Follow instructions that accompany accessories. Use of improper accessories may cause hazards.

#### **▲ WARNING**

Do not attempt to modify this tool or create accessories not recommended for use with this tool. Any such alteration or modification is misuse and could result in a hazardous condition leading to possible serious injury.

### RECOMMENDED ACCESSORIES

Visit your Sears Hardware Department or see the Craftsman Power and Hand Tools Catalog to purchase recommended accessories for this power tool.

#### **▲ WARNING**

To avoid the risk of personal injury, do not modify this power tool or use accessories not recommended by Sears

## CARTON CONTENTS

### UNPACKING AND CHECKING CONTENTS

#### **▲ WARNING**

To avoid injury from unexpected starting or electrical shock, do not plug the power cord into a power source receptacle during unpacking and assembly. This cord must remain unplugged whenever you are working on the shaper / router.

1. Carefully unpack the shaper / router and all its parts, and compare against the illustration on page 7.
2. Place the tool on a secure surface and inspect carefully.

#### **▲ WARNING**

If any part is missing or damaged, do not plug the shaper / router in until the missing or damaged part is replaced, and assembly is complete. To avoid electrical shock, use only identical replacement parts when servicing double insulated tools.

### TABLE OF LOOSE PARTS

<u>ITEM</u>	<u>DESCRIPTION</u>	<u>QUANTITY</u>
A.	Shaper / Router	1
B.	Miter gauge	1
C.	Fence backstop	1
D.	Wooden boards	2
E.	Sliding fence bracket	1
F.	Guard assembly	1
G.	Lock knobs (2 short - 2 long)	4
H.	Washers (large opening, flat)	5
I.	Washers (small, flat)	2
J.	Hex. nuts	4
K.	Screws (flat head phillips)	4
L.	Dust chute	1
M.	Table insert	1
N.	Shaper spindle	1
O.	Collars	5
P.	Keyed washer	1
Q.	Hex nut	1
R.	Router nut (large & small hole)	1
S.	Starting pin	1
T.	1/2" Collet	1
U.	1/4" Collet	1
V.	Shaper nut (large & large hole)	1
W.	Wrenches (open end)	2

# UNPACKING YOUR SHAPER / ROUTER

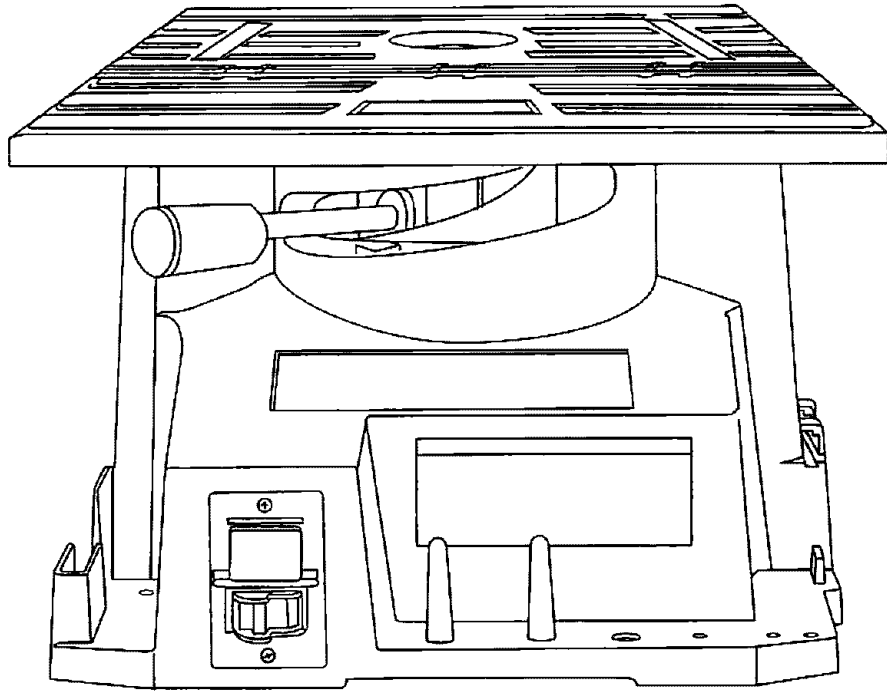

A

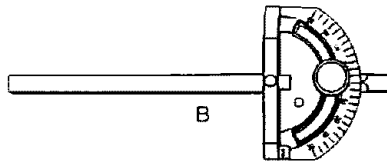

B

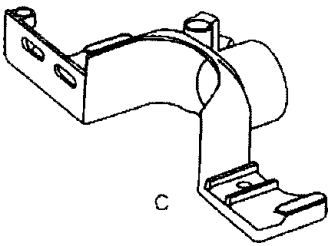

C

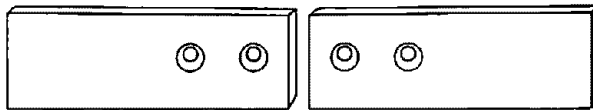

D

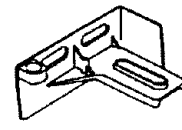

E

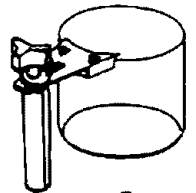

F

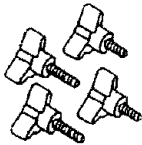

G



H



I



J



K

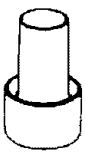

L



M



N



O



P



Q



R



S



T



U



V



W

# KNOW YOUR SHAPER / ROUTER

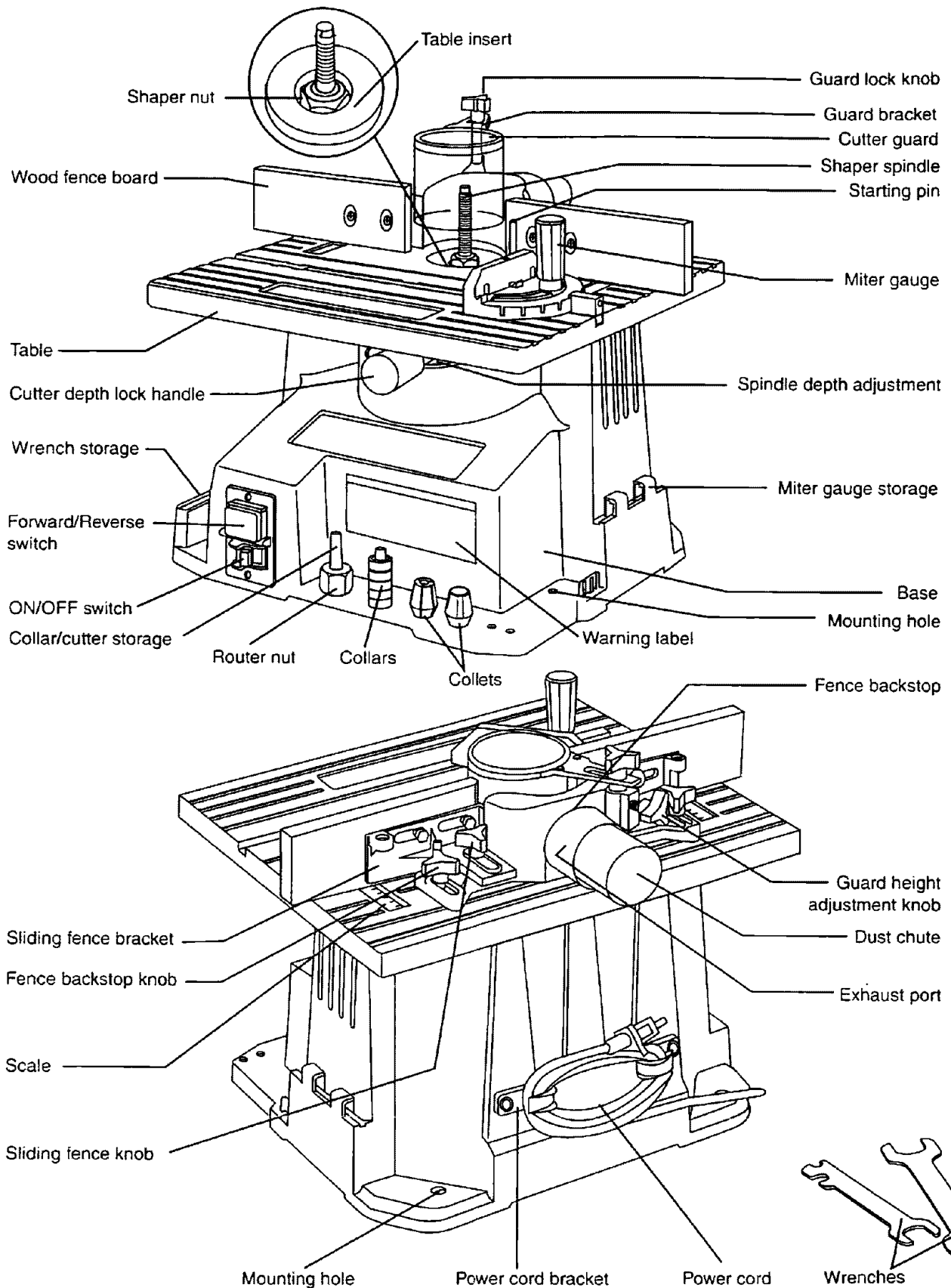



# ASSEMBLY AND ADJUSTMENTS

## ASSEMBLY INSTRUCTIONS

### TOOLS NEEDED

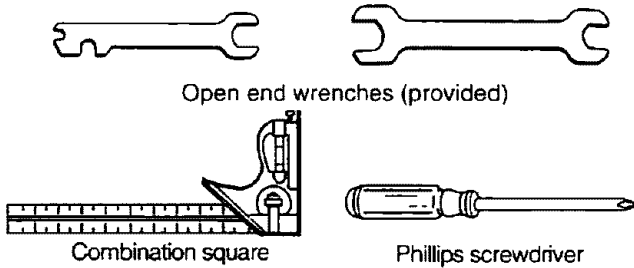

### ⚠ WARNING

For your safety, never connect the plug to the power source receptacle until all assembly and adjustment steps are completed, and you have read and understood the safety and operating instructions.

### INSTALLING THE FENCE ASSEMBLY (FIG. A, B, C)

#### The Backstop (FIG. A)

1. Place the fence backstop (1) on the table, aligned with the two holes (2) at the rear of the table.
2. Insert a long knob (3) through a washer (4), and thread through a slot (5) of the backstop into the table hole.
3. Repeat for the other backstop slot, and tighten the two knobs.

Fig. A

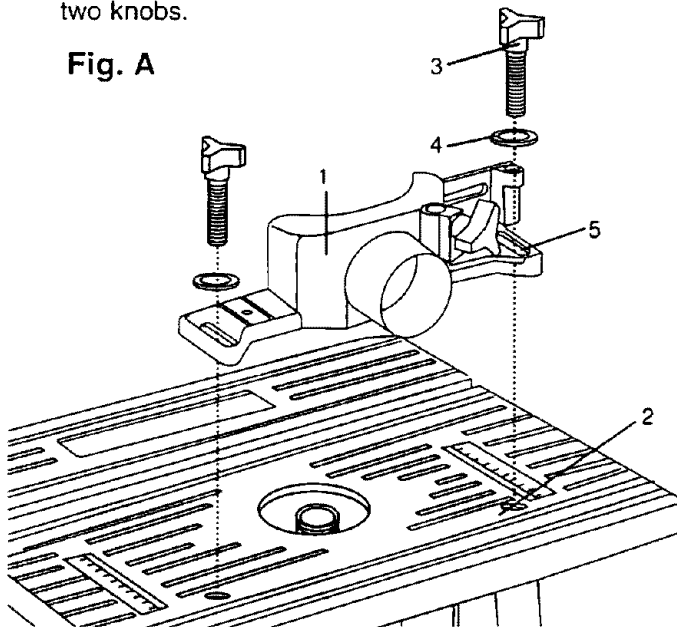

#### The Sliding Bracket (FIG. B)

1. Place the sliding bracket (6) on the grooved track at the side of the backstop.
2. Thread a short knob (7), with a washer (4), through the bracket slot (8) into the threaded hole of the backstop. Tighten the knob.

Fig. B

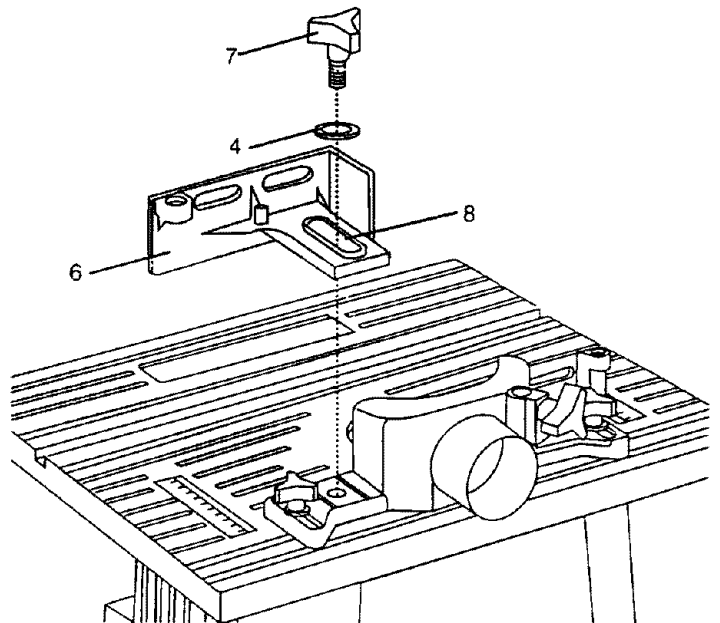

#### The Wood Fence (FIG. C)

1. Install the two wood fence boards (9) to the fence brackets. Place them with the beveled edge toward the center, facing the cutter shaft, as shown.
2. Insert four phillips flat head screws (10) through the front of the boards.
3. Place the flat washers (11) and hex nuts (12) on the screws from the fence backstop side.
4. Loosen the fence lock knobs, adjust the fence brackets to their most forward position. Tighten the lock knobs.
5. Using a straightedge or combination square, align the two wooden boards so they are even with each other. Tighten the screws and nuts.

Fig. C

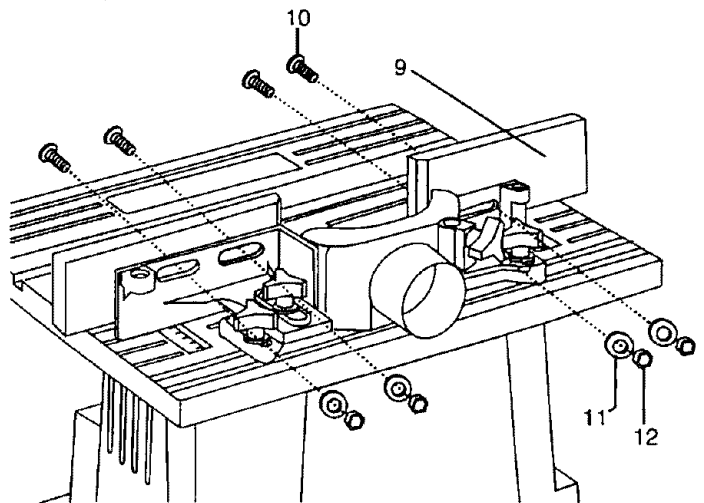

### INSTALLING THE DUST CHUTE (FIG. E)

Place the dust chute (1) firmly into the fence backstop port (2). A wet / dry shop vacuum hose can be attached to the chute to help keep the work area free of wood chips.

**CAUTION:** Never leave a wet / dry vacuum hose connected unless the vacuum is turned on during operation, or the machine will clog with chips.

Fig. E

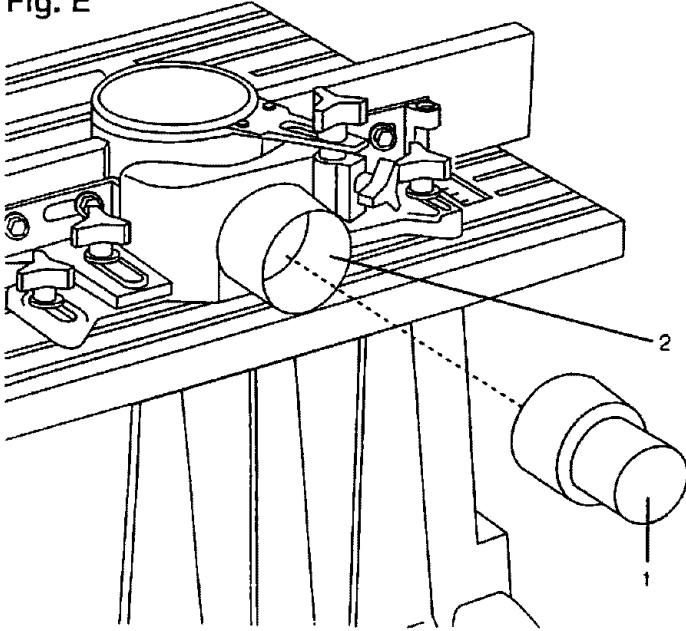

### TABLE INSERT (FIG. F)

The table insert must be in position when shaping a workpiece, to provide support and to keep dust and chips out of the spindle area.

1. When the cutter or router bit is positioned above the table surface, install the table insert with the smaller hole (1) up, to provide a surface flush with the table.
2. When the cutter or router bit is positioned partially below the table surface, the insert must be installed with the larger opening facing (2) up, to provide a recessed surface.

**CAUTION:** Make sure the cutter will not hit the table insert before turning the tool ON.

Fig. F

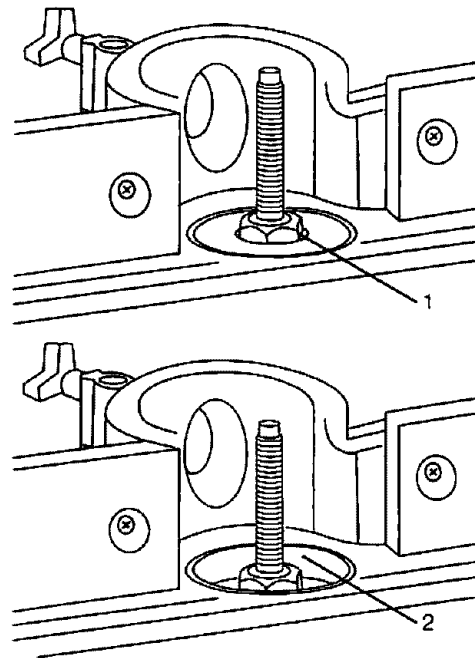

### STARTING PIN (FIG. G)

The starting pin (1) is used to support the workpiece when using the shaper / router without the fence and sliding bracket. Thread the starting pin into the table hole (2) located approximately 4" from the spindle shaft (3).

Fig. G

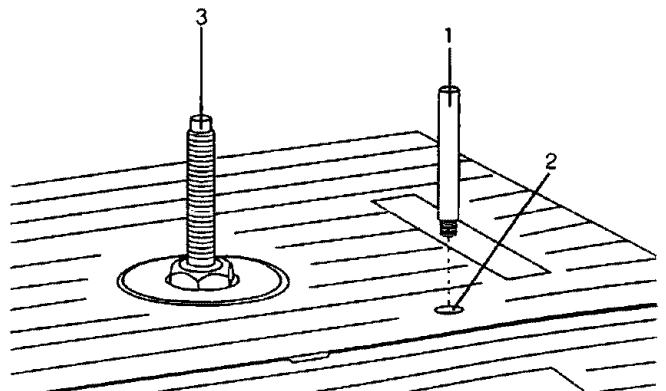

## INSTALLING SHAPER CUTTERS (FIG. H, I, J, K)

### **⚠ WARNING**

To avoid injury from an accidental start, make sure the switch is in the OFF position and the plug is not connected to the power source receptacle before changing any cutters.

To use 1/2" bore shaper cutters, install the 1/2" shaper spindle:

1. BE SURE THE MACHINE IS NOT CONNECTED TO THE POWER SOURCE.
2. Turn the cutter depth lock handle (1) 1/4 turn counterclockwise to unlock.
3. Raise the tool spindle (2) to its highest point by moving the cutter depth lock handle to the right.
4. Lock the height of the tool spindle by turning the lock handle clockwise until tight. (FIG. H)

Fig. H

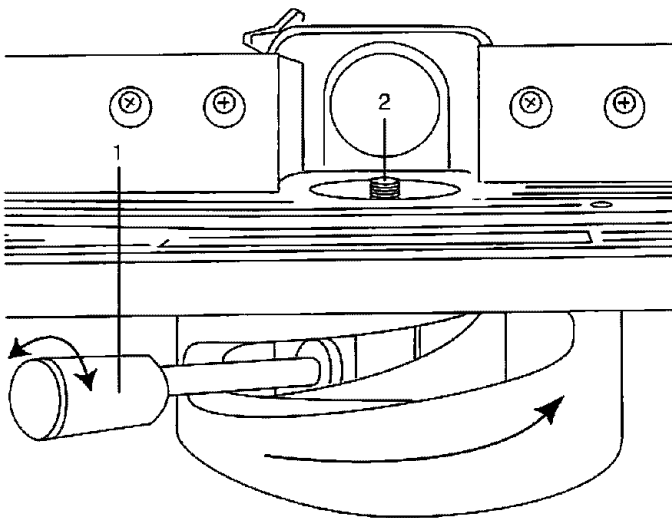

5. Remove the table insert.
6. Locate the shaper spindle (3) and the shaper spindle nut (4). The shaper spindle nut is the large nut with a large opening at both ends, and two different types of threads.
7. Thread the shaper spindle into the small diameter threads in the shaper spindle nut.
8. The shoulder (5) of the threaded portion of the shaper spindle should protrude at least 1/16" above the face of the nut (4).
9. Maintain this 1/16" spindle position as you thread the tapered end of the shaper spindle and nut assembly onto the tool spindle (2) and hand tighten. (FIG. I)

Fig. I

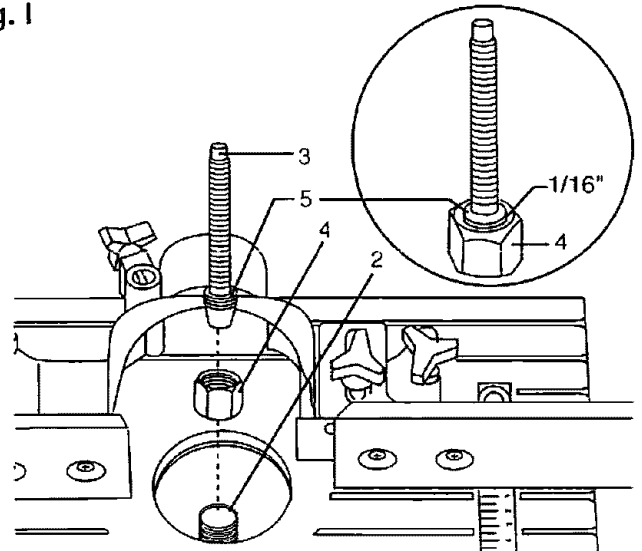

10. Tighten and lock the nut (4) and shaper spindle (3) onto the tool spindle (2) by inserting one open-end wrench into the slot (6) under the table to hold the flats of the tool spindle, and placing the other open-end wrench on the shaper spindle nut (4) above the table. Tighten clockwise. (FIG. J)

Fig. J

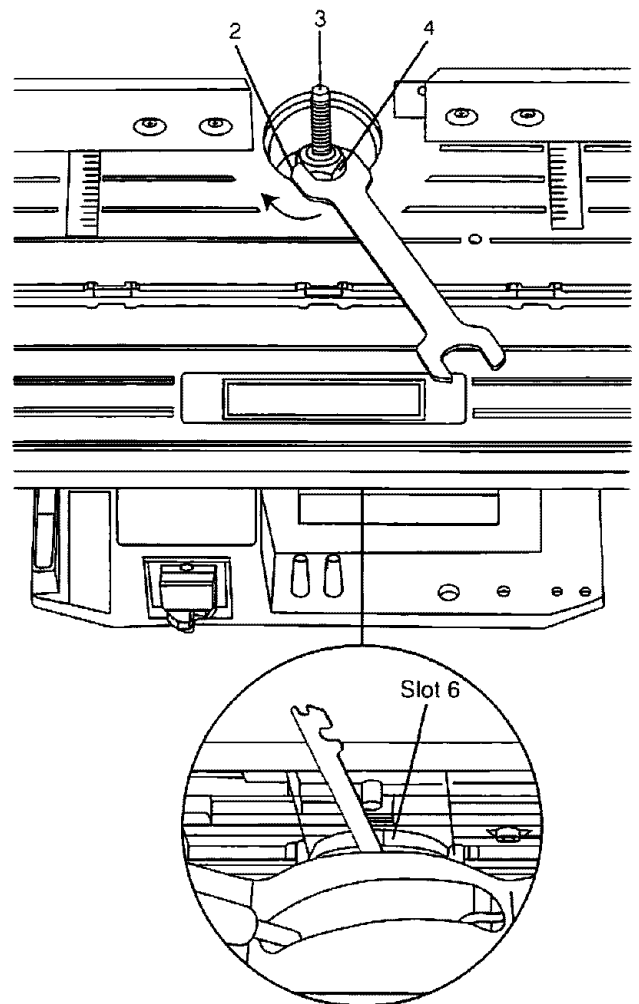

11. Replace the table insert.
12. Place a 1/2" bore cutter (7) (not supplied) on the shaper spindle (3). (See "OPERATION" section for proper arrangement of cutters and collars.) If the cutter has a hole larger than 1/2" use bushings to reduce the size to 1/2".

**NOTE:** If the cutting edge of the shaper does not rotate in the in-feed direction and toward the backstop, reverse the cutter or the spindle rotation. (See "OPERATION" section).

13. Place the keyed washer (8) on the shaper spindle, fitting the washer tab into the spindle groove (9).
14. Place the large hex nut (10) on the shaper spindle and tighten clockwise. Use the large wrench to hold the shaper spindle nut (4), and the smaller wrench to tighten and lock the hex nut. (Fig. K)

**Fig. K**

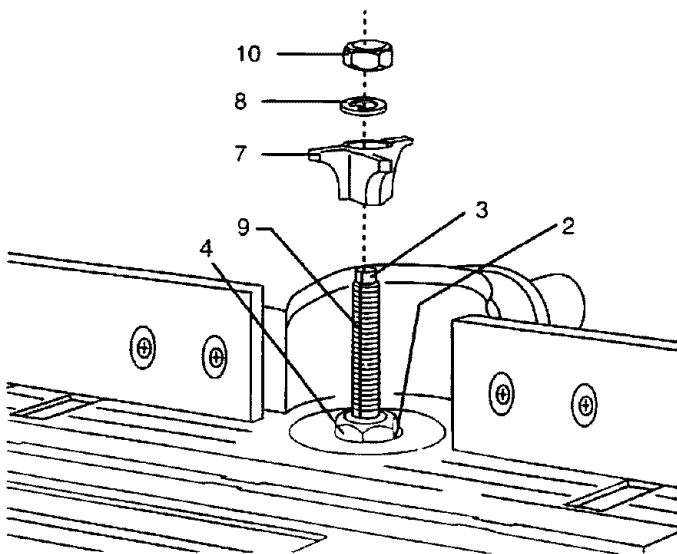

**▲ WARNING**

When installing shaper cutters, the keyed washer **MUST** be directly under the hex jam nut. Otherwise the nut may loosen and cause serious injury.

15. To use router bits for shaping, remove the shaper cutter and the shaper spindle assembly by reversing the procedure above. Be sure to unplug the tool from the power source, before performing any assembly or disassembly procedures.

**INSTALLING ROUTER BITS (FIG. H, L)**

**▲ WARNING**

To avoid injury from an accidental start, make sure the switch is in the OFF position and the plug is not connected to the power source receptacle before changing any cutters.

Install 1/2" or 1/4" router bits:

1. **BE SURE THE MACHINE IS NOT CONNECTED TO THE POWER SOURCE.**

2. Remove the table insert.
3. Turn the cutter depth lock handle (1) 1/4 turn counterclockwise to unlock.
4. Raise the tool spindle (2) to its highest point by moving the cutter depth lock handle to the right.
5. Lock the height of the tool spindle by turning the lock handle clockwise until tight. (FIG. H)
6. Locate a size collet (3) to match the size of your router bit shank (4). Locate the router nut (5) that has a thread in one end and a smooth type taper in the other end.
7. Place the collet into the tapered bore of the tool spindle (2). Place the tapered end of the router nut over the collet and hand turn onto the spindle.

**CAUTION:** DO NOT TIGHTEN this or any collet without a bit in place or the collet will crack.

8. Place the shank (4) of the router bit all the way into the collet. Pull it back out approximately 1/16", and tighten the router nut.
9. Insert one open-end wrench into the slot (6) under the table to hold the flats of the tool spindle, and place the other open-end wrench on the router nut (5) above the table. Tighten router nut clockwise. (FIG. L)

**CAUTION:** Make sure that the shaper/router direction switch is set to cut the workpiece from right to left. Router bits cannot be inverted to cut from the opposite direction.

10. To use shaper cutters for shaping, remove the router assembly by reversing the procedure above. Be sure to unplug the tool from the power source, before performing any assembly or disassembly procedures.

**Fig. L**

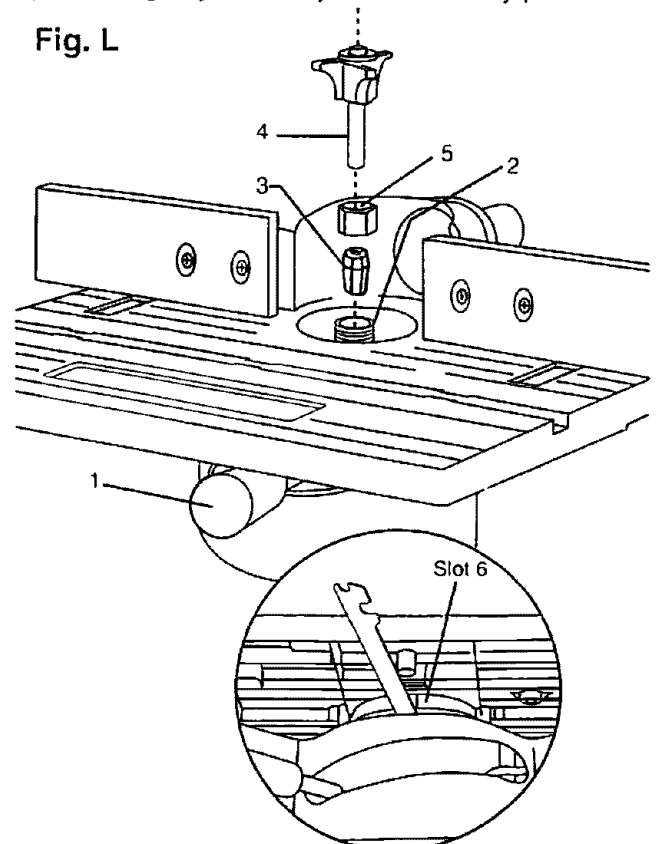

## MOUNTING THE SHAPER / ROUTER (FIG. M)

1. To mount your shaper/router in a permanent location such as a sturdy workbench, bolt the shaper base to a solid workbench top. The shaper base (1) has 4 mounting holes.
2. Place the shaper/router on the work surface (5), mark the holes on the work surface and drill 3/8" holes. Use bolts, washers, nuts to secure.
3. If the workbench moves or shakes during operation, it must be fastened to the floor.
4. Your shaper/router is designed to be used on horizontal surfaces only. Motor damage may result when mounted on a non-horizontal surface.

Fig. M

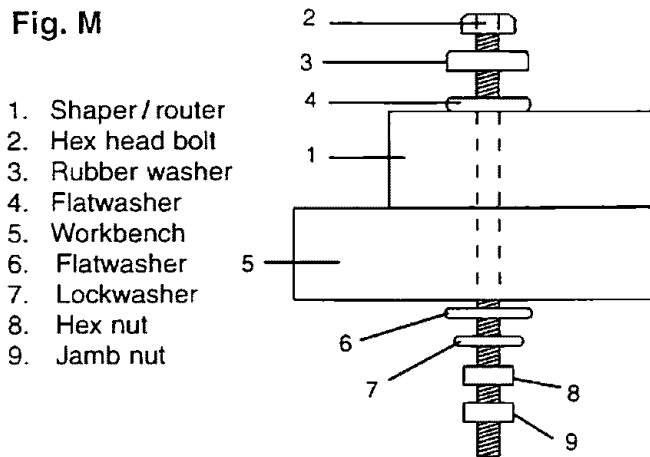
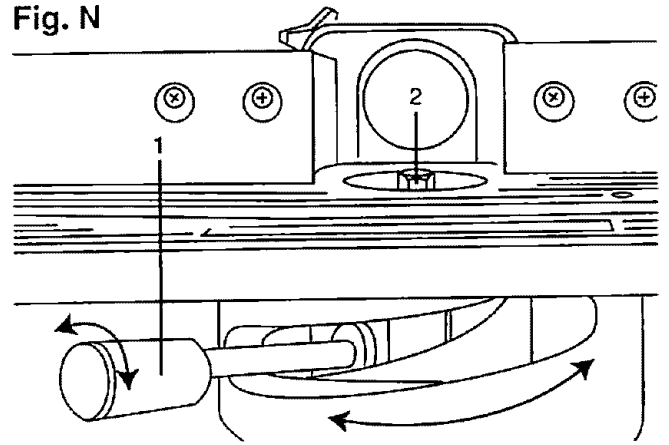

Fig. N



## Adjusting the fence (FIG. O)

1. To move the entire fence position, loosen the two knobs (1) behind the backstop (2). Slide the fence backstop forward or backwards. The fence mounting slots allow up to 1-1/4" adjustment.
2. Position the fence so the bit or cutter is located directly between the fence boards (3). Tighten the knobs securely.
3. To move the fence boards, loosen the mounting screws (4) and nuts. The board slots allow up to 1" sideways adjustment.
4. Slide the boards toward the center until they are as close as possible to the guard (5) without touching it. Tighten the screws and nuts securely. Use a straightedge and the scales on the table to check their alignment.
5. The sliding fence bracket (6) allows an individual side adjustment of up to 1-3/4". To move the sliding bracket, loosen the bracket knob (7).
6. Slide the bracket backwards or forwards in its grooved track to the desired position; tighten the knob securely.
7. Proper fence settings for various cutting applications are shown in the OPERATION section.

Fig. O

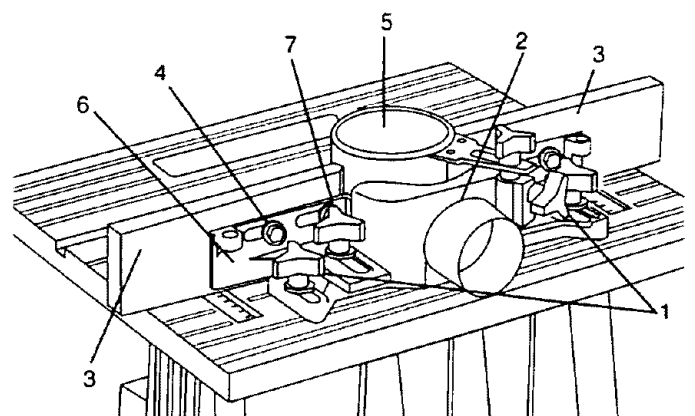

## Adjusting height with spacer collars

The cutting height of shapers or router bits can be adjusted further by placing collars below or between the cutters. Certain requirements MUST be followed when using this method, explained in the OPERATION section.

## ADJUSTMENT INSTRUCTIONS

### ⚠ WARNING

To avoid injury from an accidental start, always make sure the switch is OFF and the plug is removed from the power source before making any adjustments.

### ADJUSTING THE HEIGHT AND DEPTH OF CUT (FIG. N, O)

The cutting depth can be adjusted three ways: adjusting the spindle height, moving the fence, and by using of spacing collars above and below the shaper cutter or router bit. The cutting depth and alignment of both fence sides can be individually and accurately controlled with the help of the scales on the table.

#### Adjusting the spindle (FIG. N)

An adjustment is provided for convenience of installing and removing bits and cutters, and to adjust the cutter height for various shaping applications.

1. Unlock the cutter depth lock handle (1) on the front of the shaper/router by turning the handle 1/4 turn counterclockwise.
2. Move the handle to the right to raise the spindle (2), and to the left to lower the spindle.
3. Lock the spindle in the desired position by turning the handle clockwise until tight.

### ADJUSTING THE GUARD (FIG. P)

1. The clear cutter guard (1) should always be used with the fence, and can be rotated out of the way when making adjustments or changing cutters.
2. Adjust the fence to the position appropriate to the cutting job.
3. Loosen the top guard knob (2) and slide the guard to center it over the cutter. Tighten the knob.
4. Loosen the back guard knob (3) and slide the guard up or down to a position as low as possible between the wooden boards, without touching the cutter, and approximately 1/4" above the workpiece. Tighten the knob.

Fig. P

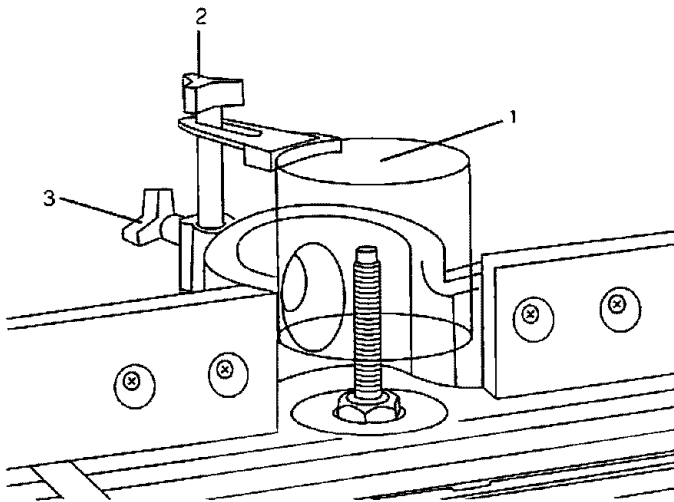

3. To turn the shaper / router OFF push the switch to the left position.
4. Remove the yellow switch key, when the shaper / router has come to a complete stop, by gently pulling it outward.

### ⚠ WARNING

Remove the switch key whenever the shaper / router is not in use. Place it in a safe place and out of reach of children.

Fig. Q

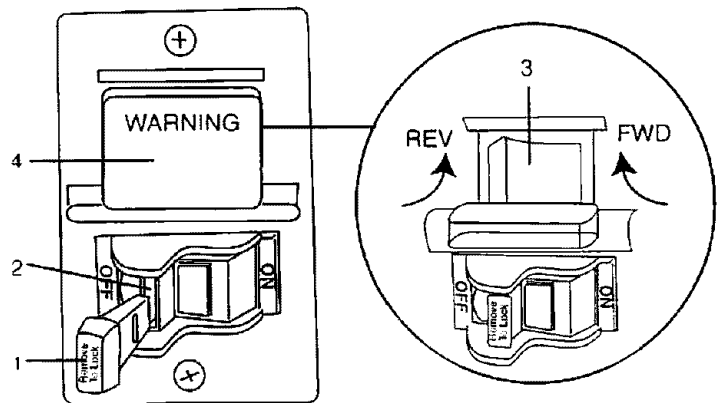

### FORWARD / REVERSE SWITCH (FIG. Q)

A forward / reverse switch (3) is located above the power switch on the front of the shaper / router. This switch reverses the direction of the cutters to work from left to right or from right to left, increasing the wood shaping versatility.

1. To reverse the cutter direction from counterclockwise (right to left) to clockwise (left to right), or vice versa, turn the tool OFF and lower the plastic switch door (4) to expose the switch (3).
2. Depress the left side of the switch for a counterclockwise rotation. Depress the right side for a clockwise rotation.
3. BE SURE TO TURN THE CUTTER OVER to cut in the opposite direction when changing the rotation direction. The workpiece must always be fed against the direction of cutter rotation.
4. Close the switch cover before turning the tool ON.

**NOTE:** Only shapers that can be inverted can be used for left to right cutting. Router bits cannot be inverted and must cut from right to left.

### ⚠ WARNING

To avoid sudden reversal and possible injury, be sure to close the direction switch cover before using the tool.

## OPERATION

### ⚠ WARNING

For your own safety, do not plug the tool into the power source receptacle or insert the switch key, until the parts are correctly installed and adjustments have been made.

### ⚠ WARNING

To avoid possible injury, keep the guard in place and in working order when operating the tool.

### ⚠ WARNING

For your safety, use only shaper cutters and router bits sized and recommended for this shaper / router. Follow instructions that accompany the cutters.

### ON / OFF SWITCH (FIG. Q)

The keyed switch is intended to prevent unauthorized use of the shaper / router.

1. To turn the shaper / router ON insert the yellow key (1) into the key slot (2) in the center of the switch.
2. Push the key firmly into the slot, then push switch to the ON position to start the shaper / router.

## ▲ WARNING

To avoid injury:

1. **BE SURE** your cutter (1) is mounted so that the cutting face rotates toward the in-feed fence (2). If mounted upside down, the cutter can kick the wood back and injure the operator. (FIG. R)
2. **BE SURE** the keyed washer is installed directly under the jam nut.
3. **TIGHTEN** the jam nut before turning on the shaper / router.
4. **BE SURE** the table insert is installed and not in contact with the cutter.
5. **DRESS PROPERLY.** Do not wear gloves, jewelry, necktie, long sleeves, or loose clothing.
6. **WEAR SAFETY** goggles that comply with ANSI Z87.1, and wear a face mask if operation is dusty.
7. **EXAMINE** the mounting surface to be sure the tool is stable, with no movement.
8. **BE SURE** the guard is in place and locked 1/4" above the workpiece.

Fig. R

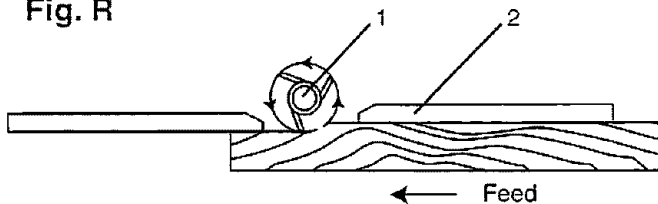

## PREPARING THE WORKPIECE

Cut the workpiece as close to the final size as possible before shaping. The shaper / router should not be used to reduce the size of the workpiece. The spindle speed (RPM) may be reduced if the cutter is required to make a heavy cut, resulting in a rough or splintered cut. Always make a test cut on a piece of scrap before shaping the final workpiece.

## ▲ WARNING

Excessive depth of cut can cause kickback and possible injury.

## WOOD GRAIN

With most woods, cutting with or against the direction of grain makes little difference, since the shaper / router runs at a very high RPM. Shaping very open grained woods, such as fir or redwood, may result in a rough, splintered surface. It is advisable to make a series of light cuts. The final cuts should remove 1/16" or less.

## ACROSS THE GRAIN

Cross-grain cuts will result in splintering the back edge. There are two ways to reduce this problem:

1. Cut the workpiece 1/4" oversize and trim after shaping.
2. Clamp a piece of scrap to the trailing edge of the workpiece.

## LARGE WORKPIECES

For very long, wide, or irregularly shaped workpieces:

1. Add an extension to the sides and front of the table.
2. Use only smooth flat wood, and be sure the extension is on the same level as the shaper / router table.
3. Replace the fence boards with longer or higher fence extensions to provide more support.

## STRAIGHT EDGE SHAPING OR ROUTING (FIG. S, T, U)

The fence should always be used if the type of shaping work allows.

1. Draw an outline of the desired cut profile on the end of the workpiece (1).
2. Align the fence faces with each other in a straight line and lock them in place.
3. Rotate the cutter (2) until one of the cutting faces is perpendicular to the fences.
4. Place the workpiece against the in-feed fence (3) and slide it against the face of the cutter to see the cutting profile. (FIG. S)

Fig. S

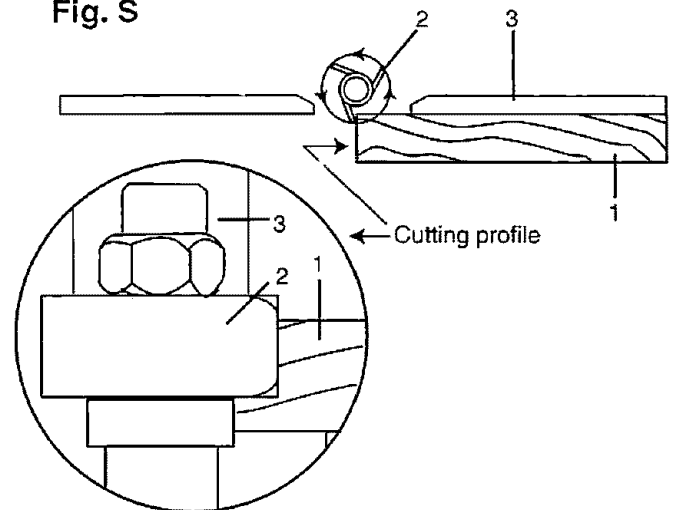

5. Adjust the spindle height and fence location to give the desired cut profile.
6. Try out the setting on a piece of scrap, and make final adjustments.
7. When about 2" of the test piece is adjacent to the out-feed (4) side of the fence, stop the shaper and turn the switch OFF. (FIG. T)

Fig. T

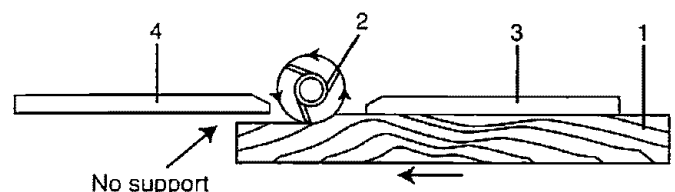

8. Clamp the test piece to the table so it will not move.
9. Loosen the three fence lock knobs holding the fence and fence sliding bracket.
10. Slide the fence faces until they support the work completely on both sides. (FIG. U)
11. Lock all knobs securely before turning the tool ON and resuming the test cut.

**Fig. U**

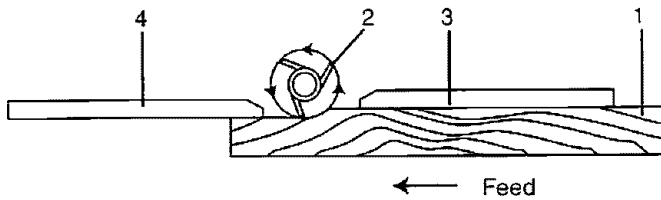

**NOTE:** When the cutter rotation is reversed, the feed direction will also be reversed. Therefore the in-feed (3) and out-feed (4) fence identification will also reverse.

12. Avoid heavy cuts. Begin by positioning the cutter and fence to remove only a small portion of the final cut form. Increase cutter exposure with each successive pass by moving the fence or the cutter height, until the desired form is cut. Taking too large a cut or feeding the workpiece too fast can cause damage to the workpiece and loss of control with possible injury.
13. When starting the shaping operation, apply pressure to the area supported by the in-feed fence (3), keeping your hands away from the cutter. When more than half of the workpiece has passed the cutter, transfer pressure to the area now supported by the out-feed fence (4).

**⚠ WARNING**

Never apply pressure to the workpiece in the area between the fences. This will cause the workpiece to kick in toward the cutter when the trailing edge leaves the infeed fence, causing loss of control and possible injury.

**CURVED EDGE SHAPING (FIG. V through AA)**

To shape an edge that is not straight, remove the sliding fence brackets and boards, and replace them with the starting pin and a collar. A collar or bearing guide **MUST** be used when cutting without a fence.

1. The collars (1) must be smooth and free of gum, pitch or other substances. Any irregularity on the collar will be reflected in the shaped surface.
2. The edge of the work to be shaped must be smooth. Any irregularity in the surface that rides against the collar will be reflected in the shaped surface.
3. The collars can be solid or ball bearing, and are mounted above or below the cutter on the spindle to set the depth of cut.
4. A portion of the edge of the workpiece (3) **MUST** remain untouched by the cutters (2) to give the collar (1) sufficient bearing surface. (FIG. V)
5. The workpiece **MUST** be wide in proportion to the cut being made. Short workpieces of narrow material should **NEVER** be shaped against the collars. (FIG. W)

**Fig. V**

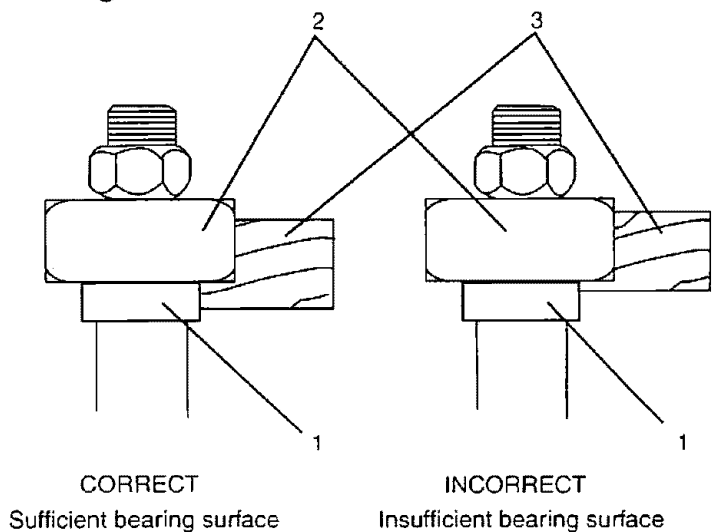

**Fig. W**

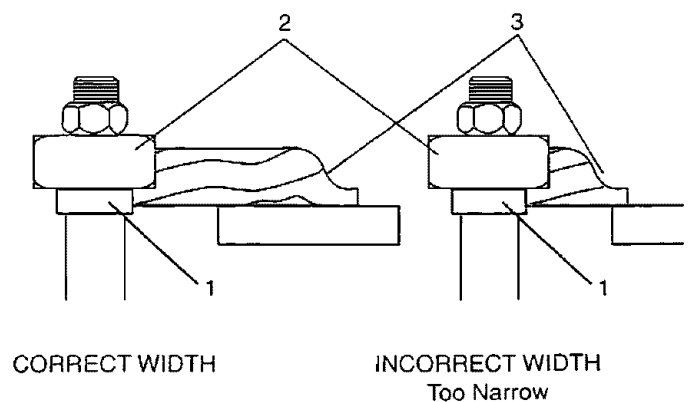



### To position the collars (FIG. X, Y, Z)

The collars may be used above, below, or between two cutters, according to the depth and pattern requirements.

1. When the collar (1) is placed below the cutter (2), the progress of the cut can be seen at all times. Accidental lifting of the workpiece (3) will gouge and ruin it. (FIG. X)
2. When the collar is used above the cutter, the cut cannot be seen, and the cut will not be affected by slight variations in the wood thickness. (FIG. Y)
3. When the collar is placed between two cutters, the cut has the benefits of both the above and below positions. This setup is frequently used when both edges of the work are shaped at the same time. (FIG. Z)

Fig. X

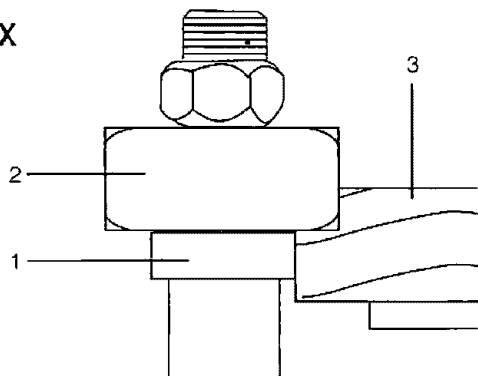

Fig. Y

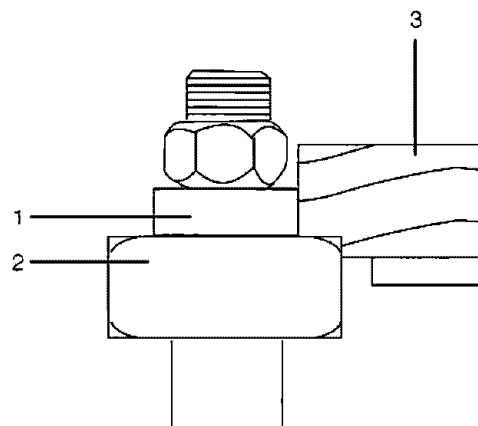
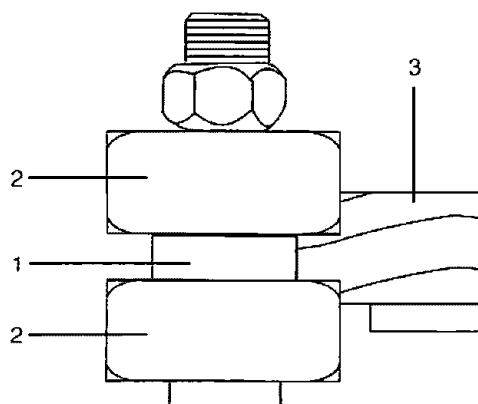

Fig. Z



### To feed the workpiece (FIG. AA)

The starting pin should be used as a support when starting the cut. Always feed against the rotation of the cutter.

1. Rest the workpiece against the starting pin (1) (**first position**). Feed straight into the cutter (2) until the finished edge is against the collar (3).
2. The workpiece is now supported by the collar and the starting pin (**second position**).
3. After the cut is started, the work is swung free of the starting pin and is supported only by the collar (**third position**).
4. Keep the edge being shaped at 90°, perpendicular, to the collar. Hold the workpiece firmly against the collar, and slowly feed around the shape until the cutting is complete.

### ▲ WARNING

Always use the starting pin. If the work advances to the cutter without the support of the starting pin, it will be kicked back and cause possible injury. Always feed against the rotation of the cutter.

Fig. AA

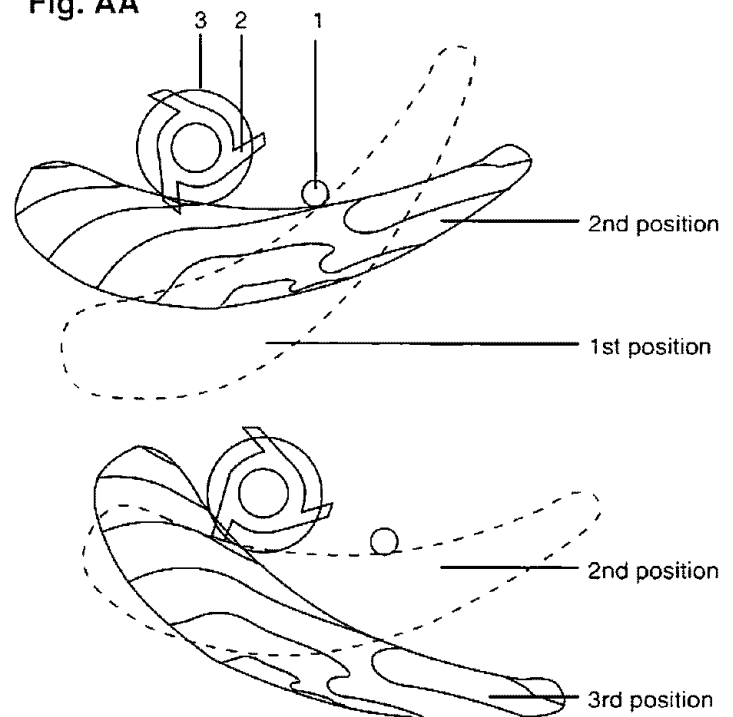

### Using a pattern when feeding

To make several pieces of the same shape:

1. Make a pattern or template from 1/4" scrap wood.
2. Allow for the diameter of the collar, the contour shape, and depth of cut when cutting the pattern.
3. Fasten the pattern to the workpiece using clamps, screws, brads, or rubber cement.
4. Feed the workpiece into the cutter until the collar contacts the pattern.
5. Slowly feed the workpiece around the pattern holding the pattern tight against the collar. Do any cross-grain cutting first, to prevent splintering on the finished workpiece.

## MAINTENANCE

### **▲ WARNING**

To avoid fire or toxic reaction, never use gasoline, naphtha, acetone, lacquer thinner, or similar highly volatile solvents to clean the shaper / router.

### **▲ WARNING**

For your safety, this shaper / router is double-insulated. To avoid electrical shock, fire, or injury, use only parts identical to those identified in the parts list. Reassemble exactly as the original assembly to avoid electrical shock.

## GENERAL MAINTENANCE

Keep your shaper / router clean and adjusted properly for maximum performance and machine longevity. Do not allow pitch or gums to accumulate on the table, fences, or cutters. Clean bits and cutters frequently with a good quality gum and pitch remover.

Frequently blow out using an air compressor or dust vacuum, any dust that accumulates inside the motor.

Apply a light coat of automotive paste wax to the table top and the fence faces to reduce friction during shaping, and to protect the surfaces.

### **▲ WARNING**

Do not allow brake fluids, gasoline, or penetrating oils to come in contact with plastic parts. They contain chemicals that can damage or destroy plastics.

## LUBRICATION

The shaper / router spindle shaft ball bearings are permanently lubricated at the factory. No further lubrication is required.

# TROUBLESHOOTING

## TROUBLESHOOTING GUIDE

### **▲ WARNING**

Turn switch OFF and always remove plug from power source before making any adjustments or repairs.

### **▲ WARNING**

All electrical or mechanical repairs should be done only by qualified service technicians. Contact the nearest Sears Service Center.

PROBLEM	PROBABLE CAUSE	SUGGESTED CORRECTIVE ACTION
Cutter does not come up to speed.	<ol style="list-style-type: none"> <li>1. Extension cord too light or too long.</li> <li>2. Low house current or overloaded circuit.</li> </ol>	<ol style="list-style-type: none"> <li>1. Replace with adequate size cord.</li> <li>2. Reduce load on circuit or contact your electric company.</li> </ol>
Cutter slows down during operation.	<ol style="list-style-type: none"> <li>1. Feeding stock too fast.</li> <li>2. Attempting to remove too much material.</li> <li>3. Cutter in poor condition (gummed or dull).</li> </ol>	<ol style="list-style-type: none"> <li>1. Decrease feed speed.</li> <li>2. Decrease depth of cut, make two or more cuts.</li> <li>3. Clean or replace cutter.</li> </ol>
Machine vibrates excessively.	<ol style="list-style-type: none"> <li>1. Machine not mounted to workbench securely.</li> <li>2. Workbench is on uneven floor.</li> <li>3. Damaged cutter.</li> </ol>	<ol style="list-style-type: none"> <li>1. Tighter all mounting hardware.</li> <li>2. Reposition on flat, level surface.</li> <li>3. Replace cutter.</li> </ol>
Unsatisfactory cuts.	<ol style="list-style-type: none"> <li>1. Dull cutter.</li> <li>2. Feeding work in wrong direction.</li> <li>3. Gum or pitch on cutter.</li> <li>4. Gum or pitch on table causing erratic feed.</li> </ol>	<ol style="list-style-type: none"> <li>1. Replace cutter.</li> <li>2. Feed work against the cutter rotation.</li> <li>3. Remove cutter and clean with Gum and Pitch Remover.</li> <li>4. Clean table with Gum and Pitch Remover.</li> </ol>
Excessive gouging at end of cuts.	<ol style="list-style-type: none"> <li>1. Fence bracket not properly set.</li> <li>2. Work not held firmly against fence.</li> </ol>	<ol style="list-style-type: none"> <li>1. Reset fence bracket.</li> <li>2. Hold work firmly against the out-feed fence.</li> </ol>
Chip discharge clogs.	<ol style="list-style-type: none"> <li>1. Obstruction is reducing the air flow.</li> <li>2. Cutter speed is too slow.</li> <li>3. Wood has a high moisture content.</li> <li>4. Cutter is too small to exhaust the chips.</li> </ol>	<ol style="list-style-type: none"> <li>1. Remove the obstruction.</li> <li>2. Decrease the feed speed.</li> <li>3. Decrease the feed speed.</li> <li>4. Attach a Wet / Dry Vac to the chip discharge.</li> </ol>

# PARTS

## CRAFTSMAN SHAPER / ROUTER

137.217100

### ▲ WARNING

When servicing use only CRAFTSMAN replacement parts. Use of any other parts may create a HAZARD or cause product damage.

### ▲ WARNING

Any attempt to repair or replace electrical parts on this shaper / router may create a HAZARD unless repair is done by a qualified service technician. Repair service is available at your nearest Sears Service Center.

Order by PART NUMBER, not by key number

Key No.	Part No.	Description	Size	Qty.	Key No.	Part No.	Description	Size	Qty.
1	14115501	Hex. wrench		1	47	18310201	Lock knob		2
2	18300202	Hex. wrench		1	48	14943302	Connector		1
3	2807CT062D	Power cord		1	49	2501NBDN25	Flat washer	5/16x11/16-1/16	2
4	2701FBD104	Hex. nut	M4x0.7	2	50	16932802	Lock knob		2
5	2641BBDA43	Round washer hd. screw	M6x1.0-30	4	51	18310701	Support rod		1
6	2801ABRF01	Strain relief		1	52	18310801	Extension plate		1
7	83990121	Cord clamp		1	53	2501NBDN25	Flat washer	5/16x11/16-1/16	1
8	2668BBDA12	Round washer hd. screw	M4x0.7-20	2	54	18311001	Lock knob		1
					55	2701FBD104	Hex. nut	M4x0.7	2
					56	14106403	Cutter guard		1
9	18301001	Nut		1	57	2668BBDA09	Pan hd. screw	M4x0.7-12	2
10	14116101	Elbow		1	58	2701FBD106	Hex. nut	M6x1.0	4
11	8381028204	Motor		1	59	18311501	Sliding fence bracket		1
12	18301301	Nut		1	60	2501NBDN16	Flat washer	1/4x3/4-1/64	5
13	18301401	Spindle		1	61	18311801	Fence board		2
14	14107501	Washer		1	62	2636BBDA42	Count hd. screw	M6x1.0-25	4
15	14107401	Hex. nut		1	63	18312101	Table insert		1
16	18402702	Foot		4	64	18312001	Pin		1
17	14112305	Washer	D=20.6 d=12.7	1	65	18312202	Sheet bar		1
18	14112304	Washer	D=22.2 d=12.7	1	66	14608001	Pin		1
19	14112303	Washer	D=30.1 d=12.7	1	67	14911402	Miter gauge		1
20	14112302	Washer	D=29.4 d=12.7	1	68	2501NZDN16	Flat washer	1/4x3/4-1/64	1
21	14112301	Washer	D=33 d=12.7	1	69	14911602	Knob		1
22	2801UBHA07	Strain relief		2	70	2608BBLA32	Hex. soc. truss hd. screw		2
23	14018102	Switch box		1	71	2603BBLA38	Hex. soc. set screw	M6x1.0-10	1
24	18302505	Switch cover		1	72	14911802	Angle pointer		1
25	2661MBDE08	Truss hd. tapping screw	M3.5x18-16	2	73	18305301	Label		1
26	2898DB7G12	Switch		1	74	18313301	Scale		2
27	18302803	Handle bar		1					
28	18302901	Flat washer		1	75	2638BBDA41	Round washer hd. screw	M6x1.0-18	2
29	18303001	Bush		1	76	16314301	Power cord clamp		2
30	18303104	Body shell		1	77	2708FBD107	Serrated toothed hex. flange nut	M6x1.0	2
31	2615BBOC26	Hex. hd. screw and washer	M8x1.25-30	3	78	14523301	Compression spring		1
32	2852E55514	Switch		1	79	29835L5006	Steel ball		1
33	18303401	Spindle support		1	*	13721710001	Owner's manual		1
34	18303501	Bearing cover		1	56A	14106403A11	Cutter guard assembly		1
35	2668BBDA23	Pan hd. screw	M5x0.8-8	2	67A	14911402A4	Miter gauge assembly		1
36	18303702	Table		1					
37	18303806	Label		1					
38	18304001	Plate cover		1					
39	18304101	Pivot shaft		1					
40	29065558Q3	Lead wire assembly		1					
41	2806555H05	Lead wire assembly		1					
42	18304403	Elbow		1					
43	280955HA01	Locking cable tie		1					
44	18304603	Warning label		1					
45	286058H071	Switch key		1					
46	18310101	Backstop		1					

\* Not shown

