

ASSEMBLY

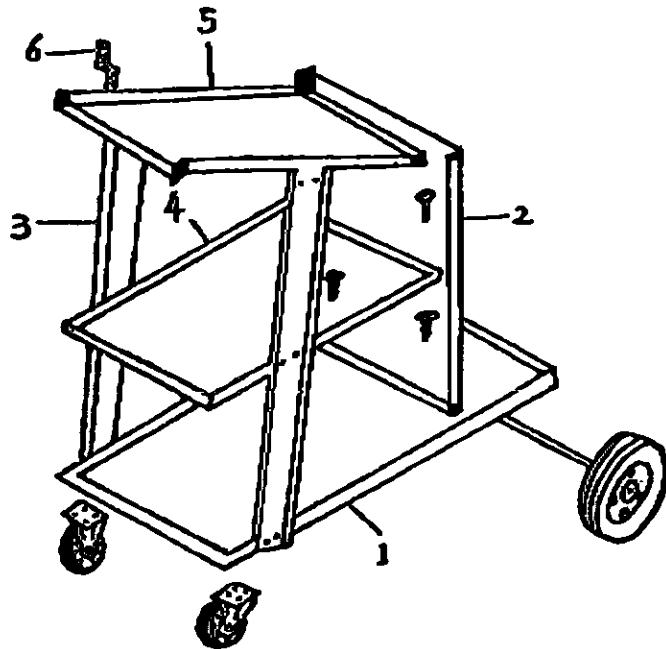

1. Slide axle through support tube on bottom of shelf (1). Slip washers over both ends of axle, fit wheels onto axle, insert cotter pins, and finish by adding plastic cap on end of axle.

2. Install casters to front of shelf (1) using 4 hex head screws and washers to one side of shelf and 4 lockwashers and hex nuts to other side of shelf. Finger tight all screws and nuts until complete.

3. Add vertical support (2) to bottom of shelf (1). Fasten through center hole of vertical support first. Then fasten through side holes in bottom of vertical support.

4. Fasten side support rails (3) to bottom shelf. Add center shelf (4) with flanges up. Start by fastening center hole towards rear of shelf then side holes in rear of shelf, finally front side holes to side support rails.

5. Fasten top shelf (5) in similar fashion, but include brackets (6) for cord storage to top front holes in side support rails. Now tighten all fasteners.

Parts list for assembly of Cat # 22380 Mig Welding Cart

Description	Qty.	Description	Qty.
1. Bottom shelf w/axle tube	1	6. Brackets for torch assembly	2
Wheels	2	7. Hex screws, nuts, washers, 10 lockwashers	10
Casters	2		
Washers	2		
2. Vertical support panel	1		
3. Side support rails	2		
4. Center shelf all sides flanged	1		
5. Top shelf 3 sides flanged upward	1		

WE7000B - MIG Welder Cart

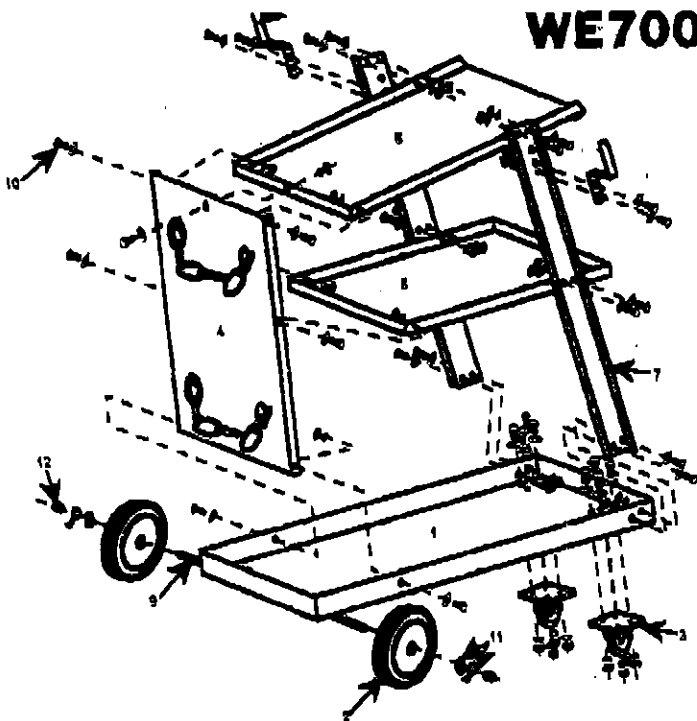

WARNING

1. Cart is designed to carry one gas cylinder for use with MIG welding. Use caution when handling compressed gas cylinders and use only in upright position. Use supplied chains to secure the top and bottom of gas cylinder to cart as tightly as possible.
2. Never attempt to weld the gas cylinder.
3. Cart is designed to roll easily on flat surfaces. Cart should not be used on sloped surfaces.
4. Cart can be easily maneuvered by grasping the top shelf and steering cart into desired position. Use caution when moving cart as weight of welder could cause cart to be top heavy.
5. Do not pull cart by welder's gun cable or ground cable as this could cause cart to tip over.
6. Do not fasten ground clamp to welder cart as this could complete the welding circuit, which could cause the gun to arc unexpectedly.
7. Failure to follow precautions could cause serious injury.

PARTS LIST

ITEM NUMBER	DESCRIPTION	QTY
WE7000B-001	BOTTOM SHELF	1
WE7000B-002	WHEELS	2
WE7000B-003	CASTORS	2
WE7000B-004	VERTICAL SUPPORT	1
WE7000B-005	CENTER SHELF	1
WE7000B-006	TOP SHELF	1

ITEM NUMBER	DESCRIPTION	QTY
WE7000B-007	SUPPORT RAILS	2
WE7000B-008	CABLE BRACKETS	2
WE7000B-009	AXLE	1
WE7000B-010	NUTS, BOLTS, WASHERS	32
WE7000B-011	FLAT WASHERS/COTTER PINS	2
WE7000B-012	PLASTIC CAP	2

ASSEMBLY

*You will need a 10mm metric wrench and a pair of pliers.

REAR WHEELS

1. Slide axle through support tube on bottom of lower shelf.
2. Slip washers over both ends of axle.
3. Fit wheels onto axle.
4. Insert cotter pins into holes at either end of axle and bend in place.
5. Slide red plastic caps firmly into place on each end of axle.

FRONT WHEELS

1. Align castor with 4 holes at left front of bottom shelf.
2. From top of shelf, insert a bolt with flat washer through each hole.
3. Slide one lock washer onto each bolt.
4. Firmly tighten nut onto each bolt with 10mm wrench.
5. Repeat steps 1-4 for right side castor.

VERTICAL SUPPORT

1. Align the bottom holes in the sides of the vertical support with the holes in the sides of bottom shelf. (Note: lip of vertical support should be facing the front of the welder cart.)
2. From top of shelf, insert a bolt with flat washer through center hole of vertical support and bottom shelf.
3. Slide one lock washer onto bolt (This may require you to lay the cart on its side).
4. Firmly tighten nut onto bolt with 10mm wrench.
5. From outside of shelf, insert a bolt with flat washer through each side hole of vertical support and bottom shelf.
6. Slide one lock washer onto each bolt.
4. Firmly tighten nut onto each bolt with 10mm wrench.

SUPPORT RAILS

1. Align left bottom support rail holes with holes on front left side of bottom shelf. (Note: Bottom of support rail has only 2 holes. Top of support rail has 5 holes.)
2. From outside of support rail, insert a with flat washer bolt through each hole.
3. Slide one lock washer onto each bolt.
4. Firmly tighten nut onto each bolt with 10mm wrench.
5. Repeat steps 1-4 for right side support rail.

CENTER SHELF

1. Align four front holes (two on either side) of center shelf with four center holes (two on either side) of support rails. (Note: Center shelf has four lipped sides. Lip should be facing upwards when installing.)
2. From outside of support rail, insert a bolt with flat washer through each hole.
3. Align holes (one on either side) in rear lip of center shelf with center holes (one on either side) of vertical support.
4. Slide one lock washer onto each bolt.
5. Firmly tighten nut onto each bolt with 10mm wrench.

TOP SHELF

1. Align four front holes (two on either side) of top shelf with four center holes (two on either side) of support rails. (Note: Top shelf has three lipped sides. Lip should be facing upwards when installing.)
2. From outside of support rail, insert a bolt with flat washer through each hole.
3. Align two rear holes (one on either side) of top shelf with upper holes (one on either side) of vertical support.
4. From outside of vertical support, insert a bolt with flat washer through each hole.
5. Align hole in rear lip of top shelf with top center hole in vertical support.
6. From outside of vertical support, insert a bolt with flat washer through hole.
7. Slide one lock washer onto each bolt.
8. Firmly tighten nut onto each bolt with 10mm wrench.

CABLE BRACKETS

1. Align holes on cable bracket with vertically aligned holes on support rails.
2. From outside of cable bracket, insert a bolt with flat washer through each hole.
3. Slide one lock washer onto each bolt.
4. Firmly tighten nut onto each bolt with 10mm wrench.