

Operator's Manual

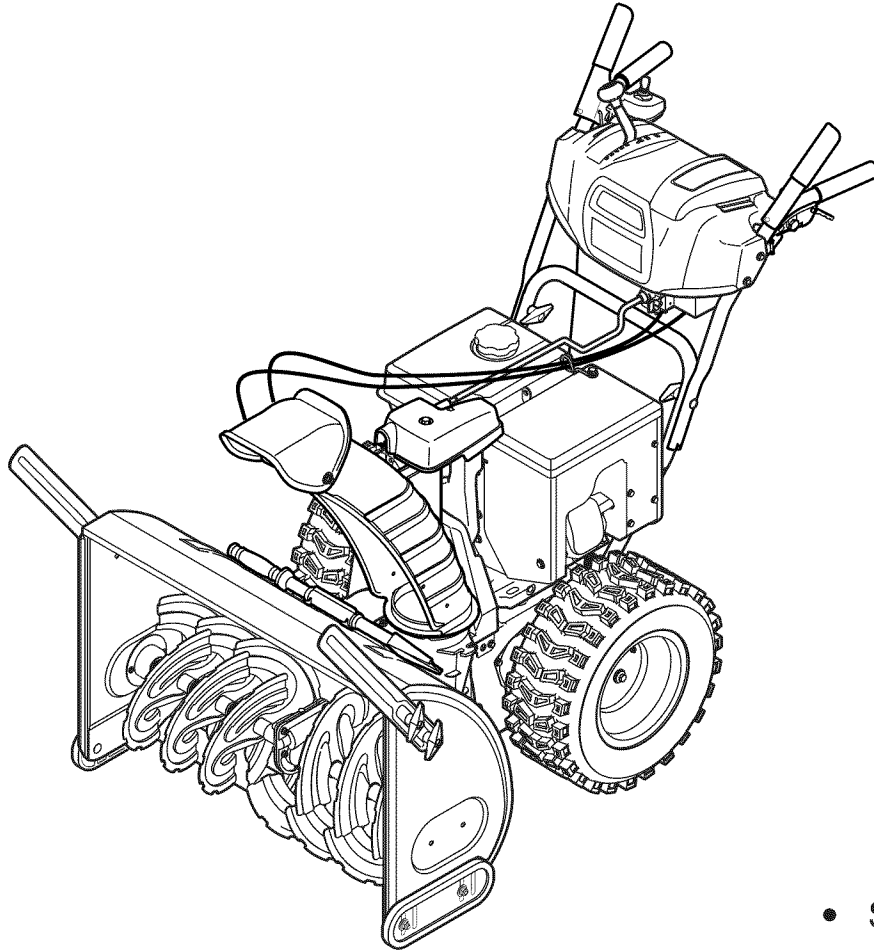

30" SNOW THROWER

Model No. 247.883961



CAUTION: Before using this product, read this manual and follow all safety rules and operating instructions.

- SAFETY
- ASSEMBLY
- OPERATION
- MAINTENANCE
- PARTS LIST
- ESPAÑOL

Sears Brands Management Corporation, Hoffman Estates, IL 60179, U.S.A.

Visit our website: www.craftsman.com

Form No. 769-08184C
(June 21, 2013)

TABLE OF CONTENTS

Warranty Statement.....	Page 2	Off-Season Storage.....	Page 24
Safe Operation Practices	Pages 3-6	Troubleshooting	Page 26
Assembly	Pages 8-12	Parts List.....	Pages 28-44
Operation	Pages 13-17	Repair Protection Agreement.....	Page 47
Service & Maintenance	Pages 18-23	Español.....	Page 48

WARRANTY STATEMENT

CRAFTSMAN TWO YEAR FULL WARRANTY

FOR TWO YEARS from the date of purchase, this product is warranted against any defects in material or workmanship. Defective product will receive free repair or free replacement if repair is unavailable.

ADDITIONAL LIFETIME LIMITED WARRANTY on UPPER and LOWER CHUTE

FOR AS LONG AS IT IS USED by the original owner after the second year from the date of purchase, the upper and lower chute of this snow thrower are warranted against any defects in material or workmanship as verified by a Sears authorized service provider. With proof of purchase, you will receive a new chute free of charge. You are responsible for the labor cost of installation and any cost incurred to verify the defect.

For warranty coverage details to obtain repair or replacement, visit the web site: www.craftsman.com

This warranty covers ONLY defects in material and workmanship. Warranty coverage does NOT include:

- Expendable items that can wear out from normal use within the warranty period, including but not limited to augers, auger paddles, drift cutters, skid shoes, shave plate, shear pins, spark plug, air cleaner, belts, and oil filter.
- Standard maintenance servicing, oil changes, or tune-ups.
- Tire replacement or repair caused by punctures from outside objects, such as nails, thorns, stumps, or glass.
- Tire or wheel replacement or repair resulting from normal wear, accident, or improper operation or maintenance.
- Repairs necessary because of operator abuse, including but not limited to damage caused by over-speeding the engine, or from impacting objects that bend the frame, auger shaft, etc.
- Repairs necessary because of operator negligence, including but not limited to, electrical and mechanical damage caused by improper storage, failure to use the proper grade and amount of engine oil, or failure to maintain the equipment according to the instructions contained in the operator's manual.
- Engine (fuel system) cleaning or repairs caused by fuel determined to be contaminated or oxidized (stale). In general, fuel should be used within 30 days of its purchase date.
- Normal deterioration and wear of the exterior finishes, or product label replacement.

This warranty is void if this product is ever used while providing commercial services or if rented to another person.

This warranty gives you specific legal rights, and you may also have other rights which vary from state to state.

Sears Brands Management Corporation, Hoffman Estates, IL 60179

PRODUCT SPECIFICATIONS

Engine Oil: 5W-30
Fuel: Unleaded Gasoline
Engine: MTD

MODEL NUMBER

Model Number _____
Serial Number _____
Date of Purchase _____

Record the model number, serial number,
and date of purchase above.

SAFETY INSTRUCTIONS

WARNING

This symbol points out important safety instructions which, if not followed, could endanger the personal safety and/or property of yourself and others. Read and follow all instructions in this manual before attempting to operate this machine. Failure to comply with these instructions may result in personal injury. When you see this symbol, **HEED ITS WARNING!**

WARNING

CALIFORNIA PROPOSITION 65

Engine Exhaust, some of its constituents, and certain vehicle components contain or emit chemicals known to State of California to cause cancer and birth defects or other reproductive harm.

DANGER

This machine was built to be operated according to the safe operation practices in this manual. As with any type of power equipment, carelessness or error on the part of the operator can result in serious injury. This machine is capable of amputating fingers, hands, toes and feet and throwing debris. Failure to observe the following safety instructions could result in serious injury or death.

WARNING

Your Responsibility—Restrict the use of this power machine to persons who read, understand and follow the warnings and instructions in this manual and on the machine.

SAVE THESE INSTRUCTIONS!

TRAINING

- Read, understand, and follow all instructions on the machine and in the manual(s) before attempting to assemble and operate. Failure to do so can result in serious injury to the operator and/or bystanders. Keep this manual in a safe place for future and regular reference and for ordering replacement parts.
- Be familiar with all controls and their proper operation. Know how to stop the machine and disengage them quickly.
- Never allow children under 14 years of age to operate this machine. Children 14 and over should read and understand the instructions and safe operation practices in this manual and on the machine and be trained and supervised by an adult.
- Never allow adults to operate this machine without proper instruction.
- Thrown objects can cause serious personal injury. Plan your snow-throwing pattern to avoid discharge of material toward roads, bystanders and the like.
- Keep bystanders, pets and children at least 75 feet from the machine while it is in operation. Stop machine if anyone enters the area.
- Exercise caution to avoid slipping or falling, especially when operating in reverse.

PREPARATION

- Thoroughly inspect the area where the equipment is to be used. Remove all doormats, newspapers, sleds, boards, wires and other foreign objects, which could be tripped over or thrown by the auger/impeller.
- Always wear safety glasses or eye shields during operation and while performing an adjustment or repair to protect your eyes. Thrown objects which ricochet can cause serious injury to the eyes.
- Do not operate without wearing adequate winter outer garments. Do not wear jewelry, long scarves or other loose clothing, which could become entangled in moving parts. Wear footwear which will improve footing on slippery surfaces.
- Use a grounded three-wire extension cord and receptacle for all machines with electric start engines.

- Disengage all control levers before starting the engine.
- Adjust collector housing height to clear gravel or crushed rock surfaces.
- Never attempt to make any adjustments while engine is running, except where specifically recommended in the operator's manual.
- Let engine and machine adjust to outdoor temperature before starting to clear snow.

Safe Handling of Gasoline:

To avoid personal injury or property damage use extreme care in handling gasoline. Gasoline is extremely flammable and the vapors are explosive. Serious personal injury can occur when gasoline is spilled on yourself or your clothes which can ignite. Wash your skin and change clothes immediately.

- Use only an approved gasoline container.
- Never fill containers inside a vehicle or on a truck or trailer bed with a plastic liner. Always place containers on the ground away from your vehicle before filling.
- When practical, remove gas-powered equipment from the truck or trailer and refuel it on the ground. If this is not possible, then refuel such equipment on a trailer with a portable container, rather than from a gasoline dispenser nozzle.
- Keep the nozzle in contact with the rim of the fuel tank or container opening at all times until fueling is complete. Do not use a nozzle lock-open device.
- Extinguish all cigarettes, cigars, pipes and other sources of ignition.
- Never fuel machine indoors.
- Never remove gas cap or add fuel while the engine is hot or running. Allow engine to cool at least two minutes before refueling.
- Never over fill fuel tank. Fill tank to no more than ½ inch below bottom of filler neck to allow space for fuel expansion.
- Replace gasoline cap and tighten securely.
- If gasoline is spilled, wipe it off the engine and equipment. Move unit to another area. Wait 5 minutes before starting the engine.

SAFETY INSTRUCTIONS

- To reduce fire hazards, keep machine free of grass, leaves, or other debris build-up. Clean up oil or fuel spillage and remove any fuel soaked debris.
- Never store the machine or fuel container inside where there is an open flame, spark or pilot light as on a water heater, space heater, furnace, clothes dryer or other gas appliances.

OPERATION

- Do not put hands or feet near rotating parts, in the auger/impeller housing or chute assembly. Contact with the rotating parts can amputate hands and feet.
- The auger/impeller control lever is a safety device. Never bypass its operation. Doing so makes the machine unsafe and may cause personal injury.
- The control levers must operate easily in both directions and automatically return to the disengaged position when released.
- Never operate with a missing or damaged chute assembly. Keep all safety devices in place and working.
- Never run an engine indoors or in a poorly ventilated area. Engine exhaust contains carbon monoxide, an odorless and deadly gas.
- Do not operate machine while under the influence of alcohol or drugs.
- Muffler and engine become hot and can cause a burn. Do not touch. Keep children away.
- Exercise extreme caution when operating on or crossing gravel surfaces. Stay alert for hidden hazards or traffic.
- Exercise caution when changing direction and while operating on slopes. Do not operate on steep slopes.
- Plan your snow-throwing pattern to avoid discharge towards windows, walls, cars etc. Thus, avoiding possible property damage or personal injury caused by a ricochet.
- Never direct discharge at children, bystanders and pets or allow anyone in front of the machine.
- Do not overload machine capacity by attempting to clear snow at too fast of a rate.
- Never operate this machine without good visibility or light. Always be sure of your footing and keep a firm hold on the handles. Walk, never run.
- Disengage power to the auger/impeller when transporting or not in use.
- Never operate machine at high transport speeds on slippery surfaces. Look down and behind and use care when backing up.
- If the machine should start to vibrate abnormally, stop the engine, disconnect the spark plug wire and ground it against the engine. Inspect thoroughly for damage. Repair any damage before starting and operating.
- Disengage all control levers and stop engine before you leave the operating position (behind the handles). Wait until the auger/impeller comes to a complete stop before unlogging the chute assembly, making any adjustments, or inspections.
- Never put your hand in the discharge or collector openings. Do not unlog chute assembly while engine is running. Shut off engine and remain behind handles until all moving parts have stopped before unlogging.

- Use only attachments and accessories approved by the manufacturer (e.g. wheel weights, tire chains, cabs etc.).
- When starting engine, pull cord slowly until resistance is felt, then pull rapidly. Rapid retraction of starter cord (kickback) will pull hand and arm toward engine faster than you can let go. Broken bones, fractures, bruises or sprains could result.
- If situations occur which are not covered in this manual, use care and good judgment.

CLEARING A CLOGGED DISCHARGE CHUTE

Hand contact with the rotating impeller inside the discharge chute is the most common cause of injury associated with snow throwers. Never use your hand to clean out the discharge chute.

To clear the chute:

- a. SHUT THE ENGINE OFF!
- b. Wait 10 seconds to be sure the impeller blades have stopped rotating.
- c. Always use a clean-out tool, not your hands.

MAINTENANCE & STORAGE

- Never tamper with safety devices. Check their proper operation regularly. Refer to the maintenance and adjustment sections of this manual.
- Before cleaning, repairing, or inspecting machine disengage all control levers and stop the engine. Wait until the auger/impeller come to a complete stop. Disconnect the spark plug wire and ground against the engine to prevent unintended starting.
- Check bolts and screws for proper tightness at frequent intervals to keep the machine in safe working condition. Also, visually inspect machine for any damage.
- Do not change the engine governor setting or over-speed the engine. The governor controls the maximum safe operating speed of the engine.
- Snow thrower shave plates and skid shoes are subject to wear and damage. For your safety protection, frequently check all components and replace with original equipment manufacturer's (OEM) parts only as listed in the Parts pages of this operator's manual. Use of parts which do not meet the original equipment specifications may lead to improper performance and compromise safety!
- Check control levers periodically to verify they engage and disengage properly and adjust, if necessary. Refer to the adjustment section in this operator's manual for instructions.
- Maintain or replace safety and instruction labels, as necessary.
- Observe proper disposal laws and regulations for gas, oil, etc. to protect the environment.
- Prior to storing, run machine a few minutes to clear snow from machine and prevent freeze up of auger/impeller.
- Never store the machine or fuel container inside where there is an open flame, spark or pilot light such as a water heater, furnace, clothes dryer etc.
- Always refer to the operator's manual for proper instructions on off-season storage.

SAFETY INSTRUCTIONS

- Check fuel line, tank, cap, and fittings frequently for cracks or leaks. Replace if necessary.
- Do not crank engine with spark plug removed.
- According to the Consumer Products Safety Commission (CPSC) and the U.S. Environmental Protection Agency (EPA), this product has an *Average Useful Life* of seven (7) years, or 60 hours of operation. At the end of the *Average Useful Life* have the machine inspected annually by an authorized service dealer to ensure that all mechanical and safety systems are working properly and not worn excessively. Failure to do so can result in accidents, injuries or death.

DO NOT MODIFY ENGINE

To avoid serious injury or death, do not modify engine in any way. Tampering with the governor setting can lead to a runaway engine and cause it to operate at unsafe speeds. Never tamper with factory setting of engine governor.

NOTICE REGARDING EMISSIONS

Engines which are certified to comply with California and federal EPA emission regulations for SORE (Small Off Road Equipment) are certified to operate on regular unleaded gasoline, and may include the following emission control systems: Engine Modification (EM), Oxidizing Catalyst (OC), Secondary Air Injection (SAI) and Three Way Catalyst (TWC) if so equipped.

SPARK ARRESTOR

WARNING

This machine is equipped with an internal combustion engine and should not be used on or near any unimproved forest-covered, brushcovered or grass-covered land unless the engine's exhaust system is equipped with a spark arrestor meeting applicable local or state laws (if any).







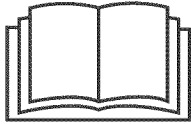

If a spark arrestor is used, it should be maintained in effective working order by the operator. In the State of California the above is required by law (Section 4442 of the California Public Resources Code). Other states may have similar laws. Federal laws apply on federal lands.

A spark arrestor for the muffler is available through your nearest Sears Parts and Repair Service Center.

SAFETY INSTRUCTIONS

SAFETY SYMBOLS

This page depicts and describes safety symbols that may appear on this product. Read, understand, and follow all instructions on the machine before attempting to assemble and operate.

Symbol	Description
	READ THE OPERATOR'S MANUAL(S) Read, understand, and follow all instructions in the manual(s) before attempting to assemble and operate
	WARNING— ROTATING BLADES Keep hands out of inlet and discharge openings while machine is running. There are rotating blades inside
	WARNING— ROTATING BLADES Keep hands out of inlet and discharge openings while machine is running. There are rotating blades inside
	WARNING— ROTATING AUGER Do not put hands or feet near rotating parts, in the auger/impeller housing or chute assembly. Contact with the rotating parts can amputate hands and feet.
	WARNING—THROWN OBJECTS This machine may pick up and throw and objects which can cause serious personal injury.
	WARNING— GASOLINE IS FLAMMABLE Allow the engine to cool at least two minutes before refueling.
	WARNING— CARBON MONOXIDE Never run an engine indoors or in a poorly ventilated area. Engine exhaust contains carbon monoxide, an odorless and deadly gas.
	WARNING— ELECTRICAL SHOCK Do not use the engine's electric starter in the rain
	WARNING— HOT SURFACE Engine parts, especially the muffler, become extremely hot during operation. Allow engine and muffler to cool before touching.



WARNING: Your Responsibility—Restrict the use of this power machine to persons who read, understand and follow the warnings and instructions in this manual and on the machine.

SAVE THESE INSTRUCTIONS!

This page left intentionally blank.

ASSEMBLY

NOTE: References to right or left side of the snow thrower are determined from behind the unit in the operating position (standing directly behind the snow thrower, facing the handle panel).

Removing From Carton

1. Cut the corners of the carton and lay the sides flat on the ground. Remove and discard all packing inserts.
2. Move the snow thrower out of the carton.
3. Make certain the carton has been completely emptied before discarding it.

Assembly

1. Observe the lower rear area of the snow thrower to be sure both cables are aligned with roller guides before pivoting the handle upward.
 - a. Place the shift lever in the F6 position.
 - b. Pull up and back on upper handle as shown in Figure 1. As you are raising the handle upward, make sure that both ends of the center cable are positioned properly in the brackets. See Figure 2. Align upper handle with the lower handle.
 - c. Tighten hand knobs securing upper handle to lower handle. Remove and discard any rubber bands, if present. They are for packaging purposes only.
2. Remove cotter pin, wing nut, and hex screw from chute control head and clevis pin and bow-tie cotter pin from chute support bracket. See Figure 3.

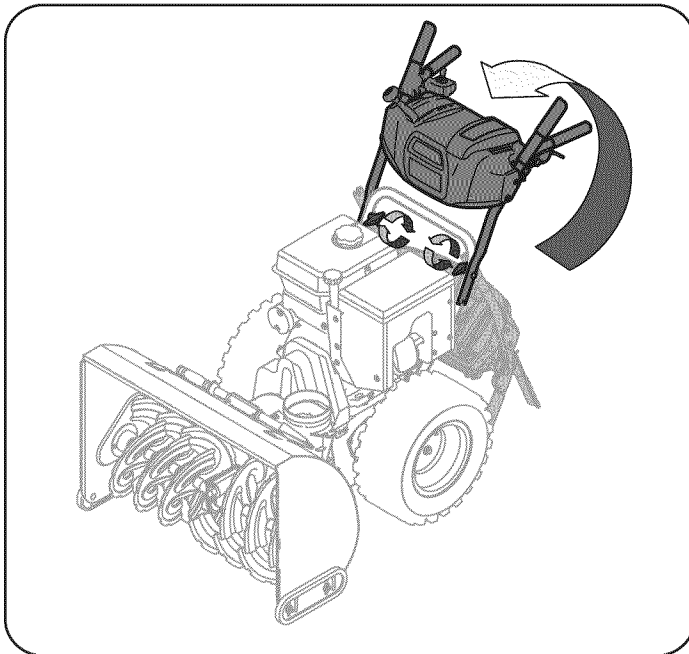

Figure 1

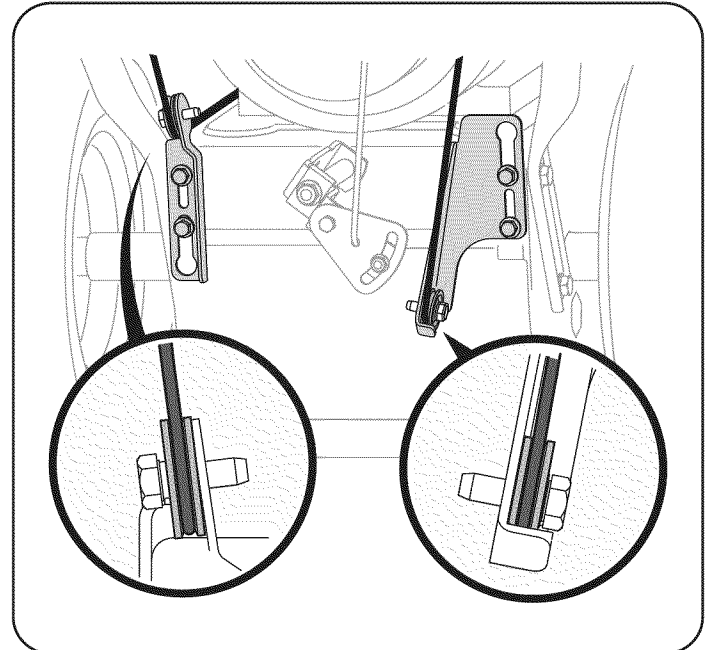

Figure 2

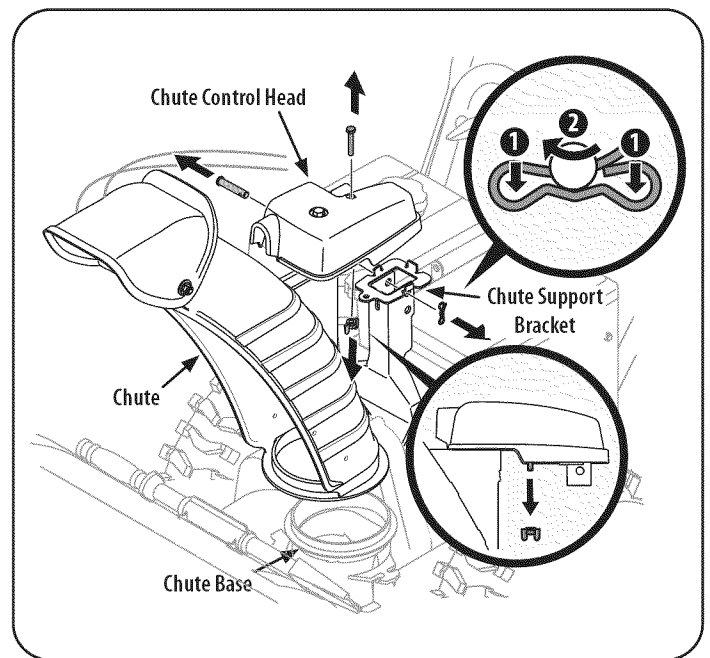

Figure 3

ASSEMBLY

3. Insert the round end of the chute control rod into input of chute control head. Push rod as far into the chute control head as possible, keeping the holes in the rod pointing upward. See Figure 4.
4. Place chute onto chute base and ensure chute control rod is positioned under handle panel. Secure chute control head to chute support bracket with clevis pin and bow-tie cotter pin removed in step 1. See Figure 5.
5. Finish securing chute control head by installing hex bolt and wing nut. See Figure 6.
6. Insert the other end of the chute control rod into the input shaft below the handle panel. Make sure to line up the flat end of the rod and the flat end of the input shaft. You may need to rotate the rod around until these two surfaces line up. See Figure 7.

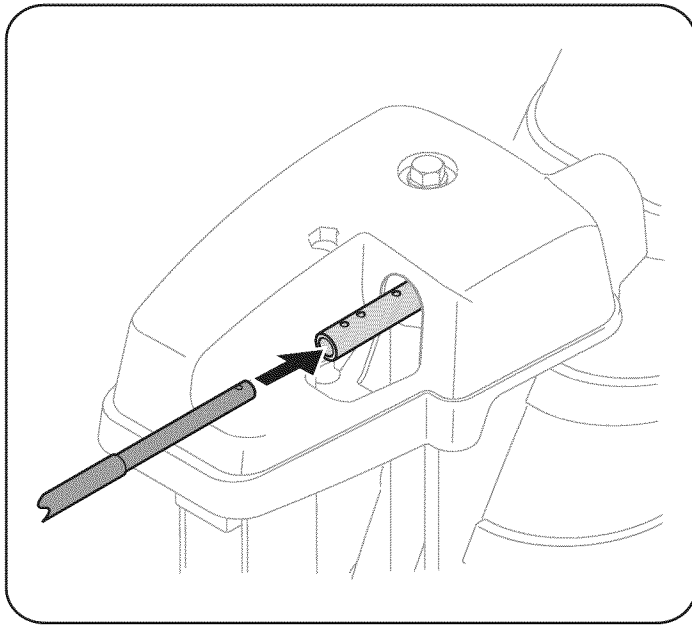

Figure 4

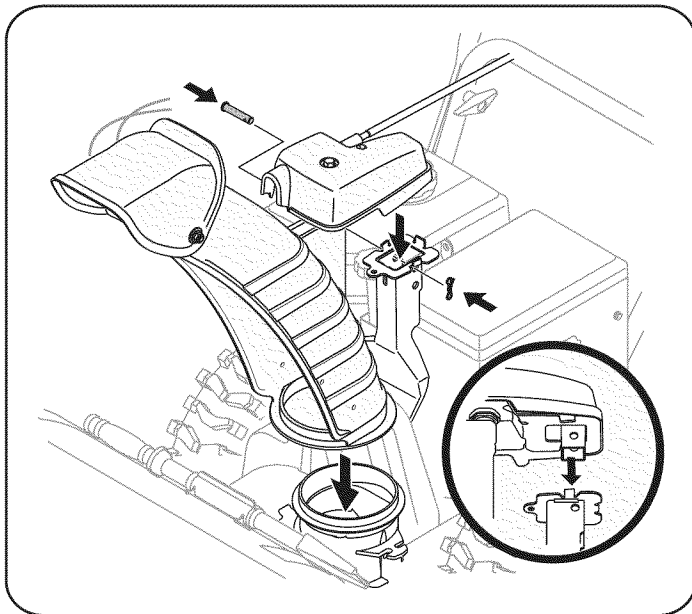

Figure 5

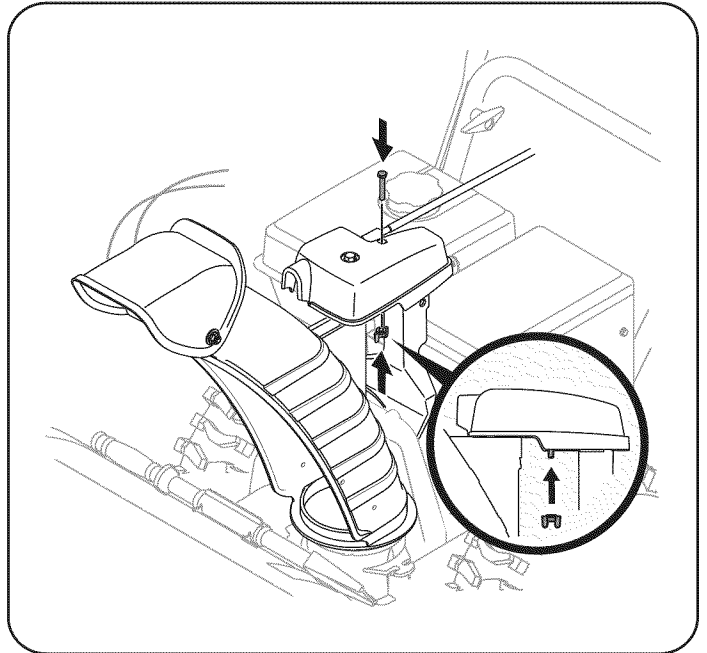

Figure 6

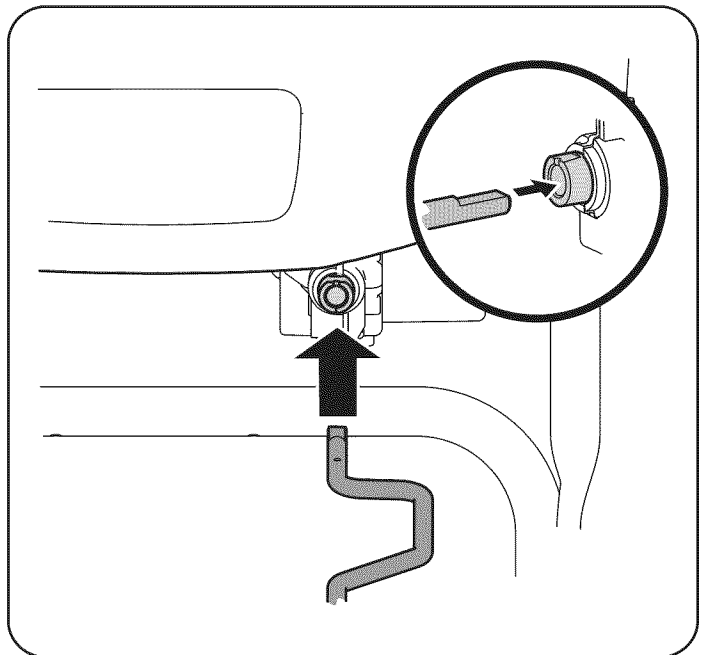

Figure 7

ASSEMBLY

7. Push the chute control rod toward the control panel until the hole in the rod lines up with the middle hole in the chute control input and insert the cotter pin. See Figure 8.

NOTE: There is a reference hole provided at rear end of control rod to help know when holes are vertical.

NOTE: The hole furthest from the chute control head is used to achieve further engagement of the chute control rod into the input shaft if required. Refer to the Maintenance & Adjustments section for Chute Control Rod adjustment.

The hole closest to the chute control head is used for manual movement of the chute assembly if required. Refer to the Controls & Features section.

8. Check that the cables are properly routed through the cable guide on top of the engine. See Figure 9.

NOTE: For smoothest operation, the cables should all be to the left of the chute control rod.

Set-Up

Shear Pins

Holes are located in the plastic dash panel for convenient shear pin storage. See Figure 10. Refer to the Operation section for more information regarding shear pin replacement.

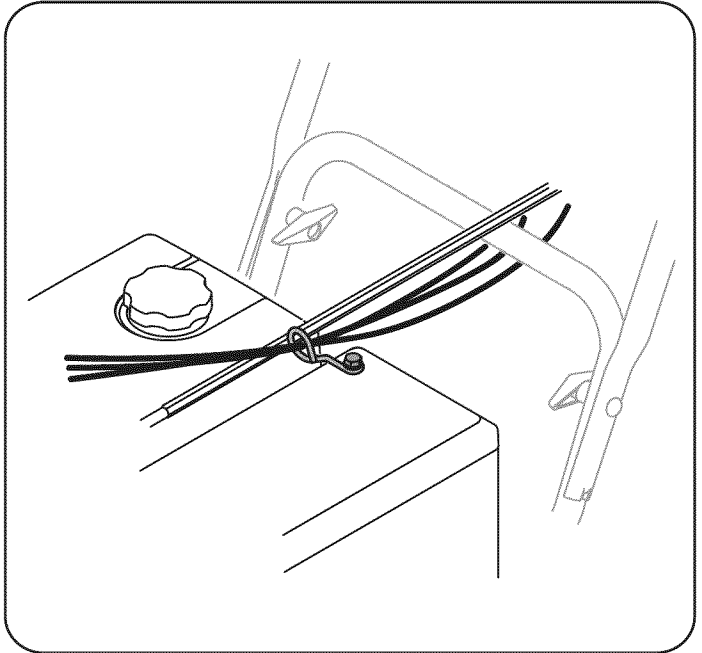

Figure 9

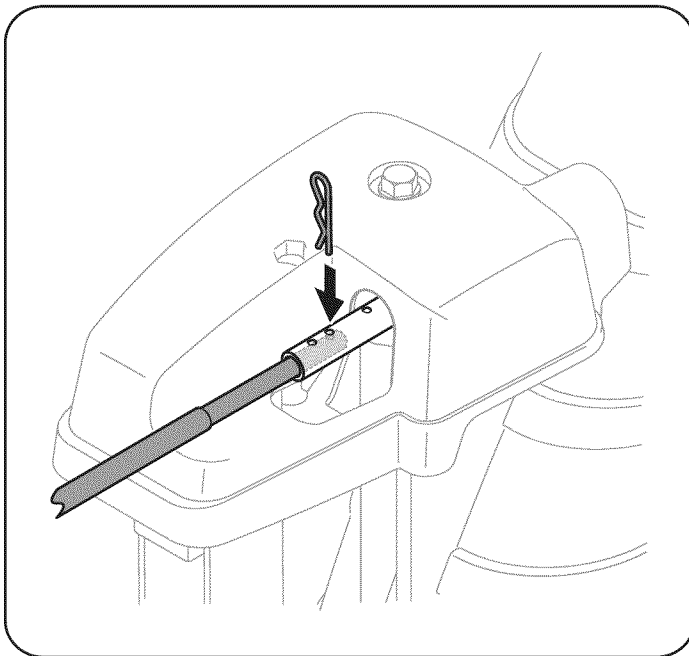

Figure 8

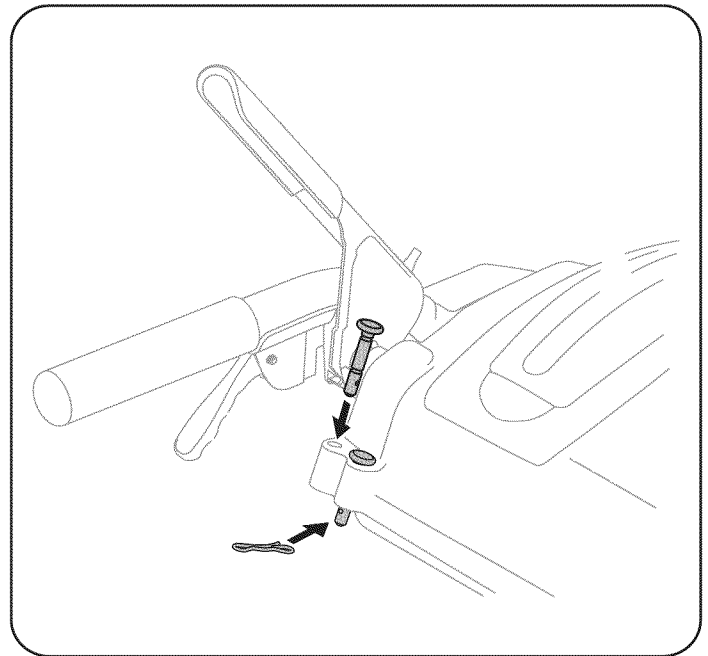

Figure 10

ASSEMBLY

Chute Clean-Out Tool

A chute clean-out tool is fastened to the top of the auger housing with a mounting clip. See Figure 11. The tool is designed to clear a chute assembly of ice and snow. This item is fastened with a cable tie at the factory. Cut the cable tie before operating the snow thrower.

WARNING

Never use your hands to clear a clogged chute assembly. Shut off engine and remain behind handles until all moving parts have stopped before using the clean-out tool to clear the chute assembly.

Drift Cutters

1. Remove the two screws and wing knobs that secure each drift cutter, and remove them from the sides of the auger housing.
2. Turn the drift cutters around and position them as shown in Figure 12 to the outside of the auger housing.
3. Attach the drift cutters with the screws and wing knobs removed earlier. See Figure 13.

Tire Pressure

WARNING

Under any circumstance do not exceed manufacturer's recommended psi. Equal tire pressure should be maintained at all times. Excessive pressure when seating beads may cause tire/rim assembly to burst with force sufficient to cause serious injury. Refer to sidewall of tire for recommended pressure.

The tires are over-inflated for shipping purposes. Check the tire pressure before operating the snow thrower. Refer to the tire side wall for tire manufacturer's recommended psi and deflate (or inflate) the tires as necessary.

NOTE: Equal tire pressure is to be maintained at all times for performance purposes.

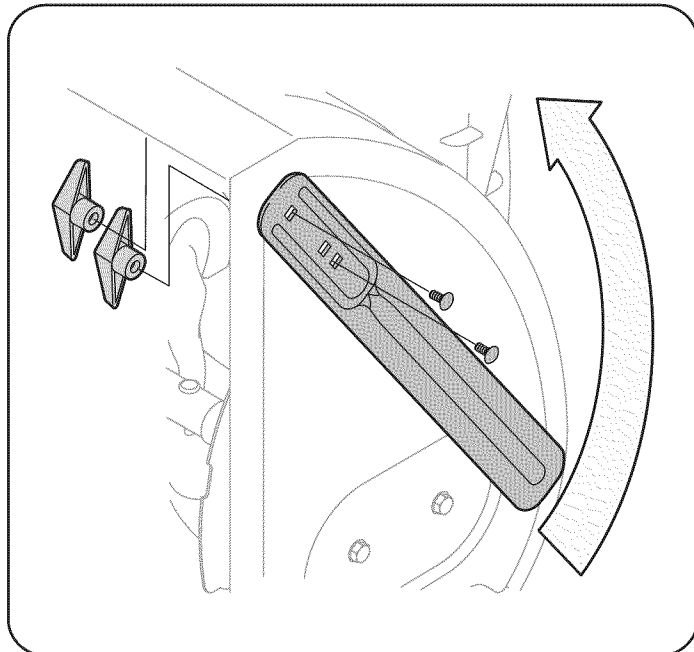

Figure 12

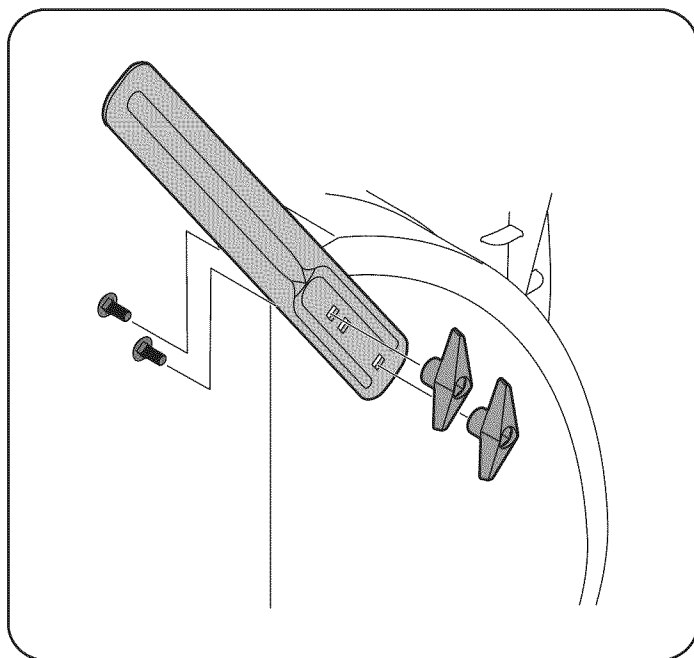

Figure 13

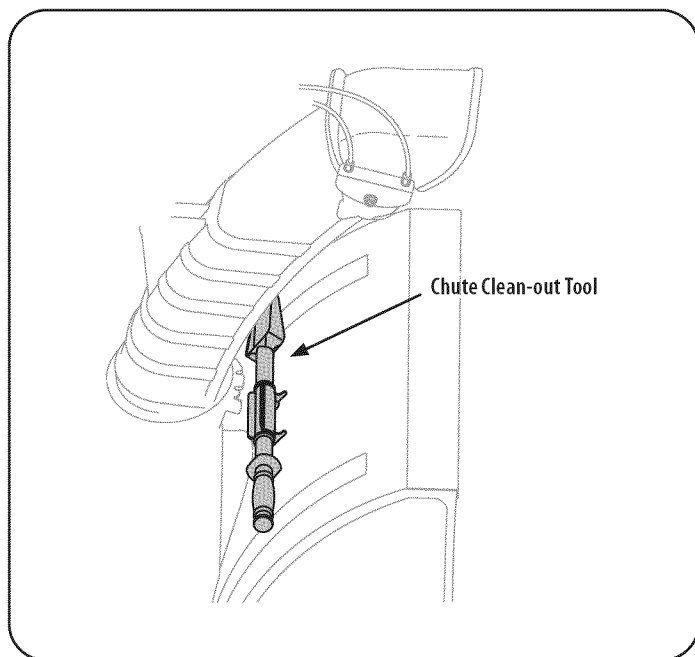

Figure 11

ASSEMBLY

Adjustments

Skid Shoes

The snow thrower skid shoes are adjusted upward at the factory for shipping purposes. Adjust them downward, if desired, prior to operating the snow thrower.

⚠ CAUTION

It is not recommended that you operate this snow thrower on gravel as it can easily pick up and throw loose gravel, causing personal injury or damage to the snow thrower and surrounding property.

- For close snow removal on a smooth surface, raise skid shoes higher on the auger housing. Refer to Figure 14.
- Use a middle or lower position when the area to be cleared is uneven, such as a gravel driveway.

NOTE: If you choose to operate the snow thrower on a gravel surface, keep the skid shoes in position for maximum clearance between the ground and the shave plate.

To adjust the skid shoes:

1. Loosen the four hex nuts (two on each side) and carriage bolts. Move skid shoes to desired position. See Figure 14.
2. Make certain the entire bottom surface of skid shoe is against the ground to avoid uneven wear on the skid shoes.
3. Retighten nuts and bolts securely.

Auger Control

⚠ WARNING

Prior to operating your snow thrower, carefully read and follow all instructions below. Perform all adjustments to verify your snow thrower is operating safely and properly.

Check the adjustment of the auger control as follows:

1. The auger control is located on the left handle. See Figure 15 inset. When the auger control is released and in the disengaged “up” position, the cable should have very little slack. It should NOT be tight.
2. In a well-ventilated area, start the snow thrower engine. Refer to Starting the Engine in the Operation section.
3. While standing in the operator’s position (behind the snow thrower), engage the auger.
4. Allow the auger to remain engaged for approximately ten (10) seconds before releasing the auger control. Repeat this several times.
5. With the auger control in the disengaged “up” position, walk to the front of the machine.
6. Confirm that the auger has completely stopped rotating and shows NO signs of motion. If the auger shows ANY signs of rotating, immediately return to the operator’s position and shut off the engine. Wait for ALL moving parts to stop before adjusting the auger control.

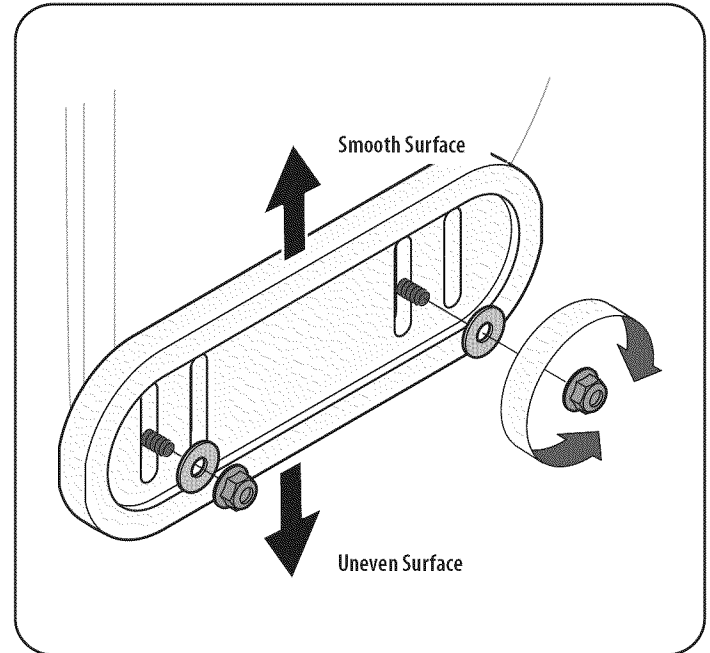

Figure 14

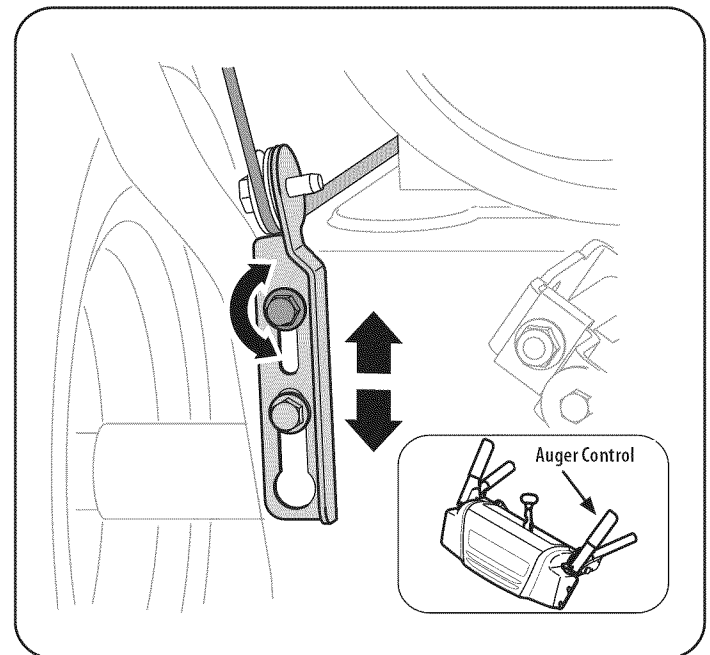

Figure 15

7. To readjust the control cable, loosen the upper hex bolt on the auger cable bracket. See Figure 15.
8. Position the bracket upward to provide more slack (or downward to increase cable tension).
9. Retighten the upper hex bolt.
10. Repeat steps 2-6 above to verify proper adjustment has been achieved.

OPERATION

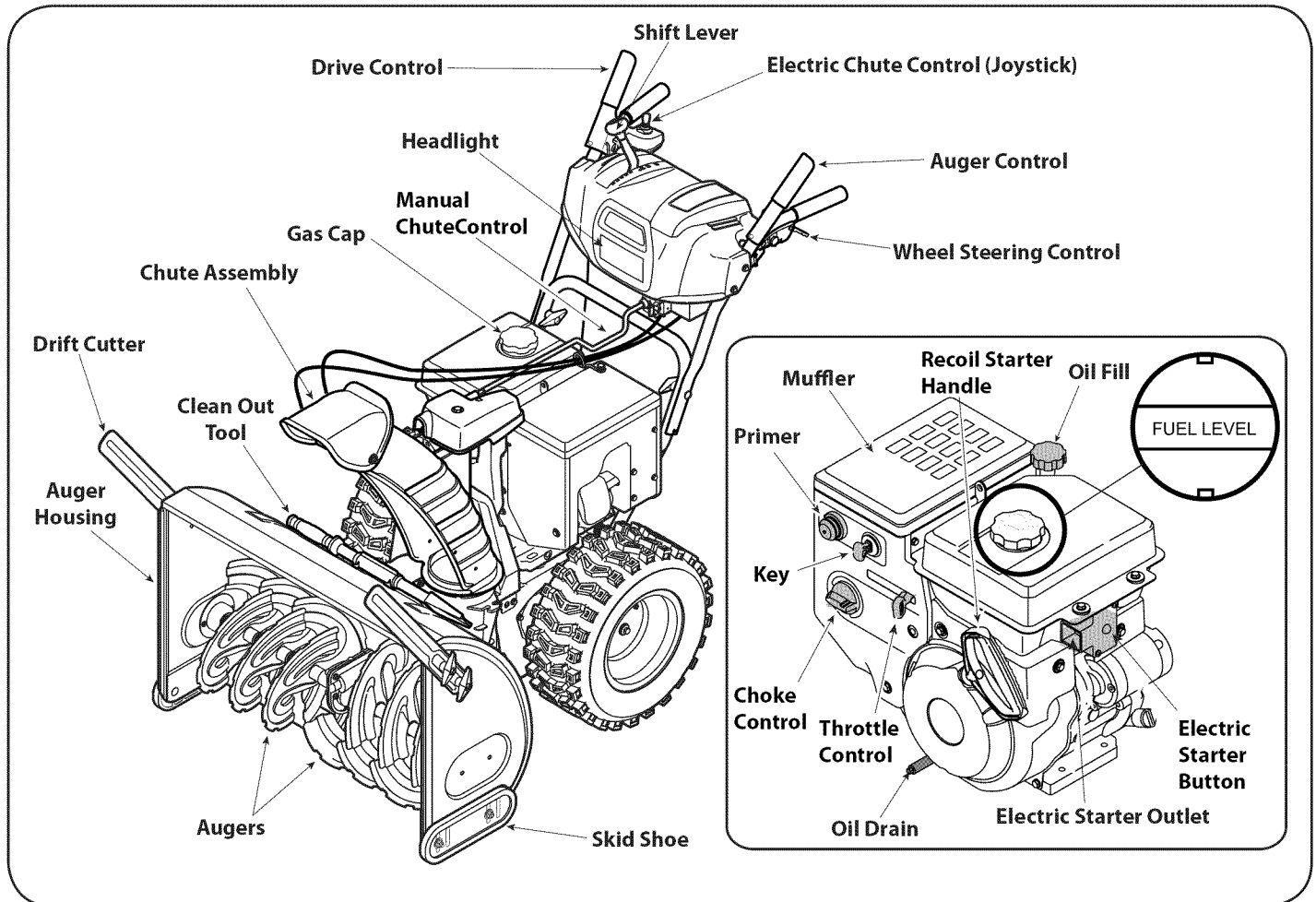

Figure 16

Now that you have set up your snow thrower, it's important to become acquainted with its controls and features. Refer to Figure 16.

Shift Lever

The shift lever is located on the right side of the handle panel. Place the shift lever into any of eight positions to control the direction of travel and ground speed.

Forward

Your snow thrower has six forward (F) speeds. Position one (1) is the slowest and position six (6) is the fastest.

Reverse

Your snow thrower has two reverse (R) speeds. One (1) is the slower and two (2) is the faster.

Drift Cutters

The drift cutters are designed for use in deep snow. Their use is optional for normal snow conditions. Maneuver the snow thrower so that the cutters penetrate a high standing snow drift to assist snow falling into the augers for throwing.

Key

The key is a safety device. It must be fully inserted in order for the engine to start. Remove the key when the snow thrower is not in use.

NOTE: Do not turn the ignition key in an attempt to start the engine. Doing so may cause it to break.

Choke Control

The choke control is found on the rear of the engine and is activated by turning the rotary choke knob to the CHOKE position. Activating the choke control closes the choke plate on the carburetor and aids in starting the engine.

Chute Assembly

Snow drawn into the auger housing is discharged out the chute assembly.

- 6
- 5
- 4
- 3
- 2
- F 1
- R 1
- R 2

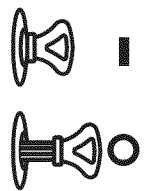

Meets ANSI Safety Standards

Craftsman Snow Throwers conform to the safety standard of the American National Standards Institute (ANSI).

OPERATION

Throttle control



The throttle control is located on the rear of the engine. It regulates the speed of the engine and will shut off the engine when moved into the STOP position.

Primer

Depressing the primer forces fuel directly into the engine's carburetor to aid in cold-weather starting.

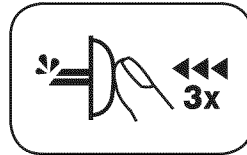

Recoil Starter Handle

This handle is used to manually start the engine.

Electric Starter Button

Pressing the electric starter button engages the engine's electric starter when plugged into a 120V power source.

Electric Starter Outlet

Requires the use of a three-prong outdoor extension cord and a 120V power source/wall outlet.

Oil Fill

Engine oil level can be checked and oil added through the oil fill.

Headlight

The headlight is on whenever the engine is running.

Auger

When engaged, the auger blades rotate and draw snow into the auger housing.

Wheel Steering Controls

The left and right wheel steering controls are located on the underside of the handles. Squeeze the right control to turn right; squeeze the left control to turn left.

NOTE: Operate the snow thrower in open areas until you are familiar with these controls.

Auger Control

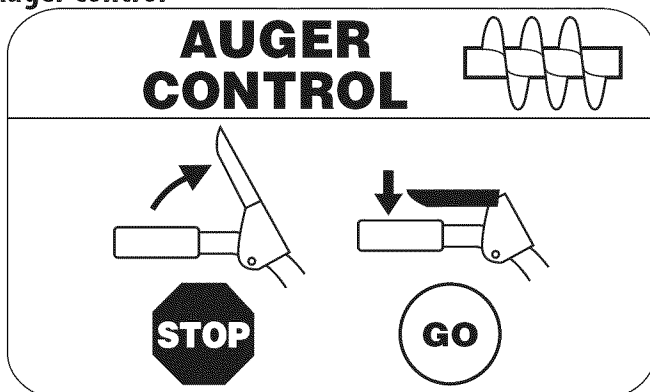

The auger control is located on the left handle. Squeeze the control grip against the handle to engage the auger and start snow throwing action. Release to stop.

Drive Control/ Auger Control Lock

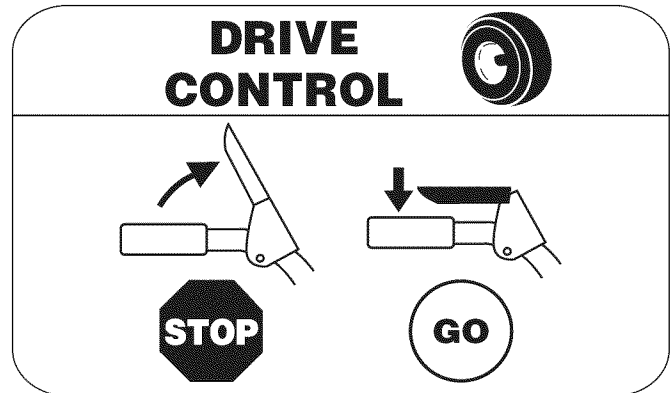

The drive control is located on the right handle. Squeeze the control grip against the handle to engage the wheel drive. Release to stop.

The drive control also locks the auger control so you can operate the chute directional control without interrupting the snow throwing process. If the auger control is engaged simultaneously with the drive control, the operator can release the auger control (on the left handle) and the augers will remain engaged. Release both controls to stop the augers and wheel drive.

NOTE: Always release the drive control before changing speeds. Failure to do so will result in increased wear on your machine's drive system.

Electric Chute Control

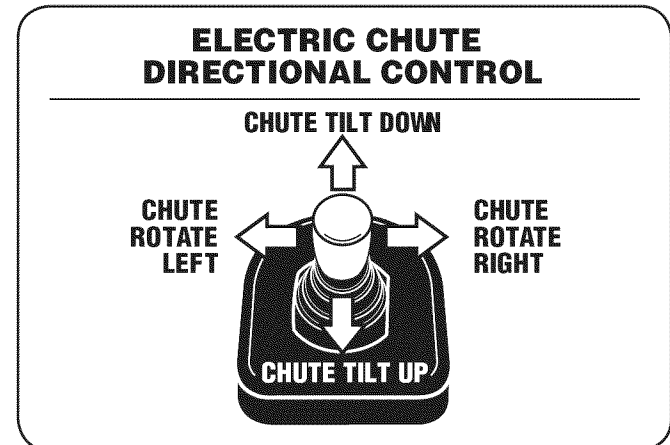

The electric chute control (Joystick) is located on the right side of the handle panel.

- To change the direction in which snow is thrown, move the joystick to the right or to the left.
- To change the angle/distance which snow is thrown, pivot the joystick forward to tilt the chute down and backward to tilt the chute up.

Skid Shoes

Position the skid shoes based on surface conditions. Adjust upward for hard-packed snow. Adjust downward when operating on gravel or crushed rock surfaces.

OPERATION

Manual Chute Control

Proceed as follows to utilize the manual chute control:

1. Remove the cotter pin from either of the holes furthest from the chute assembly on the chute control head.
2. Push in the chute control rod until the hole in it lines up with the third hole in the chute control head. See Figure 17.

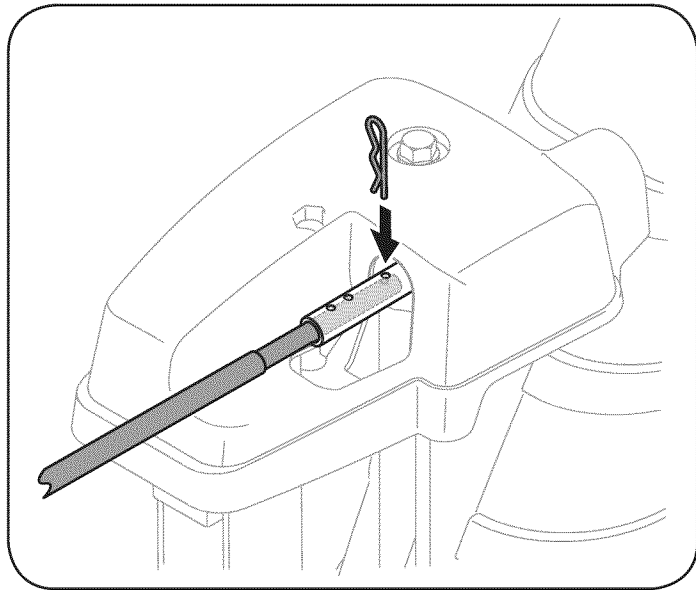

Figure 17

3. Reinsert the cotter pin through this hole and the chute control rod as shown in Figure 17.
4. Grasp the indented portion of the chute control rod and manually rotate the chute to the right or to the left. See Figure 18.

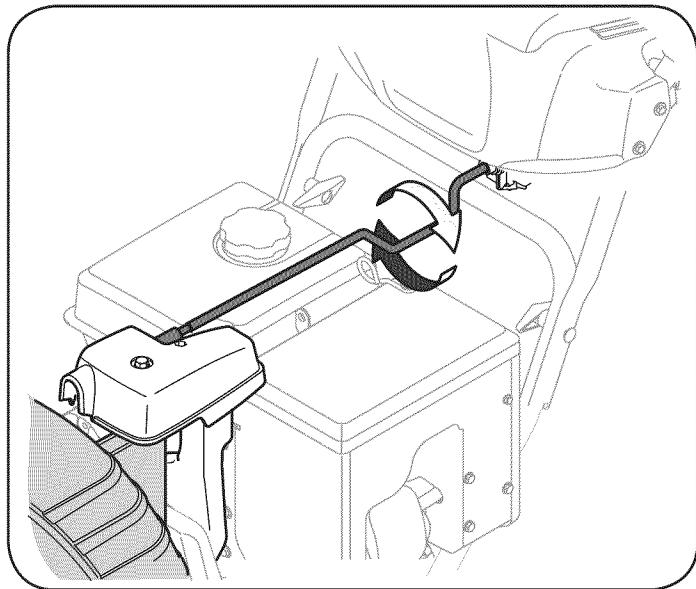

Figure 18

Clean-Out Tool

! WARNING

Never use your hands to clear a clogged chute assembly. Shut off engine and remain behind handles until all moving parts have stopped before using the clean-out tool to clear the chute assembly.

The chute clean-out tool is conveniently fastened to the rear of the auger housing with a mounting clip. Should snow and ice become lodged in the chute assembly during operation, proceed as follows to safely clean the chute assembly and chute opening:

1. Release both the Auger Control and the Drive Control.
2. Stop the engine by removing the ignition key.
3. Remove the clean-out tool from the clip which secures it to the rear of the auger housing.
4. Use the shovel-shaped end of the clean-out tool to dislodge and scoop any snow and ice which has formed in and near the chute assembly.
5. Refasten the clean-out tool to the mounting clip on the rear of the auger housing, reinsert the ignition key and start the snow thrower's engine.
6. While standing in the operator's position (behind the snow thrower), engage the auger control for a few seconds to clear any remaining snow and ice from the chute assembly.

Before Starting Engine

! WARNING

Read, understand, and follow all instructions and warnings on the machine and in this manual before operating.

Oil

The unit was shipped with oil in the engine. Check oil level before each operation to ensure adequate oil in the engine.

NOTE: Be sure to check the engine on a level surface with the engine stopped.

1. Remove the oil filler cap/dipstick and wipe the dipstick clean.
2. Insert the cap/dipstick into the oil filler neck, but do NOT screw it in.
3. Remove the oil filler cap/dipstick. If the level is low, slowly add oil (5W-30, with a minimum classification of SF/SG) until oil level registers between high (H) and low (L).

NOTE: Do not overfill. Overfilling with oil may result in engine smoking, hard starting or spark plug fouling.

4. Replace and tighten cap/dipstick firmly before starting engine.

OPERATION

Gasoline

Use automotive gasoline (unleaded or low leaded to minimize combustion chamber deposits) with a minimum of 87 octane. Gasoline with up to 10% ethanol or 15% MTBE (Methyl Tertiary Butyl Ether) can be used. Never use an oil/gasoline mixture or dirty gasoline. Avoid getting dirt, dust, or water in the fuel tank. DO NOT use E85 gasoline.

- Refuel in a well-ventilated area with the engine stopped. Do not smoke or allow flames or sparks in the area where the engine is refueled or where gasoline is stored.
- Do not overfill the fuel tank. After refueling, make sure the tank cap is closed properly and securely.
- Be careful not to spill fuel when refueling. Spilled fuel or fuel vapor may ignite. If any fuel is spilled, make sure the area is dry before starting the engine.
- Avoid repeated or prolonged contact with skin or breathing of vapor.

WARNING

Use extreme care when handling gasoline. Gasoline is extremely flammable and the vapors are explosive. Never fuel the machine indoors or while the engine is hot or running. Extinguish cigarettes, cigars, pipes and other sources of ignition.

1. Clean around fuel fill before removing cap to fuel.
2. A fuel level indicator is located in the fuel tank. See Figure 16 inset. Be careful not to overfill. Fill tank until fuel reaches the fuel level indicator to allow space for fuel expansion.

Starting The Engine

WARNING

Always keep hands and feet clear of moving parts. Do not use a pressurized starting fluid. Vapors are flammable.

NOTE: Allow the engine to warm up for a few minutes after starting. The engine will not develop full power until it reaches operating temperatures.

1. Make certain both the auger control and drive control are in the disengaged (released) position.
2. Insert key into slot. Make sure it snaps into place. Do not attempt to turn the key.

NOTE: The engine cannot start without the key fully inserted into the ignition switch.

Electric Starter

WARNING

The electric starter is equipped with a grounded three-wire power plug, and is designed to operate on 120 volt AC household current. It must be used with a properly grounded three-prong receptacle at all times to avoid the possibility of electric shock. Follow all instructions carefully prior to operating the electric starter. DO NOT use electric starter in the rain.



Determine that your home's wiring is a three-wire grounded system. Ask a licensed electrician if you are not certain.

If you have a grounded three-prong receptacle, proceed as follows. If you do not have the proper house wiring, DO NOT use the electric starter under any conditions.

1. Plug an extension cord into the outlet located on the engine's surface. Plug the other end of extension cord into a three-prong 120-volt, grounded, AC outlet in a well-ventilated area.

CAUTION

The extension cord can be any length, but **must** be rated for 15 amps at 125 volts, grounded and rated for outdoor use.



2. Move throttle control to FAST (rabbit ) position.
3. Move choke to the CHOKE  position (cold engine start). If engine is warm, place choke in RUN position.
4. Push primer three (3) times, making sure to cover vent hole in primer bulb when pushing. If engine is warm, push primer only once. Always cover vent hole when pushing. Cool weather may require priming to be repeated.
5. Push starter button to start engine. Once the engine starts, immediately release starter button. Electric starter is equipped with thermal overload protection; system will temporarily shut-down to allow starter to cool if electric starter becomes overloaded.
6. As the engine warms, slowly rotate the choke control to RUN position. If the engine falters, restart engine and run with choke at half-choke position for a short period of time, and then slowly rotate the choke into RUN position.
7. After engine is running, disconnect power cord from electric starter. When disconnecting, always unplug the end at the wall outlet before unplugging the opposite end from the engine.

OPERATION

Recoil Starter

CAUTION

Do not pull the starter handle while the engine running.

1. Move throttle control to FAST (rabbit)  position.
2. Move choke to the CHOKE  position (cold engine start). If engine is warm, place choke in RUN position.
3. Push primer three (3) times, making sure to cover vent hole when pushing. If engine is warm, push primer only once. Always cover vent hole when pushing. Cool weather may require priming to be repeated.
4. Pull gently on the starter handle until it begins to resist, then pull quickly and forcefully to overcome the compression. Do not release the handle and allow it to snap back. Return rope SLOWLY to original position. If required, repeat this step.
5. As the engine warms, slowly rotate the choke control to RUN position. If the engine falters, restart engine and run with choke at half-choke position for a short period of time, and then slowly rotate the choke into RUN position.

WARNING

To avoid unsupervised engine operation, never leave the machine unattended with the engine running. Turn the engine off after use and remove key.

Stopping The Engine

After you have finished snow-throwing, run engine for a few minutes before stopping to help dry off any moisture on the engine.

1. Move throttle control to OFF position.
2. Remove the key. Removing the key will reduce the possibility of unauthorized starting of the engine while equipment is not in use. Keep the key in a safe place. The engine cannot start without the key.
3. Wipe any moisture away from the controls on the engine.

To Engage Drive

1. With the throttle control in the Fast (rabbit)  position, move shift lever into one of the six forward (F) positions or two reverse (R) positions. Select a speed appropriate for the snow conditions and a pace you're comfortable with.

NOTE: When selecting a Drive Speed, use the slower speeds until you are comfortable and familiar with the operation of the snow thrower.

2. Squeeze the drive control against the handle and the snow thrower will move. Release it and drive motion will stop.

NOTE: NEVER reposition the shift lever (change speeds or direction of travel) without first releasing the drive control and bringing the snow thrower to a complete stop. Doing so will result in premature wear to the snow thrower's drive system.

To Engage Auger

1. To engage the auger and start throwing snow, squeeze the auger control against the left handle. Release to stop the auger.

Replacing Shear Pins

Each auger blade is secured to the spiral shaft with a shear pin and bow-tie clip. If an auger blade strikes a foreign object or ice jam, the pin will shear off to prevent damage to the blade. If an auger blade does not turn, check to see if its pin has sheared off. See Figure 19.

CAUTION

NEVER replace the auger shear pins with anything other than Sears SKU# 88389/OEM Part No. 738-04124A replacement shear pins. Any damage to the auger gearbox or other components as a result of failing to do so will NOT be covered by your snow thrower's warranty.

WARNING

Always turn off the snow thrower's engine and remove the key prior to replacing shear pins.

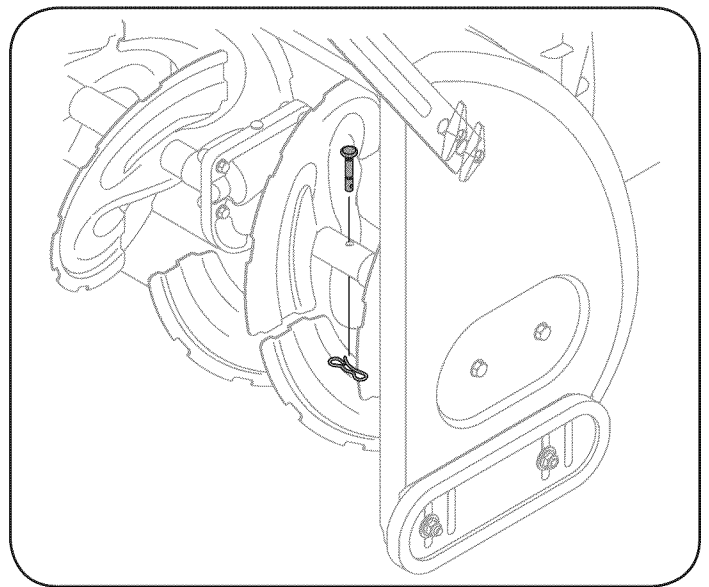

Figure 19

SERVICE AND MAINTENANCE

MAINTENANCE SCHEDULE

⚠ WARNING

Before performing any type of maintenance/service, disengage all controls and stop the engine. Wait until all moving parts have come to a complete stop. Disconnect spark plug wire and ground it against the engine to prevent unintended starting.

Follow the maintenance schedule given below. This chart describes service guidelines only. Use the Service Log column to keep track of completed maintenance tasks. To locate the nearest Sears Service Center or to schedule service, simply contact Sears at 1-800-4-MY-HOME®.

Interval	Item	Service	Service Log
Each Use and every 5 hours	1. Engine oil level 2. Loose or missing hardware 3. Unit and engine.	1. Check 2. Tighten or replace 3. Clean	
1st 5 hours	1. Engine oil	1. Change	
Annually or 25 hours	1. Spark plug 2. Control linkages and pivots 3. Wheels 4. Gear shaft and Auger shaft	1. Check 2. Lube with light oil 3. Lube with multipurpose auto grease 4. Lube with light oil	
Annually or 50 hours	1. Engine oil	1. Change	
Annually or 100 hours	1. Spark plug	1. Change	
Before Storage	1. Fuel system	1. Run engine until it stops from lack of fuel	

GENERAL RECOMMENDATIONS

Checking Engine Oil

⚠ WARNING

Before lubricating, repairing, or inspecting, disengage all controls and stop engine. Wait until all moving parts have come to a complete stop.

NOTE: Check the oil level before each use to be sure correct oil level is maintained.

When adding oil to the engine, refer to viscosity chart below. Engine oil capacity is 1100 ml (approx. 37 oz.). Do not over-fill. Use a 4-stroke, or an equivalent high detergent, premium quality motor oil certified to meet or exceed U.S. automobile manufacturer's requirements for service classification SG, SF. Motor oils classified SG, SF will show this designation on the container.

1. Remove the oil filler cap/dipstick and wipe the dipstick clean.
2. Insert the cap/dipstick into the oil filler neck, but do NOT screw it in.
3. Remove the oil filler cap/dipstick. If level is low, slowly add oil until oil level registers between high (H) and low (L). See Figure 20.
4. Replace and tighten cap/dipstick firmly before starting engine.

Changing Engine Oil

NOTE: Change the engine oil after the first 5 hours of operation and once a season or every 50 hours thereafter.

1. Drain fuel from tank by running engine until the fuel tank is empty. Be sure fuel fill cap is secure.
2. Place suitable oil collection container under oil drain plug.
3. Remove oil drain plug. See Figure 21 on next page.

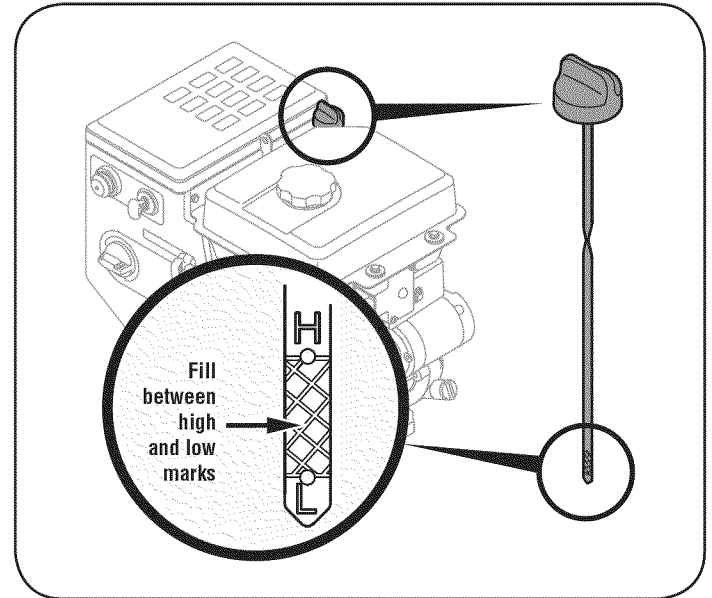

Figure 20

4. Tip unit to drain oil into the container. Used oil must be disposed of at a proper collection center.

⚠ CAUTION

Used oil is a hazardous waste product. Dispose of used oil properly. Do not discard with household waste. Check with your local authorities or Sears Service Center for safe disposal/recycling facilities.

5. Reinstall the drain plug and tighten it securely.

SERVICE AND MAINTENANCE

6. Refill with the recommended oil and check the oil level. See Recommended Oil Usage chart. The engine's oil capacity is 37 ounces.

	Synthetic 0W-30				
	5W-30				
(°F)	-40°	-20°	0°	20°	40°
(°C)	-30°	-20°	-10°	0°	

⚠ CAUTION

DO NOT use nondetergent oil or 2-stroke engine oil. It could shorten the engine's service life.

7. Reinstall the oil filler cap/dipstick securely.

⚠ CAUTION

Thoroughly wash your hands with soap and water as soon as possible after handling used oil.

Checking Spark Plug

⚠ WARNING

DO NOT check for spark with spark plug removed. DO NOT crank engine with spark plug removed.

⚠ WARNING

If the engine has been running, the muffler will be very hot. Be careful not to touch the muffler.

NOTE: Check the spark plug once a season or every 25 hours of operation. Change the spark plug once a season or every 100 hours. To ensure proper engine operation, the spark plug must be properly gapped and free of deposits.

1. Remove the spark plug boot and use a spark plug wrench to remove the plug. See Figure 22.
2. Visually inspect the spark plug. Discard the spark plug if there is apparent wear, or if the insulator is cracked or chipped. Clean the spark plug with a wire brush if it is to be reused.
3. Measure the plug gap with a feeler gauge. Correct as necessary by bending side electrode. See Figure 23. The gap should be set to .02-.03 inches (0.60-0.80 mm).
4. Check that the spark plug washer is in good condition and thread the spark plug in by hand to prevent cross-threading.
5. After the spark plug is seated, tighten with a spark plug wrench to compress the washer.

NOTE: When installing a new spark plug, tighten 1/2-turn after the spark plug seats to compress the washer. When reinstalling a used spark plug, tighten 1/8- to 1/4-turn after the spark plug seats to compress the washer.

⚠ CAUTION

The spark plug must be tightened securely. A loose spark plug can become very hot and can damage the engine.

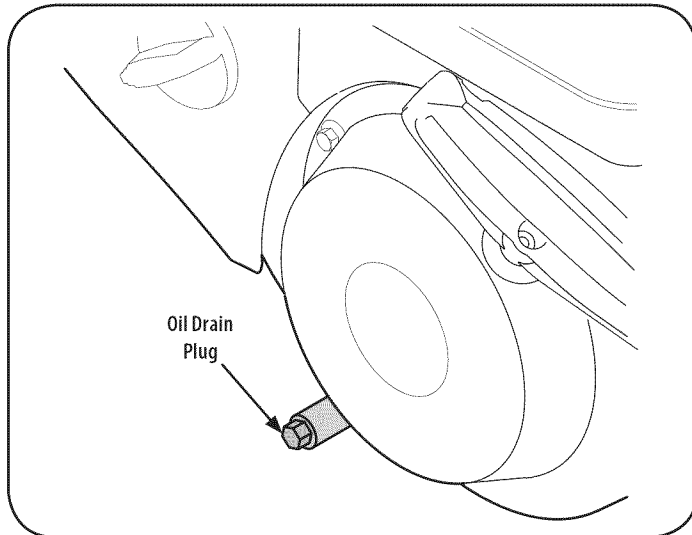

Figure 21

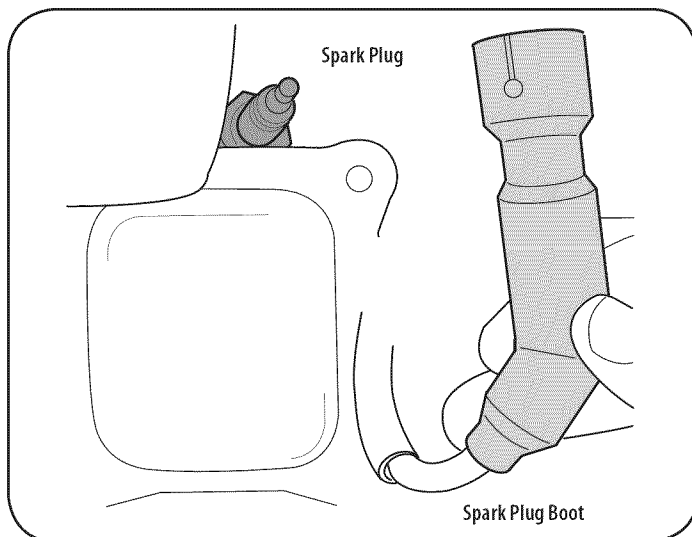

Figure 22

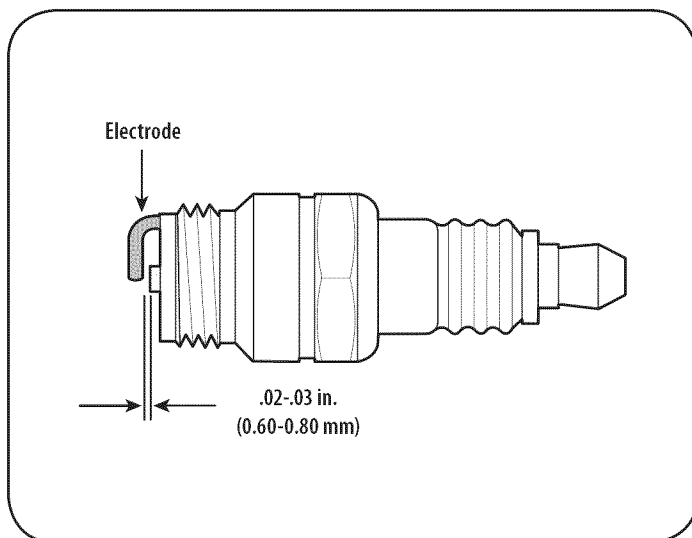

Figure 23

SERVICE AND MAINTENANCE

Lubrication

Gear Shaft

The gear (hex) shaft should be lubricated at least once a season or after every 25 hours of operation.

1. To prevent spillage, remove all fuel from tank by running engine until it stops.
2. Carefully pivot the snow thrower up and forward so that it rests on the auger housing.
3. Remove the lower frame cover from the underside of the snow thrower by removing the self-tapping screws which secure it.
4. Apply a light coating of engine oil (or 3-in-1 oil) to the hex shaft. See Figure 24.

NOTE: When lubricating the hex shaft, be careful not to get any oil on the aluminum drive plate or rubber friction wheel. Doing so will hinder the snow thrower's drive system. Wipe off any excess or spilled oil.

Wheels

At least once a season, remove both wheels. Clean and coat the axles with a multipurpose automotive grease before reinstalling wheels.

Auger Shaft

At least once a season, remove the shear pins on auger shaft. Spray lubricant inside shaft, and around the spacers and flange bearings found at either end of the shaft. See Figure 25.

Shave Plate and Skid Shoes

The shave plate and skid shoes on the bottom of the snow thrower are subject to wear. They should be checked periodically and replaced when necessary.

NOTE: The skid shoes on this machine have two wear edges. When one side wears out, they can be rotated 180° to use the other edge.

To remove skid shoes:

1. Remove the two carriage bolts, washers, and hex flange nuts that secure each skid shoe to the snow thrower.
2. Reassemble new skid shoes with the four carriage bolts (two on each side), washers, and hex flange nuts. Refer to Figure 26.

To remove shave plate:

1. Remove the carriage bolts and hex nuts which attach it to the snow thrower housing.
2. Reassemble new shave plate, making sure heads of carriage bolts are to the inside of housing. Tighten securely. See Figure 26.

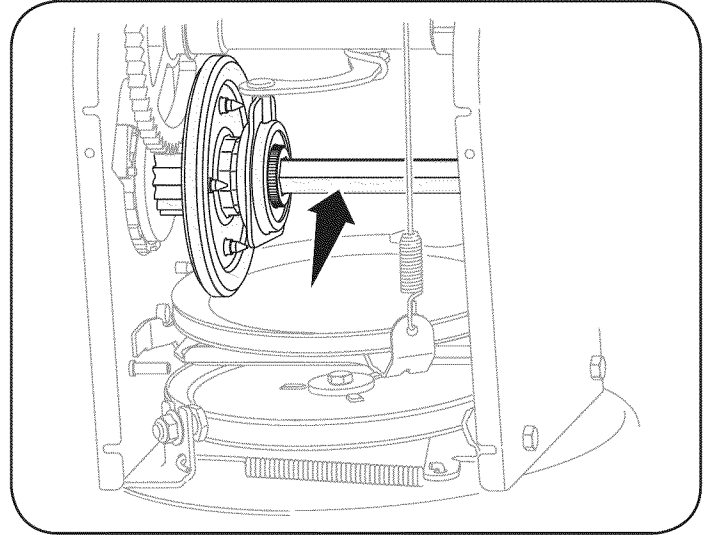

Figure 24

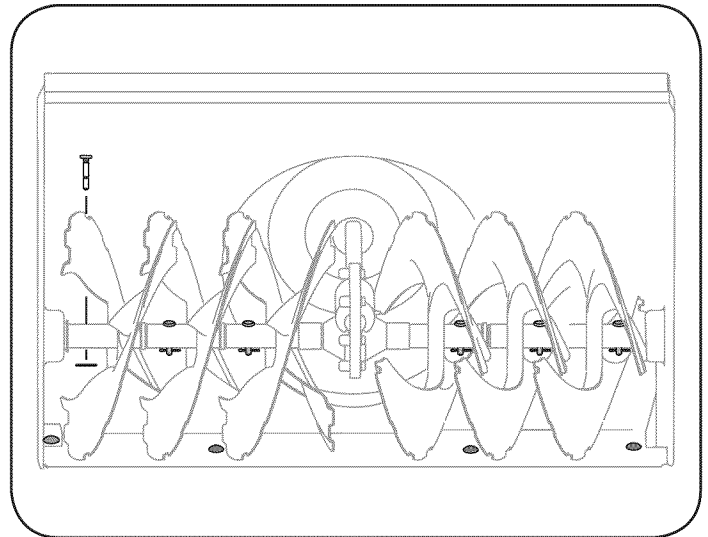

Figure 25

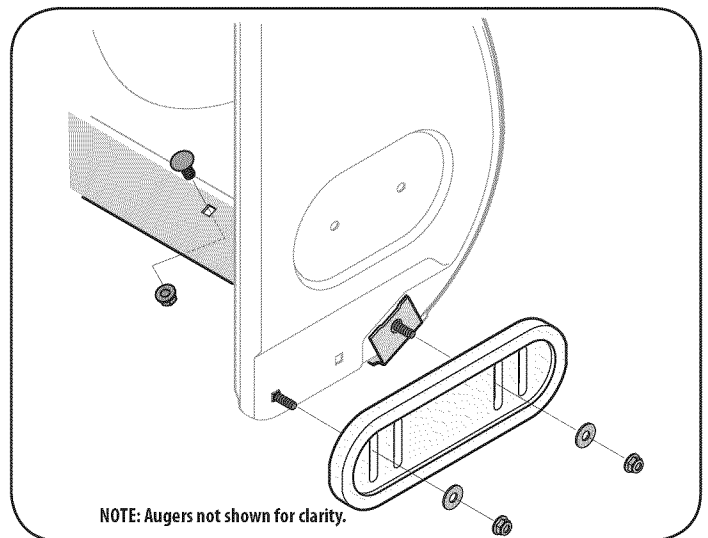

Figure 26

SERVICE AND MAINTENANCE

Adjustments

Shift Cable

If the full range of speeds (forward and reverse) cannot be achieved, refer to the figure to the right and adjust the shift cable as follows:

1. Place the shift lever in the fastest forward speed position (F6).
2. Loosen the hex nut on the shift cable index bracket. See Figure 27.
3. Pivot the bracket downward to take up slack in the cable.
4. Retighten the hex nut.

Drive Control

When the drive control is released and in the disengaged “up” position, the cable should have very little slack. It should NOT be tight. Also, if there is excessive slack in the drive cable or if the unit experiences intermittent drive while using, the cable may need to be adjusted. Check the adjustment of the drive control as follows:

1. With the drive control released, push the snow thrower gently forward. The unit should roll freely.
2. Engage the drive control and gently attempt to push the snow thrower forward. The wheels should not turn. The unit should not roll freely.
3. With the drive control released, move the shift lever back and forth between the R2 position and the F6 position several times. There should be no resistance in the shift lever.
4. If any of the above tests failed, the drive cable is in need of adjustment. Proceed as follows:
 - a. Shut off the engine as instructed in the Operation section.
 - b. Loosen the lower hex bolt on the drive cable bracket. See Figure 28.
 - c. Position the bracket upward to provide more slack (or downward to increase cable tension).
 - d. Retighten the lower hex bolt.

Chute Control Rod

To achieve more chute control rod engagement in the input shaft under the handle panel, the chute control rod will have to be adjusted. Refer to Figure 29.

To adjust this rod, proceed as follows:

1. Remove the cotter pin from the hole closest to the chute control head on the chute control input.
2. Pull out the chute control rod until the hole in it lines up with the other hole in the chute control input.
3. Reinsert the cotter pin through this hole and the chute control rod.

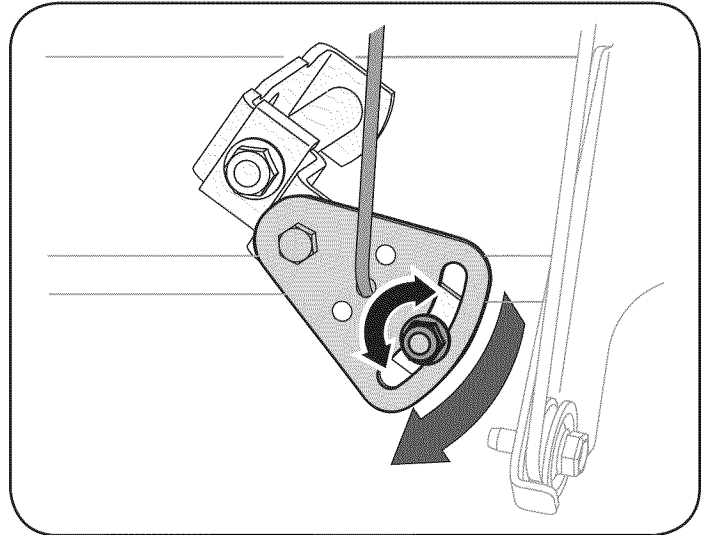

Figure 27

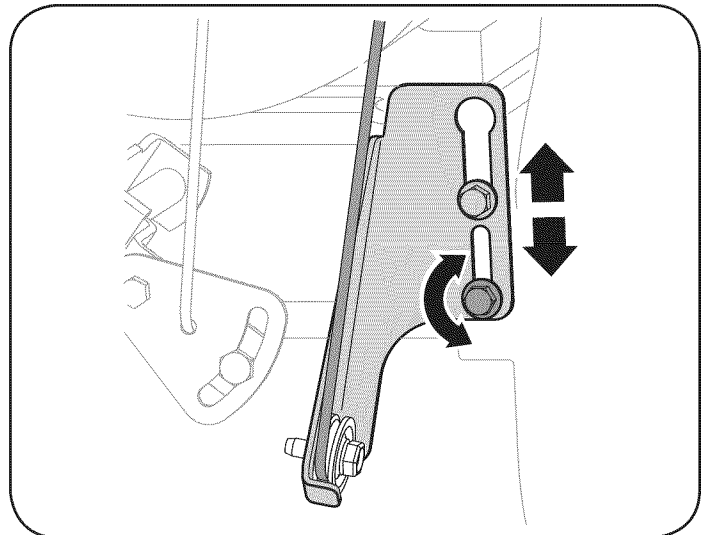

Figure 28

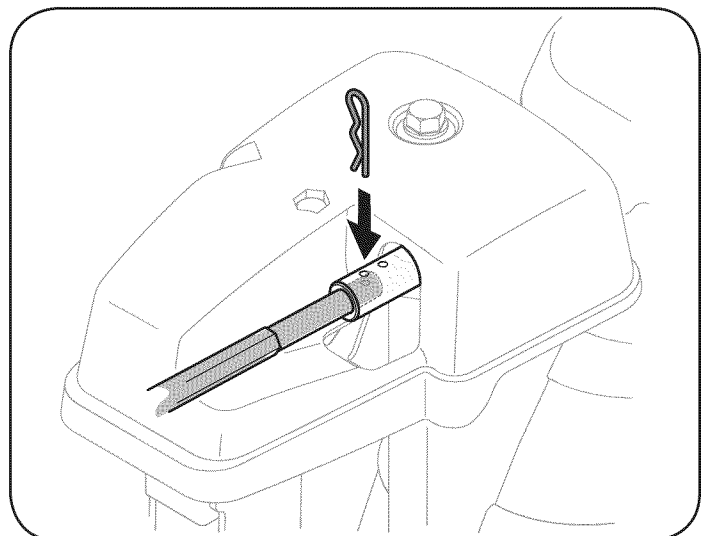

Figure 29

SERVICE AND MAINTENANCE

Auger Control

Refer to the Assembly section for instructions on adjusting the auger control cable.

Skid Shoes

Refer to the Assembly section for instructions on adjusting the skid shoes.

Belt Replacement

Auger Belt

To remove and replace your snow thrower's auger belt, proceed as follows:

1. To prevent spillage, remove all fuel from tank by running engine until it stops.
2. Remove the plastic belt cover on the front of the engine by removing the two self-tapping screws. See Figure 30.
3. Roll the auger belt off the engine pulley. See Figure 31.
4. Carefully pivot the snow thrower up and forward so that it rests on the auger housing.
5. Remove the frame cover from the underside of the snow thrower by removing four self-tapping screws which secure it. See Figure 32.

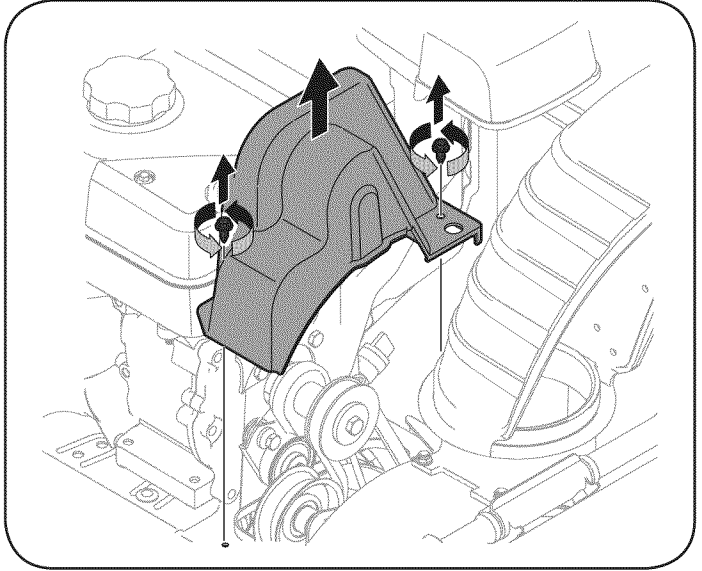

Figure 30

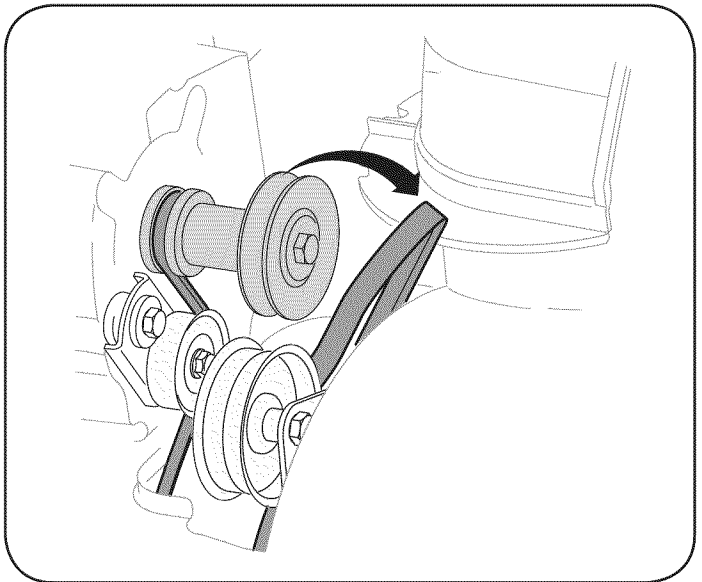

Figure 31

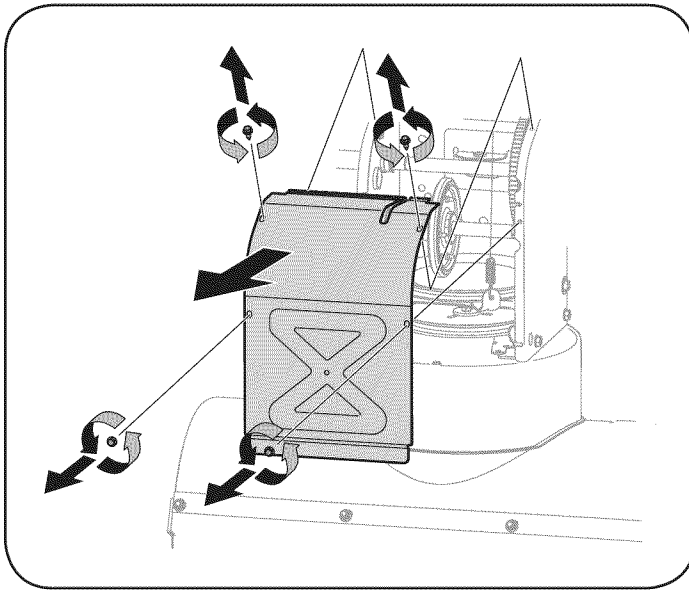

Figure 32

SERVICE AND MAINTENANCE

- Loosen and remove the shoulder screw which acts as a belt keeper. Refer to Figure 33.
- Remove the belt from around the auger pulley, and slip the belt between the support bracket and the auger pulley. See Figure 34.
NOTE: Engaging the auger control will ease removal and reinstallation of the belt.
- Reassemble auger belt by following instructions in reverse order.
NOTE: Do NOT forget to reinstall the shoulder screw and reconnect the spring to the frame after installing a replacement auger belt.
- Perform the Auger Control test outlined in the Assembly section of this manual.

Drive Belt

NOTE: Several components must be removed and special tools are required in order to replace the snow thrower's drive belt. Contact the nearest Sears Parts & Repair Center to have the drive belt replaced.

Friction Wheel Inspection

If the snow thrower fails to drive with the drive control engaged, and performing the Drive Control Cable Adjustment fails to correct the problem, the friction wheel may need to be replaced. Examine the friction wheel rubber for signs of wear or cracking and replace wheel if necessary.

NOTE: Several components must be removed and special tools are required in order to replace this snow thrower's friction wheel. If your friction wheel needs to be replaced, contact the nearest Sears Parts & Repair Center.

To inspect the friction wheel, proceed as follows:

- Allow the engine to run until it is out of fuel. Do not attempt to pour fuel from the engine.
- Carefully pivot the snow thrower up and forward so that it rests on the auger housing.
- Remove the frame cover from the underside of the snow thrower by removing four self-tapping screws which secure it. Refer to Figure 32.
- Examine the friction wheel for signs of wear or cracking.

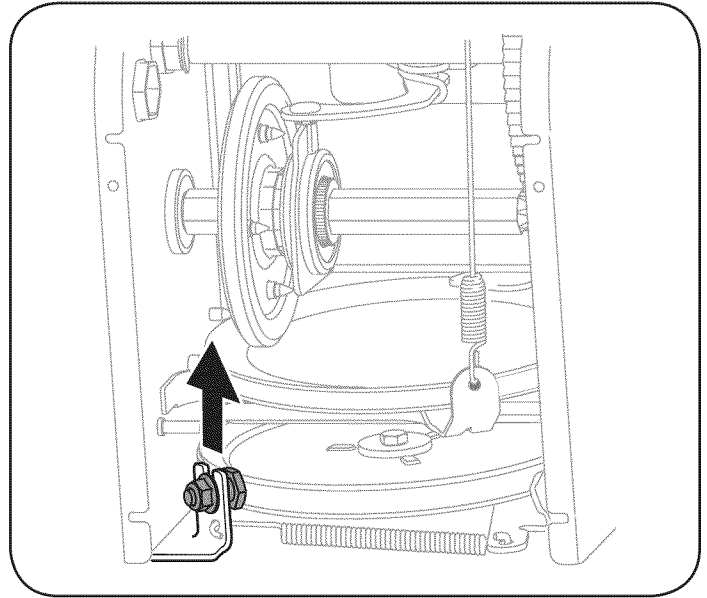

Figure 33

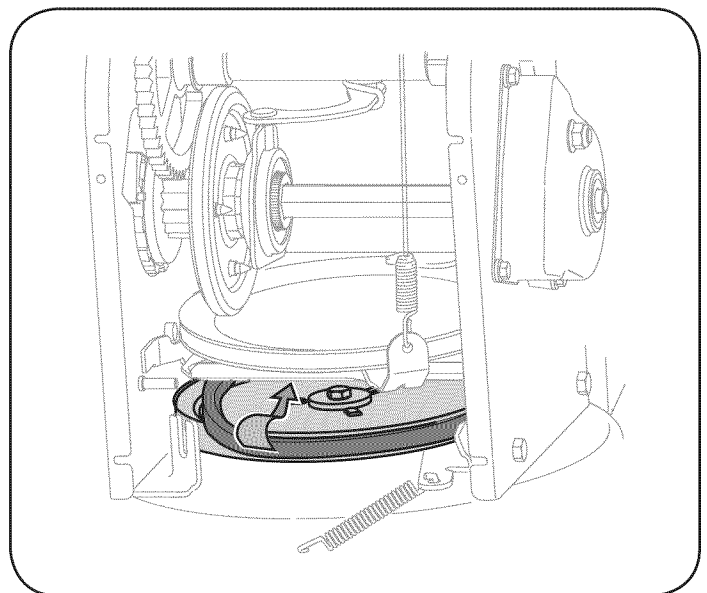

Figure 34

OFF-SEASON STORAGE

If the snow thrower will not be used for 30 days or longer, or if it is the end of the snow season when the last possibility of snow is gone, the equipment needs to be stored properly. Follow storage instructions below to ensure top performance from the snow thrower for many more years.

Preparing Engine

Engines stored over 30 days need to be drained of fuel to prevent deterioration and gum from forming in fuel system or on essential carburetor parts. If the gasoline in your engine deteriorates during storage, you may need to have the carburetor, and other fuel system components, serviced or replaced.

1. Remove all fuel from tank by running engine until it stops. Do not attempt to pour fuel from the engine.
 2. Change the engine oil.
 3. Remove spark plug and pour approximately 1 oz. (30 ml) of clean engine oil into the cylinder. Pull the recoil starter several times to distribute the oil, and reinstall the spark plug.
 4. Clean debris from around engine, and under, around, and behind muffler. Apply a light film of oil on any areas that are susceptible to rust.
- Store in a clean, dry and well ventilated area away from any appliance that operates with a flame or pilot light, such as a furnace, water heater, or clothes dryer. Avoid any area with a spark producing electric motor, or where power tools are operated.

WARNING

Never store snow thrower with fuel in tank indoors or in poorly ventilated areas, where fuel fumes may reach an open flame, spark or pilot light as on a furnace, water heater, clothes dryer or gas appliance.

- If possible, avoid storage areas with high humidity.
- Keep the engine level in storage. Tilting can cause fuel or oil leakage.

Preparing Snow Thrower

- When storing the snow thrower in an unventilated or metal storage shed, care should be taken to rustproof the equipment. Using a light oil or silicone, coat the equipment, especially any chains, springs, bearings and cables.
- Remove all dirt from exterior of engine and equipment.
- Follow lubrication recommendations.
- Store equipment in a clean, dry area.
- Inflate the tires to the maximum PSI. Refer to tire sidewall.

NOTES

TROUBLESHOOTING

WARNING

Disconnect the spark plug wire and ground it against the engine to prevent unintended starting. Before performing any type of maintenance/service, disengage all controls and stop the engine. Wait until all moving parts have come to a complete stop. Always wear safety glasses during operation or while performing any adjustments or repairs.

This section addresses minor service issues. To locate the nearest Sears Service Center or to schedule service, simply contact Sears at 1-800-4-MY-HOME®.

Problem	Cause	Remedy
Engine fails to start	<ol style="list-style-type: none"> 1. Choke control not in CHOKE position. 2. Spark plug wire disconnected. 3. Faulty spark plug. 4. Fuel tank empty or stale fuel. 5. Engine not primed. 6. Key not inserted. 7. Extension cord not connected (when using electric start button, on models so equipped). 	<ol style="list-style-type: none"> 1. Move choke control to CHOKE position. 2. Connect wire to spark plug. 3. Clean, adjust gap, or replace. 4. Fill tank with clean, fresh gasoline. 5. Prime engine as instructed in the Operation Section. 6. Insert key fully into the switch. 7. Connect one end of the extension cord to the electric starter outlet and the other end to a three-prong 120-volt, grounded, AC outlet.
Engine running erratically/inconsistent RPM (hunting or surging)	<ol style="list-style-type: none"> 1. Engine running on CHOKE. 2. Stale fuel. 3. Water or dirt in fuel system. 4. Carburetor out of adjustment. 5. Over-governed engine. 	<ol style="list-style-type: none"> 1. Move choke control to RUN position. 2. Fill tank with clean, fresh gasoline. 3. Drain fuel tank by running engine until it stops. Refill with fresh fuel. 4. Contact your Sears Parts & Repair Center. 5. Contact your Sears Parts & Repair Center.
Excessive vibration	<ol style="list-style-type: none"> 1. Loose parts or damaged auger. 	<ol style="list-style-type: none"> 1. Stop engine immediately and disconnect spark plug wire. Tighten all bolts and nuts. If vibration continues, have unit serviced by a Sears Parts & Repair Center.
Loss of power	<ol style="list-style-type: none"> 1. Spark plug wire loose. 2. Gas cap vent hole plugged. 	<ol style="list-style-type: none"> 1. Connect and tighten spark plug wire. 2. Remove ice and snow from gas cap. Be certain vent hole is clear.
Unit fails to propel itself	<ol style="list-style-type: none"> 1. Drive cable in need of adjustment. 2. Drive belt loose or damaged. 3. Worn friction wheel. 	<ol style="list-style-type: none"> 1. Adjust drive control cable. Refer to Service and Maintenance section. 2. Have drive belt replaced. Contact your Sears Parts & Repair Center. 3. Have friction wheel replaced at a Sears Parts & Repair Center.

NEED MORE HELP?

You'll find the answer and more on managemylife.com – for free!

- Find this and all your other product manuals online.
- Get answers from our team of home experts.
- Get a personalized maintenance plan for your home.
- Find information and tools to help with home projects.



brought to you by Sears

TROUBLESHOOTING

Problem	Cause	Remedy
Unit fails to discharge snow	<ol style="list-style-type: none"> 1. Chute assembly clogged. 2. Foreign object lodged in auger. 3. Auger cable in need of adjustment. 4. Auger belt loose or damaged. 5. Shear pin(s) sheared. 	<ol style="list-style-type: none"> 1. Stop engine immediately and disconnect spark plug wire. Clean chute assembly and inside of auger housing with clean-out tool or a stick. 2. Stop engine immediately and disconnect spark plug wire. Remove object from auger with clean-out tool or a stick. 3. Adjust auger control cable. Refer to Assembly section. 4. Replace auger belt. Refer to Service and Maintenance section. 5. Replace with new shear pin(s).
Chute fails to easily rotate 180 degrees	<ol style="list-style-type: none"> 1. Chute assembled incorrectly. 	<ol style="list-style-type: none"> 1. Disassemble chute control and reassemble as directed in the Assembly section.

NEED MORE HELP?

You'll find the answer and more on managemylife.com -- for free!

- Find this and all your other product manuals online.
- Get answers from our team of home experts.
- Get a personalized maintenance plan for your home.
- Find information and tools to help with home projects.



brought to you by Sears

PARTS LIST

Craftsman Snow Thrower Model 247.883961

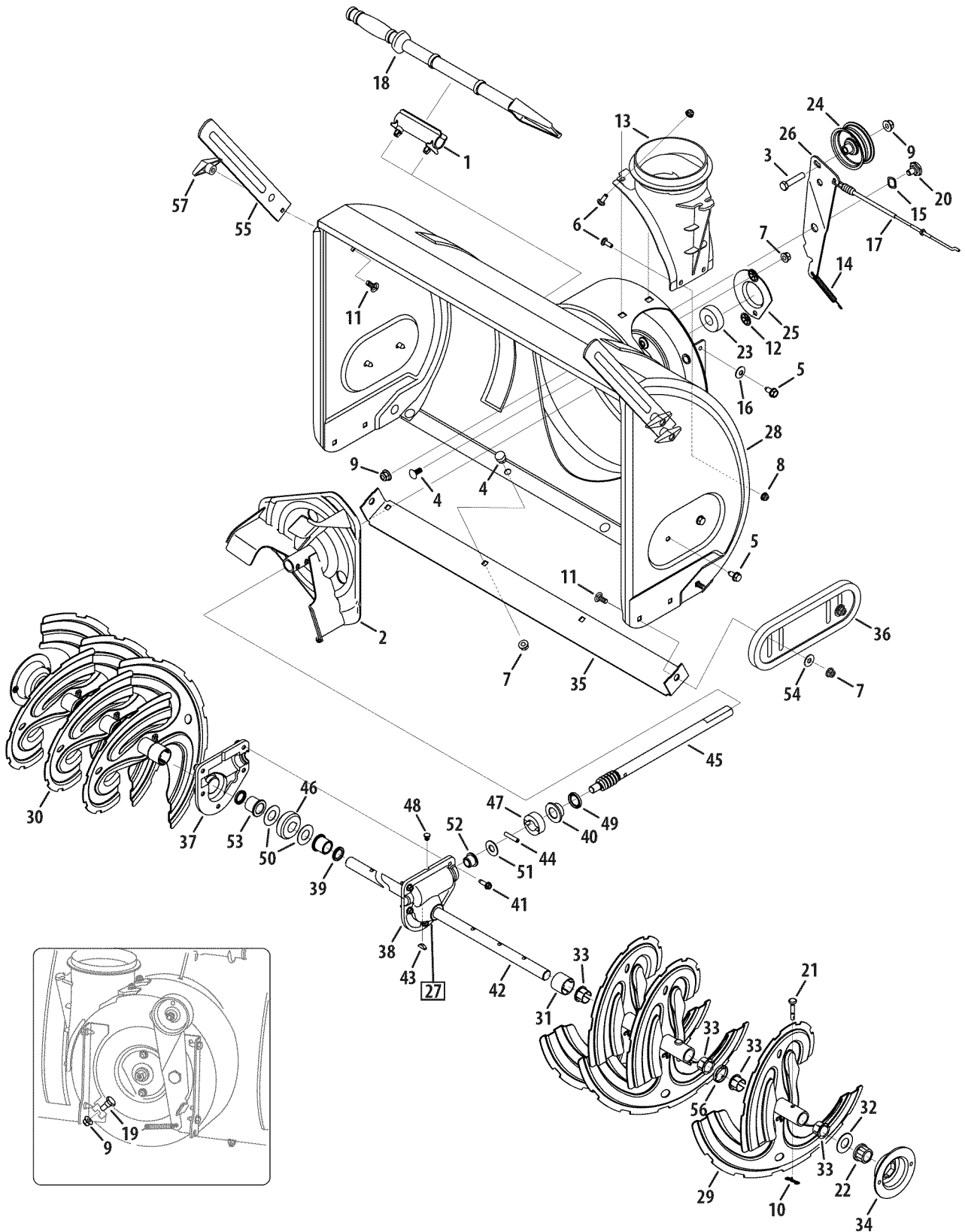

PARTS LIST

Craftsman Snow Thrower Model 247.883961

Ref. No.	Part No.	Description	Ref. No.	Part No.	Description
1.	731-2635	Snow Removal Tool Mount	30.	684-04108-4044	Spiral Assembly, RH
2.	684-04057A-0637	Impeller Assembly, 12" Dia.	31.	731-04870	Spacer, 1.25 OD x .75 ID x 1.00
3.	710-0347	Hex Screw, 3/8-16, 1.75, Gr5	32.	736-0188	Washer, Flat, .76 x 1.49 x .06
4.	710-0451	Bolt, Carriage, 5/16-18, .750 Gr1	33.	741-0493A	Bushing, Flange, .80 ID x .91 OD
5.	710-04484	Screw, 5/16-18, 0.750	34.	790-00087A-0637	Housing, 1" Hex Bearing
6.	710-0703	Screw, Carriage, 1/4-20, .750, Gr5	35.	790-00119-0691	Shave Plate, 2.25 x 29.66
7.	712-04063	Nut, Flange Lock, 5/16-18, Nylon	36.	731-05984A	Slide Shoe
8.	712-04064	Nut, Flange Lock, 1/4-20, Nylon	37.	918-0123A	Housing, Auger, RH Reduced
9.	712-04065	Nut, Flange Lock, 3/8-16, Nylon	38.	918-0124A	Housing, Auger, LH Reduced
10.	714-04040	Cotter Pin, Bow-tie	39.	921-0338	Seal, Oil, .750 x 1.00 x .125
11.	710-0276	Scr., Crg., 5/16-18 x 1.00	40.	741-0662	Bearing, Flange, .75 x 1.0 x .59
12.	926-04012	Nut, Push-on, .25 Dia	41.	710-0642	Screw, Self-tapping, 1/4-20, 0.750
13.	731-07525	Chute, Adapter 5" Dia	42.	711-04282	Axle, Auger, 30"
14.	732-04460	Spring, Extension, .38 OD x 4.59	43.	914-0161	Key, Hi-pro 3/16 x 5/8
15.	736-0174	Washer, Wave, .625 x .885 x .015	44.	715-04021	Pin, Dowel, .25 OD x 1.2
16.	736-0242	Washer, Bell, .340 x .872 x .060	45.	917-04126	Shaft, Worm .75 OD
17.	946-04230A	Clutch Cable, Auger, 47.23"	46.	917-0528A	Gear, Worm 20T
18.	931-2643	Snow Removal Tool	47.	718-04071	Collar, Thrust
19.	738-0143	Screw, Shoulder, .498 x .34, 3/8-16	48.	721-0325	Plug, 1/4 x .437
20.	938-0281	Screw, Shoulder, .625 x .17, 3/8-16	49.	721-0327	Seal, Oil, .75 x 1 x .131
21.	738-04124A	Shear Pin, .25 x 1.50	50.	936-0351	Washer, Flat, .760 ID x 1.5 OD
22.	941-0245	Bearing, Hex Flange x .75 ID	51.	736-3084	Washer, Flat, .51 x 1.12
23.	941-0309	Bearing, Ball, .75 ID x 1.85 OD	52.	741-0663	Bearing, Flange, .75 x 1.0 x .925
24.	756-04224	Flat Pulley, Idler, 2.75 OD	53.	741-0661B	Bearing, Flange, .75 x 1.00 x .975
25.	790-00075	Housing, Bearing, 1.85 ID	54.	936-0159	Washer, Flat, .349 x .879 x .063
26.	790-00080A-0637	Bracket, Auger Idler w/ Brake	55.	790-00181-0637	Drift Cutter
27.	918-04165A	Gearbox Assembly, Auger, 30"	56.	731-04871	Spacer, 1.25 OD x .75 ID x 3/16
28.	684-04267-0691	Housing Assembly, Auger 30"	57.	920-0284	Wing Nut
29.	684-04107-4044	Spiral Assembly, LH			

PARTS LIST

Craftsman Snow Thrower Model 247.883961

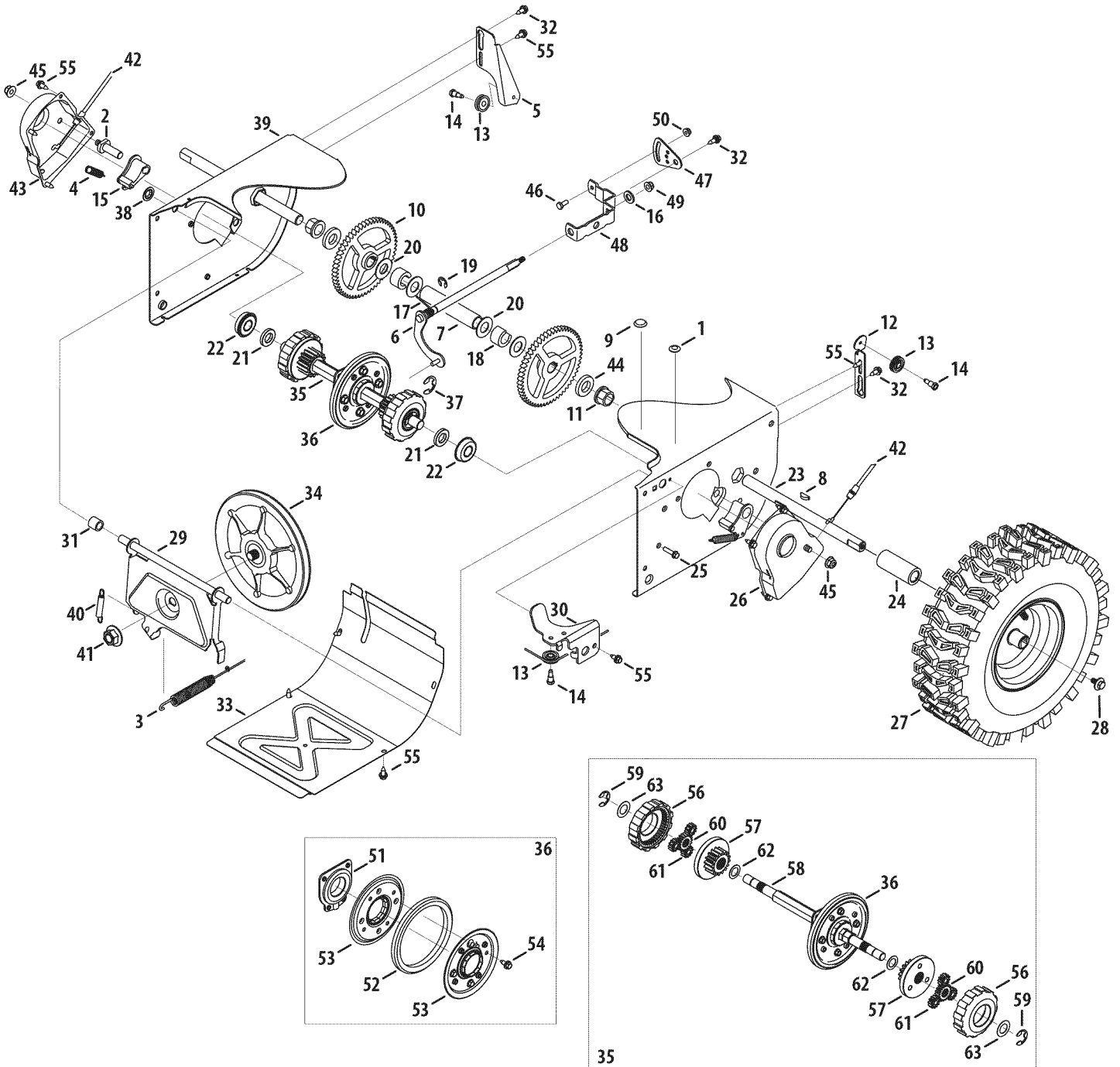

PARTS LIST

Craftsman Snow Thrower Model 247.883961

Ref. No.	Part No.	Description	Ref. No.	Part No.	Description
1.	735-04099	Plug, 3/8 ID	32.	738-04184A	Shoulder Screw
2.	711-1268B	Actuator Shaft	33.	790-00316-0691	Frame Cover
3.	946-05067	Drive Clutch Cable	34.	656-04055	Friction Wheel Disc Assembly
4.	732-04345	Extension Spring	35.	918-06072	Drive Shaft Assembly
5.	790-00207C	Drive Clutch Cable Guide Bracket	36.	684-04153C	Friction Wheel Assembly
6.	684-04156A	Shift Rod Assembly	37.	716-0136	Retainer Ring
7.	750-04474	Axle Support Tube	38.	726-0221	Speed Nut
8.	914-0126	Hi Pro Key	39.	790-00183C-0691	Wheel Drive Frame
9.	735-04100	Plug, 1/2 ID	40.	932-0264	Extension Spring
10.	917-04210	Gear, 56T	41.	712-0417A	Flange Nut, 5/8-18
11.	941-0245	Hex Flange Bearing	42.	946-0956C	Steering Cable
12.	790-00206A-0637	Auger Clutch Cable Guide Bracket	43.	790-00528-0691	Shaft Retainer - RH
13.	756-0625	Cable Roller	44.	750-0767	Axle Spacer
14.	738-0924A	C Screw, 1/4-28 x 0.375	45.	712-04065	Flange Lock Nut, 3/8-16
15.	618-06988	Dogg Assembly - LH	46.	710-0751	Hex Screw, 1/4-20 x .620
	618-06987	Dogg Assembly - RH	47.	790-00217A-0637	Speed Selector Pivot Bracket
16.	936-3015	Washer, Flat	48.	790-00218A-0637	Speed Selector Shift Bracket
17.	732-04311A	Torsion Spring, .750 ID x .968 Lg.	49.	712-04063	Flange Lock Nut, 5/16-18
18.	731-05297	Spacer	50.	712-04064	Flange Lock Nut, 1/4-20
19.	916-0104	E Ring	51.	618-0063A	Friction Wheel Bearing Assembly
20.	736-0188	Flat Washer, .76 x 1.49 x .06	52.	935-04054	Friction Wheel
21.	750-06087	Spacer	53.	790-00174C	Friction Plate
22.	941-0563	Ball Bearing	54.	710-04484	Screw, 5/16-18 x .750
23.	938-04180	Axle	55.	710-1652	AB Screw, 1/4-20 x 0.625
24.	731-04873	Spacer	56.	918-06054	Gear Assembly, Plantry Ring
25.	710-0788	TT Screw, 1/4-20 x 1.0	57.	918-06056	Carrier Assembly, Plantry Ring
26.	790-00527-0691	Shaft Retainer - LH	58.	711-06117	Shaft, Strbl Drv Hex, .812
27.	634-04136-0911	Wheel Complete - LH	59.	916-0231	E-Ring
	634-04137-0911	Wheel Complete - RH	60.	717-05146	Gear, Sun, 18T
28.	710-05339	Screw, 5/16-24 x 0.75	61.	717-1209A	Gear, 12T
29.	684-04154B-0637	Friction Wheel Support Brkt. Assy.	62.	736-04581	Washer, Thrust, .75 x 1.25 x .03
30.	790-00096A-0637	Auger Cable Guide Bracket	63.	736-05031	Washer, Flat, .67 x 1.174 x .02
31.	748-0190	Spacer			

PARTS LIST

Craftsman Snow Thrower Model 247.883961

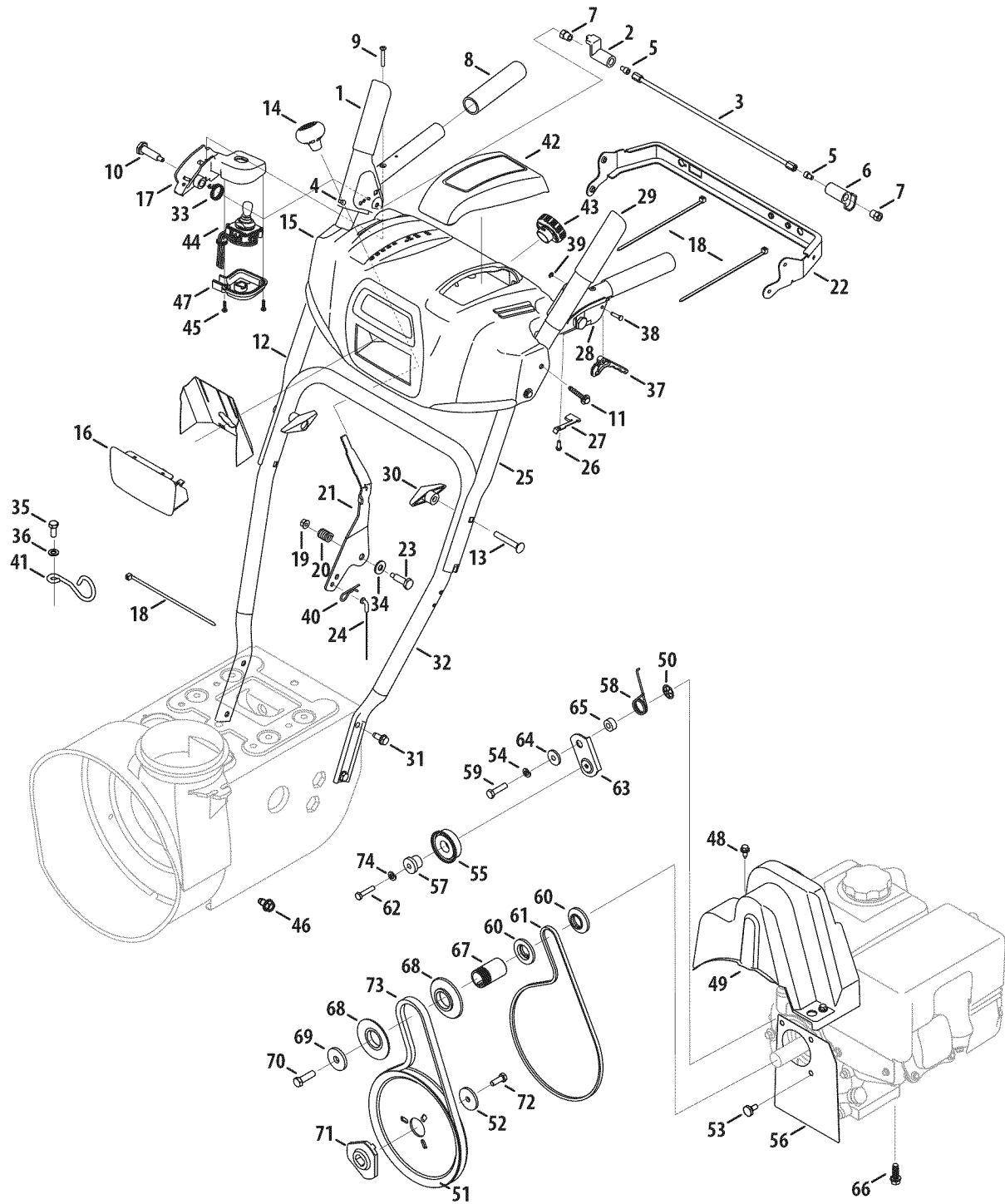

PARTS LIST

Craftsman Snow Thrower Model 247.883961

Ref. No.	Part No.	Description	Ref. No.	Part No.	Description
1.	684-04112C	Handle Engagement Ass'y RH	39.	716-04036	E-Ring
2.	731-04894D	Lock Plate	40.	914-0145	Click Pin
3.	684-04250	Pivot Rod	41.	732-04677	Cable Guide
4.	935-0199A	Rubber Bumper	42.	731-08947	Handle Panel Cover
5.	710-3069	Screw, 1/4-20 x .500	43.	925-06095	LED Light Socket
6.	731-04896B	Clutch Lock Cam	44.	725-06090	Electric Chute Harness
7.	712-04081A	Shoulder Nut, 1/4-20	45.	710-04329	Screw, .159 OD x .610
8.	720-0274	Grip	46.	710-0599	Screw (For ground wire)
9.	710-1233	Screw, #10-24 x 0.375	47.	731-08876	Joystick Housing Cover
10.	738-04348	Shoulder Screw, 1/4-20	48.	710-1652	AB Screw, 1/4-20 x 0.625
11.	710-04586	Screw, 1/4-20 x 1.625	49.	731-06401	Belt Cover
12.	749-04190A-0691	Upper Handle RH	50.	926-04012	Push-on Nut
13.	710-0572	Carriage Screw, 5/16-18 x 2.25	51.	756-04109	Auger Pulley
14.	720-04039	Shift Knob	52.	736-0505	Flat Washer
15.	931-04187A	Handle Panel	53.	738-04439	Shoulder Screw
16.	731-05324	Lens	54.	936-0119	Lock Washer
17.	931-04653	Handle Clutch Lock Assembly - RH	55.	684-04169	Idler Pulley Assembly
18.	725-0157	Cable Tie	56.	790-00332-0637	Plt., Cvr.
19.	712-04064	Flange Lock Nut, 1/4-20	57.	750-04571	Spacer
20.	732-0193	Compression Spring	58.	732-04308A	Torsion Spring
21.	790-00311B-0637	Shift Lever	59.	710-0672	Hex Screw, 5/16-24 x 1.25
22.	790-00248C-0637	Panel Bracket	60.	756-04252	Pulley Half
23.	738-04125	Shoulder Screw	61.	954-04201A	Belt, Wheel Drive
24.	946-04396A	Speed Selector Cable	62.	710-0809	TT Screw, 1/4-20 x 1.25
25.	749-04191A-0691	Upper Handle LH	63.	790-00208D	Drive Clutch Idler Bracket
26.	710-04326	Screw, #8-16 x 0.50	64.	748-04112B	Shoulder Spacer
27.	732-04219C	Clutch Lock Spring	65.	750-04477A	Spacer
28.	631-04133A	Handle Clutch Lock Assembly - LH	66.	710-0654A	TT Sems Screw, 3/8-16 x 1.0
29.	684-04111B	Handle Engagement Assembly LH	67.	750-04303	Spacer
30.	920-0284	Wing Knob	68.	756-04113	Pulley Half
31.	710-04484	Screw, 5/16-18 x 0.75	69.	736-3082A	Flat Washer
32.	749-04138B-0691	Lower Handle	70.	710-0191	Hex Bolt, 3/8-24 x 1.25
33.	732-04238	Torsion Spring	71.	748-04053A	Pulley Adapter
34.	936-0267	Flat Washer	72.	710-1245B	Hex Bolt, 5/16-24 x 0.875
35.	710-04022	Screw, M8-1.25	73.	954-04195A	V-Belt, .500 x 35.00 Lg
36.	936-0264	Flat Washer, .330 x .630 x .0635	74.	936-0329	Lock Washer
37.	731-06113	Steering Control	N/A		Engine (see breakdown)
38.	738-04126	Pin, 3/16			MTD Model No. 952Z483-SUB

PARTS LIST

Craftsman Snow Thrower Model 247.883961

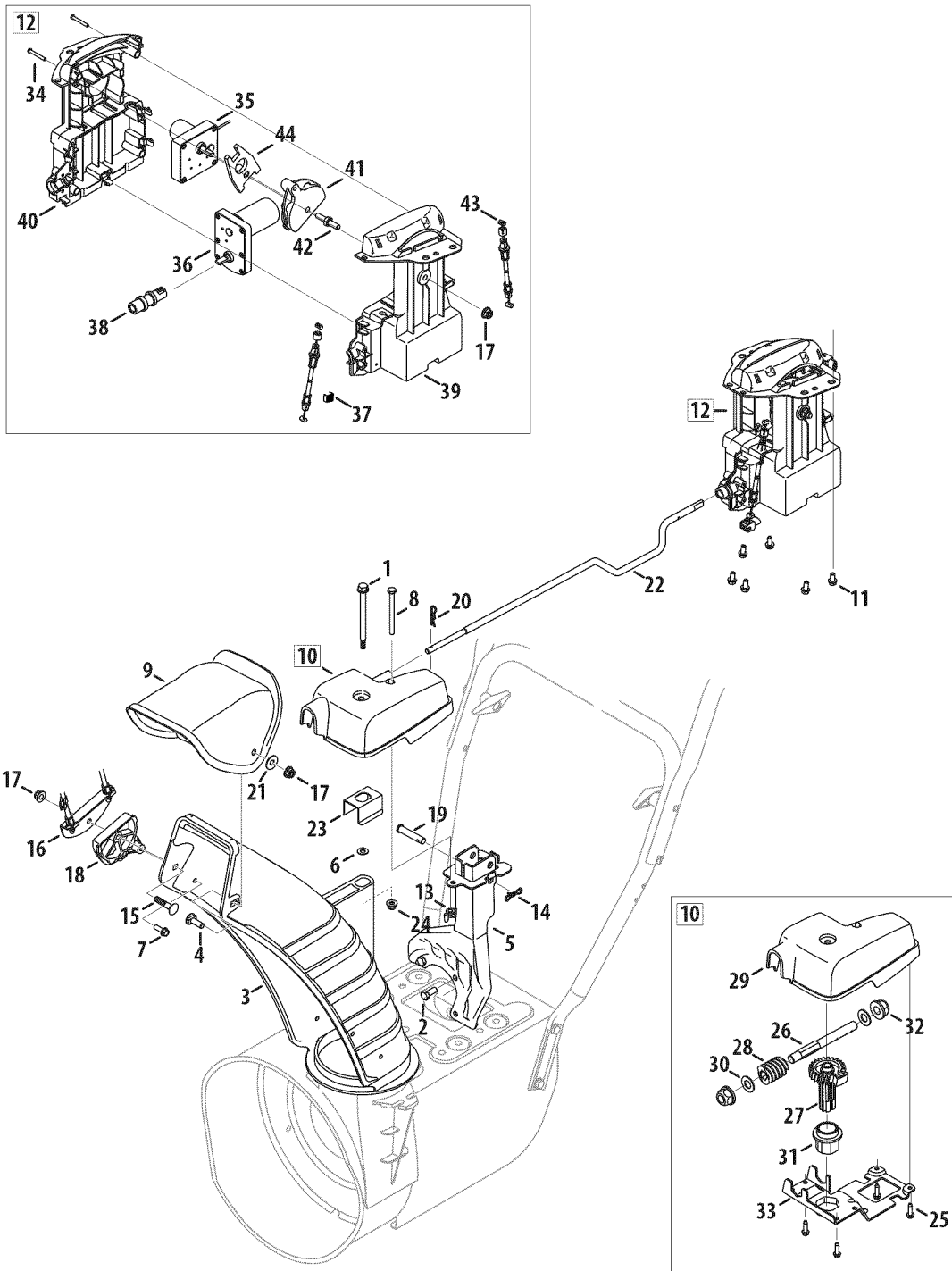

PARTS LIST

Craftsman Snow Thrower Model 247.883961

Ref. No.	Part No.	Description
1.	738-04367	Flange Shoulder Screw
2.	710-0627	Hex Screw, 5/16-24 x .750
3.	731-06440A	Lower Chute
4.	710-04071	Carriage Bolt, 5/16-18 x 1.0
5.	684-04310A-0637	Chute Support Bracket
6.	736-04446	Flat Washer, .25 x .630 x .0515
7.	710-0895	Hi-Lo Screw, 1/4-15 x .75
8.	710-04370	Hex Screw, 1/4-20 x 3.00
9.	731-04427A	Upper Chute
10.	918-04932A	Electric Chute Gearbox Assembly
11.	710-04187	Hi-Lo Screw, 1/4-15 x 0.5
12.	684-05051	Electric Chute Control Assembly
13.	712-3087	Wing Nut, 1/4-20
14.	714-04040	Bow Tie Cotter Pin
15.	710-0262	Carriage Bolt, 5/16-18 x 1.50
16.	784-5594-0637	Cable Bracket
17.	712-04063	Flange Lock Nut, 5/16-18
18.	731-06451	Chute Tilt Cable Guide
19.	711-04469A	Clevis Pin
20.	914-0101	Cotter Pin
21.	936-0159	Flat Washer, .349 x .879 x .063
22.	747-05721	Chute Rod
23.	790-00503	Chute Bracket

Ref. No.	Part No.	Description
24.	712-04064	Flange Lock Nut, 1/4-20
25.	710-04373A	Screw, #12-16 x .75
26.	911-05752	Shaft, Worm Drive
27.	917-04973A	Gear, Helical
28.	917-05019	Worm, 2-Start Nylon
29.	731-07529A	Cover, Gear, Chute Control
30.	936-0272	Wash., Flat, .510 x 1.00 x .060
31.	741-04388A	Bearing, Flange, 1.00 ID
32.	741-04453A	Bearing, Flange, .50 ID
33.	790-00342B-0637	Brkt., Gear, Chute Rotation
34.	710-04509	Scr., AB, #10-16 x 1.25
35.	724-04209	Motor, Pitch, Chute
36.	724-04210	Motor, Rotate, Chute
37.	731-07868	Clip, Cable
38.	731-08795	Coupler, Electric Chute
39.	731-08845A	Hsg., LH, 4-Way, Chute Control
40.	731-08846	Hsg., RH, 4-Way, Chute Control
41.	731-1313C	Gde., Cbl., Chute Tilt
42.	938-0849	Scr., Hex, 5/16-18 x .75
43.	946-04528B	Cbl., Snow, 4-Way, Tall Chute
44.	748-04297A	Adpt., Pitch, Chute
—	753-08018†	Chute Kit (Incl. Ref.# 3 & 9)

† Available for warranty coverage only. Contact a Sears authorized service provider for details.

PARTS LIST

Craftsman Engine Model 483-SUB For Snow Model 247.883961

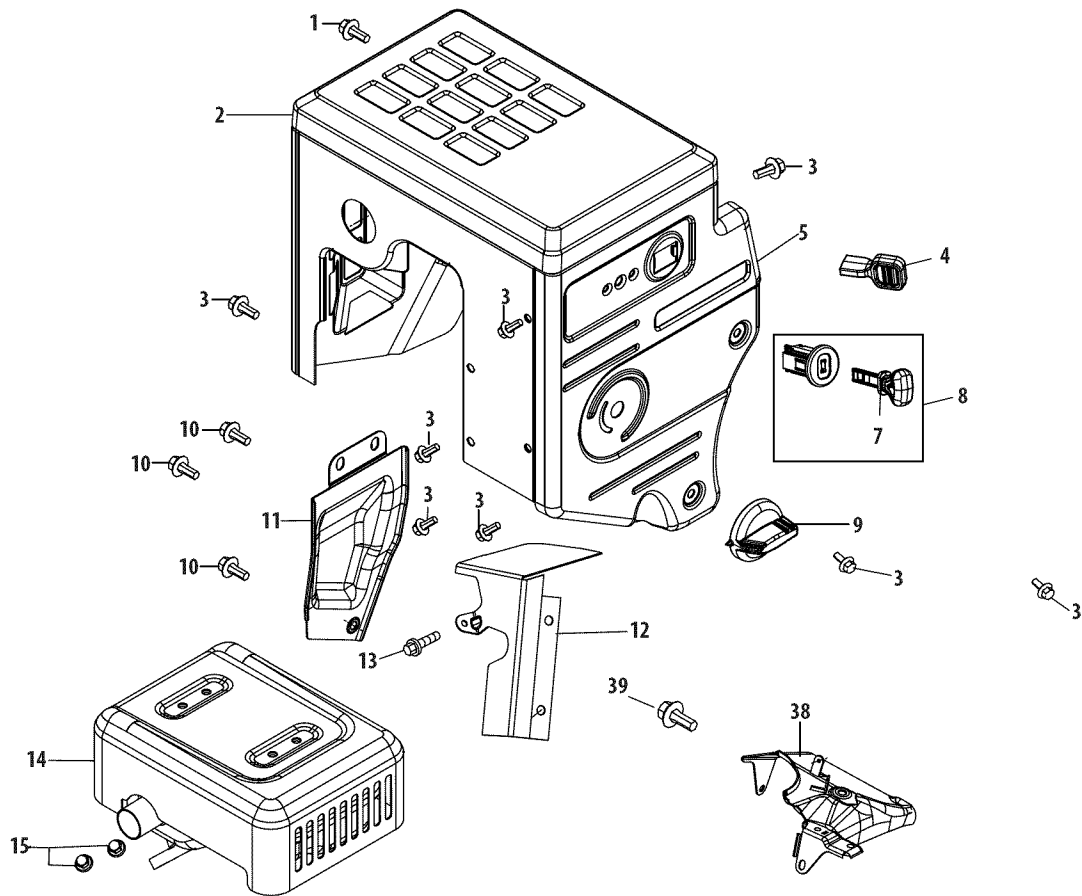

Ref.	Part No.	Description
1	710-04915	Bolt M6×12
2	951-11339	Muffler Shield
3	710-04915	Bolt M6×12
4	951-10757	Throttle Control Knob
5	951-11595	Control Panel
7	731-05632	Key
8	951-10637	Key Switch Assembly
9	951-11302	Choke Knob
10	710-04914	Bolt M6×10
11	951-11181	Exhaust Pipe Shield
12	951-11321	Carburetor Heat Shield
13	710-04968	Bolt M6×16
14	951-11338	Muffler Assembly
15	712-05015	Nut, M8
38	951-11311	Throttle Control Assembly
39	710-04915	Bolt M6×12

PARTS LIST

Craftsman Engine Model 483-SUB For Snow Model 247.883961

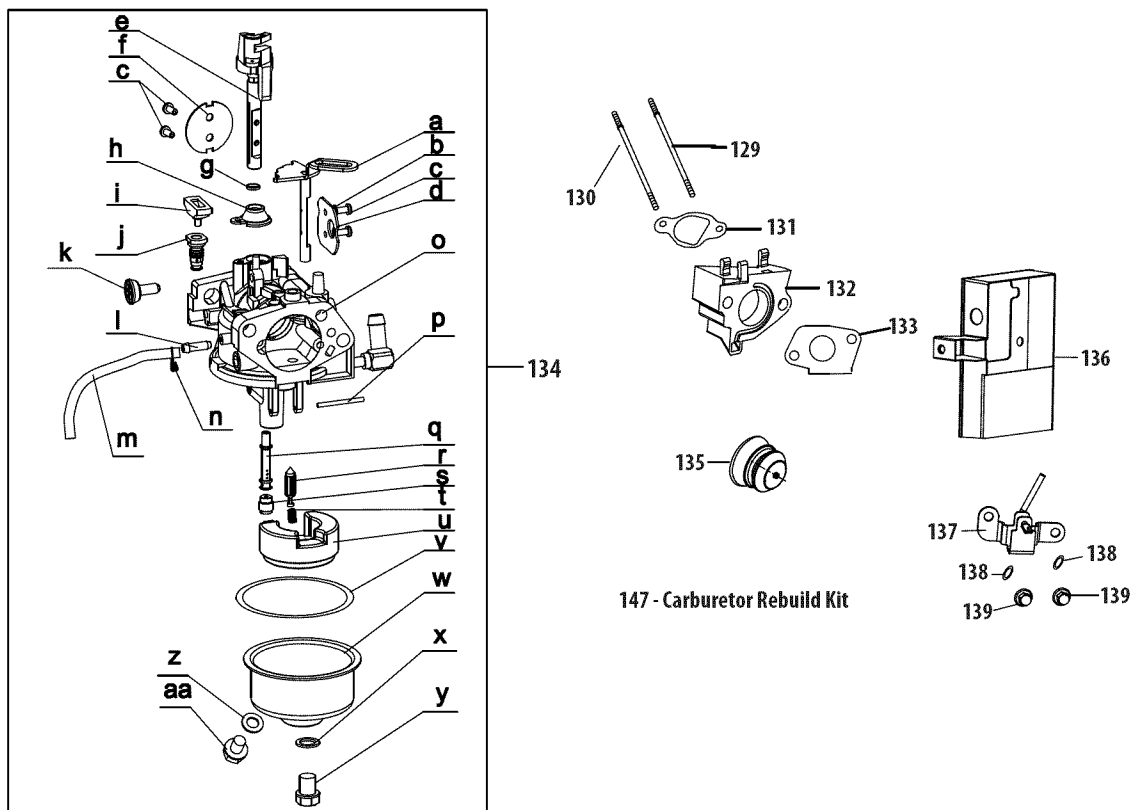

Ref.	Part No.	Description
129	710-05392	Stud M6-8x100
130	710-05056	Stud M6-8x118
131	951-11315	Carburetor Intake Gasket
132	951-11316	Carburetor Insulator
133	951-11223	Carburetor Gasket
134	951-14023A	Carburetor Assembly
135	951-10639A	Primer Assembly
135	951-11824	Primer Bulb
136	951-11304	Heater Box
137	951-11192	Choke Assembly
138	736-04477	Lock Washer
139	712-05015	Nut M6
147	951-12760A	Carburetor Rebuild Kit (Inc.i,j,p,q,r,s,t,u,v,x,z)
a	n/a	Choke Shaft
b	736-04638	Choke Control Lever Washer
c	710-05469	Fuel Shutoff Lever Screw
d	n/a	Choke Plate
e	n/a	Throttle Shaft
f	n/a	Throttle Plate
g	n/a	Gasket

Ref.	Part No.	Description
h	n/a	Throttle Shaft Cover
i	n/a	Idle Jet Rivet
j	n/a	Idle Jet Assembly
k	n/a	Idle Speed Adjusting Screw
l	n/a	Primer Pipe
m	751-11991	Primer Hose
n	951-11906	Primer Hose Clamp
o	n/a	Carburetor Body
p	n/a	Float Pin
q	n/a	Emulsion Tube
r	n/a	Nickel Plated Brass Needle Valve
s	n/a	Main Jet
t	n/a	Needle Valve Spring
u	n/a	Float
v	951-11970	Fuel Bowl Gasket
w	n/a	Fuel Bowl
x	951-11348	Fuel Bowl Gasket
y	710-04945	Fuel Bowl Mounting Bolt
z	951-11349	Fuel Drain Plug Gasket
aa	710-04938	Fuel Drain Plug

PARTS LIST

Craftsman Engine Model 483-SUB For Snow Model 247.883961

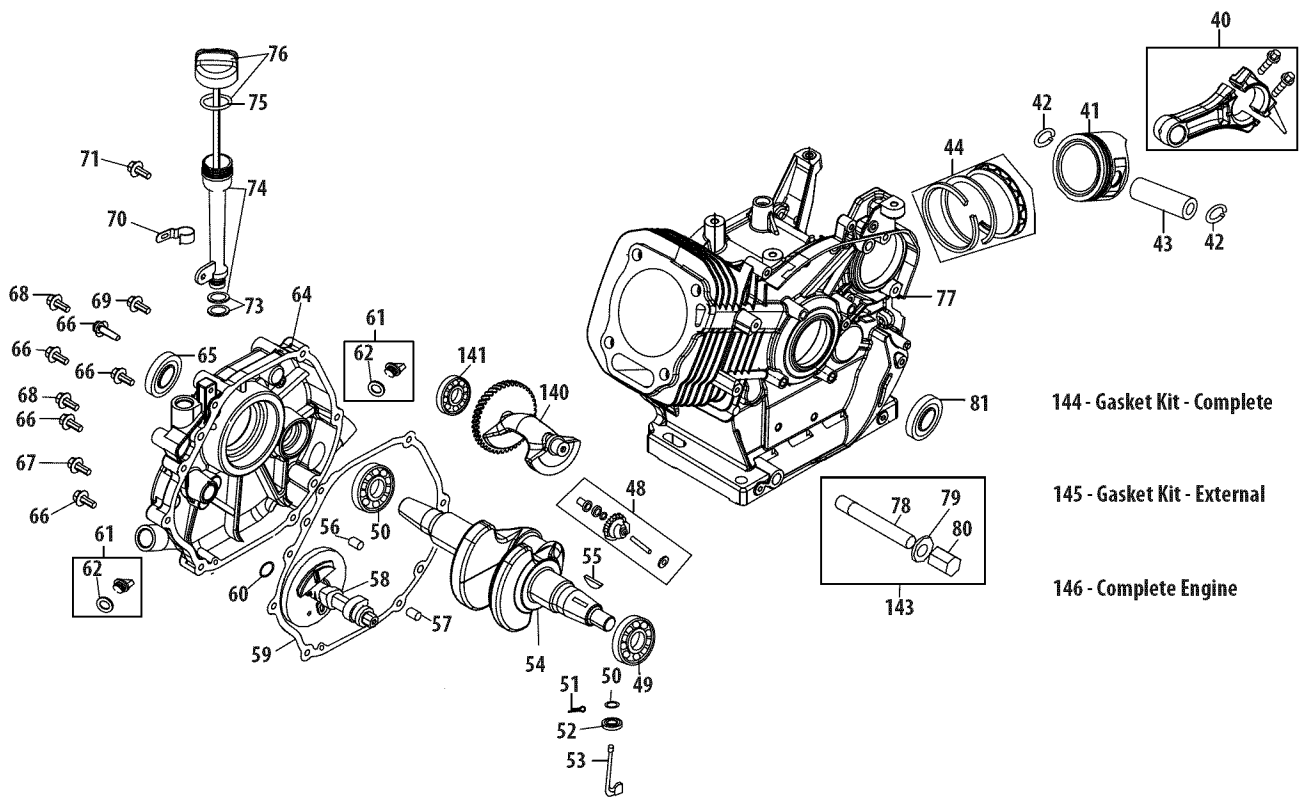

144 - Gasket Kit - Complete

145 - Gasket Kit - External

146 - Complete Engine

PARTS LIST

Craftsman Engine Model 483-SUB For Snow Model 247.883961

Ref.	Part No.	Description	Ref.	Part No.	Description
40	951-11951	Connecting Rod Assembly	67	710-06062	Bolt M8x45
41	951-11952	Piston	68	710-06063	Bolt M8x35
42	951-11953	Piston Pin Snap Ring	69	710-04968	Bolt M6x16
43	951-11954	Piston Pin	70	951-11320	Oil Tube Support Bracket
44	951-12579	Piston Ring Set	71	710-05349	Bolt M6x8
48	951-11956	Governor Gear/Shaft Assembly	73	951-11381	Oil Fill Tube O-Ring
49	951-11373	Radial Ball Bearing	74	951-12073	Oil Fill Tube Assembly
50	736-04453	Flat Washer	75	951-11904	Dipstick O-Ring
51	714-04077	Governor Shaft Clip	76	951-11971A	Dipstick Assembly
52	951-11958	Governor Seal	77	951-11341A	Crankcase Kit (Inc.49,52,77,81)
53	951-11365	Governor Arm Shaft		951-11328B	Short Block Assembly
54	951-11342	Crankshaft Kit (Inc.49,54,55,65,81)			(Inc.40-44,48-68,77-81,102,105,106,108 110,111, 125,131,132,140,141)
55	951-10307	Woodruff Key	78	951-11350	Oil Drain Pipe
56	715-04102	Dowel Pin 9 X 12	79	736-04440	Drain Pipe Washer 10X16X1.5
57	715-04092	Dowel Pin 7 X 14	80	710-04906	Oil Drain Plug Bolt
58	951-11959	Camshaft Assembly	81	951-11499	Oil Seal
59	951-11376	Crankcase Cover Gasket	140	951-11968	Balance Gear Assembly
60	736-04545	Washer	141	951-11969	Bearing
61	951-11283	Oil Fill Plug Assembly	143	951-10641	Oil Drain Asm
62	951-11577	O-Ring	144	951-11330A	Gasket Kit - Complete
64	951-14220	Crankcase Cover			(Inc.52,59,65,79,81,106, 108,125,131-133)
	951-11340	Crankcase Cover Kit (Inc.49,59,60,64-68)	145	951-11331	Gasket Kit - External
65	951-11375	Oil Seal			(Inc.79,108,125,131-133)
66	710-06061	Bolt M8x38	146	952Z483-SUB	Complete Engine

PARTS LIST

Craftsman Engine Model 483-SUB For Snow Model 247.883961

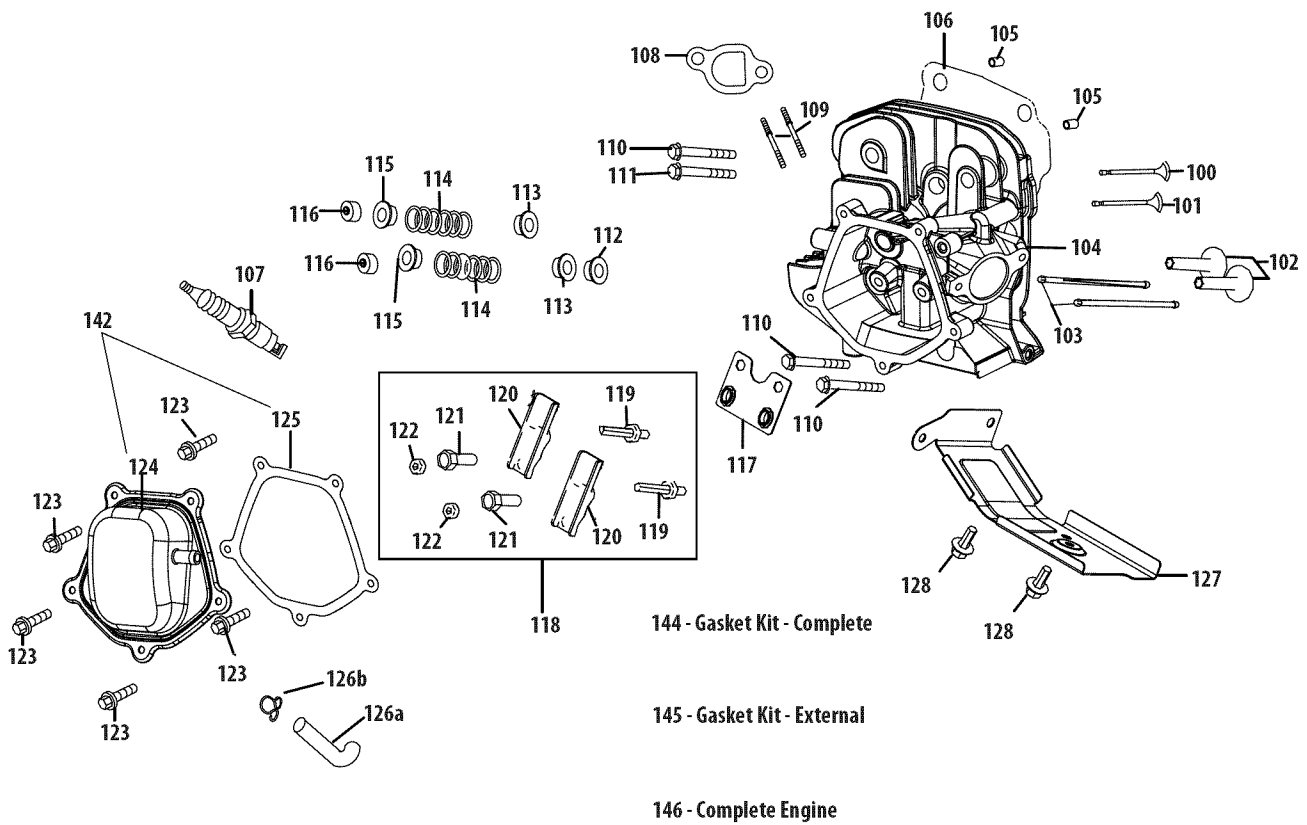

PARTS LIST

Craftsman Engine Model 483-SUB For Snow Model 247.883961

Ref.	Part No.	Description	Ref.	Part No.	Description
100	951-11337	Valve Kit	116	951-12081	Exhaust Lash Cap
101	951-11337	Valve Kit	117	951-11965	Push Rod Guide
102	951-11962	Tappet	118	951-11981	Rocker Arm Assembly
103	951-11335	Push Rod Kit	119	710-04962	Bolt, Pivot
104	951-12555	Cylinder Head Kit (Inc.106,110-112,125)	120	951-11966	Rocker Arm
	951-11329B	Cylinder Head Assembly (Inc.100,101,104,106,108-112, 114-122,125,129-133)	121	751-11123	Adjusting Nut ,Valve
105	715-04097	Dowel Pin	122	751-11124	Pivot Locking Nut
106	951-11963	Cylinder Head Gasket	123	710-05054	Valve Cover Bolt
107	951-10292	Spark Plug/F6Rtc	124	951-11220	Valve Cover
108	951-11212	Muffler Gasket	125	951-11967	Valve Cover Gasket
109	710-04964	Exhaust Stud M8x48.5	126a	731-07059	Breather Hose
109	951-11207	Muffler Stud Assembly	126b	726-04101	Breather Hose Clamp
110	710-06064	Bolt M10x1.25x87	127	951-11317	Cylinder Baffle
111	710-06065	Bolt M10x1.25x65	128	710-04915	Bolt M6x12
112	951-11964	Intake Valve Seal	142	951-11333	Valve Cover Kit
113	951-12077	Intake Valve Spring Retainer	144	951-11330A	Gasket Kit - Complete (Inc.52,59,65,79,81,106,108,125,131-133)
114	951-12078	Valve Spring	145	951-11331	Gasket Kit - External (Inc.79,108,125,131-133)
115	951-12080	Exhaust Valve Spring Retainer	146	952Z483-SUB	Complete Engine

PARTS LIST

Craftsman Engine Model 483-SUB For Snow Model 247.883961

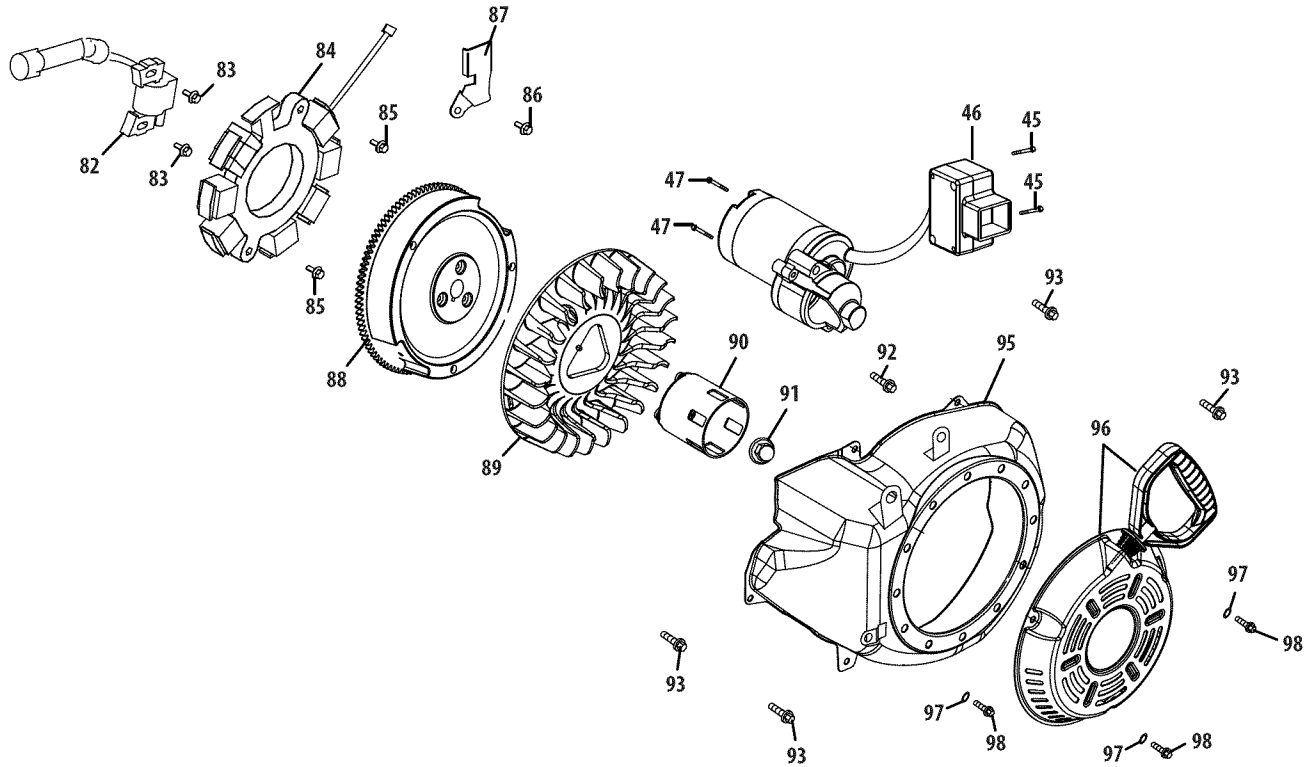

Ref.	Part No.	Description
45	710-04965	Screw M4 X 55
46	951-11196	Electric Starter
47	710-04967	Bolt M8x55
82	951-11305	Ignition Coil Assembly
83	710-05350	Ignition Coil Bolt
84	951-12553	Alternator Assembly
85	710-04969	Bolt M6x30
86	710-04966	Bolt M6x8
87	951-11186	Alternator Wire Clamp Bracket
88	951-12556	Flywheel

Ref.	Part No.	Description
89	951-11313	Cooling Fan
90	951-11314	Starter Cup
91	712-04220	Flywheel Nut, M14x1.5
92	710-04968	Bolt M6x16
93	710-04915	Bolt M6x12
95	951-11211	Blower Housing
96	951-14223	Recoil Starter Assembly
97	736-04455	Flat Washer
98	710-04974	Bolt M6x10

PARTS LIST

Craftsman Engine Model 483-SUB For Snow Model 247.883961

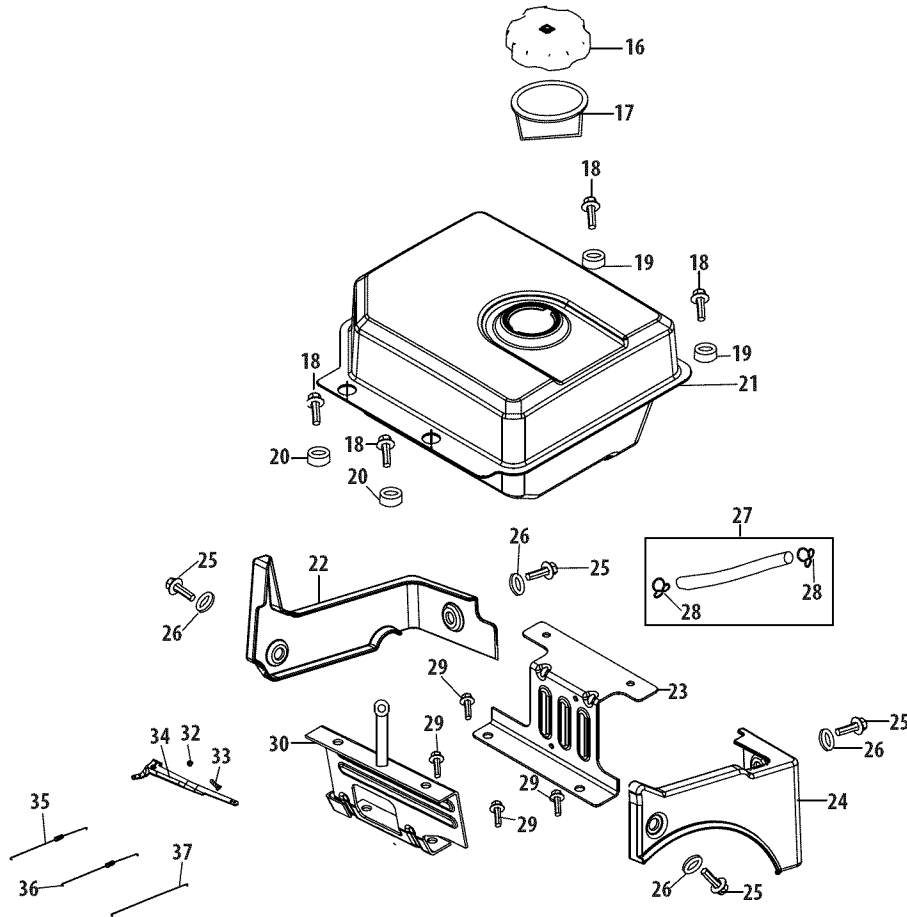

Ref.	Part No.	Description
16	951-12533	Fuel Cap Assembly
17	951-11933	Fuel Level Indicator
18	710-04970	Bolt M8×20
19	750-05312	Bushing, Slot
20	750-05313	Bushing, Rnd
21	951-11201	Fuel Tank Assembly
22	951-11319	Fuel Tank Shroud
23	951-11318	Fuel Tank Mounting Bracket
24	951-11351	Engine Shroud
25	710-04968	Bolt M6×16
26	736-04452	Bush

Ref.	Part No.	Description
27	951-11336	Fuel Line Kit
28	951-11700	Fuel Hose Clamp
29	710-04921	Bolt M8×14
30	951-11182	Fuel Tank Mounting Bracket
32	712-04212	Flange Nut M6
33	710-04908	Governor Arm Bolt M6X21
34	951-11307	Governor Arm
35	951-11306	Governor Spring
36	951-11203	Throttle Return Spring
37	951-11309	Governor Rod

PARTS LIST

Craftsman Snow Thrower Model 247.883961

777S32636

CLEAN-OUT TOOL

1. KEEP AWAY FROM ROTATING IMPELLER AND AUGER. CONTACT WITH IMPELLER OR AUGER CAN AMPUTATE HANDS AND FEET.
2. USE CLEAN-OUT TOOL TO UNCLOG DISCHARGE CHUTE.
3. DISENGAGE CLUTCH LEVERS, STOP ENGINE, AND REMAIN BEHIND HANDLES UNTIL ALL MOVING PARTS HAVE STOPPED BEFORE UNBLOCKING OR SERVICING MACHINE.
4. TO AVOID THROWN OBJECTS INJURIES, NEVER DIRECT DISCHARGE AT BYSTANDERS. USE EXTRA CAUTION WHEN OPERATING ON GRAVEL SURFACES.
5. READ OPERATOR'S MANUAL.

▲ DANGER

▲ DANGER



AVOID INJURY FROM ROTATING AUGER - KEEP HANDS, FEET AND CLOTHING AWAY.

777I25002

STARTING INSTRUCTIONS: 

- 1.) INSERT KEY AND SNAP IN PLACE.
- 2.) MOVE THROTTLE CONTROL TO THE "FAST" POSITION.
- 3.) MOVE CHOKE CONTROL TO THE "CHOKE" POSITION. PUSH PRIMER 3x.
- 4.) ROPE START: PULL SLOWLY UNTIL HARDER TO PULL, THEN PULL RAPIDLY TO START. REPEAT PRIMING IF NEEDED.
ELECTRIC START: DO NOT USE IN RAIN. CONNECT POWER CORD AND PUSH STARTER BUTTON. REPEAT PRIMING IF NEEDED.
- 5.) MOVE CHOKE CONTROL SLOWLY TO THE "RUN" POSITION.
- 6.) TO STOP ENGINE: MOVE THROTTLE TO THE "STOP" POSITION.

ELECTRIC CHUTE DIRECTIONAL CONTROL

CHUTE TILT DOWN



CHUTE ROTATE LEFT CHUTE ROTATE RIGHT

CHUTE TILT UP

777S32236

▲ DANGER



- NEVER PUT HAND IN CHUTE. CONTACT WITH ROTATING PARTS CAN AMPUTATE FINGERS AND HANDS.
- SHUT OFF ENGINE AND WAIT UNTIL ALL MOVING PARTS HAVE STOPPED BEFORE UNBLOCKING.
- USE CLEAN-OUT TOOL OR WOODEN STICK TO UNBLOCK DISCHARGE CHUTE.

777D19077



777D16340







777I22363

777D16338

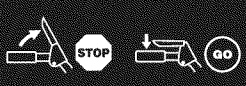

777I22340

777X43688

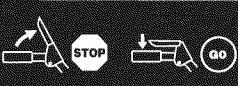
<p>← AUGER CONTROL </p> 	<p>LEFT TURN TRIGGER CONTROL</p> 	<p>RIGHT TURN TRIGGER CONTROL</p> 	<p>DRIVE CONTROL </p> 
---	---	--	--

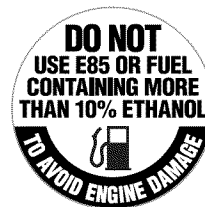

777D18036

CRAFTSMAN



EZ STEER
POWERED STEERING

CLEARING WIDTH **30"**

ELECTRIC START

FEDERAL and/or CALIFORNIA EMISSION CONTROL WARRANTY STATEMENT
YOUR WARRANTY RIGHTS AND OBLIGATIONS

MTD Consumer Group Inc, the United States Environmental Protection Agency (EPA), and for those products certified for sale in the state of California, the California Air Resources Board (CARB) are pleased to explain the emission (evaporative and/or exhaust) control system (ECS) warranty on your 2013 and later small off-road spark-ignited engine and equipment (outdoor equipment engine). In California, new outdoor equipment engines must be designed, built and equipped to meet the State's stringent anti-smog standards (in other states, outdoor equipment engines must be designed, built, and equipped to meet the U.S. EPA small off-road spark ignition engine regulations). MTD Consumer Group Inc must warrant the ECS on your outdoor equipment engine for the period of time listed below, provided there has been no abuse, neglect, or improper maintenance of the outdoor equipment engine.

Your ECS may include parts such as the carburetor, fuel-injection system, ignition system, catalytic converter, fuel tanks, fuel lines, fuel caps, valves, canisters, filters, vapor hoses, clamps, connectors, and other associated emission-related components.

Where a warrantable condition exists, MTD Consumer Group Inc will repair your outdoor equipment engine at no cost to you including diagnosis, parts, and labor.

MANUFACTURER'S WARRANTY COVERAGE:

This emission control system is warranted for two years. If any emission-related part on your outdoor equipment engine is defective, the part will be repaired or replaced by MTD Consumer Group Inc. In the event that a component is covered for longer than two years by the Manufacturer's equipment warranty, the longer coverage period will apply.

OWNER'S WARRANTY RESPONSIBILITIES:

As the outdoor equipment engine owner, you are responsible for performance of the required maintenance listed in your owner's manual. MTD Consumer Group Inc recommends that you retain all receipts covering maintenance on your outdoor equipment engine, but MTD Consumer Group Inc cannot deny warranty solely for the lack of receipts.

As the outdoor equipment engine owner, you should however be aware that MTD Consumer Group Inc may deny you warranty coverage if your outdoor equipment engine or a part has failed due to abuse, neglect, improper maintenance, or unapproved modifications.

You are responsible for presenting your outdoor equipment engine to MTD Consumer Group Inc's distribution center or service center as soon as the problem exists. The warranty repairs should be completed in a reasonable amount of time, not to exceed 30 days. If you have a question regarding your warranty coverage, you should contact the MTD Consumer Group Inc Service Department at 1-800-800-7310 or at <http://support.mtdproducts.com>.

GENERAL EMISSIONS WARRANTY COVERAGE:

MTD Consumer Group Inc warrants to the ultimate purchaser and each subsequent purchaser that the outdoor equipment engine is: (1) designed, built, and equipped so as to conform with all applicable regulations; and (2) free from defects in materials and workmanship that cause the failure of a warranted part for a period of two years.

The warranty period begins on the date the outdoor equipment engine is delivered to an ultimate purchaser or first placed into service.

Subject to certain conditions and exclusions as stated below, the warranty on emission-related parts is as follows:

1. Any warranted part that is not scheduled for replacement as required maintenance in the written instructions supplied is warranted for the warranty period stated above. If the part fails during the period of warranty coverage, the part will be repaired or replaced by MTD Consumer Group Inc according to subsection (4) below. Any such part repaired or replaced under warranty will be warranted for the remainder of the period.
 2. Any warranted part that is scheduled only for regular inspection in the written instructions supplied is warranted for the warranty period stated above. Any such part repaired or replaced under warranty will be warranted for the remaining warranty period.
 3. Any warranted part that is scheduled for replacement as required maintenance in the written instructions supplied is warranted for the period of time before the first scheduled replacement date for that part. If the part fails before the first scheduled replacement, the part will be repaired or replaced by MTD Consumer Group Inc according to subsection (4) below. Any such part repaired or replaced under warranty will be warranted for the remainder of the period prior to the first scheduled replacement point for the part.
 4. Repair or replacement of any warranted part under the warranty provisions herein must be performed at a warranty station at no charge to the owner.
 5. Notwithstanding the provisions herein, warranty services or repairs will be provided at all of our distribution centers that are franchised to service the subject engines or equipment.
 6. The outdoor equipment engine owner will not be charged for diagnostic labor that is directly associated with diagnosis of a defective, emission-related warranted part, provided that such diagnostic work is performed at a warranty station.
 7. MTD Consumer Group Inc is liable for damages to other engine or equipment components proximately caused by a failure under warranty of any warranted part.
 8. Throughout the off-road engine and equipment warranty period stated above, MTD Consumer Group Inc will maintain a supply of warranted parts sufficient to meet the expected demand for such parts.
 9. Any replacement part may be used in the performance of any warranty maintenance or repairs and must be provided without charge to the owner. Such use will not reduce the warranty obligations of MTD Consumer Group Inc.
-

-
10. Add-on or modified parts that are not exempted by the Air Resources Board may not be used. The use of any non-exempted add-on or modified parts by the ultimate purchaser will be grounds for disallowing a warranty claims. MTD Consumer Group Inc will not be liable to warrant failures of warranted parts caused by the use of a non-exempted add-on or modified part.

WARRANTED PARTS:

The repair or replacement of any warranted part otherwise eligible for warranty coverage may be excluded from such warranty coverage if MTD Consumer Group Inc demonstrates that the outdoor equipment engine has been abused, neglected, or improperly maintained, and that such abuse, neglect, or improper maintenance was the direct cause of the need for repair or replacement of the part. That notwithstanding, any adjustment of a component that has a factory installed, and properly operating, adjustment limiting device is still eligible for warranty coverage. Further, the coverage under this warranty extends only to parts that were present on the off-road engine and equipment purchased.

The following emission warranty parts are covered (if applicable):

1. Fuel Metering System
 - Cold start enrichment system (soft choke)
 - Carburetor and internal parts (or fuel injection system)
 - Fuel pump
 - Fuel tank
2. Air Induction System
 - Air cleaner
 - Intake manifold
3. Ignition System
 - Spark plug(s)
 - Magneto ignition system
4. Exhaust System
 - Catalytic converter
 - SAI (Reed valve)
5. Miscellaneous Items Used in Above System
 - Vacuum, temperature, position, time sensitive valves and switches
 - Connectors and assemblies
6. Evaporative Control
 - Fuel hose
 - Fuel hose clamps
 - Tethered fuel cap
 - Carbon canister
 - Vapor lines

REPAIR PROTECTION AGREEMENT

Congratulations on making a smart purchase. Your new Craftsman® product is designed and manufactured for years of dependable operation. But like all products, it may require repair from time to time. That's when having a Repair Protection Agreement can save you money and aggravation.

Here's what the Repair Protection Agreement* includes:

- ☑ **Expert service** by our 10,000 professional repair specialists
- ☑ **Unlimited service and no charge** for parts and labor on all covered repairs
- ☑ **Product replacement** up to \$1500 if your covered product can't be fixed
- ☑ **Discount of 25%** from regular price of service and related installed parts not covered by the agreement; also, 25% off regular price of preventive maintenance check
- ☑ **Fast help by phone** – we call it Rapid Resolution – phone support from a Sears representative. Think of us as a “talking owner's manual.”

Once you purchase the Repair Protection Agreement, a simple phone call is all that it takes for you to schedule service. You can call anytime day or night, or schedule a service appointment online.

The Repair Protection Agreement is a risk-free purchase. If you cancel for any reason during the product warranty period, we will provide a full refund. Or, a prorated refund anytime after the product warranty period expires. Purchase your Repair Protection Agreement today!

Some limitations and exclusions apply. For prices and additional information in the U.S.A. call 1-800-827-6655.

***Coverage in Canada varies on some items. For full details call Sears Canada at 1-800-361-6665.**

Sears Installation Service

*For Sears professional installation of home appliances, garage door openers, water heaters, and other major home items, in the U.S.A. or Canada call **1-800-4-MY-HOME®**.*

Get it fixed, at your home or ours!

Your Home

For troubleshooting, product manuals and expert advice:



www.managemylife.com

For repair – **in your home** – of **all** major brand appliances, lawn and garden equipment, or heating and cooling systems, **no matter who made it, no matter who sold it!**

For the replacement parts, accessories and owner's manuals that you need to do-it-yourself.

For Sears professional installation of home appliances and items like garage door openers and water heaters.

1-800-4-MY-HOME[®] (1-800-469-4663)

Call anytime, day or night (U.S.A. and Canada)

www.sears.com www.sears.ca

Our Home

For repair of carry-in items like vacuums, lawn equipment, and electronics, call anytime for the location of your nearest

Sears Parts & Repair Service Center

1-800-488-1222 (U.S.A.)

www.sears.com

1-800-469-4663 (Canada)

www.sears.ca

To purchase a protection agreement on a product serviced by Sears:

1-800-827-6655 (U.S.A.)

1-800-361-6665 (Canada)

Para pedir servicio de reparación a domicilio, y para ordenar piezas:

1-888-SU-HOGAR[®]

(1-888-784-6427)

www.sears.com

Au Canada pour service en français:

1-800-LE-FOYER^{MC}

(1-800-533-6937)

www.sears.ca

The Sears logo, consisting of the word "sears" in a lowercase, serif font.

® Registered Trademark / TM Trademark of KCD IP, LLC in the United States, or Sears Brands, LLC in other countries

® Marca Registrada / TM Marca de Fábrica de KCD IP, LLC en Estados Unidos, o Sears Brands, LLC in otros países

^{MC} Marque de commerce / ^{MD} Marque déposée de Sears Brands, LLC