

## Owner's Manual

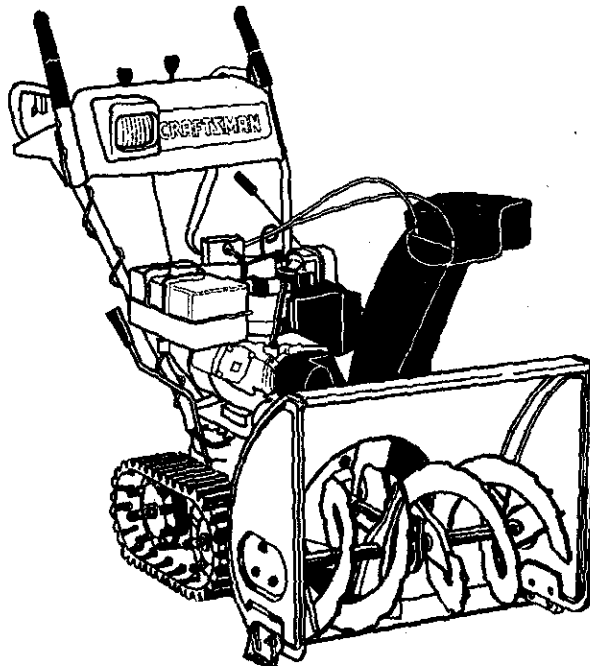

9 Horse Power  
28" Two-Stage Track Drive  
**Snow Thrower**

Model No.  
**247.888550**



**CAUTION:** Before using this product, read this manual and follow all safety rules and operating instructions.

- Safety
- Assembly
- Operation
- Service
- Maintenance
- Español

**Sears, Roebuck And Co., Hoffman Estates, IL 60179, U.S.A.**

Visit our Sears website: [www.sears.com/craftsman](http://www.sears.com/craftsman)

# TABLE OF CONTENTS

Content	Page	Content	Page
Warranty Information .....	2	Service & Adjustment.....	20
Safe Operation Practices .....	3	Off-Season Storage .....	24
Hardware Pack .....	5	Trouble-Shooting .....	25
Assembly .....	6	Parts List.....	26
Operation .....	12	Espanol.....	40
Maintenance .....	17		

# WARRANTY INFORMATION

## Two -Year Warranty on Craftsman Snow Thrower

For two years from the date of purchase, when this Craftsman Snow Thrower is maintained, lubricated and tuned up according to the instructions in the owner's manual, Sears will repair, free of charge, any defect in material and workmanship.

If this Craftsman snow thrower is used for commercial or rental purposes, this warranty applies for only 30 days from the date of purchase.

**This warranty does not cover:**

Expendable items which become worn during normal use, such as skid shoes, shave plate and spark plugs.

Repairs necessary because of operator abuse or negligence, including bent crankshafts and the failure to maintain the equipment according to the instructions contained in the owner's manual.

**WARRANTY SERVICE IS AVAILABLE BY RETURNING THE CRAFTSMAN SNOW THROWER TO THE NEAREST SEARS SERVICE CENTER/DEPARTMENT IN THE UNITED STATES.**

**This warranty applies only while this product is in use in the United States.**

This warranty gives you specific legal rights and you may also have other rights which may vary from state to state.

SEARS, ROEBUCK AND CO., D/817WA, HOFFMAN ESTATES, IL 60179

### PRODUCT SPECIFICATIONS

Horsepower:	9
Engine Oil	SAE 5W30 oil
Fuel Capacity:	1 gallon
Spark Plug:	RJ-19LM
Engine:	143.999005

### MODEL NUMBER

Model Number	<b>247.888550</b>
Serial Number.....	.....
Date of Purchase .....	.....
Record both serial number and date of purchase and keep in a safe place for future reference.	

# SAFE OPERATION PRACTICES



This symbol points out important safety instructions which, if not followed, could endanger the personal safety and/or property of yourself and others. Read and follow all instructions in this manual before attempting to operate your snow thrower. Failure to comply with these instructions may result in personal injury. When you see this symbol—**heed its warning.**



**DANGER:** Your snow thrower was built to be operated according to the rules for safe operation in this manual. As with any type of power equipment, carelessness or error on the part of the operator can result in serious injury. If you violate any of these rules, you may cause serious injury to yourself or others.



This unit is equipped with an internal combustion engine and should not be used on or near any unimproved forest-covered, brush-covered or grass-covered land unless the engine's exhaust system is equipped with a spark arrester meeting applicable local or state laws (if any). If a spark arrester is used, it should be maintained in effective working order by the operator.

In the State of California the above is required by law (Section 4442 of the California Public Resources Code). Other states may have similar laws. Federal laws apply on federal lands. A spark arrester for the muffler is available through your nearest Sears Authorized Service Center (See the REPAIR PARTS section of this manual.)

## TRAINING

- Read this owner's guide carefully in its entirety before attempting to assemble or operate this machine. Be completely familiar with the controls and the proper use of this machine before operating it. Keep this manual in a safe place for future and regular reference and for ordering replacement parts.
- Never allow children under 14 years old to operate a snow thrower. Children 14 years old and over should only operate a snow thrower under close parental supervision. Only persons well acquainted with these rules of safe operation should be allowed to use your snow thrower.
- No one should operate this unit while intoxicated or while taking medication that impairs the senses or reactions.
- Keep the area of operation clear of all persons, especially small children and pets.
- Exercise caution to avoid slipping or falling, especially when operating in reverse.

## PREPARATION

- Thoroughly inspect the area where the equipment is to be used and remove all door mats, sleds, boards, wires and other foreign objects.
- Do not operate equipment without wearing adequate outer garments for winter. Do not wear jewelry, long scarfs or other loose clothing which could become entangled in moving parts. Wear footwear which will improve footing on slippery surfaces.
- Before working with gasoline, extinguish all cigarettes and other sources of ignition. Check the fuel before starting the engine. Gasoline is an extremely flammable fuel. Do not fill the gasoline tank indoors, while the engine is running, or until engine has been allowed to cool at least two minutes. Replace

gasoline cap securely and wipe off any spilled gasoline before starting the engine as it may cause a fire or explosion.

- Use a grounded three wire plug-in for all units with electric drive motors or electric starting motors.
- Adjust collector housing height to clear gravel or crushed rock surface.
- Never attempt to make any adjustments while engine is running (except where specifically recommended by manufacturer).
- Let engine and machine adjust to outdoor temperature before starting to clear snow.
- Always wear safety glasses or eye shields during operation or while performing an adjustment or repair, to protect eyes from foreign objects that may be thrown from the machine in any direction.

## OPERATION

- Do not put hands or feet near or under rotating parts. Keep clear of discharge opening and auger at all times.
- Exercise extreme caution when operating on or crossing gravel drives, walks, or roads. Stay alert for hidden hazards or traffic.
- Do not carry passengers.
- After striking a foreign object, stop the engine, remove wire from the spark plug and thoroughly inspect the snow thrower for any damage. Repair the damage before restarting and operating the snow thrower.
- If the snow thrower starts to vibrate abnormally, stop the engine and check immediately for the cause. Vibration is generally a warning of trouble.
- Stop the engine whenever you leave the operating position, before unclogging the collector/impeller housing or discharge guide and before making any repairs, adjustments, or inspections. Never place your

hand in the discharge or collector openings. Use a stick or wooden broom handle to unclog the discharge opening.

- Take all possible precautions when leaving the unit unattended. Disengage the collector/impeller, stop the engine and remove the key.
- When cleaning, repairing, or inspecting, make certain collector/impeller and all moving parts have stopped. Disconnect spark plug wire and keep away from plug to prevent accidental starting.
- Do not run the engine indoors, except when starting it and/or transporting the snow thrower in or out of building. Open doors before starting the engine in that case. Exhaust fumes are dangerous.
- Do not clear snow across the face of slopes. Exercise extreme caution when changing direction on slopes. Do not attempt to clear steep slopes.
- Never operate the snow thrower without guards, plates or other safety protection devices in place.
- Never operate the snow thrower near glass enclosure, automobiles, window wells, drop off, etc., without proper adjustments of snow thrower discharge angle. Keep children and pets away.
- Do not overload machine capacity by attempting to clear snow at too fast a rate. Never operate the machine at high transport speeds on slippery surfaces. Look behind and use care when backing.
- Never direct discharge at bystanders or allow anyone in front of unit while throwing snow.
- Disengage power to collector/impeller of the snow thrower when transporting it or when the unit is not in use.
- Use only attachments and accessories (such as wheel weights, counter weights, cabs, etc.) approved

by the snow thrower manufacturer.

- Never operate the snow thrower without good visibility or light. Always be sure of your footing and keep a firm hold on the handles. Walk, never run.
- Muffler and engine become hot and can cause severe burn injury. Do not touch the muffler or the engine while starting or operating the snow thrower.

## MAINTENANCE AND STORAGE

- Check shear bolts, engine mounting bolts, etc., at frequent intervals for proper tightness, thus ensuring that the equipment is in safe working condition.
- Never store the machine with fuel in the fuel tank inside a building where ignition sources are present, such as hot water heaters, space heaters, clothes dryers and the like. Allow engine to cool before storing in any enclosure.
- Always refer to owner's guide instructions for important details if the snow thrower is to be stored for an extended period.
- Run machine a few minutes after throwing snow to prevent freeze-up of the collector/impeller.
- Check clutch controls periodically to verify that these engage and disengage properly and readjust if necessary. Refer to Service and Adjustments section page of this owner's guide.

## YOUR RESPONSIBILITY

- Restrict the use of this power machine to persons who read, understand and follow the warnings and instructions in this manual and on the machine.

Following are representations of some of the safety labels on your Craftsman snowthrower. Please follow the instruction on these labels and maintain safety while using or servicing the equipment.

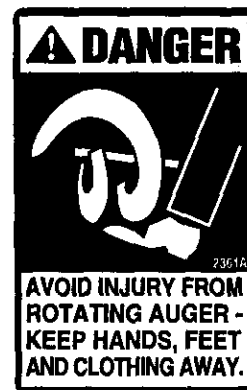

# HARDWARE PACK

Lay the hardware pieces from the hardware pack on top of the figure here and you will have automatically sorted these according to the steps of the assembly procedure described later. (Only one unit of each hardware has been shown per group. The number in parenthesis indicates the total number of the hardware needed in that group.)

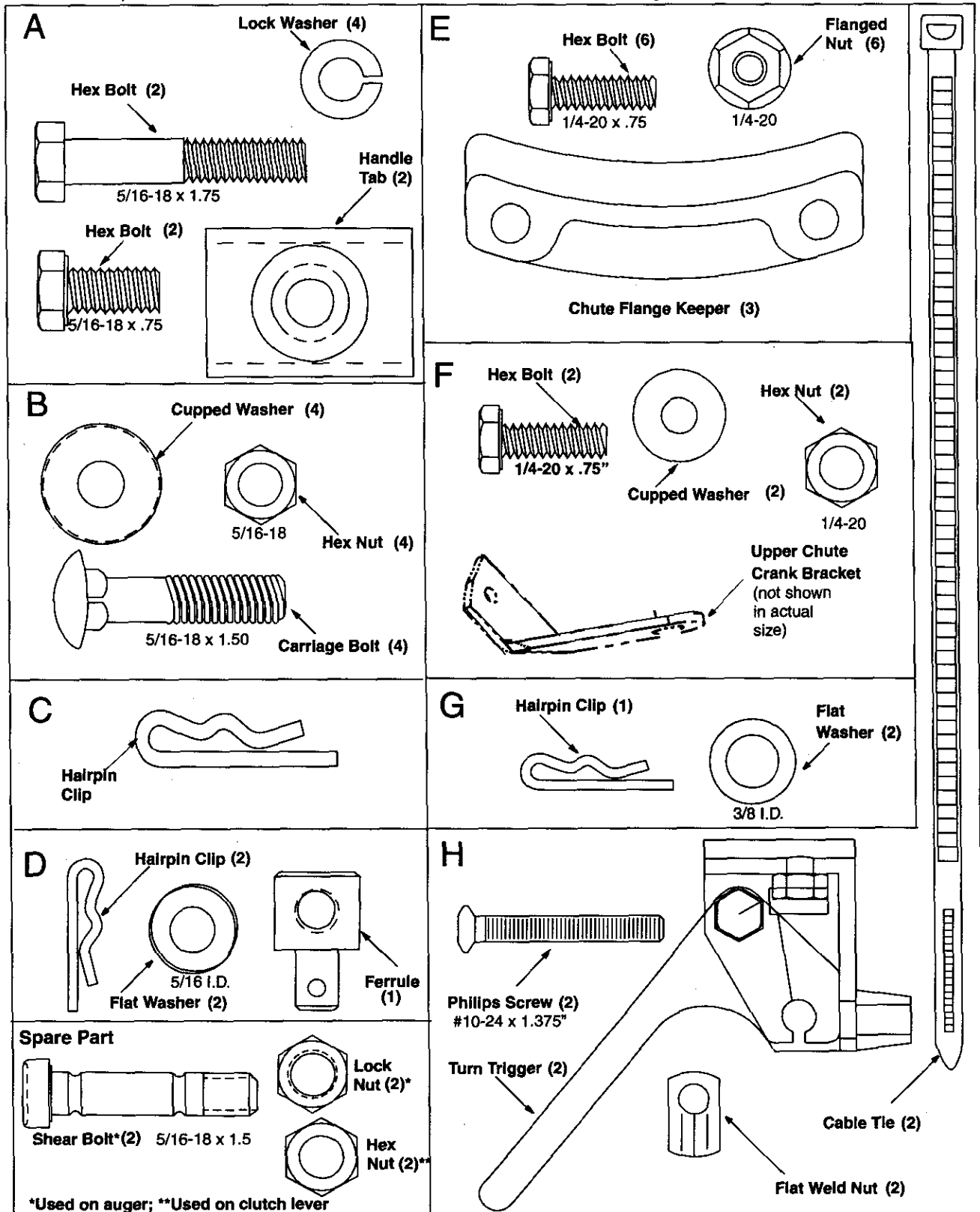

# ASSEMBLY

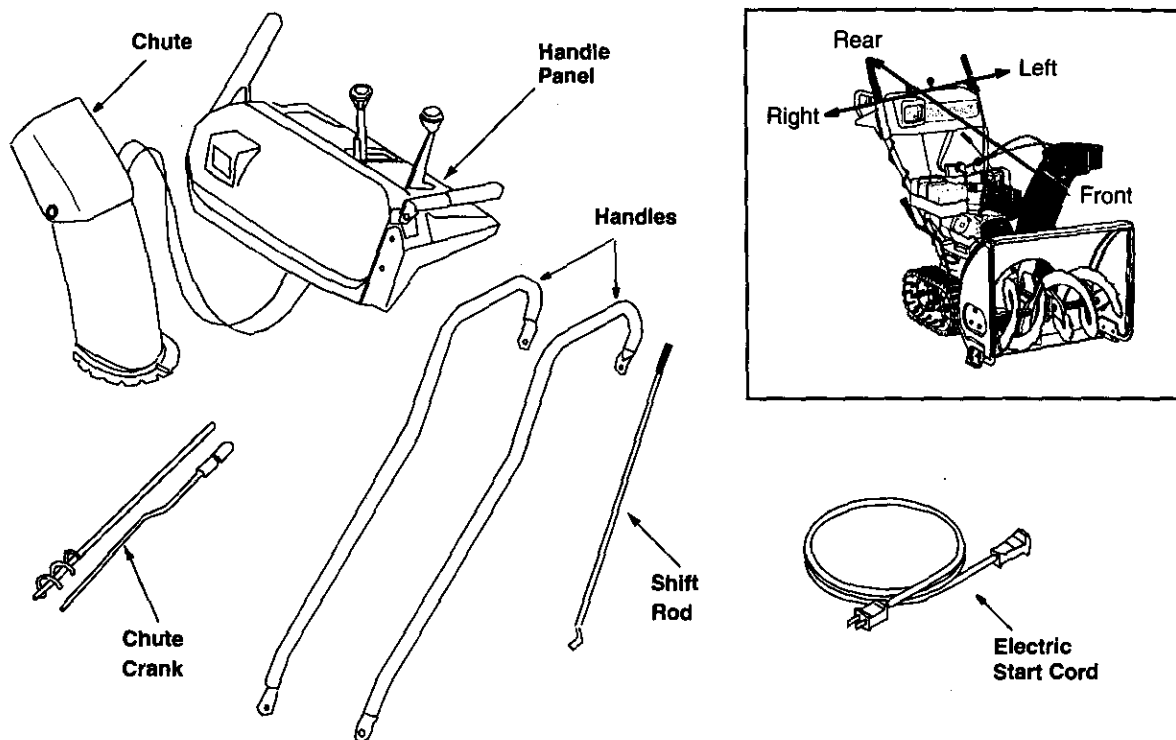

Figure 1

**IMPORTANT:** This unit is shipped with engine oil, but **without gasoline**, in the engine. After assembly, see OPERATION section of this manual for fuel selection and fill-up.

**NOTE:** To determine right and left hand sides of your snow thrower, stand behind the unit in the operator's position. See Figure 1 inset.

Your snow thrower has been assembled at the factory, except the handle and the handle panel, the discharge chute assembly, the chute crank assembly and the shift rod. These parts are shipped loose in the carton.

## Removing From Carton

- Cut the corners of the carton and lay the sides flat on the ground. Remove all packing inserts.
- Remove all loose parts. For a complete list of the loose parts, refer to the following section.
- Move the snow thrower out of the carton.
- Make certain all parts and literature have been removed before discarding the carton.

## Loose Parts

(See Figure 1.)

- a. Handle Panel & Chute Assembly
- b. Right Hand & Left Hand Handles

- c. Electric Start Cord
- d. Two-Piece Chute Crank Assembly
- e. Shift Rod
- f. Hardware Pack

**Assembly Tips:** For easier assembly purposes, remove the chute from the carton and lay it on top of the engine. Do not unwrap the chute till you have installed the handle panel and the clutch cables.

## Tools Required

1. 1/2", 7/16", 3/8" wrenches or a set of adjustable wrenches
2. Set of standard head screw drivers
3. Set of philips head screw drivers
4. Funnel to fill up gasoline



**WARNING:** Make certain the **spark plug wire is disconnected** and moved away from the spark plug before assembling the snow thrower.

## Attaching Handle Assembly

- Stretch out control cables and place on the floor. Place the right handle in position with the flat side against the snow thrower. *You can identify the right handle by the traction drive control label on it and the left handle by the auger clutch control label on it.*

- Secure bottom hole on the handle to the snow thrower using 5/16 x .75" hex bolt and lock washer from the hardware pack (group A on page 5 ). Do not tighten at this time. See Figure 2.

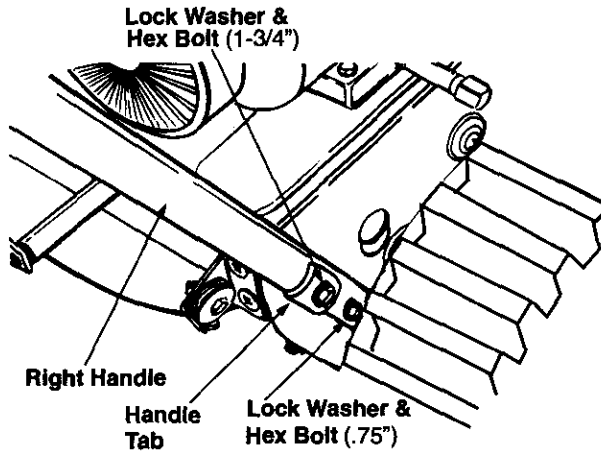

Figure 2

- Place a handle tab, included in the hardware pack (group A ), over the upper hole in handle so that the contour of the handle tab matches that of the handle. See Figure 2.
- Secure handle tab to the snow thrower using hex bolt (5/16 x 1.75" long) and lock washer from the same group in the hardware pack. Do not tighten at this time.
- Attach the left handle in the same manner. Do not tighten at this time.
- Place the handle panel in position between the handles so the ends of the curved part of the handles go through the slots in the handle panel. While placing the handle panel, make sure to route chute and chute cable between the handle and the panel keeping the cable on top of the engine. Align the holes in the handle with the holes on the two sides of the handle panel. See Figure 3.

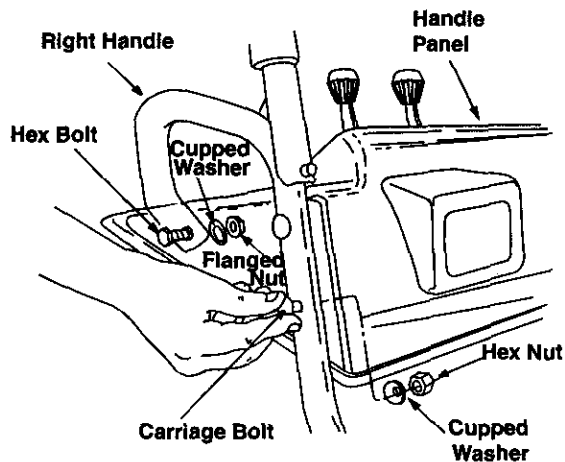

Figure 3

- Attach handle panel to the handle with two carriage bolts, cupped washers (cupped side against the handle panel) and hex nuts on each side. See Figure 3. You will find these fasteners in group B of the hardware pack. Align contour of the carriage bolt head with the handle. Tighten the hardware. Repeat on other side.
- Align the hole on the curved part of the right handle with the corresponding hole on the right side of handle panel making sure that this end of the handle is firmly placed in the slot on the handle panel. See Figure 3.
- Insert a hex bolt, cupped washer and flange nut from Group F of the hardware pack through these holes as shown in Figure 3. Tighten to secure. Do not attach the left side now.

### Attaching Chute

- Place the chute assembly over the chute opening with the chute facing front of the unit.

**NOTE:** Make sure that the chute cables are straightened while assembling the chute.

- Place the chute flange keeper (flat side down) beneath lip of chute assembly as shown in Figure 4. You will find the chute flange keepers in group E of the hardware pack.
- Insert 1/4-20 x .75" hex bolt and flange nut (group E of the hardware pack) up through chute flange keeper and chute assembly as shown in Figure 4. Do not tighten at this time. Rotate chute to install all the flange keepers.

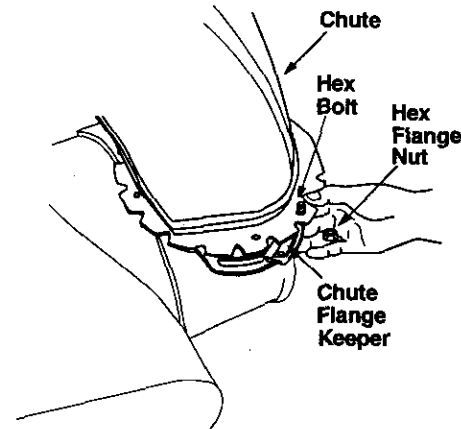

Figure 4

- After assembling all three chute flange keepers, tighten, then back off 1/4 turn to allow easier movement of the chute. Use (2) 7/16" wrenches.

### Attaching Chute Crank

- On the left side of the handle panel, place the upper chute crank bracket on to the inside of the handle panel support. Locate this bracket and associated hardware in group F of hardware pack. See Figure 5.

- Insert hex bolt through the upper chute crank bracket, handle panel support, and upper left handle. Secure the bracket using cupped washer and hex nut. Make sure that the cupped side of the washer is set against the contour of the handle.

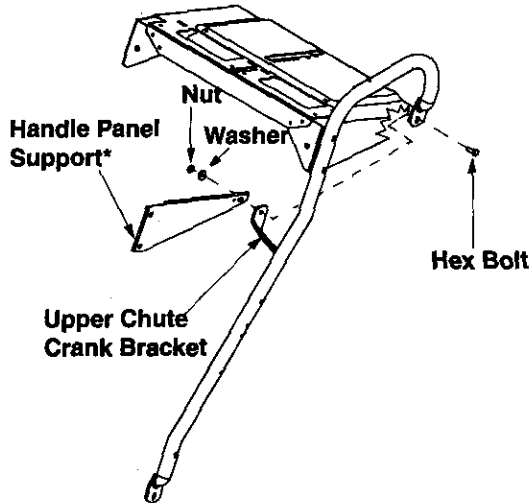

\* This part is already attached inside the handle panel.

**Figure 5**

- You may have to loosen the carriage bolts and hex lock nuts which secure the lower chute crank bracket to the extension on the left side of the chute assembly. See Figure 6.

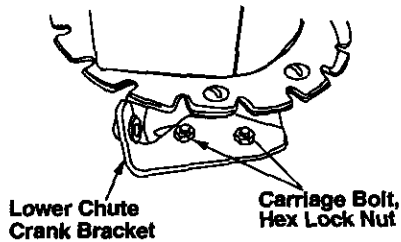

**Figure 6**

- Place one 3/8 ID flat washer (from group G of the hardware pack) on the end of the chute crank, then insert the end of the crank into the eye hole in the plastic bushing in the chute crank bracket. See Figure 7.

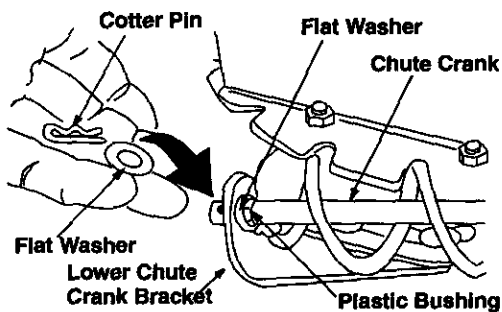

**Figure 7**

- Place the other 3/8 ID flat washer (from the same group of hardware) on the end of the chute crank and insert hairpin clip into eye hole at the end of the chute crank. See Figure 7.
- Slide the upper chute crank through the plastic bushing in the upper chute crank bracket and then into the lower chute crank. See Figure 8. Align the holes on the two pieces of the chute crank, and secure with hairpin clip from group C of the hardware pack.
- Adjust the chute bracket so that the spiral on the chute crank fully engages the teeth on the chute assembly.
- Using a wrench, tighten the hex bolt and the hex nut on the upper chute crank bracket.
- Fully rotate the chute, using the chute crank, to make sure that it moves freely. Tighten the nuts on the lower chute crank bracket securely.

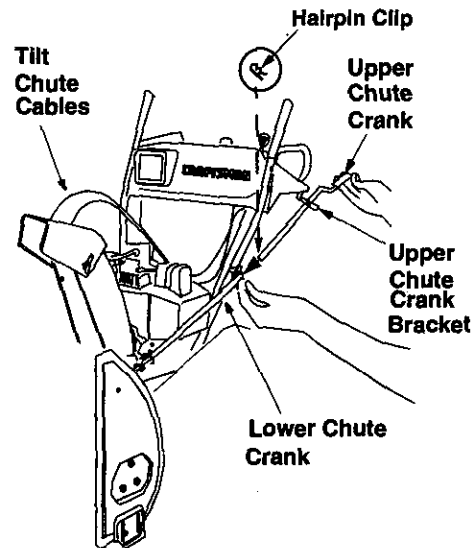

**Figure 8**

- Slip the cables that run from the handle panel to the chute into the cable guide located on top of the engine. See Figure 9.

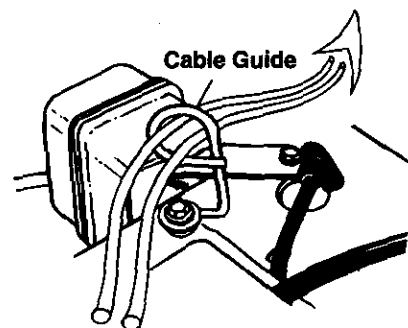

**Figure 9**



- Tighten all loose hardware on the handle assembly in the following order — first the hex bolts at the bottom of the handle, then the carriage bolts and lastly the hex bolts on the rear of the handle panel.

## Attaching Clutch Cables

The clutch control cables are attached to the snow thrower. If the cables are attached to the top of the engine with cable ties, cut the cable ties now. The Z ends of the clutch cables are hooked into the clutch grips on each handle.

- Ensure there is a hex jam nut threaded all the way up the threaded portion of the Z fitting; extras are supplied in the hardware pack. See Figure 10.
- Place the clutch grip in the raised (up) position.

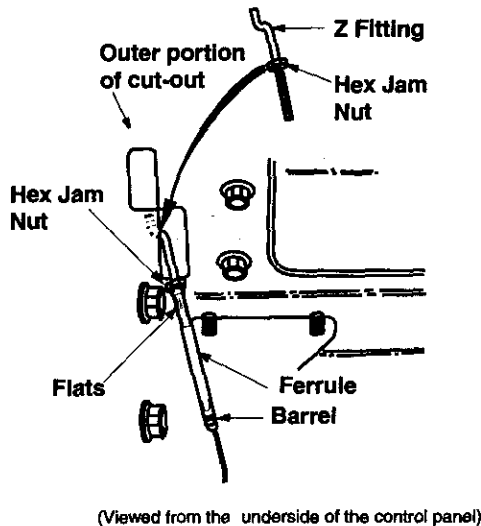

Figure 10

- Swing the left auger up making sure the cable is routed correctly in the cable roller guides located at the lower rear of the unit.
- Hold the end of the cable at the barrel so the ferrule turns freely without twisting the cable. Thread the ferrule on to the Z fitting. You may have to pull on the cable slightly to relieve tension. Keep the ferrule turning *without twisting* the cable.
- You will reach correct adjustment when there is minimal slack in the cable but it is not tight. Hold the flats on the ferrule with pliers and tighten the jam nut against the ferrule.

**CAUTION:** Cables will become loose if you do not tighten the jam nut.



**WARNING:** There must not be any tension on either clutch cable with the drive or auger clutch grip in the disengaged (up) position. These clutches are a safety feature. **Do not override** their function by allowing tension on either cable with the clutches disengaged.

## Attaching Shift Rod

- Place the shift lever in the sixth (6) speed.
- Place the bent end of the shift rod into the hole in the shift arm assembly. See Figure 11. Secure with 5/16 flat washer and hairpin clip from the hardware pack (group D on page 5).
- Start threading the ferrule (included in the same group in the hardware pack) onto the other end of the shift rod. It has to line up with the upper hole in the shift lever (beneath the handle panel). While aligning the ferrule, push down on the shift rod and the shift arm assembly as far as it will go.
- Once the ferrule slides into the hole, turn it counter-clockwise one more full turn and insert it in the hole in the shift lever.

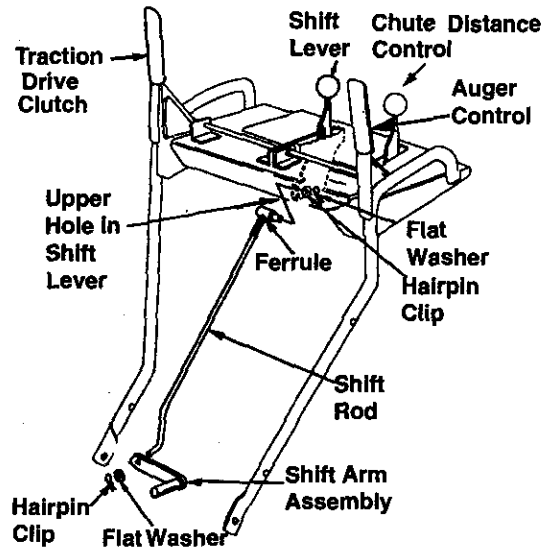

Figure 11

**NOTE:** It may be necessary to pull the shift lever out of the sixth speed position and move it towards the fifth speed position until the ferrule slides into the hole without force.

- Secure the ferrule to the shift lever with another 5/16 flat washer and hairpin clip from group D of the hardware pack. See Figure 11.
- Make certain to check for correct adjustment of the shift rod as instructed in the Adjustment section before operating the snow thrower.

## Attaching Turn Triggers

- Make sure that the right hand trigger cable is routed in front of the traction drive cable.
- Feed the trigger cable up through the outer side of the slot in the handle panel. Do *not* feed the cable through the same side of the slot as the Z fitting.
- Place the cable barrel fitting into the hole in the trigger. You can find the triggers and associated hardware in group H of the hardware pack (on page 5). Pull on the cable and rotate it around the bottom of the trigger, with the inner cable in the slot, until the cable end can be pushed into the trigger housing and snapped tight. See Figure 12.

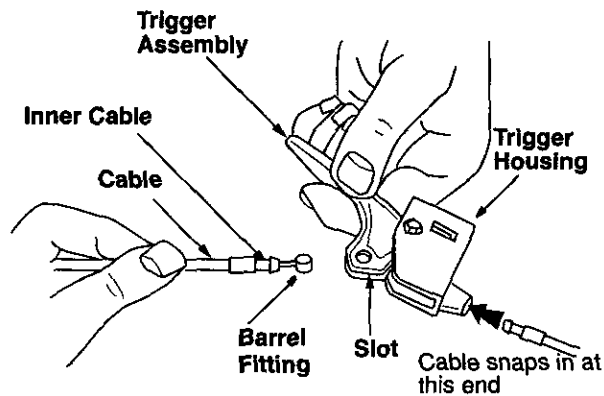

Figure 12

**Note:** When the cable is installed correctly, it should not be possible to pull cable out of the trigger housing.

- Place the right turn trigger in position underneath the right handle. Secure with screw and weld nut from group H of the hardware pack. See Figure 13. You will need a phillips screwdriver for tightening the screw. Repeat on left side.

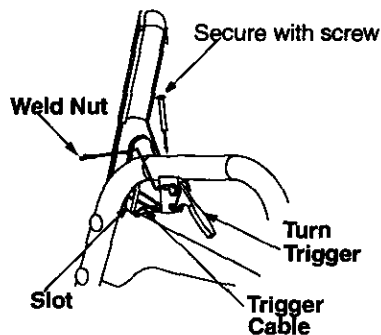

Figure 13

- Secure the right turn trigger cable to the right lower handle, using cable tie provided in the

hardware pack. Make sure to route the cable tie *over the drive cable*. See Figure 14.

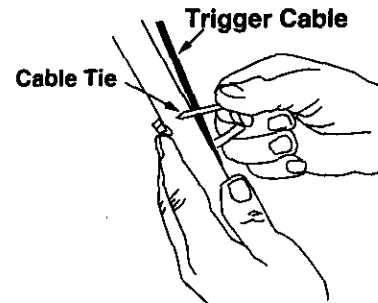

Figure 14

- Secure the left turn trigger cable to the lower handle using the other cable tie. Make sure to route the cable tie *below the auger drive cable* so that when the trigger cable is secured by the cable tie, the auger drive cable is left outside the cable tie. Trim excess ends from each cable tie.

**NOTE:** The right side cable tie must be used to keep cable from coming in contact with the moving shift arm from the transmission.

## Lamp Wiring

- Wrap the wire from the lamp down the right handle. Plug wire into the alternator lead wire under the fuel tank. See Figure 15.

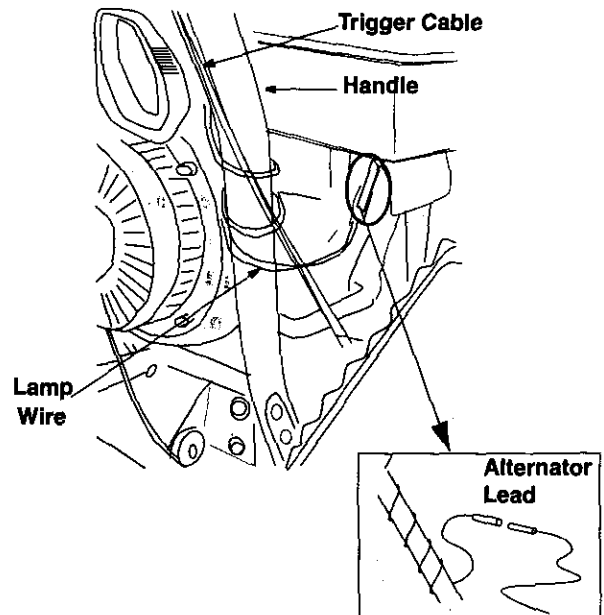

Figure 15

**IMPORTANT:** Assemble your snow thrower, then check the adjustments as instructed and make any final adjustments necessary *before* operating the unit. Failure to follow the instructions may cause damage to the snow thrower.

## Final Adjustments

### Adjusting Auger Control

- To check the adjustment of the auger control, push forward the left hand clutch grip until the rubber bumper is compressed. There should be slack in the clutch cable.
- Release the clutch grip. The cable should be straight. Make certain you can depress the auger control grip against the left handle completely.
- If adjustment is necessary, loosen the hex jam nut and thread the cable in (for less slack) or out (for more slack).
- Recheck the adjustment. Tighten the jam nut against the cable when correct adjustment is reached.

### Adjusting Traction Drive Control

- To check the adjustment of the traction drive control and shift lever, move the weight transfer lever to the transport position (shown in Figure 18 on page 13) and the shift lever all the way forward to sixth (6) position.
- With the traction drive control released, pull the triggers up to the handle and then push the snow thrower forward to check that the tracks turn.
- Squeeze traction drive control against the handle and pull the starter. The tracks should turn.
- Now release the traction drive control and pull the starter again. The unit should not move.
- Before proceeding with adjustment, make sure that the **spark plug is disconnected**.
- If the traction drive control needs adjustment, loosen the jam nut on the traction drive cable and thread the cable one turn. Recheck adjustment and repeat as necessary.
- Tighten the jam nut to secure the cable when correct adjustment is reached.

**NOTE:** Cables are out of adjustment if augers continue to turn when auger clutch is released and/or machine continues to run when drive clutch is released. For more details, refer to the Service and Adjustment section.

### Adjusting Skid Shoe

The space between the shave plate and the ground can be changed by adjusting the skid shoe.

- Return weight transfer lever to normal position before adjusting skid shoes.
- For close snow removal, adjust skid shoes higher to minimize gap between the shave plate and the ground.
- For snow removal from uneven ground like gravel, adjust skid shoes downward to create sufficient clearance between the bottom edge of the shave plate and the ground. See Figure 16.

**NOTE:** It is not recommended that you operate this snow thrower on gravel as loose gravel can be easily picked up and thrown by the auger causing an injury or damage to the snow thrower. However, if you do have to use the snow thrower on gravel, put the weight transfer lever to transport position.

- Adjust skid shoes by loosening the four hex nuts and carriage bolts and moving skid shoes to desired position. Make certain the entire bottom surface of skid shoe is against the ground to avoid uneven wear on the skid shoes. See Figure 16.
- Retighten nuts and bolts securely.

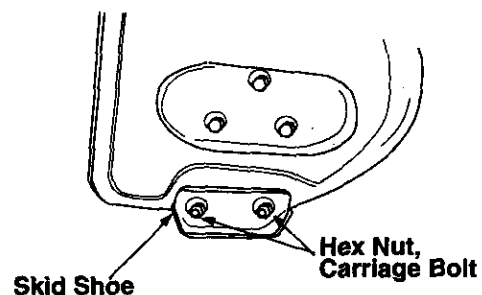

Figure 16

# OPERATION

## Knowing Your Snow Thrower



Read this owner's manual and safety rules before operating your snow thrower. Compare with your snow thrower to familiarize yourself with the location of various controls and adjustments. Save this manual for future reference.

The operation of any snow thrower can result in foreign objects being thrown into the eyes, which can result in severe eye damage. Always **wear safety glasses** for operating the snow thrower, or while performing any adjustments or repairs on it.

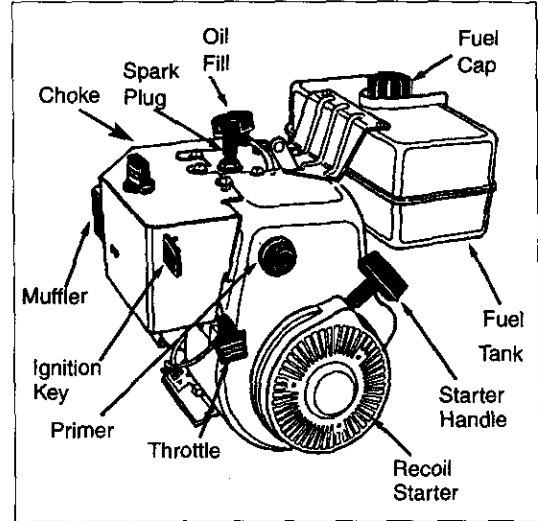
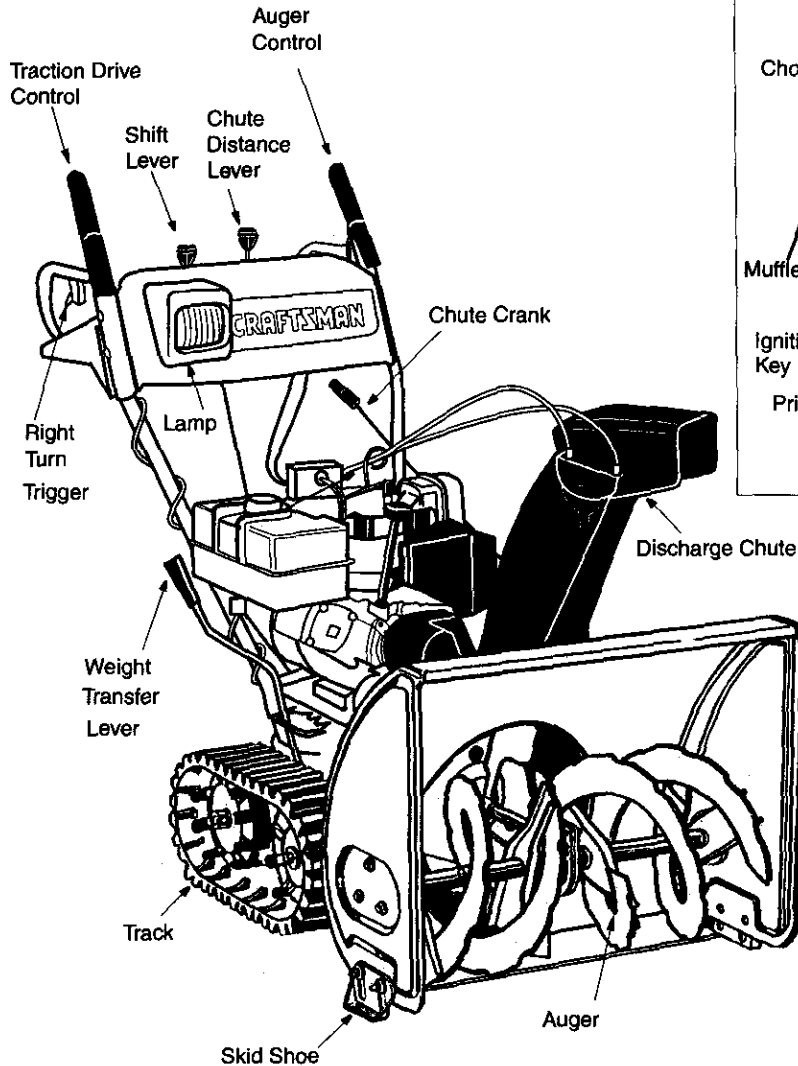

Figure 17

---

### Meets ANSI Safety Standards

Sears snow throwers conform to the safety standards B71.3 of the American National Standards Institute (ANSI).

---

## Operating Controls

(See Figure 17.)

### Chute Crank

The chute crank is located on the left side of the snow thrower. To change the direction in which snow is thrown, turn chute crank as follows:  
turn *clockwise* to discharge to the left;  
turn *counterclockwise* to discharge to the right.

### Chute Distance Control

The distance that snow is thrown can be adjusted by adjusting the angle of the chute assembly. Push the chute distance control lever forward to move the upper chute down and decrease the distance. Pull the lever back toward the rear to move the upper chute up and increase the distance.

### Left And Right Turn Trigger

The left and right turn triggers are located on the underside of the handles and are used to assist in steering your snow thrower. Squeeze the right turn trigger when turning right, squeeze the left turn trigger when turning left. Operate your snow thrower in open areas until you become familiar with these controls.

### Shift Lever

The shift lever is located in the center of the handle panel. It may be moved into one of eight positions:

- a. *Forward*—one of six speeds; position one (1) is the slowest and position six (6) is the fastest.
- b. *Reverse*—two reverse (R) speeds; R<sub>2</sub> is faster.

Use the shift lever to determine ground speed. Do not shift to different speed while the unit is moving.

### Auger Control

The auger control is located on the left handle. Squeeze the auger control against the handle to engage the augers; release to disengage the augers. (Traction drive control must also be released.)

### Traction Drive Control

The traction drive control is located on the right handle. Squeeze the traction drive control to engage the track drive; release to stop.

**This same lever also locks the auger control** so that you can turn the chute crank without interrupting the snow throwing process. If the auger control is engaged with the traction drive control engaged, you can release the auger control (on the left handle) and the augers will remain engaged. Release the traction drive control to stop both the augers and the track drive. (Auger control must also be released.)

### Weight Transfer Lever

The weight transfer lever is located on the right side of the snow thrower and is used to select the position of the housing and the method of track operation. See Figure 18. Move the lever to the right, then forward or backward to one of the three positions.

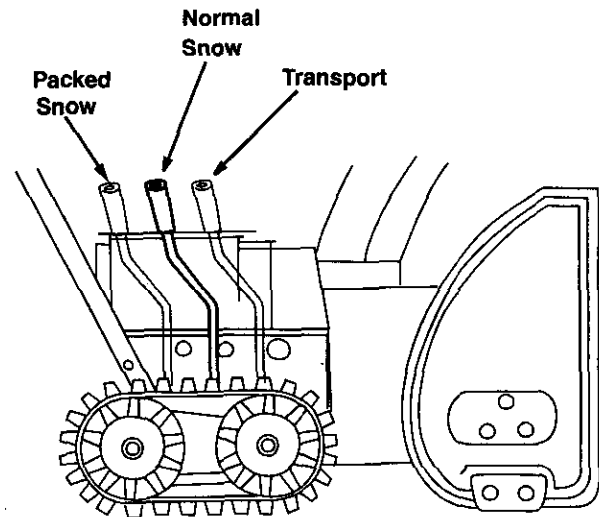

Figure 18

- a. *Transport*—Raises the front end of the snow thrower for easy transport. Using proper caution, this position may also be used on many gravel driveways to clear snow while leaving gravel undisturbed.
- b. *Normal Snow*—Allows the tracks to be suspended independently for continuous ground contact.
- c. *Packed Snow*—Locks the front end of the snow thrower down to the ground for hard-packed or icy snow conditions.

### Throttle Control

The throttle control is located on the engine. It regulates the speed of the engine.

### Safety Ignition Switch

The ignition key must be inserted into the switch for the unit to start. Remove the ignition key when the snow thrower is not in use.

### To Stop The Snow Thrower

- To stop the track, release the traction drive lever of the snow thrower.
- To stop throwing snow, release the auger drive lever and the drive lever if engaged.
- To stop the engine, push the throttle control lever to OFF and pull out the ignition key. Do not turn key.

## Before Starting Engine

### Fill Gas



**WARNING:** Gasoline is flammable and caution must be used when handling or storing it.

Do not fill fuel tank while the snow thrower is running, when it is hot or when it is in an enclosed area.

Keep your snow thrower away from any open flame or an electrical spark and do not smoke while filling the fuel tank.

Never fill the fuel tank completely. Fill the tank to within 1/4"-1/2" from the top to provide space for expansion of fuel.

Always fill the fuel tank outdoors and use a funnel or spout to prevent spilling.

Make sure to wipe off any spilled fuel before starting the engine.

- Store gasoline in a clean, approved container and keep the cap in place on the container.
- Make sure that the container from which you pour the gasoline is clean and free from rust or other foreign particles.
- Fill fuel tank with clean, fresh, unleaded grade automotive gasoline.
- At the end of the job, empty the fuel tank if the snow thrower is not going to be used for 30 days or longer. See storage instructions on page 24 of this manual.

**CAUTION:** Experience indicates that alcohol blended fuels (called gasohol) or those using ethanol or methanol can attract moisture which leads to separation and formation of acids during storage.

Acidic gas can damage the fuel system of an engine while in storage.

To avoid engine problems, the fuel system should be emptied before storage for 30 days or longer. Drain the gas tank, start the engine and let it run until the fuel lines and carburetor are empty. Use fresh fuel next season. See storage instructions for additional information.

Never use engine or carburetor cleaner products in the fuel tank or permanent damage may occur.

## To Start Engine



**WARNING:** Be sure no one other than the operator is standing near the snow thrower while starting or operating. Do not operate this snow thrower unless the discharge chute assembly has been properly installed and is secured.

### A. Electric Starter

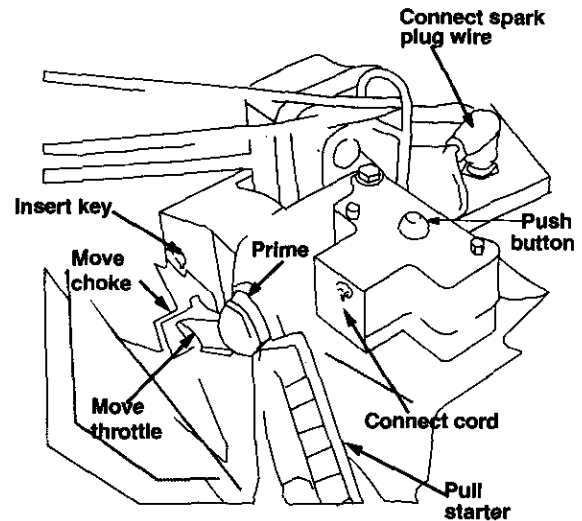

Figure 19

For location of all the engine controls referred to in this section, see Figure 19.

Before starting, make sure that the engine has sufficient oil. The snow thrower engine is equipped with a 120 volt A.C. electric starter and recoil starter. The electric starter is equipped with a three-wire power cord and plug and is designed to operate on 120 volt AC household current. Follow all instructions carefully.



### Starting Instructions at a glance

Snow Thrower	Spark Plug wire	Drive Levers	Throttle control	Ignition Key	Choke	Power Cord	Primer	Starter	After starting
Electric Starter	Connect	Release	Move to FAST	Push to snap in	Move to FULL	Connect to source	—	Push button	1. Release button 2. Move Choke to Off 3. Disconnect cord
Recoil Starter	Connect	Release	Move to FAST	Push to snap in	Move to FULL	—	Prime	Pull handle	1. Release handle 2. Move Choke to Off.

## Cold Start

**NOTE:** If the unit shows any sign of motion (drive or augers) with the clutch grips disengaged, shut the engine off immediately. Readjust as instructed in the "Final Adjustments" section on page 11.

**WARNING:** The electric starter must be properly grounded at all times to avoid possibility of electric shock which may injure the operator.

- Determine whether your house wiring is a three-wire grounded system. Ask a licensed electrician if you are not certain.



**WARNING:** If your house wiring system is not a three-wire grounded system, do not use this electric starter under any conditions.

- If your house wiring system is grounded and a three-hole receptacle is not available at the point the snow thrower starter will normally be used, one should be installed by a licensed electrician.
- When connecting the power cord, always connect cord to starter on engine first, then the other end into a three-hole grounded receptacle.
- When disconnecting the power cord, always unplug the end from the three-hole, grounded receptacle first.
- **Attach** spark plug wire to spark plug.
- Make sure that the auger drive and the traction drive levers are in the disengaged **RELEASED** position.
- Move throttle control lever to **FAST** position.
- Remove the keys from the plastic bag. Push key into the ignition slot. Make sure it snaps into place. *Do not turn key.* Save the second key.
- Rotate the choke knob to **FULL** choke position.
- Connect power cord to switch box on engine.
- Plug the other end of the power cord into a three-hole, grounded 120 volt A.C. receptacle.



**WARNING:** Do not use primer while starting the engine with an electric starter.

- Push down on the starter button until the engine starts. Do not crank for more than 10 seconds at a time. This electric starter is thermally protected. If overheated, it will stop automatically and can be restarted only when it has cooled to a safe temperature (a wait of about 5 to 10 minutes is required).
- When the engine starts, release the starter button and slowly rotate the choke to **OFF** position. If the engine falters, rotate the choke to **FULL** and then gradually to **OFF**.
- Disconnect the power cord from the receptacle first and then from the switch box on the engine.
- Allow the engine to warm up for a few minutes because the engine will not develop full power until it reaches operating temperature.

- Operate the engine at full throttle (**FAST**) when throwing snow.

## Warm Start

- If restarting a warm engine after a shut down, rotate choke to **OFF** instead of **FULL** and press the starter button.

## B. Recoil Starter

Make sure that the engine has sufficient oil and the auger drive and the traction drive levers are released.

- Move throttle control to **FAST** position.
- Push key into the ignition slot so that it snaps into place. Do not turn key. Remove plastic bag and keep the second key in a safe place.
- Rotate choke control to **FULL** choke position.
- Push the primer button while covering the vent hole. Remove your finger from the primer between primes. Do not prime if temperature is above 50° F; prime two times between 50° F and 15° F; and prime four times below 15° F.
- Pull the starter handle rapidly. Do not allow the handle to snap back, but allow it to rewind slowly while keeping a firm hold on the starter handle.
- As the engine warms up and begins to operate evenly, rotate the choke knob slowly to **OFF** position. If the engine falters, return to **FULL** choke, then slowly move to **OFF** choke position.
- Allow the engine to warm up for a few minutes because the engine will not develop full power until it reaches operating temperature.
- Operate the engine at full throttle (**FAST**) when throwing snow.

## Warm Start

- If restarting a warm engine after a temporary shut down, rotate choke to **OFF** instead of **FULL** and do *not* prime. Press the starter button.

## Frozen Recoil Starter

If the starter is frozen and will not turn the engine, proceed as follows:

- Pull as much rope out of the starter as possible.
- Release the starter handle and let it snap back against the starter.
- If the engine still fails to start, repeat the first two steps. If continued attempts do not free starter, follow the electric starter procedures to start.
- Avoid possible freezing of recoil starter and the engine controls.

## Operating Snow Thrower

### To Engage Drive

- With the engine running near top speed, move shift lever to one of six **FORWARD** positions or two **REVERSE** positions. Select a speed appropriate for the snow conditions that exist.

- Use slower speeds until you are familiar with the operation of the snow thrower.
- Squeeze the traction drive clutch grip against the right handle and the snow thrower will move. Release it and the drive motion will stop.

### To Engage Augers

- To engage augers and start snow throwing, squeeze the left hand auger clutch grip against the left handle. Release to stop augers.
- While the auger control is engaged, squeeze the traction drive control to move, release to stop. **Do not** shift speeds while the drive is engaged.

**NOTE:** This same lever also locks the auger control so you can turn the chute crank without interrupting the snow throwing process.

- Release the auger control; the interlock mechanism should keep the auger control engaged until the traction drive control is released.
- Release the traction drive control to stop both the augers and the track drive.



**WARNING:** To stop the auger, both levers must be released.

### To Throw Snow

**CAUTION:** Check the area to be cleared for foreign objects. Remove, if any.

- Move weight transfer lever to the right, then backward or forward to the desired position.
- Start the engine following Starting Instructions.
- Rotate the discharge chute to the desired direction, away from bystanders and/or buildings. Move the chute distance control forward or backward to adjust the distance the snow is to be thrown.
- Select the speed according to the snow condition.

**CAUTION:** Never move the shift lever without first releasing the drive clutch.

- Engage the auger control and traction drive control levers following the preceding instructions.
- The interlock feature will allow you to remove your left hand from the auger control lever.
- When clearing the first pass through the snow, control the traction speed of the snow thrower according to the depth and condition of snow.
- To turn the unit left, squeeze left trigger; to turn right, squeeze right trigger.
- On each succeeding pass, readjust the chute deflector to the desired position and slightly overlap the previously cleared path.

- After the area is cleared, stop the snow thrower following instructions given below.

### Operating Tips

**NOTE:** Allow the engine to warm up for a few minutes as the engine will not develop full power until it reaches operating temperature.



**Warning:** The temperature of muffler and surrounding areas may exceed 150° F. Avoid these areas.

- For most efficient snow removal, remove snow immediately after it falls.
- Discharge snow downwind whenever possible. Slightly overlap each previous swath.
- Set the skid shoes 1/4" below the scraper bar for normal usage. The skid shoes may be adjusted upward for hard-packed snow. Adjust skid shoes downward when using on gravel or crushed rock.
- Clean the snow thrower thoroughly after each use.

### Before Stopping

- Run engine for a few minutes to help dry off any moisture on engine.
- To avoid possible freeze-up of the starter, follow these steps:

#### Recoil Starter

- With the engine running, pull the starter rope with a rapid, continuous full arm stroke three or four times.

#### Electric Starter

- Connect power cord to switch box, then to 120 Volt AC receptacle.
- While the engine is running, push the starter button and spin the starter for several seconds.
- Disconnect power cord from the receptacle first, then from the snow thrower.

**NOTE:** The unusual sound from pulling the starter rope in the case of the recoil starter, or from spinning the starter in the case of the electric starter, will not harm the engine.

### To Stop The Snow Thrower

- To stop the track, release the traction drive lever on the snow thrower.
- To stop throwing snow, release auger drive lever and drive lever, if engaged.
- To stop the engine, push throttle control lever to OFF and pull out the ignition key. *Do not turn key.*



# MAINTENANCE

## General Recommendations

- Always observe safety rules when performing any maintenance.
- The warranty on this snow thrower does not cover items that have been subjected to operator abuse or negligence. To receive full value from the warranty, operator must maintain the snow thrower as instructed in this manual.
- Some adjustments will have to be made periodically to maintain your unit properly.

- All adjustments in the Service and Adjustments section of this manual should be checked at least once each season.
- Follow the maintenance schedule given below.
- Periodically check all fasteners and make sure these are tight.



**WARNING:** Always stop the engine and **disconnect** the spark plug wire before performing any maintenance or adjustments.

## Customer Responsibilities

MAINTENANCE SCHEDULE		Before each Use	After each use	First two hours	Every 25 hours	Every 50 hours	Before storage	SERVICE DATES*										
<b>PRODUCT</b>	Lubricate pivot points			✓		✓												
	Clean snow thrower	✓				✓												
	Clean shave plate			✓														
	Clean skid shoes			✓														
	Check V-belts					✓												
	Check friction wheel rubber				✓													
<b>ENGINE</b>	Check engine oil	✓																
	Change engine oil			✓	✓													
	Check spark plug					✓	✓											
	Check muffler					✓												
	Empty fuel system						✓											

\* Fill in dates as you complete regular service

✓ Check; service if needed

## Lubrication

For a view of the lubrication points on the snow thrower, see Figure 20.

### Sprocket Shaft

- Lubricate the sprocket shaft with grease at least once a season or after every 25 hours of operation.

**IMPORTANT:** Keep all grease and oil off of the friction wheel and the drive plate.

### Shifting Mechanism

- Lubricate the shifting mechanism and pivot points on the shift rod with engine oil at least once a season or after every 25 hours of operation.

### Traction Drive Control

- Lubricate cams on the ends of the control rods which interlock the traction drive and auger controls at least once a season or every 25 hours of operation with grease. The cams can be accessed beneath the handle panel.

### Gear Case

- The gear case is lubricated with grease at the factory and does not require checking. If disassembled for any reason, lubricate with two ounces of Shell Alvania grease.

## Bearings

- Once a season lubricate the auger bearings and the bearings on the side of the frame with light oil. See lubrication chart below.

## Check V-belts

Follow instructions below to check the condition of the drive belts every 50 hours of operation.

- Remove the plastic belt cover on the front of the engine by removing two self-tapping screws.
- Visually inspect for frayed, cracked, or excessively worn out belts.

## Check Friction Wheel

Follow the instructions below to check the condition of the friction wheel rubber every 25 hours of operation.

- Remove the four self-tapping screws from the frame cover underneath the snow thrower.
- Visually inspect the friction wheel rubber for excessive wear, cracks, or loose fit on the friction wheel drive hub.
- Also engage traction drive control and check if the friction wheel is making contact with the friction plate.
- If it does not make contact, adjust the traction drive cable following adjustment instructions. Recheck the friction wheel.
- Replace friction wheel rubber if necessary. Refer to instructions on page 22.

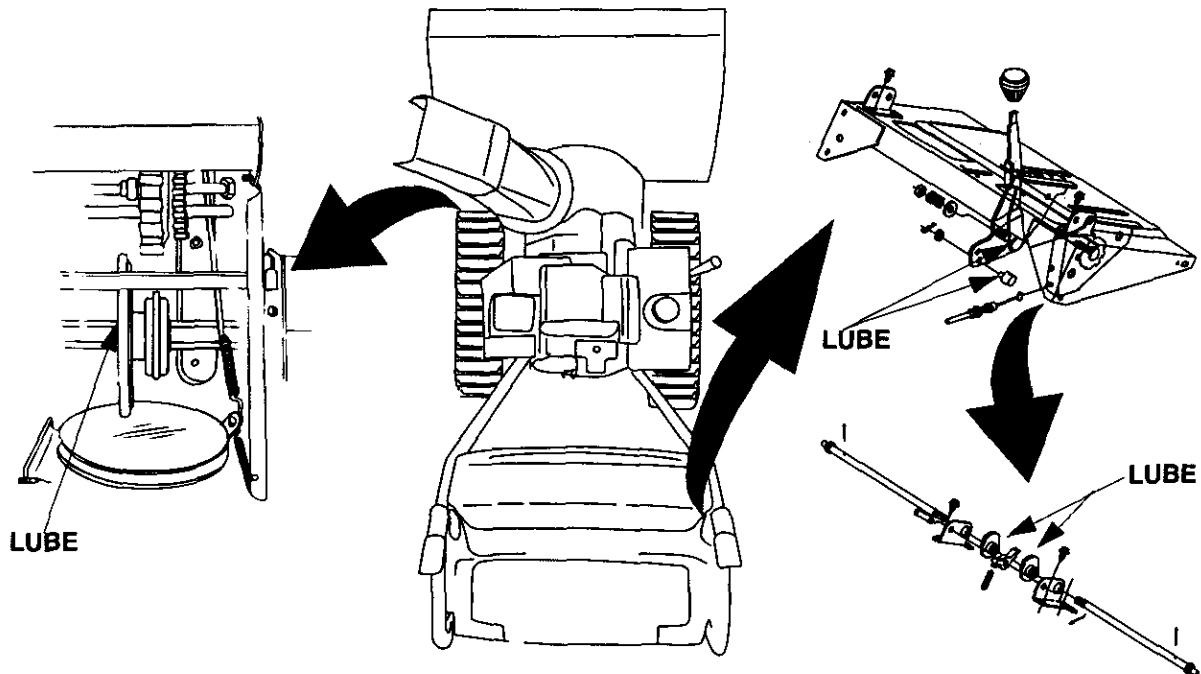
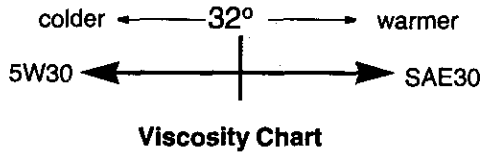

Figure 20: Lubrication Chart

## Engine Maintenance

### Engine Oil

Only use high quality detergent oil rated with API service classification SF, SG or SH. Select the oil's SAE viscosity grade according to the expected operating temperature.



**NOTE:** Although multi-viscosity oils (5W30, 10W30 etc.) improve starting in cold weather, these multi-viscosity oils will result in increased oil consumption when used above 32°F. Check your snow thrower's engine oil level more frequently to avoid possible engine damage from running low on oil.

Refer to the viscosity chart for proper selection of engine oil.

### Checking Oil Level

**IMPORTANT:** Before operating the snow thrower, check the oil level.

- With engine on level ground, the oil must be to FULL mark on dipstick.
- Stop engine and wait several minutes before checking oil level. Remove oil fill cap and dipstick.
- Wipe dipstick clean, insert it into oil fill hole and tighten securely.
- Remove dipstick and check. If oil is not up to the FULL mark on dipstick, add 5W30 oil.

### Changing Oil

Change engine oil after the first two hours of operation and every 25 hours thereafter. In order to do that you will have to first drain the spent engine oil from the engine and then refill with fresh oil.

- Drain oil while engine is warm. Remove oil drain cap located at the bottom of the recoil starter of the engine. Catch oil in a suitable container.
- When engine is drained of all oil, replace drain plug securely.
- Remove the dipstick from the oil fill tube. For location of the oil fill tube, see Figure 17 inset. Pour fresh oil slowly through the tube. Replace dipstick.
- Check and make sure that the oil level is up to the FULL mark on the dipstick.



**WARNING:** Temperature of muffler and nearby areas may exceed 150° F (65°C). Avoid these areas.

### Spark Plug

- Clean area around the spark plug base.
- Remove and inspect the spark plug.
- Replace the spark plug if electrodes are pitted, burned, or the porcelain is cracked. See Figure 21.
- Clean the spark plug and reset the gap to 0.030" at least once a season or every 50 hours of operation. See Figure 21.
- Spark plug replacement is recommended at the start of each season. Refer to engine parts list for correct spark plug type.

**NOTE:** Do not sandblast spark plug. Spark plug should be cleaned by scraping or wire brushing and washing with a commercial solvent.

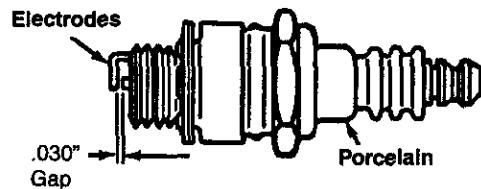

Figure 21

# SERVICE & ADJUSTMENTS



**WARNING:** Always stop the engine, disconnect spark plug wire and move it away from the spark plug before performing any adjustments or repairs.

Never attempt to clean the chute or make any adjustments while the engine is running.

## Adjustments

### Traction Drive Control

Refer to the Final Adjustment section of the Set-Up Instructions to adjust the traction drive control. If you are not sure of proper adjustment, check as follows.

- Drain the gasoline or place plastic film under the gas cap if the snow thrower has already been operated.
- Tip the snow thrower forward and remove the four self-tapping screws that hold the frame cover underneath the snow thrower.
- With the traction drive control *released*, make sure that there is clearance between the friction wheel and the friction plate in all positions of the shift lever. See Figure 22.

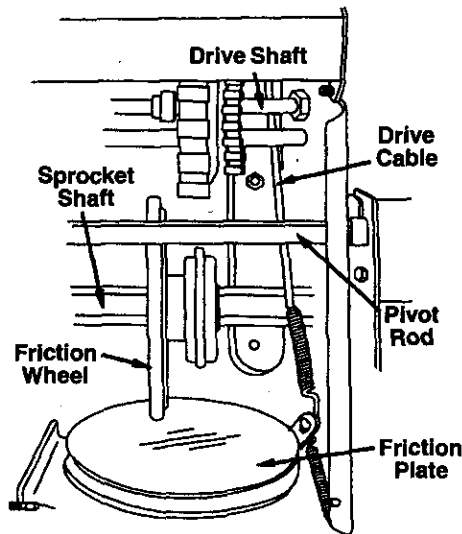

Figure 22

- With the traction drive control *engaged*, make sure that the friction wheel is making contact with the friction plate. Also make sure that the overtravel spring is stretched.
- If adjustment is necessary, loosen the jam nut on the traction drive cable and thread the cable in or out as necessary.
- Tighten the jam nut to secure the cable when correct adjustment is reached. Reassemble the frame cover.

**NOTE:** If you placed plastic under the gas cap, be certain to remove it.

### Augers

The augers are secured to the spiral shaft with two shear bolts and hex lock nuts. If you hit a foreign object or ice jam, the snow thrower is designed so that the bolts will shear.

- If the augers will not turn, check to see if the bolts have sheared. Replace if necessary. See Figure 23. Two replacement shear bolts and hex lock nuts have been provided in Group D of the hardware pack which is illustrated on page 5.

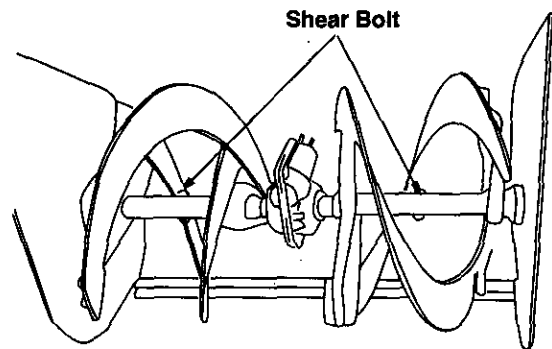

Figure 23

### Auger Clutch

To adjust the auger clutch, refer to Final Adjustment section of Assembly Instructions.

### Chute Assembly

The distance snow is thrown can be adjusted by adjusting the angle of the chute assembly.

### Skid Shoe

The space between the shave plate and the ground can be adjusted by adjusting the skid shoe. Refer to page 11 of this manual.

### Shift Rod

To adjust the shift rod, proceed as follows.

- Remove the hairpin clip and flat washer from the ferrule underneath the shift panel. Remove the ferrule from the hole in the shift lever.
- Place the shift lever on the handle panel in the sixth (6) speed position (all the way forward).
- Push down on the shift rod (and shift arm assembly) as far as it will go. Hold it in this position. See Figure 24.
- Thread the ferrule up or down the shift rod as necessary until the ferrule lines up with the upper hole in the shift lever.

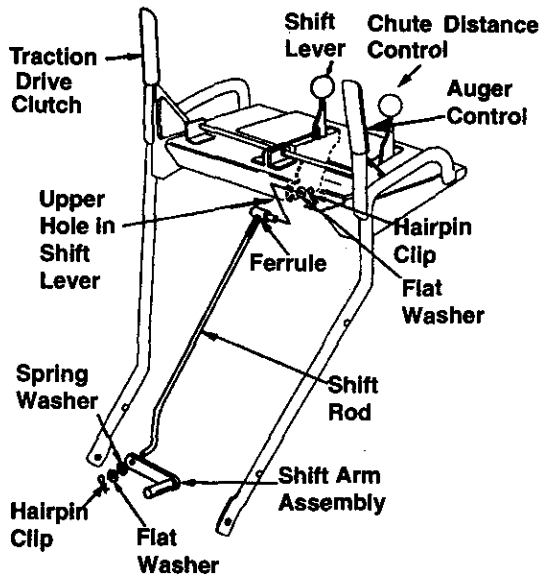

Figure 24

- Insert the ferrule into the upper hole in the shift lever from the right side when adjustment is correct. Secure with the flat washer and the hairpin clip that you had earlier removed. See Figure 24.
- Check for correct adjustment of the traction drive control as instructed in the Final Adjustment section.

## Service

### Shave Plate And Skid Shoes

The shave plate and skid shoes on the bottom of the snow thrower are subject to wear. They should be checked periodically and replaced when necessary.

- To remove skid shoes, remove the two carriage bolts, belleville washers and hex nuts (on each side) which attach them to the snow thrower.
- Reassemble new skid shoes with the hardware earlier removed. Make sure to insert the cupped side of the washer against the skid shoe so that the skid shoe is adjusted to be level.
- To remove shave plate, remove the carriage bolts, belleville washers and hex nuts which attach it to the snow thrower housing. Reassemble new shave plate, making sure heads of the carriage bolts are to the inside of the housing. Tighten securely.

### Belt Removal and Replacement



**WARNING:** Disconnect the spark plug wire from the spark plug and ground it.

### Auger Drive Belts

- Disconnect the chute crank at the chute assembly by removing the cotter pin and the flat washer.
- Remove the plastic belt cover on the front of the engine by removing two self-tapping screws. See Figure 25.

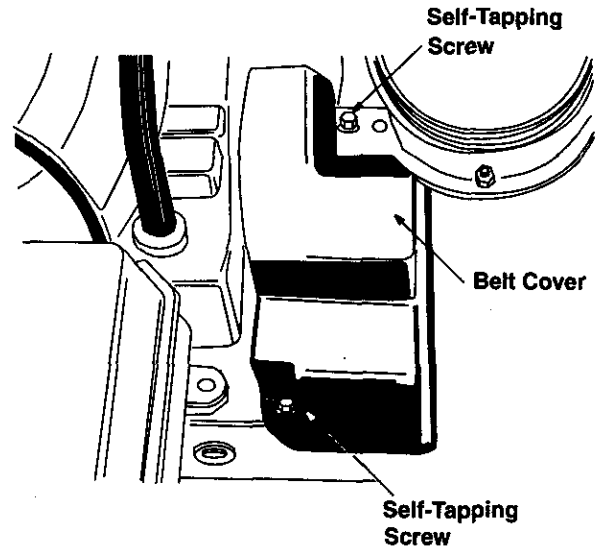

Figure 25

- Unthread the bottom of the auger cable from the top of the cable, leaving the hex nut in place.
- Remove the six lock washers and hex nuts which attach the auger housing assembly to the frame. See Figure 26. (Only two pairs of lock washers and hex nuts are shown in the figure.)

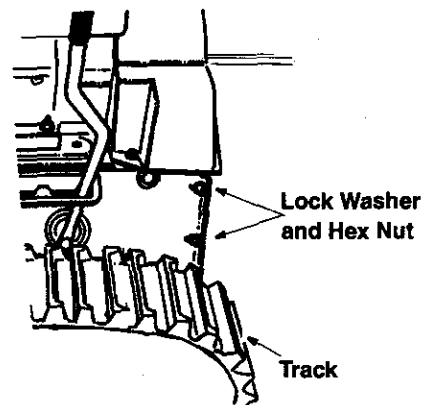
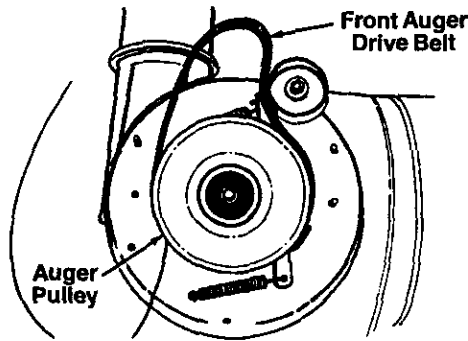

Figure 26

- Separate the housing from the frame assembly by standing in the operating position and lifting up on the handles. The frame and housing will separate and the rear auger drive belt will come off the pulleys.



**Figure 27**

- To remove the front auger drive belt, push the idler pulley to the left and lift front auger drive belt from the front auger pulley. See Figure 27. Replace both auger drive belts by following the preceding instructions.

**NOTE:** When reassembling the two halves of the unit, make sure that the auger drive cable is routed through the cable roller guide.

**Drive Belt**

- Remove the plastic belt cover on the front of the engine by removing the two self-tapping screws. See Figure 25.
- Drain the gasoline from the snow thrower, or place a piece of plastic under the gas cap.
- Tip the snow thrower up and forward so that it rests on the auger housing.
- Remove four self-tapping screws from the frame cover underneath the snow thrower.
- Pulling the idler pulley upward, roll the belt off the idler pulley and the engine pulley and lift belt off friction wheel disc. See Figure 28.

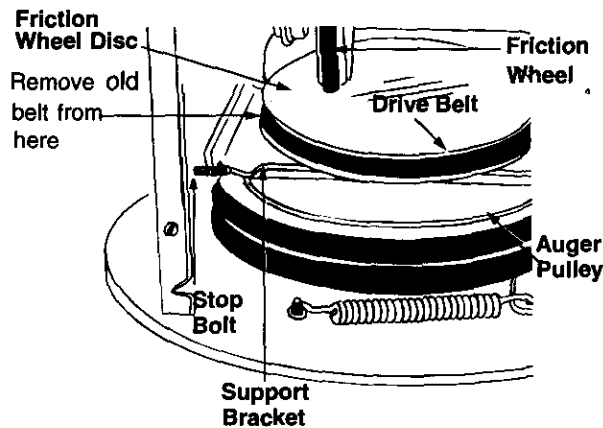

**Figure 28**

- Back out the stop bolt until the support bracket drops on the auger pulley. See Figure 28.
- Slip belt between friction wheel and friction disc plate and remove the belt. See Figure 28.
- Reassemble with new drive belt.

**NOTE:** The support bracket must rest on the stop bolt after the new belt has been assembled. See Figure 28.

**Friction Wheel Rubber**

The rubber on the friction wheel is subject to wear and should be checked after the first 25 hours of operation and periodically thereafter. Replace the friction wheel rubber if any signs of wear or cracking are found.

- Drain the gasoline from the snow thrower, or place a piece of plastic under the gas cap.
- Tip the snow thrower up and forward, so that it rests on the housing.
- Remove four screws from the frame cover underneath the snow thrower (Figure 25).
- Using a 7/8" wrench to hold the shaft, loosen, but do not completely remove, the hex bolt and bell washer from the left end of the shaft. See Figure 29.

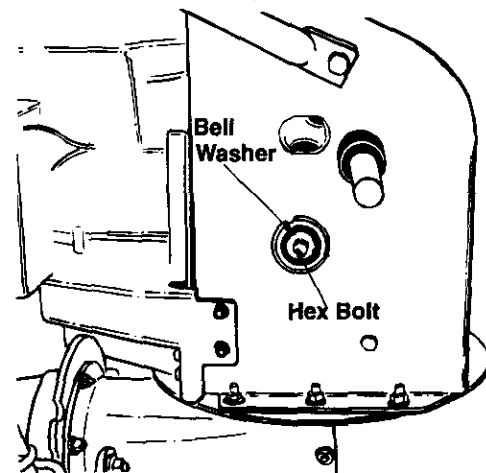

**Figure 29**

- Move the weight transfer lever to the packed snow position. Refer to Figure 18.
- Lightly tap the head of the bolt to dislodge the ball bearing from the right side of the frame; then remove the hex bolt and the bell washer from left end of the shaft.
- Sliding the shaft to the right, remove the spacer, the sprocket and the friction wheel assembly from the shaft. See Figure 30.
- Remove the six screws from the friction wheel assembly (three from each side). Remove the friction wheel rubber from between the friction wheel plate.

- Reassemble the new friction wheel rubber to the friction wheel assembly tightening the six screws in rotation and with equal force.
- Position the friction wheel assembly up onto the pin of the shift rod assembly and slide the shaft through the friction wheel. See Figure 30.
- Slide the shaft into the hex I.D. of the sprocket, the spacer and the left ball bearing and secure with the bell washer and hex bolt.

## Carburetor



**WARNING:** If any adjustments are made to the engine while the engine is running (e.g. carburetor), **keep clear** of all moving parts. Be careful of heated surfaces and muffler.

If you think the carburetor needs to be adjusted, see your nearest authorized Tecumseh Service Outlet.

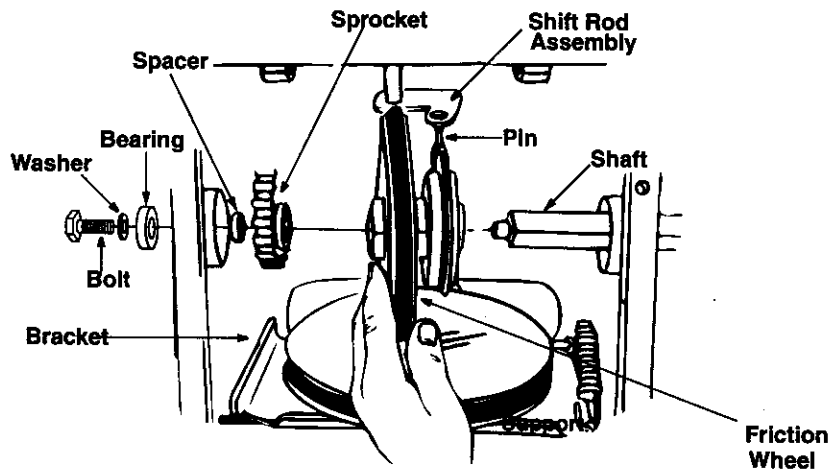

Figure 30

# OFF-SEASON STORAGE

If your snow thrower is left unused for 30 days or longer, it needs to be prepared for storage. Also, at the end of the snow season, you should follow the same set of instructions and store the snow thrower properly for the off-season. Proper storage ensures longer life of the snow thrower.

## Preparing Engine



**WARNING:** Never store snow thrower with fuel in tank indoors or in poorly ventilated areas, where fuel fumes may reach an open flame, spark or pilot light as on a furnace, water heater, clothes dryer or gas appliance.

It is important to prevent gum deposits from forming in essential fuel system parts of the engine such as the carburetor, fuel filter, fuel hose or tank during storage.

Also experience indicates that alcohol blended fuels (called gasohol or using ethanol or methanol) can attract moisture which leads to separation and formation of acids during storage. Acidic gas can damage the fuel system of an engine while in storage.

To avoid engine problems, the fuel system *should be emptied* before storage for 30 days or longer. Follow these instructions to prepare your snow thrower for storage:

- Remove all gasoline from the carburetor and the fuel tank to prevent gum deposits from forming on these parts and causing possible malfunction of the engine.

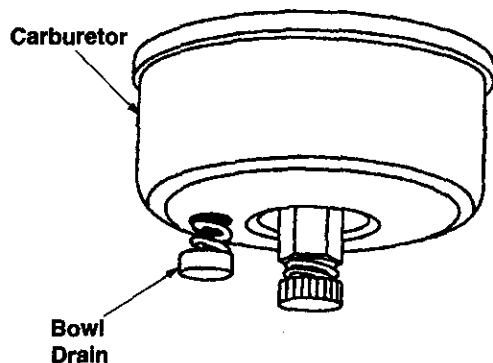

Figure 31



**WARNING:** Drain fuel into approved container outdoors, away from any open flame. Be certain engine is cool. Do not smoke.

Fuel left in engine during warm weather deteriorates and will cause serious starting problems.

- Run the engine until the fuel tank is empty and it stops due to lack of fuel.
- Drain carburetor by pressing upward on bowl drain, located below the carburetor cover. See Figure 31.



**WARNING:** Do not drain carburetor if using fuel stabilizer. Never use engine or carburetor cleaning products in the fuel tank or permanent damage may occur.

**NOTE:** Fuel stabilizer (such as STA-BIL) is an acceptable alternative in minimizing the formation of fuel gum deposits during storage. Add stabilizer to gasoline in fuel tank or storage container. Always follow mix ratio found on stabilizer container. Run engine at least 10 minutes after adding stabilizer to allow it to reach the carburetor. Do not drain carburetor if using fuel stabilizer.

- Remove the spark plug and pour one (1) ounce of engine oil through the spark plug hole into the cylinder. Place a rag over the hole. Crank the engine several times to distribute the oil. Replace spark plug.

## Preparing Snow Thrower

- When storing the snow thrower in an unventilated or metal storage shed, care should be taken to rustproof the equipment. Using a light oil or silicone, coat the equipment, especially any chains, springs, bearings and cables.
- Remove all dirt from exterior of engine and equipment.
- Follow lubrication recommendations on page 18.
- Store in a clean, dry area.



# TROUBLE-SHOOTING

Problem	Possible Cause	Corrective Action
Shift lever not locking into the sixth speed	1. Shift rod out of adjustment	1. Remove washer and pin. Turn ferrule clockwise one turn and reinstall.
Engine fails to start	1. Fuel tank empty, or stale fuel 2. Fuel shut-off valve closed 3. Ignition key not in switch or engine 4. Spark plug wire disconnected 5. Blocked fuel line 6. Faulty spark plug	1. Fill tank with clean, fresh gasoline. 2. Open valve. 3. Insert key. 4. Connect spark plug wire. 5. Clean fuel line. 6. Clean, adjust gap or replace.
Engine runs erratic.	1. Unit running on choke 2. Blocked fuel line or stale fuel 3. Water or dirt in fuel system.  4. Carburetor out of adjustment	1. Turn choke to off position. 2. Clean fuel line, fill tank with fresh fuel. 3. Drain carburetor following instructions on page 24. Refill with fresh fuel. 4. Contact Sears service center.
Loss of power	1. Spark plug wire loose 2. Gas cap vent hole plugged	1. Connect and tighten spark plug wire. 2. Remove ice and snow from cap. Make sure that the vent hole is clear.
Engine overheats	1. Engine oil level low. 2. Carburetor not adjusted properly	1. Fill crankcase with proper engine oil. 2. Contact Sears service center.
Excessive vibration	1. Loose parts or auger damaged	1. Stop engine immediately and disconnect spark plug wire. Tighten all nuts and bolts. Check for the source of vibration. Make all necessary repairs. If vibration persists, contact Sears service center.
Hard to shift speed, or will not shift	1. Shift rod not adjusted 2. Hex shaft not lubricated	1. Readjust shift rod. 2. Lubricate sprocket shaft.
Unit fails to propel itself	1. Incorrect adjustment of drive clutch  2. Drive belt loose or damaged	1. Adjust drive clutch.  2. Replace drive belt.
Unit fails to discharge snow	1. Auger shear bolt broken 2. Discharge chute clogged  3. Foreign object lodged in auger. 4. Auger drive clutch cable not adjusted. 5. Auger drive belt loose or damaged.	1. Replace shear bolt. 2. Stop engine, disconnect spark plug wire and clean discharge chute and inside of auger housing. 3. Stop engine, disconnect spark plug wire and remove object from auger. 4. Adjust properly. 5. Replace belt.
Track does not turn	1. Track control cable not inserted.  2. Lower cable bracket not fully positioned against gear box.	1. Insert the cable completely into the trigger assembly. 2. Loosen two self-tapping screws on each slot of bracket. Retighten making sure that the bolt is completely at the bottom of the slot.



For repairs beyond the minor adjustments listed above, please contact your nearest SEARS service center.

# PARTS LIST

SEARS CRAFTSMAN 9.0 H.P. SNOW THROWER MODEL 247.888550

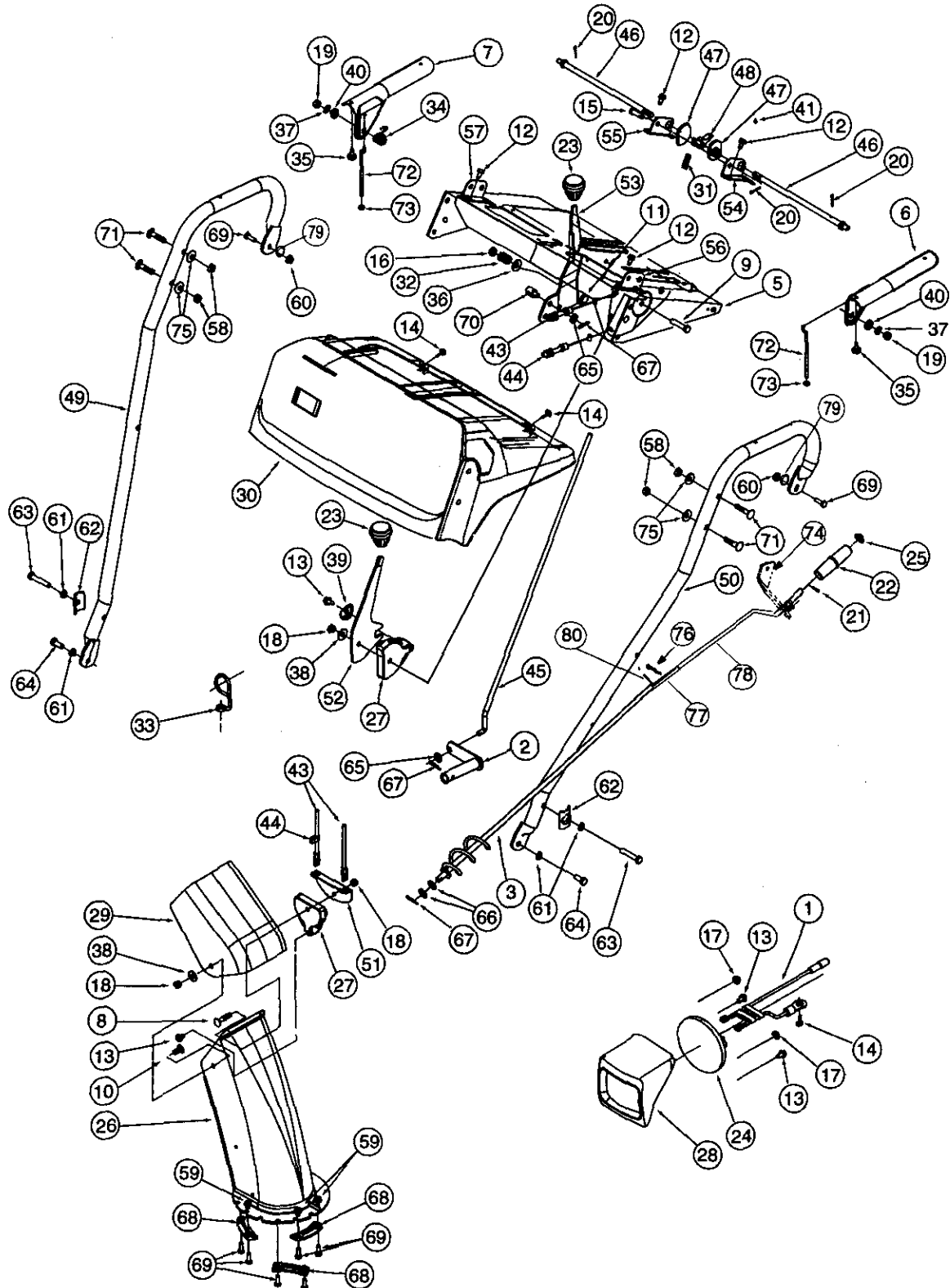

## SEARS CRAFTSMAN 9.0 H.P. SNOW THROWER MODEL 247.888550

Key No.	Part No.	Description	Qty.	Key No.	Part No.	Description	Qty.
1	629-0058	Harness for Headlight	1	40	736-0509	Special Washer	2
2	684-0008A-0637	Shift Arm Assembly	1	41	737-0133	Grease	1
3	684-0053	Chute Crank Assembly	1	43	746-0896	Chute Deflector Control Cable	1
4	684-0066	Hardware Pack*	1	44	746-0901	Chute Deflector Cable w/ Clip	1
5	684-0102	Handle Panel Assembly w/ Tilt	1	45	747-0798A	Shift Rod	1
6	684-0111	Handle Assembly Engagement (L.H.)	1	46	747-0877	Cam Rod	2
7	684-0112	Handle Assembly Engagement (R.H.)	1	47	748-0362	Cam Handle Lock	2
8	710-0262	Carriage Bolt 5/16-18 x 1.50	1	48	748-0363	Pawl Handle lock	1
9	710-0442	Hex Bolt 5/16-18 x 1.5	1	49	749-0908A	Right Handle	1
10	710-0451	Carriage Bolt 5/16-18 x .75	1	50	749-0909	Left Handle	1
11	710-0459	Hex Screw 3/8-24 x 1.5	1	51	784-5594	Cable Bracket	1
12	710-0599	Hex Washer Hd. TT Screw 1/4-20 x 0.5"	1	52	784-5604	Chute Tilt Handle	1
13	710-0896	Hex AB Tap Screw 1/4 x .62	2	53	784-5619A	Shift Handle	1
14	710-1003	Hex B-Tapp Scr # 10-16 x .62	2	54	784-5679	Handle Supt. Bracket LH 5/8	1
15	711-0653	Clevis Pin	1	55	784-5680	Handle Supt. Bracket RH 5/8	1
16	712-0116	Hex Ins. Lock Nut 3/8-24	9	56	784-5681	Handle Supt. Bracket LH 3/8	1
17	712-0415	Self Threading Nut	2	57	784-5682	Handle Supt. Bracket RH 3/8	1
18	712-0429	Lock Nut 5/16-18	2	58	712-3010	Hex Nut 5/16-18 Thd.	4
19	712-3010	Hex Nut	3	59	712-3027	Hex Fl. Lock Nut 1/4-20 Thd.	8
20	714-0507	Cotter Pin	3	60	712-0287	Hex Nut 1/4-20	2
21	715-0138	Roll Pin	1	61	736-0119	Lock Washer 5/16	4
22	720-0201A	Chute Crank Knob	1	62	784-5599	Handle Tab	2
23	720-0300	Shift Knob	2	63	710-3180	Hex Bolt 5/16-18 x 1.75 Gr.5	2
24	725-1300	Headlight	1	64	710-3008	Hex Bolt	2
25	726-0100	Push Cap	1	65	736-0275	Flat Washer 5/16	2
26	731-1300A	Lower Chute	1	66	736-0185	Flat Washer 3/8 x .738 x .063	2
27	731-1313C	Cable Guide	2	67	714-0104	Hairpin Clip	3
28	731-1317	Headlight Bezel	1	68	731-0851A	Chute Flange Keeper	3
29	731-1320	Upper Chute	1	69	710-3015	Hex Bolt 1/4-20 x 0.75" Gr.5	8
30	731-1773A	Handle Panel	1	70	711-0677	Ferrule	1
31	732-0145	Compression Spring	1	71	710-0262	Carriage Bolt 5/16-18 x 1.50	4
32	732-0193	Compression Spring	1	72	746-0778	Z Fitting	2
33	732-0705	Cable Control Wire	1	73	712-0121	Hex Nut # 10-24	2
34	732-0746	Torsion Spring	1	74	705-5266	Chute Crank Reinforcement Bracket	1
35	735-0199A	Rubber Bumper	2	75	736-0242	Cupped Washer .340 I.D. x .872 O.D.	4
36	736-0105	Bell Washer .380 x .880 x .062	1	76	714-0101	Hairpin Clip	1
37	736-0119	Lock Washer 5/16 I.D.	2	77	750-0785	Spacer	1
38	736-0159	Washer 5/6 I.D.	2	78	747-0737	Upper Chute crank	1
39	736-0506	Special Washer	1	79	736-0270	Bell Washer	2
				80	715-0138	Roll Pin	2

\* Includes references 58 through 75

**NOTE:** For **paint**ed parts, please refer to the list of color codes below. Please add the applicable color code, wherever needed, to the part number to order a replacement part. For instance, if a part, numbered 700-xxxx, is painted polo green, the part number to order would be 700-xxxx-0689.

Polo Green: 0689

Powder Black: 0637

SEARS CRAFTSMAN 9.0 H.P. SNOW THROWER MODEL 247.888550

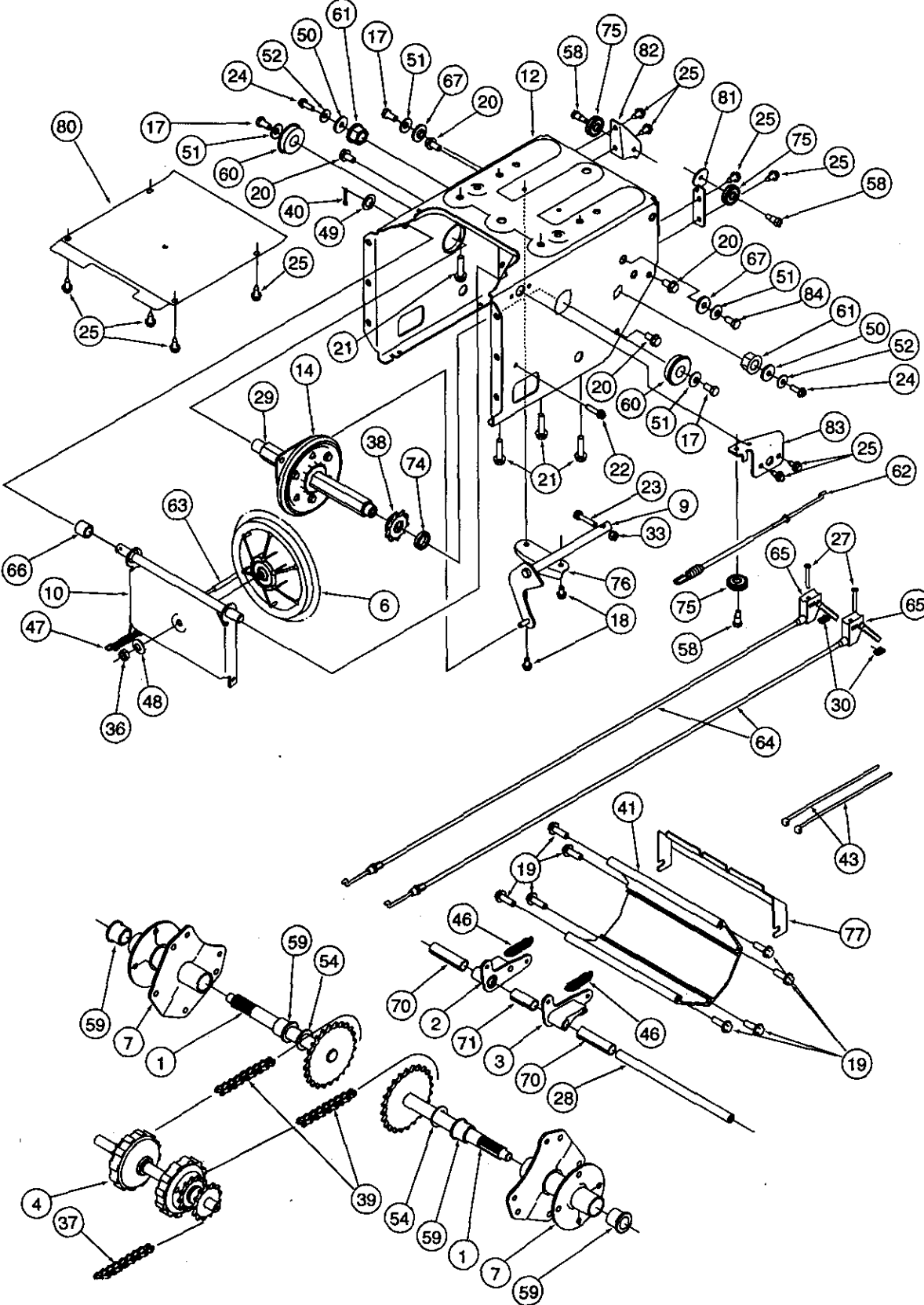

## SEARS CRAFTSMAN 9.0 H.P. SNOW THROWER MODEL 247.888550

Key No.	Part No.	Description	Qty.	Key No.	Part No.	Description	Qty.
1	611-0053	Axle Assembly	2	41	719-0295A	Track Housing	1
2	618-0043	Dogg Assembly: RH	1	43	725-0157	Cable Tie	2
3	618-0044	Dogg Assembly: LH	1	46	732-0209	Extension Spring	2
4	618-0169	Shift Assembly: Track Drive	1	47	732-0264	Extension Spring	1
7	683-0024	Hub Assembly: Track Drive	2	48	736-0105	Bell Washer	1
9	684-0014B	Shift Rod Assembly	1	49	736-0160	Flat Washer	1
10	684-0021	Friction Wheel Support Bracket Assembly	1	50	736-0176	Flat Washer	2
12	684-0031	Frame Assembly	1	51	736-0242	Bell Washer	5
14	684-0042B	Friction Wheel Bearing Assembly	1	52	736-0270	Bell Washer	2
17	710-0643	Hex Lock Screw 5/16-18 x .625 Grade 5	4	54	736-0287	Flat Washer	2
18	710-0599	Hex Washer Hd. TT Screw	2	58	738-0924	Shoulder Screw	3
19	710-0602	Hex Washer Hd. TT Screw	8	59	741-0339	Flange Bearing	4
20	710-0604	Hex Washer Hd. TT Screw	6	60	741-0563	Ball Bearing	2
21	710-0654A	Hex Washer Hd. TT Screw	4	61	741-1111	Hex Flange Bearing	2
22	710-0788	Hex Washer Screw	1	62	746-0897	Auger Clutch Cable	1
23	710-0809	Hex Washer Screw	1	63	746-0898	Drive Clutch Cable	1
24	710-0875	TT Screw	2	64	746-0948	Track Steering Cable	2
25	710-0896	Hex Washer Head AB Screw	10	65	746-0950	Trigger Control	2
27	710-1233	Oval C-Sunk Screw	2	66	748-0190	Spacer	1
28	711-0911	Actuator Shaft	1	67	748-0234	Shoulder Spacer	2
29	711-1042	Hex Shaft: Track Drive	1	70	750-0903	Split Spacer	2
30	712-0127	Flanged Weld Nut #10-24	2	71	750-0904	Split Spacer	1
33	712-0324	Top Lock Nut 1/4-20	1	74	750-0997	Spacer	1
36	712-0711	Jam Nut 3/8-24	1	75	756-0625	Roller Cable	3
37	713-0233	Chain Links	1	76	784-5590	Shift Bracket	1
38	713-0413	Sprocket: 10T	1	77	784-5609	Steering Cable Bracket	1
39	713-0437	Chain	2	80	784-5648	Frame Cover	1
40	714-0474	Cotter Pin	1	81	784-5687A	Auger Clutch Cable Bracket	1
				82	784-5688	Drive Cable Bracket	1
				83	784-5689A	Front Support Bracket	1

**NOTE:** For **painted parts**, please refer to the list of color codes below. Please add the applicable color code, wherever needed, to the part number to order a replacement part. For instance, if a part, numbered 700-xxxx, is painted polo green, the part number to order would be 700-xxxx-0689.

Polo Green: 0689

Powder Black: 0637

SEARS CRAFTSMAN 9.0 H.P. SNOW THROWER MODEL 247.888550

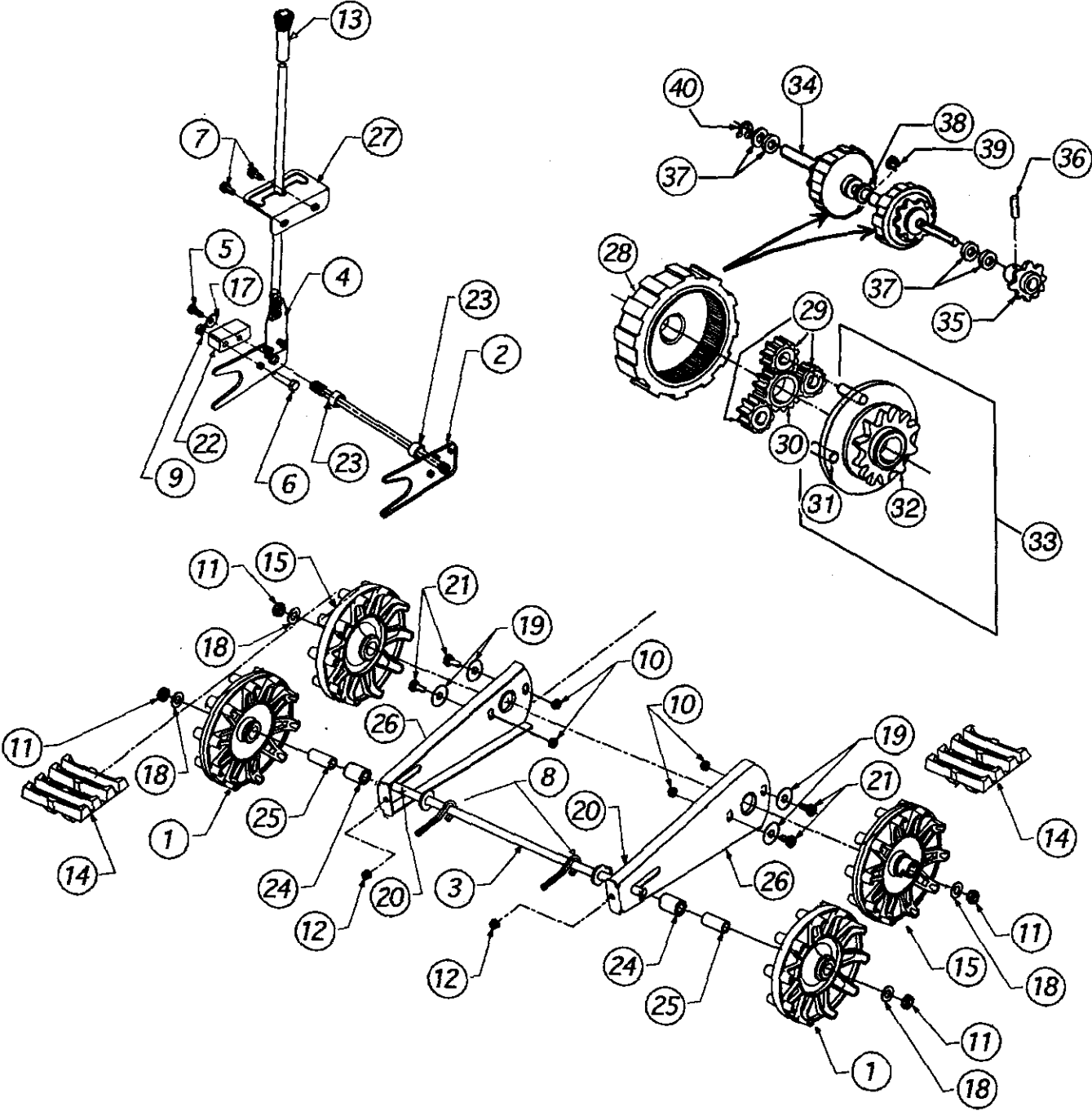

**SEARS CRAFTSMAN 9.0 H.P. SNOW THROWER MODEL 247.888550**

Key No.	Part No.	Description	Qty.	Key No.	Part No.	Description	Qty.
1	631-0032	Wheel Assembly Idler	2	23	750-0547	Spacer	2
2	684-0009	Rod Track Pivot	1	24	750-0909	Spacer	2
3	684-0024	Axle Assembly	1	25	750-0995	Spacer	2
4	684-0038	Handle Assembly	1	26	784-5639-0483	Plate-Track Side	2
5	710-0157	Screw	1	27	784-5642	Plate-Track Lockout	1
6	710-0459	Screw	1	28	717-1211	Gear Ring	2
7	710-0604	Screw	2	29	717-1209	Gear 12-Tooth	6
8	710-1231	Screw	2	30	717-1210	Gear 18-Tooth	2
9	712-0214	Lock Nut	1	31	741-0542	Pin Dowel	6
11	712-0346	Jam Nut	4	32	718-0188	Carrier	2
12	712-0429	Hex Nut	6	33	618-0046	Carrier Assembly	2
13	720-0223	Grip	1	34	711-0912	Shaft—Track Drive	1
14	731-1292	Track	2	35	713-0414	Sprocket—13 Tooth	1
15	731-1538A	Wheel-Track Drive	2	36	715-0120	Spring Pin	1
17	736-0242	Bell Washer	1	37	736-0502	Flat Washer	6
18	736-0272	Flat Washer	4	38	736-0336	Flat Washer	2
19	736-0406	Flat Washer	4	39	716-0115	Snap Ring .625" Shaft	2
20	737-0170	Lubricant	1	40	716-0114	Snap Ring .56" Shaft	1
21	738-0140	Shoulder Screw	4				
22	748-0353A	Lift-Shaft Drive	1				

**LABELS**

Key No.	Part No.	Description	Qty.
1	777I20077	Traction Control RH	1
2	777I20078	Traction Control LH	1
3	777I20079	Chute Tilt	1
4	777I20401	Auger Control	1
5	777I20402	Traction Drive	1
6	777I20404	Transport	1
7	777S30005	Danger Warning	1
8	777S30004	Danger, Top of Chute	1

**NOTE:** For painted parts, please refer to the list of color codes below. Please add the applicable color code, wherever needed, to the part number to order a replacement part. For instance, if a part, numbered 700-xxxx, is painted polo green, the part number to order would be 700-xxxx-0689.

Polo Green: 0689  
Powder Black: 0637

**SEARS CRAFTSMAN 9.0 H.P. SNOW THROWER MODEL 247.888550**

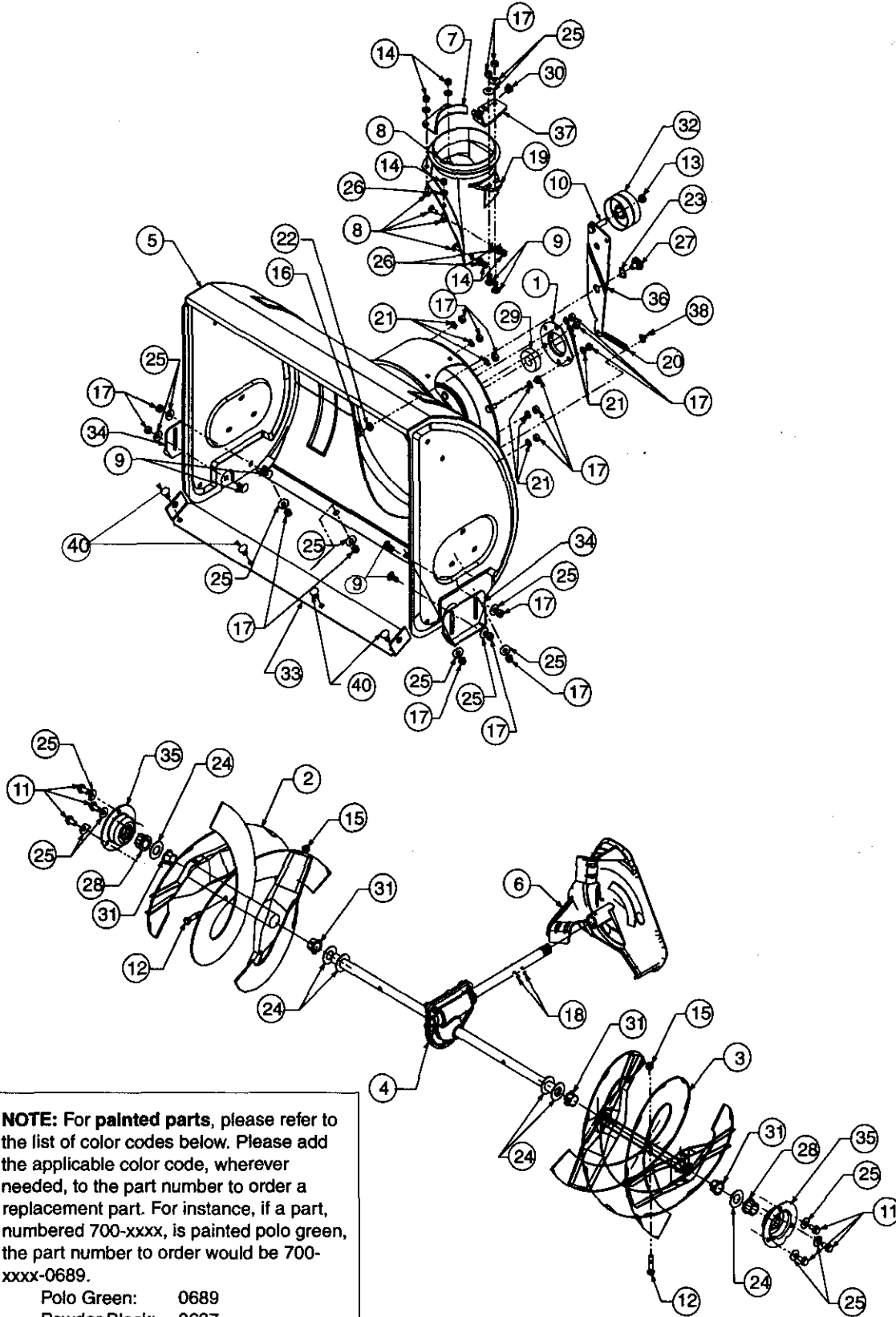

**NOTE:** For painted parts, please refer to the list of color codes below. Please add the applicable color code, wherever needed, to the part number to order a replacement part. For instance, if a part, numbered 700-xxxx, is painted polo green, the part number to order would be 700-xxxx-0689.

Polo Green:	0689
Powder Black:	0637



**SEARS CRAFTSMAN 9.0 H.P. SNOW THROWER MODEL 247.888550**

Key No.	Part No.	Description	Qty.	Key No.	Part No.	Description	Qty.
1	05931	Bearing Housing	1	20	732-0611	Extension Spring	1
2	605-5192A	Spiral Assembly	1	21	736-0119	Lock Washer 5/16	9
3	605-5193A	Spiral Assembly	1	22	736-0169	Lock Washer 3/8	1
4	618-0121	Auger Gear Assembly	1	23	736-0174	Wave Washer	1
5	684-0040A	Spiral Housing Assembly	1	24	736-0188	Flat Washer .76 I.D. x 1.49 O.D.	6
6	684-0065	Impeller Assembly	1	25	736-0242	Bell Washer .345 I.D. x .88	16
7	705-5226	Chute Reinforcement	1	26	736-0463	Flat Washer 1/4 x .630	5
8	710-0703	Carriage Screw 1/4-20 X .75	5	27	738-0281	Shoulder Screw	1
9	710-0451	Carriage Bolt 5/16-18 X .75	10	28	741-0245	Hex Flange Bearing	2
10	710-0459A	Hex Scr 3/8-24 X 1.5	1	29	741-0309	Ball Bearing	1
11	710-0604	Hex Washer Head TT-Screw 5/16-18 X .62	6	30	741-0475	Plastic Bushing	1
12	710-0890A	Shear Bolt 5/16-18 X 1.5	2	31	741-0493A	Flange Bushing	4
13	712-0116	Jam Lock Nut	1	32	756-0178	Flat Idler	1
14	712-0324	Toplock Nut 1/4-20	5	33	784-5582A	Shave Plate	1
15	712-0429	Hex Lock Nut 5/16-18	2	34	784-5580	Slide Shoe	2
16	712-0798	Hex Nut 3/8-16	1	35	784-5618	Bearing Assembly	2
17	712-3010	Hex Nut 5/16-18	19	36	784-5632A	Auger Idler Arm	1
18	715-0114	Spiral Pin	2	37	784-5647	Chute Crank Bracket	1
19	731-1379A	Chute Adapter	1	38	712-3068	Patch Nut 5/16-18	1
				39	737-3007	Grease	1
				40	710-0260	Carriage Bolt 5/16-18 x .62"	4

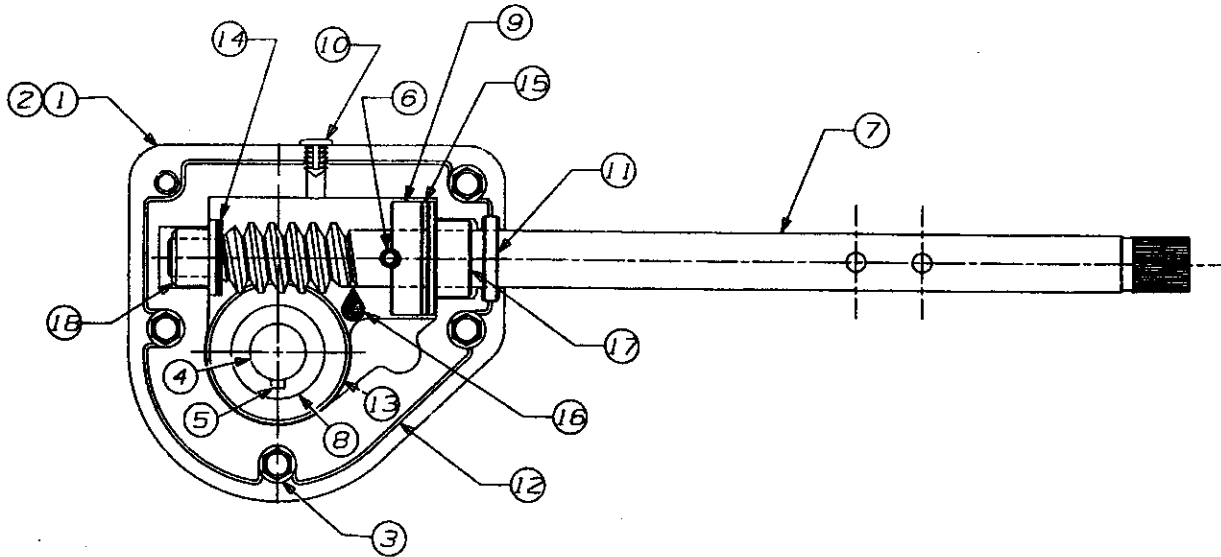

Key No.	Part No.	Description	Qty.	Key No.	Part No.	Description	Qty.
1	618-0123	Housing—RH	1	10	721-0325	Plug	1
2	618-0124	Housing—LH	1	11	721-0327	Seal, Oil	1
3	710-0642	Screw	5	12	721-0328	Loctite 5699, Ultra	1
4	711-0909	Spiral Axle	1	13	736-0351	Washer	2
5	714-0161	Key, Hi-Pro	1	14	736-0369	Washer	4
6	715-0143	Spiral Pin	1	15	736-0445	Washer	1
7	717-0526	Shaft Worm	1	16	737-0168	Grease	1
8	717-0528	Worm Gear	1	17	741-0662	Flange Bearing	1
9	718-0186	Thrust Collar	1	18	741-0663	Flange Bearing	1

**SEARS CRAFTSMAN 9.0 H.P. SNOW THROWER MODEL 247.888550**

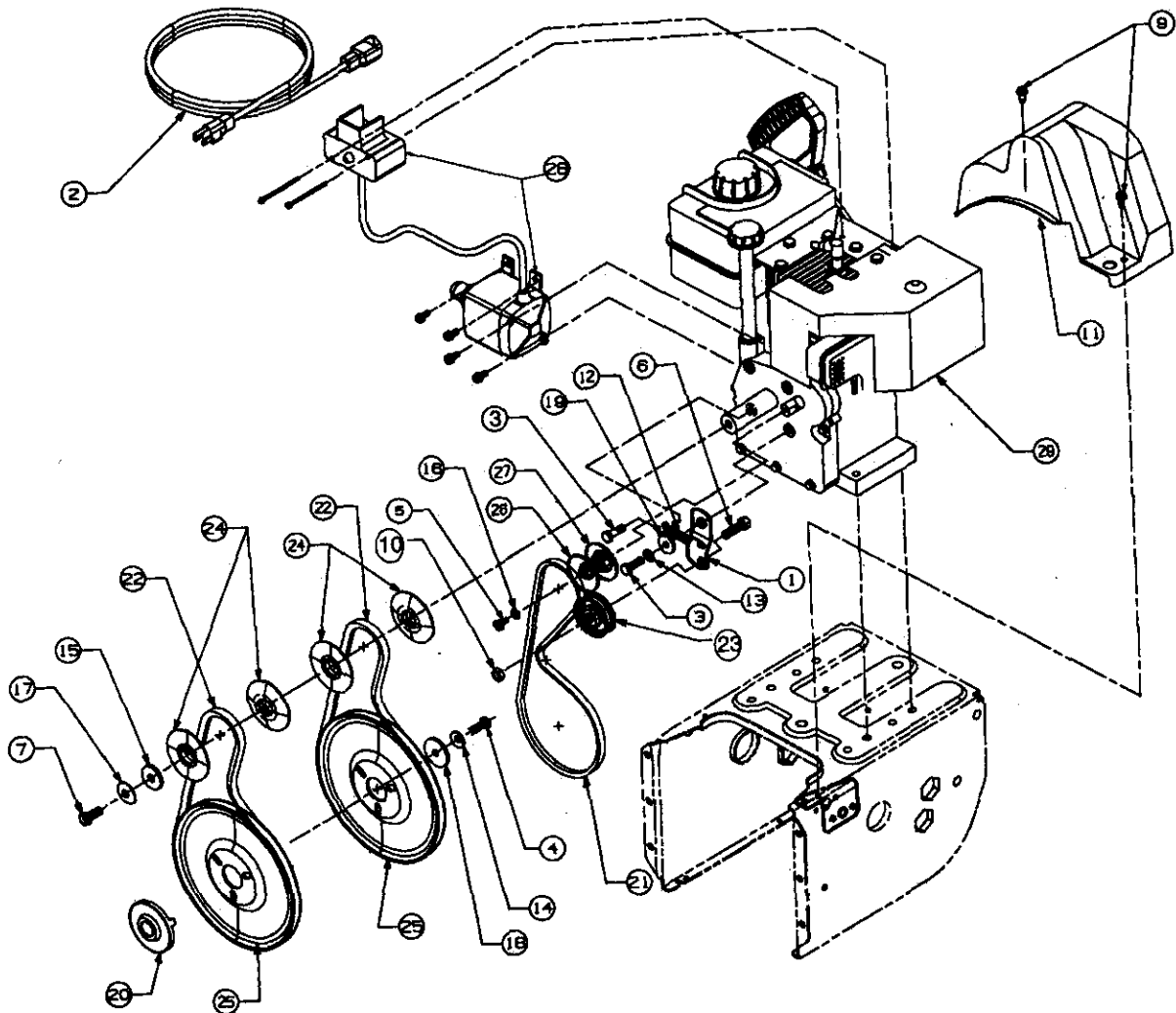

Key No.	Part No.	Description	Qty.	Key No.	Part No.	Description	Qty.
1	05896A	Bracket	1	18	736-0505	Flat Washer	1
2	629-0071	Extension Cord	1	19	748-0234	Shoulder Spacer	1
3	710-0627	Screw	2	20	748-0360	Adapter Pulley	1
4	710-1245	Screw	1	21	754-0346	V-Belt	1
5	710-0230	Screw	1	22	754-0430	V-Belt Matched	2
6	710-3005	Screw	1	23	756-0313	Flat Idler	1
7	710-0696	Screw	1	24	756-0569	Half Pulley	4
9	710-1652	Screw	2	25	756-0967	Auger Pulley	2
10	712-0181	Jam Nut	1	26	756-0986	Pulley Half	1
11	731-1324	Belt Cover	1	27	756-0987	Pulley Half	1
12	732-0710	Spring	1	28	390-987	Starter	1
13	736-0119	Flat Washer	1	29	—	Engine, Craftsman model 143.999005	1
14	736-0242	Bell Washer	1	30	770-10051C	Owner's Manual (Not Shown)	1
15	736-0247	Flat Washer	1	31	737-3007	Grease	1
16	736-0270	Lock Washer	1				
17	736-0331	Bell Washer	1				

Craftsman Engine Model No. 143.999005 for Craftsman Snow Thrower Model 247.888550

CARBURETOR

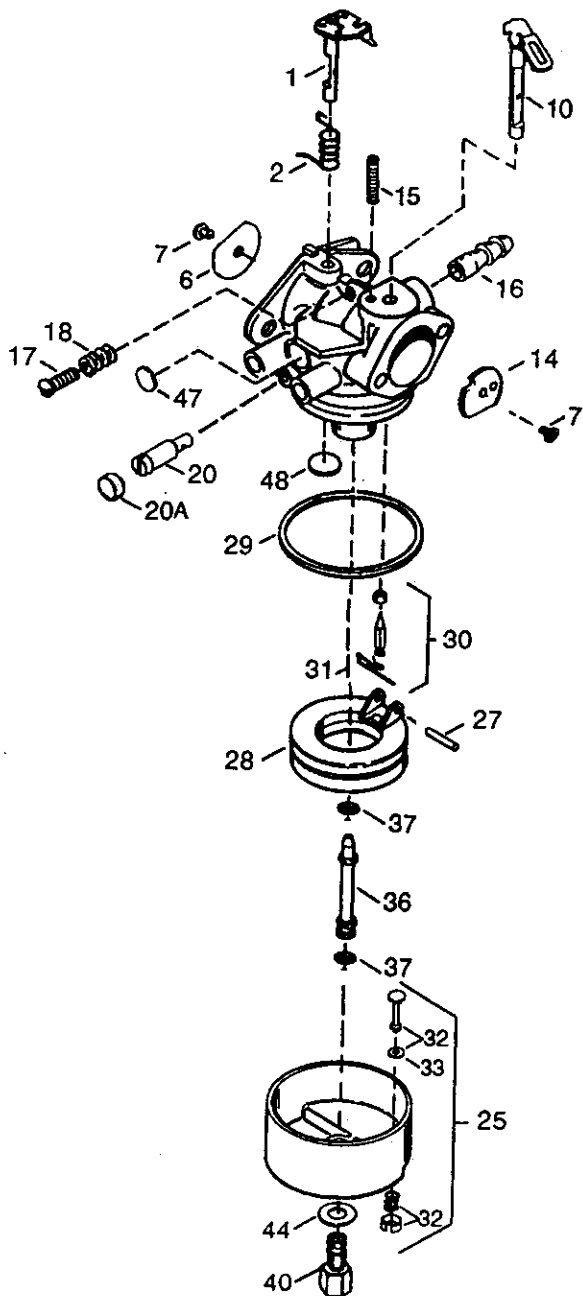

Key No.	Part No.	Description	Qty.
0	640052	Carburetor (Incl. 184 of Engine Parts List)	1
1	631776A	Throttle Shaft & Lever Ass'y.	1
2	631970	Throttle Return Spring	1
6	631778	Throttle Shutter	1
7	650506	Shutter Screw	2
10	632112	Choke Shaft & Lever Ass'y.	1
14	632174	Choke Shutter	1
15	630735	Choke Positioning Spring	1
16	632164	Fuel Fitting	1
17	650417	Throttle Crack Screw/Idle Speed Screw	1
18	630766	Tension Spring	1
20	640016	Idle Restrictor Screw	1
20A	640053	Idle Restrictor Screw Cap	
25	631951	Float Bowl Ass'y. (Incl. 32 & 33)	1
27	631024	Float Shaft	1
28	632019	Float	1
29	631028	Float Bowl "O" Ring	1
30	631021	Inlet Needle, Seat & Clip (Incl. 31)	1
31	631022	Spring Clip	1
32	27136A	Bowl Drain Ass'y.	1
33	27554	Drain Plunger Gasket	1
36	640005	Main Nozzle Tube	1
37	632547	O Ring	2
40	640055	High Speed Bowl Nut	1
44	27110	Bowl Nut Washer	1
47	630748	Welch Plug, Idle Mixture Well	1
48	631027	Welch Plug, Atmospheric Vent	1

Craftsman Engine Model No. 143.999005 for Craftsman Snow Thrower Model 247.888550

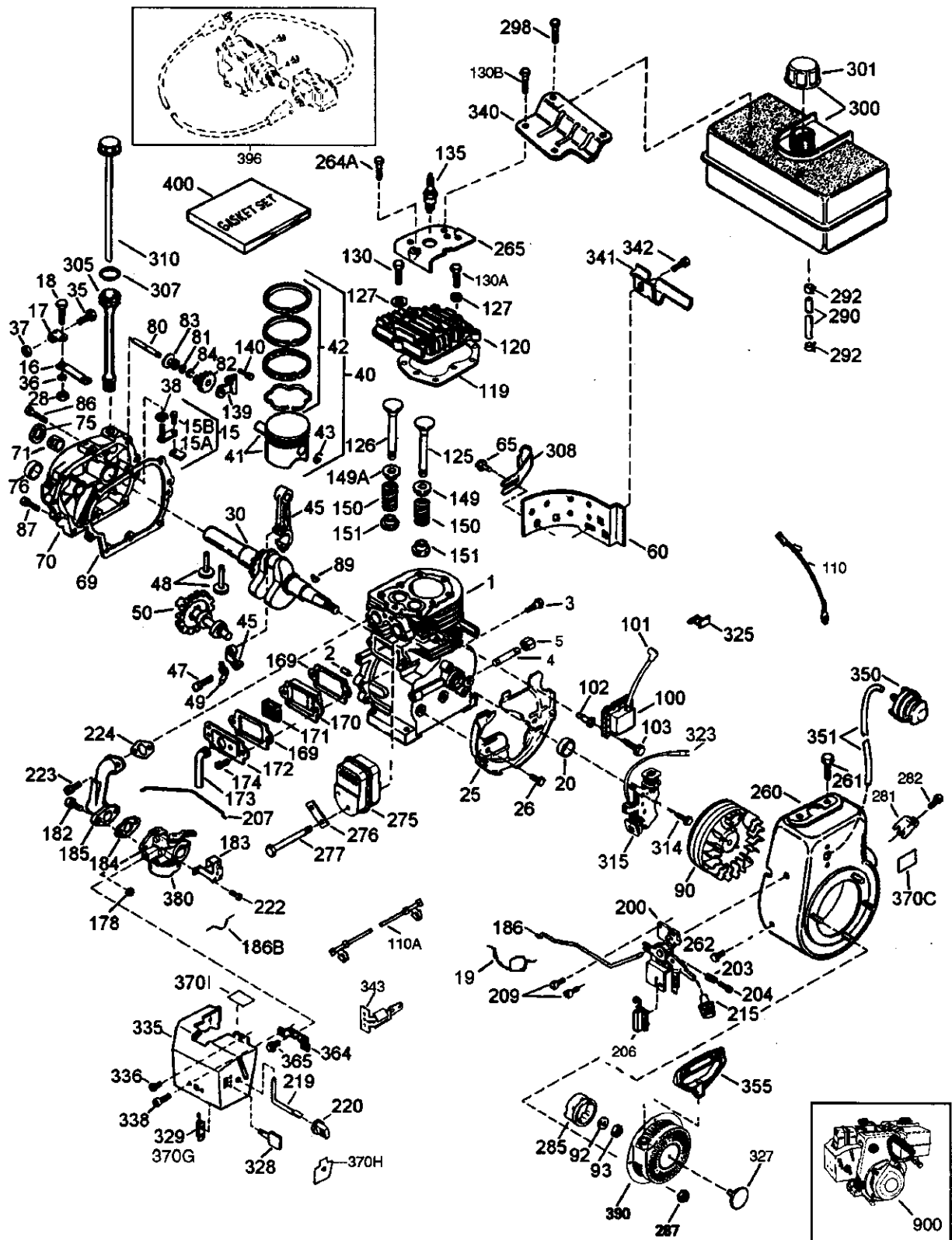

**Craftsman Engine Model No. 143.999005 for Craftsman Snow Thrower Model 247.888550**

Key No.	Part No.	Description	Qty.	Key No.	Part No.	Description	Qty.
1	35385	Cylinder	1	90	611093	Flywheel (W/ Ring Gear)	1
2	27652	Dowel Pin	2	92	650880	Belleville Washer	1
3	650820	Screw	2	93	650881	Flywheel Nut	1
4	—	Oil Drain Extension	1	100	35135	Solid State Ignition	1
5	30969	Extension Cap	1	101	610118	Spark Plug Cover	1
15	30699C	Governor Rod	1	102	651024	Solid State Mounting Stud	2
15A	30700	Governor Yoke	1	103	651007	Screw, Torx	2
15B	650494	Screw	1	110	35187	Ground Wire	1
16	33454	Governor Lever	1	110A	37047	Ground Wire	1
17	29916	Governor Lever Clamp	1	119	36448	Cylinder Head Gasket	1
18	651028	Screw, Torx	1	120	36449	Cylinder Head	1
19	34663	Speed Control Spring	1	125	27878A	Exhaust Valve (Std.)	1
20	35319	Oil Seal	1	125	27880A	Exhaust Valve (1/32" Os)	1
25	36460	Blower Housing Baffle	1	126	34035	Intake Valve(Std.)	1
26	650561	Screw	2	126	34036	Intake Valve (1/32" Os)	1
28	30322	Lock Nut	1	127	650691	Washer	2
30	35980A	Crankshaft	1	130	6021A	Screw	7
35	29826	Screw	1	130A	650727	Screw	2
36	29918	Lock Washer	1	130B	650727	Screw	2
37	29216	Lock Nut	1	135	35395	Resistor Spark Plug	1
38	29642	Retaining Ring	1	139	33369	Governor Gear Bracket	1
40	40011	Piston, Pin & Ring Set (Std.)	1	140	650836	Screw	2
40	40012	Piston, Pin & Ring Set (.010" OS)	1	149	27882	Valve Spring Cap	1
41	40009	Piston, & Pin Ass'y.(Std.)	1	149A	35862	Valve Spring Cap	1
41	40010	Piston, & Pin Ass'y.(.010" OS)	1	150	27881	Valve Spring	2
42	40013	Ring Set (Std.)	1	151	32581	Valve Spring Keeper	2
42	40014	Ring Set (.010" OS)	1	169	27896A	Valve Cover Gasket	1
43	27888	Piston Pin Retaining Ring	2	170	28423	Breather Body	1
45	36897	Connecting Rod Ass'y.	1	171	28424	Breather Element	1
47	651033	Connecting Rod Bolt	2	172	28425	Valve Cover	1
48	34034	Valve Lifter	2	173	35350	Breather Tube	1
49	36896	Oil Dipper	1	174	650128	Screw	2
50	36655	Camshaft (MCR)	1	178	29752	Nut & Lock Washer	2
60	33273A	Blower Housing Extension	1	182	30088A	Screw	2
65	650128	Screw	1	183	34587A	Choke Bracket	1
69	35262A	Cylinder Cover Gasket	1	184	33263	Carburetor to intake pipe gasket	1
70	35445A	Cylinder Cover	1				
71	35377	Crankshaft Bushing	1	185	33877	Intake Pipe	1
75	35319	Oil seal	1	186	34667	Governor Link	1
76	28926	Camshaft Seal	1	186B	36652	Choke Spring	1
80	31845	Governor Shaft	1	200	34677	Control Bracket	1
81	30590A	Washer	1	203	31342	Compression Spring	1
82	35378	Governor Gear Asss'y.	1	204	651029	Torx. Screw	1
83	30588A	Governor Spool	1	206	610973	Terminal	1
84	29193	Retaining Ring	1	207	33878	Throttle Link	1
86	650833	Screw	7	209	650821	Screw	2
87	650832	Screw	1	215	35440	Control Knob	1
89	32589	Flywheel Key	1	219	34586	Choke Rod	1

Table continued on next page

**Craftsman Engine Model No. 143.999005 for Craftsman Snow Thrower Model 247.888550**

Table continued from previous page

Key No.	Part No.	Description	Qty.	Key No.	Part No.	Description	Qty.
220	35438	Choke Knob	1	323B	611118	Terminal	1
222	28820	Screw	2	325	29443	Wire Clip	1
223	650378	Screw, Torx	2	327	35392	Starter Plug	1
224	27915A	Intake Pipe Gasket	1	328	35593	Ignition Key	2
260	35447A	Blower Housing	1	329	610973	Terminal	1
261	650788	Screw	2	335	35057A	Carburetor Cover	1
262	29747B	Screw, Torx	2	336	650765	Screw	1
264A	650802	Screw	1	338	28942	Screw	2
265	33272B	Cylinder Head Cover	1	340	34154	Fuel Tank Bracket	1
275	35056	Muffler	1	341	34155	Fuel Tank Bracket	1
276	31588	Locking Plate	1	342	650561	Screw	1
277	651002	Screw	2	343	35079	Key Switch Bracket	1
281	33013	Starter Bubble Cover	1	350	570682	Primer Bulb	1
282	650760	Screw	1	351	32180C	Primer Line	1
285	35985B	Starter Cup	1	355	590574	Starter Handle	1
287	29752	Nut & Lock Washer	4	364	33377	Carburetor Cover Bracket	1
290	30705	Fuel Line	1	365	650767	Screw	2
292	26460	Fuel Line Clamp	4	370C	36501	Primer Decal	1
298	650665	Screw	2	370H	35077	Choke Decal	1
300	34156A	Fuel Tank	1	370I	35878	Warning Decal	1
301	35355	Fuel Cap	1	380	640052	Carburetor	1
305	35554	Oil Fill Tube	1	390	590749	Rewind Starter	1
307	35499	"O" Ring	1	396	37000	Electric Starter Motor	1
308	35540	Fill Tube Clip	1	400	36450A	Gasket Set	1
310	36205	Dipstick	1	900	—	Replacement Engine—none	0
314	650873	Screw	1	900	—	Replacement Short Block	
315	611111	Alternator Coil	1			756325	
						Order from 71-999	

**Craftsman Engine Model No. 143.999005 for Craftsman Snow Thrower Model 247.888550**

**Recoil Starter**

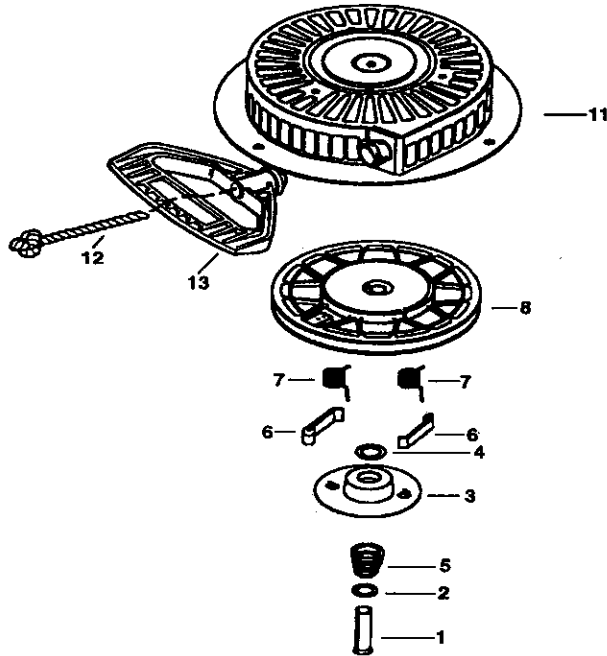

Key No.	Part No.	Description	Qty.
0	590733	Rewind Starter	1
1	590599A	Spring Pin (Incl. 4)	1
2	590600	Washer	1
3	590696	Retainer	1
4	590601	Washer	1
5	590697	Brake Spring	1
6	590698	Starter Dog	2
7	590699	Dog Spring	2
8	590709	Pulley & Rewind Spring Ass'y.	1
11	590734	Starter Housing Ass'y.	1
12	590535	Starter Rope (Length 98" x 9/64" Dia.)	1
13	590574	Mitten Grip Handle (Not Included With Starter)	1

**Recoil Starter (Optional)**

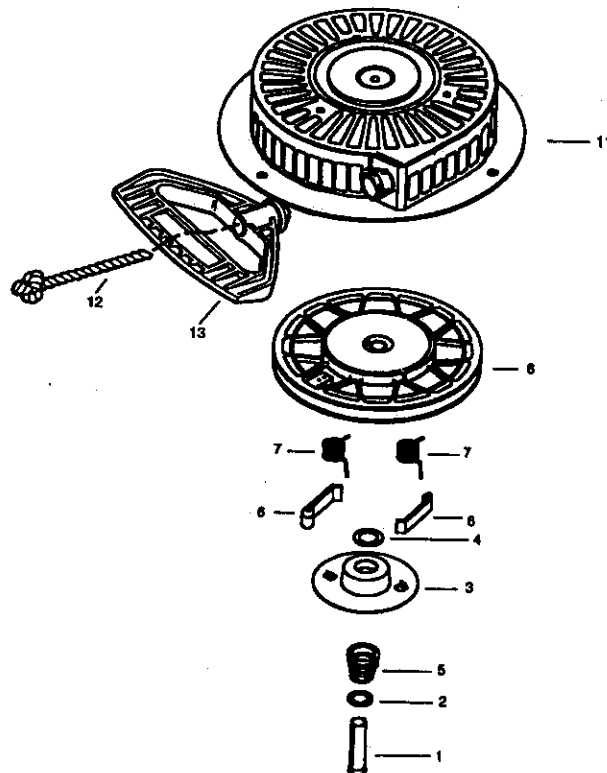

Key No.	Part No.	Description	Qty.
0	590749	Rewind Starter	1
1	590599A	Spring Pin (Incl. 4)	1
2	590600	Washer	1
3	590679	Retainer	1
4	590601	Washer	1
5	590678	Brake Spring	1
6	590680	Starter Dog	2
7	590412	Dog Spring	2
8	590682	Pulley & Rewind Spring Ass'y.	1
11	590750	Starter Housing Ass'y.	1
12	590535	Starter Rope (Length 98" x 9/64" Dia.)	1
13	590574	Mitten Grip Handle (Not Included With Starter)	1

# YOUR NOTES

Comments	Date



**In U.S.A. or Canada**

**for in-home major brand repair service:**

Call 24 hours a day, 7 days a week

**1-800-4-MY-HOME<sup>SM</sup> (1-800-469-4663)**

**Para pedir servicio de reparación a domicilio — 1-800-676-5811**

**Au Canada pour tout le service ou les pièces — 1-800-469-4663**

**For the repair or replacement parts you need:**

Call 6 a.m. — 11 p.m. CST, 7 days a week

**PartsDirect<sup>SM</sup>**

**1-800-366-PART (1-800-366-7278)**

**Para ordenar piezas con entrega a domicilio — 1-800-659-7084**

**For the location of a Sears Service Center in your area:**

Call 24 hours a day, 7 days a week

**1-800-488-1222**

**To purchase or inquire about a Sears Maintenance Agreement:**

Call 7 a.m. — 5 p.m. CST, Monday — Saturday

**1-800-827-6655**

