

MODEL NO.
298.585070

- owner's responsibility
- maintenance
- operation
- trouble shooting
- replacement parts

Sears **GAMEFISHER[®]**

OUTBOARD MOTOR 1.75 H.P.

CAUTION: Read Rules For Safe Operation And Instructions Carefully
Before Operating Your New Outboard Motor

**OWNER'S
MANUAL**

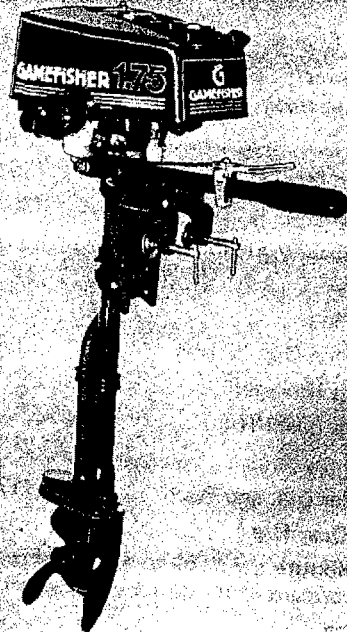

Publication No.
970-35351-201

TABLE OF CONTENTS

Page No.

SPECIFICATIONS	1
OWNER'S RESPONSIBILITY	2
MAINTENANCE	4
LUBRICATION GEAR HOUSING	4
MUFFLER INSPECTION	4
PROLONGED STORAGE	4
OPERATIONS	5
BOAT MOUNTING	5
STEERING ADJUSTMENT	5
2-CYCLE ENGINE FUEL MIXTURE	6
STARTING PROCEDURES	6
STOPPING PROCEDURES	6
FLOODING	7
CARBURETOR ADJUSTMENTS	7
PROPELLER SHEAR PIN	7
IGNITION SYSTEM	8
REMOVING MOTOR FROM BOAT	8
SALT WATER OPERATIONS	8
TROUBLE SHOOTING CHECK LIST	9
REPLACEMENT PARTS	10
ORDERING PROCEDURES	Outside Back Cover
PRODUCT WARRANTY	Outside Back Cover

SPECIFICATION

Type of Engine	Air Cooled 2-Cycle
Horsepower	1.75
Maximum RPM	8000
Weight	(9 kg) 19.8 Lbs. Approx.
Bore and Stroke	(36 mm x 30 mm) 1.42" x 1.18"
Displacement	(30.5 cc) 1.86 cu.in.
Fuel Capacity-Engine Tank	(0.8 liters) 4/5 qt.
Ignition	Flywheel Magneto
Spark Plug	Champion RCJ-8
Spark Plug Gap Setting	(0.6 mm) .025"
Bearings (Engine)	Ball
Bearings (Gear Hsg.)	Ball & Oilite Bronze
Starter	Recoil
Propeller Dia. and Pitch	(171 mm x 104.4 mm) 6.73" x 4.11"
Lub. (Gear Hsg.)	SAE 90
Fuel Mixture . . .	50 to 1 ratio of regular grade gasoline to 2-cycle outboard lubricant or its equivalent BIA certified TC-W 2-cycle outboard lubricant.
Steering	243° Pivot Steering

IMPORTANT

Owner's Responsibility and Operating Safety Check List

BE SURE TO READ AND DO THE FOLLOWING BEFORE OPERATING YOUR OUTBOARD MOTOR

SAFETY CHECK LIST

1. Learn and observe the boating laws of the U.S. Coast Guard, state, local authorities.
2. U.S. Coast Guard regulations require the following:
 - a. Provide an approved life-vest, type 1, 2 or 3, Personal Flotation Device for each person in boat. (Encourage passengers to wear them.)
 - b. If the boat exceeds 16 feet, also carry a type 4, throwable Personal Flotation Device.
3. Do not fill fuel tank with motor running or near any flame or lighted smoking material.
4. When loading boat distribute the load evenly, keep the load low; don't overload; don't stand in a small boat. Take weather and water conditions into account.
5. Do not permit persons to ride on parts of the boat not designed for such use. Standing, bow riding and seat back or gunwale riding can be especially dangerous.

OWNER'S RESPONSIBILITY

6. Read owner's manual before running your new outboard motor.
7. Before starting, make sure your motor is securely mounted to boat transom with a safety chain. Tighten clamp stud handles securely by hand.
8. Be sure to have pliers, screwdriver, spare spark plugs, wrench, shear pins and cotter pins in boat whenever leaving shore.
9. Be sure to have an adequate supply of fuel (carry only in an approved container) on board. Use a good grade of regular gasoline with proper mixture, as cited in the Specifications.
10. Occasionally check to be sure clamp stud handles on transom mounting bracket are tight.
11. IN CASE OF AN EMERGENCY, THE ENGINE CAN BE STOPPED BY DEPRESSING THE STOP BUTTON OR PLACING CHOKE KNOB IN FULL CHOKE POSITION.
12. Keep an alert lookout. Serious accidents have resulted from failure to use eyes.
13. Keep firefighting and lifesaving equipment in good condition and readily accessible at all times.
14. Good housekeeping is even more important afloat than ashore. Cleanliness diminishes the probability of fire and tripping hazards.

TIPS FOR TRAILERING OR AUXILIARY USE

15. When launching or loading boat on a trailer, place your outboard motor in the tilted storage position. Also when trailering your boat and outboard motor, keep outboard motor in upright (vertical) position on the boat transom. Outboard motors transported across rough roads in the "tilt" position could cause transom damage or mounting brackets to break off, losing your motor. If motor must be trailered in "tilt" position, a short length of 2 x 4 should be placed between the motor bracket and the motor leg. The motor leg should then be firmly tied down against the 2 x 4 to prevent any possible damage. Similar precautions should be taken if using the motor as an auxiliary power source for a sailboat or power boat. When using motor as an auxiliary power source, the use of an auxiliary adjustable position motor bracket is recommended.

MAJOR PARTS

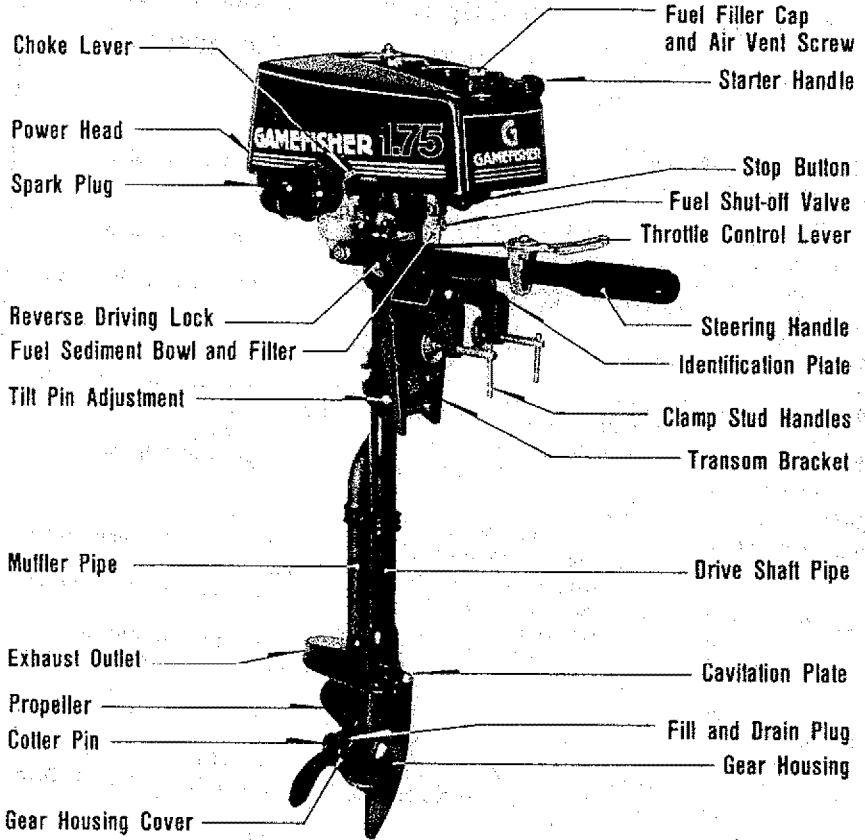

Figure 1

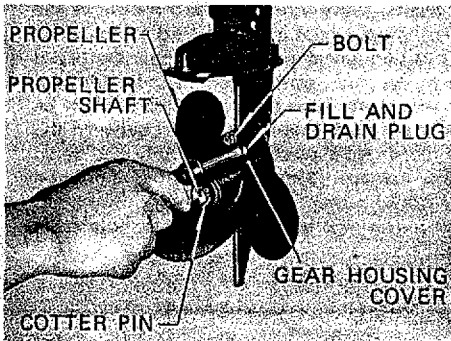

Figure 2

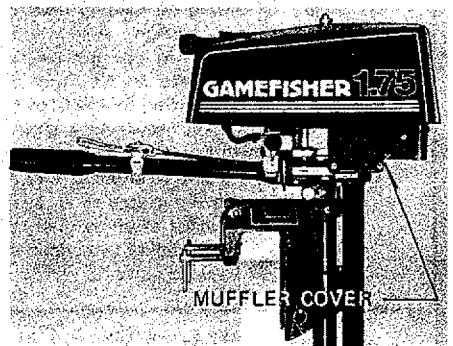

Figure 3

MAINTENANCE

1. FEATURE INFORMATION

- a. This outboard motor has special design features as shown in Figure 1.
- b. Your selection of our Marine Products will provide you with many hours of enjoyable boating. To assure your complete satisfaction on the investment you have just made, we ask you to read this manual thoroughly before going afloat. Acquaint yourself with the particular areas of operation on your outboard motor as you read the step-by-step procedures. Keep in mind maximum performance is achieved only when the owner or operator is completely familiar with the operating instructions.
- c. Periodic servicing will be required. It is recommended that you consult your Sears Service Center when service is necessary. We will be happy to extend our facilities and assure prompt service.

2. LUBRICATION — GEAR HOUSING

- a. The Gear Housing has been pre-lubricated at the factory; however, the grease level should be checked as follows using SAE 90 outboard motor grease. (See Figure 2).
 - (1) Prior to initial operation.
 - (2) After first four (4) hours of use.
 - (3) Recheck after every fifty (50) hours running time.
 - (4) Replace with new lubricant at the end of your outboard motor season. This is important, as it removes any water from the gear housing and prevents possible corrosion to internal parts.
- b. To Check, Drain or Fill gear housing, follow these steps:
 - (1) Position outboard motor upright.
 - (2) Remove drain plug and washer, then insert nozzle of gear lubricant tube into hole.
 - (3) Squeeze tube until lubricant is forced out around tube.
 - (4) Replace plug and washer. Be sure plug is tightened securely.
 - (5) To achieve complete drainage of lubricant, remove cotter pin, propeller and shear pin from propeller shaft, also, gear housing cover by unscrewing 2 bolts.
 - (6) When lubricant has completely drained, replace parts and refill gear housing using filling procedure above.
- c. For best results, lubricate propeller shaft with lithium grease every 30 to 60 days.

3. MUFFLER INSPECTION

- a. Periodically remove muffler cover by unscrewing screws and inspect for carbon build-up inside the muffler inlet and outlet, the exhaust port and the combustion chamber of the cylinder. Excessive carbon will prevent drawing the maximum power out of the engine. (See Figure 3).
- b. Care should be exercised while cleaning away carbon to prevent scratches to the surface of the engine components and dropping carbon inside of crankcase.

4. PROLONGED STORAGE

- a. To store your outboard motor for prolonged storage, prepare outboard as follows:
 - (1) See paragraph on stopping procedures.
 - (2) When removing outboard motor from boat, allow all water to drain from unit.
 - (3) The outboard motor should be mounted on a stand vertically with power head up for storage.
 - (4) Pull starter handle slowly until resistance is felt due to compression pressure, then stop. Release starter tension slowly to prevent engine from reversing rotation due to compression pressure. This position will close both the intake and exhaust ports for storage.
 - (5) Drain and fill gear housing as outlined under Lubrication of Gear Housing.
 - (6) Wipe exterior completely with fresh water cloth and then apply light coating of oil.
- b. When starting a new season, always use fresh gasoline. Last year's gasoline may have varnish deposits that will plug the carburetor jets, thus requiring a complete overhaul.
- c. To plan for the coming season, we recommend you contact your Sears Service Center before the new season for any service repair work required.

OPERATION

5. BOAT MOUNTING

- a. Mount the motor on the center of the boat transom (stern). (See Figure 4).

CAUTION

Hand tighten clamp bracket clamp stud handles simultaneously. Do not use a wrench or any other device that would cause damage to brackets. Occasionally check to be sure clamp stud handles on transom mounting bracket are tight. (See Figure 5).

- b. To obtain the best performance from your outboard, the following boat transom specifications are recommended: (See Figure 4).
Transom Angle (See View 3):
..... 12 to 15 degrees
Transom Height (See View 4):
..... 20.7 inches
- c. The angle of the motor column is easily adjusted by removing the Hitch Pin and changing the Tilt Lock Bracket Pin in the three (3) different angle position holes located on either side of the right or left Transom Mounting Brackets. Each angle position elevates five (5) degrees. Try center hole position first. (See Figure 6).
- d. To find the correct angle position, make a test run at full throttle with your usual loading in the boat. Always stop motor to change the Tilt Lock Bracket Pin. The correct angle position will have your boat traveling with the bow slightly higher than the stern, but should not porpoise (bow rises and falls rapidly and continuously). Be sure Tilt Lock Bracket Pin is always pushed completely through both Transom Mounting Brackets and Hitch Pin is secured.

WARNING

If the motor column is tilted too far outward, the boat is likely to porpoise or cavitate at full throttle, which can be dangerous because a cross wind or a wave could suddenly deflect the boat into a dangerous turn. Also, if the motor column is tilted too far inward, the bow of the boat will dig in, which can be dangerous when crossing a wake or in rough water. Do not run motor in the storage position. (See View 1 and 2, Figure 4).

- e. Secure motor to boat with Safety Chain. Chain not included with motor.

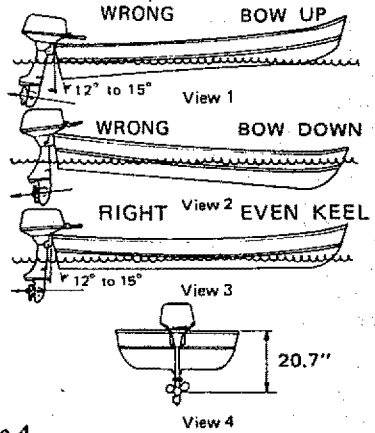

Figure 4

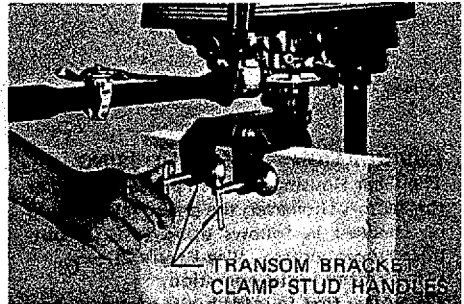

Figure 5

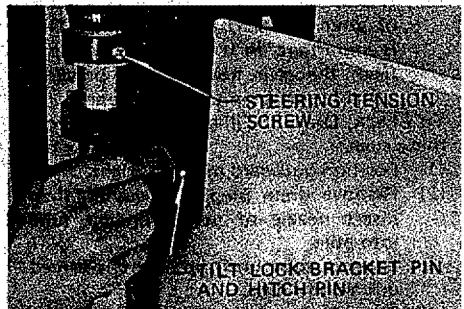

Figure 6

6. STEERING ADJUSTMENT

Tighten steering tension screw using a screwdriver for desired steering effort. (See Figure 6).

CAUTION

There is a possibility of losing screw if backed out too far.

PERATION

2-CYCLE ENGINE FUEL MIXTURE

Use a good grade of regular gasoline. (See mixing table below.)

CAUTION

Always use BIA certified TC-W oil in the 50:1 ratio. Failure to do so may result in excessive spark plug fouling, piston scoring, or bearing failure. Do not under any circumstances, use multigrade, such as 10W-30, or other automobile oils. If BIA certified oil is not available, use an SAE 30 or 40 2-cycle or outboard oil. We reserve the right to refuse warranty on parts which are damaged when using improper fuels or lubricants.

WARNING

Gasoline is highly flammable. Always mix in well ventilated area. Do not fill tank with motor running, nor near any flame or while smoking. Be sure vent screws and filler caps on tanks are finger tightened when transporting gasoline in the trunk of your automobile to prevent explosion.

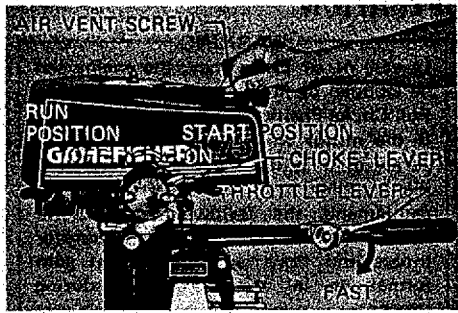

Figure 7

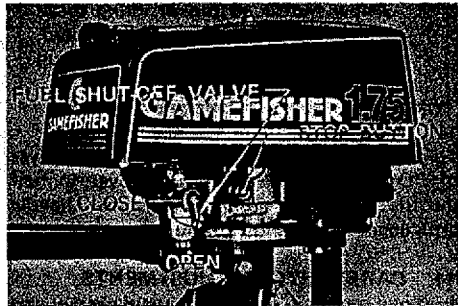

Figure 7A

FUEL MIXING TABLE 50:1 MIXTURE	U.S. Measure		
	Regular Gasoline	Amount of oil to be added	
	In Gallons	In Pints	In Oz
	1	0.16	2.6
	3	0.48	7.7
	5	0.80	12.8
6	0.96	15.4	
Metric Measure			
Regular Gasoline	Amount of oil to be added		
In Liters	In Liters		
1	0.02		
5	0.10		
10	0.20		
20	0.40		

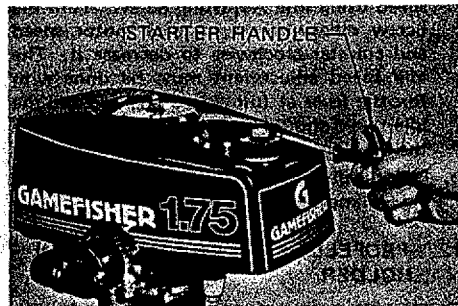

Figure 8

8. STARTING PROCEDURE (See Fig. 7 & 7A)

- Open air vent screw located on fuel filler cap by turning counterclockwise.
- Open fuel shut-off valve.
- Open throttle lever to half throttle.
- Move choke lever to "On" position.

WARNING

When starting outboard, the boat will move with a sudden burst of speed. Make sure you are well seated so as not to lose your balance with a fast start.

- Pull starter handle slowly until you feel starter engage. Then pull with rapid motion and allow the starter cord to retract slowly. (See Figure 8).
- After engine has started, gradually move choke lever to "Off" position while warming up the engine.
- Let engine idle for approximately 3 minutes before moving throttle lever to "Fast" position.

9. STOPPING PROCEDURE

To stop engine, move throttle lever to full "Stop" position and press stop button. (See Figure 7A)

OPERATION

WARNING

In case of an Emergency, the engine can be stopped by moving the Choke Lever to Full Choke Position.

If the motor will not be operated for a period of time, if it is to be removed from the boat, or if it is to be tilted up, we recommend the following practice to prevent spillage from the carburetor throat and bowl and to prevent gum-formations in the carburetor during storage:

1. Close fuel shut-off valve and air vent screw at fuel filler cap.
2. Allow motor to run at idling speed until it stops of its own accord, indicating the carburetor has run dry.

10. FLOODING

To clear engine of excess fuel, move choke lever to "Off" position and throttle lever to half throttle position.. Pull recoil starter handle until engine starts and continues to run.

11. CARBURETOR ADJUSTMENTS

- a. Your motor has a idle adjusting screw and the idle speed has been preset at the factory. However, you may need to adjust the idle speed using Idle Adjusting Screw. Turn the Screw clockwise to increase motor speed and counter clockwise to decrease it. The idle speed adjustment must be done with throttle lever at full closed position and the idle speed should be as low as possible while the engine runs steady. (See Figure 9)
- b. Periodically check filter for dirt by unscrewing Sediment Bowl.

12. PROPELLER SHEAR PIN & CHAIN HOLDER

- a. The Shear Pin is used for the purpose of protecting the Drive Train and Gears. The Shear Pin will not prevent the propeller from becoming damaged when striking an under water object. When shear pin is broken, the engine will continue to run, however, the propeller will not be rotating.

CAUTION

Stop engine immediately after shearing pin to avoid possible damage to the engine.

- b. To replace shear pin, shut off motor, remove cotter pin with pliers and slip off propeller. (See Figures 10 & 11).
- c. Replace with new shear pin located in shear pin and cotter pin holder. (See Figure 12).

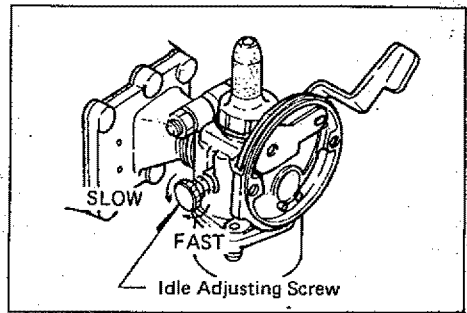

Figure 9

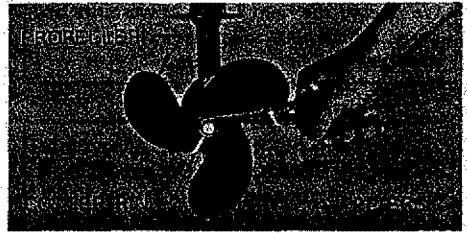

Figure 10

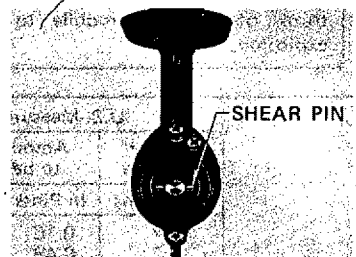

Figure 11

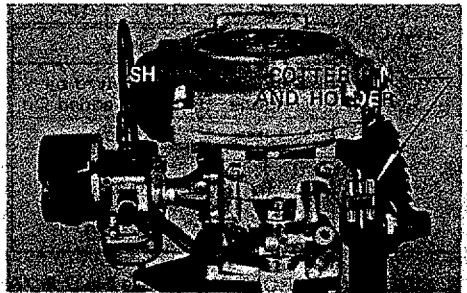

Figure 12

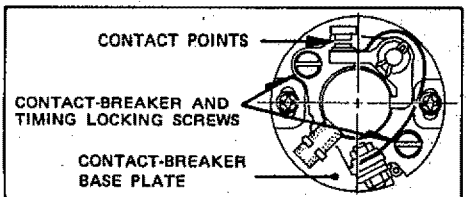

Figure 13

PERATION

3. FLYWHEEL MAGNETO IGNITION SYSTEM

The magneto ignition system consists of the following component parts: Contact Points, Condenser, and Ignition Coil. (See Figure 13).

Inspect the following if engine fails or is hard to start:

- (1) Spark plug as often as necessary. Be sure spark plug gap setting is .025" (0.6mm).
- (2) Gasoline fuel supply and fuel shut-off valve should be open.
- (3) Carburetor being starved of fuel.

The correct spark plug for this motor is Champion RCJ-8.

To test ignition system, remove spark plug and place against bare spot on metal part of motor away from cylinder spark plug hole and then pull starter cord several times. If a spark bridges the plug gap, the magneto is in good operating condition. The high tension lead wire must be connected to the plug for this check. If there is no spark, have the ignition checked at your Sears Service Center.

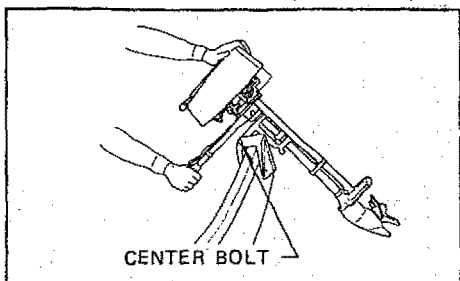

Figure 14

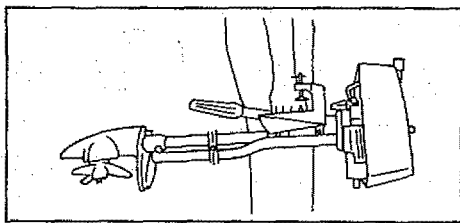

Figure 14A

4. REMOVING MOTOR FROM BOAT

Always tilt motor by lifting on rear of shroud. **DO NOT PUSH DOWN ON THE STEERING HANDLE.** When removing the motor from the boat, raise the outboard in upward direction until the propeller clears the transom. Hold the motor upright long enough to allow all water to drain from the exhaust pipe. When you find it difficult to hold the motor upright, tighten the Center Bolt increasingly for desired effort. (See Figure 14).

WARNING

Although the engine is air cooled, it is possible to burn your hands on the engine block and upper portion of the column. Do not touch.

It may be necessary to rotate the motor to one side before tilting the motor on the transom to remove leg from the water when installed on boats with thick transoms. Always carry outboard with the engine above the lower unit to prevent moisture from entering the engine through the exhaust ports. Steering handle serves as carrying handle as shown in Figure 14A.

WARNING

If the motor will not be operated for a period of time, if it is to be removed from the boat, or if it is to be tilted up, we recommend the following practice to prevent spillage from the carburetor throat and bowl and to prevent gum formations in the carburetor during storage:

1. Close fuel shut-off valve and air vent screw at fuel filler cap.
2. Allow motor to run at idling speed until it stops of its own accord, indicating the carburetor has run dry.

15. SALT WATER OPERATION

To materially increase the life of all exposed parts and decorative finishes, follow the steps indicated below.

- a. Always tilt your motor out of the water when not in use.
- b. Never leave the lower unit in salt water overnight.
- c. Wipe exterior completely with fresh water cloth and then apply light coating of oil.
- d. Lubricate propeller shaft occasionally with a waterproof type of lubricant (Lithium Grease), thus enabling the propeller to be removed easily.
- e. It is good practice when operating in salt water to inspect your motor daily and to apply a light coating of grease to any part or area that shows evidence of corrosion or rust.
- f. Always remove motor from boat vertically, allowing water to drain from column before tilting the motor.

TROUBLE SHOOTING CHECK LIST

Engine Does Not Start	Starts But Does Not Run	Engine Misses	Does Not Idle	Does Not Develop Full Power	
X	X				Fuel Tank Empty
X	X				Fuel Shut-Off Valve Closed
X	X		X	X	Fuel Line Kinked or Pinched
	X		X	X	Fuel Filter Dirty or Clogged
X	X		X	X	Vent Screw on Fuel Tank Filter Cap Closed
X	X		X	X	Carburetor Passages Clogged or Dirty
X	X	X	X	X	Incorrect Fuel-Oil Mixture
X	X	X	X	X	Carburetor Out of Adjustment
X	X				Engine Flooded
X	X	X	X	X	Wrong Type Spark Plug
X	X	X	X	X	Defective or Fouled Spark Plug
X	X	X	X	X	Breaker Contact Points Out of Adjustment
X		X			Defective Magneto
X					Spark Does Not Jump Spark Plug Gap
				X	Engine Out of Time
X	X	X	X	X	Breaker Contact Points Burned or Pitted
X	X	X	X	X	Weak Ignition Coil
X	X	X	X	X	Weak or Defective Condenser
X		X			Spark Plug Lead Wire Not Secured
X		X			Frayed or Cracked Lead Wire Insulation
X		X			Disconnected, Grounded or Loose Wiring in Electrical System
				X	Propeller Bound by Foreign Objects (Fishing Line, Weeds, Etc.)
X					High Tension Lead-Salt Water Build Up

*Take your outboard motor into any one of over 2000 Sears Service Units.

IMPORTANT INFORMATION

MODEL NUMBER: 298.585070

SERIAL NUMBER _____

DATE OF PURCHASE _____

INSURE YOUR ENGINE

Many insurance companies including Allstate Insurance offer protection contracts for your boat and outboard engine. Insurance covering your own equipment against damage, theft, etc., as well as liability insurance for property damage and personal injury to others is available. It would be wise to contact your insurance agent for further information about adequate protection.

IDENTIFICATION PLATE

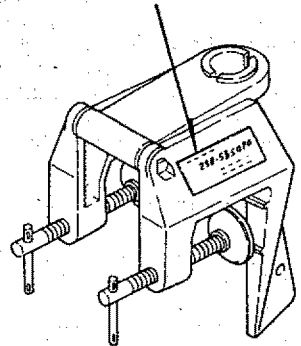

OPERATING LOG

DATE	NO. HRS. USED	GALS. FUEL USED	DATE	NO. HRS. USED	GALS. FUEL USED

REPLACEMENT PARTS

FOR

MODEL No. 298.585070

FIG. 1 ENGINE

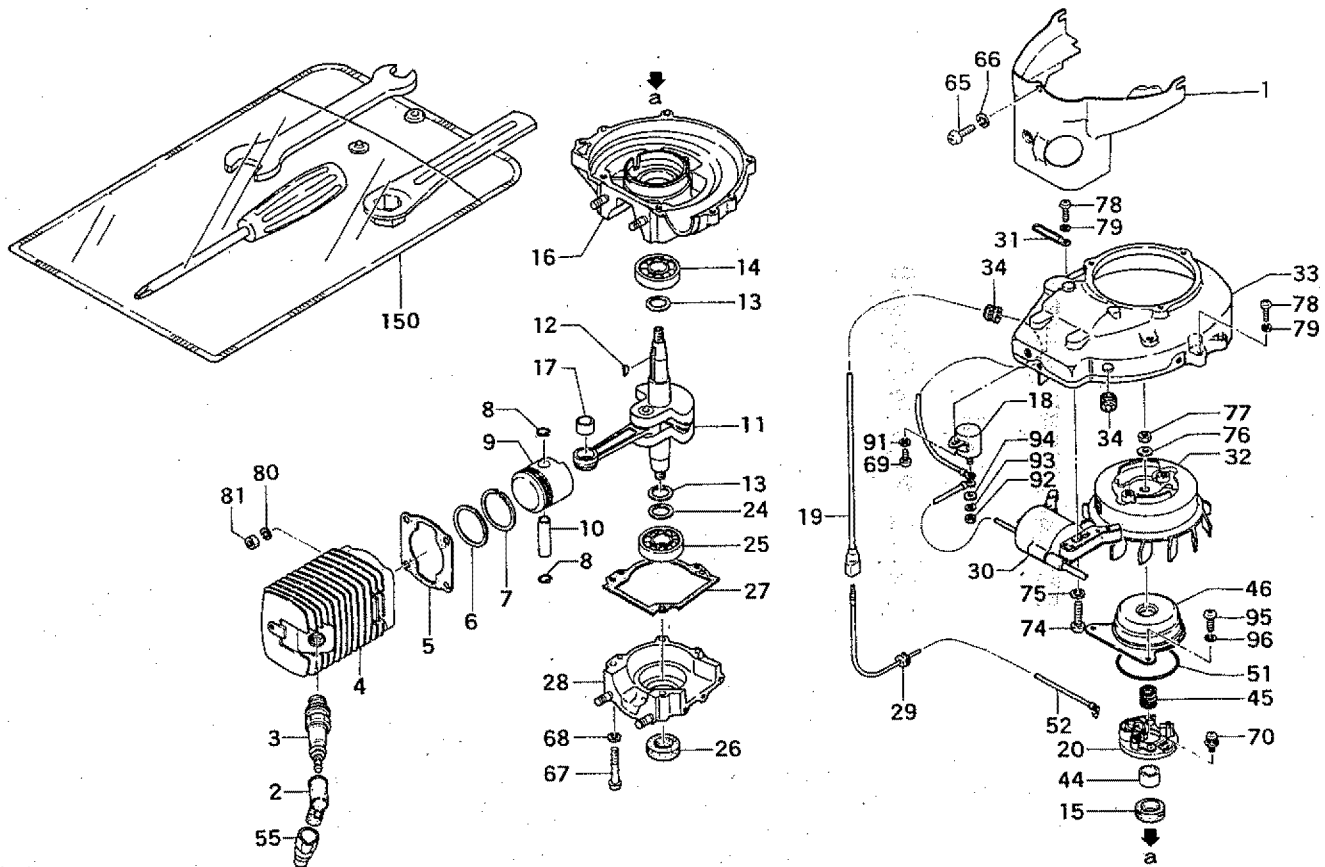

FIG.1 ENGINE

REF. No.	PART No.	PART NAME	Q'ty
1- 1	016-01046-200	CYLINDER SHROUD	1
1- 2	157-04000-900	SPARK PLUG ASS'Y	1
1- 3	018-00562-200	SPARK PLUG RCJ-8	1
1- 4	002-01046-800	CYLINDER COMP	1
1- 5	017-01000-203	CYLINDER GASKET	1
1- 6	040-01000-201	PISTON RING/TOP	1
1- 7	041-01000-201	PISTON RING/LOWER	1
1- 8	039-01000-200	CIR CLIP	2
1- 9	031-01000-200	PISTON	1
1-10	037-01000-200	PISTON PIN	1
1-11	046-01003-804	CRANK SHAFT COMP	1
1-12	068-02000-200	WOOD-RUFF KEY 3 x 13 x 5	1
1-13	070-02401-201	CRANK SHAFT WASHER	2
1-14	999-61620-200	BALL BEARING #6202	1
1-15	999-66152-500	OIL SEAL 15257	1
1-16	076-01000-212	CRANK CASE MAG SIDE COMP	1
1-17	999-62101-004	NEEDLE BEARING #1010	1
1-18	177-20701-801	CONDENSER COMP	1
1-19	173-01046-800	PRIMARY CORD	1
1-20	159-20701-900	CONTACT BREAKER ASS'Y	1
1-24	071-02007-200	CRANK SHAFT SHIM 0.05	1
	071-02007-210	CRANK SHAFT SHIM 0.10	1
	071-02007-220	CRANK SHAFT SHIM 0.15	1
	071-02007-230	CRANK SHAFT SHIM 0.20	1
	071-02007-240	CRANK SHAFT SHIM 0.30	1
1-25	999-61620-200	BALL BEARING #6202	1
1-26	999-66152-500	OIL SEAL #15257	1
1-27	090-01000-200	CRANK CASE GASKET	1
1-28	076-01000-212	CRANK CASE DRIVE SIDE	1
1-29	203-01000-201	PRIMARY CORD GROMMET	1
1-30	167-20753-800	IGNITION COIL COMP	1
1-31	198-01046-900	CORD SUPPORT ASS'Y	1
1-32	155-20750-800	MAGNETO ROTOR COMP	1
1-33	112-01046-200	FAN CASE	1
1-34	202-01003-201	SECONDARY CORD GROMMET	2
1-44	246-20701-201	MAGNETO CAM	1
1-45	247-01000-201	CAM SUPPORT SPRING	1
1-46	191-01046-200	POINT COVER	1
1-51	999-67045-000	O-RING G-45	1
1-52	173-20701-802	PRIMARY CORD	1
1-55	256-01046-200	SPARK PLUG RUBBER COVER B	1
1-65	990-11050-102	SCREW 5 x 10	4
1-66	992-10050-041	WASHER 5	4
1-67	990-11050-382	SCREW 5 x 38	4
1-68	992-10050-042	S. WASHER 5	4
1-69	990-11040-061	SCREW 4 x 6	1
1-70	994-15040-101	SCREW 4 x 10/P.S	2
1-74	990-11050-202	SCREW 5 x 20	2
1-75	992-10050-042	S. WASHER 5	2
1-76	065-00000-200	FLYWHEEL WASHER	1
1-77	066-00000-200	FLYWHEEL NUT	1
1-78	990-11050-202	SCREW 5 x 20	4
1-79	992-10050-042	S. WASHER 5	4
1-80	992-10060-042	S. WASHER 6	4

FIG. 1 ENGINE

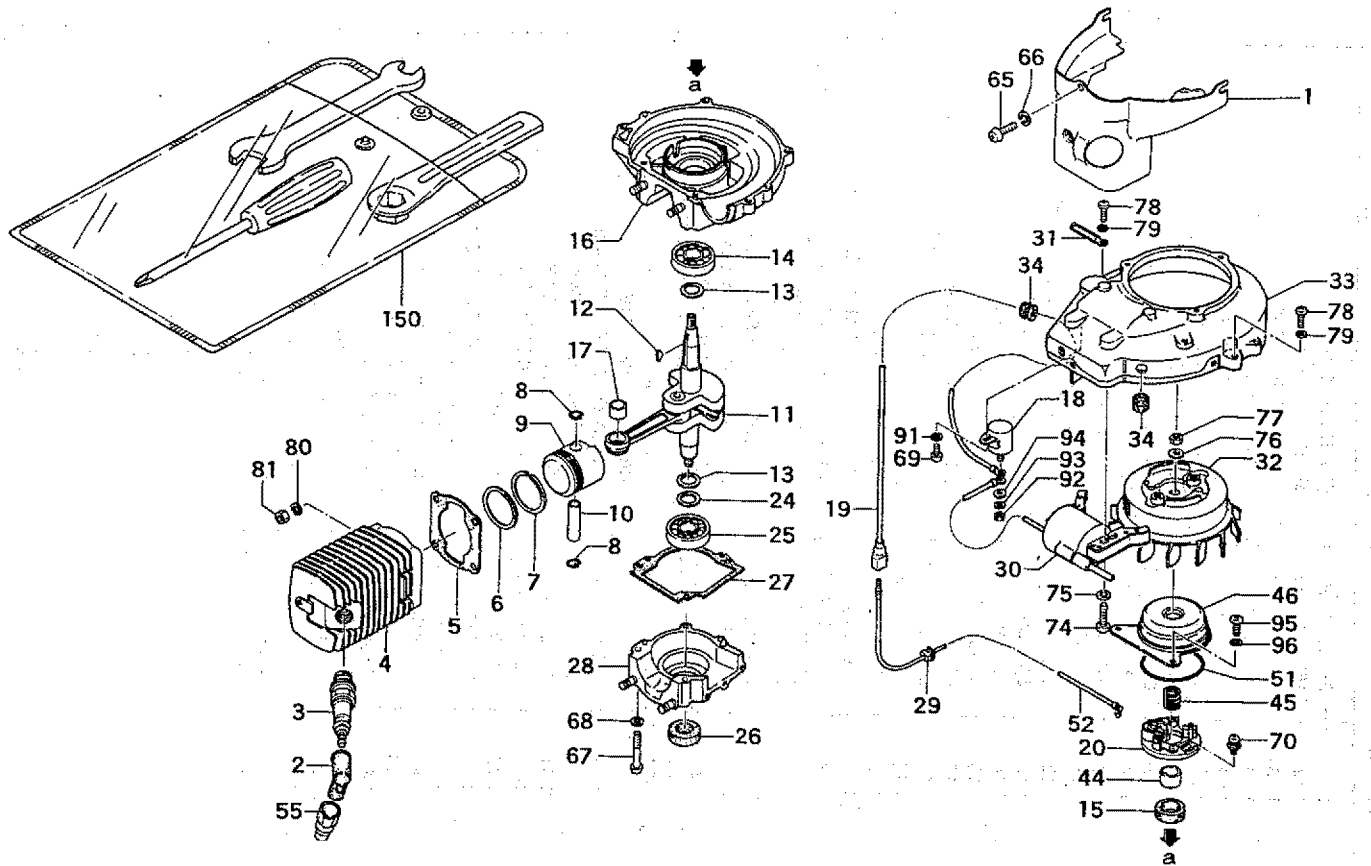

FIG.1 ENGINE

REF. No.	PART No.	PART NAME	Q'ty
1-81	991-01060-021	NUT 6	4
1-91	992-10040-012	S. WASHER 4	1
1-92	991-01030-011	NUT 3	1
1-93	992-10030-012	S. WASHER 3	1
1-94	992-01030-011	WASHER 3	1
1-95	990-11040-102	SCREW 4 x 10	3
1-96	992-10040-042	S. WASHER 4	3
1-150	985-35306-900	TOOL KIT	1

FIG. 2 TANK & MUFFLER

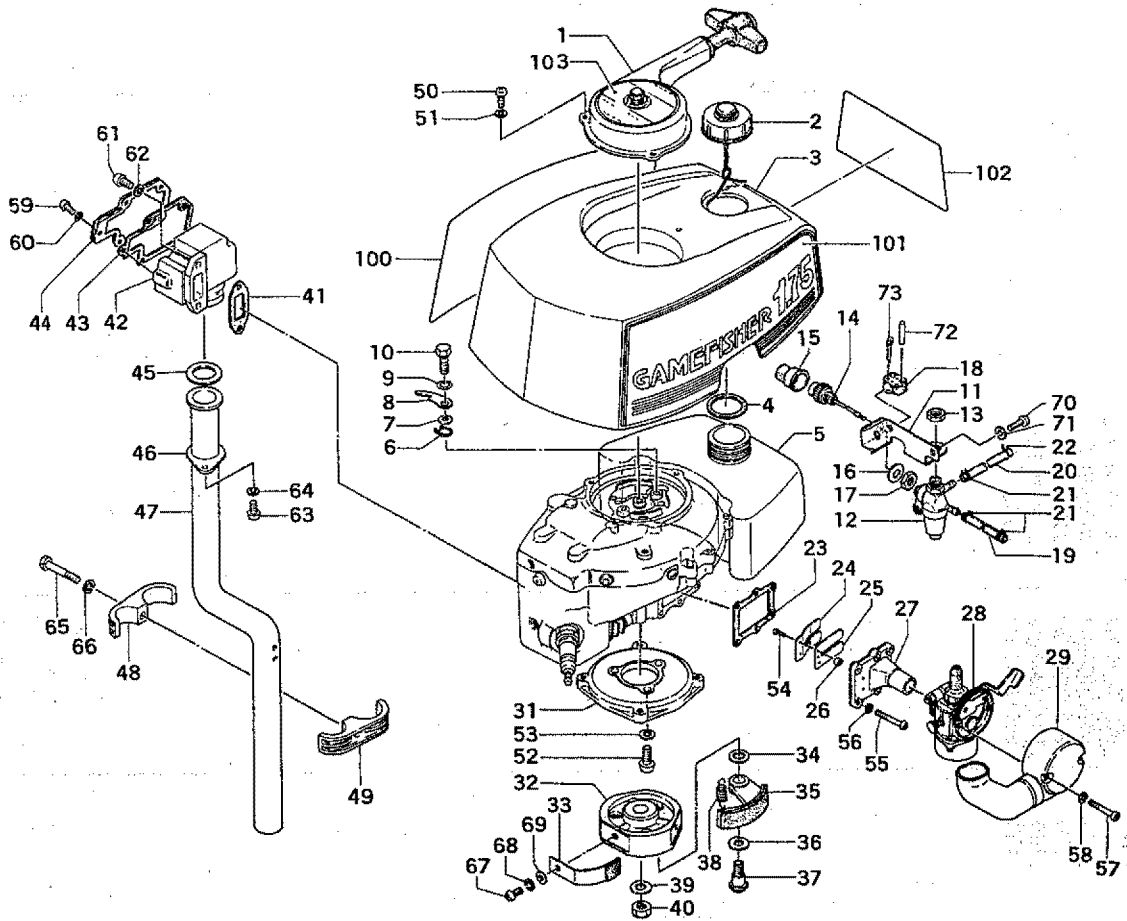

FIG.2 TANK & MUFFLER

REF. No.	PART No.	PART NAME	Q'ty
2- 1	756-00537-900	RECOIL STARTER ASS'Y	1
2- 2	595-35100-902	TANK CAP ASS'Y	1
2- 3	300-35306-200	ENGINE COVER	1
2- 4	600-35100-203	TANK SUPPORT RING	1
2- 5	401-35300-200	TANK	1
2- 6	790-00601-202	STARTER PAWL SPRING	2
2- 7	992-01050-011	WASHER 5	2
2- 8	788-00601-203	STARTER PAWL	2
2- 9	822-00601-200	STARTER PAWL SHIM	2
2-10	793-10200-200	STEP BOLT	2
2-11	662-01046-200	COCK HOLDING METAL	1
2-12	592-10201-900	COCK ASS'Y	1
2-13	594-00517-200	COCK NUT	1
2-14	170-01046-800	STOP BUTTON	1
2-15	266-00503-202	STOP BUTTON COVER	1
2-16	181-01004-200	SPECIAL SPRING WASHER	1
2-17	180-01004-200	STOP BUTTON FIXING NUT	1
2-18	021-35100-201	PIN HOLDER	1
2-19	700-14508-068	FUEL PIPE	1
2-20	700-14508-050	FUEL PIPE	1
2-21	680-01004-200	CLIP $\phi 8$	3
2-22	701-00517-200	FUEL PIPE STOPPER	1
2-23	398-01000-202	LEAD VALVE SEAT GASKET	1
2-24	395-01225-200	LEAD HOLDING METAL	1
2-25	394-01202-201	LEAD VALVE	1
2-26	399-01000-200	LEAD VALVE COLLAR	2
2-27	390-01046-200	LEAD VALVE SEAT	1
2-28	455-22907-901	CARBURETOR ASS'Y	1
2-29	424-10201-200	CLEANER CAP	1
2-30	437-10201-200	CLEANER JOINT	1
2-31	333-01046-200	CLUTCH HOLDING BASE	1
2-41	737-01000-201	MUFFLER GASKET	1
2-42	716-01046-200	MUFFLER BODY A	1
2-43	737-01046-200	MUFFLER GASKET	1
2-44	717-01046-200	MUFFLER BODY B	1
2-45	221-35500-200	MUFFLER PIPE GASKET	1
2-46	226-35500-200	MUFFLER PIPE STAY A	1
2-47	220-35300-200	MUFFLER PIPE	1
2-48	225-35500-200	MUFFLER PIPE STAY	1
2-49	227-35500-200	MUFFLER PIPE STAY B	1
2-50	990-11040-252	SCREW 4 x 25	3
2-51	992-10040-042	S. WASHER 4	3
2-52	990-11060-162	SCREW 6 x 16	3
2-53	992-10060-042	S. WASHER 6	3
2-54	990-11030-101	SCREW 3 x 10	2
2-55	990-11040-162	SCREW 4 x 16	6
2-56	992-10040-042	S. WASHER 4	6
2-57	990-11040-302	SCREW 4 x 30	2
2-58	992-10040-042	S. WASHER 4	2
2-59	990-11040-122	SCREW 4 x 12	5
2-60	992-10040-042	S. WASHER 4	5
2-61	990-11060-202	SCREW 6 x 20	2
2-62	992-10060-042	S. WASHER 6	2
2-63	990-11050-122	SCREW 5 x 12	2

FIG. 2 TANK & MUFFLER

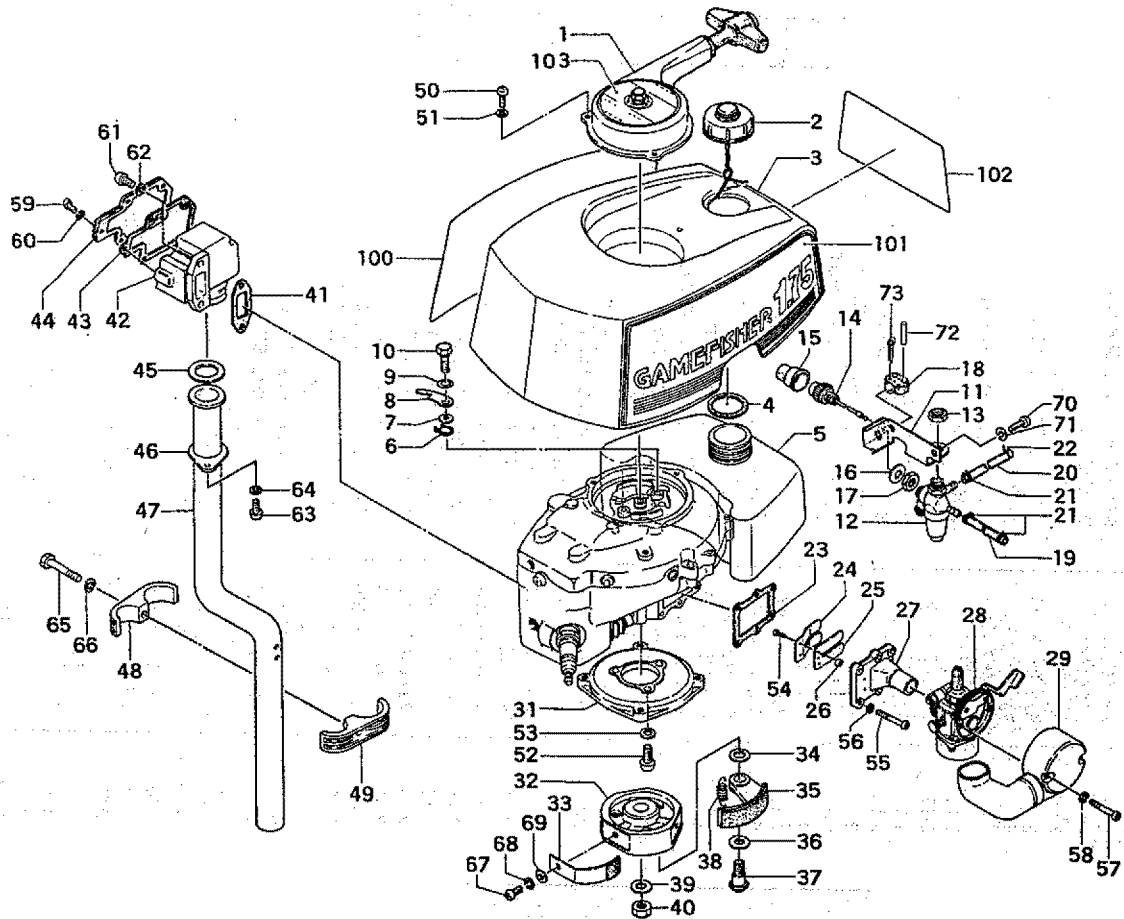
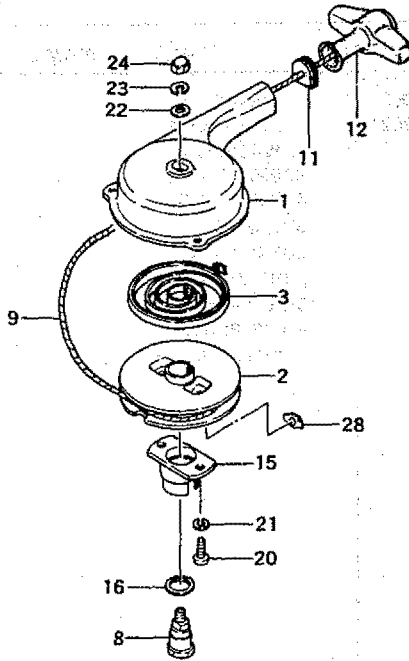

FIG.2 TANK & MUFFLER

REF. No.	PART No.	PART NAME	Q'ty
2-64	992-10050-042	S. WASHER 5	2
2-65	990-11060-252	SCREW 6 x 25	1
2-66	992-10060-042	S. WASHER 6	1
2-70	990-11060-122	SCREW 6 x 12	2
2-71	992-10060-042	S. WASHER 6	2
2-72	012-35500-200	SHEAR PIN	2
2-73	011-35100-200	COTTER PIN	2
2-100	330-35351-200	SIDE MARK RIGHT	1
2-101	331-35351-200	SIDE MARK LEFT	1
2-102	906-35306-200	NAME PLATE	1
2-103	336-35118-200	STARTER MARK	1

G.3 RECOIL STARTER



EF. No.	PART No.	PART NAME	Q'ty
3- 0-1	756-00537-900	RECOIL STARTER ASS'Y	1
3- 1	772-00537-200	* RECOIL STARTER BODY	1
3- 2	774-04015-204	* STARTER PULLEY	1
3- 3	779-01006-201	* RECOIL SPRING	1
3- 8	776-01006-207	* PULLEY SHAFT	1
3- 9	783-00517-200	* ROPE	1
3-11	780-00601-201	* HANDLE GUIDE	1
3-12	785-10207-901	* STARTER HANDLE ASS'Y	1
3-15	773-00100-204	* PULLEY SHAFT OUTER	1
3-16	814-00500-200	* STARTER PULLEY SHIM	1
3-20	990-11050-122	* SCREW 5 x 12	2
3-21	992-10050-042	* S. WASHER 5	2
3-22	992-01060-041	* WASHER 6	1
3-23	992-10060-042	* S. WASHER 6	1
3-24	991-41060-022	* BLIND NUT 6	1
3-28	782-00546-200	* ROPE RECEIVE	1

FIG.4 CARBURETOR

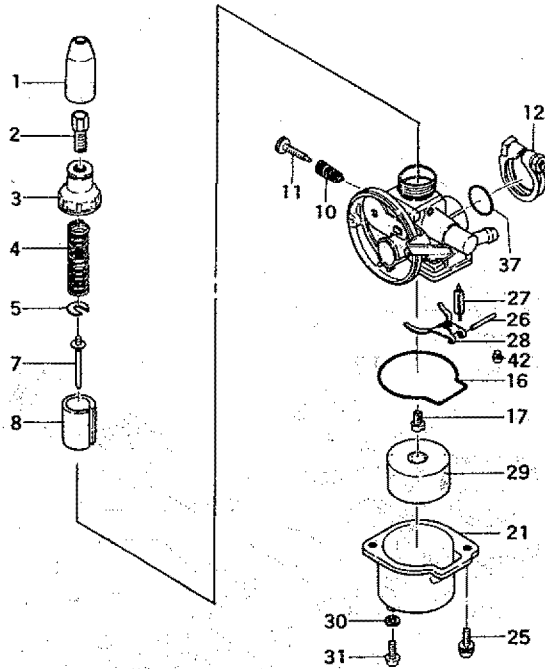

REF. No.	PART No.	PART NAME	Q'ty
4- 0-1	455-22907-901	CARBURETOR ASS'Y	1
4- 1	560-22902-202	* RUBBER CAP	1
4- 2	597-22602-200	* CABLE ADJUSTER	1
4- 3	595-22900-200	* BODY CAP	1
4- 4	594-22602-200	* THROTTLE VALVE SPRING	1
4- 5	619-22602-200	* THROTTLE SPRING SEAT	1
4- 7	592-22907-910	* JET NEEDLE ASS'Y	1
4- 8	591-22907-200	* THROTTLE VALVE	1
4-10	623-22900-200	* ADJUSTER SPRING	1
4-11	622-22907-200	* ADJUSTER SCREW	1
4-12	561-22900-900	* BODY BAND ASS'Y	1
4-16	607-22900-200	* CHAMBER GASKET	1
4-17	599-22907-200	* MAIN JET	1
4-21	606-22900-200	* FLOAT CHAMBER	1
4-25	994-34040-121	* SCREW 4 x 12/S	2
4-26	605-22900-200	* FLOAT ARM PIN	1
4-27	603-22900-800	* NEEDLE VALVE	1
4-28	628-22900-200	* FLOAT ARM	1
4-29	604-22903-200	* FLOAT	1
4-30	629-22900-200	* DRAIN GASKET	1
4-31	994-31040-061	* SCREW 4 x 6	1
4-37	570-22903-200	* GASKET	1
4-42	990-11040-061	* SCREW 4 x 6	1

3.5 HANDLE & BRACKET

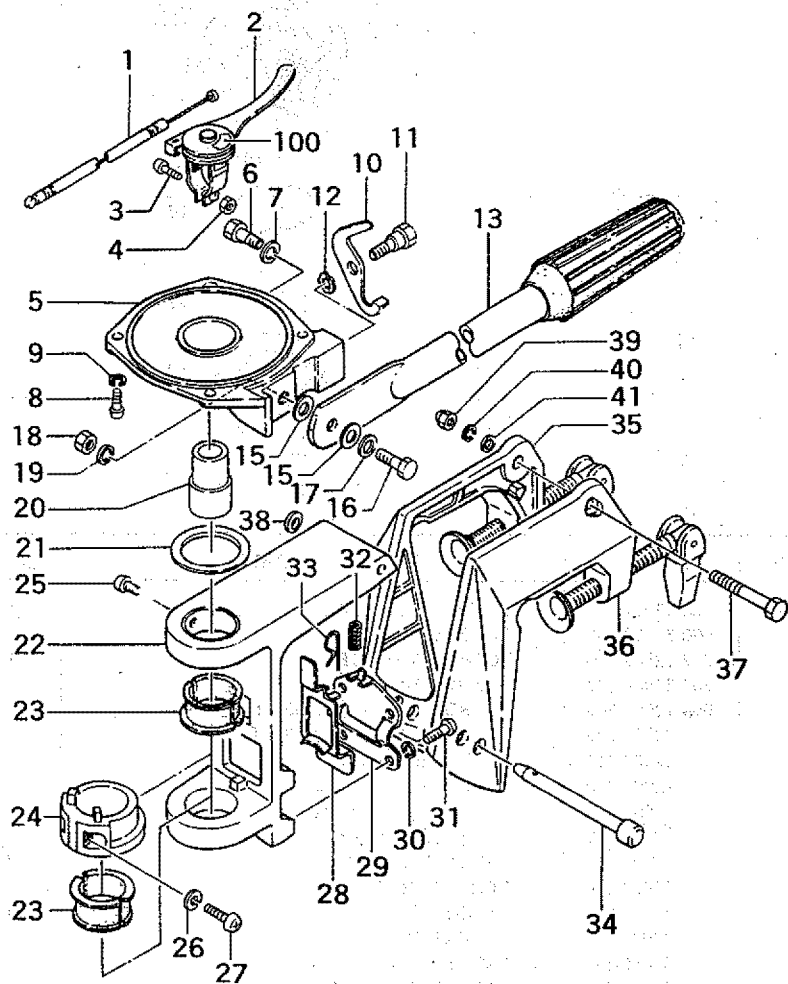

FIG.5 HANDLE & BRACKET

REF. No.	PART No.	PART NAME	Q'ty
5- 1	885-01046-800	THROTTLE WIRE COMP	1
5- 2	870-00005-930	THROTTLE LEVER ASS'Y	1
5- 3	990-11050-252	SCREW 5 x 25	1
5- 4	991-01050-021	NUT 5	1
5- 5	145-35500-202	JOINT PIPE HOLDER	1
5- 6	990-21080-402	BOLT 8 x 40	1
5- 7	992-10080-042	S. WASHER 8	1
5- 8	990-11050-202	SCREW 5 x 20	4
5- 9	992-10050-042	S. WASHER 5	4
5-10	161-35500-202	HANDLE STOPPER	1
5-11	793-10200-200	STEP BOLT	1
5-12	992-04060-050	WAVE WASHER 6	1
5-13	160-35500-900	HANDLE, STEERING, ASS'Y	1
5-15	162-35500-200	HANDLE WASHER	2
5-16	990-21080-302	BOLT 8 x 30	1
5-17	992-01080-041	WASHER 8	1
5-18	991-01080-021	NUT 8	1
5-19	992-10080-042	S. WASHER 8	1
5-20	079-35350-800	ADAPTER COMP.	1
5-21	134-35500-201	THRUST WASHER	1
5-22	115-35500-204	BRACKET	1
5-23	131-35306-200	THRUST BRACKET	4
5-24	136-35500-200	RETURN CAM	1
5-25	990-11060-102	SCREW 6 x 10	1
5-26	992-10050-042	S. WASHER 5	1
5-27	990-11050-162	SCREW 5 x 16	1
5-28	137-35500-201	RETURN CAM GUIDE	1
5-29	138-35500-201	RETURN GUIDE PLATE	1
5-30	992-10050-042	S. WASHER 5	4
5-31	990-11050-122	SCREW 5 x 12	4
5-32	139-35500-200	RETURN SPRING	1
5-33	129-35100-200	BRACKET PIN STOPPER A	1
5-34	123-35500-201	BRACKET PIN S	1
5-35	107-35119-800	CLAMP BRACKET B COMP.	1
5-36	106-35119-800	CLAMP BRACKET A COMP.	1
5-37	990-21060-732	BOLT 6 x 73	1
5-38	108-35501-200	CLAMP BRACKET BUSHING	2
5-39	991-41060-022	CAP NUT 6	1
5-40	992-10060-042	S. WASHER 6	1
5-41	992-01060-041	WASHER 6	1
5-100	910-01046-200	LEVER MARK	1

FIG. 6 DRIVE SHAFT PIPE & GEAR CASE

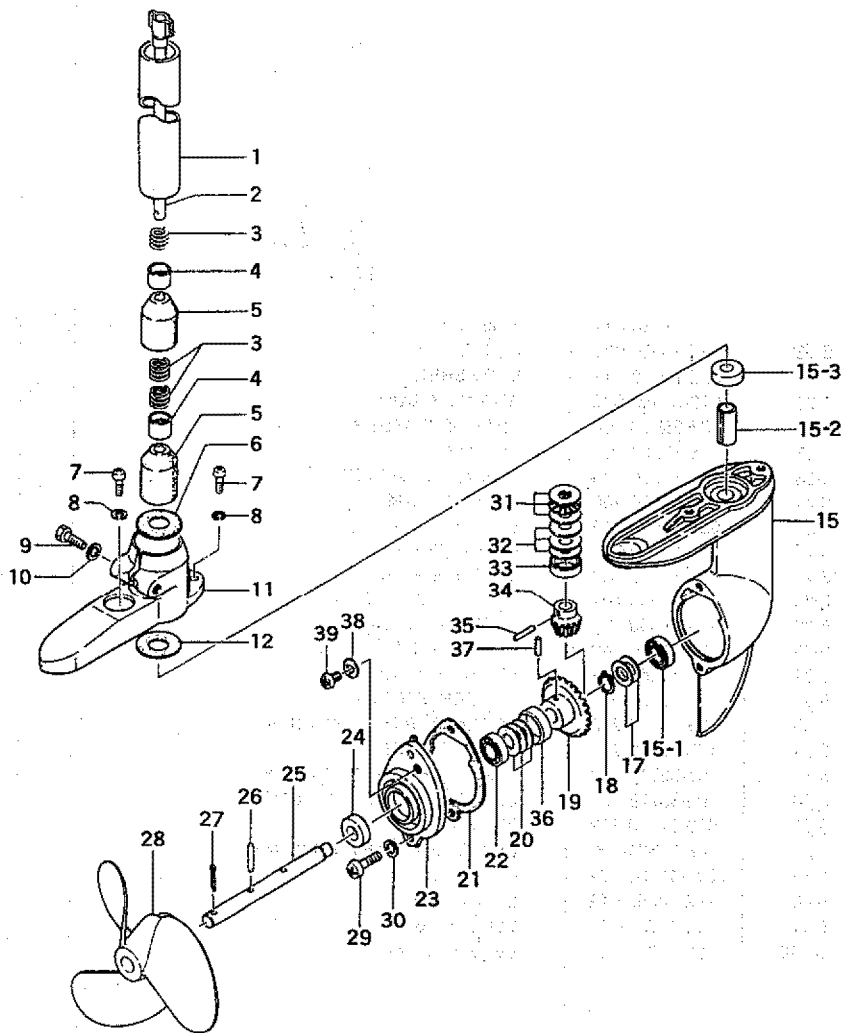

FIG.6 DRIVE SHAFT PIPE & GEAR CASE

REF. No.	PART No.	PART NAME	Q'ty
6- 1	090-35351-200	DRIVE SHAFT PIPE	1
6- 2	075-35500-800	DRIVE SHAFT COMP	1
6- 3	086-35500-200	BEARING HOLDER CLIP	3
6- 4	999-62101-521	NEEDLE BEARING 1015	2
6- 5	039-35500-200	BEARING HOLDER	2
6- 6	091-35500-200	DRIVE SHAFT PIPE GASKET	1
6- 7	990-21080-402	BOLT 8 x 40	1
6- 8	992-10080-042	S. WASHER 8	1
6- 9	990-21080-402	BOLT 8 x 40	1
6-10	992-10080-042	S. WASHER 8	1
6-11	034-35500-200	GEAR CASE HOLDER	1
6-12	091-35500-200	DRIVE SHAFT PIPE GASKET	2
6-15	031-35500-900	GEAR CASE ASS'Y	1
6-15-1	999-61600-000	* BALL BEARING #6000	1
6-15-2	032-35500-210	* PLANT BEARING L	1
6-15-3	999-66102-200	* OIL SEAL 10228	1
6-17	171-35500-201	PROPELLER SHAFT SHIM A 0.10	1
	173-35500-200	PROPELLER SHAFT SHIM A 0.20	1
	174-35500-200	PROPELLER SHAFT SHIM A 0.30	1
	175-35500-200	PROPELLER SHAFT SHIM A 1.0	1
6-18	013-35500-200	STOP RING	1
6-19	017-36120-200	GEAR	1
6-20	330-00200-210	GEAR SHAFT SHIM 0.1	1
	330-00200-230	GEAR SHAFT SHIM 0.2	1
	330-00200-240	GEAR SHAFT SHIM 0.3	1
6-21	048-35500-202	GEAR CASE GASKET	1
6-22	999-61600-100	BALL BEARING #6001	1
6-23	046-35500-200	GEAR CASE COVER COMP	1
6-24	999-66122-266	OIL SEAL 12227	1
6-25	019-35500-201	PROPELLER SHAFT	1
6-26	012-35500-200	SHEAR PIN	3
6-27	011-35100-200	COTTER PIN	3
6-28	010-35306-200	PROPELLER	1
6-29	990-11060-182	SCREW 6 x 18	2
6-30	992-11060-042	S. WASHER 6	2
6-31	999-62102-463	THRUST BEARING 1024	1
6-32	063-35500-200	DRIVE SHAFT SHIM 0.50	1
	064-35500-200	DRIVE SHAFT SHIM 0.10	1
	066-35500-200	DRIVE SHAFT SHIM 0.20	1
6-33	062-35500-200	PINION COLLAR	1
6-34	060-35300-200	PINION	1
6-35	061-35500-200	PINION PIN 4 x 16	1
6-36	026-35500-200	GEAR COLLAR	1
6-37	025-35500-200	GEAR PIN	1
6-38	317-02000-200	GROMMET GASKET	1
6-39	990-11060-082	SCREW 6 x 8	1

MODEL NO.
298.585070

Sears

GAMEFISHER[®]

OUTBOARD MOTOR 1.75 H.P.

OWNER'S
MANUAL

For quick service or repair, take your Outboard Motor to any Sears Service Unit throughout the U.S. and Canada. Each Service Unit is staffed by trained technicians, using Sears approved parts and repair procedures to ensure that we meet our pledge to you—"We service what we sell." Refer to the local telephone directory for the Sears Unit nearest you.

HOW TO ORDER REPAIR PARTS

Refer to the Identification Plate for the complete model number when requesting service or replacement parts for your outboard motor.

All parts listed herein may be ordered from any Sears, Roebuck and Co.

WHEN ORDERING REPAIR PARTS, ALWAYS GIVE THE FOLLOWING INFORMATION:

1. Model Number
2. Part Number
3. Part Name
4. Quantity

If the parts you need are not stocked locally, your order will be electronically transmitted to a Sears Repair Parts Distribution Center for expedited handling.

FULL ONE YEAR WARRANTY ON OUTBOARD MOTOR

For one year from the first day of use of this outboard motor, when all instructions and procedures detailed in the Owner's Manual are followed, Sears will repair defects in material or workmanship which appear in the outboard motor, free of charge.

If the outboard motor is used for commercial or rental purposes, this warranty applies for only thirty days from the first day of use.

Warranty Service is available by simply returning the outboard motor to the nearest Sears store in the United States or Canada. Warranty is valid in country of purchase.

This warranty gives you specific legal rights, and you may also have other rights which vary from state to state.

SEARS, ROEBUCK AND CO.

Sears Tower BSC 41-3 Chicago, IL 60684

SIMPSONS-SEARS LIMITED

222 Jarvis St.

Toronto, Ontario, Canada