

Operator's Manual

CRAFTSMAN®

6 in. Electric Sander/Polisher Double Insulated

Model No.

315.115070

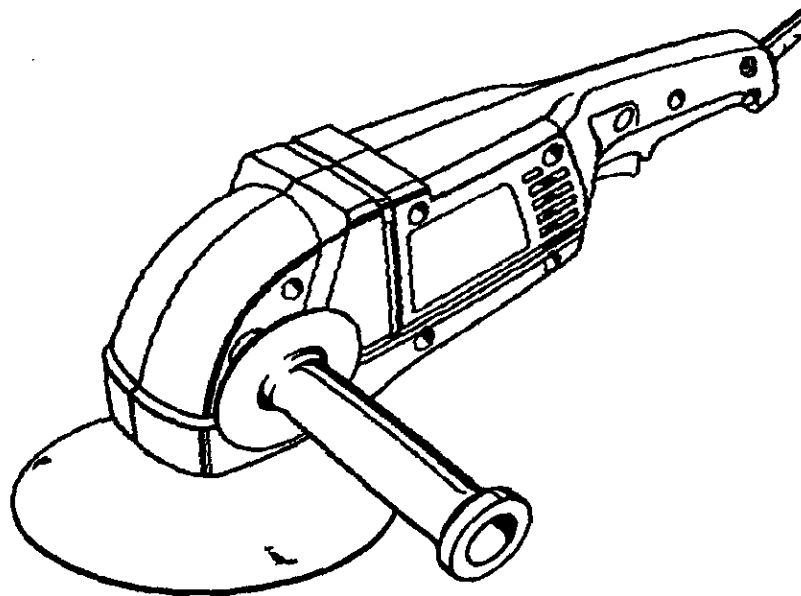

Save this manual for
future reference.

⚠ CAUTION: Read and follow
all Safety Rules and Operating
Instructions before first use of
this product.

Customer Help Line: 1-800-932-3188

Sears, Roebuck and Co., 3333 Beverly Rd., Hoffman Estates, IL 60179 USA
Visit the Craftsman web page: www.sears.com/craftsman

972000-990
9-02

- Safety
- Warranty
- Introduction
- Operation
- Maintenance
- Parts List



TABLE OF CONTENTS

- Table of Contents / Warranty / Introduction 2
- General Safety Rules 3-4
- Specific Safety Rules 4
- Symbols 5
- Product Specifications 6
- Operation 6-10
- Maintenance 11
- Accessories 11
- Exploded View and Repair Parts List 12-13
- Parts Ordering / Service 14

WARRANTY

FULL ONE YEAR WARRANTY ON CRAFTSMAN SANDER/POLISHER

If this **CRAFTSMAN** Sander/Polisher fails to give complete satisfaction within one year from the date of purchase, **RETURN IT TO THE NEAREST SEARS STORE OR SEARS SERVICE CENTER IN THE UNITED STATES**, and Sears will replace it, free of charge.

If this **CRAFTSMAN** Sander/Polisher is used for commercial or rental purposes, this warranty applies for only 90 days from the date of purchase.

This warranty gives you specific legal rights, and you may also have other rights which vary from state to state.

Sears, Roebuck and Co., Dept. 817WA, Hoffman Estates, IL 60179

INTRODUCTION

Congratulations and thank you for buying this Craftsman 6 inch Electric Sander/Polisher. Your tool has been designed, engineered and manufactured to provide you with Sears high standard of dependability, ease of operation, and operator safety. Properly cared for it will give you years of rugged, trouble-free performance.

Your sander/polisher has many features for making your sanding/polishing operations more pleasant and enjoyable. Safety, performance and dependability have been given top priority in the design of this tool making it easy to maintain and operate.

CAUTION: Carefully read through this entire operator's manual before using your new sander/polisher. Pay close attention to the Rules for Safe Operation, Warnings and Cautions. If you use this tool properly and only for what it is intended, you will enjoy years of safe, reliable service.



Look for this symbol to point out important safety precautions. It means attention!!! Your safety is involved.



WARNING:



The operation of any sander/polisher can result in foreign objects being thrown into your eyes, which can result in severe eye damage. Before beginning power tool operation, always wear safety goggles or safety glasses with side shields and a full face shield when needed. We recommend Wide Vision Safety Mask for use over eyeglasses or standard safety glasses with side shields, available at Sears Retail Stores. Always wear eye protection which is marked to comply with ANSI Z87.1.

GENERAL SAFETY RULES

⚠ WARNING: Read and understand all instructions. Failure to follow all instructions listed below may result in electric shock, fire and/or serious personal injury.

SAVE THESE INSTRUCTIONS

Work Area

- **Keep your work area clean and well lit.** Cluttered benches and dark areas invite accidents.
- **Do not operate power tools in explosive atmospheres, such as in the presence of flammable liquids, gases, or dust.** Power tools may create sparks which may ignite the dust or fumes.
- **Keep bystanders, children, and visitors away while operating a power tool.** Distractions can cause you to lose control.

Electrical Safety

- **Double insulated tools are equipped with a polarized plug (one blade is wider than the other). This plug will fit in a polarized outlet only one way. If the plug does not fit fully in the outlet, reverse the plug. If it still does not fit, contact a qualified electrician to install a polarized outlet. Do not change the plug in any way.** Double insulation  eliminates the need for the three-wire grounded power cord and grounded power supply system.
- **Avoid body contact with grounded surfaces, such as pipes, radiators, ranges, and refrigerators.** There is an increased risk of electric shock if your body is grounded.
- **Don't expose power tools to rain or wet conditions.** Water entering a power tool will increase the risk of electric shock.
- **Do not abuse the cord. Never use the cord to carry the tools or pull the plug from an outlet. Keep cord away from heat, oil, sharp edges, or moving parts. Replace damaged cords immediately. Damaged cords increase the risk of electric shock.**
- **When operating a power tool outside, use an outdoor extension cord marked "W-A" or "W".** These cords are rated for outdoor use and reduce the risk of electric shock.

Personal Safety

- **Stay alert, watch what you are doing and use common sense when operating a power tool. Do not use tool while tired or under the influence of drugs, alcohol, or medication.** A moment of inattention while operating power tools may result in serious personal injury.

- **Dress properly. Do not wear loose clothing or jewelry. Contain long hair. Keep your hair, clothing, and gloves away from moving parts.** Loose clothes, jewelry, or long hair can be caught in moving parts.
- **Avoid accidental starting. Be sure switch is off before plugging in.** Carrying tools with your finger on the switch or plugging in tools that have the switch on invites accidents.
- **Remove adjusting keys or wrenches before turning the tool on.** A wrench or a key that is left attached to a rotating part of the tool may result in personal injury.
- **Do not overreach. Keep proper footing and balance at all times.** Proper footing and balance enables better control of the tool in unexpected situations.
- **Use safety equipment. Always wear eye protection. Dust mask, non-skid safety shoes, hard hat, or hearing protection must be used for appropriate conditions.**

Tool Use and Care

- **Use clamps or other practical way to secure and support the workpiece to a stable platform.** Holding the work by hand or against your body is unstable and may lead to loss of control.
- **Do not force tool. Use the correct tool for your application.** The correct tool will do the job better and safer at the rate for which it is designed.
- **Do not use tool if switch does not turn it on or off.** Any tool that cannot be controlled with the switch is dangerous and must be repaired.
- **Disconnect the plug from power source before making any adjustments, changing accessories, or storing the tool.** Such preventive safety measures reduce the risk of starting the tool accidentally.
- **Store idle tools out of the reach of children and other untrained persons.** Tools are dangerous in the hands of untrained users.
- **Maintain tools with care. Keep cutting tools sharp and clean.** Properly maintained tools with sharp cutting edges are less likely to bind and are easier to control.
- **Check for misalignment or binding of moving parts, breakage of parts, and any other condition that may affect the tool's operation. If damaged, have the tool serviced before using.** Many accidents are caused by poorly maintained tools.
- **Use only accessories that are recommended by the manufacturer for your model.** Accessories that may be suitable for one tool, may become hazardous when used on another tool.

GENERAL SAFETY RULES

Service

- **Tool service must be performed only by qualified repair personnel.** Service or maintenance performed by unqualified personnel could result in a risk of injury.
- **When servicing a tool, use only identical replacement parts.** Follow instructions in the **Maintenance section** of this manual. Use of unauthorized parts or failure to follow Maintenance Instructions may create a risk of electric shock or injury.



SPECIFIC SAFETY RULES

- **Hold tool by insulated gripping surfaces when performing an operation where the tool may contact hidden wiring or its cord.** Contact with a "live" wire will make exposed metal parts of the tool "live" and shock the operator.
- **Accessories must be rated for at least the speed recommended on the tool warning label.** Wheels and other accessories running over rated speed can fly apart and cause injury.

Additional Rules For Safe Operation





- **Know your power tool.** Read operator's manual carefully. Learn its applications and limitations, as well as the specific potential hazards related to this tool. Following this rule will reduce the risk of electric shock, fire, or serious injury.
 - **Always wear safety glasses.** Everyday eye-glasses have only impact-resistant lenses; they are NOT safety glasses. Following this rule will reduce the risk of serious personal injury.
 - **Protect your lungs.** Wear a face or dust mask if the operation is dusty. Following this rule will reduce the risk of serious personal injury.
 - **Protect your hearing.** Wear hearing protection during extended periods of operation. Following this rule will reduce the risk of serious personal injury.
 - **Inspect tool cords periodically and, if damaged, have repaired at your nearest authorized service center.** Constantly stay aware of cord location. Following this rule will reduce the risk of electric shock or fire.
 - **Check damaged parts.** Before further use of the tool, a guard or other part that is damaged should be carefully checked to determine that it will operate properly and perform its intended function. Check for alignment of moving parts, binding of moving parts, breakage of parts, mounting, and any other conditions that may affect its operation. A guard or other part that is damaged should be properly repaired or replaced by an authorized service center. Following this rule will reduce the risk of shock, fire, or serious injury.
 - **Do not abuse cord.** Never carry the tool by the cord or yank it to disconnect it from the receptacle. Keep cord away from heat, oil, and sharp edges. Following this rule will reduce the risk of electric shock or fire.
 - **Make sure your extension cord is in good condition.** When using an extension cord, be sure to use one heavy enough to carry the current your product will draw. A wire gage size (A.W.G.) of at least 16 is recommended for an extension cord 100 feet or less in length. A cord exceeding 100 feet is not recommended. If in doubt, use the next heavier gage. The smaller the gage number, the heavier the cord. An undersized cord will cause a drop in line voltage resulting in loss of power and overheating.
 - **Inspect for and remove all nails from lumber before sanding.** Following this rule will reduce the risk of serious personal injury.
 - **Drugs, alcohol, medication.** Do not operate tool while under the influence of drugs, alcohol, or any medication. Following this rule will reduce the risk of electric shock, fire, or serious personal injury.
 - **Save these instructions.** Refer to them frequently and use them to instruct others who may use this tool. If you loan someone this tool, loan them these instructions also.
- ⚠ WARNING:** Some dust created by power sanding, sawing, grinding, drilling, and other construction activities contains chemicals known to cause cancer, birth defects or other reproductive harm. Some examples of these chemicals are:
- lead from lead-based paints,
 - crystalline silica from bricks and cement and other masonry products, and
 - arsenic and chromium from chemically-treated lumber.
- Your risk from these exposures varies, depending on how often you do this type of work. To reduce your exposure to these chemicals: work in a well ventilated area, and work with approved safety equipment, such as those dust masks that are specially designed to filter out microscopic particles.

SYMBOLS

SYMBOL	NAME	DESIGNATION/EXPLANATION
V	Volts	Voltage
A	Amperes	Current
Hz	Hertz	Frequency (cycles per second)
min	Minutes	Time
~	Alternating Current	Type or a characteristic of current
W	Watts	Power
n_0	No Load Speed	Rotational speed, at no load
	Class II Construction	Designates Double Insulated Construction Tools
.../min	Revolutions or Reciprocation Per Minute	Revolutions, strokes, surface speed, orbits etc. per minute
	Safety Alert Symbol	Indicates danger, warning or caution. It means attention!!! Your safety is involved.

The purpose of safety symbols is to attract your attention to possible dangers. The safety symbols, and the explanations with them, deserve your careful attention and understanding. The safety warnings do not by themselves eliminate any danger. The instructions or warnings they give are not substitutes for proper accident prevention measures.

SYMBOL MEANING

	SAFETY ALERT SYMBOL: Indicates danger, warning, or caution. May be used in conjunction with other symbols or pictographs.
	DANGER: Failure to obey a safety warning will result in serious injury to yourself or to others. Always follow the safety precautions to reduce the risk of fire, electric shock, and personal injury.
	WARNING: Failure to obey a safety warning can result in serious injury to yourself or to others. Always follow the safety precautions to reduce the risk of fire, electric shock, and personal injury.
	CAUTION: Failure to obey a safety warning may result in property damage or personal injury to yourself or to others. Always follow the safety precautions to reduce the risk of fire, electric shock, and personal injury.
NOTE:	Advises you of information or instructions vital to the operation or maintenance of the equipment.

SAVE THESE INSTRUCTIONS

PRODUCT SPECIFICATIONS

Size of Sanding Disc	6 inches	Rating	120 volts, 60 Hz, AC only, 4.5 amps.
Size of Polishing Bonnet	6 inches	Spindle Size	1/2 inch 20 TPI
Horsepower	1/2	No Load Speed	1,400/min. & 1650 /min.

OPERATION

⚠ WARNING: Always wear safety goggles or safety glasses with side shields when operating your sander/polisher. Failure to do so could result in dust, shavings, loose particles or foreign objects being thrown into your eyes, causing possible serious injury.

KNOW YOUR SANDER/POLISHER

Your sander/polisher is suitable for sanding with coarse, medium, and fine grit sanding discs. When used with the polishing bonnet supplied, it can also be used as a buffer or polisher.

Before attempting to use any tool, familiarize yourself with all operating features and safety requirements.

⚠ WARNING: The double insulated system is intended to protect the user from shock resulting from a break in the tool's internal wiring. Observe all normal safety precautions related to avoiding electrical shock.

TWO SPEED SWITCH

See Figure 1.

Your sander/polisher is equipped with a two speed switch trigger located in the rear handle. To turn **ON**, depress switch trigger. To turn **OFF**, release switch trigger. For low speed sanding or polishing, depress switch trigger halfway. For high speed sanding or polishing depress switch trigger all the way. **Be sure switch trigger is in OFF position before connecting to power supply source.**

⚠ WARNING: Do not allow familiarity with your tool to make you careless. Remember that a careless fraction of a second is sufficient to inflict severe injury.

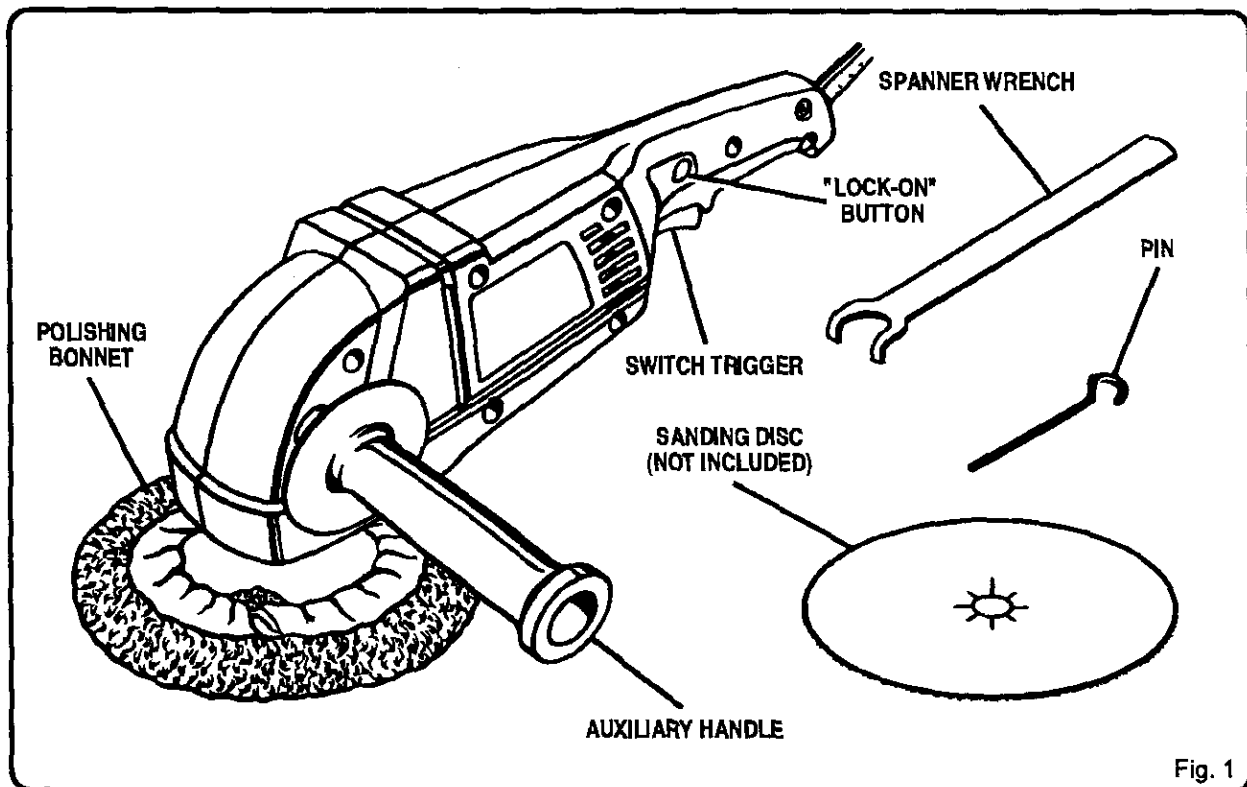

Fig. 1

OPERATION

⚠ WARNING: Your sander/polisher should never be connected to power supply when you are assembling parts, making adjustments, assembling or replacing sanding discs or bonnets, cleaning, or when not in use. Disconnecting sander/polisher will prevent accidental starting that could cause serious personal injury.

LOCK-ON BUTTON

See Figure 2.

Your sander/polisher is equipped with a "lock-on" feature, which is convenient when continuous operation for extended periods of time is required. This feature can be used for both high and low speeds.

To lock on, depress the switch trigger, push in and hold the "lock-on" button located on the side of the handle, then release the switch trigger. Release "lock-on" button and your sander/polisher will continue running. **To release the lock-on feature,** depress switch trigger and release it.

AUXILIARY HANDLE

See Figure 2.

An auxiliary handle is packed with your sander/polisher for ease of operation and to help prevent loss of control. **Any loss of control could result in an accident, causing possible serious personal injury.**

The motor housings are designed so that the auxiliary handle can be installed on either side of the unit.

TO INSTALL:

- Fit bolt through hole in motor housing and thread into hex nut provided internally.
- Tighten bolt and handle securely.

INSTALLING OR REMOVING RUBBER DISC

See Figure 3.

- Unplug your sander/polisher.

⚠ WARNING: Failure to unplug your sander/polisher could result in accidental starting causing possible serious personal injury.

- Position the tool as shown in figure 3 and align the spindle lock hole with the two half-circle notches in motor housing. Lock spindle by inserting the pin provided through spindle lock hole and trapping it in half circle notches. This will prevent spindle from rotating.
- Thread rubber disc, flat face up, onto spindle in a clockwise direction. Turn until rubber disc shoulders on the spindle.
- The unit is now ready for installation of the sanding disc or polishing bonnet.

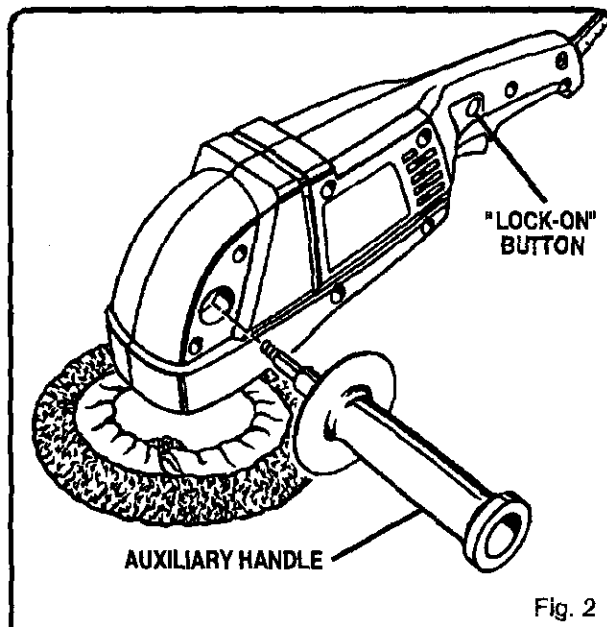

Fig. 2

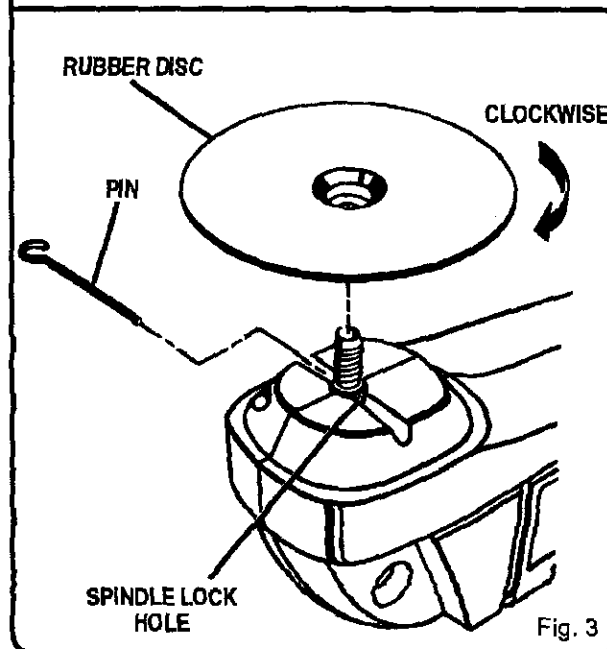

Fig. 3

ELECTRICAL CONNECTION

Your sander/polisher has a precision built electric motor. It should be connected to a power supply that is **120 volts, 60 Hz, AC only (normal household current)**. Do not operate this tool on direct current (DC). A substantial voltage drop will cause a loss of power and the motor will overheat. If your tool does not operate when plugged into an outlet, double-check the power supply.

OPERATION

SANDING DISC SELECTION

Selecting the correct size grit and type sanding disc is an extremely important step in achieving a high quality sanded finish. Aluminum oxide, silicon carbide, and other synthetic abrasives are best for power sanding. Natural abrasives, such as flint and garnet are too soft for economical use in power sanding.

In general, coarse grit will remove the most material and finer grit will produce the best finish in all sanding operations. The condition of the surface to be sanded will determine which grit will do the job. If the surface is rough, start with a coarse grit and sand until the surface is uniform. Medium grit may then be used to remove scratches left by the coarser grit and finer grit used for finishing of the surface.

Always use the proper grit sanding disc, and not extra pressure when sanding. Continue sanding with each grit until surface is uniform.

INSTALLING OPTIONAL SANDING DISC

See Figure 4.

- Unplug your sander/polisher.

⚠ WARNING: Failure to unplug your sander/polisher could result in accidental starting causing possible serious personal injury.

- Position the tool as shown in figure 4 and align the spindle lock hole with the two half-circle notches in motor housing. Lock spindle by inserting the pin provided through spindle lock hole and trapping it in half circle notches. This will prevent spindle from rotating.
- Center the sanding disc over the rubber disc and start spanner nut onto threaded spindle in a clockwise direction.
- Securely tighten spanner nut with the spanner wrench provided.

⚠ WARNING: Remove pin before attempting to operate sander/polisher. Failure to do so could cause pin to be thrown from the tool resulting in possible serious injury.

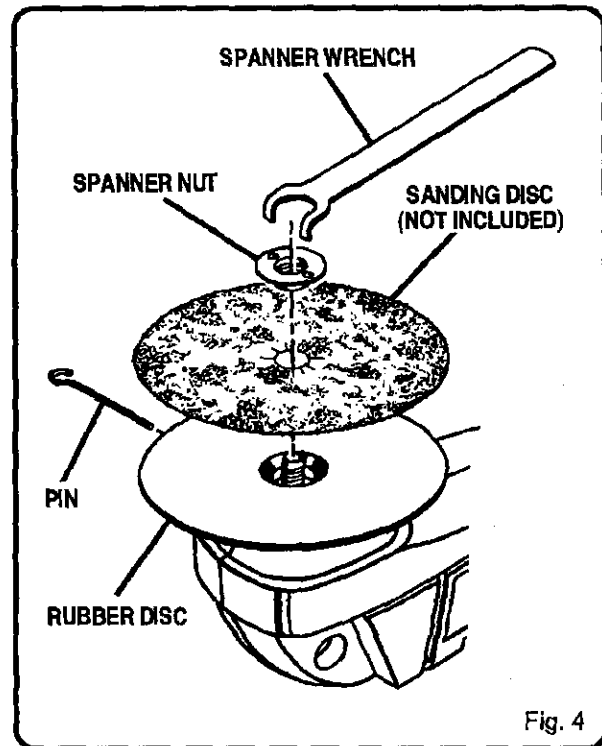

APPLICATIONS

(Use only for the purposes listed below)

- Sanding on wood surfaces.
- Removing rust from and sanding steel surfaces.
- Polishing and buffing.

⚠ WARNING: Before connecting your sander/polisher to power supply source, always check to be sure switch is not in "lock-on" position. Failure to do so could result in accidental starting of your sander/polisher resulting in possible serious injury.

OPERATION

PREPARING FOR OPERATION

For ease of operation, this tool has a front auxiliary handle and rear handle. See Figure 1. This provides for two-hand operation, which is necessary in order to maintain proper control and keep both hands clear of the sanding disc and sanding area. When operating your sander/polisher, always use both hands. Check the auxiliary handle before each use and make sure the handle bolt is tight against the housing.

SANDING

Clamp or otherwise secure the work to prevent it from moving under your sander/polisher. Secure small workpieces in a vise or use clamps to secure them to a workbench.

⚠ WARNING: Unsecured work could be thrown towards the operator causing injury.

Hold the tool in front and away from you, keeping it clear of the workpiece. Start the tool by depressing the switch trigger and letting the motor build to its maximum speed. Gradually lower sander/polisher to the workpiece at a slight 5° to 8° angle. See Figure 5.

DO NOT ATTEMPT TO HOLD THE SANDING DISC FLAT ON THE WORKPIECE.

Always keep the tool in motion moving over the work, allowing it to operate freely without unnecessary pressure. The weight of the unit supplies adequate pressure, so let the sanding disc and sander do the work. Applying additional pressure only slows the motor, rapidly wears sanding discs and greatly reduces sander speed. Excessive pressure will overload the motor causing possible damage from motor overheating and can result in inferior work. Any finish or resin on wood may soften from the frictional heat.

Do not allow sanding on one spot too long. Sanding in one spot too long will cause uneven sanding and gouging of the work.

⚠ WARNING: Keep a firm grip on the tool with both hands at all times. Failure to do so could result in loss of control leading to possible serious injury.

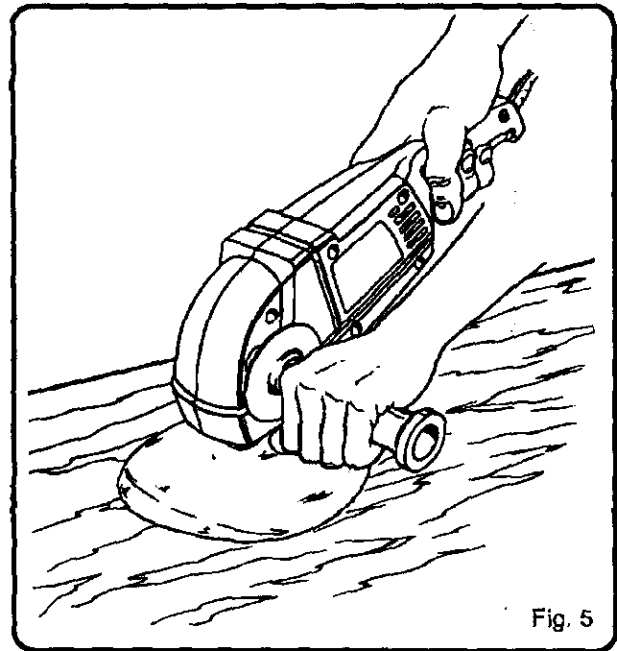

Fig. 5

Upon completion of a sanding operation, lift tool away from work surface before turning off.

⚠ WARNING: Sanding disc must come to a complete stop before setting tool down on workbench. Failure to do so can cause the tool to be thrown from workbench because of sanding disc rotation. This could result in damage to the tool or possible serious injury to the operator.

OPERATION

⚠ WARNING: Do not wear loose clothing or jewelry when operating this tool. They could get caught in moving parts causing serious injury. Keep head away from sander/polisher and sanding or polishing area. Hair could be drawn into sander/polisher causing serious injury.

INSTALLING POLISHING BONNETS

See Figure 6.

■ **Unplug your sander/polisher.**

⚠ WARNING: Failure to unplug your sander/polisher could result in accidental starting causing possible serious personal injury.

- If you have been using this tool as a sander, remove spanner nut and sanding disc.
- Slip polishing bonnet over rubber disc, pull string ends tight, and tie in a bow to secure bonnet.
- Tuck string ends and bow underneath bonnet.

⚠ WARNING: Failure to tuck string ends and bow underneath bonnet could result in string ends coming loose and hitting or grabbing foreign objects.

POLISHING

See Figure 7.

FOR BEST RESULTS, ALWAYS OPERATE AT LOW SPEED WHEN POLISHING.

Hold the tool firmly, allowing it to operate freely without unnecessary pressure. This tool was designed so that the weight of the tool alone will provide adequate pressure for polishing at top efficiency.

BONNETS MUST BE KEPT CLEAN AND FREE FROM GRIT, DIRT, AND OTHER ABRASIVE PARTICLES.

When bonnets become dirty and clogged with polishing film, wash in lukewarm water with a mild detergent. Allow bonnets to dry thoroughly before reuse. Polish with a long sweeping motion, back and forth, advancing along the surface to be polished. Do not hold the tool in one spot or use a circular or spiral pattern. This will cause swirls in the finish. Spread a light coat of polish or wax over a small area. Polish with the tool according to the manufacturer's instructions printed on the label of the polish or wax container.

Note: Some polishes should be buffed while damp where others must be allowed to dry; therefore always check the manufacturer's label.

Tilt the tool so that the polishing bonnet is at a slight angle to the work surface. Always start polishing at the top or highest point and work down. This will prevent light dust or polish film from being thrown upon completed section. It also eliminates pulling the tool's

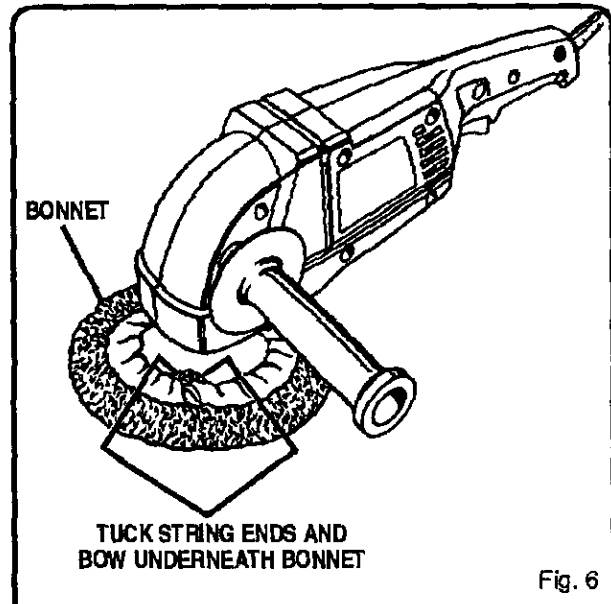
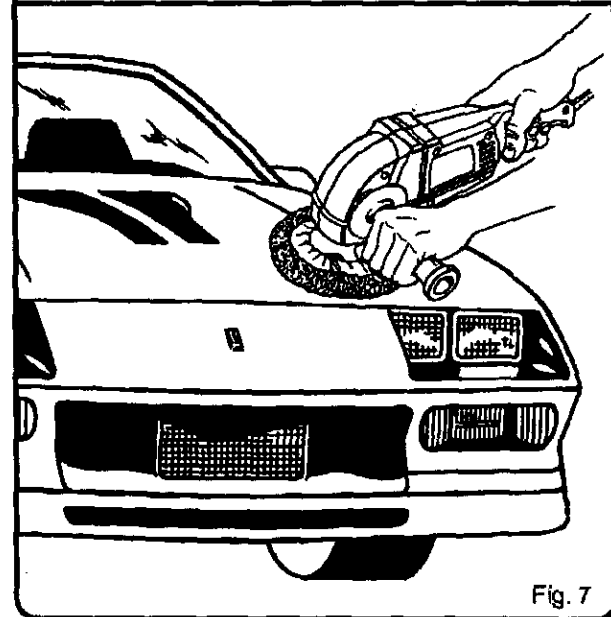

Fig. 6



power cord over sections already polished, particularly on automobiles.

Surfaces that have an old film of wax or polish, or that have not been polished or waxed for an extended period of time, may require a second application. This is especially true on oxidized surfaces. Heavily oxidized surfaces should be cleaned with a commercial paste or liquid cleaner before polishing or waxing.

⚠ WARNING: Check polishing bonnets before each use. Make sure they are clean and free from any loose particles or foreign objects that may be embedded in the bonnet. Failure to do so could cause these particles or objects to be thrown from the tool resulting in possible serious injury.

MAINTENANCE

DOUBLE INSULATION is a safety concept in electric power tools, which eliminates the need for the usual three wire grounded power cord and grounded supply system. Wherever there is electric current in the tool there are two complete sets of insulation to protect the user. All exposed metal parts are isolated from internal metal motor components with protecting insulation.

IMPORTANT — Servicing of a tool with double insulation requires extreme care and knowledge of the system and should be performed only by a qualified service technician. For service we suggest you return the tool to your nearest Sears Store for repair. Always use original factory replacement parts when servicing.

 **WARNING:** When servicing use only identical Craftsman replacement parts. Use of any other parts may create a hazard or cause product damage.

GENERAL

Only the parts shown on parts list, page 13, are intended to be repaired or replaced by the customer. All other parts represent an important part of the double insulation system and should be serviced only by a qualified Sears service technician.

Avoid using solvents when cleaning plastic parts. Most plastics are susceptible to various types of commercial solvents and may be damaged by their use. Use clean cloths to remove dirt, carbon dust, etc.

 **WARNING:** Do not at any time let brake fluids, gasoline, petroleum-based products, penetrating oils, etc. come in contact with plastic parts. They contain chemicals that can damage, weaken, or destroy plastic.

When electric tools are used on fiberglass boats, sports cars, wallboard, spackling compounds, or plaster, it has been found that they are subject to accelerated wear and possible premature failure, as the fiberglass chips and grindings are highly abrasive to bearings, brushes, commutators, etc.

Consequently it is not recommended that this tool be used for extended work on any fiberglass material, wallboard, spackling compounds, or plaster. During any use on these materials, it is extremely important that the tool is cleaned frequently by blowing with an air jet.

 **WARNING:** Always wear safety goggles, or safety glasses with side shields during power tool operation or when blowing dust. If operation is dusty, also wear a dust mask.

EXTENSION CORDS

The use of any extension cord will cause some loss of power. To keep the loss to a minimum and to prevent tool overheating, use an extension cord that is heavy enough to carry the current the tool will draw.

A wire gauge size (A.W.G.) of at least 16 is recommended for an extension cord 100 feet or less in length. When working outdoors, use an extension cord that is suitable for outdoor use. The cord's jacket will be marked **WA**.

 **CAUTION:** Keep extension cords away from the sanding area and position the cord so that it will not get caught on lumber, tools, etc., during sanding or polishing operation.

 **WARNING:** Check extension cords before each use. If damaged replace immediately. Never use tool with a damaged cord since touching the damaged area could cause electrical shock resulting in serious injury.

LUBRICATION

All of the bearings in this tool are lubricated with a sufficient amount of high grade lubricant for the life of the unit under normal operating conditions. Therefore, no further lubrication is required.

ACCESSORIES

THE FOLLOWING RECOMMENDED ACCESSORIES ARE CURRENTLY AVAILABLE AT SEARS RETAIL STORES

Polishing Bonnet

Assorted Sanding Discs

150 Grit — Fine

100 Grit — Medium

60 Grit — Coarse

40 Grit — Very Coarse

 **WARNING:** The use of attachments or accessories not listed above might be hazardous.

CRAFTSMAN SANDER/POLISHER – MODEL NUMBER

315.115070

SEE NOTE "A", Page 13

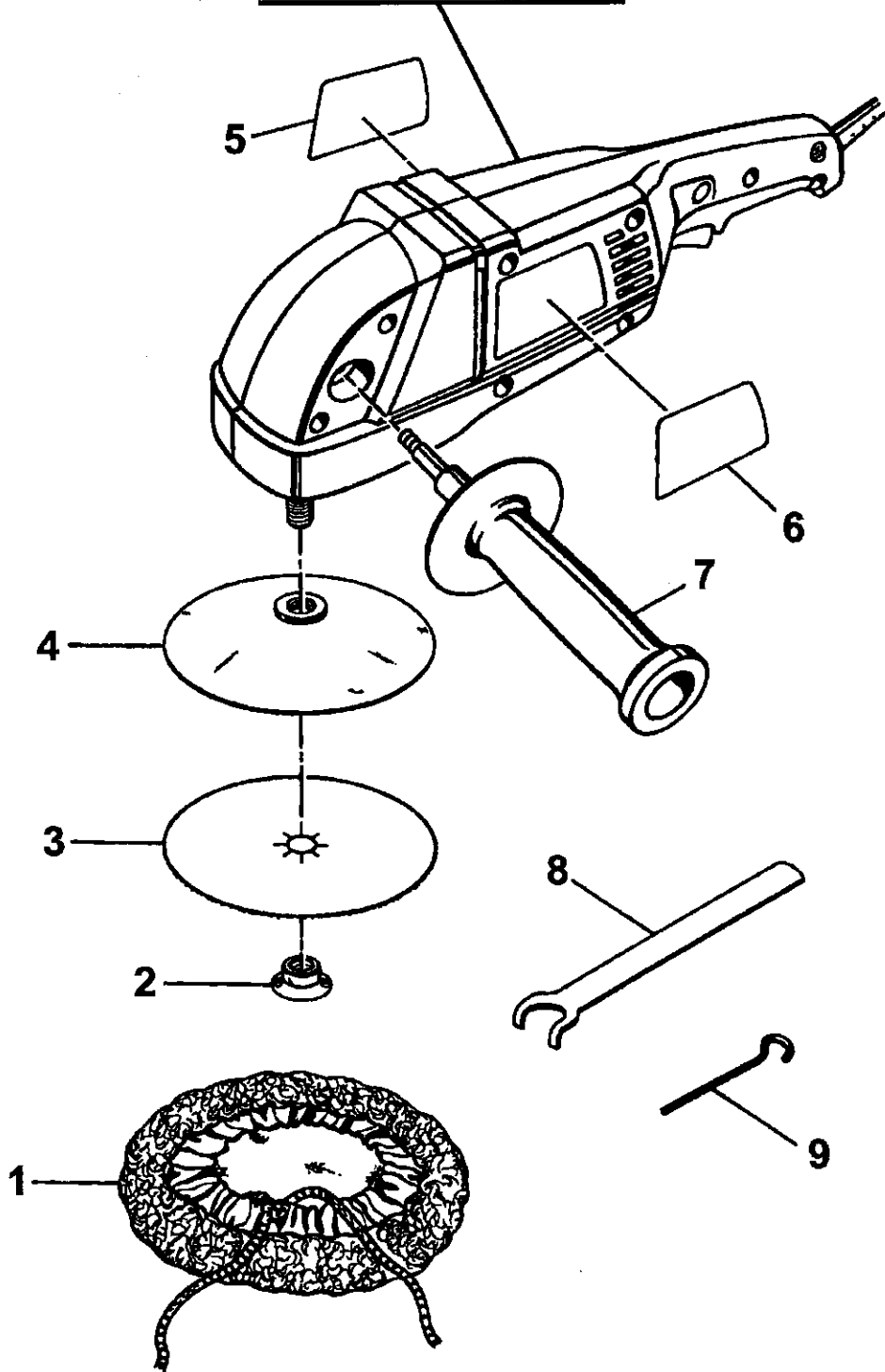

CRAFTSMAN SANDER/POLISHER – MODEL NUMBER 315.115070

The model number will be found on a plate attached to the motor housing. Always mention the model number in all correspondence regarding your CRAFTSMAN SANDER/POLISHER or when ordering repair parts.

SEE BACK PAGE FOR PARTS ORDERING INSTRUCTIONS**PARTS LIST**

Key No.	Part Number	Description	Quan.
1	974892-001	Polishing Bonnet.....	1
2	612186-003	Spanner Nut.....	1
3	***	Sanding Disc	
4	622322-001	Rubber Disc	1
5	983001-001	Data Plate	1
6	976491-001	Logo Plate	1
7	972895-005	Auxiliary Handle	1
8	621984-000	Spanner Wrench	1
9	621230-000	Pin.....	1
	972000-990	Operator's Manual	

NOTE: "A" — The assembly shown represents an important part of the Double Insulated System. To avoid the possibility of alteration or damage to the System, service should be performed by your nearest Sears Repair Center. Contact your nearest Sears Catalog Order or Retail Store for service center information.

***** Sanding discs in assorted grits for sanding both wood and metal may be obtained from your nearest Sears Retail Store.**

Get fixed, at your home or ours!

Your Home

For repair – **in your home** – of all major brand appliances, lawn and garden equipment, or heating and cooling systems, **no matter who made it, no matter who sold it!**

For the replacement parts, accessories and owner's manuals that you need to do-it-yourself.

For Sears professional installation of home appliances and items like garage door openers and water heaters.

1-800-4-MY-HOME® (1-800-469-4663)

Call anytime, day or night (U.S.A. and Canada)

www.sears.com www.sears.ca

Our Home

For repair of carry-in items like vacuums, lawn equipment, and electronics, call or go on-line for the location of your nearest **Sears Parts & Repair Center.**

1-800-488-1222

Call anytime, day or night (U.S.A. only)

www.sears.com

To purchase a protection agreement on a product serviced by Sears:

1-800-827-6655 (U.S.A.)

1-800-361-6665 (Canada)

Para pedir servicio de reparación a domicilio, y para ordenar piezas:

1-888-SU-HOGARSM

(1-888-784-6427)

Au Canada pour service en français:

1-800-LE-FOYER^{MC}

(1-800-533-6937)

www.sears.ca

SEARS