

Owner's Manual

CRAFTSMAN®

AUTO-SCROLL SAW

Variable Speed - Adjustable

Double Insulated

Model No.
315.172321

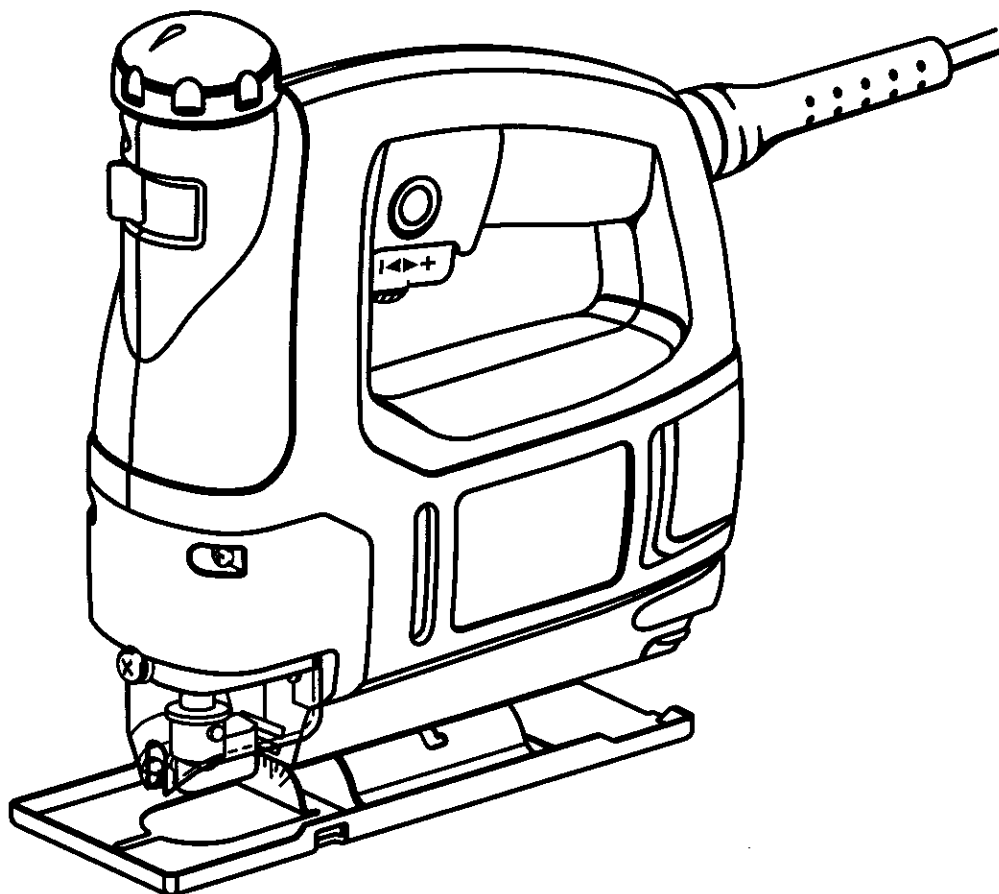

Save this manual for
future reference

⚠ CAUTION: Read and follow
all Safety Rules and Operating
Instructions before first use of
this product.

Customer Help Line: 1-800-932-3188

Sears, Roebuck and Co., Hoffman Estates, IL 60179 USA
Visit the Craftsman web page: www.sears.com/craftsman

- Safety
- Features
- Assembly
- Operation
- Maintenance
- Parts List



TABLE OF CONTENTS

■ Table Of Contents	2
■ General Safety Rules	2-3
■ Specific Safety Rules/Symbols	4
■ Features	5-6
■ Assembly	7
■ Operation	8-13
■ Maintenance	14
■ Accessories	15
■ Exploded View And Repair Parts List	16-17
■ Parts Ordering / Service	18

GENERAL SAFETY RULES

WARNING: Read and understand all instructions. Failure to follow all instructions listed below, may result in electric shock, fire, and/or serious personal injury.

SAVE THESE INSTRUCTIONS

Work Area

- **Keep your work area clean and well lit.** Cluttered benches and dark areas invite accidents.
- **Do not operate power tools in explosive atmospheres, such as in the presence of flammable liquids, gases, or dust.** Power tools create sparks which may ignite the dust or fumes.
- **Keep bystanders, children, and visitors away while operating a power tool.** Distractions can cause you to lose control.

Electrical Safety

- **Double insulated tools are equipped with a polarized plug (one blade is wider than the other). This plug will fit in a polarized outlet only one way. If the plug does not fit fully in the outlet, reverse the plug. If it still does not fit, contact a qualified electrician to install a polarized outlet. Do not change the plug in any way.** Double insulation eliminates the need for the three wire grounded power cord and grounded power supply system.
- **Avoid body contact with grounded surfaces, such as pipes, radiators, ranges, and refrigerators.** There is an increased risk of electric shock if your body is grounded.
- **Don't expose power tools to rain or wet conditions.** Water entering a power tool will increase the risk of electric shock.
- **Do not abuse the cord. Never use the cord to carry the tools or pull the plug from an outlet.**

Keep cord away from heat, oil, sharp edges, or moving parts. Replace damaged cords immediately. Damaged cords increase the risk of electric shock.

- **When operating a power tool outside, use an outdoor extension cord marked "W-A" or "W."** These cords are rated for outdoor use and reduce the risk of electric shock.

Personal Safety

- **Stay alert, watch what you are doing, and use common sense when operating a power tool. Do not use tool while tired or under the influence of drugs, alcohol, or medication.** A moment of inattention while operating power tools may result in serious personal injury.
- **Dress properly. Do not wear loose clothing or jewelry. Contain long hair. Keep your hair, clothing, and gloves away from moving parts.** Loose clothes, jewelry, or long hair can be caught in moving parts.
- **Avoid accidental starting. Be sure switch is off before plugging in.** Carrying tools with your finger on the switch or plugging in tools that have the switch on invites accidents.
- **Remove adjusting keys or wrenches before turning the tool on.** A wrench or a key that is left attached to a rotating part of the tool may result in personal injury.
- **Do not overreach. Keep proper footing and balance at all times.** Proper footing and balance enables better control of the tool in unexpected situations.
- **Use safety equipment. Always wear eye protection.** Dust mask, nonskid safety shoes, hard hat, or hearing protection must be used for appropriate conditions.

GENERAL SAFETY RULES

Tool Use and Care

- **Use clamps or another practical way to secure and support the workpiece to a stable platform.** Holding the work by hand or against your body is unstable and may lead to loss of control.
- **Do not force tool. Use the correct tool for your application.** The correct tool will do the job better and safer at the rate for which it is designed.
- **Do not use tool if switch does not turn it on or off.** Any tool that cannot be controlled with the switch is dangerous and must be repaired.
- **Disconnect the plug from the power source before making any adjustments, changing accessories, or storing the tool.** Such preventive safety measures reduce the risk of starting the tool accidentally.
- **Store idle tools out of the reach of children and other untrained persons.** Tools are dangerous in the hands of untrained users.
- **Maintain tools with care.** Keep cutting tools sharp and clean. Properly maintained tools with sharp cutting edges are less likely to bind and are easier to control.

- **Check for misalignment or binding of moving parts, breakage of parts, and any other condition that may affect the tool's operation.** If damaged, have the tool serviced before using. Many accidents are caused by poorly maintained tools.
- **Use only accessories that are recommended by the manufacturer for your model.** Accessories that may be suitable for one tool may become hazardous when used on another tool.

Service

- **Tool service must be performed only by qualified repair personnel.** Service or maintenance performed by unqualified personnel could result in a risk of injury.
- **When servicing a tool, use only identical replacement parts. Follow instructions in the Maintenance section of this manual.** Use of unauthorized parts or failure to follow Maintenance Instructions may create a risk of electric shock or injury.



SPECIFIC SAFETY RULES AND/OR SYMBOLS

Hold tool by insulated gripping surfaces when performing an operation where the cutting tool may contact hidden wiring or its cord. Contact with a "live" wire will make exposed metal parts of the tool "live" and shock the operator.

Additional Rules for Safe Operation

- **Know your power tool. Read operator's manual carefully. Learn its applications and limitations, as well as the specific potential hazards related to this tool.** Following this rule will reduce the risk of electric shock, fire, or serious injury.
 - **Always wear safety glasses. Everyday eye-glasses have only impact-resistant lenses; they are NOT safety glasses.** Following this rule will reduce the risk of serious personal injury.
 - **Protect your lungs. Wear a face or dust mask if the operation is dusty.** Following this rule will reduce the risk of serious personal injury.
 - **Protect your hearing. Wear hearing protection during extended periods of operation.** Following this rule will reduce the risk of serious personal injury.
 - **Inspect tool cords periodically and, if damaged, have repaired at your nearest Factory Service Center or other Authorized Service Organization. Constantly stay aware of cord location.** Following this rule will reduce the risk of electric shock or fire.
 - **Check damaged parts. Before further use of the tool, a guard or other part that is damaged should be carefully checked to determine that it will operate properly and perform its intended function. Check for alignment of moving parts, binding of moving parts, breakage of parts, mounting, and any other conditions that may affect its operation. A guard or other part that is damaged should be properly repaired or replaced by an authorized service center.** Following this rule will reduce the risk of electric shock, fire, or serious injury.
 - **Don't abuse cord. Never carry the tool by the cord or yank it to disconnect it from the receptacle. Keep cord away from heat, oil, and sharp edges.** Following this rule will reduce the risk of electric shock or fire.
 - **Make sure your extension cord is in good condition. When using an extension cord, be sure to use one heavy enough to carry the current your product will draw. A wire gage size (A.W.G.) of at least 16 is recommended for an extension cord 100 feet or less in length. A cord exceeding 100 feet is not recommended. If in doubt, use the next heavier gage. The smaller the gage number, the heavier the cord.** An undersized cord will cause a drop in line voltage resulting in loss of power and overheating.
 - **Inspect for and remove all nails from lumber before cutting.** Following this rule will reduce the risk of serious personal injury.
 - **Drugs, alcohol, medication. Do not operate tool while under the influence of drugs, alcohol, or any medication.** Following this rule will reduce the risk of electric shock, fire, or serious personal injury.
 - **Save these instructions. Refer to them frequently and use them to instruct others who may use this tool. If you loan someone this tool, loan them these instructions also.**
- ⚠ WARNING:** Some dust created by power sanding, sawing, grinding, drilling, and other construction activities contains chemicals known to cause cancer, birth defects or other reproductive harm. Some examples of these chemicals are:
- lead from lead-based paints,
 - crystalline silica from bricks and cement and other masonry products, and
 - arsenic and chromium from chemically-treated lumber.
- Your risk from these exposures varies, depending on how often you do this type of work. To reduce your exposure to these chemicals: work in a well ventilated area, and work with approved safety equipment, such as those dust masks that are specially designed to filter out microscopic particles.

SYMBOLS

SYMBOL	NAME	DESIGNATION/EXPLANATION
V	Volts	Voltage
A	Amperes	Current
Hz	Hertz	Frequency (cycles per second)
W	Watt	Power
min	Minutes	Time
~	Alternating Current	Type or a characteristic of current
n_0	No Load Speed	Rotational speed, at no load
	Class II Construction	Designates Double Insulated Construction tools
.../min	Revolutions or Reciprocation Per Minute	Revolutions, strokes, surface speed, orbits etc. per minute
	Safety Alert Symbol	Indicates danger, warning or caution. It means attention!!! Your safety is involved.

FEATURES

DEFINITIONS

- A) **DANGER:** Failure to obey a safety warning will result in serious injury to yourself or to others. Always follow the safety precautions to reduce the risk of fire, electric shock and personal injury.
- B) **WARNING:** Failure to obey a safety warning can result in serious injury to yourself or to others. Always follow the safety precautions to reduce the risk of fire, electric shock and personal injury.
- C) **CAUTION:** Failure to obey a safety warning may result in property damage or personal injury to yourself or to others. Always follow the safety precautions to reduce the risk of fire, electric shock and personal injury.
- D) **NOTE:** Advises you of information or instructions vital to the operation or maintenance of the equipment.

FEATURES

KNOW YOUR SAW

See Figure 1.

Before attempting to use your saw, familiarize yourself with all operating features and safety requirements.

Your saw has many features for making cutting operations more pleasant and enjoyable. Safety, performance, and dependability have been given top priority in the design of this saw making it easy to maintain and operate.

CAUTION: Carefully read through this entire owner's manual before using your new saw. Pay close attention to the Rules For Safe Operation, Warnings, and Cautions. If you use your saw properly and only for what it is intended, you will enjoy years of safe, reliable service.

CHIP SHIELD

See Figure 2.

A clear plastic chip shield has been provided on the front of your saw for protection against flying dust and chips. It is designed to fit the front opening of your saw. **For your protection, do not use saw without chip shield properly in place.**

VACUUM ATTACHMENT

A vacuum attachment is packed with your saw. This attachment is convenient when operating your saw for an extended period of time.

APPLICATIONS

(Use only for the purposes listed below)

- Cutting wood surfaces.
- Cutting thin sheet metal.
- Cutting plastics and laminates.

ELECTRICAL CONNECTION

Your saw has a precision-built electric motor. It should be connected to a **power supply that is 120 volts, 60 Hz, AC only (normal household current)**. Do not operate this tool on direct current (DC). A substantial voltage drop will cause a loss of power and overheating. If your tool does not operate when plugged into an outlet, double-check the power supply.

PRODUCT SPECIFICATIONS

Length of Stroke	3/4 in.
Strokes per Minute	0-3000 SPM
Rating	120 Volts, 60 Hz, AC
Input	3.5 Amperes
Switch	Variable Speed - Adjustable
Net Weight	4 lbs.

WARNING: Do not allow familiarity with tools to make you careless. Remember that a careless fraction of a second is sufficient to inflict severe injury.

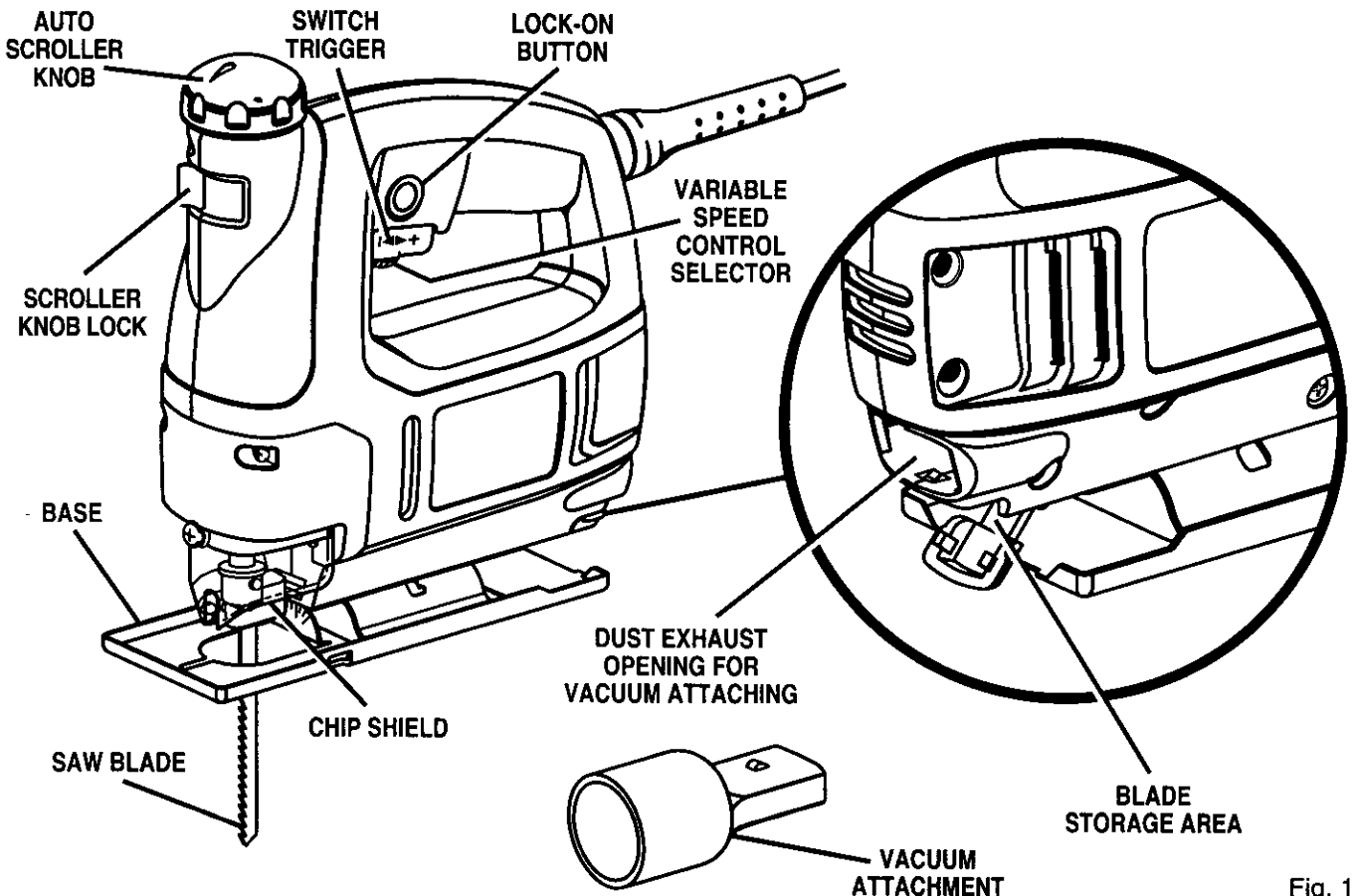

Fig. 1

ASSEMBLY

Your saw has been shipped completely assembled except for the blade. Inspect it carefully to make sure no breakage or damage has occurred during shipping. If any parts are damaged or missing, contact your nearest Sears retail store to obtain replacement parts before attempting to operate saw. A blade, vacuum attachment, and this owner's manual are also included.

⚠ WARNING: If any parts are missing, do not operate this tool until the missing parts are replaced. Failure to do so could result in possible serious personal injury.

TWO BLADE SLOTS

Your saw has been designed with two blade slots. For general cutting, making straight cuts, angle cutting, plunge cutting, or splinter-free cutting, or when using a flush cutting blade, install blade in the front slot. For scroll cutting, install blade in the back slot.

⚠ WARNING: To avoid possible serious injury, always wear safety goggles or safety glasses with side shields. Keep hands and fingers from between the motor housing and blade clamp and do not reach underneath work while blade is cutting.

TO INSTALL BLADE

See Figure 2.

- With saw connected to power supply, depress and release switch trigger until blade clamp is all the way down.
- **Unplug your saw.**

⚠ WARNING: Failure to unplug your saw could result in accidental starting causing possible serious injury.

- Before installing blade, determine the type of cutting operation you will be doing so you will know which slot to insert saw blade.
- Using a flatblade screwdriver, loosen the blade screw in the blade clamp.
- Insert saw blade as far as possible into slot in blade clamp.
- Tighten blade screw securely against blade.

Note: The holes in the saw blades were not designed for alignment with the screw hole on the blade clamp.

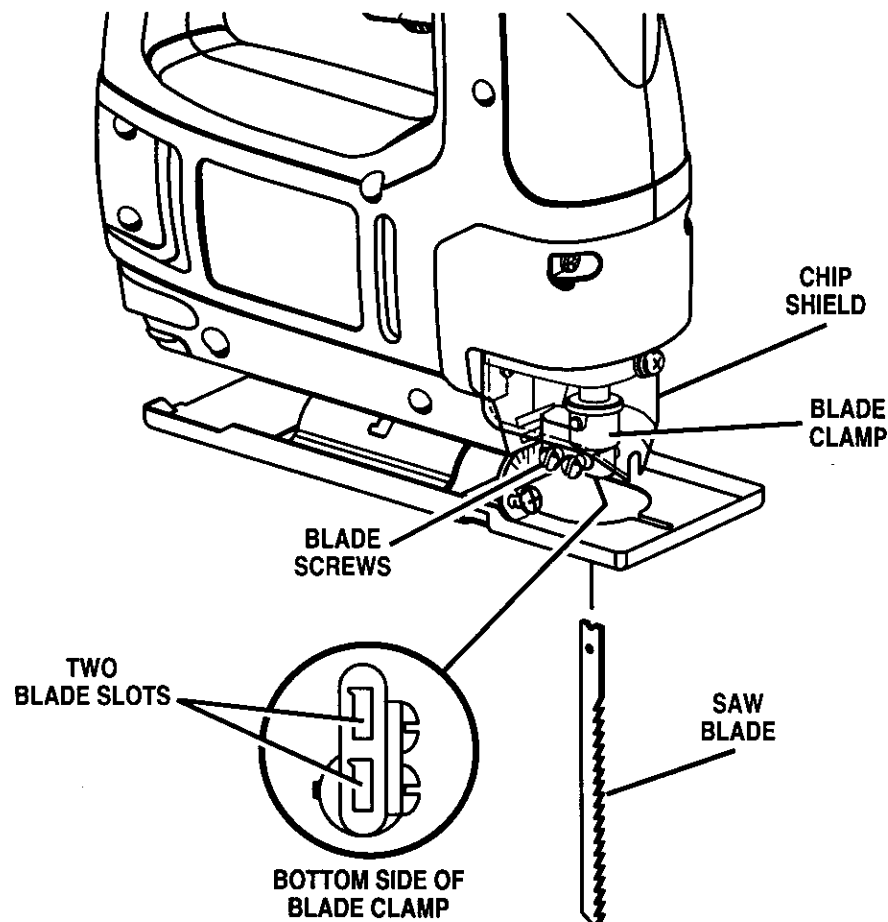

Fig. 2

OPERATION

⚠ WARNING: Do not attempt to operate this tool until you have read thoroughly and understand completely all instructions, safety rules, etc., contained in this manual. Failure to comply can result in accidents involving fire, electric shock, or serious personal injury. Save owner's manual, and review frequently for continuing safe operation and for instructing others who may use this tool.

SWITCH

See Figure 3.

To turn your saw **ON**, depress the switch trigger. Release switch trigger to turn your saw **OFF**.

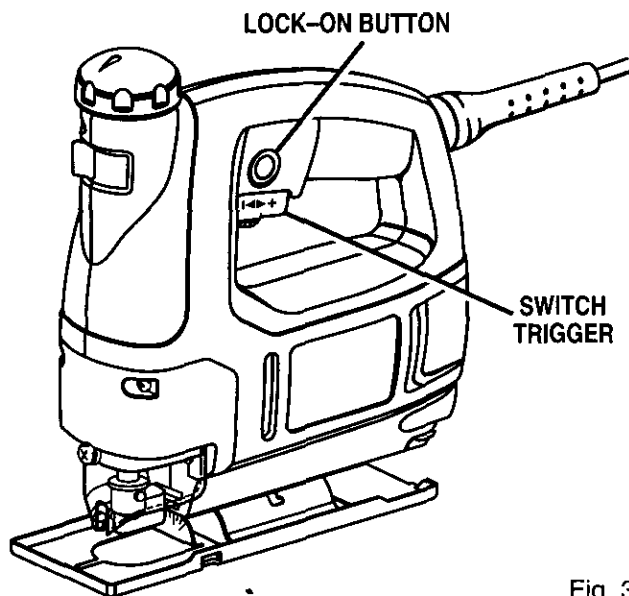

Fig. 3

LOCK-ON BUTTON

See Figure 3.

Your saw is equipped with a **lock-on** feature, which is convenient when continuous cutting is required for extended periods of time. **To lock-on**, depress the switch trigger; push in and hold the lock-on button, located on the side of the handle; then release the switch trigger. Release lock-on button and your saw will continue running.

To release the lock, depress the switch trigger and release.

If you have the lock-on feature engaged during use and your saw becomes disconnected from the power supply, disengage the lock-on feature immediately.

⚠ WARNING: Before connecting your saw to the power supply source, always check to be sure it is not in lock-on position (depress and release switch trigger). **Failure to do so could result in accidental starting of your saw, resulting in possible serious injury. Also, do not lock the trigger on jobs where your saw may need to be stopped suddenly.**

VARIABLE SPEED

See Figure 4.

Your saw has a variable speed control selector designed to allow operator control and adjustment of speed and power limits. The speed and power of your saw can be increased or decreased by rotating the variable speed control selector in the direction of the arrows shown in Figure 4.

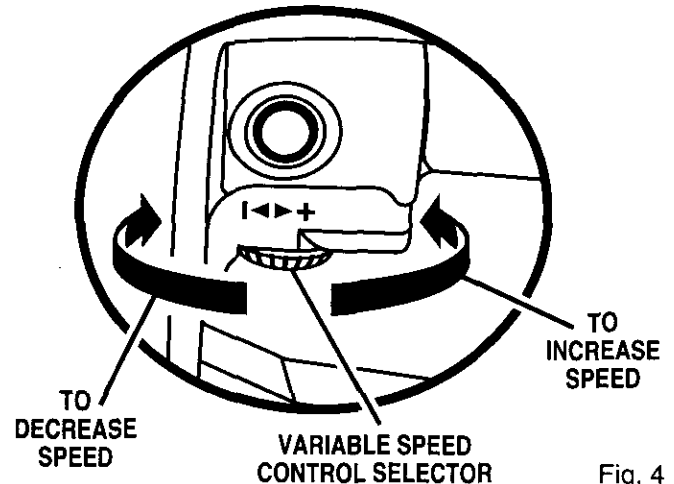

Fig. 4

Note: Hold your saw in normal operating position and turn the variable speed control selector counterclockwise to increase speed and power. Turn clockwise to decrease speed and power.

If you desire to lock the switch on at a given speed, depress the switch trigger, push in, and hold the lock-on button, and release the switch trigger. Next, adjust the variable speed control selector until the desired speed is reached.

Note: If the variable speed control selector is fully turned in the clockwise direction (zero setting), your saw may not run.

Note: If you desire not to use the variable speed control selector, turn it in the full counterclockwise direction. This will allow the speed of your saw to be controlled by the amount of switch trigger depression.

Avoid running your saw at low speeds for extended periods of time. Running at low speeds under constant usage may cause your saw to become overheated. If this occurs, cool your saw by running it without a load and at full speed.

The following guidelines may be used in determining correct speed for various applications:

Low speed is ideal when minimum speed and power is required. For example, starting cuts.

Medium speed is suitable for cutting hard metals, plastics, and laminates.

High speed produces best results when maximum power is required. For example, cutting wood. Soft metals such as aluminum, brass, and copper also require high speeds.

OPERATION

BLADE STORAGE

See Figure 5.

A convenient feature on your saw is a blade storage area. As shown in Figure 5, the blade storage area is located on the back of your saw. This is a convenient place for storing extra blades or storing blades when not in use.

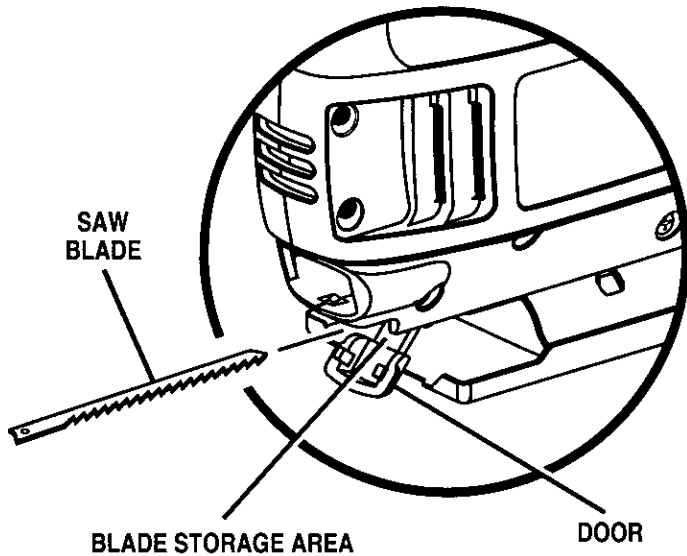

Fig. 5

To open:

- Push the door down with your thumb or finger.
- Place blades in blade storage area.

To close:

- Push the door up with your thumb or finger.

⚠ WARNING: Do not insert saw blade into air vents. Blade could come in contact with electrical live internal parts and cause electrical shock, resulting in serious injury.

⚠ WARNING: Your saw should never be connected to power supply when you are assembling parts, making adjustments, installing or removing blades, or when not in use. Disconnecting your saw will prevent accidental starting that could cause serious injury.

⚠ WARNING: To avoid serious personal injury, do not use saw without chip shield properly in place.

As previously mentioned, there are two blade slots on your saw. Install blade in the front slot for general cutting, making straight cuts, angle cutting, plunge cutting, splinter-free cutting, and when using a flush cutting blade. Install blade in the back slot when scroll cutting.

GENERAL CUTTING

See Figure 6.

Rest the front of the saw base on the workpiece and align cutting edge of the blade with the line on your workpiece. Make sure the power cord is out of your way and not in the line of cut. Start your saw and move it forward on the work surface. Apply downward pressure to keep the saw steady and only enough forward pressure to keep the blade cutting.

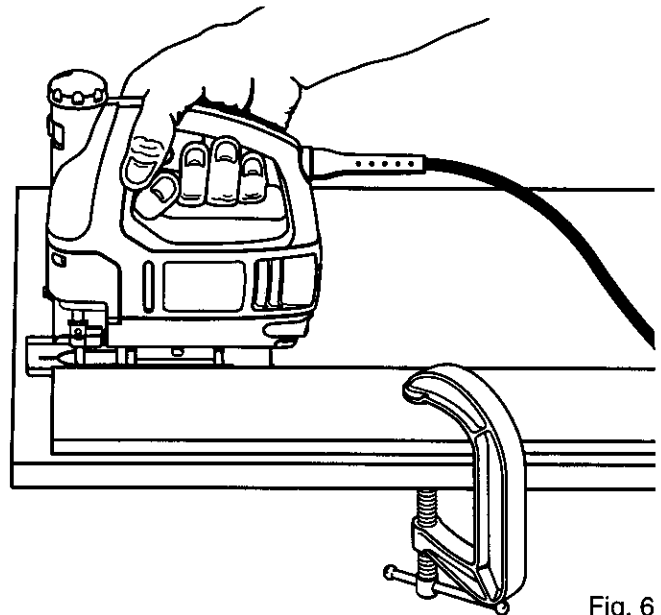

Fig. 6

DO NOT FORCE YOUR SAW

Forcing your saw may overheat the motor and break saw blades. Broken blades can be reused by loosening the blade screws until the portion left in the blade clamp drops out, then putting the remainder of the blade back into the blade clamp and retightening the blade screws. It may be necessary to flatten the tooth set in the area to be inserted into the blade clamp when using broken blades.

STRAIGHT CUT

See Figure 6.

A straight cut can be made by clamping a piece of wood or straightedge to the workpiece and guiding the edge of your saw against it. Make the cut from one direction only: don't cut halfway and complete the cut from the opposite end.

OPERATION

⚠ WARNING: To avoid possible serious injury, keep hands and fingers from between the gear housing and saw blade clamp.

SCROLLER KNOB LOCK

See Figure 7.

Your saw is equipped with a thumb operated lock for locking the knob in (4) positions, 90° apart. Lock and unlock the scroller mechanism of your saw by rotating the lock, located on the front of your saw, in the direction of the arrows as shown in Figure 7. Locking the knob as shown in Figure 7 permits cuts to be made close to walls and corners. For scroll cutting, the lock must be in the unlocked position for free rotation of the saw bar.

SCROLL CUTTING

See Figures 8 and 9.

Your auto-scroll saw is designed to permit 360° rotation of the saw blade so that intricate designs may be cut with minimum effort with the blade installed in the back slot. Your saw may be operated either by rotating the auto scroller knob manually with your free hand, or by guiding the direction of the cut with applied pressure on the handle as shown in figures 8 and 9.

⚠ WARNING: Excessive side pressure to the blade could result in broken blades or damage to the material being cut.

METAL CUTTING

Many kinds of metals can be cut with your saw. Be careful not to twist or bend the blades. **Do not force.** If the blade chatters or vibrates excessively, use a finer-tooth blade or higher speed. If blade heats excessively, use lower speed. If blade teeth become filled or clogged when cutting soft metals, such as aluminum, use a coarser-tooth blade or lower speed. We recommend use of oil when cutting metals to keep blades cool, increase cutting action, and prolong blade life. Clamp the work firmly and saw close to the clamping point to eliminate any vibration of the work being cut.

When cutting conduit, pipe or angle iron, clamp work in a vise if possible and saw close to the vise. To cut thin sheet materials, "sandwich" the material between hardboard or plywood and clamp the layers to eliminate vibration and material tearing. By doing this, the material will be cut smoothly. Lay out your pattern or line of cut on top of the "sandwich".

Important – When cutting metal, keep exposed portion of saw bar clean and free of metal chips by wiping frequently with an oily cloth. Use extreme caution in disposing of oily cloth after completion of job to prevent potential fire hazard.

⚠ CAUTION: To avoid possible injury, never wipe saw bar while the saw is running.

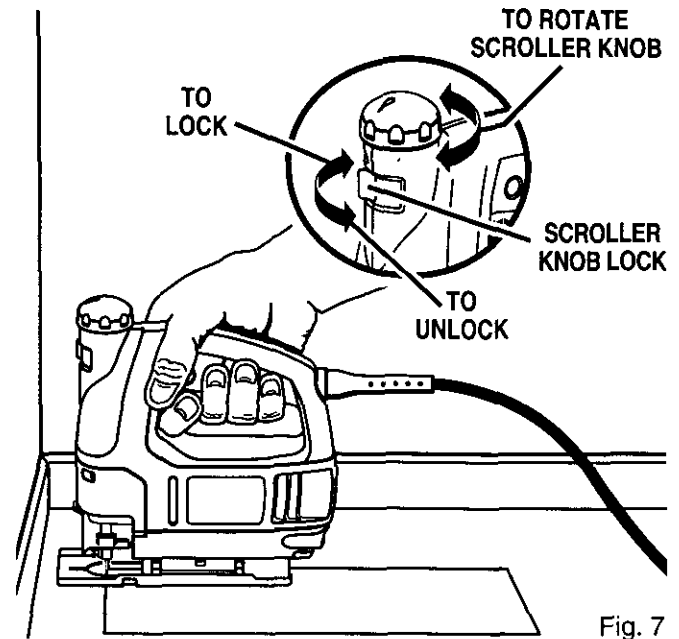

Fig. 7

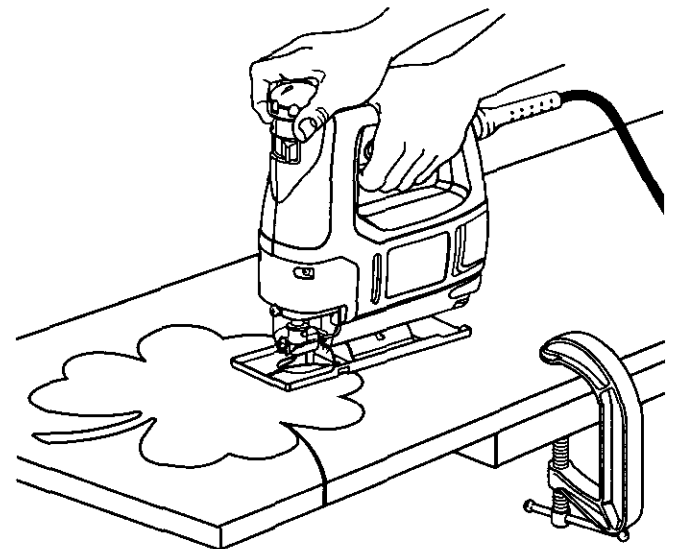

Fig. 8

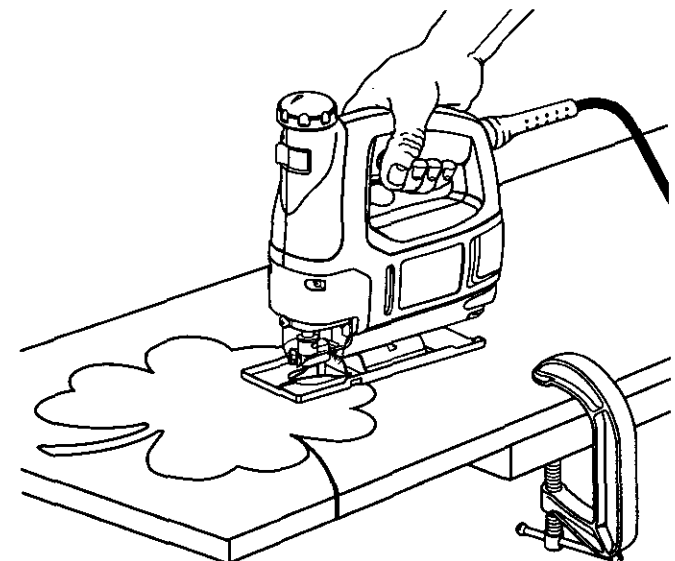

Fig. 9

OPERATION

ANGLE CUTTING (Bevel Cutting)

See Figures 10 and 11.

Bevel cutting angles may be adjusted from 0° to 45° right or left. Angles for cuts from 0° to 45° in 15° increments are marked on a scale on the front of the saw base. A protractor is recommended when accurate cuts are required.

- Using a screwdriver, loosen the base pivot screw until the base can move freely in slot in base.
- Adjust base until mark on scale (desired angle) aligns with the parting line located on the front of the motor housing.
- Once the desired angle is reached, tighten the base pivot screw securely. See Figure 10.

Note: The large opening in the base must be used when making bevel cuts, scroll cuts, plunge cuts, and when cutting metal.

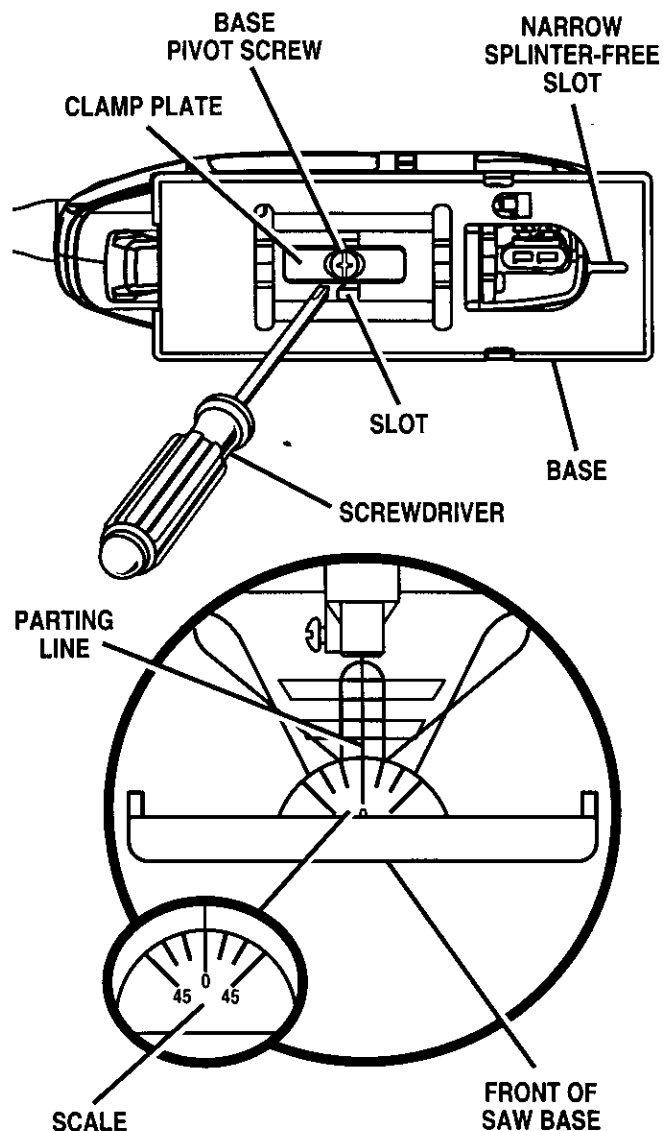

Fig. 10

Note: When bevel cutting with the saw tilted 45° to the right, you will first need to rotate the blade clamp 180° and reverse the blade as shown in Figure 11. Make sure the scroll knob is locked in place and the cutting edge of the blade is facing forward.

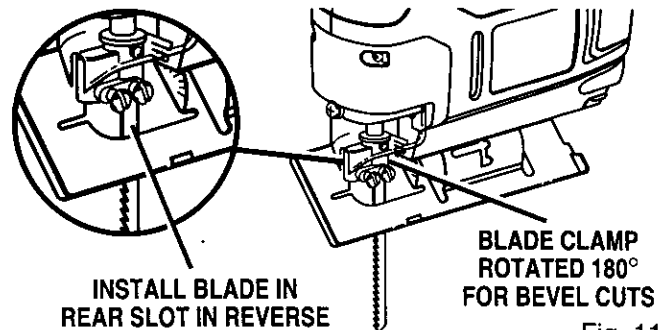

Fig. 11

PLUNGE CUTTING

See Figure 12.

WARNING: To avoid loss of control, broken blades, or damage to the material being cut, always use extreme caution when making plunge cuts. We do not recommend plunge cutting on materials other than wood.

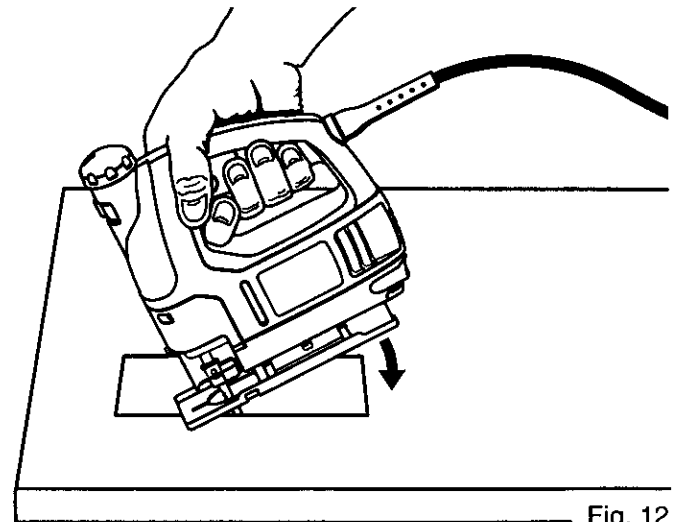

Fig. 12

TO MAKE A PLUNGE CUT

- Mark the line of cut clearly on the workpiece.
- Set the cutting angle at 0°.
- Tilt your saw forward so that it rests on the front edge of the base, and the blade will not come in contact with the workpiece when the saw is turned on.
- Make sure the blade is inside the area to be cut.
- Using high speed, start your saw and slowly lower the blade into the workpiece until the blade cuts through the wood. See Figure 12.
- Continue lowering the blade into the workpiece until the base rests flat on the work surface, then move the saw forward to complete the opening.
- Use only the 7-teeth-per-inch blade for this type of cut.

OPERATION

SPLINTER-FREE CUTTING

See Figure 13.

The base of your saw has a narrow slot to permit splinter-free cutting. It is especially useful when cutting plywood. This feature should only be used when making straight cuts or circle cuts. It is not for bevel cutting or plunge cutting.

Note: The variable speed setting also helps reduce splintering when cutting plywood.

HOW TO POSITION BASE IN THE SPLINTER-FREE CUTTING POSITION:

- Unplug your saw.

⚠ WARNING: Failure to unplug your saw could result in accidental starting causing possible serious injury.

- Using a screwdriver, loosen base pivot screw and slide base to the rear. See Figure 13.
- Always set the cutting angle at 0° for splinter-free cutting. To set cutting angle at 0°, align the 0° mark on the scale with the parting line on the motor housing.
- Tighten base pivot screw securely.

VACUUM ATTACHMENT

See Figure 14.

For dustless operation, a vacuum attachment is packed with your saw. This attachment easily attaches to your saw if you decide to connect your saw to a vacuum.

- Unplug your saw.

⚠ WARNING: Failure to unplug your sander could result in accidental starting causing possible serious personal injury.

TO ATTACH:

- Insert vacuum attachment into dust exhaust opening. See Figure 14.
- Push in on adapter until raised notch on top and bottom of attachment snap into groove in dust exhaust opening.
- Snugly attach attachment to vacuum hose.
- Connect vacuum hose to cleaner.

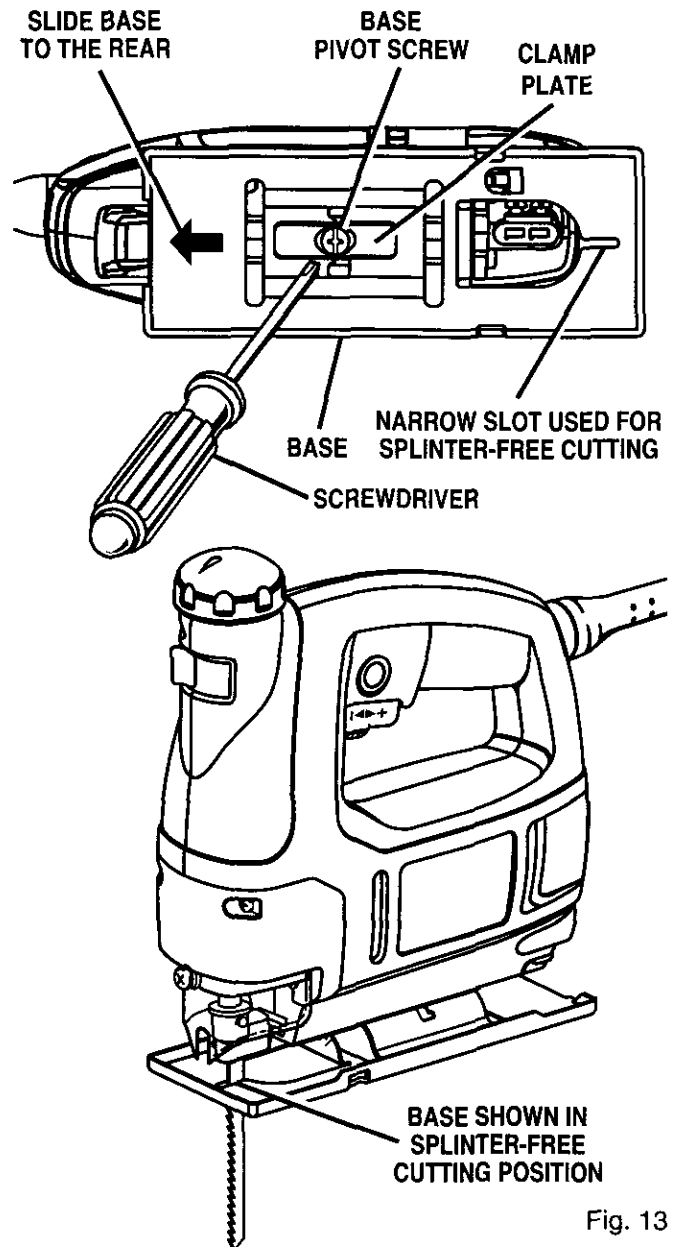

Fig. 13

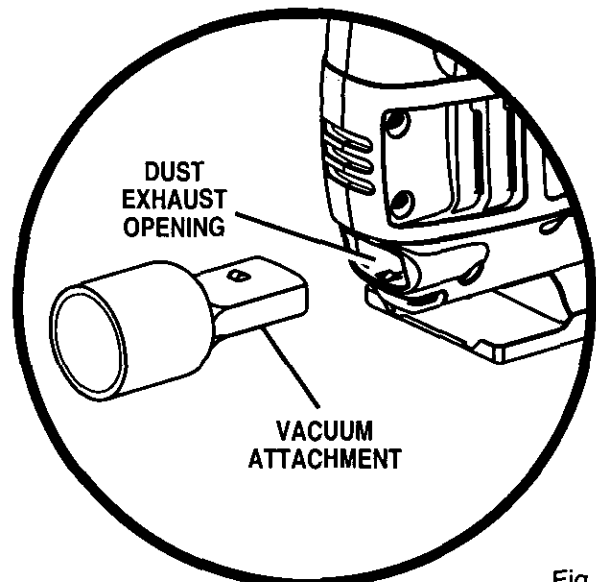

Fig. 14

OPERATION

TO INSTALL OPTIONAL FLUSH CUTTING BLADES

See Figures 15 and 16.

Flush cutting blades should be used when making close or flush cuts to the walls.

■ Unplug your saw.

⚠ WARNING: Failure to unplug your saw could result in accidental starting causing possible serious injury.

- Using a screwdriver, loosen base pivot screw and rotate base 180° as shown in Figure 15.
- Slide base all the way to the rear of saw.
- Set the cutting angle at 0°. To set, adjust base until 0° mark on scale aligns with the parting line located on the front of the motor housing.
- Tighten base pivot screw securely.

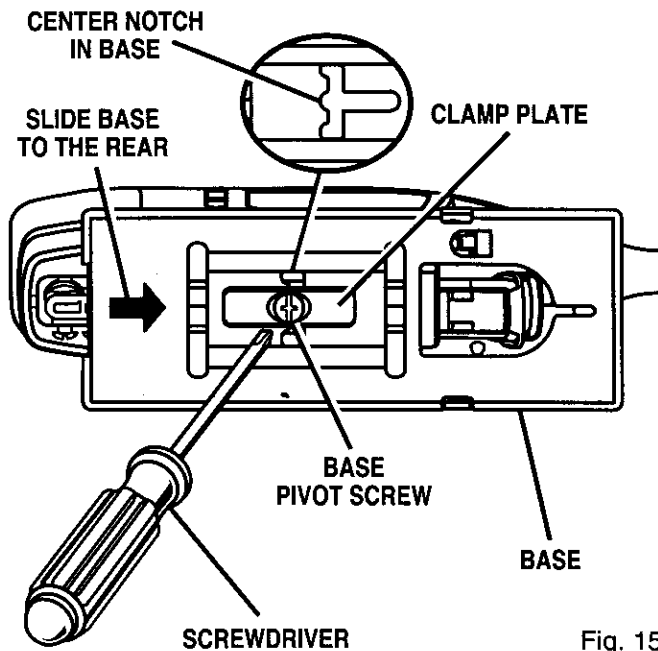

Fig. 15

TO INSTALL:

See Figure 16.

- In the blade clamp, loosen the blade screw in front blade slot and insert flush cutting blade as far as possible into slot.
- Tighten blade screw securely.

Note: The holes in the saw blades were not designed for alignment with the screw hole in the blade clamp.

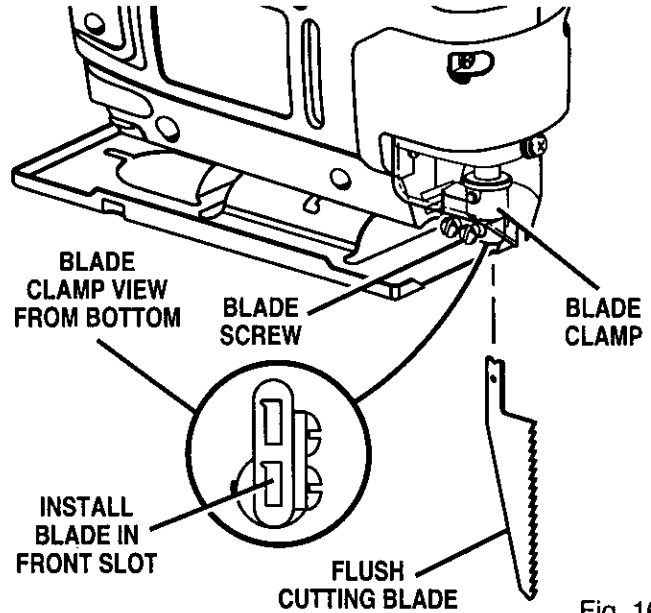

Fig. 16

OPTIONAL EDGE GUIDE

See Figure 17.

An optional edge guide, Item Number 9 27959, is available for use with your saw. It can be used for making crosscuts and rip cuts.

TO INSTALL:

■ Unplug your saw.

⚠ WARNING: Failure to unplug your saw could result in accidental starting causing possible serious injury.

- Insert arm through the two slots in the base of your saw as shown in Figure 17.
- Adjust edge guide to the desired width and lock in place with the edge guide screw.

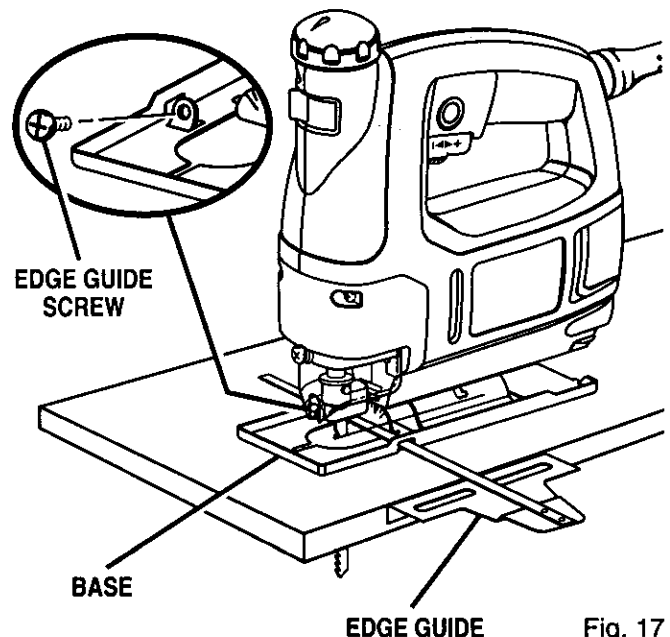



Fig. 17

MAINTENANCE

GENERAL

All parts represent an important part of the double insulation system and should be serviced only by a qualified Sears service technician.

Avoid using solvents when cleaning plastic parts. Most plastics are susceptible to damage from various types of commercial solvents and may be damaged by their use. Use clean cloths to remove dirt, carbon dust, etc.

 **WARNING:** Do not at any time let brake fluids, gasoline, petroleum-based products, penetrating oils, etc. come in contact with plastic parts. They contain chemicals that can damage, weaken or destroy plastic.

It has been found that electric tools are subject to accelerated wear and possible premature failure when they are used on fiberglass boats, sports cars, wallboard, spackling compounds, or plaster. The chips and grindings from these materials are highly abrasive to electric tool parts, such as bearings, brushes, commutators, etc. Consequently, it is not recommended that this tool be used for extended work on any fiberglass material, wallboard, spackling compounds, or plaster. During any use on these materials, it is extremely important that the tool is cleaned frequently by blowing with an air jet.

LUBRICATION

All of the bearings in this tool are lubricated with a sufficient amount of high-grade lubricant for the life of the unit under normal-operating conditions. Therefore, no further lubrication is required.

 **WARNING:** Always wear safety goggles or safety glasses with side shields during power tool operation or when blowing dust. If operation is dusty, also wear a dust mask.

DOUBLE INSULATION

Double insulation is a concept in safety in electric power tools, which eliminates the need for the usual three-wire grounded power cord. All exposed metal parts are isolated from the internal metal motor components with protecting insulation. Double insulated tools do not need to be grounded.

IMPORTANT

Servicing of a tool with double insulation requires extreme care and knowledge of the system and should be performed only by a qualified service technician. For service, we suggest you return the tool to your nearest Sears store for repair. Always use original factory replacement parts when servicing.

EXTENSION CORDS

The use of any extension cord will cause some loss of power. To keep the loss to a minimum and to prevent tool overheating, use an extension cord that is heavy enough to carry the current the tool will draw.

A wire gage size (A.W.G.) of at least **16** is recommended for an extension cord 100 feet or less in length. When working outdoors, use an extension cord that is suitable for outdoor use. The cord's jacket will be marked **WA**.

 **CAUTION:** Keep extension cords away from the cutting area and position the cord so that it will not get caught on lumber, tools, etc., during cutting operation.

 **WARNING:** Check extension cords before each use. If damaged replace immediately. Never use tool with a damaged cord since touching the damaged area could cause electrical shock resulting in serious injury.

Extension cords suitable for use with your saw are available at your nearest Sears Retail Store.

ACCESSORIES

The following recommended accessories are currently available at Sears retail stores.

- Bi-Metal Blades
- Blade Assortment Sets
- Fine Scrolling Blades
- General Purpose Blades
- Metal Cutting Blades
- Wood Cutting Blades
- Edge Guide

⚠ WARNING: The use of attachments or accessories not listed might be hazardous.

⚠ WARNING:



The operation of any saw can result in foreign objects being thrown into your eyes, which can result in severe eye damage. Before beginning power tool operation, always wear safety goggles or safety glasses with side shields and a full face shield when needed. We recommend Wide Vision Safety Mask for use over eyeglasses or standard safety glasses with side shields, available at Sears retail stores.

WARRANTY

FULL ONE YEAR WARRANTY ON CRAFTSMAN SCROLL SAW

If this **CRAFTSMAN** Scroll Saw fails to give complete satisfaction within one year from the date of purchase, **RETURN IT TO THE NEAREST SEARS STORE IN THE UNITED STATES**, and Sears will repair it, free of charge.

If this **CRAFTSMAN** Scroll Saw is used for commercial or rental purposes, this warranty applies for only 90 days from the date of purchase.

This warranty gives you specific legal rights, and you may also have other rights which vary from state to state.

Sears, Roebuck and Co., Dept. 817WA, Hoffman Estates, IL 60179

SAVE THESE INSTRUCTIONS

Get it fixed, at your home or ours!

For repair of major brand appliances **in your own home...**
no matter who made it, no matter who sold it!

1-800-4-MY-HOMESM Anytime, day or night
(1-800-469-4663)

www.sears.com

To bring in products such as vacuums, lawn equipment and electronics
for repair, call for the location of your nearest **Sears Parts & Repair Center.**

1-800-488-1222 Anytime, day or night

www.sears.com

For the replacement parts, accessories and owner's manuals
that you need to do-it-yourself, call **Sears PartsDirectSM!**

1-800-366-PART 6 a.m. – 11 p.m. CST,
(1-800-366-7278) 7 days a week

www.sears.com/partsdirect

To purchase or inquire about a Sears Service Agreement:

1-800-827-6655

7 a.m. – 5 p.m. CST, Mon. – Sat.

Para pedir servicio de reparación a domicilio,
y para ordenar piezas con entrega a domicilio

1-888-SU-HOGARSM
(1-888-784-6427)

Au Canada pour service en français.

1-877-LE-FOYERSM
(1-877-533-6937)

