

Operator's Manual

CRAFTSMAN

DUSTLESS PLATE JOINER

Double Insulated

Model No.
315.175011

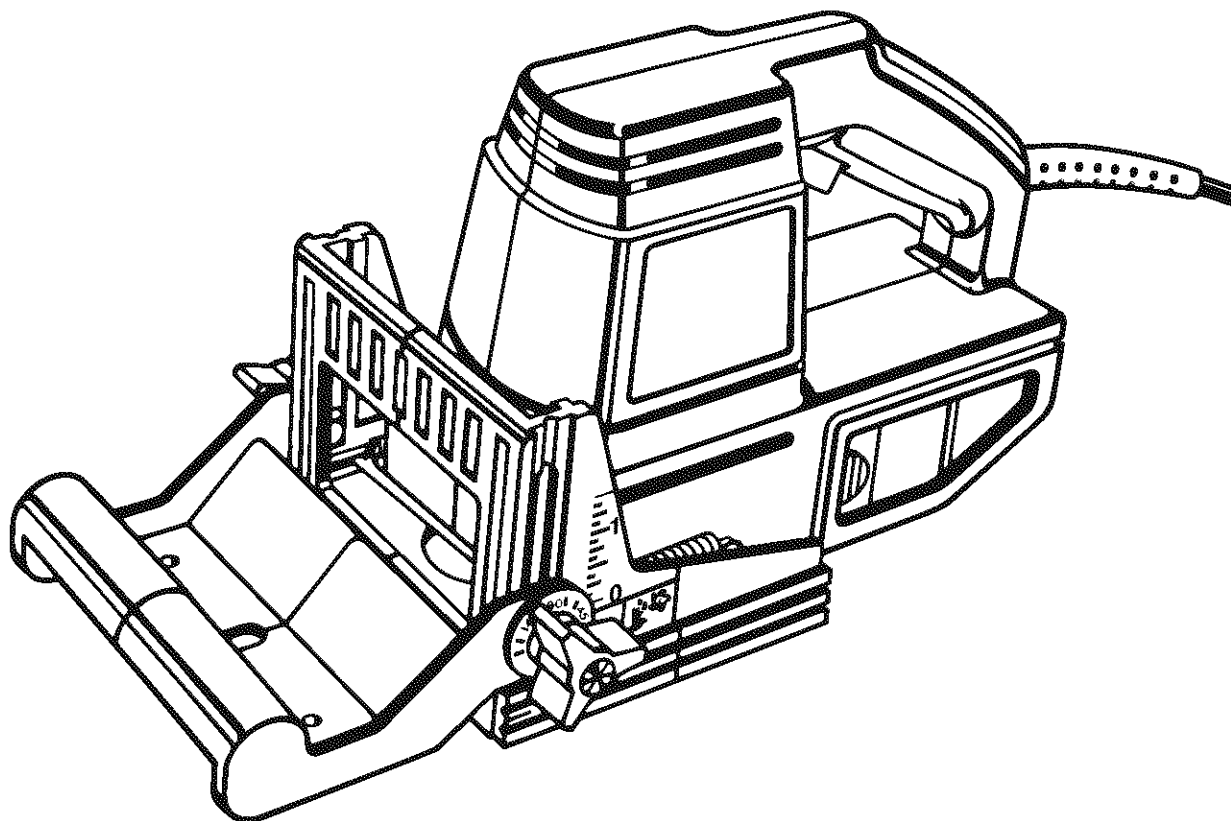

Save this manual for
future reference

▲ WARNING: To reduce the risk of injury, the user must read and understand the operator's manual before using this product.

- Safety
- Features
- Operation
- Maintenance
- Parts List

Customer Help Line: 1-800-932-3188

Sears Roebuck and Co., 3333 Beverly Rd., Hoffman Estates, IL 60179 USA
Visit the Craftsman web page: www.sears.com/craftsman

972000-979
6-03



TABLE OF CONTENTS

■ Warranty and Introduction	2
■ General Safety Rules	3-4
■ Specific Safety Rules	4
■ Symbols	5
■ Unpacking	6
■ Features	7-8
■ Adjustments	9-10
■ Operation	11-17
■ Maintenance	17-20
■ Troubleshooting	21
■ Exploded View and Repair Parts List	22-23
■ Parts Ordering / Service	24

WARRANTY

FULL ONE YEAR WARRANTY ON CRAFTSMAN PLATE JOINER

If this **CRAFTSMAN** Plate Joiner fails to give complete satisfaction within one year from the date of purchase, **RETURN IT TO THE NEAREST SEARS STORE IN THE UNITED STATES**, and Sears will repair it, free of charge.

If this **CRAFTSMAN** Plate Joiner is used for commercial or rental purposes, this warranty applies for only 90 days from the date of purchase.

This warranty gives you specific legal rights, and you may also have other rights which vary from state to state.

Sears, Roebuck and Co., Dept. 817WA, Hoffman Estates, IL 60179

INTRODUCTION

Your Plate Joiner has many features for making cutting operations more pleasant and enjoyable. Safety, performance and dependability have been given top priority in the design of this Plate Joiner, making it easy to maintain and operate.

Spline joinery is one of the strongest methods of joinery used in woodworking. When glue is properly applied to a spline and to the joint area of the wood pieces being connected, a large surface area receives the adhesion properties of the glue. This forms a very strong joint.

Traditional spline joinery requires cutting slots with a router or table saw. Small, thin strips of wood must then be cut to fit inside the slots and act as splines.

Newer methods of spline joinery use a plate or biscuit joiner to cut precise mating oval slots in adjoining boards. Your new Plate Joiner is a fast, simple, and accurate plunge cutting tool that can be used for this purpose. It can be used to cut slots in hardwood, softwood, plywood, particle board, and other pressed woods.



CAUTION: Carefully read through this entire operator's manual before using your new Plate Joiner. Pay close attention to the Rules For Safe Operation, Warnings and Cautions. If you use your Plate Joiner properly and only for what it is intended, you will enjoy years of safe, reliable service.

Football shaped wafers, called biscuits, are then placed inside the slots with glue and used to help line up adjoining surfaces. When a water based glue is used, the biscuits swell in the joint, making an extremely strong and firm bond. White glue, yellow glue, carpenters glue, hide glue, and aliphatic resin glue are examples of water based glues.

This bonding technique has traditionally been limited to making edge-to-edge joints. However, with the use of your new Plate Joiner, biscuits can now be easily used to connect butt, miter, and T-joints. Biscuit joining can be as strong as mortise and tenon, tongue and groove, standard spline, and doweled joints. In most cases the material around the biscuit will break before the biscuit itself will break. A greater surface area is exposed to glue in a biscuit joint, making the seams stronger.

GENERAL SAFETY RULES

⚠ WARNING: Read and understand all instructions. Failure to follow all instructions listed below may result in electric shock, fire and/or serious personal injury.

SAVE THESE INSTRUCTIONS

Work Area

- **Keep your work area clean and well lit.** Cluttered benches and dark areas invite accidents.
- **Do not operate power tools in explosive atmospheres, such as in the presence of flammable liquids, gases, or dust.** Power tools may create sparks which may ignite the dust or fumes.
- **Keep bystanders, children, and visitors away while operating a power tool.** Distractions can cause you to lose control.

Electrical Safety

- **Double insulated tools are equipped with a polarized plug (one blade is wider than the other). This plug will fit in a polarized outlet only one way. If the plug does not fit fully in the outlet, reverse the plug. If it still does not fit, contact a qualified electrician to install a polarized outlet. Do not change the plug in any way.** Double insulation eliminates the need for the three-wire grounded power cord and grounded power supply system.
- **Avoid body contact with grounded surfaces, such as pipes, radiators, ranges, and refrigerators.** There is an increased risk of electric shock if your body is grounded.
- **Don't expose power tools to rain or wet conditions.** Water entering a power tool will increase the risk of electric shock.
- **Do not abuse the cord. Never use the cord to carry the tools or pull the plug from an outlet. Keep cord away from heat, oil, sharp edges, or moving parts. Replace damaged cords immediately.** Damaged cords increase the risk of electric shock.
- **When operating a power tool outside, use an outdoor extension cord marked "W-A" or "W".** These cords are rated for outdoor use and reduce the risk of electric shock.

Personal Safety

- **Stay alert, watch what you are doing and use common sense when operating a power tool. Do not use tool while tired or under the influence of drugs, alcohol, or medication.** A moment of inattention while operating power tools may result in serious personal injury.

- **Dress properly. Do not wear loose clothing or jewelry. Contain long hair. Keep your hair, clothing, and gloves away from moving parts.** Loose clothes, jewelry, or long hair can be caught in moving parts.
- **Avoid accidental starting. Be sure switch is off before plugging in.** Carrying tools with your finger on the switch or plugging in tools that have the switch on, invites accidents.
- **Remove adjusting keys or wrenches before turning the tool on.** A wrench or a key that is left attached to a rotating part of the tool may result in personal injury.
- **Do not overreach. Keep proper footing and balance at all times.** Proper footing and balance enables better control of the tool in unexpected situations.
- **Use safety equipment. Always wear eye protection. Dust mask, nonskid safety shoes, hard hat, or hearing protection must be used for appropriate conditions.**

Tool Use and Care

- **Use clamps or other practical way to secure and support the workpiece to a stable platform.** Holding the work by hand or against your body is unstable and may lead to loss of control.
- **Do not force tool. Use the correct tool for your application.** The correct tool will do the job better and safer at the rate for which it is designed.
- **Do not use tool if switch does not turn it on or off.** Any tool that cannot be controlled with the switch is dangerous and must be repaired.
- **Disconnect the plug from power source before making any adjustments, changing accessories, or storing the tool.** Such preventive safety measures reduce the risk of starting the tool accidentally.
- **Store idle tools out of the reach of children and other untrained persons.** Tools are dangerous in the hands of untrained users.
- **Maintain tools with care. Keep cutting tools sharp and clean.** Properly maintained tools with sharp cutting edges are less likely to bind and are easier to control.
- **Check for misalignment or binding of moving parts, breakage of parts, and any other condition that may affect the tool's operation. If damaged, have the tool serviced before using.** Many accidents are caused by poorly maintained tools.
- **Use only accessories that are recommended by the manufacturer for your model.** Accessories that may be suitable for one tool, may become hazardous when used on another tool.

GENERAL SAFETY RULES

Service

- **Tool service must be performed only by qualified repair personnel.** Service or maintenance performed by unqualified personnel could result in a risk of injury.
- **When servicing a tool, use only identical replacement parts.** Follow instructions in the Maintenance section of this manual. Use of unauthorized parts or failure to follow Maintenance Instructions may create a risk of electric shock or injury.

SPECIFIC SAFETY RULES

- **Hold tool by insulated gripping surfaces when performing an operation where the tool may contact hidden wiring or its cord.** Contact with a “live” wire will make exposed metal parts of the tool “live” and shock the operator.

Additional Rules For Safe Operation

- **Know your power tool.** Read operator’s manual carefully. Learn its applications and limitations, as well as the specific potential hazards related to this tool. Following this rule will reduce the risk of electric shock, fire, or serious injury.
- **Always wear safety glasses.** Everyday eye-glasses have only impact-resistant lenses; they are NOT safety glasses. Following this rule will reduce the risk of serious personal injury.
- **Protect your lungs.** Wear a face or dust mask if the operation is dusty. Following this rule will reduce the risk of serious personal injury.
- **Protect your hearing.** Wear hearing protection during extended periods of operation. Following this rule will reduce the risk of serious personal injury.
- **Inspect tool cords periodically and, if damaged, have repaired at your nearest authorized service center.** Constantly stay aware of cord location. Following this rule will reduce the risk of electric shock or fire.
- **Check damaged parts.** Before further use of the tool, a guard or other part that is damaged should be carefully checked to determine that it will operate properly and perform its intended function. Check for alignment of moving parts, binding of moving parts, breakage of parts, mounting, and any other conditions that may affect its operation. A guard or other part that is damaged should be properly repaired or replaced by an authorized service center. Following this rule will reduce the risk of shock, fire, or serious injury.
- **Do not abuse cord.** Never carry the tool by the cord or yank it to disconnect it from the receptacle. Keep cord away from heat, oil, and sharp edges. Following this rule will reduce the risk of electric shock or fire.
- **Keep a firm grip on detail biscuit joiner with both hands at all times.**
- **Make sure your extension cord is in good condition.** When using an extension cord, be sure to use one heavy enough to carry the current your product will draw. A wire gage size (A.W.G.) of at least 16 is recommended for an extension cord 100 feet or less in length. A cord exceeding 100 feet is not recommended. If in doubt, use the next heavier gage. The smaller the gage number, the heavier the cord. An undersized cord will cause a drop in line voltage resulting in loss of power and overheating.
- **Inspect for and remove all nails from lumber before sanding.** Following this rule will reduce the risk of serious personal injury.
- **Drugs, alcohol, medication.** Do not operate tool while under the influence of drugs, alcohol, or any medication. Following this rule will reduce the risk of electric shock, fire, or serious personal injury.
- **Save these instructions.** Refer to them frequently and use them to instruct others who may use this tool. If you loan someone this tool, loan them these instructions also.







WARNING: Some dust created by power sanding, sawing, grinding, drilling, and other construction activities contains chemicals known to cause cancer, birth defects or other reproductive harm. Some examples of these chemicals are:

- lead from lead-based paints,
- crystalline silica from bricks and cement and other masonry products, and
- arsenic and chromium from chemically-treated lumber.

Your risk from these exposures varies, depending on how often you do this type of work. To reduce your exposure to these chemicals: work in a well ventilated area, and work with approved safety equipment, such as those dust masks that are specially designed to filter out microscopic particles.

SYMBOLS

Important: Some of the following symbols may be used on your tool. Please study them and learn their meaning. Proper interpretation of these symbols will allow you to operate the tool better and safer.

SYMBOL	NAME	DESIGNATION/EXPLANATION
V	Volts	Voltage
A	Amperes	Current
Hz	Hertz	Frequency (cycles per second)
W	Watt	Power
min	Minutes	Time
~	Alternating Current	Type of current
n_0	No Load Speed	Rotational speed, at no load
	Class II Construction	Double-insulated construction
/min	Per Minute	Revolutions, strokes, surface speed, orbits etc. per minute
	Safety Alert	Precautions that involve your safety
	Eye Protection	Always wear safety goggles or safety glasses with side shields and a full face shield when operating this product.
	Wet Conditions Alert	Do not expose to rain or use in damp locations.

The purpose of safety symbols is to attract your attention to possible dangers. The safety symbols, and the explanations with them, deserve your careful attention and understanding. The safety warnings do not by themselves eliminate any danger. The instructions or warnings they give are not substitutes for proper accident prevention measures.

SYMBOL MEANING



DANGER: Indicates an imminently hazardous situation, which, if not avoided, will result in death or serious injury.



WARNING: Indicates a potentially hazardous situation, which, if not avoided, could result in death or serious injury.



CAUTION: Indicates a potentially hazardous situation, which, if not avoided, may result in minor or moderate injury. It may also be used to alert against unsafe practices that may cause property damage.

Important: Advises you of important information or instructions vital to the operation or maintenance of the equipment.

Note: Advises you of additional information concerning the operation or maintenance of the equipment.

UNPACKING

Your Plate Joiner has been shipped completely assembled and ready for use. Inspect it carefully to make sure no breakage or damage has occurred during shipping. If any parts are damaged or missing, contact your nearest Sears Retail Store to obtain replacement parts before attempting to operate Biscuit Joiner.

DOUBLE INSULATION

Double insulation is a concept in safety, in electric power tools, which eliminates the need for the usual three-wire grounded power cord. All exposed metal parts are isolated from internal metal motor components with protecting insulation. Double insulated tools do not need to be grounded.

 **WARNING:** If any parts are missing, do not operate this tool until the missing parts are replaced. Failure to do so could result in possible serious personal injury.

IMPORTANT

Servicing of a tool with double insulation requires extreme care and knowledge of the system and should be performed only by a qualified service technician. For service we suggest you return the tool to your nearest Sears Store for repair. Always use original factory replacement parts when servicing.

 **Look for this symbol to point out important safety precautions. It means attention!!! Your safety is involved.**

 **WARNING:**

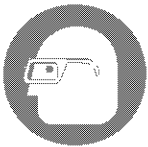

The operation of any Plate Joiner can result in foreign objects being thrown into your eyes, which can result in severe eye damage. Before beginning power tool operation, always wear safety goggles or safety glasses with side shields and a full face shield when needed. We recommend Wide Vision Safety Mask for use over eyeglasses or standard safety glasses with side shields, available at Sears Retail Stores. Always wear eye protection which is marked to comply with ANSI Z87.1.

SAVE THESE INSTRUCTIONS

FEATURES

Your Plate Joiner has been designed for making fast, accurate, and simple plunge cuts in wood, etc. so that biscuits can be used to join two or more boards together. When used properly and only for what it is intended, this versatile tool will give you years of trouble-free performance. It is professionally engineered, but its ease of operation allows the amateur to produce beautiful and precise work.

SWITCH

To turn your Plate Joiner **ON**, depress the switch trigger. Release switch trigger to turn your Plate Joiner **OFF**.

5/8 HP MOTOR

Your Plate Joiner has a powerful motor with sufficient power to handle tough cutting jobs. It develops a no load speed of 10,000 RPM.

BLADE

Your Plate Joiner has a 8-tooth carbide tipped blade for cutting biscuit slots.

BISCUITS

See Figure 1.

Biscuits are available in three standard sizes:

#0 (5/8 in. x 1-13/16 in.)

#10 (13/16 in. x 2-1/16 in.)

#20 (15/16 in. x 2-5/16 in.)

Note: Store biscuits in a dry place because they swell rapidly upon contact with water-based woodworking glues.

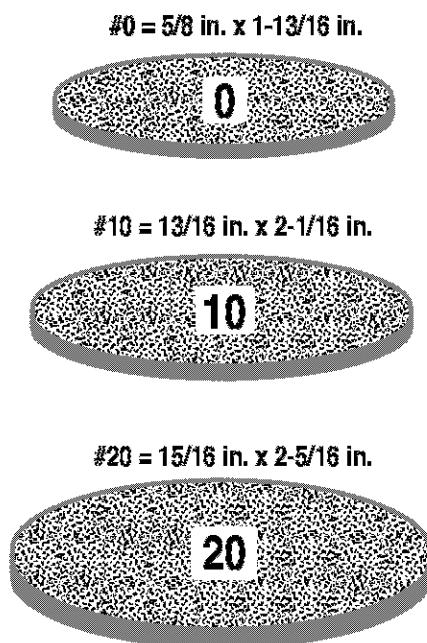

Fig. 1

ADJUSTABLE FENCE / FRONT HANDLE

Your plate joiner has an adjustable fence. By loosening the height adjustment knobs, the angle of the fence can be set up to 60° above and 45° below 90°, with positive stop settings in increments of 15°. The height of the fence can be set between 0 in. - 2 in. with a scale showing 0 in. - 1-1/2 in.

The front handle is part of the adjustable fence and should always be used to guide and balance your plate joiner, providing ease of operation and maintaining safe control.

NONSKID BACKING PAD

The fence on your Plate Joiner is padded with a nonskid backing pad to hold it stationary against the workpiece. It helps prevent skidding when making cuts. It also prevents marring of the workpiece from Plate Joiner when cutting.

INDICATOR MARKS

Centerline and line of cut indicator marks have been provided on your Plate Joiner. See Figure 2.

APPLICATIONS

(Use only for the purpose listed below)

- Cutting precise mating oval slots in hardwood, softwood, plywood, particle board, etc. for spline joinery applications.

DEPTH ADJUSTMENT KNOB

A spring loaded depth adjustment knob makes it possible to make proper settings for three standard size biscuits. Fine adjustments to the cutting depth can be made with a knurled adjustment knob and jam nut located behind the depth adjustment knob. Once the correct depth setting has been made for one biscuit size, the other two depth settings will be automatically set.

⚠ WARNING: Your Plate Joiner should never be connected to power supply when you are assembling parts, making adjustments, assembling or removing blades, cleaning or when not in use. Disconnecting your Plate Joiner will prevent accidental starting that could cause serious personal injury.

FEATURES

KNOW YOUR PLATE JOINER

See Figure 2.

Before attempting to use any tool familiarize yourself with all operating features and safety requirements.

ELECTRICAL CONNECTION

Your Plate Joiner has a precision built electric motor. It should be connected to a **power supply that is 120 volts, 60 Hz, AC only (normal household current)**. Do not operate this tool on direct current (DC). A substantial voltage drop will cause a loss of power and the motor will overheat. If your Plate Joiner does not operate when plugged into an outlet, double-check the power supply.

WARNING: Do not allow familiarity with tools to make you careless. Remember that a careless fraction of a second is sufficient to inflict severe injury.

WARNING: Do not attempt to modify this tool or create accessories not recommended for use with this tool. Any such alteration or modification is misuse and could result in a hazardous condition leading to possible serious personal injury.

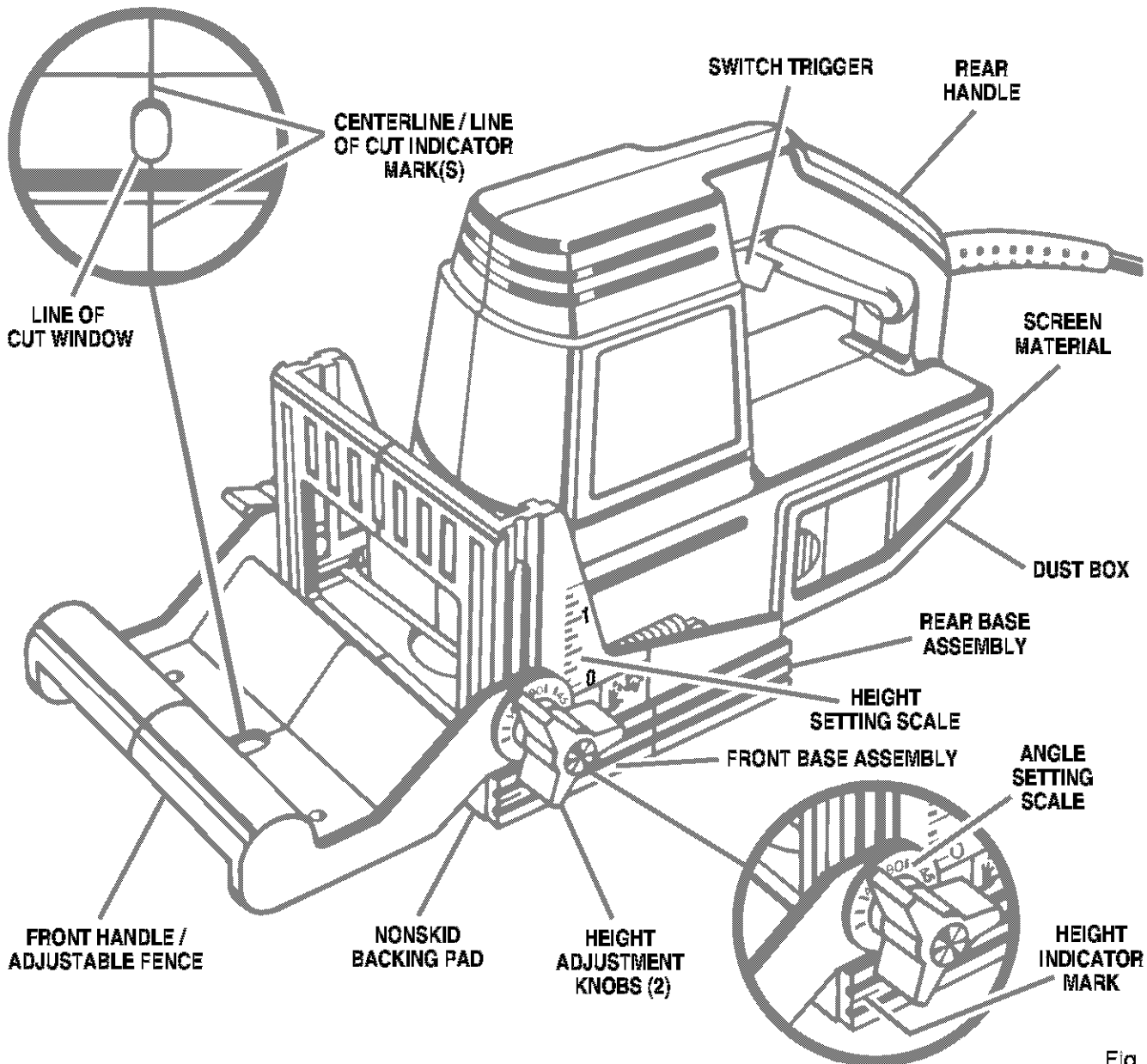

Fig. 2

ADJUSTMENTS

DEPTH OF CUT ADJUSTMENTS

Your Plate Joiner can be adjusted to three standard cutting depths to accommodate three standard size biscuits — #0, #10, and #20. Adjustments are made by engaging slots on depth adjustment knob with tabs on rear base. For example, when using a #0 size biscuit, rotate the depth adjustment knob until the slot marked 0 aligns with the depth indicator mark on the rear base. When using a #10 size biscuit, rotate the depth adjustment knob until the slot marked 10 aligns with the depth indicator mark on the rear base, and when using a #20 size biscuit rotate the depth adjustment knob until the slot marked 20 aligns with the depth indicator mark on the rear base. See Figure 3.

TO SET DEPTH ADJUSTMENT KNOB

- Unplug your Plate Joiner.

⚠ WARNING: Failure to unplug Plate Joiner could result in accidental starting causing possible serious personal injury.

- Pull knurled adjustment knobs in the direction of the arrow shown in figure 3.

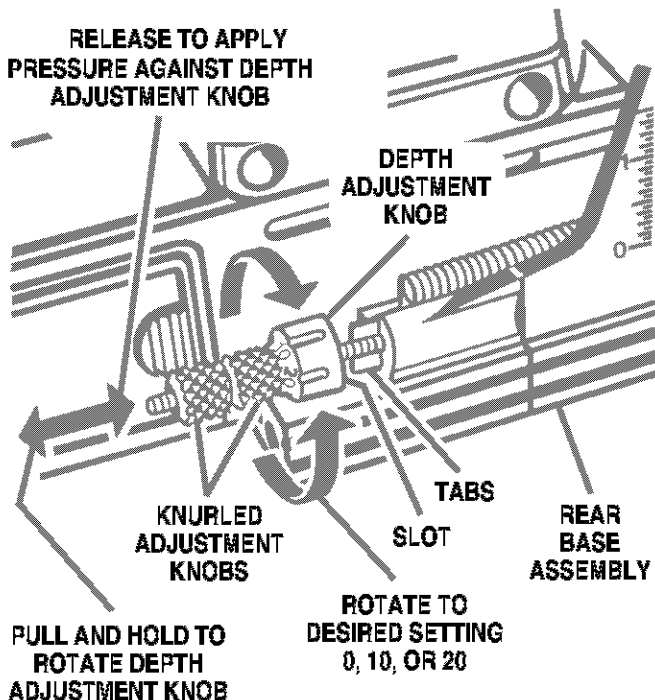

Fig. 3

Note: Knobs are spring loaded, therefore pulling them in the direction of the arrow shown puts pressure on the spring and releases pressure from the depth adjustment knob.

- Rotate depth adjustment knob until desired slot setting aligns with tabs on rear base — 0, 10, or 20.
- Next release knurled adjustment knob applying pressure from spring on depth adjustment knob.

Make a test cut in a scrap piece of wood. Fit the correct size biscuit into biscuit slot. If biscuit slot is too deep or too shallow, fine adjustments to the depth setting can be made by loosening rear adjustment knob and making fine adjustments with the front adjustment knob. Turning front knob forward will cut shallow biscuit slots. Turning front knob backwards will cut deeper biscuit slots. The biscuit slot should be deep enough to allow slightly more than one-half of the biscuit into the slot. This extra room allows for proper alignment of the wood being joined.

TO MAKE FINE ADJUSTMENTS

See Figure 4.

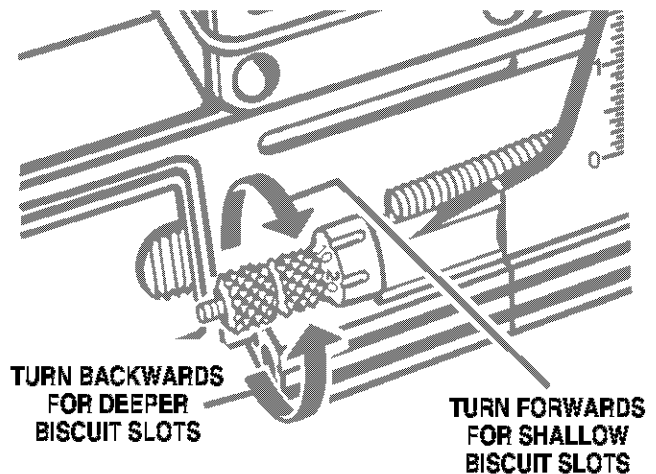

KNURLED ADJUSTMENT KNOBS: FRONT KNOB USED TO MAKE FINE ADJUSTMENTS REAR KNOB USED AS LOCK NUT OR JAM NUT.

Fig. 4

- Unplug your Plate Joiner.
- Loosen rear knurled adjustment knob. This knob is used as a lock nut only. Loosen by twisting it in the opposite direction away from front knob.
- Turn front knurled adjustment knob forward for a more shallow cut, or backwards for a deeper cut.
- Once desired depth of cut is reached, hold front knob so that it will not move out of adjustment. Next, tighten rear knob against front knob.
- Recheck depth setting by making a test cut in a scrap piece of wood. Also periodically check depth setting for accuracy. See Figure 4.

ADJUSTMENTS

FENCE HEIGHT ADJUSTMENT

See Figure 5.

The adjustable fence on your plate joiner can be moved up and down to adjust the position of the blade in relation to the top of the workpiece. A scale on both sides of the fence indicates the height of the fence from the center of the blade. The fence can be positioned up to two inches from the center of the blade. However, the scale and indicator point can only be set up to 1-1/2 in. from the center of the blade. Scale marks are in increments of 1/16 in.

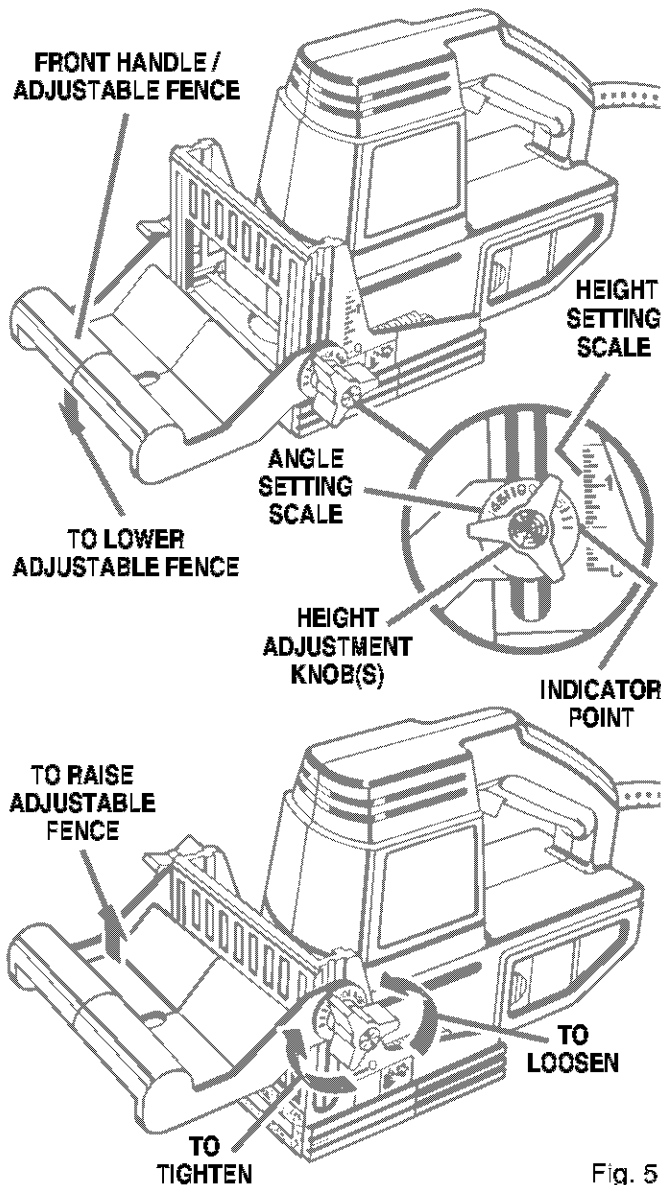

Fig. 5

TO ADJUST HEIGHT SETTING

See Figure 5.

- Unplug your Plate Joiner.

⚠ WARNING: Failure to unplug your Plate Joiner could result in accidental starting causing possible serious personal injury.

- Loosen the two height adjustment knobs.
Note: Loosen each height adjustment knob approximately one turn.

- Slide the fence up or down until the indicator point is aligned with the desired dimension on the scale.

- Tighten height adjustment knobs securely.

FENCE ANGLE ADJUSTMENT

See Figure 6.

The adjustable fence on your plate joiner can be set at angles ranging from 60° above 90° to 45° below 90°, with quick, accurate positive stops set in 15° increments. A scale is located on both sides of the front handle for identifying these positive stop angles. Each click you hear when rotating the adjustable fence from one angle setting to another equals a 15° positive stop angle change.

TO ADJUST ANGLE SETTING

See Figure 6.

- Unplug your Plate Joiner.
- Loosen the two height adjustment knobs.
Note: Loosen each height adjustment knob approximately one turn.
- Rotate adjustable fence up or down to the desired angle.
- Tighten height adjustment knobs securely. See Figure 6.

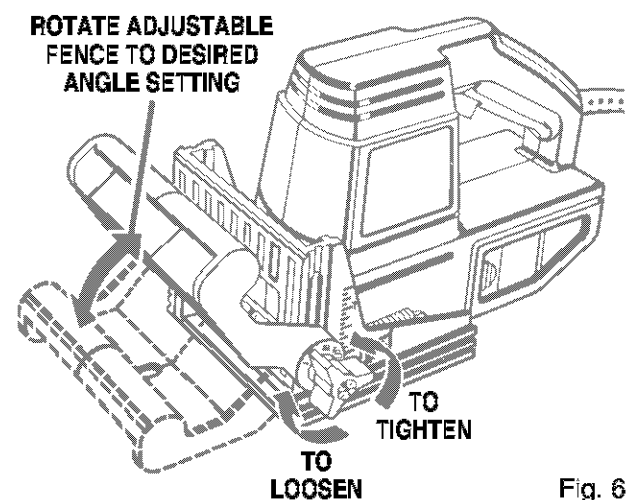

Fig. 6

OPERATION

WARNING: Always wear safety goggles or safety glasses with side shields when operating tools. Failure to do so could result in objects being thrown into your eyes, resulting in possible serious injury.

WARNING: Keep a firm grip on plate joiner with both hands at all times. Failure to do so could result in loss of control leading to possible serious injury.

A variety of spline joints can be made using your Biscuit Joiner. The number and size biscuits needed for each joint depends on the thickness of the wood and the length of the joint. In general, the small #0 biscuits should be used for miter cuts in 3/4 in. materials. The larger biscuits should be used for edge-to-edge joinery.

When joining 1-1/2 in. thick materials, stack two biscuits, one above the other. For example, joining 2 in. x 4 in. dressed lumber. See Figure 9. When joining even thicker materials, use additional biscuits, stacked above each other.

When making edge-to-edge joints the more biscuits you use, the stronger the joint will be. The following sections illustrate how to make various spline joints using your Plate Joiner.

EDGE-TO-EDGE JOINTS

See Figures 7 and 8.

Edge-to-edge joinery is one of the most basic and easiest joints to construct. In general, two basic adjustments have to be made for all biscuit joinery applications. One is the depth of cut and the other is the location of the cut.

HOW TO MAKE EDGE-TO-EDGE JOINTS

- Unplug your Plate Joiner.
- Prepare the workpieces by laying them side by side on a workbench in the order in which they will be assembled.
- Using a square, determine the location of each biscuit spline joint and mark the center of each joint by drawing a line across each workpiece. Mark edges 2 in. from the ends of workpieces. The joint will be stronger if you use multiple biscuits placed close together.
- Loosen height adjustment knobs and set fence angle at 90°.
- Slide the fence up or down until the indicator point is aligned with the desired dimension on the scale. **Remember:** The scale indicates the height of the fence from the center of blade.
- Tighten height adjustment knobs securely.
- Select the correct depth of cut setting to match the biscuit size you are planning to use. We suggest that you make a test cut in a scrap piece of wood from the same workpiece if possible.
- Clamp workpiece securely so it will not move during the cut.

- Plug your Plate Joiner into power supply and prepare to make your first cut. Grasp and hold your Plate Joiner securely.
- Place the fence against the board and align the indicator marks on the fence with the centerline mark(s) on the board. See Figure 7.

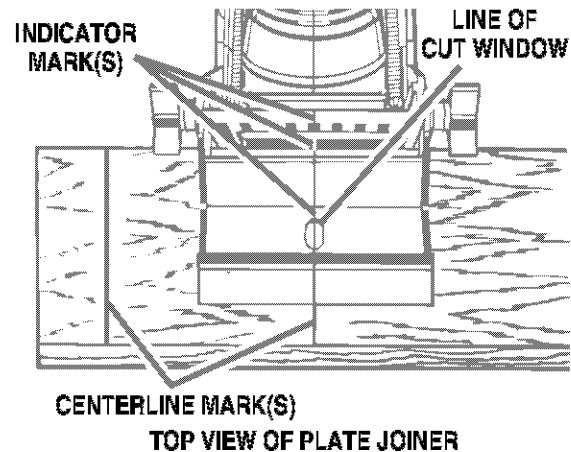

Fig. 7

- Depress the switch trigger and let the motor build to its maximum speed, then gradually push Biscuit Joiner forward to extend the blade into the wood.
- When the base assembly bottoms out against the depth of cut adjustment knob setting, pull back releasing pressure on the spring. Blade will retract from biscuit slot.
- Repeat this procedure for all desired biscuit slots and cutting the slots in the mating workpiece.
- Once all biscuit slots have been cut, place a biscuit in each joint and dry assemble the workpieces. Make sure each joint lines up and fits.
- Finally, disassemble the workpieces and place a bead of glue in each slot. Also, spread a bead of glue over the entire surface of the joint. Reinsert the biscuits and assemble the workpieces. See Figure 8.
- Clamp workpieces together until the glue sets up.

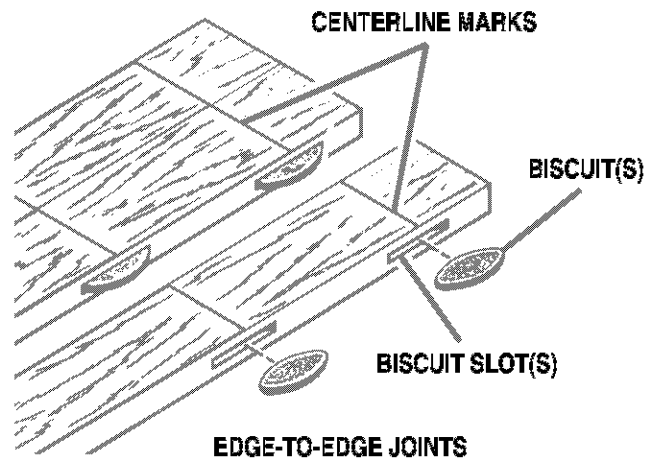

Fig. 8

BUTT JOINTS

See Figure 9.

A butt joint is one of the weakest joints in wood-working. This type of joint is mating the end grain of one board with the edge grain of another. The bonding of glue on this type of surface is poor. However, by using biscuits you can create a stronger joint that gives a mortise-and-tenon effect.

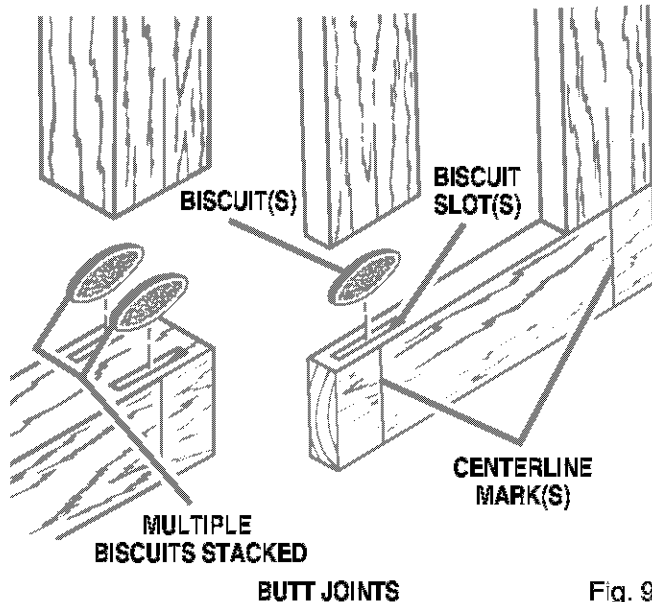

Fig. 9

HOW TO MAKE BUTT JOINTS

- Unplug your Plate Joiner.
- Place the two pieces of wood to be joined on a level workbench. Align them against each other in the arrangement in which they will be assembled.
- Using a square, determine the location of each biscuit spline joint and mark the center of each joint by drawing a line across the edges of the two boards.
- Loosen height adjustment knobs and set fence angle at 90°.
- Slide the fence up or down until the indicator point is aligned with the desired dimension on the scale. **Remember:** The scale indicates the height of the fence from the center of the blade.
- Tighten height adjustment knobs securely.
- Select the correct depth of cut setting to match the biscuit size you are planning to use. We suggest that you make a test cut in a scrap piece of wood from the same workpiece if possible.
- Clamp workpiece securely so that it will not move during the cut.
- Plug your Plate Joiner into power supply and prepare to make your first cut. Grasp and hold your Biscuit Joiner securely with both hands.

- Place the fence against the board and align the indicator marks on the fence with the centerline mark(s) on the board.
- Depress the switch trigger and let the motor build to its maximum speed, then gradually push Plate Joiner forward to extend the blade into the wood.
- When the base assembly bottoms out against the depth of cut adjustment knob setting, pull back releasing pressure on the spring. Blade will retract from biscuit slot.
- Repeat this procedure for cutting the slot in the mating workpiece.
- Once all biscuit slots have been cut, place a biscuit in each joint and dry assemble the workpieces. Make sure each joint lines up and fits.
- Finally, disassemble the workpieces and place a bead of glue in each slot. Also, spread a bead of glue over the entire surface of the joint. Reinsert the biscuits and assemble the workpieces. See Figure 9.
- Clamp workpieces together until the glue sets up.

OFFSET BUTT JOINTS

See Figure 10.

The rails of a table or workbench are often offset from the front of the table legs. When offsets are required, it is necessary to cut the slots in the rails first, then re-adjust the fence to cut the slots in the legs.

Keeping this one exception in mind, the procedure for cutting offset butt joints is identical to the procedure for cutting butt joints.

For example — If a 1/4 in. offset is desired, you would mark the centerlines for cutting a butt joint as mentioned in the procedures for cutting butt joints, and cut the slots in the ends of the rails. Next you would raise the fence 1/4 in. to the desired offset and cut the slots in the legs.

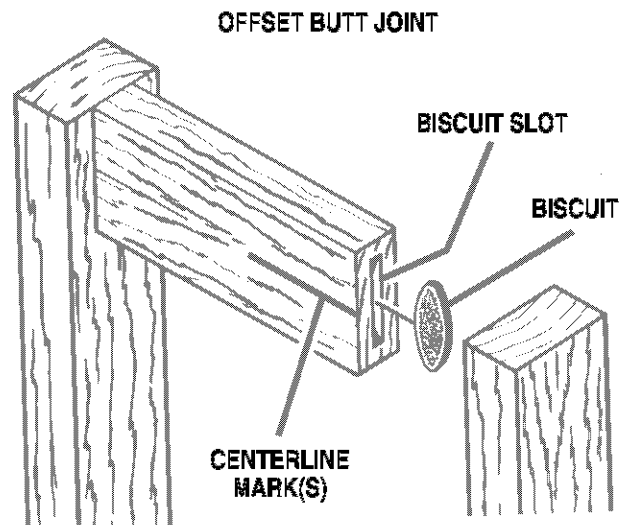

Fig. 10

OPERATION

T- JOINTS

See Figures 11-15.

A T-joint is used when the end of a board is joined to the face of another board as shown in figure 11. Attaching shelves to bookcases and inner support braces to frames are typical applications. Actual cutting of a T-joint is as simple as any other cut. However, it is critical that you mark the centerlines, mark the intersection points for each slot, and cut each slot correctly. See Figure 11.

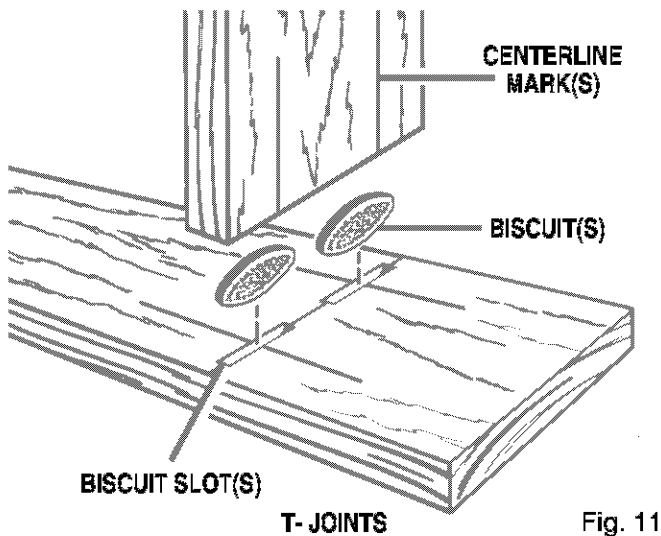

Fig. 11

HOW TO MAKE T- JOINTS

- Unplug your Plate Joiner.
- Place the two pieces of wood to be joined on a level workbench as shown in Figure 12. The inside face of the vertical board should be facing up.

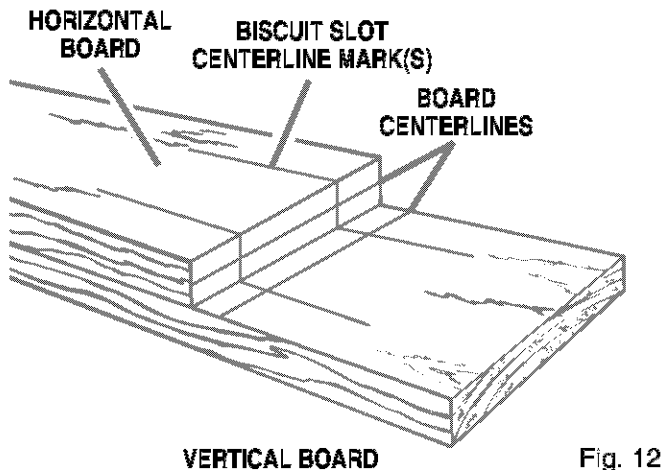

Fig. 12

- Determine the location of each biscuit joint and mark the centerlines on each board as shown. The centerlines for both boards must line-up with each other. Measure carefully, these measurements must be accurate and precise. **Tip:** Measure twice and cut once. In addition to the centerlines lining up, the spacing of the biscuit slots from side-to-side must also match.
- Plug your Plate Joiner into power supply and cut slots in all boards that require end slots. See Figure

13. Follow procedures explained in "Edge-To-Edge Joints". Set fence angle to 90°, set fence height at desired dimension on the scale, select the correct depth of cut setting for the biscuit size you plan to use, clamp workpiece securely, then cut each slot at the marked centerline intersection.

- Next, you must remove the fence from your Plate Joiner in order to cut slots into the face of the vertical board.

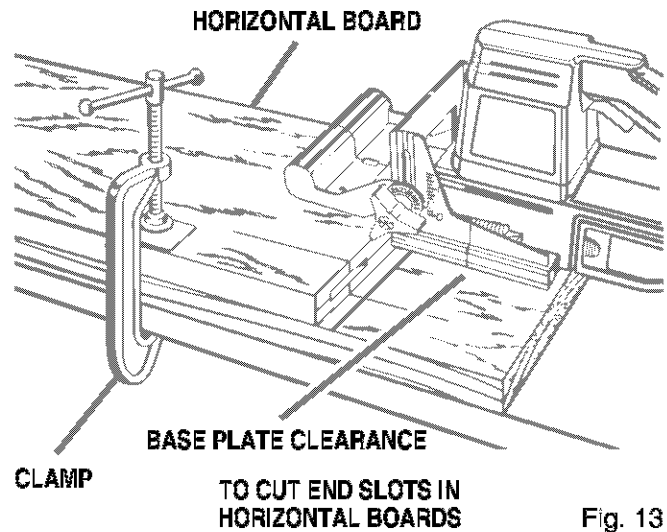

Fig. 13

TO REMOVE ADJUSTABLE FENCE:

- Unplug your Plate Joiner.
 - Loosen and remove height adjustment knobs, square head bolts, angle adjustment lock plates, and adjustable fence. See Figure 14.
- ⚠ WARNING:** When the fence is removed, the cutter may be exposed. Use extreme caution to avoid serious personal injury.

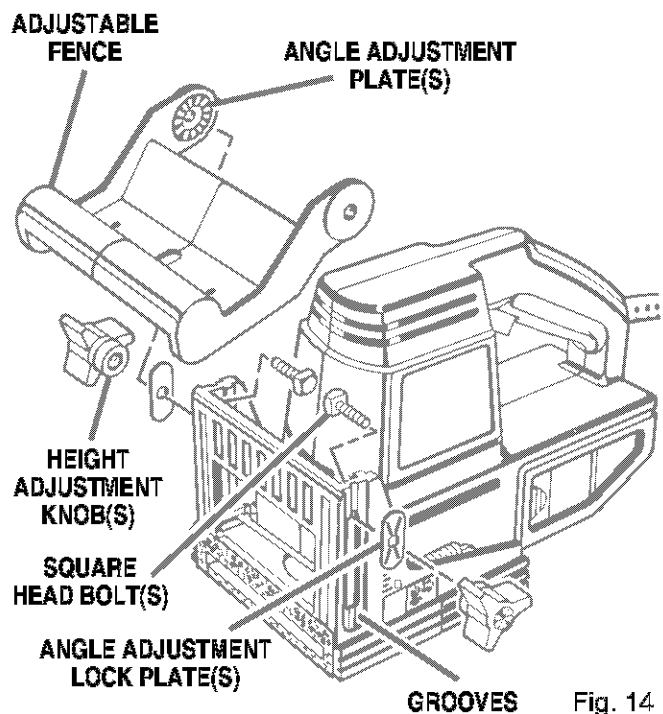
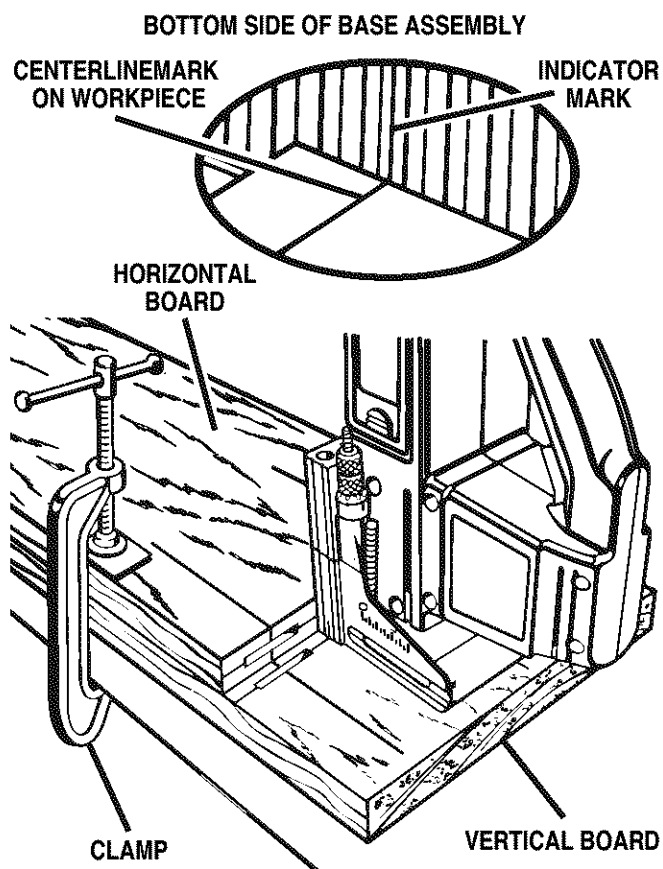

Fig. 14

OPERATION

T-JOINTS (Continued)

- Place your Plate Joiner on vertical board as shown in Figure 15 and align indicator marks on bottom shoe with centerline on vertical board.



TO CUT SLOTS IN VERTICAL BOARDS Fig. 15

- Place a straight piece of wood on the vertical board and securely clamp it flush against the bottom shoe. This piece of wood is used for a fence or guide. It must be square with the sides of the vertical board and parallel with the centerline.
- Align centerline on bottom of shoe with marked intersection for biscuit slot.
- Plug your Plate Joiner into power supply and prepare to cut slot.
- Depress the switch trigger and let the motor build to its maximum speed, then gradually push Plate Joiner forward to extend the blade into the wood.
- When the base assembly bottoms out against the depth of cut adjustment knob setting, pull back releasing pressure on the spring. Blade will retract from biscuit slot.
- Repeat this procedure for cutting all required slots in vertical boards.
- Once all slots have been cut, place a biscuit in each joint and dry assemble the workpieces. Make sure each joint lines up and fits.

- Finally, disassemble the workpieces and place a bead of glue in each slot. Also, spread a bead of glue over the entire surface of the joint. Reinsert the biscuits and assemble the workpieces. See Figure 11.

- Clamp workpieces together until the glue sets up.
- Upon completion of a T-joint cutting operation, reinstall the fence on the front base by reversing "TO REMOVE FENCE" procedure.** Place height adjustment knob bolts in key hole slots and align bolt heads with the slots on back of front base. Slide fence up the front base to desired depth of cut. Tighten height adjustment knobs securely.

MITER JOINTS

See Figures 16-19.

There are two types of miter joints that can be made using biscuits: flat miters and edge miters. Flat miters are used when making picture frames. Edge miters are used when making boxes or things where you don't want to show the end grain of the wood. Butt joints show the end grain in wood.

HOW TO MAKE FLAT MITER JOINTS

- Unplug your Plate Joiner.

WARNING: Failure to unplug your Plate Joiner could result in accidental starting causing possible serious personal injury.

- Place the pieces of wood to be joined on a level workbench as shown in Figure 16.

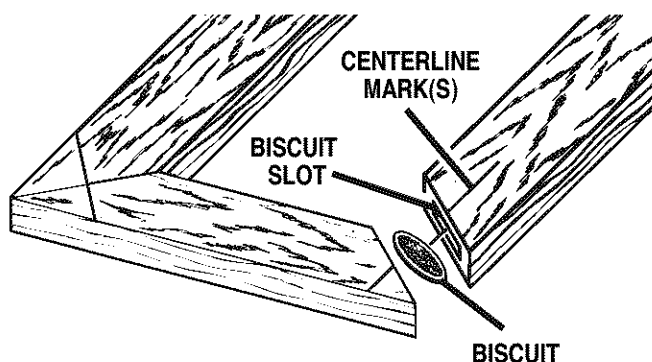

FLAT MITER JOINTS Fig. 16

- Using a combination square, draw a line through the center of each joint perpendicular to the mitered edges.
- Set fence angle at 90°, set fence height at desired dimension on the scale, select the correct depth of cut setting for the biscuit size you plan to use, and clamp workpiece securely.
- Align indicator mark on fence with the centerline on the workpiece.
- Plug your Plate Joiner into power supply and prepare to cut slot.

OPERATION

FLAT MITER JOINTS (Continued)

- Depress the switch trigger and let the motor build to its maximum speed, then gradually push Plate Joiner forward to extend the blade into the wood.
- When the base assembly bottoms out against the depth of cut adjustment knob setting, pull back releasing pressure on the spring. Blade will retract from biscuit slot.
- Repeat this procedure for cutting mating slot and all required miter joint slots.
- Once all slots have been cut, place a biscuit in each joint and dry assemble the workpieces. Make sure each joint lines up and fits.
- Finally, disassemble the workpieces and place a bead of glue in each slot. Also, spread a bead of glue over the entire surface of the joint. Reinsert the biscuits and assemble the workpieces. See Figure 16.
- Clamp workpieces together until the glue sets up.

HOW TO MAKE EDGE MITER JOINTS

- **Unplug your Plate Joiner.**
- Place the pieces of wood to be joined on a level workbench as shown in Figure 17.

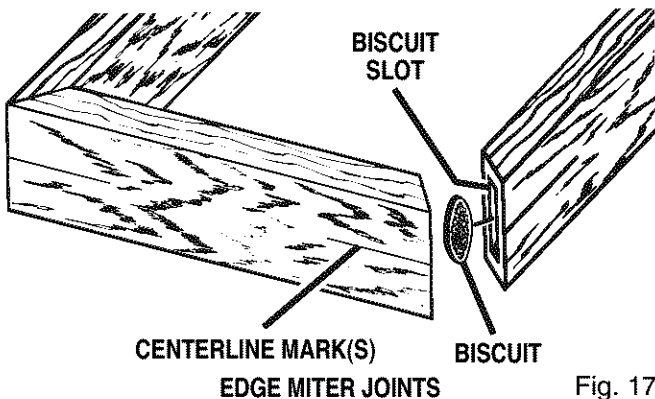

Fig. 17

- Mark centerline of the joint on each board.
- When making edge miter joints with workpieces that have different thicknesses, clamp securely to a workbench with the long sides up. This will assure that the outside surfaces will match. See Figure 18.
- Set fence angle at 45°.
- Slide the fence up or down until fence height is at desired setting.
- Tighten height adjustment knobs securely.
- Place your Plate Joiner on workpiece with the fence resting on the long side of workpiece as shown in Figure 18. The front base should be against the mitered edge of the workpiece.
- Recheck fence height setting to make sure it will not cut through the workpiece.
- Align indicator mark on fence with the centerline on the workpiece. Make sure the front base is pressed flat against the mitered edge of the workpiece.
- Plug your Plate Joiner into power supply and prepare to cut slot.

CUTTING EDGE MITER SLOT FROM LONG SIDE OF WORKPIECE

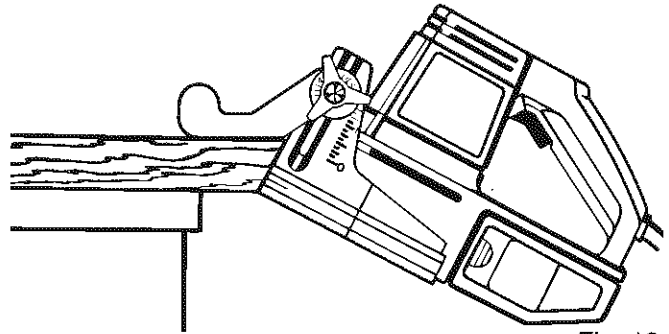

Fig. 18

- Depress the switch trigger and let the motor build to its maximum speed, then gradually push Biscuit Joiner forward to extend the blade into the wood.
- When the base assembly bottoms out against the depth of cut adjustment knob setting, pull back releasing pressure on the spring. Blade will retract from biscuit slot.
- Repeat this procedure for cutting mating slot and all required miter joint slots.
- Once all slots have been cut, place a biscuit in each joint and dry assemble the workpieces. Make sure each joint lines up and fits.
- Finally, disassemble workpieces and place a bead of glue in each slot. Also, spread a bead of glue over the entire surface of the joint. Reinsert the biscuits and assemble workpieces. See Figure 17.
- Clamp workpieces together until the glue sets up.

If the workpieces are the same thickness, clamp securely to a workbench with the short sides up. See Figure 19. Set fence angle at 45°. Place your plate joiner on the workpiece with the adjustable fence resting on the short side of the workpiece and the base or vertical fence against the mitered edge of the workpiece. Follow steps 9-17 above to cut required slots. **REMEMBER:** Before cutting slots, make sure blade will not cut through the workpiece and that both the vertical and horizontal fences are pressed flat against the mitered edge and face of the workpiece.

CUTTING EDGE MITER SLOT FROM SHORT SIDE OF WORKPIECE

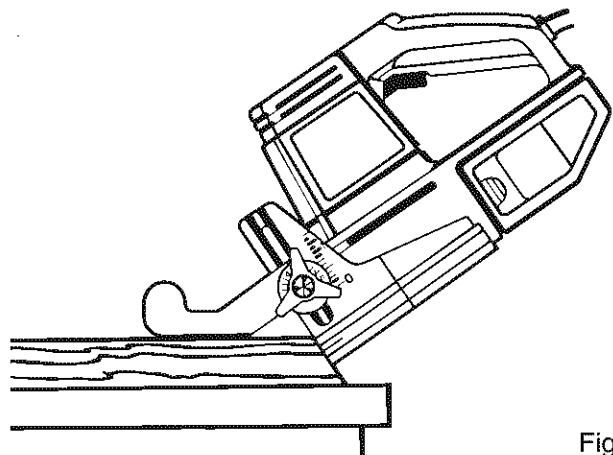

Fig. 19

OPERATION

AUXILIARY FENCE

See Figures 20-21.

When cutting biscuit slots in workpieces less than 1-1/2 in. wide, it is necessary to make an auxiliary fence and mount it to the bottom of the adjustable fence. This fence will provide a positive stop for the height setting of these small workpieces.

HOW TO MAKE AUXILIARY FENCE

- Unplug your plate joiner.
- Cut a thin piece of wood 3-5/8 in. x 5-1/4 in.
Note: The thickness of the wood will cause the scale on the vertical fence of your plate joiner to be incorrect. Height adjustment settings must allow for the thickness of the auxiliary fence when preparing to cut slots.
- Cut a notch as shown in figure 20 for viewing indicator mark and centerline markings on boards.

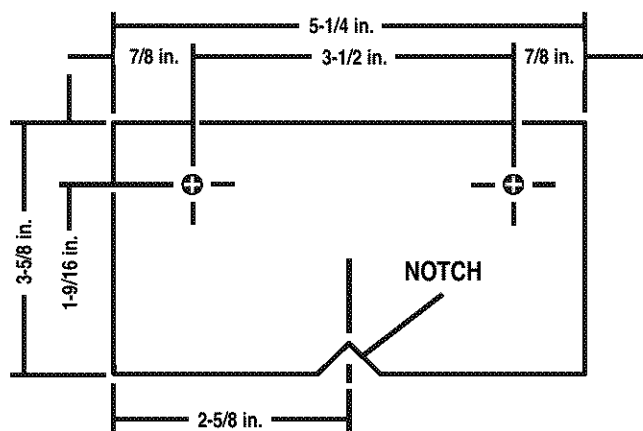

AUXILIARY FENCE

Fig. 20

- Place auxiliary fence against bottom of adjustable fence. See Figure 21.
- Using screw holes in adjustable fence for a pattern, mark screw hole locations on auxiliary fence. **Note:** See figure 20 for screw hole locations and dimensions.
- Drill 3/16 in. screw holes in auxiliary fence. Screw holes must be countersunk on the bottom so that screwheads will be flush with or below the surface of the auxiliary fence.
- Secure auxiliary fence to adjustable fence with 3/16 in. x 3/4 in. flat head machine screws, washers, and hex nuts as shown in figure 21.
- Tighten screws securely, making sure screw heads are flush or subflush with bottom surface of auxiliary fence.

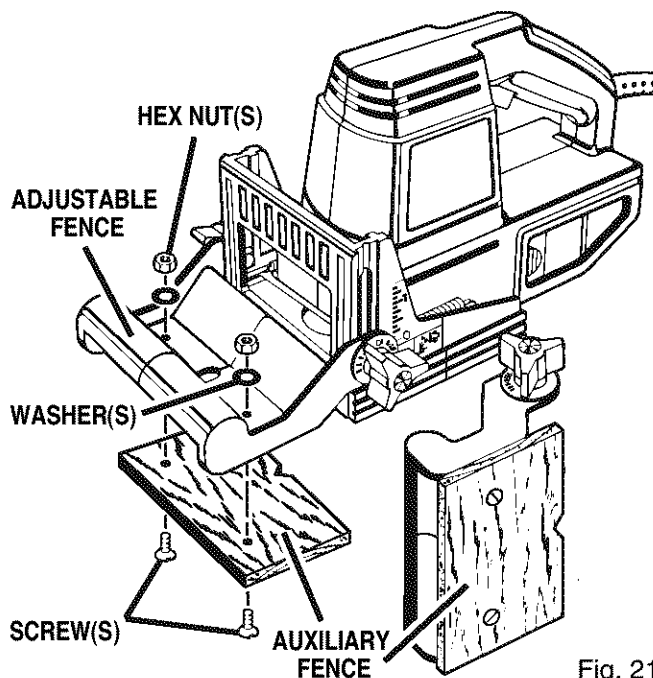

Fig. 21

DUSTLESS FEATURE

The dust box located on the rear of your plate joiner provides a dust collection system. Wood particles are drawn up through a tunnel in the base and collect in the dust box during cutting operations. For more efficient operation, empty dust box when half full.

TO REMOVE DUST BOX FOR EMPTYING

See Figure 22.

- Unplug your plate joiner.

WARNING: Failure to unplug your plate joiner could result in accidental starting causing possible serious personal injury.

- To release dust box, depress tabs located on each side of dust box as shown by the arrows in figure 22.

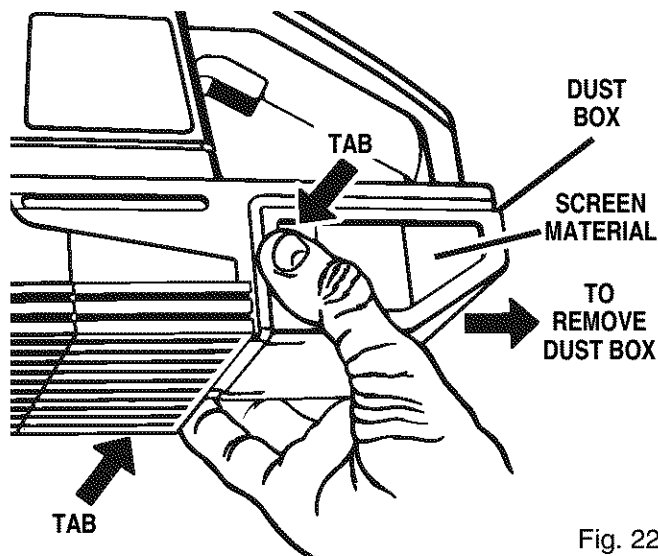

Fig. 22

OPERATION

- Slide dust box to the rear of plate joiner as shown by the arrow in figure 22, and remove.
- **Do not** press on the screen material with your hand or fingers. Screen material can be damaged.
Note: Screen material is located on the sides and rear of dust box.
- **Do not** break tabs that secure dust box to plate joiner.
- Empty dust box.

TO INSTALL DUST BOX

See Figure 23.

- Unplug your plate joiner.

WARNING: Failure to unplug your plate joiner could result in accidental starting causing possible serious personal injury.

- Realign dust box with rear of plate joiner. Grooves in dust box align with rails on plate joiner.

- Slide dust box on plate joiner as shown by the arrow in figure 23. You will feel a soft click as the tabs snap into place.

Note: As mentioned, be careful not to break the tabs that secure dust box to plate joiner.

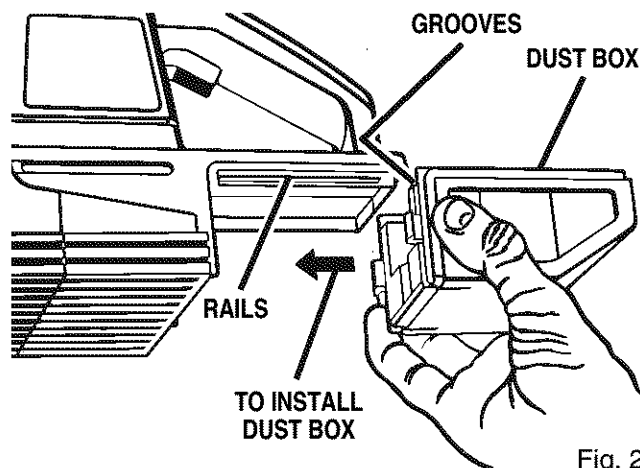

Fig. 23

MAINTENANCE

WARNING: When servicing, use only identical Craftsman replacement parts. Use of any other part may create a hazard or cause product damage.

GENERAL

Only the parts shown on parts list, page 23, are intended to be repaired or replaced by the customer. All other parts represent an important part of the double insulation system and should be serviced only by a qualified Sears service technician.

Avoid using solvents when cleaning plastic parts. Most plastics are susceptible to damage from various types of commercial solvents and may be damaged by their use. Use clean cloths to remove dirt, carbon dust, etc.

WARNING: Do not at any time let brake fluids, gasoline, petroleum-based products, penetrating oils, etc. come in contact with plastic parts. They contain chemicals that can damage, weaken or destroy plastic.

It has been found that electric tools are subject to accelerated wear and possible premature failure when they are used on fiberglass boats, sports cars, wallboard, spackling compounds, or plaster. The chips and grindings from these materials are highly abrasive to electric tool parts such as bearings, brushes, commutators, etc. Consequently, it is not recommended that this tool be used for extended work on any fiberglass material, wallboard, spackling compounds, or plaster. During any use on these materials it is extremely important that the tool is cleaned frequently by blowing with an air jet.

WARNING: Always wear safety goggles or safety glasses with side shields during power tool operation or when blowing dust. If operation is dusty, also wear a dust mask.

EXTENSION CORDS

The use of any extension cord will cause some loss of power. To keep the loss to a minimum and to prevent tool overheating, use an extension cord that is heavy enough to carry the current the tool will draw.

A wire gage size (A.W.G.) of at least **16** is recommended for an extension cord 100 feet or less in length. When working outdoors, use an extension cord that is suitable for outdoor use. The cord's jacket will be marked **WA**.

CAUTION: Keep extension cords away from the cutting area and position the cord so that it will not get caught on lumber, tools, etc., during cutting operation.

WARNING: Check extension cords before each use. If damaged replace immediately. Never use tool with a damaged cord since touching the damaged area could cause electrical shock resulting in serious injury.

Extension cords suitable for use with your Plate Joiner are available at your nearest Sears Retail Store.

LUBRICATION

All of the bearings in this tool are lubricated with a sufficient amount of high grade lubricant for the life of the unit under normal operating conditions. Therefore, no further lubrication is required.

MAINTENANCE

BLADE REPLACEMENT

See Figures 24-27.

After extended use, the blade on your Plate Joiner may become dull. If you accidentally hit a nail or other blunt object, it will dull or break the blade. These situations require replacing the blade.

HOW TO REPLACE THE BLADE

- Unplug your plate joiner.

⚠ WARNING: Failure to unplug your Plate Joiner could result in accidental starting causing possible serious personal injury.

- Remove dust box.
- Place your plate joiner upside down on a workbench as shown in figure 24.

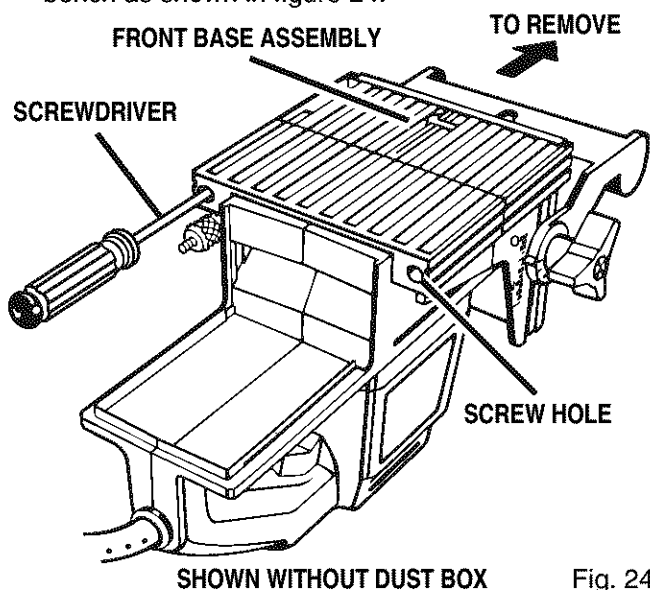

Fig. 24

- Using a screwdriver remove the two screws securing front base assembly.
- Pull adjustable fence in the direction shown by the arrow in figure 24 and remove front base assembly.

⚠ WARNING: If inner blade washer has been removed, replace it before installing new blade. Failure to do so could cause an accident since blade screw will not tighten properly.

- Using a pair of needle nose pliers, stretch and release springs from tabs on bearing plate. See Figure 25.
- Push adjustment rod away from bearing plate and remove rear base assembly.
- With base assemblies removed, place plate joiner upside down on a workbench as shown in figure 26.
- Place a #2 Phillips screwdriver or 1/4 in. diameter pin in one of the two holes provided in bearing plate.
- Place one of the non-cutting teeth located behind each carbide tipped cutting tooth against the screwdriver or pin and lock blade preventing it from

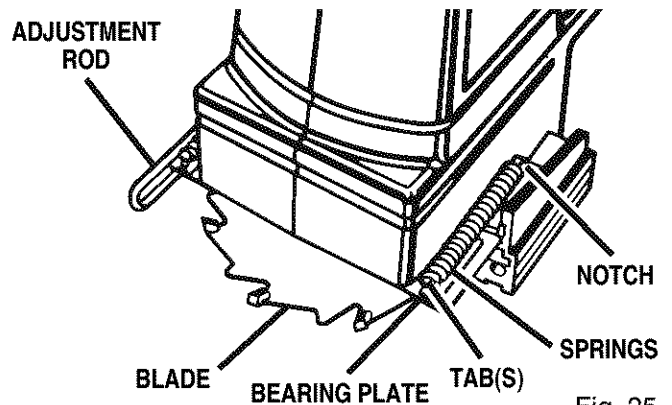

Fig. 25

rotating. **DO NOT lock blade against one of the cutting teeth. Carbide tips will break.**

- Using a 3/16 in. wrench, remove blade screw. **Note:** Turn blade screw counterclockwise to remove. See Figure 27.
- Remove outer blade washer and blade.
- Clean wood particles and resin from blade washer, dust bag area, base assembly slots, and all surrounding parts.

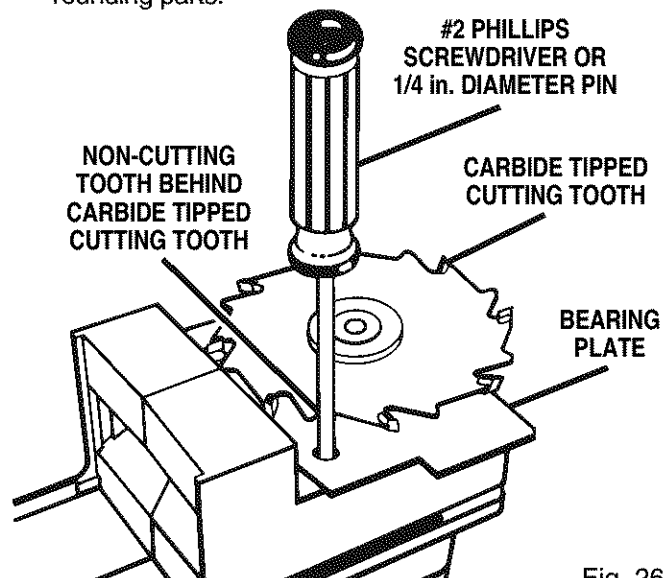

Fig. 26

- Place inner blade washer on gear spindle. See Figure 27.
- Place new blade onto shoulder of blade washer and secure with outer blade washer and blade screw. **Note:** Blade screw fits into cupped side of outer blade washer. **Note:** Blade teeth point toward the right of the saw when held in normal operating position. The direction of rotation is marked on the saw blade. An arrow on the bottom of the front base assembly also indicates direction of rotation.
- Tighten blade screw securely. **Note:** Turn blade screw clockwise to tighten.
- Replace rear base assembly. Position adjustment rod in its proper place as shown in figure 25.

MAINTENANCE

- Secure rear base assembly in place with the two springs. Hook one end of each spring in notch on each side of base assembly. Using needle nose pliers, stretch each spring and hook it over tabs on bearing plate.
- Reassemble front base assembly.
- Replace screws and tighten securely with a screwdriver.
- Replace dust box.

⚠ WARNING: When servicing, use only identical Craftsman replacement parts. Use of any other part may create a hazard or cause product damage.

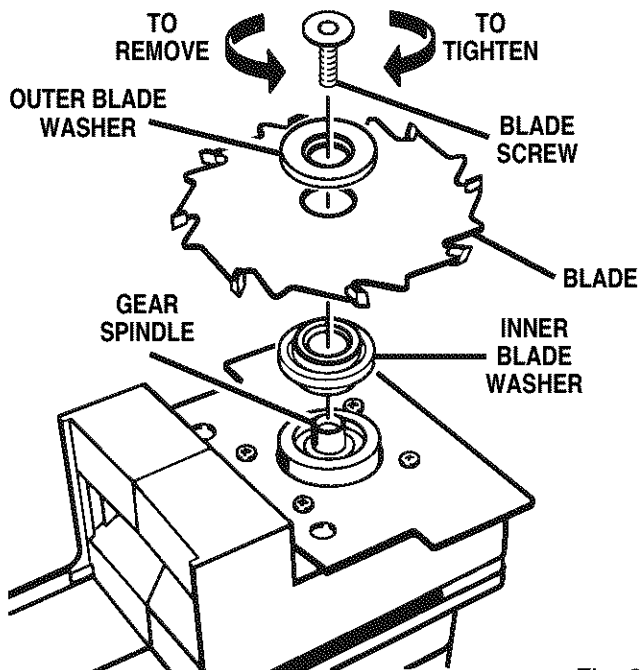

Fig. 27

CLEANING BASE ASSEMBLY/ DUST BOX TUNNEL

After extended use, wood particles and resin may build up inside the base assembly of your Plate Joiner and clog the path for wood particles going through dust exhaust opening. Wood particles packing up in this area makes cutting biscuit slots more difficult.

HOW TO CLEAN BASE ASSEMBLY

- Unplug your plate joiner.

⚠ WARNING: Failure to unplug your Plate Joiner could result in accidental starting causing possible serious personal injury.

- Remove dust box.

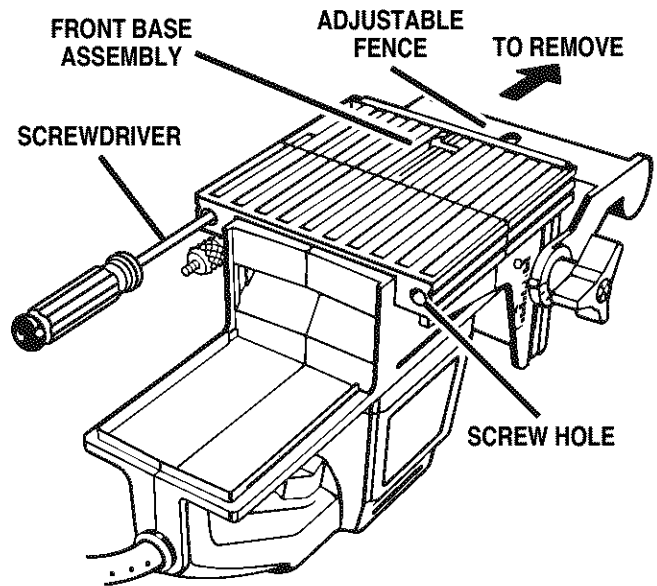

SHOWN WITHOUT DUST BOX

Fig. 28

- Place your plate joiner upside down on a workbench as shown in figure 28.
- Using a screwdriver remove the two screws securing front base assembly.
- Pull adjustable fence in the direction shown by the arrow in figure 28 and remove front base assembly.
- Using a pair of needle nose pliers, stretch and release springs from tabs on bearing plate. See Figure 29.
- Push adjustment rod away from bearing plate and remove rear base assembly.
- With front and rear base assemblies removed, place your plate joiner upside down on a workbench and clean wood particles and resin from blade, bearing plate and surrounding areas.

⚠ CAUTION: Be aware of cut hazard, carbide tips on blade are sharp.

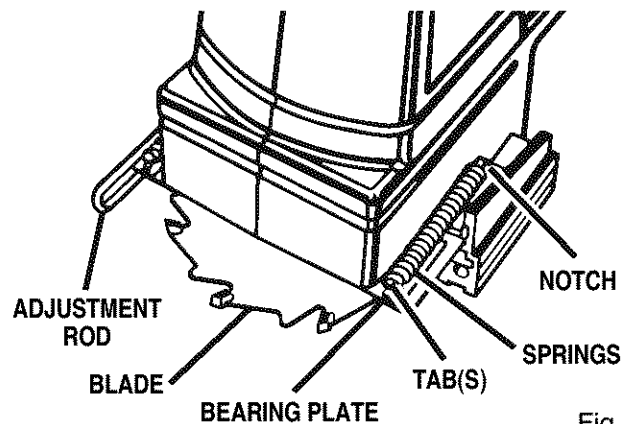

Fig. 29

MAINTENANCE

- Clean wood particles and resin from slots and surrounding areas on front and rear base assemblies. See Figure 30. Apply a thin coat of general purpose grease in slots or on bearing plate where base slides.
- Replace rear base assembly. Position adjustment rod in its proper place as shown in figure 29.
- Secure rear base assembly in place with the two springs. Hook one end of each spring in notch on each side of base assembly. Using needle nose pliers, stretch each spring and hook it over tabs on bearing plate.
- Reassemble front base assembly.
- Replace screws and tighten securely with a screwdriver.
- Replace dust box.

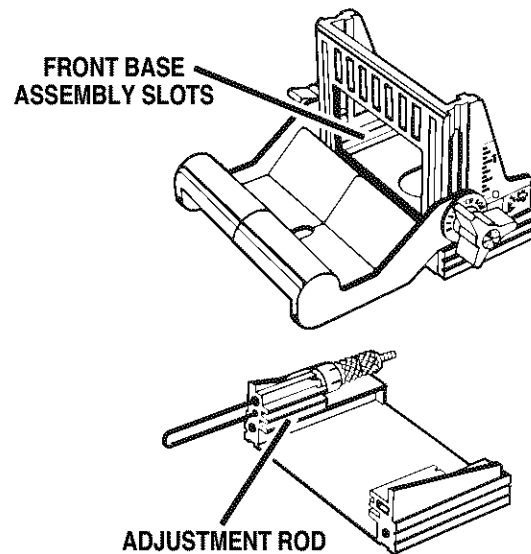

Fig. 30

HELPFUL HINTS

- ✓ Always clamp workpiece securely before cutting.
- ✓ A safe operator is one who thinks ahead.
- ✓ Always wear eye protection when cutting slots.
- ✓ Make set-up adjustments carefully. Then double check. Measure twice and cut once.
- ✓ Always dry assemble your project before gluing it together.
- ✓ For loose fit situations, wet biscuits to make them swell.
- ✓ The more biscuits used, the stronger the joint will be.
- ✓ Keep blade clean. When the blade becomes dull, replace it.
- ✓ Don't let familiarity make you careless.
- ✓ Study all safety rules and do the job safely.
- ✓ **Never** place your hands in jeopardy.
- ✓ Make certain clamps can't loosen while in use.
- ✓ Test difficult set-ups on scrap—Don't waste lumber.
- ✓ Plan each operation before you begin.
- ✓ Provide for smoother operation by cleaning your Biscuit Joiner frequently. Shake Biscuit Joiner or blow with an air jet to remove wood particle build-up.
- ✓ **Do not abuse power tools.** Abusive practices can damage tool as well as workpiece.
- ✓ **Think safety by thinking ahead.**

TROUBLESHOOTING

PROBLEM

SOLUTION

1. Biscuits do not fit slots. Biscuits not fitting slots may also cause misalignment of boards being joined.

- A. Biscuit slots are too deep or too shallow. Make fine adjustments to depth setting. See "**TO MAKE FINE ADJUSTMENTS**" section on page 9.
- B. Biscuit thickness may be out of tolerance. Compress biscuits in a vise if they are too thick.
- C. Check to see if biscuits are the correct size for the size slots that have been cut: #0, #10, or #20.
- D. Check to see if biscuits have gotten wet and swollen.
- E. If biscuits fit loose in slots, wet them to take up the loose fit.

2. Wood particles begin to backup on front of unit.

- A. Dust exhaust may be clogged preventing wood particles from going through dust exhaust opening. Remove bottom shoe and clean blade, bearing plate, base assembly slots, and surrounding areas. See "**CLEANING BASE ASSEMBLY**" section on pages 19-20.

3. Blade becomes difficult to push in when cutting slots. Blade does not retract properly when cutting slots.

- A. Wood particles and resin have built up on base assembly slots and surrounding areas. Remove front and rear base assemblies and clean blade, bearing plate, base assembly slots and surrounding areas. Apply a thin coat of general purpose grease in slots or on bearing plate where base slides. See "**CLEANING BASE ASSEMBLY**" section on pages 19-20.

4. Cutting performance is poor and there is a loss of power or stalling of motor when cutting slots.

- A. Blade is dull. Replace blade. See "**BLADE REPLACEMENT**" section on pages 18-19.
- B. Resin has built up on blade. Remove blade and clean it with gum and pitch remover. See "**BLADE REPLACEMENT**" section on pages 18-19 for blade removing instructions. Once clean, follow "**BLADE REPLACEMENT**" instructions to replace the blade.

CRAFTSMAN PLATE JOINER – MODEL NO. 315.175011

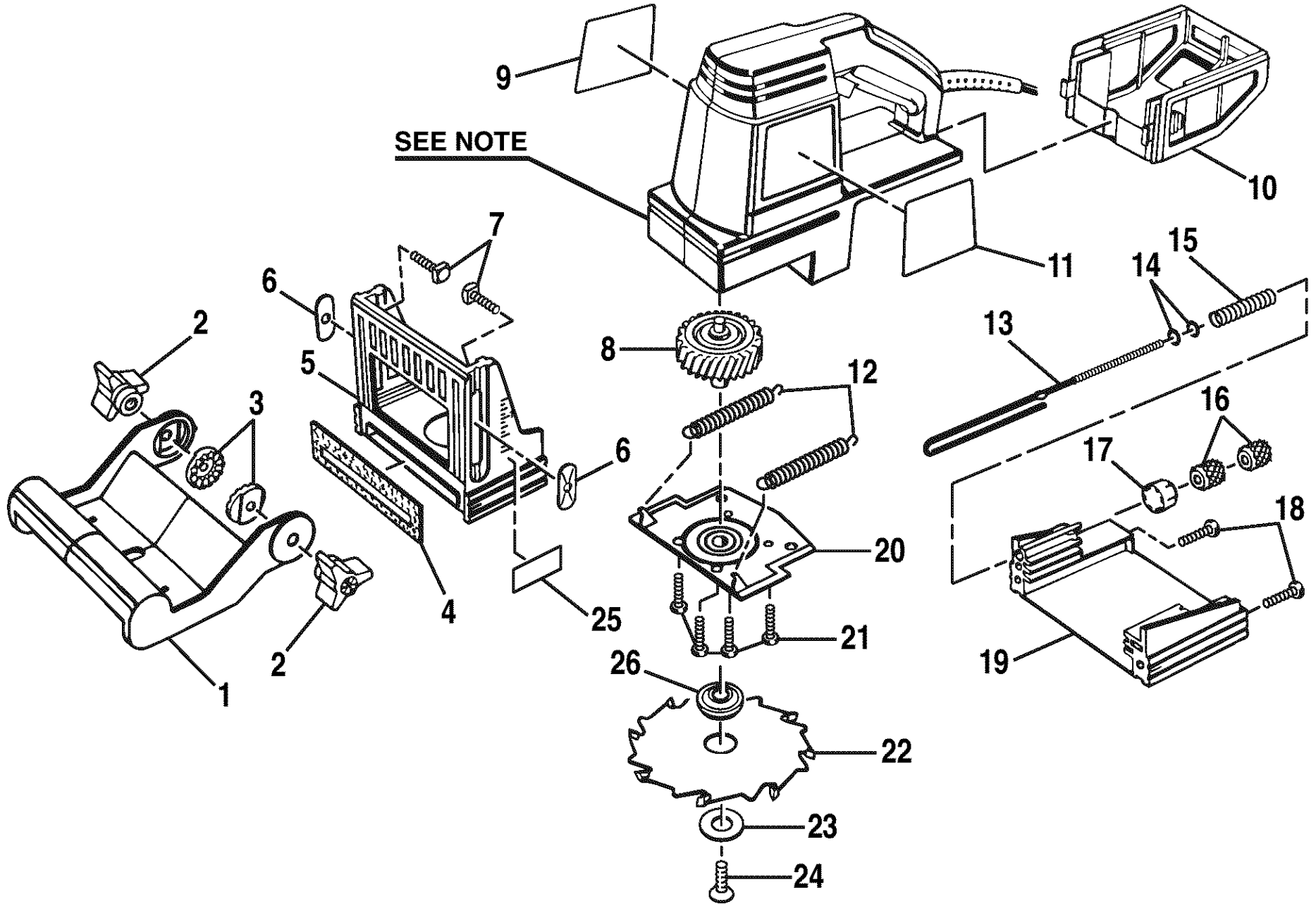

SEE NOTE

NOTE: The assembly shown represents an important part of the Double Insulated System. To avoid the possibility of alteration or damage to the system, service should be performed by your nearest Sears Repair Center. Contact your nearest Sears retail store for service center information.

CRAFTSMAN PLATE JOINER – MODEL NO. 315.175011

The model number will be found on a plate attached to the motor housing. Always mention the model number in all correspondence regarding your **PLATE JOINER** or when ordering repair parts.

SEE BACK PAGE FOR PARTS ORDERING INSTRUCTIONS

PARTS LIST

Key No.	Part Number	Description	Qty.
1	971484-001	Adjustable Fence / Front Handle	1
2	999529-001	Height Adjustment Knob	2
3	971503-002	Angle Adjustment Plate	2
4	971483-001	Non-Skid Backing Pad	1
5	971479-001	Front Base	1
6	971508-002	Angle Adjustment Lock Plate	2
7	623166-002	Bolt (1/4-20 x 3/4 in. Sq. Hd.)	2
8	972715-000	Gear And Spindle Assembly	1
9	983168-001	Data Plate	1
10	971475-001	Dust Box	1
11	981244-001	Logo Plate	1
12	971496-001	Spring	2
13	971473-001	Adjustment Rod	1
14	931868-008	Washer	2
15	971499-001	Compression Spring	1
16	971498-001	Knurled Adjustment Knob	2
17	971497-001	Depth Adjustment Knob	1
18	623275-003	* Screw (10-24 x 3/4 in. Fil. Hd.)	2
19	971480-001	Rear Base	1
20	972714-000	Bearing Plate with Bearing	1
21	968703-011	* Screw (8-32 x 3/4 in. Pan Hd.)	4
22	971478-001	*** Blade	1
23	973606-001	Outer Blade Washer	1
24	975100-001	Blade Screw (Includes Key No. 23)	1
25	983167-001	Warning Label	1
26	973604-001	Inner Blade Washer	1
	972000-979	Operator's Manual	

* Standard Hardware Item – May Be Purchased Locally

*** Complete Assortment Available At Your Nearest Sears Retail Store

Get it fixed, at your home or ours!

Your Home

For repair – **in your home** – of **all** major brand appliances, lawn and garden equipment, or heating and cooling systems, **no matter who made it, no matter who sold it!**

For the replacement parts, accessories and owner's manuals that you need to do-it-yourself.

For Sears professional installation of home appliances and items like garage door openers and water heaters.

1-800-4-MY-HOME[®] (1-800-469-4663)

Call anytime, day or night (U.S.A. and Canada)

www.sears.com www.sears.ca

Our Home

For repair of carry-in items like vacuums, lawn equipment, and electronics, call or go on-line for the location of your nearest **Sears Parts & Repair Center.**

1-800-488-1222

Call anytime, day or night (U.S.A. only)

www.sears.com

To purchase a protection agreement (U.S.A.) or maintenance agreement (Canada) on a product serviced by Sears:

1-800-827-6655 (U.S.A.)

1-800-361-6665 (Canada)

Para pedir servicio de reparación a domicilio, y para ordenar piezas:

1-888-SU-HOGARSM
(1-888-784-6427)

Au Canada pour service en français:

1-800-LE-FOYER^{MC}
(1-800-533-6937)
www.sears.ca

SEARS