

Owner's Manual

CRAFTSMAN®

PROFESSIONAL

8-1/4 in., 18 VOLT PROFESSIONAL CORDLESS COMPOUND MITER / TRIM SAW

Model No.
315.212180

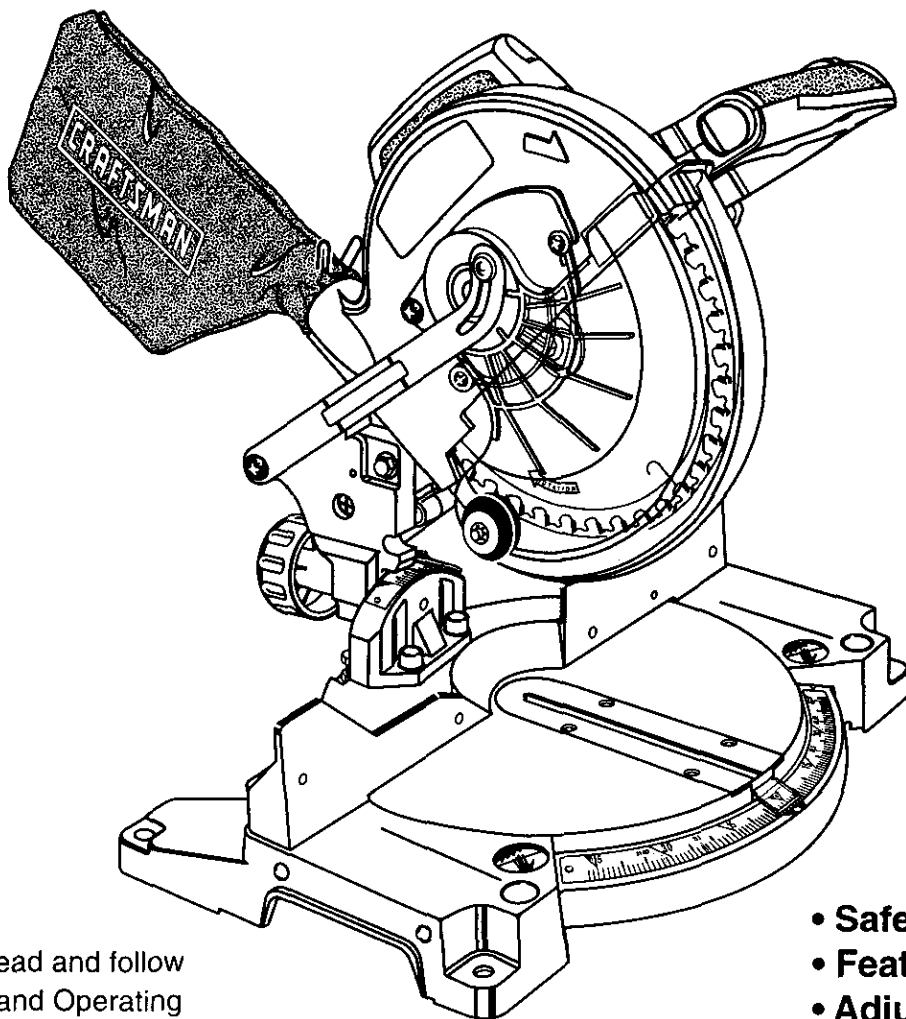

Save this manual for
future reference

⚠ CAUTION: Read and follow
all Safety Rules and Operating
Instructions before first use of
this product.

Customer Help Line: 1-800-932-3188

Sears, Roebuck and Co., Hoffman Estates, IL 60179 USA
Visit the Craftsman web page: www.sears.com/craftsman

972000-841
5-01

- Safety
- Features
- Adjustments
- Operation
- Maintenance
- Parts List



TABLE OF CONTENTS

■ Table of Contents	2
■ Warranty and Introduction	2
■ Rules For Safe Operation	3-7
■ Glossary	7
■ Product Specifications and Unpacking	8
■ Labels	9
■ Loose Parts and Tools Needed	10
■ Battery Pack and Charging Information	11
■ Features	12-15
■ Adjustments	16-23
■ Operation	24-31
■ Maintenance	32
■ Exploded View and Repair Parts List	34-39
■ Parts Ordering / Service	40

WARRANTY

FULL ONE YEAR WARRANTY ON CRAFTSMAN PROFESSIONAL MITER / TRIM SAW

If this **CRAFTSMAN** Miter / Trim Saw fails due to a defect in material or workmanship within one year from the date of purchase, Sears will repair it free of charge.

WARRANTY SERVICE IS AVAILABLE BY SIMPLY RETURNING THE TOOL TO THE NEAREST SEARS STORE OR OTHER CRAFTSMAN OUTLET IN THE UNITED STATES.

This warranty gives you specific legal rights, and you may also have other rights which vary from state to state.

Sears, Roebuck and Co., Dept. 817 WA, Hoffman Estates, IL 60179

INTRODUCTION

Your saw has many features for making cutting operations more pleasant and enjoyable. Safety, performance and dependability have been given top priority in the design of this saw making it easy to maintain and operate.

CAUTION: Carefully read through this entire owner's manual before using your new saw. Pay close attention to the Rules For Safe Operation, and all Safety Alert Symbols including Danger, Warning and Caution. If you use your saw properly and only for what it is intended, you will enjoy years of safe, reliable service.

! Look for this symbol to point out important safety precautions. It means attention!!! Your safety is involved.

! WARNING:



The operation of any power tool can result in foreign objects being thrown into your eyes, which can result in severe eye damage. Before beginning power tool operation, always wear safety goggles or safety glasses with side shields and a full face shield when needed. We recommend Wide Vision Safety Mask for use over eyeglasses or standard safety glasses with side shields, available at Sears Retail Stores.

RULES FOR SAFE OPERATION

The purpose of safety symbols is to attract your attention to possible dangers. The safety symbols, and the explanations with them, deserve your careful attention and understanding. The safety warnings do not by themselves eliminate any danger. The instructions or warnings they give are not substitutes for proper accident prevention measures.

SYMBOL MEANING



SAFETY ALERT SYMBOL:

Indicates danger, warning or caution. May be used in conjunction with other symbols or pictographs.



DANGER: Failure to obey a safety warning will result in serious injury to yourself or to others. Always follow the safety precautions to reduce the risk of fire, electric shock and personal injury.



WARNING: Failure to obey a safety warning can result in serious injury to yourself or to others. Always follow the safety precautions to reduce the risk of fire, electric shock and personal injury.



CAUTION: Failure to obey a safety warning may result in property damage or personal injury to yourself or to others. Always follow the safety precautions to reduce the risk of fire, electric shock and personal injury.

NOTE: Advises you of information or instructions vital to the operation or maintenance of the equipment.

IMPORTANT

Servicing requires extreme care and knowledge of the system and should be performed only by a qualified service technician. For service we suggest you return the tool to your nearest Sears store or Sears Service Center for repair. Always use original factory replacement parts when servicing.

 **WARNING:** Do not attempt to operate this tool until you have read thoroughly and understand completely all instructions, safety rules, etc. contained in this manual. Failure to comply can result in accidents involving fire, electric shock, or serious personal injury. Save owner's manual and review frequently for continuing safe operation, and instructing others who may use this tool.

READ ALL INSTRUCTIONS

- **KNOW YOUR POWER TOOL.** Read the owner's manual carefully. Learn the saw's applications and limitations as well as the specific potential hazards related to this tool.
- **GUARD AGAINST ELECTRICAL SHOCK BY PREVENTING BODY CONTACT WITH GROUNDED SURFACES.** For example; pipes, radiators, ranges, refrigerator enclosures.
- **KEEP GUARDS IN PLACE** and in good working order.

- **REMOVE ADJUSTING KEYS AND WRENCHES.** Get in the habit of checking to see that hex keys and adjusting wrenches are removed from tool before turning on saw.
- **KEEP THE WORK AREA CLEAN.** Cluttered work areas and work benches invite accidents. **DO NOT** leave tools or pieces of wood on the saw while it is in operation.
- **DO NOT USE IN DANGEROUS ENVIRONMENTS.** Do not use power tools near gasoline or other flammable liquids, in damp or wet locations, or expose them to rain. Keep the work area well lit.
- **KEEP CHILDREN AND VISITORS AWAY.** All visitors should wear safety glasses and be kept a safe distance from work area. Do not let visitors contact tool or extension cord while operating.
- **MAKE WORKSHOP CHILD-PROOF** with padlocks and master switches, or by removing starter keys.
- **DO NOT FORCE THE TOOL.** It will do the job better and safer at the rate for which it was designed.
- **USE THE RIGHT TOOL.** Do not force the tool or attachment to do a job it was not designed for. Don't use it for a purpose not intended.

RULES FOR SAFE OPERATION (Continued)

- **USE THE PROPER EXTENSION CORD FOR CHARGER.** Make sure your extension cord is in good condition. When using an extension cord, be sure to use one heavy enough to carry the current your product will draw. An undersized cord will cause a drop in line voltage resulting in loss of power and overheating. A wire gage size (A.W.G.) of at least **16** is recommended for an extension cord 25 feet or less in length. If in doubt, use the next heavier gage. The smaller the gage number, the heavier the cord.
 - **INSPECT EXTENSION CORDS PERIODICALLY** and replace if damaged.
 - **DRESS PROPERLY.** Do not wear loose clothing, gloves, neckties, rings, bracelets, or other jewelry. They can get caught and draw you into moving parts. Rubber gloves and nonslip footwear are recommended when working outdoors. Also wear protective hair covering to contain long hair.
 - **ALWAYS WEAR SAFETY GLASSES WITH SIDE SHIELDS.** Everyday eyeglasses have only impact-resistant lenses; they are **NOT** safety glasses.
 - **PROTECT YOUR LUNGS.** Wear a face or dust mask if the cutting operation is dusty.
 - **PROTECT YOUR HEARING.** Wear hearing protection during extended periods of operation.
 - **SECURE WORK.** Use clamps or a vise to hold work when practical. It's safer than using your hand and it frees both hands to operate tool.
 - **DO NOT OVERREACH.** Keep proper footing and balance at all times.
 - **MAINTAIN TOOLS WITH CARE.** Keep tools sharp and clean for better and safer performance. Follow instructions for lubricating and changing accessories.
 - **DISCONNECT ALL TOOLS.** When not in use, before servicing, or when changing attachments, blades, bits, cutters, etc., all tools should be disconnected or battery pack removed.
 - **AVOID ACCIDENTAL STARTING.** Be sure **switch is in the locked or off position before inserting battery pack.** Carrying tools with your finger on the switch or inserting the battery pack into a tool with the switch on invites accidents.
 - **USE RECOMMENDED ACCESSORIES.** The use of improper accessories may cause risk of injury.
 - **NEVER STAND ON TOOL.** Serious injury could occur if the tool is tipped or if the blade is unintentionally contacted.
 - **CHECK DAMAGED PARTS.** Before further use of the tool, a guard or other part that is damaged should be carefully checked to determine that it will operate properly and perform its intended function. Check for alignment of moving parts, binding of moving parts, breakage of parts, mounting and any other conditions that may affect its operation. A guard or other part that is damaged must be properly repaired or replaced by a qualified service technician at a Sears store to avoid risk of personal injury.
 - **NEVER LEAVE TOOL RUNNING UNATTENDED. TURN THE POWER OFF.** Do not leave tool until it comes to a complete stop.
 - **FIRMLY CLAMP OR BOLT** your miter saw to a workbench or table at approximately hip height.
 - **USE ONLY CORRECT BLADES.** Do not use blades with incorrect size holes. Never use blade washers or blade bolts that are defective or incorrect. The maximum blade capacity of your saw is 8-1/4 in.
 - **KEEP BLADES CLEAN, SHARP AND WITH SUFFICIENT SET.** Sharp blades minimize stalling and kickback.
 - **DO NOT REMOVE THE SAW'S BLADE GUARDS.** Never operate the saw with any guard or cover removed. Make sure all guards are operating properly before each use.
 - **KEEP HANDS AWAY FROM CUTTING AREA.** Keep hands away from blades. Do not reach underneath work or around or under the blade while blade is rotating. Do not attempt to remove cut material when blade is moving.
-  **WARNING:** Blade coasts after turn off.
- **DO NOT ABUSE CORD.** Never yank cord to disconnect it from receptacle. Keep cord from heat, oil, and sharp edges.
 - **INSPECT CHARGER CORD PERIODICALLY** and if damaged, have repaired by a qualified service technician at a Sears store. Stay constantly aware of cord location and keep it well away from the rotating blade.
 - **USE OUTDOOR EXTENSION CORDS FOR CHARGER.** When tool is used outdoors, use only extension cords with approved ground connection that are intended for use outdoors and so marked.
 - **DO NOT USE TOOL IF SWITCH DOES NOT TURN IT ON AND OFF.** Have defective switches replaced by a qualified service technician at a Sears store.

RULES FOR SAFE OPERATION (Continued)

- **KEEP TOOL DRY, CLEAN, AND FREE FROM OIL AND GREASE.** Always use a clean cloth when cleaning. Never use brake fluids, gasoline, petroleum-based products, or any solvents to clean tool.
 - **ALWAYS SUPPORT LONG WORKPIECES** to minimize risk of blade pinching and kickback. Saw may slip, walk, or slide while cutting long or heavy boards.
 - **BEFORE MAKING A CUT, BE SURE ALL ADJUSTMENTS ARE SECURE.**
 - **AVOID CUTTING NAILS.** Inspect for and remove all nails from lumber before cutting.
 - **ALWAYS USE A CLAMP** to secure the workpiece when possible.
 - **NEVER TOUCH BLADE** or other moving parts during use.
 - **NEVER START A TOOL WHEN THE BLADE IS IN CONTACT WITH WORKPIECE.** Allow motor to come up to full speed before starting cut.
 - **MAKE SURE THE MITER TABLE AND SAW ARM (BEVEL FUNCTION) ARE LOCKED IN POSITION BEFORE OPERATING YOUR SAW.** Lock the miter table by securely tightening the miter lock handle. Lock the saw arm (bevel function) by securely tightening the bevel lock knob.
 - **NEVER USE A LENGTH STOP ON THE FREE SCRAP END OF A CLAMPED WORKPIECE.** NEVER hold onto or bind the free scrap end of the workpiece in any operation. If a work clamp and length stop are used together, they must both be installed on the same side of the saw table to prevent the saw from catching the loose end and kicking up.
 - **NEVER** cut more than one piece at a time. **DO NOT STACK** more than one workpiece on the saw table at a time.
 - **NEVER PERFORM ANY OPERATION "FREE-HAND".** Always place the workpiece to be cut on the miter table and position it firmly against and parallel to the fence as a backstop. Always use the fence.
 - **NEVER** hand hold a workpiece that is too small to be clamped. Keep hands clear of the no hands zone.
 - **NEVER** reach behind, under, or within three inches of the blade and its cutting path with your hands and fingers for any reason.
 - **NEVER** reach to pick up a workpiece, a piece of scrap, or anything else that is in or near the cutting path of the blade.
 - **AVOID AWKWARD OPERATIONS AND HAND POSITIONS** where a sudden slip could cause your hand to move into the blade. **ALWAYS** make sure you have good balance. **NEVER** operate your miter saw on the floor or in a crouched position.
 - **NEVER** stand or have any part of your body in line with the path of the saw blade.
 - **ALWAYS** release the power switch and allow the saw blade to stop rotating before raising it out of the workpiece.
 - **DO NOT TURN THE MOTOR SWITCH ON AND OFF RAPIDLY.** This could cause the saw blade to loosen and could create a hazard. Should this ever occur, stand clear and allow the saw blade to come to a complete stop. Disconnect your saw from the power supply and securely retighten the blade bolt.
 - **REPLACEMENT PARTS.** All repairs, whether electrical or mechanical, should be made by qualified service technician at a Sears store.
-  **WARNING:** When servicing use only identical Craftsman replacement parts. Use of any other parts may create a hazard or cause product damage.
- **NEVER USE IN AN EXPLOSIVE ATMOSPHERE.** Normal sparking of the motor could ignite fumes.
 - **NEVER** leave the miter saw unattended while connected to a power source.
 - **POLARIZED PLUGS.** To reduce the risk of electric shock, this charger has a polarized plug (one blade is wider than the other). This charger plug will fit in a polarized outlet only one way. If the plug does not fit fully in the outlet, reverse the plug. If it still does not fit, contact a qualified electrician to install the proper outlet. Do not change the plug in any way.
 - **IF ANY PART OF THIS MITER SAW IS MISSING** or should break, bend, or fail in any way, or should any electrical component fail to perform properly, shut off the power switch, remove the miter saw plug from the power source and have damaged, missing, or failed parts replaced before resuming operation.

RULES FOR SAFE OPERATION (Continued)

- **DO NOT OPERATE THIS TOOL WHILE UNDER THE INFLUENCE OF DRUGS, ALCOHOL, OR ANY MEDICATION.**
- **ALWAYS STAY ALERT!** Do not allow familiarity (gained from frequent use of your saw) to cause a careless mistake. **ALWAYS REMEMBER** that a careless fraction of a second is sufficient to inflict severe injury.
- **STAY ALERT AND EXERCISE CONTROL.** Watch what you are doing and use common sense. **Do not operate tool when you are tired. Do not rush.**
- **MAKE SURE THE WORK AREA HAS AMPLE LIGHTING** to see the work and that no obstructions will interfere with safe operation **BEFORE** performing any work using your saw.
- **ALWAYS TURN OFF SAW** before disconnecting it, to avoid accidental starting when reconnecting to power supply.

IMPORTANT SAFETY RULES FOR BATTERY TOOLS

- Battery tools do not have to be plugged into an electrical outlet; therefore, they are always in operating condition. Be aware of possible hazards when not using your battery tool or when changing accessories.
- **Remove battery pack from tool or make sure the switch is in the lock-off position before making any adjustments, changing accessories, or storing the tool.** Such preventive safety measures reduce the risk of starting the tool accidentally.
- **When battery pack is not in use, keep it away from other metal objects like: paper clips, coins, keys, nails, screws, or other small metal objects that can make a connection from one terminal to another.** Shorting the battery terminals together may cause sparks, burns, or a fire.
- **Use battery operated tool only with specifically designated battery pack.** Use of any other batteries may create a risk of fire. Use only the battery pack listed.
- **USE ONLY THE CHARGER PROVIDED WITH YOUR BATTERY TOOL.** Do not substitute any other charger. Use of another charger could cause batteries to explode causing possible serious injury.
- **DO NOT PLACE BATTERY TOOLS OR THEIR BATTERIES NEAR FIRE OR HEAT.** They may explode.
- **DO NOT CHARGE BATTERY TOOL IN A DAMP OR WET LOCATION.**

- Your battery tool should be charged in a location where the temperature is more than 50°F but less than 100°F.
- Under extreme usage or temperature conditions, battery leakage may occur. If liquid comes in contact with your skin, wash immediately with soap and water, then neutralize with lemon juice or vinegar. If liquid gets in your eyes, flush them with clean water for at least 10 minutes, then seek immediate medical attention.
- If carrying your battery tool at your side, make sure it is not running and your finger is not on the switch. Avoid accidental starting.
- **WHEN SERVICING USE ONLY IDENTICAL CRAFTSMAN REPLACEMENT PARTS.**

IMPORTANT SAFETY INSTRUCTIONS FOR CHARGER

- **SAVE THESE INSTRUCTIONS.** This manual contains important safety and operating instructions for charger item number 9-11040 (981399-001).
 - Before using charger, read all instructions and cautionary markings in this manual, on charger, and product using charger.
- ⚠ WARNING:** To reduce risk of injury, charge only nickel-cadmium type rechargeable batteries. Other types of batteries may burst causing personal injury and damage.
- Do not expose charger to rain or snow.
 - Use of an attachment not recommended or sold by the charger manufacturer may result in a risk of fire, electric shock, or injury to persons.
 - To reduce risk of damage to charger and cord, pull by charger plug rather than cord when disconnecting charger.
 - Make sure cord is located so that it will not be stepped on, tripped over, or otherwise subjected to damage or stress.
 - An extension cord should not be used unless absolutely necessary. Use of improper extension cord could result in a risk of fire and electric shock. If extension cord must be used, make sure:
 - a. That pins on plug of extension cord are the same number, size and shape as those of plug on charger.
 - b. That extension cord is properly wired and in good electrical condition; and
 - c. That wire size is large enough for AC ampere rating of charger as specified below:

Cord Length (Feet)	25'	50'	100'
Cord Size (AWG)	16	16	16

Note: AWG = American Wire Gage

RULES FOR SAFE OPERATION (Continued)

- **DO NOT OPERATE CHARGER WITH A DAMAGED CORD OR PLUG.** If damaged, have replaced immediately by a qualified serviceman.
- Do not operate charger if it has received a sharp blow, been dropped, or otherwise damaged in any way; take it to a qualified serviceman.
- Do not disassemble charger; take it to a qualified serviceman when service or repair is required. Incorrect reassembly may result in a risk of electric shock or fire.
- To reduce risk of electric shock, unplug charger from outlet before attempting any maintenance or cleaning. Turning off controls will not reduce this risk.
- Do not use charger outdoors.
- Disconnect charger from power supply when not in use.
- **SAVE THESE INSTRUCTIONS.** Refer to them frequently and use them to instruct others who may use this tool. If you loan someone this tool, loan them these instructions also.

⚠ WARNING: Some dust created by power sanding, sawing, grinding, drilling, and other construction activities contains chemicals known to cause cancer, birth defects or other reproductive harm. Some examples of these chemicals are:

- lead from lead-based paints,
- crystalline silica from bricks and cement and other masonry products, and
- arsenic and chromium from chemically-treated lumber.

Your risk from these exposures varies, depending on how often you do this type of work. To reduce your exposure to these chemicals: work in a well ventilated area, and work with approved safety equipment, such as those dust masks that are specially designed to filter out microscopic particles.

SAVE THESE INSTRUCTIONS

GLOSSARY OF TERMS FOR WOODWORKING

Arbor

The shaft on which a blade or cutting tool is mounted.

Bevel Cut

A cutting operation made with the blade at any angle other than 90° to the miter table.

Crosscut

A cutting or shaping operation made across the grain of the workpiece.

Compound Miter Cut

A compound miter cut is a cut made using a miter angle and a bevel angle at the same time.

Freehand

Performing a cut without using a fence, miter gage, fixture, work clamp, or other proper device to keep the workpiece from twisting or moving during the cut.

Gum

A sticky, sap based residue from wood products.

Miter Cut

A cutting operation made with the blade at any angle other than 90° to the fence.

No Hands Zone

The area between the marked lines on the left and right side of the miter table base. This zone is identified by no hands zone labels placed inside the marked lines on the miter table base.

Resin

A sticky, sap based substance.

Revolutions Per Minute (RPM)

The number of turns completed by a spinning object in one minute.

Saw Blade Path

The area over, under, behind, or in front of the blade. As it applies to the workpiece, that area which will be, or has been, cut by the blade.

Set

The distance that the tip of the saw blade tooth is bent (or set) outward from the face of the blade.

Throat Plate

A plastic throat plate inserted in the miter table that allows for blade clearance. This provides for a zero clearance kerf that minimizes workpiece tear-out.

Throw-Back

Throwing of a workpiece in a manner similar to a kickback. Usually associated with a cause other than the kerf closing, such as a workpiece not being against the fence, being dropped into the blade, or being placed inadvertently in contact with the blade.

Through Sawing

Any cutting operation where the blade extends completely through the thickness of the workpiece.

Workpiece

The item on which the cutting operation is being done. The surfaces of a workpiece are commonly referred to as faces, ends, and edges.

PRODUCT SPECIFICATIONS

Blade Diameter	8-1/4 in.	Cutting Capacity with Miter at 0°/Bevel 0°:
Blade Arbor	5/8 in.	5-1/2 in. W x 2-1/16 in. T
No Load Speed	2000 RPM	Maximum Cutting Capacity with Miter at 45°/Bevel 0°:
Charger Rating	120 Volts, 60 Hz-AC Only	3-3/4 in. W x 2-1/16 in. T
Charger Rate	1 Hour	Maximum Cutting Capacity with Miter at 0°/Bevel 45°:
Motor	18 Volt DC	5-1/2 in. W x 1-1/2 in. T
Net Weight	35 lbs.	Maximum Cutting Capacity with Miter at 45°/Bevel 45°:
Blade Type	Carbide Tipped (Thin Kerf)	3-3/4 in. W x 1-1/2 in. T

UNPACKING

Your Compound Miter Saw has been shipped completely assembled except for the battery pack, blade, dust guide, and dust bag.

⚠ WARNING: If any parts are missing, do not operate this tool until the missing parts are replaced. Failure to do so could result in possible serious personal injury.

- Remove all loose parts from the carton. Separate and check with the list of loose parts. *See Figure 2.*
- Remove the packing materials from around your saw.
- Carefully lift saw from the carton and place it on a level work surface. Although small, this saw is heavy. To avoid back injury, get help when needed.

- Do not discard the packing materials until you have carefully inspected the saw, identified all loose parts, and satisfactorily operated your new saw.
- Your saw has been shipped with the saw arm locked in the down position. To release saw arm, push down on top of saw arm and pull out the lock pin. *See Figure 9.*
- Lift the saw arm by the handle. Hand pressure should remain on the saw arm to prevent sudden rise upon release of the lock pin.
- Examine all parts to make sure no breakage or damage has occurred during shipping.

If any parts are damaged or missing, do not attempt to turn the switch on until the damaged or missing parts are obtained and are installed correctly.

LABELS

The following labels are on the miter saw with locations indicated.

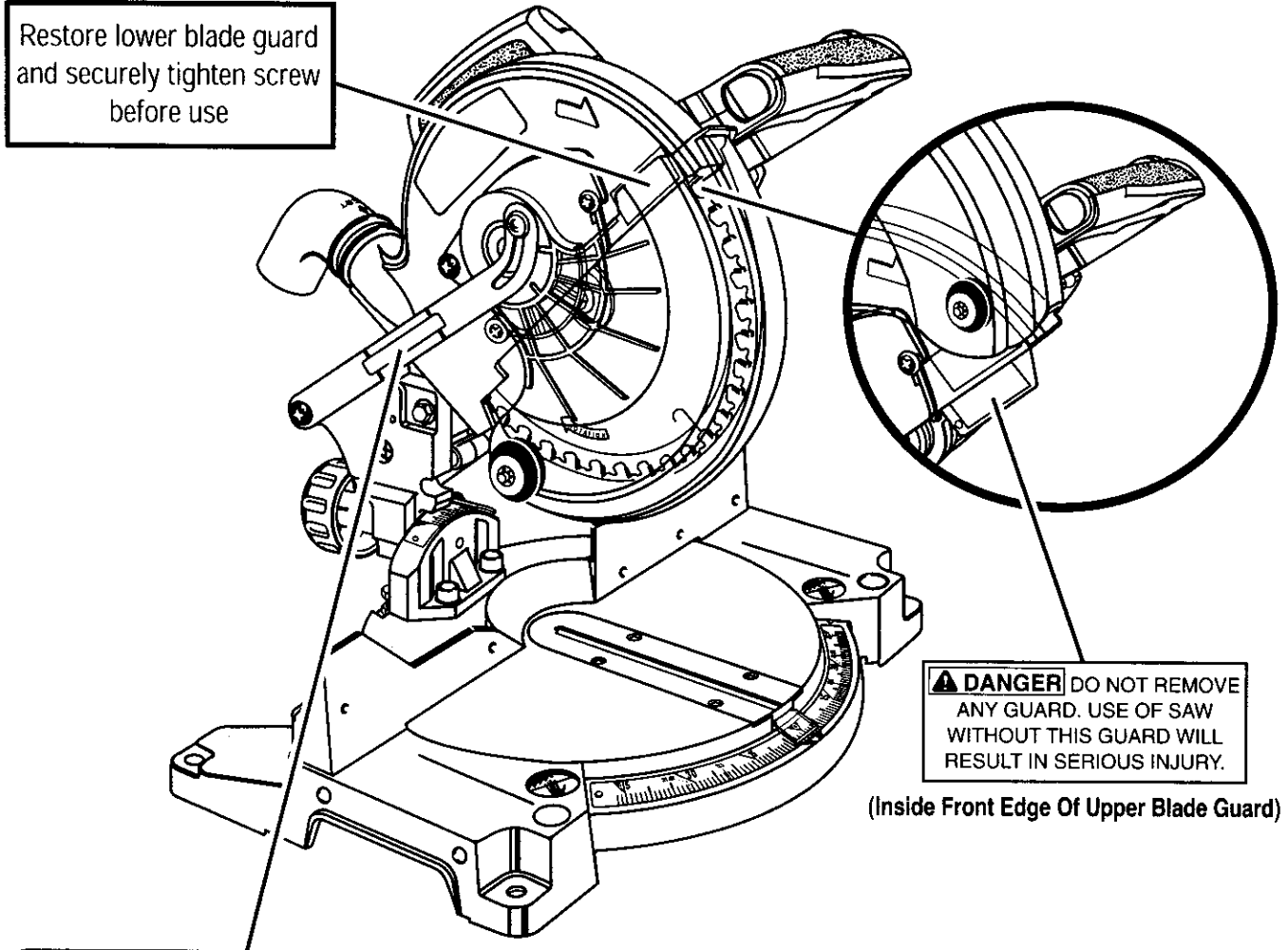

Lift For Blade Change. See Owner's Manual.

 STATIONARY TOOL	8 1/4 inch Miter Saw 2,000 RPM 18 VOLT DC	MODEL 315.212180 MADE IN CHINA SEARS, ROEBUCK AND CO. MODEL NO. 315. 110340
	USE ONLY WITH BATTERY PACK MODEL NO. 315. 110340	
WARNING USE ONLY IDENTICAL CRAFTSMAN REPLACEMENT PARTS.		
Customer Help Line 1-800-932-3188		

WARNING / ADVERTENCIA
<ul style="list-style-type: none"> • For your safety, read owners manual before operating miter saw. • Wear eye protection. • Keep hands out of path of saw blade. • Do not operate saw without guards in place. • Do not perform any operation freehand. • Never reach around the saw blade. • Turn off tool and wait for saw blade to stop before moving workpiece or changing settings. • Remove the battery from the saw before changing blade or servicing. • Do not expose to rain or use in damp places. • Para su seguridad, lea el manual del usuario antes de hacer funcionar la sierra ingletadora.

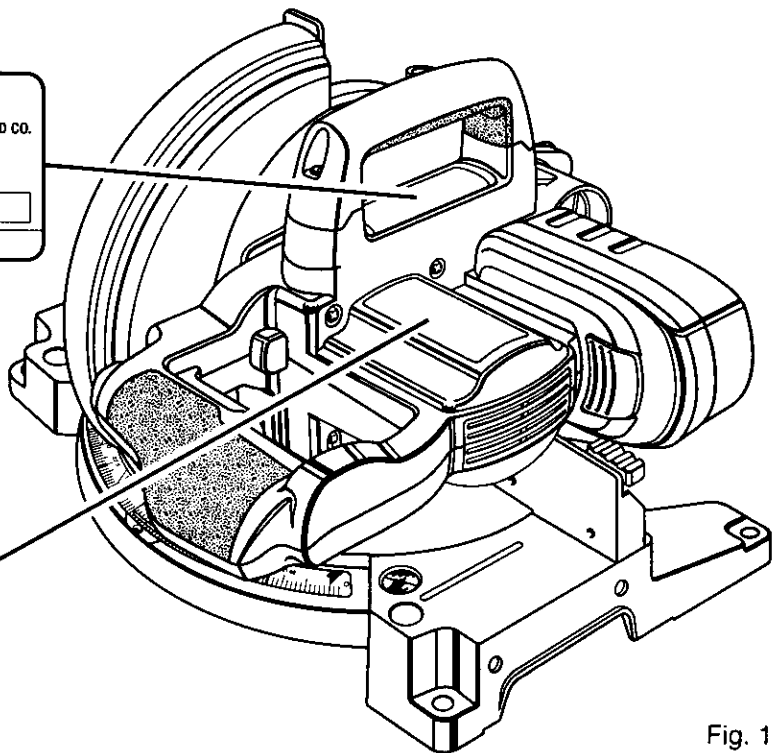

Fig. 1

LOOSE PARTS LIST

The following items are included with your Compound Miter Saw:

- Saw Blade - 8-1/4 in.
- Dust Guide
- Dust Bag
- Blade Wrench
- 5 mm Hex Key
- 6 mm Hex Key
- Owner's Manual

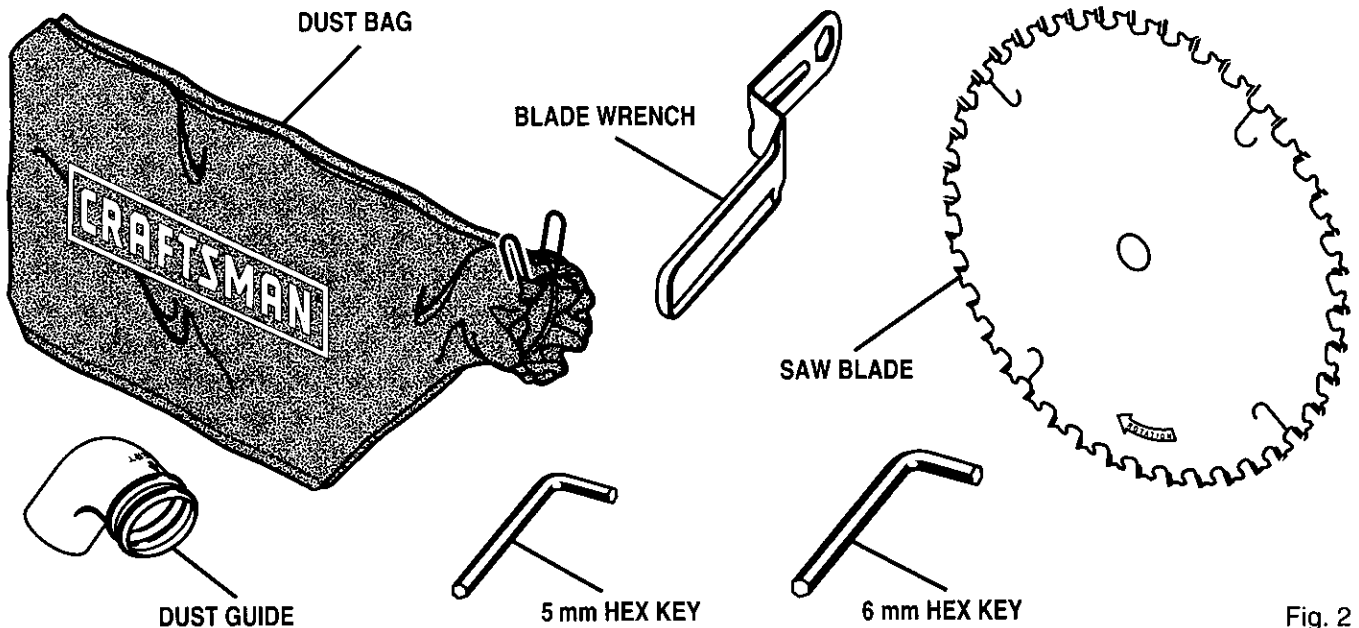

Fig. 2

⚠ WARNING: The use of attachments or accessories not listed might be hazardous and could cause serious personal injury.

TOOLS NEEDED

The following tools (not included) are needed for checking adjustments of your saw or for installing the blade:

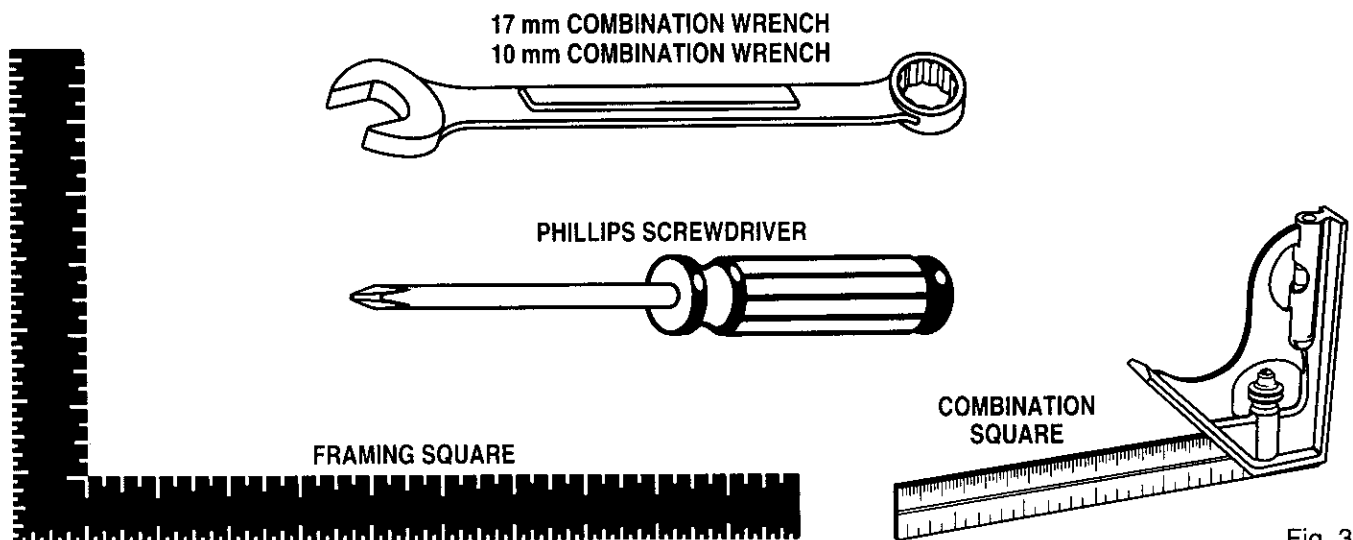

Fig. 3

BATTERY PACK AND CHARGING INFORMATION

BATTERY PACK

The battery pack for your saw is shipped in a low charge condition to prevent possible problems. Therefore, you should charge it prior to use.

⚠ WARNING: Always remove battery pack from your saw when you are assembling parts, making adjustments, assembling or removing blades, cleaning, or when not in use. Removing battery pack from your saw will prevent accidental starting that could cause serious personal injury.

CHARGING BATTERY PACK

As previously mentioned, the battery pack for this tool has been shipped in a low charge condition. Therefore, you should charge it until light on front of charger changes from red to green.

Note: Batteries will not reach full charge the first time they are charged. Allow several cycles (cutting followed by recharging) for them to become fully charged.

TO CHARGE

- Charge battery pack only with the charger provided.
- **Make sure power supply is normal household voltage, 120 volts, 60 Hz, AC only.**
- Connect charger to power supply.
- Attach battery pack to charger by aligning raised ribs on battery pack with grooves in charger, then slide battery back onto charger. *See Figure 4.*

- Red light should turn on. Red light indicates fast charging mode.
If red light is flashing, this indicates battery pack is deeply discharged or hot.
If battery pack is hot, red light should become steady after battery pack has cooled down.
If battery pack is deeply discharged, red light should become steady after voltage has increased, normally within 60 minutes.
If after one hour red light is still flashing, this indicates a defective battery pack and should be replaced.
Green light on indicates battery pack is fully charged and slow charging to maintain battery pack.
Yellow light on and red light flashing indicates defective battery pack. Return battery pack to your nearest Sears Repair Center for checking or replacing.
- When your battery pack becomes fully charged, the red light will turn **OFF** and the green light will turn **ON**.
- After normal usage, 1 hour of charging time is required to be fully charged. A minimum charge time of 1-1/2 hours is required to recharge a completely discharged tool.
- The battery pack will become slightly warm to the touch while charging. This is normal and does not indicate a problem.
- **Do not** place charger in an area of extreme heat or cold. It will work best at normal room temperature.
- When the batteries become fully charged, unplug your charger from power supply and remove the battery pack.

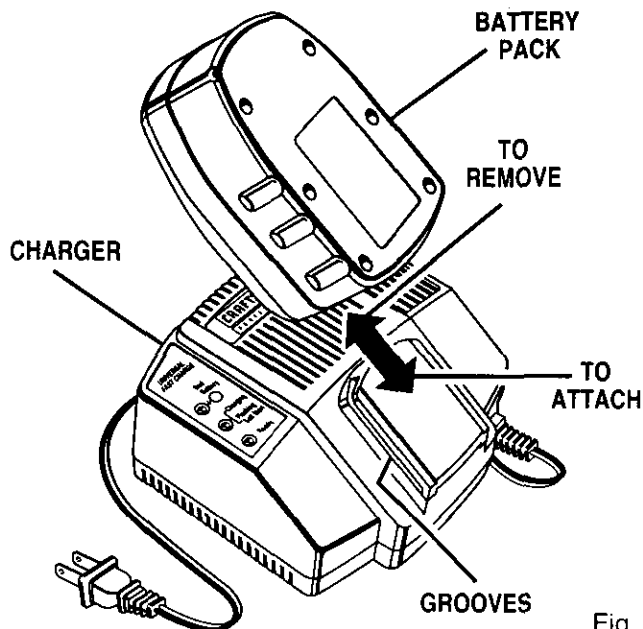

Fig. 4

FEATURES

LED FUNCTION OF CHARGER

See Figures 5 & 6.

LED WILL BE LIGHTED TO INDICATE STATUS OF CHARGER AND BATTERY PACK:

- Red LED Lighted = Fast Charging Mode.
- Green LED Lighted = Fully Charged And Slow Charging To Maintain Battery Pack.
- Red LED Flashing = Hot Or Deeply Discharged Battery Pack. Also Defective Battery Pack After 1 Hour.
- Yellow LED Lighted and Red LED Flashing = Defective Battery Pack.

YELLOW LIGHT "ON" AND RED LIGHT FLASHING INDICATES DEFECTIVE BATTERY PACK

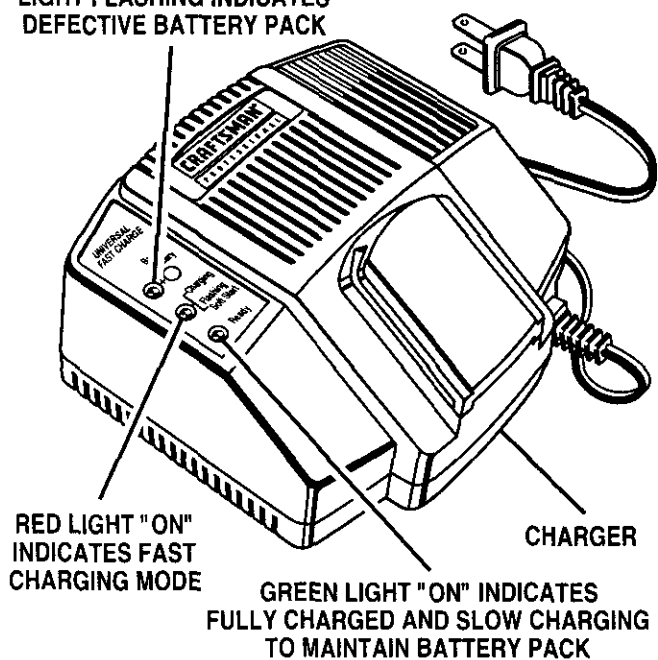

Fig. 5

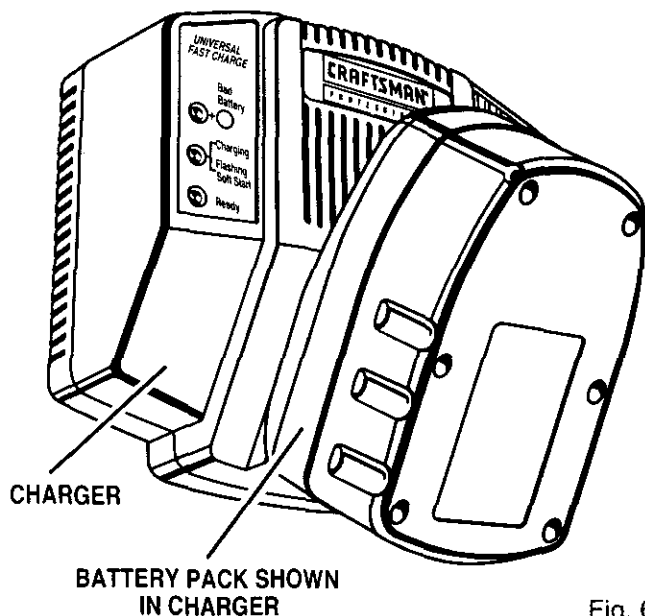

Fig. 6

IMPORTANT INFORMATION FOR RECHARGING HOT BATTERIES

Under extreme continuous use, the batteries in your battery pack will become hot. You should let a hot battery pack cool down for approximately 1 hour before attempting to recharge. When the battery pack becomes discharged and is hot, this will cause the red light on your battery charger to flash. When battery pack cools down, red light will glow continuously indicating fast charging mode, 1 hour charge time. Once the battery pack cools down, it will recharge battery pack in fast charging mode as normal.

Note: This situation only occurs when extreme continuous use of your saw causes the batteries to become hot. **It does not occur under normal circumstances.** Refer to "CHARGING BATTERY PACK" for normal recharging of batteries. If the charger does not charge your battery pack under normal circumstances, return **both** the battery pack and charger to your nearest Sears repair center for electrical check.

MOUNTING CHARGER

See Figure 7.

Your charger has a "key hole" hanging feature for convenient, space saving storage. Screws should be installed so that center distances are 4-1/8 inches apart.

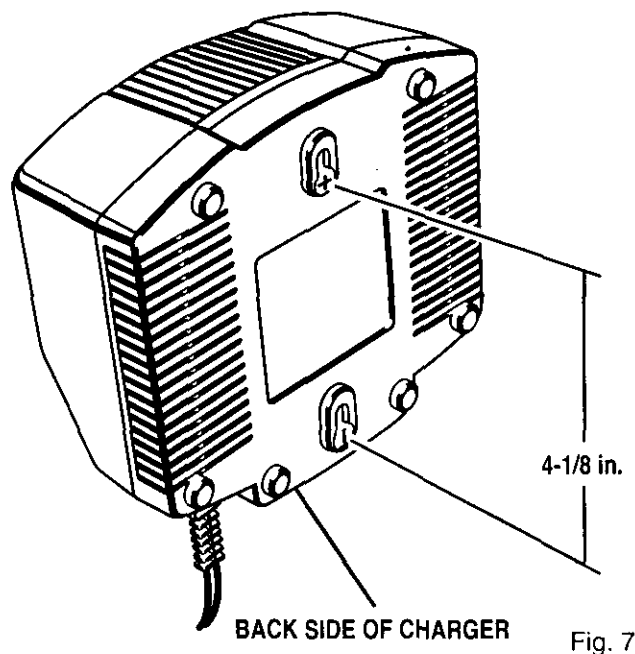

Fig. 7

FEATURES

KNOW YOUR COMPOUND MITER SAW

See Figure 8.

Before attempting to use your saw, familiarize yourself with all operating features and safety requirements.

⚠ WARNING: Do not allow familiarity with your saw to make you careless. Remember that a careless fraction of a second is sufficient to inflict severe injury.

8-1/4 in. BLADE

A 8-1/4 in. saw blade is included with your compound miter saw. It will cut materials up to 2-1/16 in. thick or 5-1/2 in. wide, depending upon the thickness of the material and the setting at which the cut is being made.

CUTTING CAPACITIES

When the miter angle (miter table) is set at 0° and the bevel angle is set at 0°:

Your saw will cut materials up to a maximum of 5-1/2 in. wide x 2-1/16 in. thick.

When the miter angle (miter table) is set at 45° and the bevel angle is set at 0°:

Your saw will cut materials up to a maximum of 3-3/4 in. wide x 2-1/16 in. thick.

When the miter angle (miter table) is set at 0° and the bevel angle is set at 45°:

Your saw will cut materials up to a maximum of 5-1/2 in. wide x 1-1/2 in. thick.

When the miter angle (miter table) is set at 45° and the bevel angle is set at 45°:

Your saw will cut materials up to a maximum of 3-3/4 in. wide x 1-1/2 in. thick.

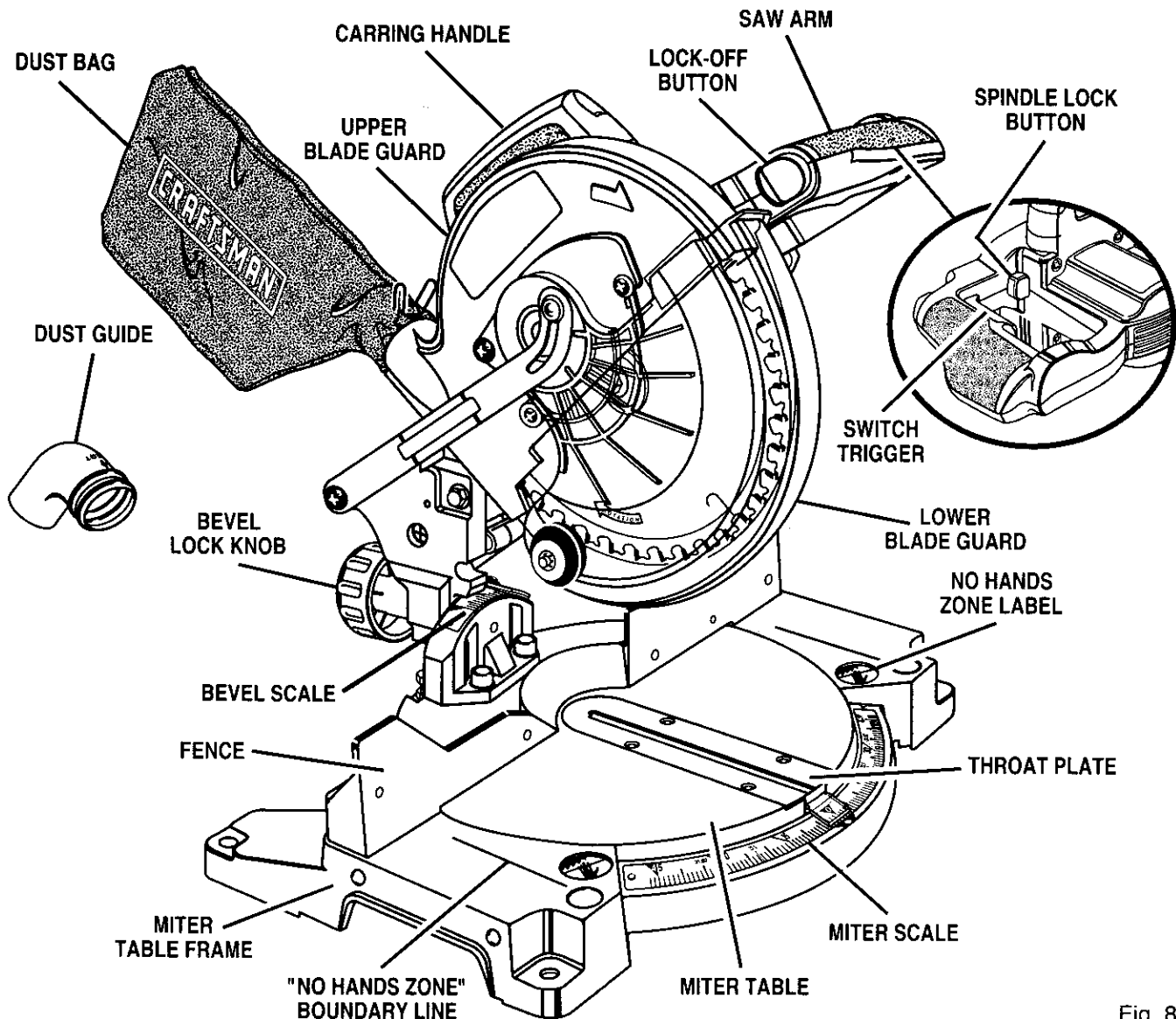

Fig. 8

FEATURES

CARRYING HANDLE

See Figure 9.

For convenience when carrying or transporting your miter saw from one place to another, a carrying handle has been provided on top of the saw arm as shown in figure 9. To transport saw, remove battery pack, then lower the saw arm and lock it in the down position. Lock saw arm by depressing the lock pin.

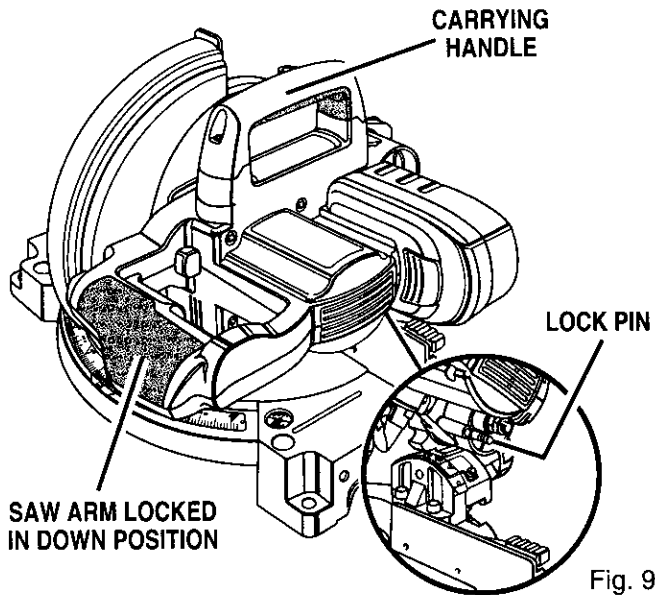

Fig. 9

MITER TABLE CLAMP

See Figure 10.

The miter table clamp securely locks your saw at desired miter angles.

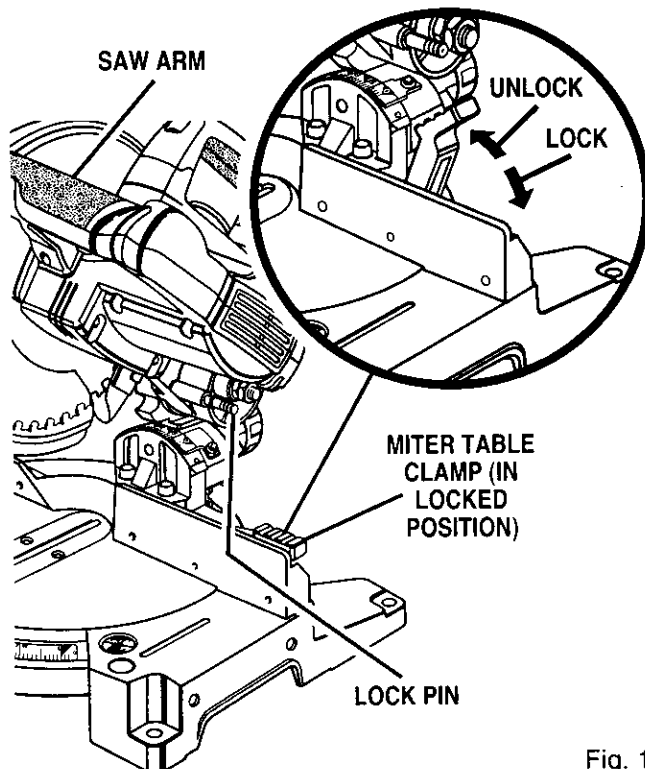

Fig. 10

SPINDLE LOCK BUTTON

See Figure 11.

A spindle lock button has been provided for locking the spindle which keeps the blade in your saw from rotating. Depress and hold the spindle lock button while installing, changing, or removing the blade only.

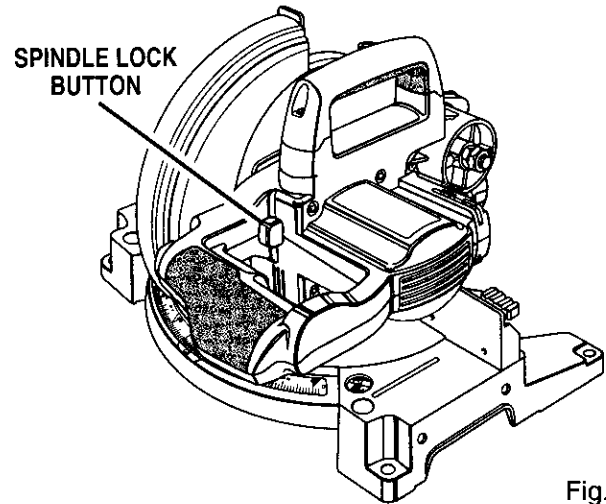

Fig. 11

LOCK-OFF BUTTON

See Figure 12.

The switch trigger is equipped with a lock-off button to reduce the possibility of accidental starting.

To release lock-off feature:

- Depress lock-off button (1).
- While holding lock-off button pushed in, (2) depress switch trigger.
- Release lock-off button (3).

Note: The spring loaded button will spring back into the lock-off position when the switch trigger is released.

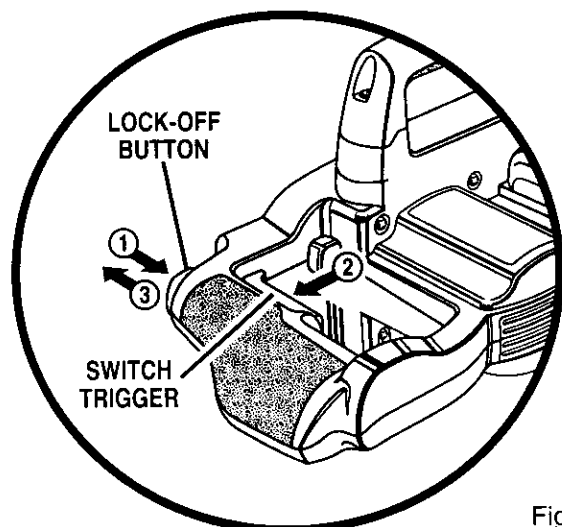

Fig. 12

FEATURES

TRIGGER LOCK

See Figure 13.

To prevent unauthorized use of your compound miter saw, we suggest that you remove battery pack and lock the switch in the off position. To lock the switch, install a padlock through the hole in the switch trigger. A lock with a shackle up to $13/64$ in. diameter may be used. When the lock is installed and locked, the switch is inoperable. Store the padlock key in another location.

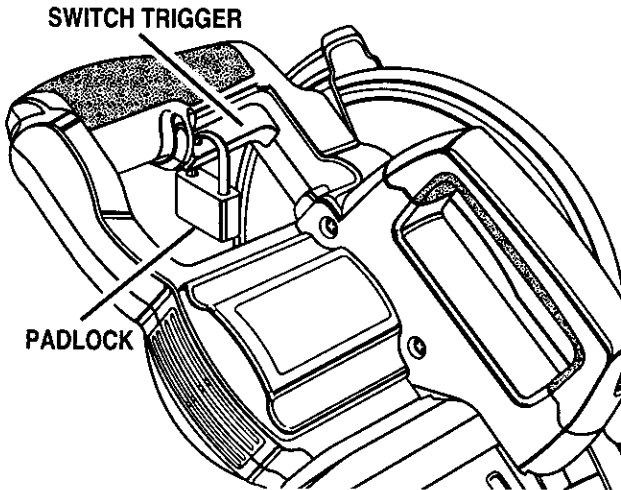

Fig. 13

POSITIVE STOPS ON MITER TABLE

Positive stops have been provided at 0° , $22\text{-}1/2^\circ$ and 45° . The $22\text{-}1/2^\circ$ and 45° positive stops have been provided on both the left and right side of the miter table.

BEVEL LOCK KNOB

The bevel lock knob securely locks your compound miter saw at desired bevel angles. Positive stop adjustment screws have been provided on each side of the saw arm. These adjustment screws are for making fine adjustments at 0° and 45° . See pages 22 and 23.

ELECTRIC BRAKE

An electric brake has been provided to quickly stop blade rotation after the switch is released.

FENCE

The fence on your compound miter saw has been provided to hold your workpiece securely against when making all cuts.

SELF-RETRACTING LOWER BLADE GUARD

The lower blade guard is made of shock-resistant, see-through plastic that provides protection from each side of the blade. It retracts over the upper blade guard as the saw is lowered into the workpiece.

MOUNTING HOLES

See Figure 14.

Your compound miter saw should be permanently mounted to a firm supporting surface such as workbench. Four $3/8$ in. bolt holes have been provided in the saw base for this purpose. Each of the four mounting holes should be bolted securely using $3/8$ in. machine bolts, lock washers, and hex nuts (not included). Bolts should be of sufficient length to accommodate the saw base, lock washers, hex nuts, and the thickness of the workbench.

Tighten all four bolts securely.

The hole pattern for an 18-5/8 in. x 24 in. workbench is shown in Figure 14. Carefully check the workbench after mounting to make sure that no movement can occur during use. If any tipping, sliding, or walking is noted, secure the workbench to the floor before operating.

WARNING: Always make sure your compound miter saw is securely mounted to a workbench or an approved workstand. Failure to do so could result in an accident resulting in possible serious personal injury.

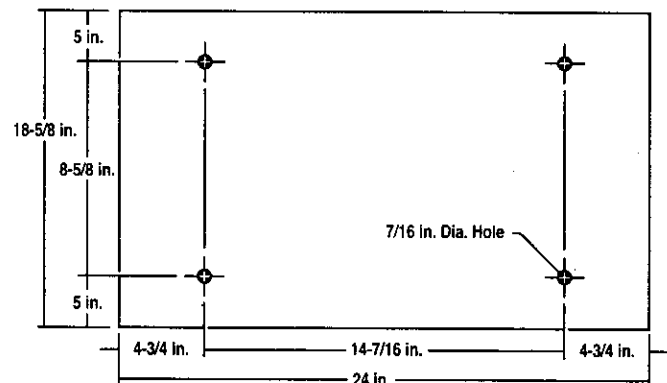

Fig. 14

WARNING: The operation of any saw can result in foreign objects being thrown into your eyes, which can result in severe eye damage. Before starting power tool operation, always wear safety goggles or safety glasses with side shields and a full face shield when needed. We recommend wide vision safety mask for use over eyeglasses or standard safety glasses with side shields.

WARNING: Do not attempt to modify this tool or create accessories not recommended for use with this tool. Any such alteration or modification is misuse and could result in a hazardous condition leading to possible serious personal injury.

ADJUSTMENTS

⚠ WARNING: To prevent accidental starting that could cause possible serious personal injury, assemble all parts to your saw before attaching battery pack. Battery pack should never be attached to saw when you are assembling parts, making adjustments, installing or removing blades, or when not in use.

As mentioned previously your saw has been factory assembled and adjusted. The dust guide, dust bag and blade are the only parts that have to be installed.

DUST GUIDE

See Figure 15.

■ Remove battery pack from saw.

⚠ WARNING: Failure to remove battery pack from your saw could result in accidental starting causing possible serious personal injury.

To install the dust guide, place the end marked **INSERT** over the exhaust port in the upper blade guard. Turn the guide so that the open end is facing down or toward the rear of the saw.

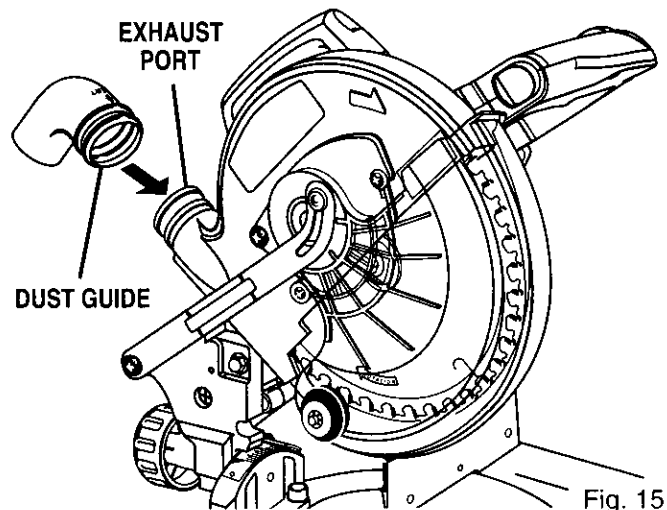

DUST BAG

See Figure 16.

■ Remove battery pack from saw.

⚠ WARNING: Failure to remove battery pack from your saw could result in accidental starting causing possible serious personal injury.

Dust bag (Item No. 9-23466) is packed with your saw. It fits over the exhaust port on the upper blade guard. To install it, remove the dust guide from the exhaust port. Then, squeeze the two metal clips to open the mouth of the bag and slide it on the exhaust port. Release the clips. The metal ring in the bag should lock in between the grooves on the exhaust port. For more efficient operation, empty dust bag when no more than half full. This will permit better air flow through the bag.

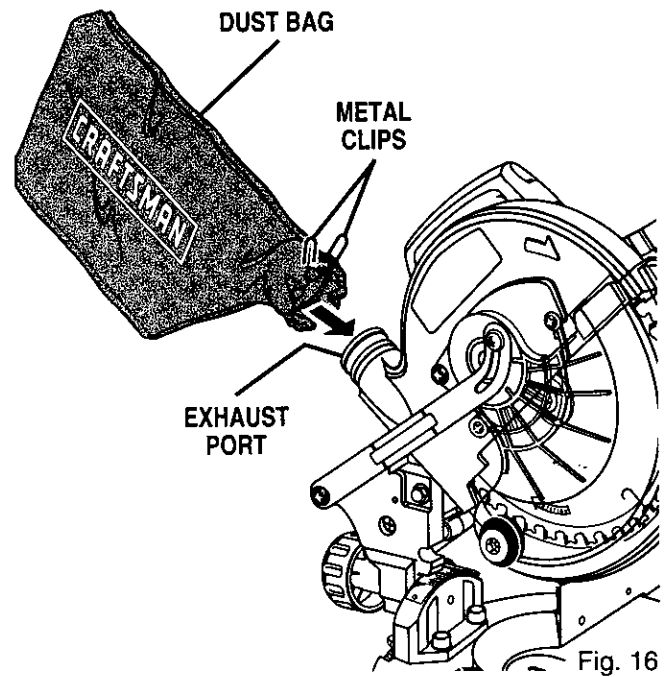

ADJUSTMENTS

TO INSTALL BLADE

See Figures 17, 18, 19 and 20.

⚠ DANGER: A 8-1/4 in. blade is the maximum blade capacity of your saw. Never use a blade that is too thick to allow outer blade washer to engage with the flats on the spindle. Larger blades will come in contact with the blade guards, while thicker blades will prevent the blade screw from securing the blade on the spindle. Either of these situations will result in a serious accident and can cause serious personal injury.

■ Remove battery pack from saw.

⚠ WARNING: Failure to remove battery pack from your saw could result in accidental starting causing possible serious personal injury.

■ Push down on the saw arm and pull out the lock pin to release saw arm. Raise saw arm to its full raised position. Be cautious, saw arm is spring loaded to raise.

■ Loosen the phillips screw on the blade bolt cover until blade bolt cover can be raised. See Figure 17.

■ Gently raise the lower blade guard bracket, releasing lower blade guard from notch so that lower blade guard and blade bolt cover can be rotated up and back to expose the blade bolt. See Figure 18.

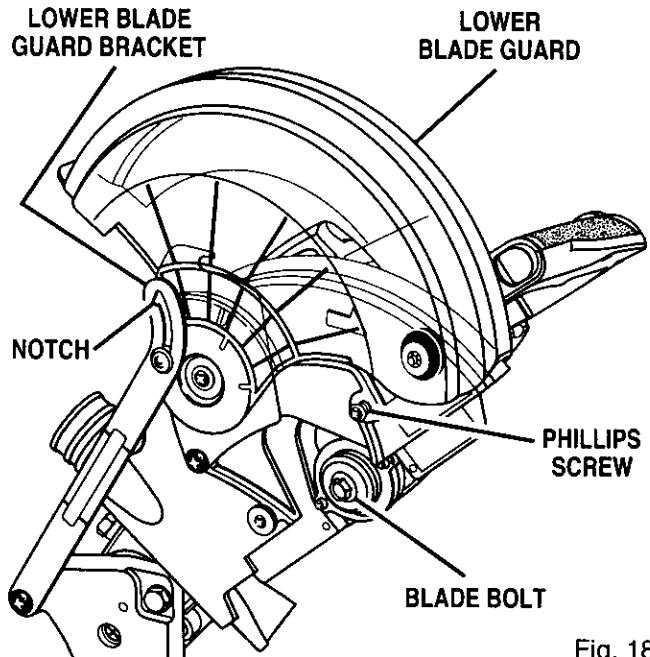

Fig. 18

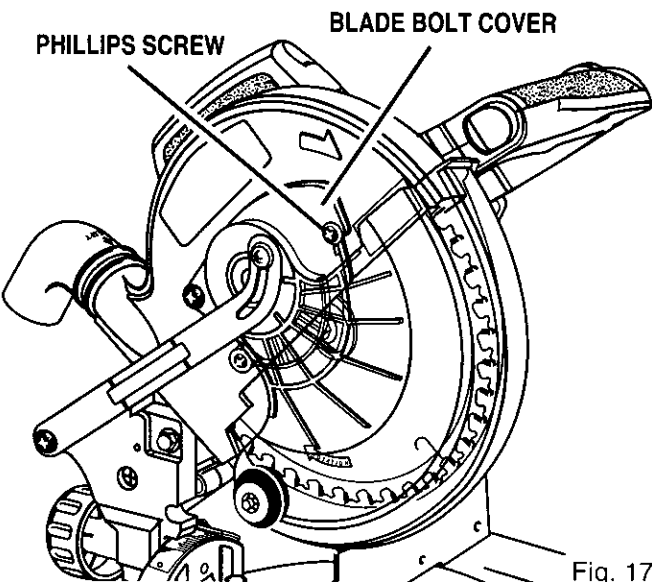

Fig. 17

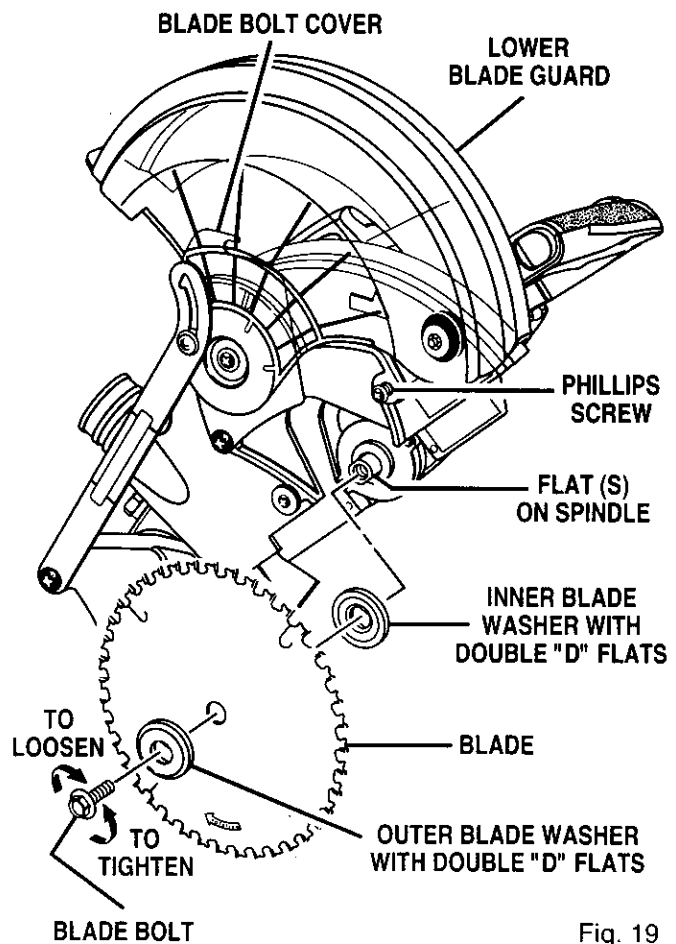

Fig. 19

ADJUSTMENTS

- Depress the spindle lock button and rotate the blade bolt until the spindle locks. *See Figure 20.*
- Using the blade wrench provided, loosen and remove the blade bolt.

Note: The blade bolt has left hand threads. Turn blade bolt clockwise to loosen.

- Remove outer blade washer. **Do not** remove inner blade washer.
- Wipe a drop of oil onto inner blade washer and outer blade washer where they contact the blade.

WARNING: If inner blade washer has been removed, replace it before placing blade on spindle. Failure to do so could cause an accident since blade will not tighten properly.

- Fit saw blade inside lower blade guard and onto spindle. The blade teeth point downward at the front of saw as shown in figure 19.

CAUTION: Always install the blade with the blade teeth and the arrow printed on the side of the blade pointing down at the front of the saw. The direction of blade rotation is also stamped with an arrow on the upper blade guard.

- Replace outer blade washer. The double "D" flats on the blade washers align with the flats on the spindle.
- Depress spindle lock button and replace blade bolt.
Note: The blade bolt has left hand threads. Turn blade bolt counterclockwise to tighten.
- Using the blade wrench provided, tighten blade bolt securely.
- Remove the blade wrench and store it in a safe place for future use.
- Replace the lower blade guard and blade bolt cover.
- Retighten phillips screw securing blade bolt cover. Tighten screw securely. *See Figure 19.*

WARNING: To prevent damage to the spindle lock, always allow motor to come to a complete stop before engaging spindle lock. Make sure the spindle lock button is not engaged before attaching battery pack.

TO REMOVE BLADE

See Figures 17, 18, 19, and 20.

- Remove battery pack from saw.

WARNING: Failure to remove battery pack from your saw could result in accidental starting causing possible serious personal injury.

- Loosen the phillips screw on the blade bolt cover until blade bolt cover can be raised. *See Figures 17, 18, and 19.*
- Gently raise the lower blade guard bracket, releasing lower blade guard from notch so that lower blade guard and blade bolt cover can be rotated up and back to expose the blade bolt. *See Figure 18.*
- Depress the spindle lock button and rotate the blade bolt until the spindle locks. *See Figure 20.*
- Using the blade wrench provided, loosen and remove the blade bolt.
Note: The blade bolt has left hand threads. Turn blade bolt clockwise to loosen.
- Remove outer blade washer. The blade can now be removed.

Your compound miter saw has been adjusted at the factory for making very accurate cuts. However, some of the components might have been bumped out of alignment during shipping. Also, over a period of time, readjustment will probably become necessary due to wear. After unpacking your saw, check the following adjustments before you begin using saw. Make any readjustments that are necessary and periodically check the parts alignment to make sure that your saw is cutting accurately.

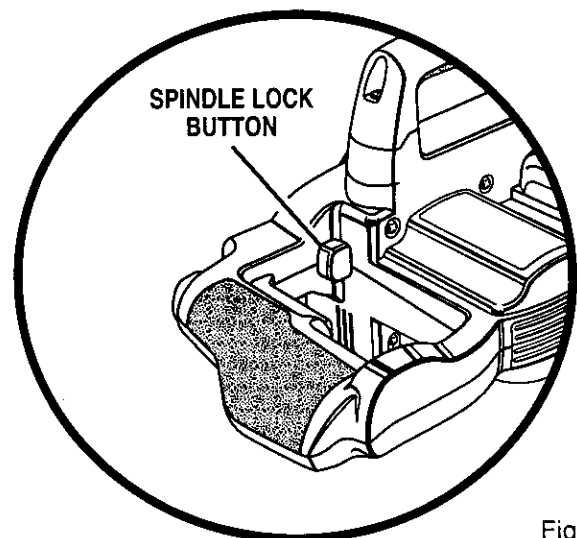

Fig. 20

ADJUSTMENTS

Note: Many of the illustrations in this manual show only portions of your compound miter saw. This is intentional so that we can clearly show points being made in the illustrations. Never operate your saw without all guards securely in place and in good operating condition.

SQUARING THE MITER TABLE TO THE FENCE

See Figures 21– 24.

- Remove battery pack from saw.

⚠ WARNING: Failure to remove battery pack from your saw could result in accidental starting causing possible serious personal injury.

- Push down on the saw arm and pull out the lock pin to release the saw arm.
- Raise saw arm to its full raised position.
- Lift the miter table clamp.
- Rotate the miter table until the pointer is positioned at 0°.
- Push the miter table clamp back down.
- Lay a framing square flat on the miter table. Place one leg of the square against the fence. Place the other leg of the square beside the throat plate in the miter table. The edge of the square and the throat plate in the miter table should be parallel as shown in figure 21.

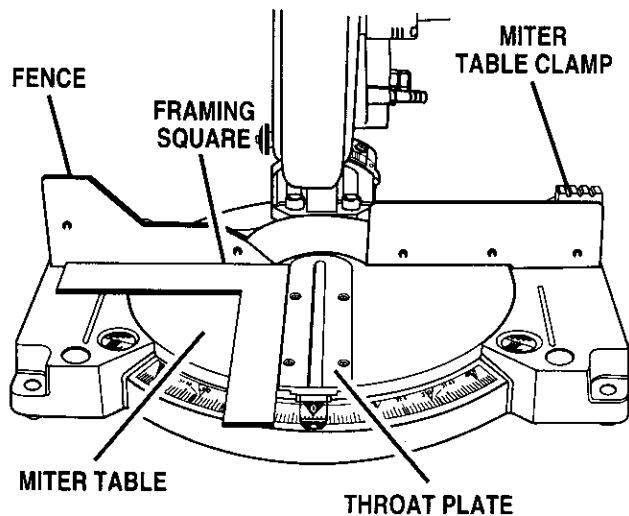

VIEW OF MITER TABLE SQUARE WITH FENCE AND CORRECTLY ADJUSTED

Fig. 21

- If the edge of the framing square and the throat plate in the miter table are not parallel as shown in figures 22 and 23, adjustments are needed.

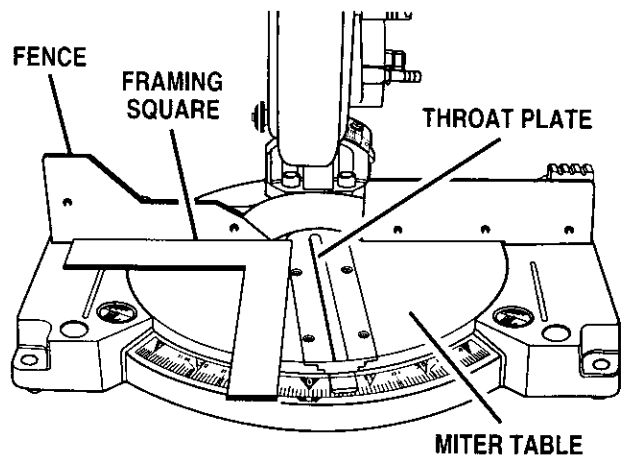

VIEW OF MITER TABLE NOT SQUARE WITH FENCE, ADJUSTMENTS ARE REQUIRED Fig. 22

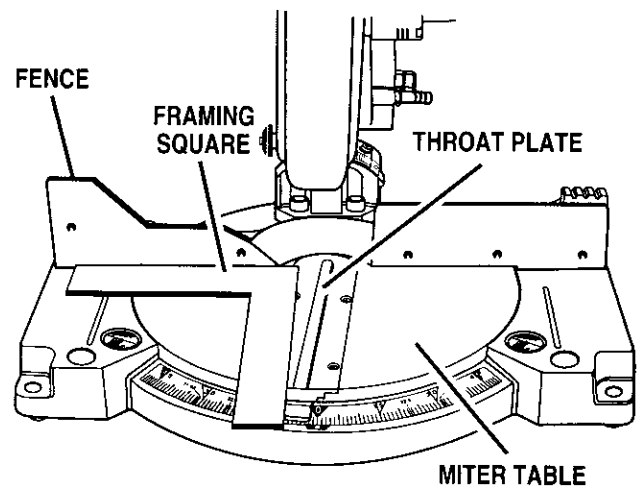

VIEW OF MITER TABLE NOT SQUARE WITH FENCE, ADJUSTMENTS ARE REQUIRED Fig. 23

ADJUSTMENTS

- Using a 6 mm hex key, loosen the socket head screws securing the fence. See Figure 24. Adjust the fence left or right until the framing square and throat plate are parallel.

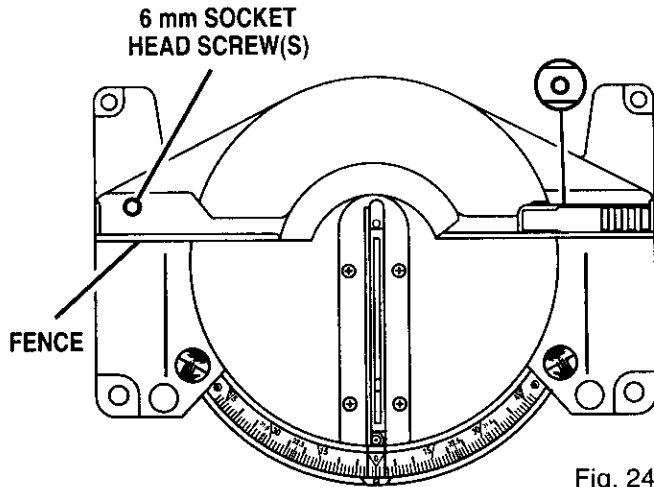

Fig. 24

- The edge of the square and the saw blade should be parallel as shown in figure 25.

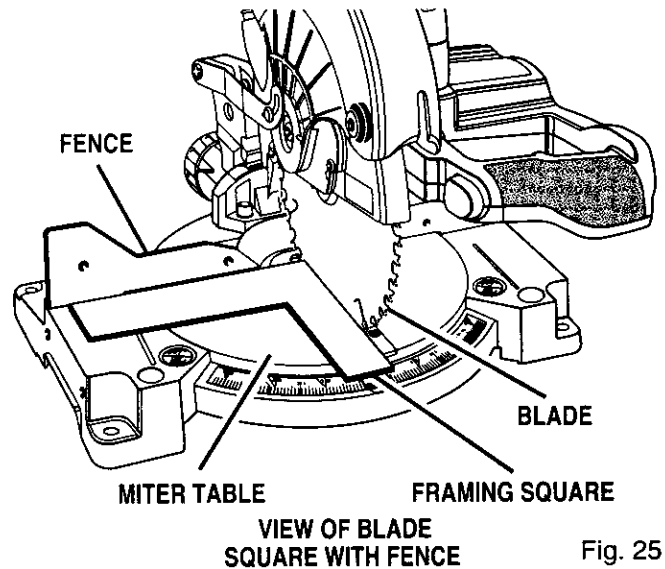

Fig. 25

- Retighten the screws securely and recheck the fence-to-table alignment.

SQUARING THE SAW BLADE TO THE FENCE

See Figures 25 – 28.

- Remove battery pack from saw.

⚠ WARNING: Failure to remove battery pack from your saw could result in accidental starting causing possible serious personal injury.

- Pull the saw arm all the way down and engage the lock pin to hold the saw arm in transport position.
- Lift the miter table clamp.
- Rotate the miter table until the pointer is positioned at 0°.
- Push the miter table clamp back down.
- Lay a framing square flat on the miter table. Place one leg of the square against the fence. Slide the other leg of the square against the flat part of saw blade.

Note: Make sure that the square contacts the flat part of the saw blade, not the blade teeth.

- If the front or back edge of the saw blade angles away from the square as shown in figures 26 and 27, adjustments are needed.

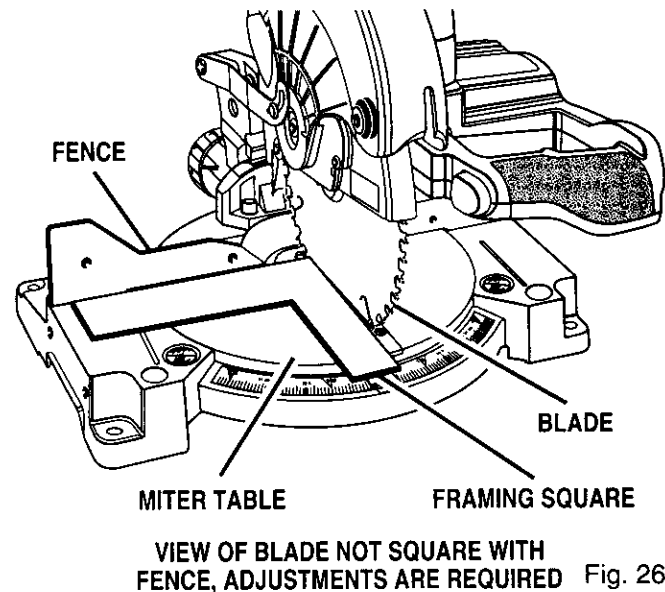
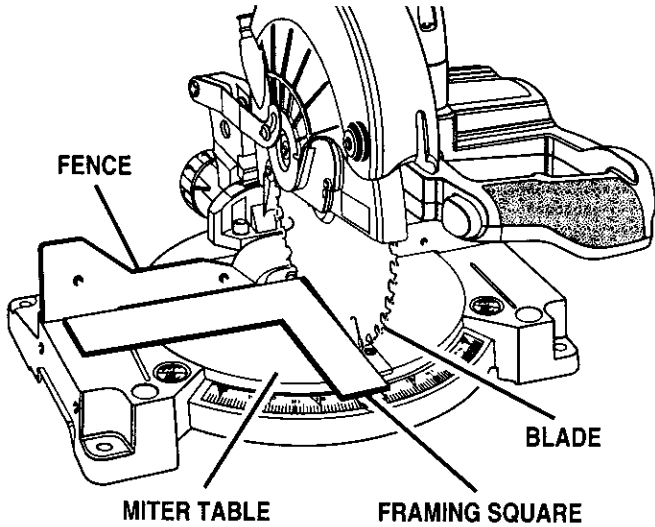

Fig. 26

ADJUSTMENTS



VIEW OF BLADE NOT SQUARE WITH FENCE, ADJUSTMENTS ARE REQUIRED Fig. 27

- Using the 6 mm hex key provided, loosen the socket head screws that secure the mounting bracket to the miter table. See Figure 28.

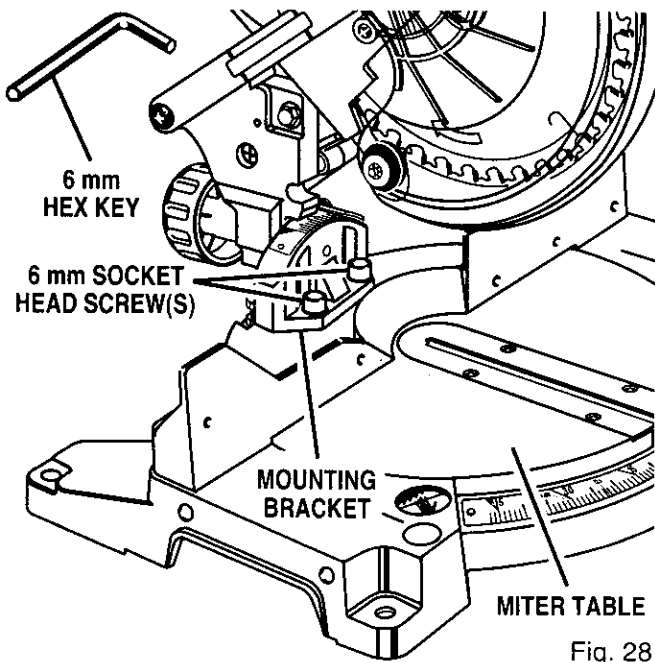

Fig. 28

- Rotate the mounting bracket left or right until the saw blade is parallel with the square.
- Retighten the screws securely and recheck the blade-to-fence alignment.

SQUARING THE BLADE TO THE MITER TABLE

See Figures 29 – 32.

- Remove battery pack from saw.

⚠ WARNING: Failure to remove battery pack from your saw could result in accidental starting causing possible serious personal injury.

- Pull the saw arm all the way down and engage the lock pin to hold the saw arm in transport position.
- Lift up the miter table clamp.
- Rotate the miter table until the pointer is positioned at 0°.
- Push the miter table clamp back down.
- Loosen bevel lock knob and set saw arm at 0° bevel (blade set 90° to miter table). Tighten bevel lock knob.

- Place a combination square against the miter table and the flat part of saw blade.

Note: Make sure that the square contacts the flat part of the saw blade, not the blade teeth.

- Rotate the blade by hand and check the blade-to-table alignment at several points.
- The edge of the square and the saw blade should be parallel as shown in figure 29.

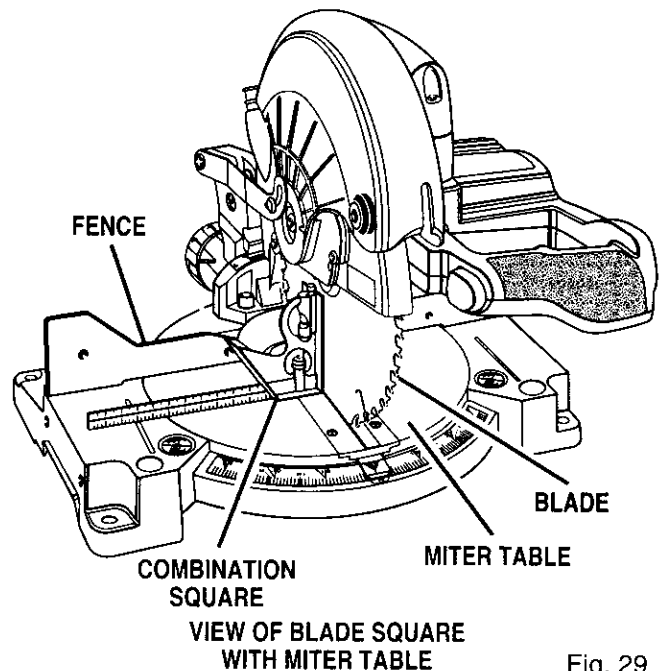
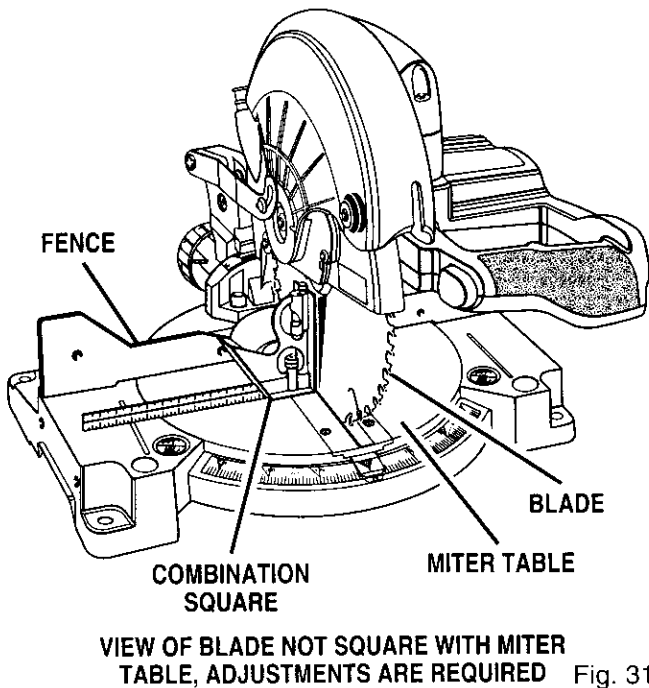
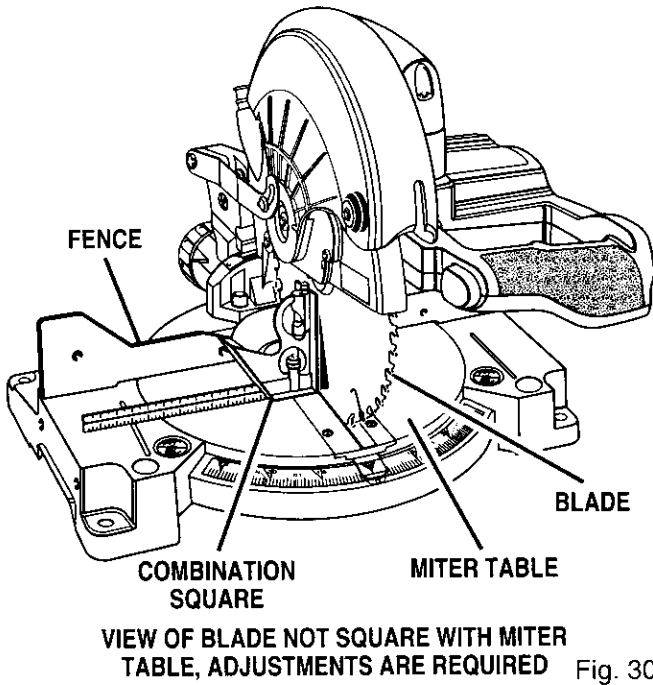

Fig. 29

ADJUSTMENTS

- If the top or bottom of the saw blade angles away from the square as shown in figures 30 and 31, adjustments are needed.



- Using a 10 mm wrench or adjustable wrench, loosen the lock nut securing positive stop adjustment screw. Also loosen bevel lock knob.
- Adjust positive stop adjustment screw to bring saw blade into alignment with the square. See Figure 32.

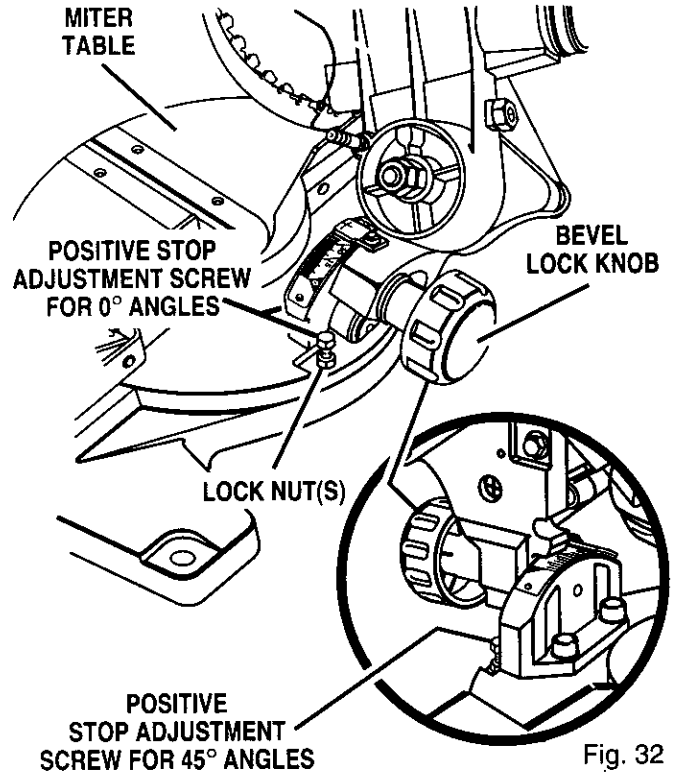

- Retighten bevel lock knob. Next, retighten lock nut securing the positive stop adjustment screw. Recheck blade-to-table alignment.

Note: The above procedure can be used to check blade squareness of the saw blade to the miter table at both 0° and 45° angles.

ADJUSTMENTS

PIVOT ADJUSTMENTS

Note: These adjustments were made at the factory and normally do not require readjustment.

TRAVEL PIVOT ADJUSTMENT

- The saw arm should rise completely to the up position by itself.
- If the saw arm does not raise by itself or if there is play in the pivot joints, have saw repaired by a qualified service technician at a Sears Store or Repair Center to avoid risk of personal injury.

BEVEL PIVOT ADJUSTMENT

- Your compound miter saw should bevel easily by loosening bevel lock knob and tilting saw arm to the left.
- If movement is tight or if there is play in the pivot, have saw repaired by a qualified service technician at your nearest Sears Store or Repair Center to avoid risk of personal injury.

DEPTH STOP

The depth stop limits the blade's downward travel. It allows the blade to go below the miter table enough to maintain full cutting capacities. The depth stop positions the blade 1/4 in. from the miter table support.

Note: The miter table support is located inside miter table.

The depth stop is factory set to provide maximum cutting capacity for the 8-1/4 in. saw blade provided with your saw. Therefore, the saw blade provided should never need adjustments.

However, when the diameter of the blade has been reduced due to sharpening, it may be necessary to adjust the depth stop to provide maximum cutting capacity. Also, when a new blade is installed, it is necessary to check the clearance of the blade to the miter table support before starting the saw. Make adjustments if needed.

DEPTH STOP ADJUSTMENTS

See Figure 33.

- Remove battery pack from saw.
- ⚠ **WARNING:** Failure to remove battery pack from your saw could result in accidental starting causing possible serious personal injury.
- To adjust the depth stop use a 17 mm wrench or adjustable wrench and loosen the hex nut at the rear of the miter saw arm.
- Use the 5 mm hex key provided to adjust the depth stop adjustment screw. The saw blade is lowered by turning the screw counterclockwise and raised by turning the screw clockwise.

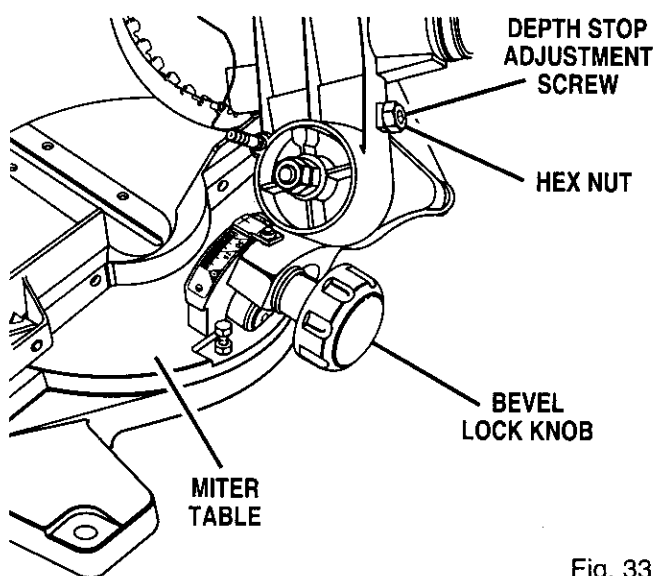

Fig. 33

- Lower the blade into the throat plate of the miter table. Check blade clearance and maximum cutting distance (distance from fence where blade enters) to front of miter table slot.
- Readjust if necessary.
- ⚠ **WARNING:** Do not start your compound miter saw without checking for interference between the blade and the miter table support. Damage could result to the blade if it strikes the miter table support during operation of the saw.
- Tighten the hex nut with a 17 mm wrench or adjustable wrench.
- To prevent the depth stop adjustment screw from turning while tightening the hex nut, carefully hold it with the hex key while tightening the hex nut.

OPERATION

- ⚠ WARNING:** Always wear safety goggles or safety glasses with side shields when operating tools. Failure to do so could result in objects being thrown into your eyes, resulting in possible serious injury.

After all parts have been assembled properly and adjustments have been made to saw, battery pack can now be attached to saw.

TO ATTACH BATTERY PACK TO SAW

See Figure 34.

- Align raised ribs on battery pack with grooves on bottom of saw, then attach battery pack to saw as shown in figure 34.

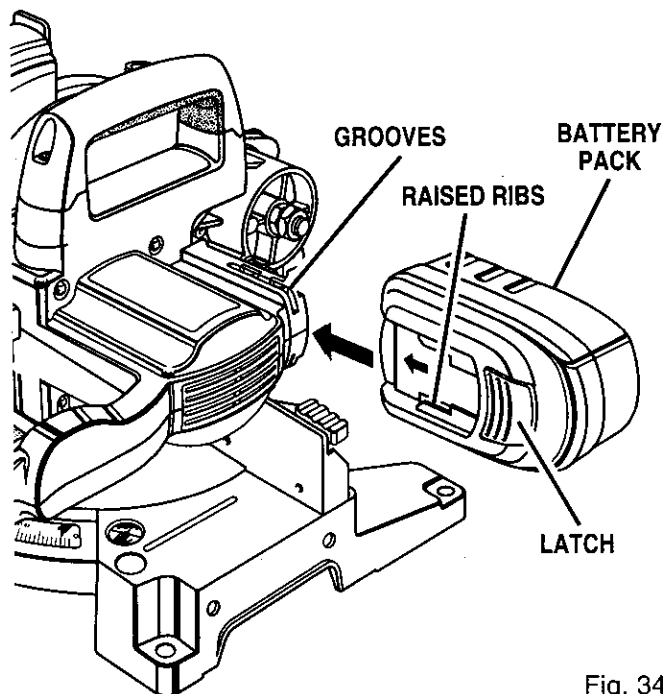

Fig. 34

- Make sure latch on battery pack snaps into place and battery pack is secured to saw before beginning operation.
- ⚠ CAUTION:** When attaching battery pack to your saw, be sure raised ribs and grooves align properly and latch snaps into place properly. Improper assembly can cause damage to saw and battery pack.

TO REMOVE BATTERY PACK

See Figure 35.

- Depress latch located on front of battery pack (1) to release battery pack.
- Pull forward on battery pack (2) to remove from saw.

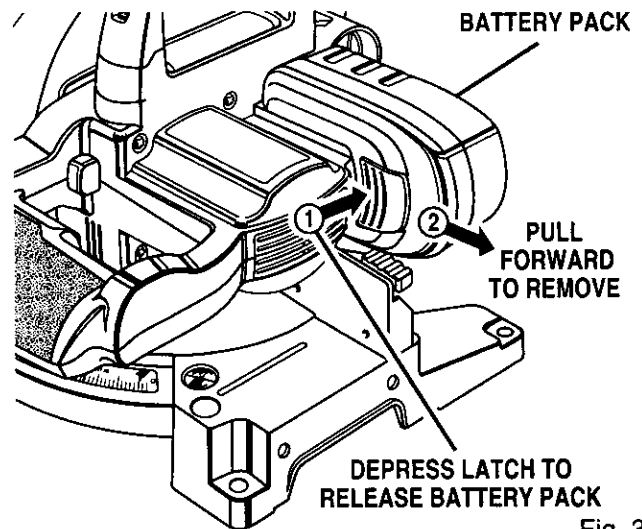

Fig. 35

APPLICATIONS

(Use only for the purposes listed below)

- Cross cutting wood and plastic.
- Cross cutting miters, joints, etc. for picture frames, moldings, door casings, and fine joinery.

Note: The 24 tooth crosscut blade provided is fine for most wood cutting operations. For fine joinery cuts or cutting plastic, use one of the accessory blades available from your nearest Sears store.

- ⚠ WARNING:** Before starting any cutting operation, clamp or bolt your compound miter saw to a workbench. Never operate your miter saw on the floor or in a crouched position. Failure to heed this warning can result in serious personal injury.

CUTTING WITH YOUR COMPOUND MITER SAW

- ⚠ WARNING:** When using a work clamp or C-clamp to secure your workpiece, clamp workpiece on one side of the blade only. The workpiece must remain free on one side of the blade to prevent the blade from binding in workpiece. The workpiece binding the blade will cause motor stalling and kickback. This situation could cause an accident resulting in possible serious personal injury.

OPERATION

CROSSCUTTING

See Figure 36.

A crosscut is made by cutting across the grain of the workpiece. A 90° crosscut is made with the miter table set at the zero degree position. Miter crosscuts are made with the miter table set at some angle other than zero.

TO CROSSCUT WITH YOUR MITER SAW:

- Pull out the lock pin and lift saw arm to its full height.
- Lift the miter table clamp.
- Rotate the miter table until the pointer aligns with the desired angle on the miter scale.
- Push the miter table clamp back down.

Note: You can quickly locate 0°, 22-1/2° left or right, and 45° left or right on the scale. The miter table can be seated in one of the positive stop notches, located in the miter table frame.

- ▲ **WARNING:** To avoid serious personal injury, always push the miter table clamp back down before making a cut. Failure to do so could result in movement of the miter table while making a cut.

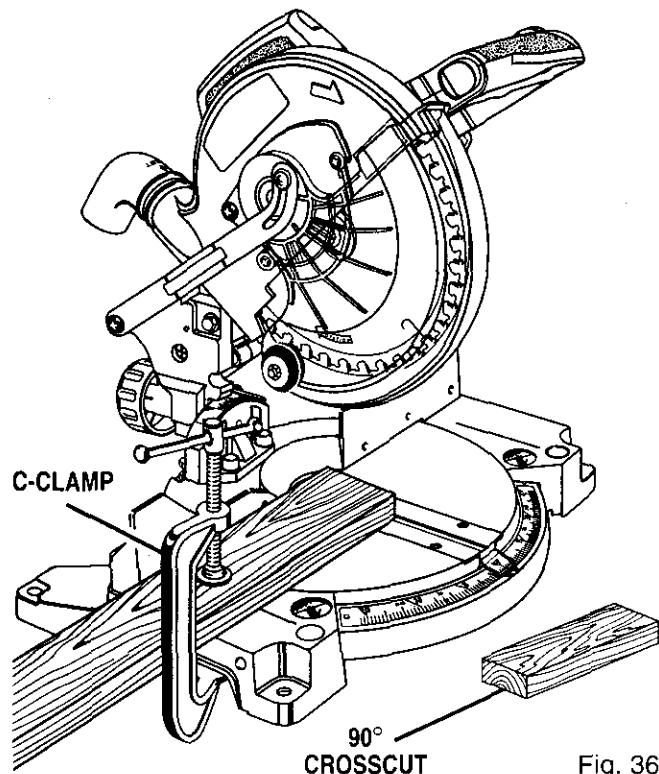

- Place the workpiece flat on the miter table with one edge securely against the fence. If the board is warped, place the convex side against the fence. If the concave edge of a board is placed against the fence, the board could collapse on the blade at the end of the cut, jamming the blade. See Figures 43 and 44.
- When cutting long pieces of lumber or molding, support the opposite end of the stock with a roller stand or with a work surface level with the saw table.
- Align cutting line on the workpiece with the edge of saw blade.
- Grasp the stock firmly with one hand and secure it against the fence. Use the optional work clamp or a C-clamp to secure the workpiece when possible. See Figure 36.

- ▲ **WARNING:** To avoid serious personal injury, keep your hands outside the no hands zone; at least 3 in. from blade. Never perform any cutting operation freehand (without holding workpiece against the fence). The blade could grab the workpiece if it slips or twists.

- Before turning on the saw, perform a dry run of the cutting operation just to make sure that no problems will occur when the cut is made.
- Grasp the saw handle firmly, depress the lock-off button, then squeeze the switch trigger. Allow several seconds for the blade to reach maximum speed.
- Slowly lower the blade into and through the workpiece. See Figure 36.
- Release the switch trigger and allow the saw blade to stop rotating before raising the blade out of workpiece. Wait until the electric brake stops blade from turning before removing the workpiece from the miter table.

OPERATION

BEVEL CUT

See Figures 37 and 38.

A bevel cut is made by cutting across the grain of the workpiece with the blade angled to the fence and miter table. A bevel cut is made with the miter table set at the zero degree position and the blade set at an angle between 0° and 45°.

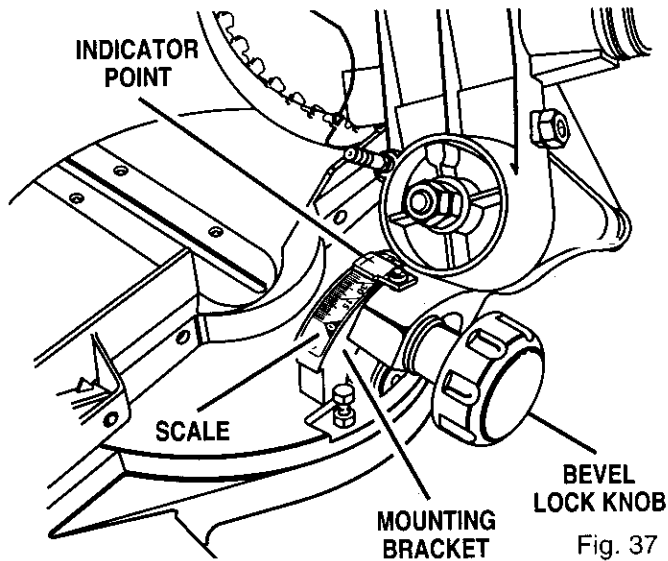

Fig. 37

TO BEVEL CUT WITH YOUR MITER SAW:

- Pull out the lock pin and lift saw arm to its full height.
- Lift the miter table clamp.
- Rotate the miter table until the pointer aligns with zero on the miter scale.
- Push the miter table clamp back down.

Note: You can quickly locate zero on the scale. The miter table can be seated in one of the built-in positive stop notches, located in the miter table frame.

⚠ WARNING: To avoid serious personal injury, always push the miter table clamp back down before making a cut. Failure to do so could result in movement of the miter table while making a cut.

- Loosen the bevel lock knob and move the saw arm to the left to the desired bevel angle.
- Bevel angles can be set from 0° to 45°.
- Align the indicator point with the desired angle.
- Once the saw arm has been set at the desired angle, securely tighten the bevel lock knob.
- Place the workpiece flat on the miter table with one edge securely against the fence. If the board is warped, place the convex side against the fence. If the concave edge of a board is placed against the fence, the board could collapse on the

blade at the end of the cut, jamming the blade. See Figures 43 and 44.

- When cutting long pieces of lumber or molding, support the overhanging end(s) of the stock with a roller stand or with a work surface level with the saw table.
- Align the cutting line on the workpiece with the edge of saw blade.
- Grasp the stock firmly with one hand and secure it against the fence. Use the optional work clamp or a C-clamp to secure the workpiece when possible. See Figure 38.

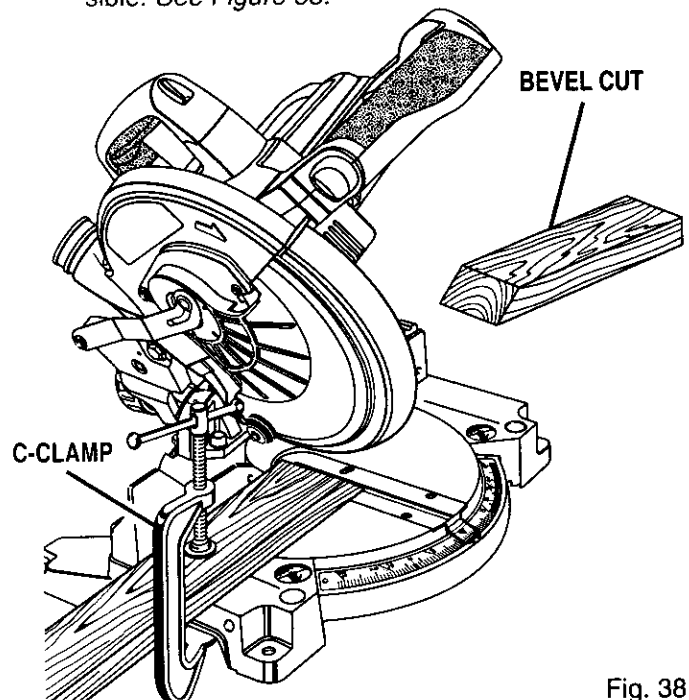

Fig. 38

⚠ WARNING: To avoid serious personal injury, keep your hands outside the no hands zone; at least 3 in. from blade. Never perform any cutting operation freehand (without holding workpiece against the fence). The blade could grab the workpiece if it slips or twists.

- Before turning on the saw, perform a dry run of the cutting operation just to make sure that no problems will occur when the cut is made.
- Grasp the saw handle firmly, depress the lock-off button, then squeeze the switch trigger. Allow several seconds for the blade to reach maximum speed.
- Slowly lower the blade into and through the workpiece. See Figure 38.
- Release the switch trigger and allow the saw blade to stop rotating before raising the blade out of workpiece. Wait until the electric brake stops blade from turning before removing the workpiece from miter table.

OPERATION

COMPOUND MITER CUT

See Figures 39 and 40.

A compound miter cut is a cut made using a miter angle and a bevel angle at the same time. This type of cut is used to make picture frames, cut molding, make boxes with sloping sides, and for certain roof framing cuts.

To make this type of cut the miter table must be rotated to the correct angle and the saw arm must be tilted to the correct bevel angle. Care should always be taken when making compound miter setups due to the interaction of the two angle settings.

Adjustments of miter and bevel settings are interdependent with one another. Each time you adjust the miter setting you change the effect of the bevel setting. Also, each time you adjust the bevel setting you change the effect of the miter setting.

It may take several settings to obtain the desired cut. The first angle setting should be checked after setting the second angle, since adjusting the second angle affects the first.

Once the two correct settings for a particular cut have been obtained, always make a test cut in scrap material before making a finish cut in good material.

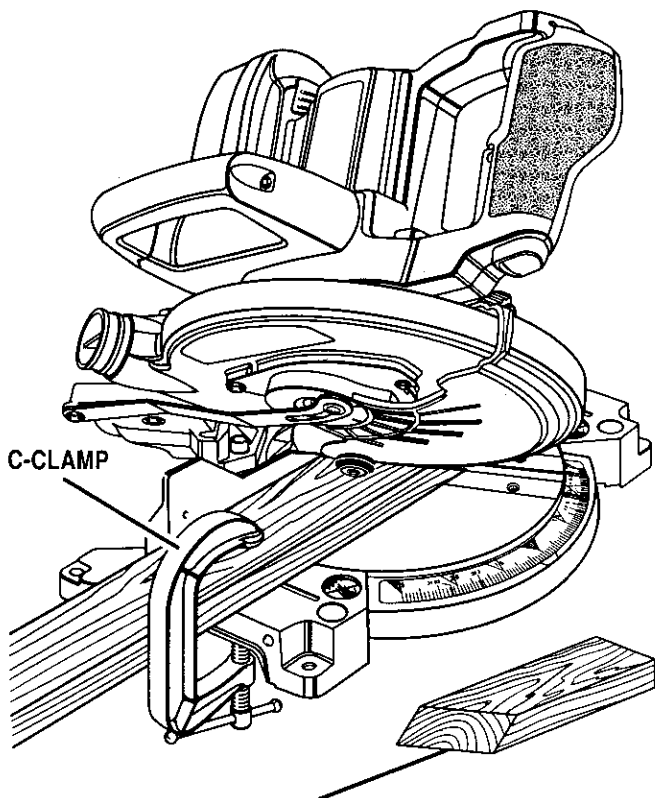

COMPOUND MITER CUT

Fig. 39

TO MAKE A COMPOUND CUT WITH YOUR MITER SAW:

- Pull out the lock pin and lift saw arm to its full height.
- Lift the miter table clamp.
- Rotate the miter table until the pointer aligns with the desired angle on the miter scale.
- Push the miter table clamp back down.

Note: You can quickly locate 0°, 22-1/2° left or right, and 45° left or right on the scale. The miter table can be seated in one of the positive stop notches, located in the miter table frame.

⚠ WARNING: To avoid serious personal injury, always push the miter table clamp back down before making a cut. Failure to do so could result in movement of the miter table while making a cut.

- Loosen the bevel lock knob and move the saw arm to the left to the desired bevel angle.
- Bevel angles can be set from 0° to 45°.
- Align the indicator point with the desired angle.
- Once the saw arm has been set at the desired angle, securely tighten the bevel lock knob.
- Recheck miter angle setting. Make a test cut in scrap material.
- Place the workpiece flat on the miter table with one edge securely against the fence. If the board is warped, place the convex side against the fence. If the concave edge of a board is placed against the fence, the board could collapse on the blade at the end of the cut, jamming the blade. See Figures 43 and 44.
- When cutting long pieces of lumber or molding, support the opposite end of the stock with a roller stand or with a work surface level with the saw table.
- Align the cutting line on the workpiece with the edge of saw blade.
- Grasp the stock firmly with one hand and secure it against the fence. Use the optional work clamp or a C-clamp to secure the workpiece when possible. See Figure 39.

⚠ WARNING: To avoid serious personal injury, always keep your hands outside the no hands zone; at least 3 in. from blade. Never perform any cutting operation freehand (without holding workpiece against the fence). The blade could grab the workpiece if it slips or twists.

OPERATION

- Before turning on the saw, perform a dry run of the cutting operation just to make sure that no problems will occur when the cut is made.
- Grasp the saw handle firmly, depress the lock-off button, then squeeze the switch trigger. Allow several seconds for the blade to reach maximum speed.
- Slowly lower the blade into and through the workpiece. *See Figures 39 and 40.*
- Release the switch trigger and allow the saw blade to stop rotating before raising the blade out of workpiece. Wait until the electric brake stops blade from turning before removing the workpiece from miter table.

SUPPORT LONG WORKPIECES

See Figure 41.

Long workpieces need extra supports. Supports should be placed along the workpiece so it does not sag. The support should let the workpiece lay flat on the base of the saw and work table during the cutting operation. Use the optional work clamp or a C-clamp to secure the workpiece.

⚠ WARNING: To avoid serious personal injury, always keep your hands outside the no hands zone; at least 3 in. from blade. Never perform any cutting operation freehand (without holding workpiece against the fence). The blade could grab the workpiece if it slips or twists.

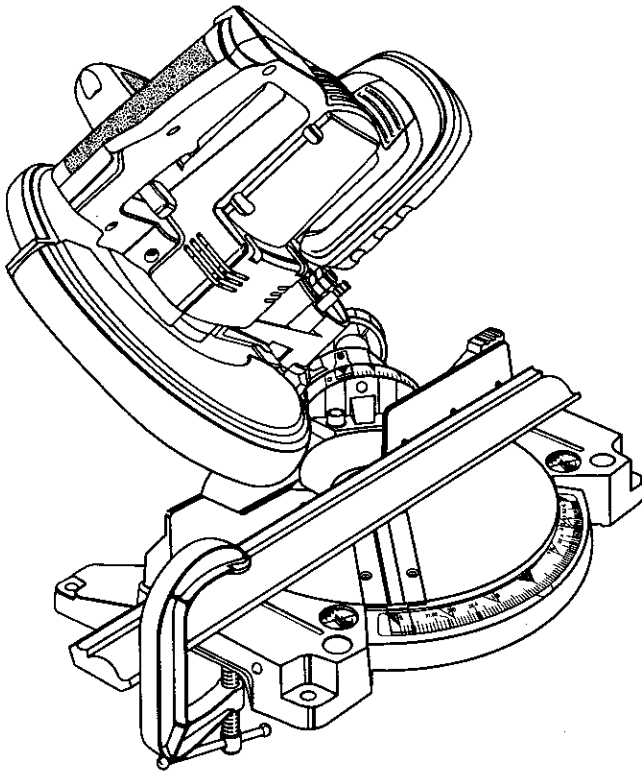

45° X 45° COMPOUND
MITER CUT

Fig. 40

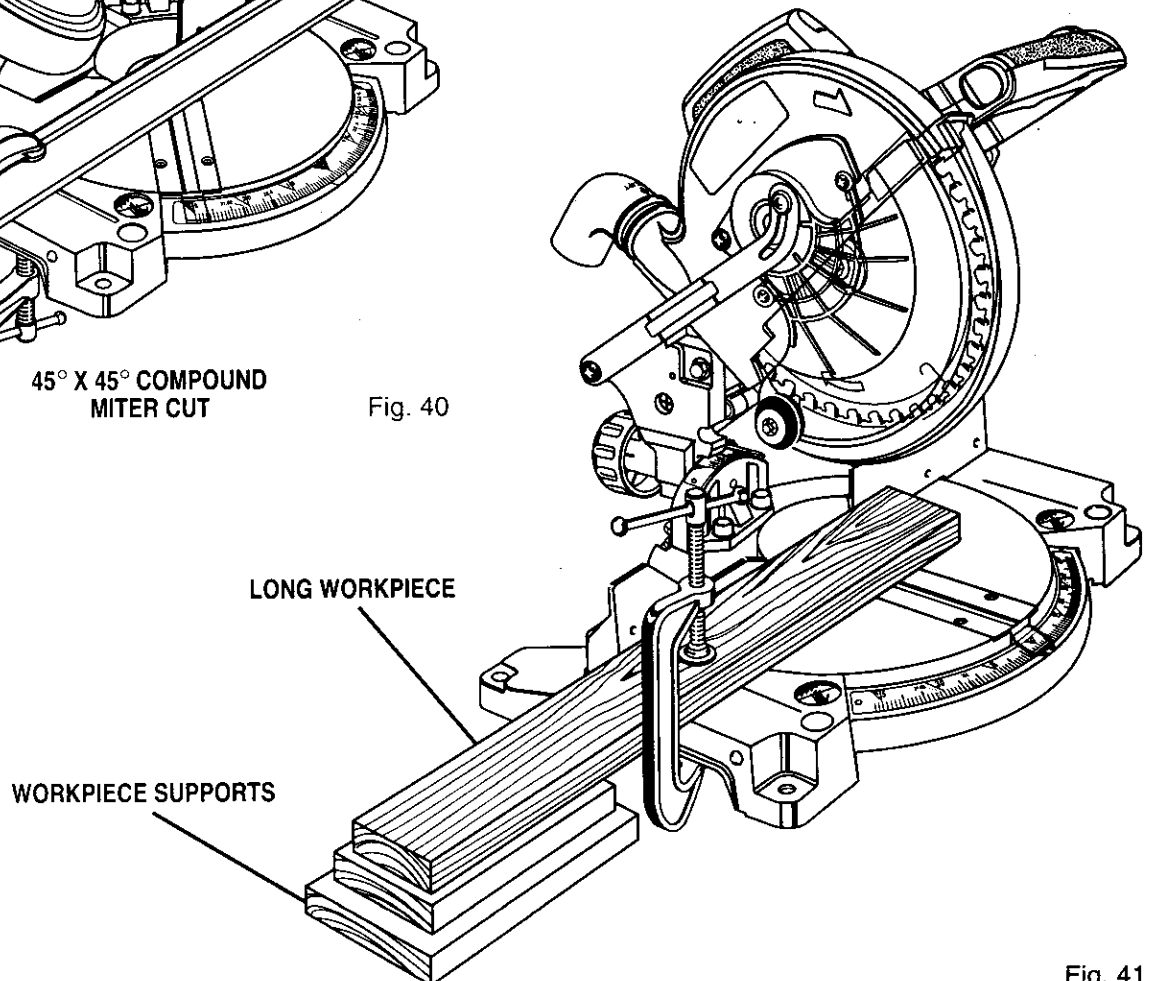

LONG WORKPIECE

WORKPIECE SUPPORTS

Fig. 41

OPERATION

CUTTING COMPOUND MITERS

To aid in making the correct settings, the compound angle setting chart below has been provided. Since compound cuts are the most difficult to accurately obtain, trial cuts should be made in scrap material, and much thought and planning made, prior to making your required cut.

PITCH OF SIDE	NUMBER OF SIDES						
	4	5	6	7	8	9	10
0°	M- 45.00° B- 0.00°	M- 36.00° B- 0.00°	M- 30.00° B- 0.00°	M- 25.71° B- 0.00°	M- 22.50° B- 0.00°	M- 20.00° B- 0.00°	M- 18.00° B- 0.00°
5°	M- 44.89° B- 3.53°	M- 35.90° B- 2.94°	M- 29.91° B- 2.50°	M- 25.63° B- 2.17°	M- 22.42° B- 1.91°	M- 19.93° B- 1.71°	M- 17.94° B- 1.54°
10°	M- 44.56° B- 7.05°	M- 35.58° B- 5.86°	M- 29.62° B- 4.98°	M- 25.37° B- 4.32°	M- 22.19° B- 3.81°	M- 19.72° B- 3.40°	M- 17.74° B- 3.08°
15°	M- 44.01° B- 10.55°	M- 35.06° B- 8.75°	M- 29.15° B- 7.44°	M- 24.95° B- 6.45°	M- 21.81° B- 5.68°	M- 19.37° B- 5.08°	M- 17.42° B- 4.59°
20°	M- 43.22° B- 14.00°	M- 34.32° B- 11.60°	M- 28.48° B- 9.85°	M- 24.35° B- 8.53°	M- 21.27° B- 7.52°	M- 18.88° B- 6.72°	M- 16.98° B- 6.07°
25°	M- 42.19° B- 17.39°	M- 33.36° B- 14.38°	M- 27.62° B- 12.20°	M- 23.56° B- 10.57°	M- 20.58° B- 9.31°	M- 18.26° B- 8.31°	M- 16.41° B- 7.50°
30°	M- 40.89° B- 20.70°	M- 32.18° B- 17.09°	M- 26.57° B- 14.48°	M- 22.64° B- 12.53°	M- 19.73° B- 11.03°	M- 17.50° B- 9.85°	M- 15.72° B- 8.89°
35°	M- 39.32° B- 23.93°	M- 30.76° B- 19.70°	M- 25.31° B- 16.67°	M- 21.53° B- 14.41°	M- 18.74° B- 12.68°	M- 16.60° B- 11.31°	M- 14.90° B- 10.21°
40°	M- 37.45° B- 27.03°	M- 29.10° B- 22.20°	M- 23.86° B- 18.75°	M- 20.25° B- 16.19°	M- 17.60° B- 14.24°	M- 15.58° B- 12.70°	M- 13.98° B- 11.46°
45°	M- 35.26° B- 30.00°	M- 27.19° B- 24.56°	M- 22.21° B- 20.70°	M- 18.80° B- 17.87°	M- 16.32° B- 15.70°	M- 14.43° B- 14.00°	M- 12.94° B- 12.62°
50°	M- 32.73° B- 32.80°	M- 25.03° B- 26.76°	M- 20.36° B- 22.52°	M- 17.20° B- 19.41°	M- 14.91° B- 17.05°	M- 13.17° B- 15.19°	M- 11.80° B- 13.69°
55°	M- 29.84° B- 35.40°	M- 22.62° B- 28.78°	M- 18.32° B- 24.18°	M- 15.44° B- 20.82°	M- 13.36° B- 18.27°	M- 11.79° B- 16.27°	M- 10.56° B- 14.66°
60°	M- 26.57° B- 37.76°	M- 19.96° B- 30.60°	M- 16.10° B- 25.66°	M- 13.54° B- 22.07°	M- 11.70° B- 19.35°	M- 10.31° B- 17.23°	M- 9.23° B- 15.52°
65°	M- 22.91° B- 39.86°	M- 17.07° B- 32.19°	M- 13.71° B- 26.95°	M- 11.50° B- 23.16°	M- 9.93° B- 20.29°	M- 8.74° B- 18.06°	M- 7.82° B- 16.26°
70°	M- 18.88° B- 41.64°	M- 13.95° B- 33.53°	M- 11.17° B- 28.02°	M- 9.35° B- 24.06°	M- 8.06° B- 21.08°	M- 7.10° B- 18.75°	M- 6.34° B- 16.88°
75°	M- 14.51° B- 43.08°	M- 10.65° B- 34.59°	M- 8.50° B- 28.88°	M- 7.10° B- 24.78°	M- 6.12° B- 21.69°	M- 5.38° B- 19.29°	M- 4.81° B- 17.37°
80°	M- 9.85° B- 44.14°	M- 7.19° B- 35.37°	M- 5.73° B- 29.50°	M- 4.78° B- 25.30°	M- 4.11° B- 22.14°	M- 3.62° B- 19.68°	M- 3.23° B- 17.72°
85°	M- 4.98° B- 44.78°	M- 3.62° B- 35.84°	M- 2.88° B- 29.87°	M- 2.40° B- 25.61°	M- 2.07° B- 22.41°	M- 1.82° B- 19.92°	M- 1.62° B- 17.93°
90°	M- 0.00° B- 45.00°	M- 0.00° B- 36.00°	M- 0.00° B- 30.00°	M- 0.00° B- 25.71°	M- 0.00° B- 22.50°	M- 0.00° B- 20.00°	M- 0.00° B- 18.00°

Each B (Bevel) and M (Miter) Setting is Given to the Closest 0.005°.

COMPOUND-ANGLE SETTINGS FOR POPULAR STRUCTURES

OPERATION

CUTTING CROWN MOLDING

Your compound miter saw does an excellent job of cutting crown molding. In general, compound miter saws do a better job of cutting crown molding than any other tool made.

In order to fit properly, crown molding must be compound mitered with extreme accuracy.

The two contact surfaces on a piece of crown molding that fit flat against the ceiling and the wall of a room are at angles that, when added together, equal exactly 90° . Most crown molding has a top rear angle (the section that fits flat against the ceiling) of 52° and a bottom rear angle (the section that fits flat against the wall) of 38° .

LAYING MOLDING FLAT ON THE MITER TABLE

See Figure 42.

To use this method for accurately cutting crown molding for a 90° inside or outside corner, lay the molding with its broad back surface flat on the miter table and against the fence.

When setting the bevel and miter angles for compound miters, remember that the settings are interdependent; changing one angle changes the other angle as well.

Keep in mind that the angles for crown moldings are very precise and difficult to set. Since it is very easy for these angles to shift, all settings should first be tested on scrap molding. Also, most walls do not have angles of exactly 90° , therefore, you will need to fine tune your settings.

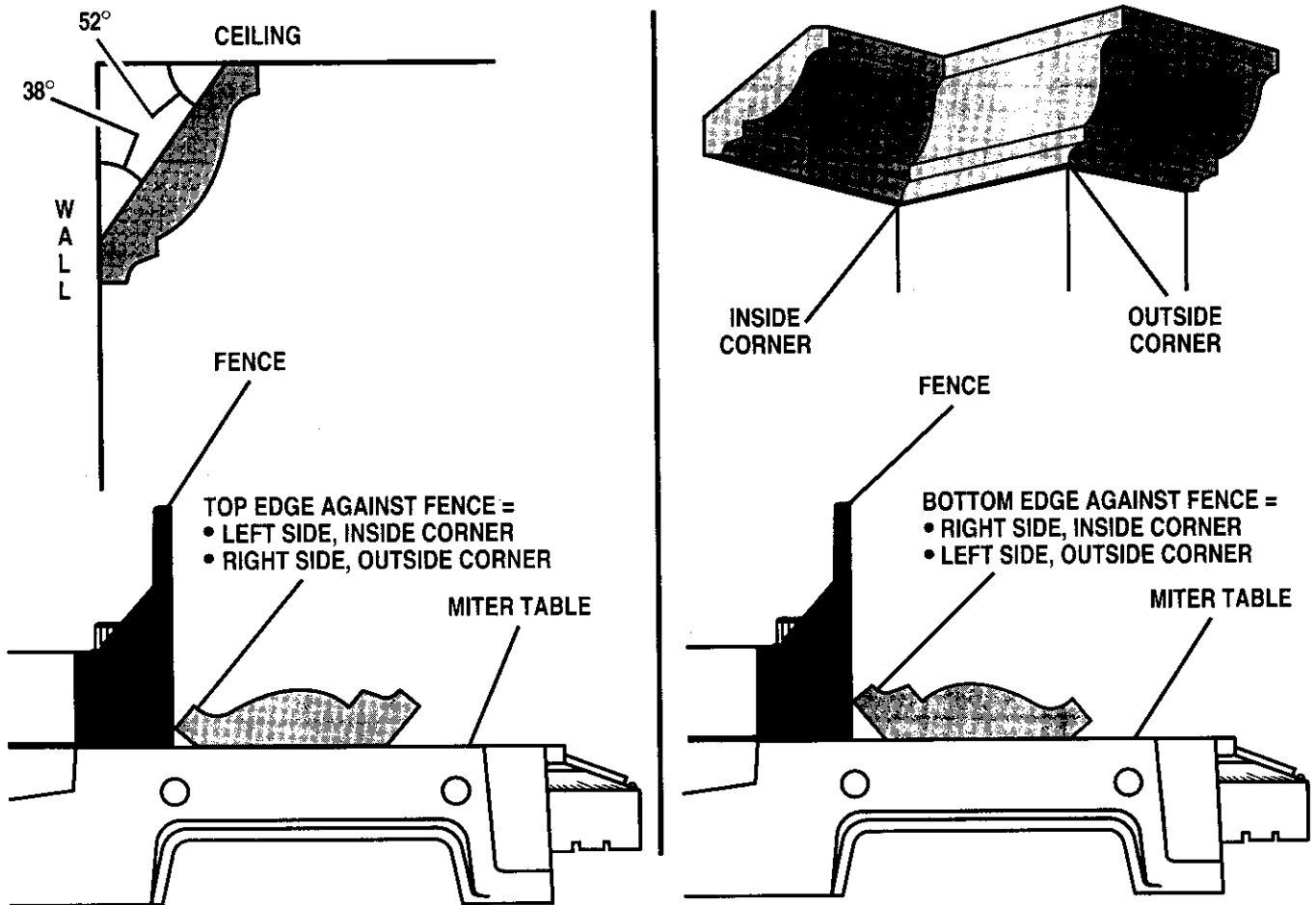

CROWN MOLDING FLAT ON MITER TABLE

Fig. 42

OPERATION

When cutting crown molding by this method the bevel angle should be set at 33.85°. The miter angle should be set at 31.62° either right or left, depending on the desired cut for the application. See the chart below for correct angle settings and correct positioning of crown molding on miter table.

The settings in the chart below can be used for cutting All Standard (U.S.) crown molding with 52° and 38° angles. The crown molding is placed flat on the miter table using the compound features of your miter saw.

Bevel Angle Setting	Type of Cut
33.85°	Left side, inside corner 1. Top edge of molding against fence 2. Miter table set right 31.62° 3. Save left end of cut
33.85°	Right side, inside corner 1. Bottom edge of molding against fence 2. Miter table set left 31.62° 3. Save left end of cut
33.85°	Left side, outside corner 1. Bottom edge of molding against fence 2. Miter table set left 31.62° 3. Save right end of cut
33.85°	Right side, outside corner 1. Top edge of molding against fence 2. Miter table set right 31.62° 3. Save right end of cut

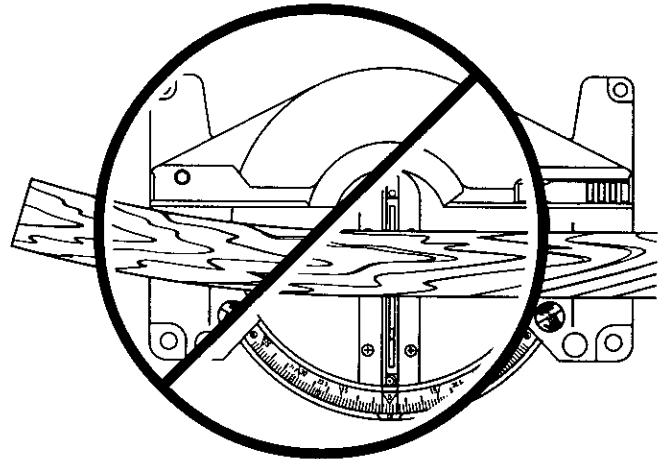

WRONG

Fig. 44

When cutting warped material, always make sure it is positioned on the miter table with the convex side against the fence as shown in figure 43.

If the warped material is positioned the wrong way as shown in figure 44, it will pinch the blade near the completion of the cut.

⚠ WARNING: To avoid a kickback and to avoid serious personal injury, never position the concave edge of bowed or warped material against the fence.

CUTTING WARPED MATERIAL

See Figures 43 and 44.

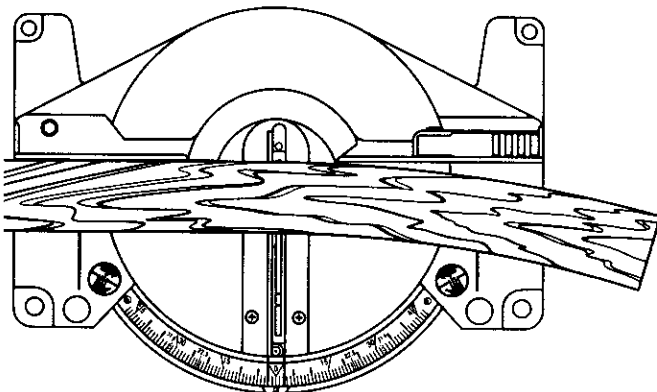

RIGHT

Fig. 43

MAINTENANCE

⚠ WARNING: When servicing, use only identical Craftsman replacement parts. Use of any other part may create a hazard or cause product damage.

Avoid using solvents when cleaning plastic parts. Most plastics are susceptible to damage from various types of commercial solvents and may be damaged by their use. Use clean cloths to remove dirt, dust, oil, grease, etc.

⚠ WARNING: Do not at any time let brake fluids, gasoline, petroleum-based products, penetrating oils, etc. come in contact with plastic parts. They contain chemicals that can damage, weaken or destroy plastic.

Do not abuse power tools. Abusive practices can damage tool as well as workpiece.

Only the parts shown on parts list, pages 34 thru 39, are intended to be repaired or replaced by the customer. All other parts should be replaced at a Sears Service Center.

⚠ WARNING: Do not attempt to modify this tool or create accessories not recommended for use with this tool. Any such alteration or modification is misuse and could result in a hazardous condition leading to possible serious personal injury.

BATTERIES

The battery pack for this saw is equipped with 15 nickel-cadmium rechargeable batteries. Length of service from each charging will depend on the type of work you are doing.

The batteries have been designed to provide maximum trouble free life. However, like all batteries, they will eventually wear out. **Do not** disassemble battery pack and attempt to replace the batteries. Handling of these batteries, especially when wearing rings and jewelry, could result in a serious burn.

To obtain the longest possible battery life, we suggest the following:

- Store and charge your batteries in a cool area. Temperatures above normal room temperature will shorten battery life.
- Never store batteries in a discharged condition. Recharge them immediately after they are discharged.
- All batteries gradually lose their charge. The higher the temperature the quicker they lose their charge. If you store your tool for long periods of time without using it, recharge the batteries every month or two. This practice will prolong battery life.



To preserve natural resources, please recycle or dispose of batteries properly.

This product contains nickel-cadmium batteries. Local, state or federal laws may prohibit disposal of nickel-cadmium batteries in ordinary trash.

Consult your local waste authority for information regarding available recycling and/or disposal options.

BATTERY PACK REMOVAL AND PREPARATION FOR RECYCLING

⚠ WARNING: Upon removal, cover the battery pack's terminals with heavy duty adhesive tape. Do not attempt to destroy or disassemble battery pack or remove any of its components. Nickel-cadmium batteries must be recycled or disposed of properly. Also, never touch both terminals with metal objects and/or body parts as short circuit may result. Keep away from children. Failure to comply with these warnings could result in fire and/or serious injury.

NOTES

CRAFTSMAN 18 VOLT PROFESSIONAL CORDLESS COMPOUND MITER / TRIM SAW - MODEL NUMBER 315.212180

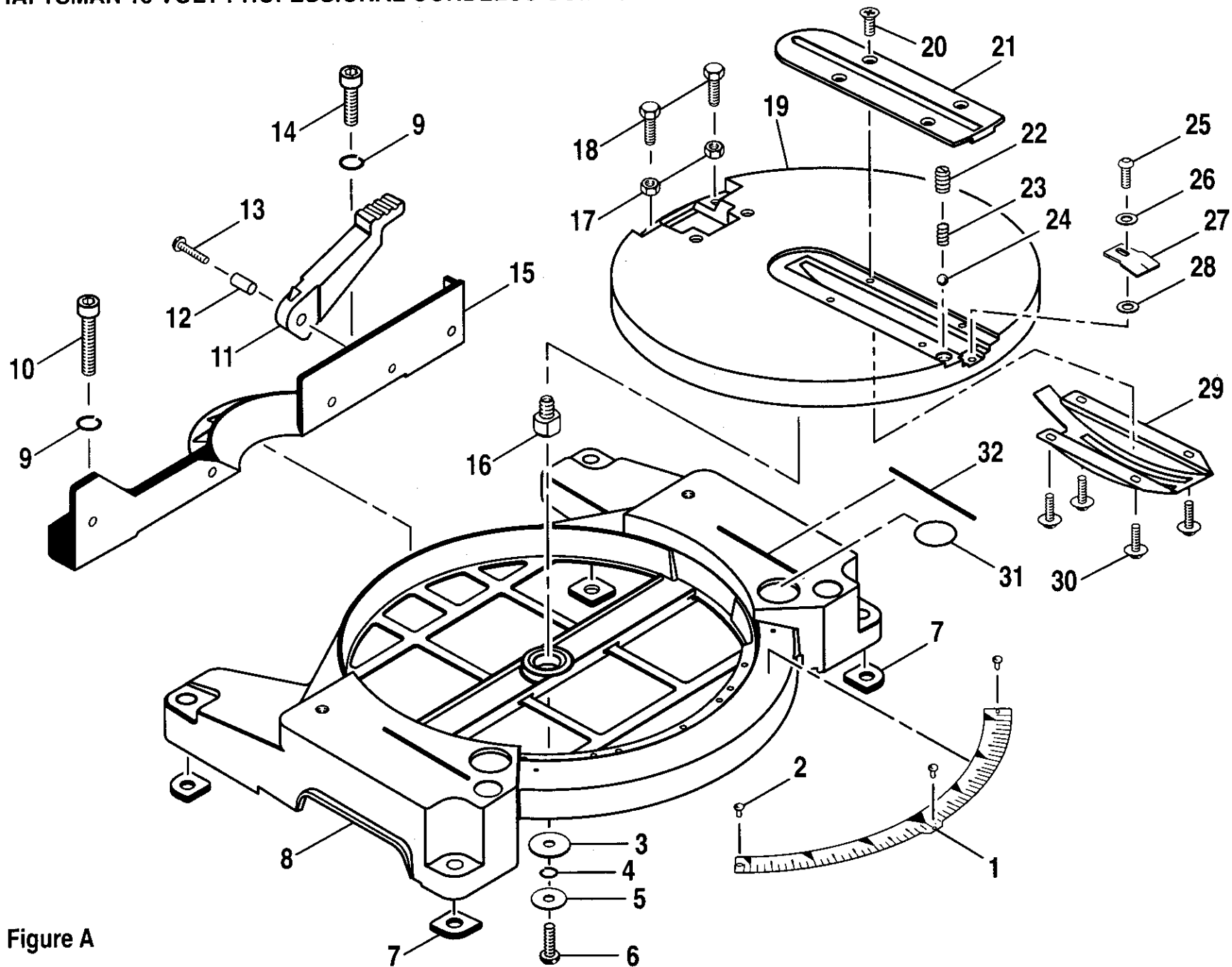

Figure A

CRAFTSMAN 18 VOLT PROFESSIONAL CORDLESS COMPOUND MITER / TRIM SAW – MODEL NUMBER 315.212180

The model number will be found on a plate attached to the motor housing. Always mention the model number in all correspondence regarding your **COMPOUND MITER / TRIM SAW** or when ordering repair parts.

PARTS LIST FOR FIGURE A

KEY NO.	PART NUMBER	DESCRIPTION	QUAN.	KEY NO.	PART NUMBER	DESCRIPTION	QUAN.
1	980146-001	Miter Scale	1	17	STD840610	** Hex Nut	2
2	976729-001	Rivet	3	18	6616916	Hex Hd. Screw (M6 x 20L)	2
3	980137-001	Washer	1	19	6447301	Table	1
4	980105-001	Washer	1	20	160030-400	Screw (Flat Hd.)	4
5	980203-001	Washer	1	21	980130-001	Throat Plate	1
6	980136-001	Screw (M5 X 15L Pan Hd.)	1	22	5537201	Plastic Screw (M10 x 12.7L)	1
7	5530301	Rubber Pad	4	23	6881501	Compression Spring	1
8	6447401	Table Frame	1	24	6881601	Steel Ball (ø6.0mm)	1
9	980096-001	Washer	2	25	130010-401	Screw (M4 x 8L)	1
10	980102-001	Hex Cap Screw	1	26	980124-001	Washer	1
11	980112-001	Miter Table Clamp	1	27	980131-001	Miter Scale Indicator	1
12	6616914	Sleeve	1	28	6875901	Flat Washer	1
13	980113-001	Screw (Includes Key No. 12)	1	29	6384001	Cover Plate	1
14	980111-001	Hex Cap Screw (M8 X 20L)	1	30	6621214	Screw (M4 x 9L)	4
15	980110-001	Fence	1	31	980144-001	No Hands Label	2
16	6887001	Nut (Special) (M8 x 1.25 x 17.5L)	1	32	980143-001	Line Label	2

**** Available From Division 98 - Source 980.00**

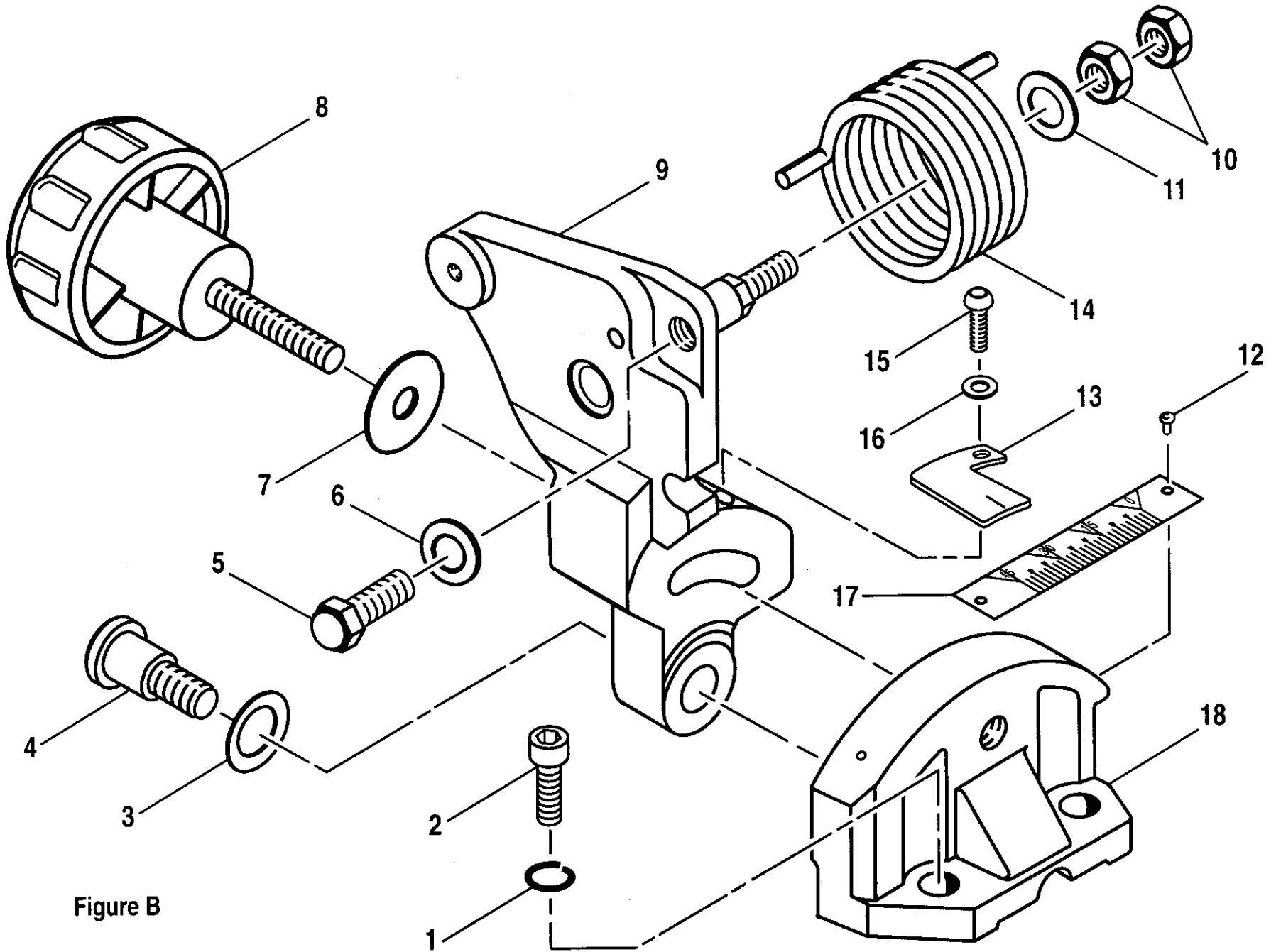

Figure B

CRAFTSMAN 18 VOLT PROFESSIONAL CORDLESS COMPOUND MITER / TRIM SAW – MODEL NUMBER 315.212180

The model number will be found on a plate attached to the motor housing. Always mention the model number in all correspondence regarding your **COMPOUND MITER / TRIM SAW** or when ordering repair parts.

PARTS LIST FOR FIGURE B

KEY NO.	PART NUMBER	DESCRIPTION	QUAN.	KEY NO.	PART NUMBER	DESCRIPTION	QUAN.
1	980116-001	Washer (M8)	2	10	6881801	Hex Nut (M12)	2
2	980117-001	Hex Hd. Bolt (M8 x 25L)	2	11	6881701	Flat Washer	1
3	589011-007	Washer	1	12	976729-001	Rivet	2
4	568206-003	Pivot Shaft	1	13	980125-001	Bevel Scale Indicator	1
5	588058-006	Lock Bolt (M10 x 20L)	1	14	568410-000	Tension Spring	1
6	980101-001	Washer (M10)	1	15	130010-401	Screw (M4 x 10L)	2
7	350308-303	Washer	1	16	980124-001	Washer	2
8	980120-001	Bevel Lock Knob	1	17	980127-001	Bevel Scale	1
9	6447001	Support Bracket	1	18	980128-001	Pivot Support	1

CRAFTSMAN 18 VOLT PROFESSIONAL CORDLESS COMPOUND MITER / TRIM SAW – MODEL NUMBER 315.212180

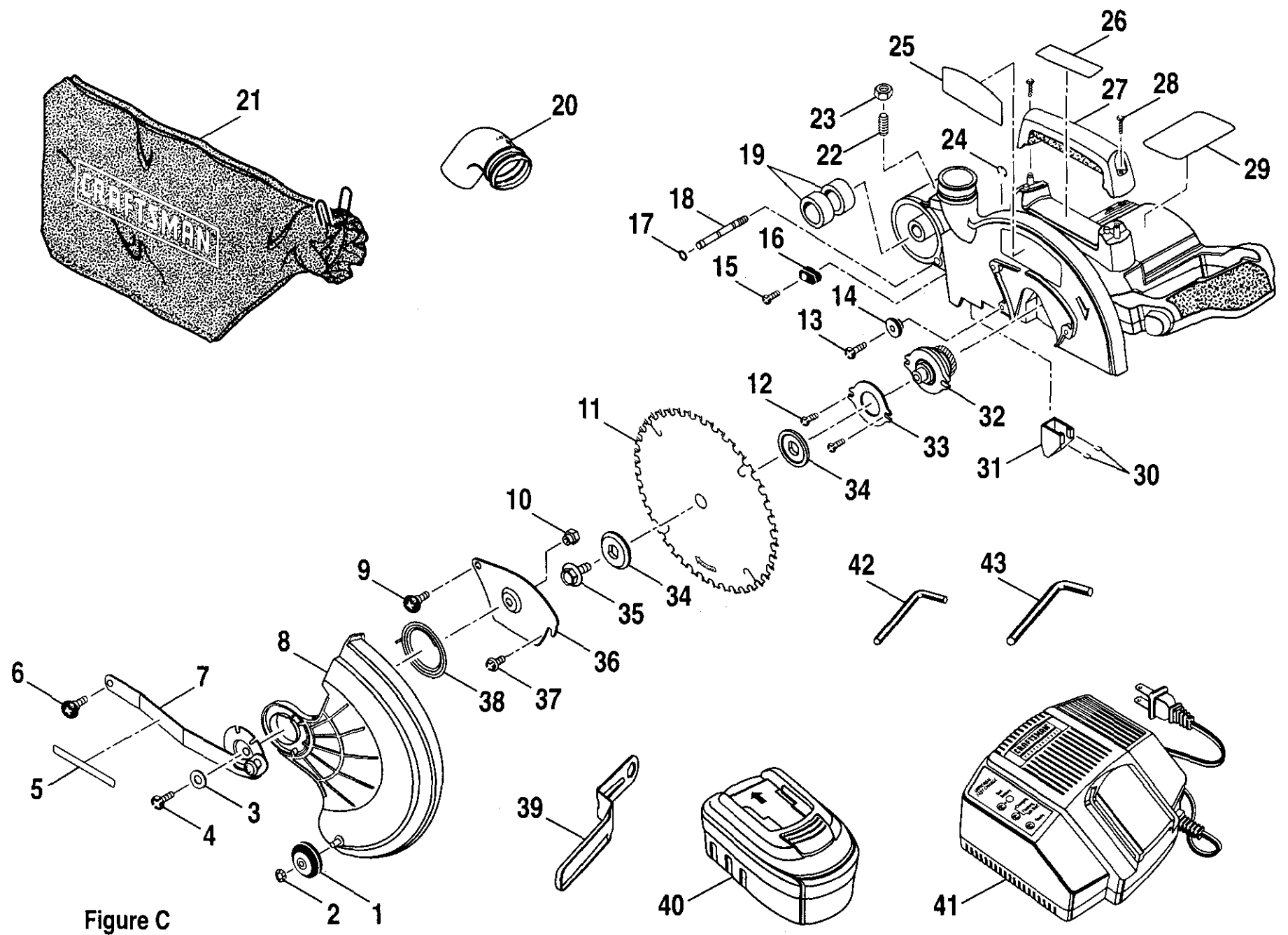

Figure C

CRAFTSMAN 18 VOLT PROFESSIONAL CORDLESS COMPOUND MITER / TRIM SAW – MODEL NUMBER 315.212180

The model number will be found on a plate attached to the motor housing. Always mention the model number in all correspondence regarding your **COMPOUND MITER / TRIM SAW** or when ordering repair parts.

PARTS LIST FOR FIGURE C

KEY NO.	PART NUMBER	DESCRIPTION	QUAN.	KEY NO.	PART NUMBER	DESCRIPTION	QUAN.
1	5541401	Guard Roller	1	23	6881901	Hex Nut (10 x 8L)	1
2	6889201	Push Nut	1	24	6881401	"E" Ring (E6)	1
3	976507-001	Washer (M5)	2	25	982661-001	Logo Plate	1
4	980091-001	Screw (M5 x 10L Pan Hd.)	1	26	9411535	Data Plate	1
5	976740-001	Label	1	27	982642-001	Carrying Handle	1
6	589015-001	Screw (M6 x 10L)	1	28	6620805	Screw (M4 x 16L)	2
7	980183-001	Blade Guard Bracket Assembly	1	29	9423007	Warning Label	1
8	5523501	Lower Blade Guard (Inc. Key Nos. 1 & 2)	1	30	6383901	"U" Clip	2
9	578406-003	Screw (M5 x 9L)	1	31	5532601	Deflector	1
10	6876501	Lock Nut (M5 x 7.8L)	1	32	982643-001	Spindle & Gear Assembly	1
11	***	Saw Blade	1	33	6379001	Bearing Plate	1
12	6621204	Screw (M4 x 16L Pan Hd.)	2	34	980098-001	Blade Washer	2
13	980172-001	Screw (M5 x 15L)	1	35	980097-001	Blade Bolt	1
14	980171-001	Stopper	1	36	980095-001	Pivot Plate	1
15	6621213	Screw (M4 x 14.5L Pan Hd.)	1	37	980100-001	Screw (M4 x 4.5L Pan Hd.)	1
16	5663301	Upper Guard Stopper	1	38	588039-002	Return Spring	1
17	6681201	"O" Ring	1	39	588082-005	Blade Wrench	1
18	6214901	Stopper Pin	1	40	* Item No. 9-11034	Battery Pack (981401-001)	1
19	5671501	Sleeve	2	41	* Item No. 9-11040	Charger (981399-001)	1
20	578502-003	Dust Guide	1	42	6887401	Hex Key (5 mm)	1
21	* Item No. 9-23436	Dust Bag (976745-001)	1	43	6887301	Hex Key (6 mm)	1
22	6617002	Hex Screw (M10 x 20L)	1		972000-841	Owner's Manual	

* Can Be Purchased At Your Nearest Sears Retail Store

*** Complete Assortment Available At Your Nearest Sears Catalog Order or Retail Store

Get it fixed, at your home or ours!

For repair of major brand appliances **in your own home...**
no matter who made it, no matter who sold it!

1-800-4-MY-HOMESM Anytime, day or night
(1-800-469-4663)

www.sears.com

To bring in products such as vacuums, lawn equipment and electronics
for repair, call for the location of your nearest **Sears Parts & Repair Center.**

1-800-488-1222 Anytime, day or night

www.sears.com

For the replacement parts, accessories and owner's manuals
that you need to do-it-yourself, call **Sears PartsDirectSM**!

1-800-366-PART 6 a.m. – 11 p.m. CST,
(1-800-366-7278) 7 days a week

www.sears.com/partsdirect

To purchase or inquire about a Sears Service Agreement:

1-800-827-6655

7 a.m. – 5 p.m. CST, Mon. – Sat

Para pedir servicio de reparación a domicilio,
y para ordenar piezas con entrega a domicilio

1-888-SU-HOGARSM
(1-888-784-6427)

Au Canada pour service en français:

1-877-LE-FOYERSM
(1-877-533-6937)

