

OPERATOR'S MANUAL

CRAFTSMAN®

10 in. TABLE SAW

Model No.
315.218061

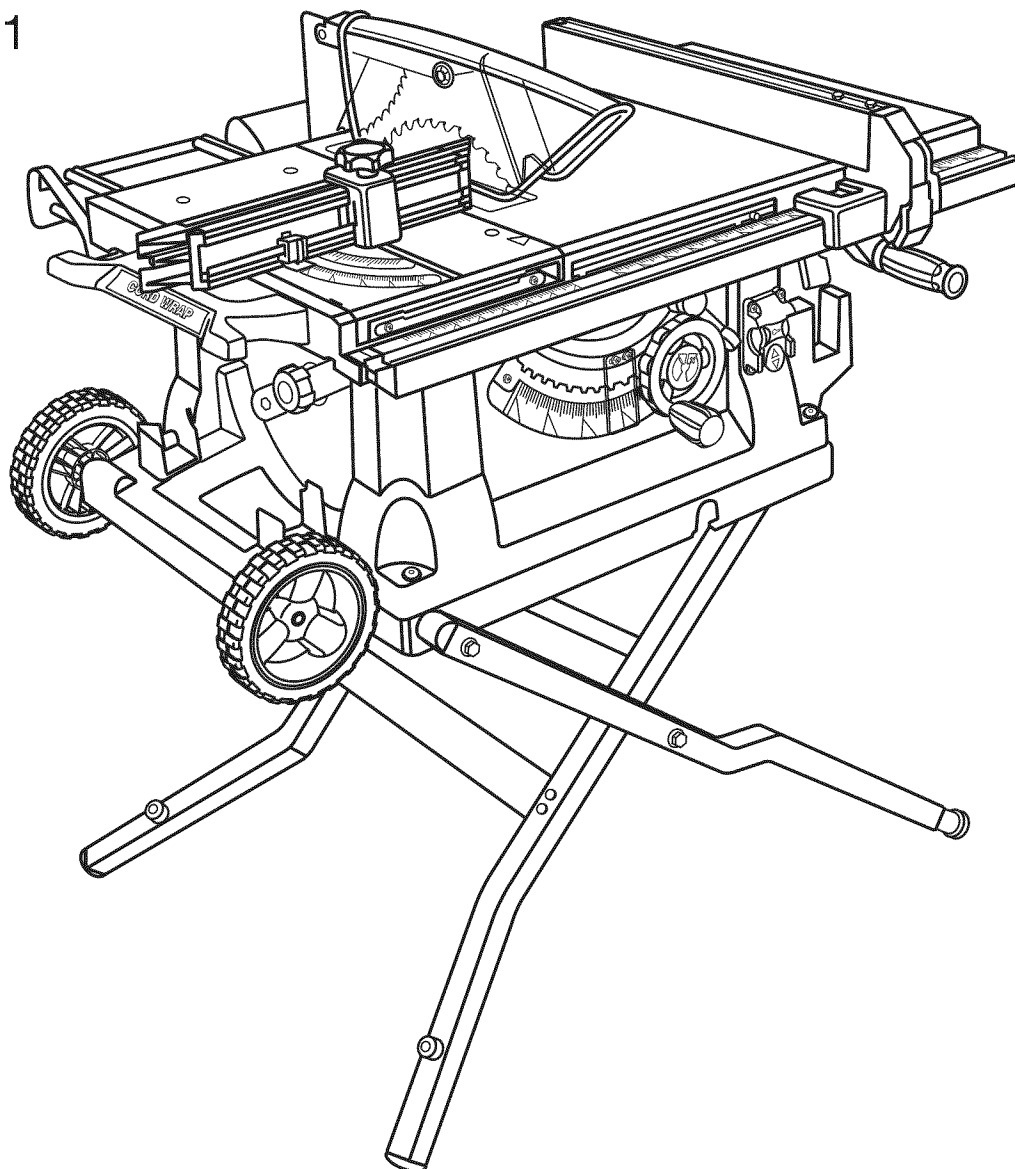

WARNING: To reduce the risk of injury, the user must read and understand the operator's manual before using this product.

Customer Help Line: 1-800-932-3188

Sears, Roebuck and Co., 3333 Beverly Rd., Hoffman Estates, IL 60179 USA
Visit the Craftsman web page: www.sears.com/craftsman

987000-585
1-7-10 (REV:04)

Save this manual for future reference



TABLE OF CONTENTS

■ Warranty	2
■ Introduction	2
■ General Safety Rules	3-4
■ Specific Safety Rules.....	4-5
■ Symbols.....	6-7
■ Electrical	8
■ Glossary of Terms.....	9
■ Features.....	10-13
■ Tools Needed	13
■ Loose Parts	14
■ Assembly	15-19
■ Operation.....	19-34
■ Adjustments.....	35-37
■ Maintenance.....	38
■ Accessories	38
■ Troubleshooting	39-40
■ Exploded View.....	41-46
■ Parts Ordering/Service	Back Page

WARRANTY

ONE YEAR FULL WARRANTY ON CRAFTSMAN TOOL

If this Craftsman tool fails due to a defect in material or workmanship within one year from the date of purchase. **Call 1-800-4-MY-HOME®** to arrange for free repair. If this tool is used for commercial or rental purposes, this warranty will apply for only ninety days from the date of purchase. This warranty applies only while this product is in the United States. This warranty gives you specific legal rights, and you may also have other rights which vary from state to state.

Sears, Roebuck and Co., Dept. 817WA, Hoffman Estates, IL 60179

INTRODUCTION

This tool has many features for making its use more pleasant and enjoyable. Safety, performance, and dependability have been given top priority in the design of this product making it easy to maintain and operate.

GENERAL SAFETY RULES

 **WARNING: Read and understand all instructions.** Failure to follow all instructions listed below, may result in electric shock, fire and/or serious personal injury.

READ ALL INSTRUCTIONS

- **KNOW YOUR POWER TOOL.** Read the operator's manual carefully. Learn the saw's applications and limitations as well as the specific potential hazards related to this tool.
- **GUARD AGAINST ELECTRICAL SHOCK BY PREVENTING BODY CONTACT WITH GROUNDED SURFACES.** For example, pipes, radiators, ranges, refrigerator enclosures.
- **KEEP GUARDS IN PLACE** and in good working order.
- **REMOVE ADJUSTING KEYS AND WRENCHES.** Form habit of checking to see that keys and adjusting wrenches are removed from tool before turning it on.
- **KEEP WORK AREA CLEAN.** Cluttered areas and benches invite accidents. **DO NOT** leave tools or pieces of wood on the saw while it is in operation.
- **DO NOT USE IN DANGEROUS ENVIRONMENTS.** Do not use power tools in damp or wet locations or expose to rain. Keep the work area well lit.
- **KEEP CHILDREN AND VISITORS AWAY.** All visitors should wear safety glasses and be kept a safe distance from work area. Do not let visitors contact tool or extension cord while operating.
- **MAKE WORKSHOP CHILDPROOF** with padlocks and master switches, or by removing starter keys.
- **DON'T FORCE TOOL.** It will do the job better and safer at the feed rate for which it was designed.
- **USE RIGHT TOOL.** Don't force the tool or attachment to do a job it was not designed for. Don't use it for a purpose not intended.
- **USE THE PROPER EXTENSION CORD.** Make sure your extension cord is in good condition. Use only a cord heavy enough to carry the current your product will draw. An undersized cord will cause a drop in line voltage resulting in loss of power and overheating. A wire gauge size (A.W.G.) of at least **14** is recommended for an extension cord 25 feet or less in length. If in doubt, use the next heavier gauge. The smaller the gauge number, the heavier the cord.
- **DRESS PROPERLY.** Do not wear loose clothing, gloves, neckties, or jewelry. They can get caught and draw you into moving parts. Rubber gloves and nonskid footwear are recommended when working outdoors. Also wear protective hair covering to contain long hair.
- **ALWAYS WEAR SAFETY GLASSES WITH SIDE SHIELDS.** Everyday eyeglasses have only impact-resistant lenses, they are **NOT** safety glasses.
- **SECURE WORK.** Use clamps or a vise to hold work when practical. It's safer than using your hand and frees both hands to operate tool.
- **DON'T OVERREACH.** Keep proper footing and balance at all times.
- **MAINTAIN TOOLS WITH CARE.** Keep tools sharp and clean for better and safer performance. Follow instructions for lubricating and changing accessories.
- **DISCONNECT TOOLS.** When not in use, before servicing, or when changing attachments, blades, bits, cutters, etc., all tools should be disconnected.
- **AVOID ACCIDENTAL STARTING.** Be sure switch is off when plugging in any tool.
- **USE RECOMMENDED ACCESSORIES.** Consult the operator's manual for recommended accessories. The use of improper accessories may risk injury.
- **NEVER STAND ON TOOL.** Serious injury could occur if the tool is tipped or if the cutting tool is unintentionally contacted.
- **CHECK DAMAGED PARTS.** Before further use of the tool, a guard or other part that is damaged should be carefully checked to determine that it will operate properly and perform its intended function. Check for alignment of moving parts, binding of moving parts, breakage of parts, mounting and any other conditions that may affect its operation. A guard or other part that is damaged must be properly repaired or replaced by an authorized service center to avoid risk of personal injury.
- **USE THE RIGHT DIRECTION OF FEED.** Feed work into a blade or cutter against the direction of rotation of blade or cutter only.
- **NEVER LEAVE TOOL RUNNING UNATTENDED. TURN THE POWER OFF.** Don't leave tool until it comes to a complete stop.
- **PROTECT YOUR LUNGS.** Wear a face or dust mask if the cutting operation is dusty.
- **PROTECT YOUR HEARING.** Wear hearing protection during extended periods of operation.
- **DO NOT ABUSE CORD.** Never yank cord to disconnect from receptacle. Keep cord from heat, oil, and sharp edges.
- **WHEN OPERATING A POWER TOOL OUTSIDE, USE AN OUTDOOR EXTENSION CORD MARKED "W-A" OR "W".** These cords are rated for outdoor use and reduce the risk of electric shock.
- **ALWAYS KEEP THE BLADE GUARD AND RIVING KNIFE/SPREADER/SPLITTER IN PLACE** and in working order.
- **KEEP BLADES CLEAN, SHARP, AND WITH SUFFICIENT SET.** Sharp blades minimize stalling and kickback.
- **KEEP HANDS AWAY FROM CUTTING AREA.** Keep hands away from blades. Do not reach underneath

GENERAL SAFETY RULES

work or around or over the blade while blade is rotating. Do not attempt to remove cut material when blade is moving.

- **BLADE COASTS AFTER BEING TURNED OFF.**
- **NEVER USE IN AN EXPLOSIVE ATMOSPHERE.** Normal sparking of the motor could ignite fumes.
- **INSPECT TOOL CORDS PERIODICALLY.** If damaged, have repaired by a qualified service technician at an authorized service facility. The conductor with insulation having an outer surface that is green with or without yellow stripes is the equipment-grounding conductor. If repair or replacement of the electric cord or plug is necessary, do not connect the equipment-grounding conductor to a live terminal. Repair or replace a damaged or worn cord immediately. Stay constantly aware of cord location and keep it well away from the rotating blade.
- **INSPECT EXTENSION CORDS PERIODICALLY** and replace if damaged.
- **GROUND ALL TOOLS.** If tool is equipped with three-prong plug, it should be plugged into a three-hole electrical receptacle.
- **CHECK WITH A QUALIFIED ELECTRICIAN** or service personnel if the grounding instructions are not completely understood or if in doubt as to whether the tool is properly grounded.
- **USE ONLY CORRECT ELECTRICAL DEVICES:** 3-wire extension cords that have 3-prong grounding plugs and 3-pole receptacles that accept the tool's plug.
- **DO NOT MODIFY** the plug provided. If it will not fit the outlet, have the proper outlet installed by a qualified electrician.
- **KEEP TOOL DRY, CLEAN, AND FREE FROM OIL AND GREASE.** Always use a clean cloth when clean-

ing. Never use brake fluids, gasoline, petroleum-based products, or any solvents to clean tool.

- **STAY ALERT AND EXERCISE CONTROL.** Watch what you are doing and use common sense. Do not operate tool when you are tired. Do not rush.
- **DO NOT USE TOOL IF SWITCH DOES NOT TURN IT ON AND OFF.** Have defective switches replaced by an authorized service center.
- **USE ONLY CORRECT BLADES.** Do not use blades with incorrect size holes. Never use blade washers or blade bolts that are defective or incorrect. The maximum blade capacity of your saw is 10 in. (254 mm).
- **BEFORE MAKING A CUT, BE SURE ALL ADJUSTMENTS ARE SECURE.**
- **BE SURE BLADE PATH IS FREE OF NAILS.** Inspect for and remove all nails from lumber before cutting.
- **NEVER TOUCH BLADE** or other moving parts during use.
- **NEVER START A TOOL WHEN ANY ROTATING COMPONENT IS IN CONTACT WITH THE WORKPIECE.**
- **DO NOT OPERATE A TOOL WHILE UNDER THE INFLUENCE OF DRUGS, ALCOHOL, OR ANY MEDICATION.**
- **WHEN SERVICING** use only identical replacement parts. Use of any other parts may create a hazard or cause product damage.
- **USE ONLY RECOMMENDED ACCESSORIES** listed in this manual or addendums. Use of accessories that are not listed may cause the risk of personal injury. Instructions for safe use of accessories are included with the accessory.
- **DOUBLE CHECK ALL SETUPS.** Make sure blade is tight and not making contact with saw or workpiece before connecting to power supply.

SPECIFIC SAFETY RULES

- **GUARD AGAINST KICKBACK.** Kickback occurs when the blade stalls rapidly and workpiece is driven back towards the operator. It can pull your hand into the blade resulting in serious personal injury. Stay out of blade path and turn switch off immediately if blade binds or stalls.
- **USE RIP FENCE.** Always use a fence or straight edge guide when ripping.
- **SUPPORT LARGE PANELS.** To minimize risk of blade pinching and kickback, always support large panels.
- **REMOVE ALL FENCES AND AUXILIARY TABLES** before transporting saw. Failure to do so can result in an accident causing possible serious personal injury.
- **ALWAYS USE BLADE GUARD, RIVING KNIFE/ SPREADER/SPLITTER, AND ANTI-KICKBACK PAWLS** on all "through-sawing" operations. Through-sawing operations are those in which the blade cuts completely through the workpiece as in ripping or cross cutting. Keep the blade guard down, the anti-kickback pawls down, and the riving knife/spreader/splitter properly aligned to the saw blade.

SPECIFIC SAFETY RULES

- **ALWAYS SECURE WORK** firmly against rip fence, miter fence, or miter gauge.
- **ALWAYS USE A PUSH STICK FOR RIPPING NARROW STOCK.** A push stick is a device used to push a workpiece through the blade instead of using your hands. Size and shape can vary but the push stick must always be narrower than the workpiece to prevent the push stick from contacting the saw blade. When ripping narrow stock, always use a push stick, so your hand does not come close to the saw blade. Use a featherboard and push blocks for non-through cuts.
- **NEVER** perform any operation “freehand” which means using only your hands to support or guide the workpiece. Always use either the rip fence or miter fence to position and guide the work.
- **NEVER** stand or have any part of your body in line with the path of the saw blade.
- **NEVER** reach behind, over, or within three inches of the blade or cutter with either hand for any reason.
- **MOVE THE RIP FENCE** out of the way when cross cutting.
- **NEVER** use rip fence as cutoff gauge when cross cutting.
- **NEVER** attempt to free a stalled saw blade without first turning the saw **OFF** and disconnecting the saw from the power source.
- **PROVIDE ADEQUATE SUPPORT** to the rear and sides of the saw table for wide or long work pieces. Use a sturdy “outrigger” support if a table extension more than 24 inches long is attached to the saw.
- **AVOID KICKBACKS** (work thrown back toward you) by:
 - a) Keeping blade sharp.
 - b) Keeping rip fence parallel to the saw blade.
 - c) Keeping riving knife/spreader/splitter, anti-kickback pawls, and blade guard in place and operating.
 - d) Not releasing the work before it is pushed all the way past the saw blade using a push stick.
 - e) Not ripping work that is twisted or warped or does not have a straight edge to guide along the fence.
- **AVOID AWKWARD OPERATIONS AND HAND POSITIONS** where a sudden slip could cause your hand to move into the cutting tool.
- **USE ONLY RECOMMENDED ACCESSORIES** listed in this manual or addendums. Use of accessories that are not listed may cause the risk of personal injury. Instructions for safe use of accessories are included with the accessory.
- **MAKE SURE THE WORK AREA HAS AMPLE LIGHTING** to see the work and that no obstructions will interfere with safe operation **BEFORE** performing any work using the table saw.
- **ALWAYS TURN OFF SAW** before disconnecting it, to avoid accidental starting when reconnecting to power supply.
- **THIS TOOL** should have the following markings:
 - a) Wear eye protection.
 - b) Use saw blade guard and riving knife/spreader/splitter for every operation for which it can be used, including all through sawing.
 - c) Keep hands out of the line of saw blade.
 - d) Use a push stick when required.
 - e) Pay particular attention to instructions on reducing risk of kickback.
 - f) Do not perform any operation freehand.
 - g) Never reach around or over the saw blade.
- **SAVE THESE INSTRUCTIONS.** Refer to them frequently and use to instruct other users. If you loan someone this tool, loan them these instructions also.







 **WARNING:** Some dust created by power sanding, sawing, grinding, drilling, and other construction activities contains chemicals known to cause cancer, birth defects or other reproductive harm. Some examples of these chemicals are:

- lead from lead-based paints,
- crystalline silica from bricks and cement and other masonry products, and
- arsenic and chromium from chemically-treated lumber.

Your risk from these exposures varies, depending on how often you do this type of work. To reduce your exposure to these chemicals: work in a well ventilated area, and work with approved safety equipment, such as those dust masks that are specially designed to filter out microscopic particles.



SYMBOLS

Some of the following symbols may be used on this tool. Please study them and learn their meaning. Proper interpretation of these symbols will allow you to operate the tool better and safer.

	Safety Alert	Indicates a potential personal injury hazard.
	Read Operator's Manual	To reduce the risk of injury, user must read and understand operator's manual before using this product.
	Eye Protection	Always wear eye protection marked to comply with ANSI Z87.1.
	No Hands Symbol	Failure to keep your hands away from the blade will result in serious personal injury.
	Wet Conditions Alert	Do not expose to rain or use in damp locations.
	Pinch Warning	Always watch for movement paying extra attention to potential areas where pinching could occur.
V	Volts	Voltage
A	Amperes	Current
Hz	Hertz	Frequency (cycles per second)
W	Watt	Power
min	Minutes	Time
~	Alternating Current	Type of current
=	Direct Current	Type or a characteristic of current
n_0	No Load Speed	Rotational speed, at no load
	Class II Construction	Double-insulated construction
.../min	Per Minute	Revolutions, strokes, surface speed, orbits etc., per minute

SYMBOLS

The following signal words and meanings are intended to explain the levels of risk associated with this product.

SYMBOL	SIGNAL	MEANING
	DANGER:	Indicates an imminently hazardous situation, which, if not avoided, will result in death or serious injury.
	WARNING:	Indicates a potentially hazardous situation, which, if not avoided, could result in death or serious injury.
	CAUTION:	Indicates a potentially hazardous situation, which, if not avoided, may result in minor or moderate injury.
	CAUTION:	(Without Safety Alert Symbol) Indicates a situation that may result in property damage.

SERVICE

Servicing requires extreme care and knowledge and should be performed only by a qualified service technician. For service we suggest you return the product to your nearest **AUTHORIZED SERVICE CENTER** for repair. When servicing, use only identical replacement parts.



WARNING: To avoid serious personal injury, do not attempt to use this product until you read thoroughly and understand completely the operator's manual. Save this operator's manual and review frequently for continuing safe operation and instructing others who may use this product.



WARNING:



The operation of any power tool can result in foreign objects being thrown into your eyes, which can result in severe eye damage. Before beginning power tool operation, always wear safety goggles or safety glasses with side shields and a full face shield when needed. We recommend Wide Vision Safety Mask for use over eyeglasses or standard safety glasses with side shields. Always use eye protection which is marked to comply with ANSI Z87.1.

SAVE THESE INSTRUCTIONS

ELECTRICAL

EXTENSION CORDS

Use only 3-wire extension cords that have 3-prong grounding plugs and 3-pole receptacles that accept the tool's plug. When using a power tool at a considerable distance from the power source, use an extension cord heavy enough to carry the current that the tool will draw. An undersized extension cord will cause a drop in line voltage, resulting in a loss of power and causing the motor to overheat. Use the chart provided below to determine the minimum wire size required in an extension cord. Only round jacketed cords listed by Underwriter's Laboratories (UL) should be used.

**Ampere rating (on tool data plate)

Cord Length	Wire Size (A.W.G.)					
	0-2.0	2.1-3.4	3.5-5.0	5.1-7.0	7.1-12.0	12.1-16.0
25'	16	16	16	16	14	14
50'	16	16	16	14	14	12
100'	16	16	14	12	10	—

**Used on 12 gauge - 20 amp circuit.

NOTE: AWG = American Wire Gauge

When working with the tool outdoors, use an extension cord that is designed for outside use. This is indicated by the letters "WA" or "W" on the cord's jacket.

Before using an extension cord, inspect it for loose or exposed wires and cut or worn insulation.

⚠ WARNING: Keep the extension cord clear of the working area. Position the cord so that it will not get caught on lumber, tools or other obstructions while you are working with a power tool. Failure to do so can result in serious personal injury.

⚠ WARNING: Check extension cords before each use. If damaged replace immediately. Never use tool with a damaged cord since touching the damaged area could cause electrical shock resulting in serious injury.

ELECTRICAL CONNECTION

This tool is powered by a precision built electric motor. It should be connected to a **power supply that is 120 volts, AC only (normal household current), 60 Hz**. Do not operate this tool on direct current (DC). A substantial voltage drop will cause a loss of power and the motor will overheat. If the saw does not operate when plugged into an outlet, double check the power supply.

SPEED AND WIRING

The no-load speed of this tool is approximately 5,000 r/min. (RPM). This speed is not constant and decreases under a load or with lower voltage. For voltage, the wiring in a shop is as important as the motor's horsepower rating. A line intended only for lights cannot properly carry a power tool motor. Wire that is heavy enough for a short distance will be too light for a greater distance. A line that can support one power tool may not be able to support two or three tools.

GROUNDING INSTRUCTIONS

In the event of a malfunction or breakdown, grounding provides a path of least resistance for electric current to reduce the risk of electric shock. This tool is equipped with an electric cord having an equipment-grounding conductor and a grounding plug. The plug must be plugged into a matching outlet that is properly installed and grounded in accordance with all local codes and ordinances.

Do not modify the plug provided. If it will not fit the outlet, have the proper outlet installed by a qualified electrician.

⚠ WARNING: Improper installation of the grounding plug can result in a risk of electric shock. When repair or replacement of the cord is required, do not connect the grounding wire to either flat blade terminal. The wire with insulation having an outer surface that is green with or without yellow stripes is the grounding wire.

Check with a qualified electrician or service personnel if the grounding instructions are not completely understood, or if in doubt as to whether the tool is properly grounded.

Repair or replace a damaged or worn cord immediately.

This tool is intended for use on a circuit that has an outlet like the one shown in figure 1. It also has a grounding pin like the one shown.

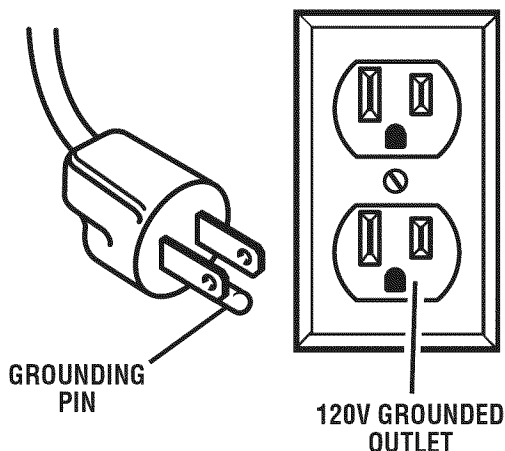

Fig. 1

GLOSSARY OF TERMS

Anti-Kickback Pawls (radial arm and table saws)

A device which, when properly installed and maintained, is designed to stop the workpiece from being kicked back toward the front of the saw during a ripping operation.

Arbor

The shaft on which a blade or cutting tool is mounted.

Bevel Cut

A cutting operation made with the blade at any angle other than 90° to the table surface.

Chamfer

A cut removing a wedge from a block so the end (or part of the end) is angled rather than at 90°.

Compound Cut

A cross cut made with both a miter and a bevel angle.

Cross Cut

A cutting or shaping operation made across the grain or the width of the workpiece.

Cutter Head (planers and jointers)

A rotating piece of adjustable blades. The cutter head removes material from the workpiece.

Dado Cut

A non-through cut which produces a square-sided notch or trough in the workpiece (requires a special blade).

Featherboard

A device used to help control the workpiece by guiding it securely against the table or fence during any ripping operation.

FPM or SPM

Feet per minute (or strokes per minute), used in reference to blade movement.

Freehand

Performing a cut without the workpiece being guided by a fence, miter gauge, or other aids.

Gum

A sticky, sap-based residue from wood products.

Heel

Alignment of the blade to the fence.

Kerf

The material removed by the blade in a through cut or the slot produced by the blade in a non-through or partial cut.

Kickback

A hazard that can occur when the blade binds or stalls, throwing the workpiece back toward operator.

Leading End

The end of the workpiece pushed into the tool first.

Miter Cut

A cutting operation made with the workpiece at any angle to the blade other than 90°.

Non-Through Cuts

Any cutting operation where the blade does not extend completely through the thickness of the workpiece.

Pilot Hole (drill presses)

A small hole drilled in a workpiece that serves as a guide for drilling large holes accurately.

Push Blocks and Push Sticks

Devices used to feed the workpiece through the saw blade during cutting operations. A push stick (not a push block) should be used for narrow ripping operations.

These aids help keep the operator's hands well away from the blade.

Resaw

A cutting operation to reduce the thickness of the workpiece to make thinner pieces.

Resin

A sticky, sap-based substance that has hardened.

Revolutions Per Minute (RPM)

The number of turns completed by a spinning object in one minute.

Ripping or Rip Cut

A cutting operation along the length of the workpiece.

Riving Knife/Spreader/Splitter (table saws)

A metal piece, slightly thinner than the blade, which helps keep the kerf open and also helps to prevent kickback.

Saw Blade Path

The area over, under, behind, or in front of the blade. As it applies to the workpiece, that area which will be or has been cut by the blade.

Set

The distance that the tip of the saw blade tooth is bent (or set) outward from the face of the blade.

Snipe (planers)

Depression made at either end of a workpiece by cutter blades when the workpiece is not properly supported.

Through Sawing

Any cutting operation where the blade extends completely through the thickness of the workpiece.

Throw-Back

The throwing back of a workpiece usually caused by the workpiece being dropped into the blade or being placed inadvertently in contact with the blade.

Workpiece or Material

The item on which the operation is being done.

Worktable

Surface where the workpiece rests while performing a cutting, drilling, planing, or sanding operation.

FEATURES

PRODUCT SPECIFICATIONS

Blade Arbor	5/8 in.	Rating	120 V, AC only, 60 Hz
Blade Diameter	10 in.	Input	15 Amps.
Blade Tilt	0° - 45°	No Load Speed	5,000 r/min. (RPM)
Net Weight without Leg Stand	61.5 lbs.	Cutting Depth at 0°:	3-1/2 in.
Net Weight with Leg Stand	82.5 lbs.	Cutting Depth at 45°:	2-1/2 in.

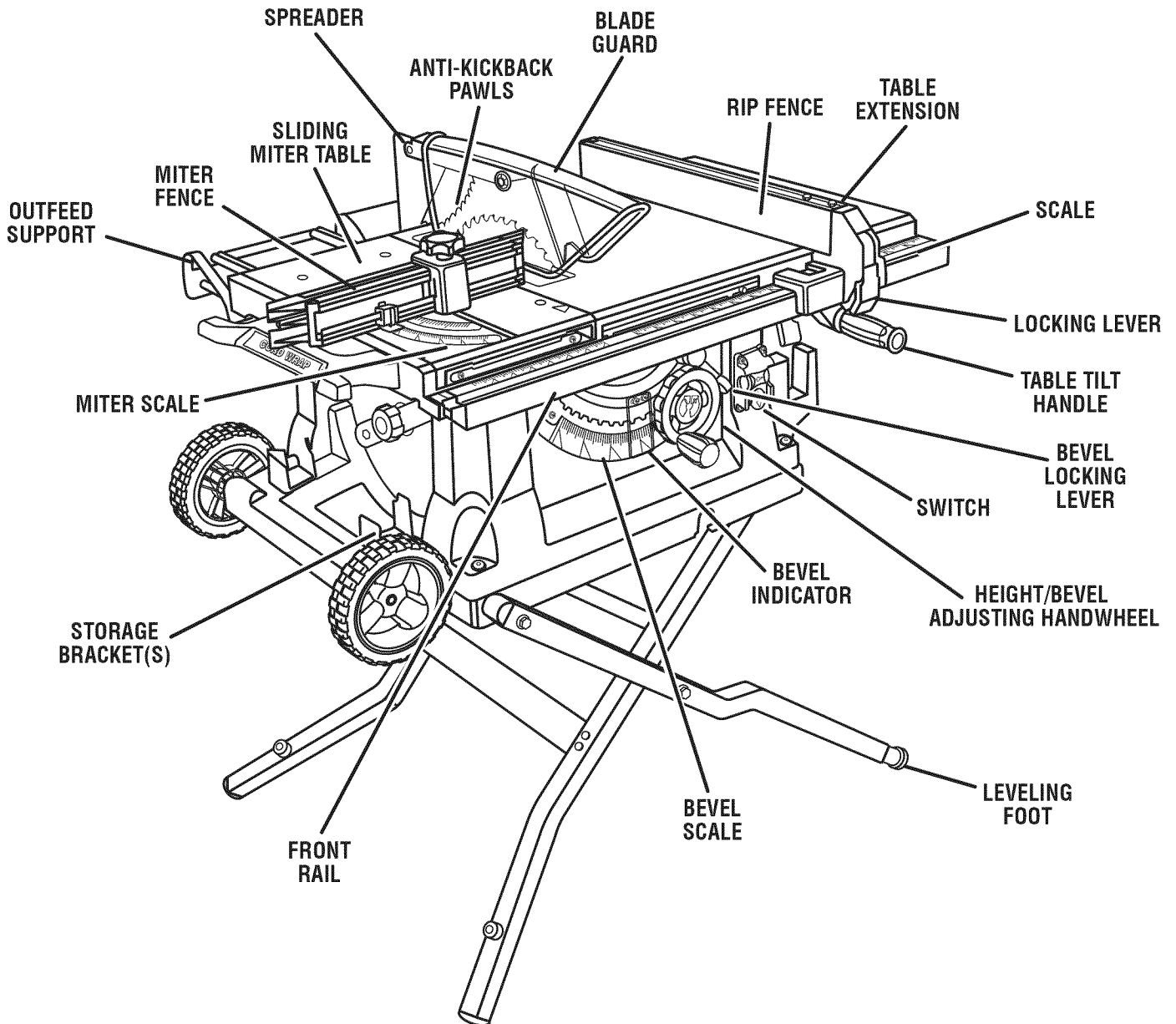

Fig. 2

FEATURES

KNOW YOUR TABLE SAW

See Figure 2.

The safe use of this product requires an understanding of the information on the tool and in this operator's manual as well as a knowledge of the project you are attempting. Before use of this product, familiarize yourself with all operating features and safety rules.

ADJUSTING CLAMP - This clamp locks the miter fence at the desired cutting angle.

ANTI-KICKBACK PAWLS - Kickback is a hazard in which the workpiece is thrown back toward the operator. The teeth on the anti-kickback pawls point away from the workpiece. If the workpiece should be pulled back toward the operator, the teeth dig into the wood to help prevent or reduce the possibility of kickback.

BEVEL SCALE - The easy-to-read scale on the front of the cabinet shows the exact blade angle.

BLADE - This saw is provided with a 36-tooth, 10 in. carbide blade. The blade is raised and lowered with the height/bevel adjusting handwheel. Bevel angles are locked with the bevel locking lever.

 **WARNING:** Do not use blades rated less than the speed of this tool. Failure to heed this warning could result in personal injury.

BLADE GUARD - Always keep the blade guard down over the saw blade for through-sawing cuts.

BEVEL LOCKING LEVER - This lever, placed just under the saw table surface on the front of the cabinet, locks the angle setting of the blade.

HEIGHT/BEVEL ADJUSTING HANDWHEEL - Located on the front of the cabinet, use this handwheel to lower and raise the blade for height adjustments or blade replacement. This handwheel also makes the adjustment for bevel angles easy.

LEG STAND - Attached to the table saw base, the leg stand opens and closes with ease.

MITER FENCE WITH ADJUSTING CLAMP KNOB - The fence attaches to the sliding miter table and can be angled for miter and compound miter cuts as well as straight cuts such as cross cuts and bevel cross cuts. With the locator pin in place, this knob locks the miter fence to the sliding miter table at the desired cutting angle.

MOTOR - The powerful induction motor, with capacitor start and V-belt drive, is housed in a sturdy steel base.

RIP FENCE - A sturdy metal fence guides the workpiece and is secured with the locking lever. Grooves run along the top and sides of the rip fence for use with optional clamps and accessories.

SCALE - Located on the front rail, the easy-to-read scale provides precise measurements for rip cuts.

SLIDING MITER TABLE - The sliding miter table moves allowing the operator to slide the workpiece across the saw table.

SLIDING TABLE EXTENSIONS - Located on the left side of the saw table, this table extension gives the operator additional support when cutting wide workpieces.

SPREADER - A metal piece of the blade guard assembly, slightly thinner than the saw blade, which helps keep the kerf open and prevent kickback.

SWITCH ASSEMBLY - This saw has an easy access power switch located below the front rail. To lock the switch in the off position, remove the switch key from the switch. Place the key in a location that is inaccessible to children and others not qualified to use the tool.

FEATURES

OPERATING COMPONENTS

The upper portion of the blade projects up through the table and is surrounded by an insert called the throat plate. The height of the blade is set with a handwheel on the front of the cabinet. To accommodate wide panels, the saw table has rails on each side. Detailed instructions are provided in the *Operation* section of this manual for the basic cuts: cross cuts, miter cuts, bevel cuts, and compound cuts.

The sliding miter table assembly is used for cross cutting operations. The miter fence is easily adjusted to cut wood at an angle by loosening the adjusting clamp, setting the fence to the miter scale, and retightening the clamp. The sliding miter table, which rests on a base mounted on the rails, can be repositioned along the rails for wide work. It can be reversed so the projecting base is in the back and can be moved from the left side to the right side as needed. With the miter fence removed, the miter table offers additional support for other operations such as ripping.

The rip fence is used to position work for lengthwise cuts. A scale on the front rail shows the distance between the rip fence and the blade.

It is very important to use the blade guard assembly for all through-sawing operations. The blade guard assembly includes: riving knife/spreader/splitter, anti-kickback pawls, and plastic blade guard.

POWER SWITCH

See Figure 3.

This saw is equipped with a power switch that has a built-in locking feature. This feature is intended to prevent unauthorized and possible hazardous use by children and others.

TO TURN YOUR SAW ON:

- With the switch key inserted into the switch, lift the switch button to turn on (I).

TO TURN YOUR SAW OFF:

- Press the switch button down to turn off (O).

TO LOCK YOUR SAW:

- Press the switch button down.
- Remove the switch key from the switch and store in a safe, secure location.

⚠ WARNING: ALWAYS remove the switch key when the tool is not in use and keep it in a safe place. In the event of a power failure, turn the switch off (O) and remove the key. This action will prevent the tool from accidentally starting when power returns.

⚠ WARNING: ALWAYS make sure your workpiece is not in contact with the blade before operating the switch to start the tool. Failure to heed this warning may cause the workpiece to be kicked back toward the operator and result in serious personal injury.

⚠ WARNING: To reduce the risk of accidental starting, ALWAYS make sure the switch is in the off (O) position before plugging tool into the power source.

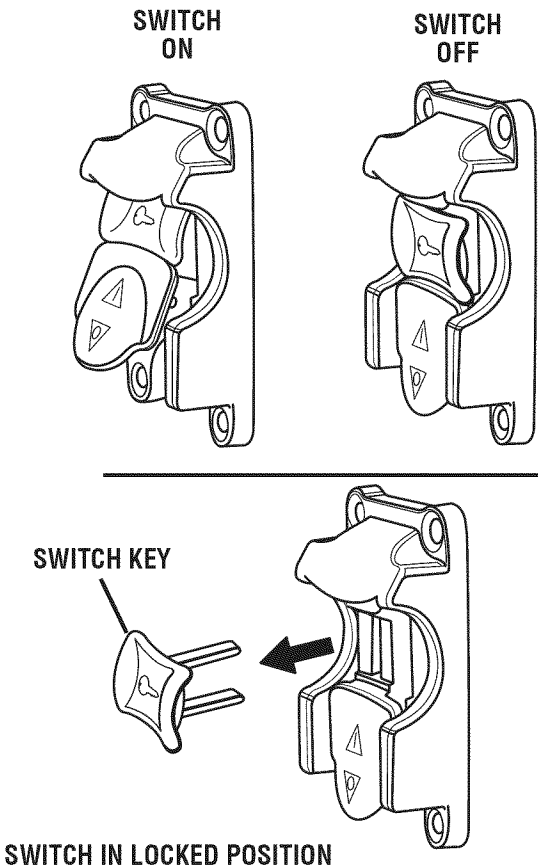

Fig. 3

FEATURES

BLADES

For maximum performance, it is recommended that you use the Craftsman 36-tooth, 10 in. carbide combination blade provided with your saw. Additional blade styles of the same high quality are available for specific operations such as ripping. Your local dealer can provide you with complete information.

⚠ WARNING: Do not use blades rated less than the speed of this tool. Failure to heed this warning could result in personal injury.

TOOLS NEEDED

The following tools (not included or drawn to scale) are needed for assembly and alignment:

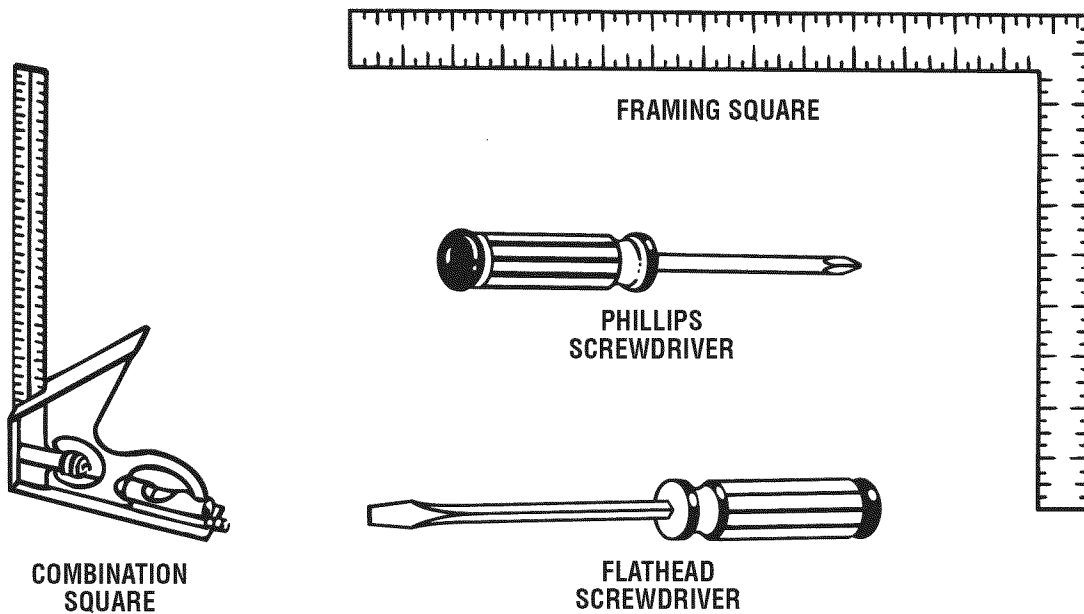

Fig. 4

LOOSE PARTS

The following items are included with your table saw:

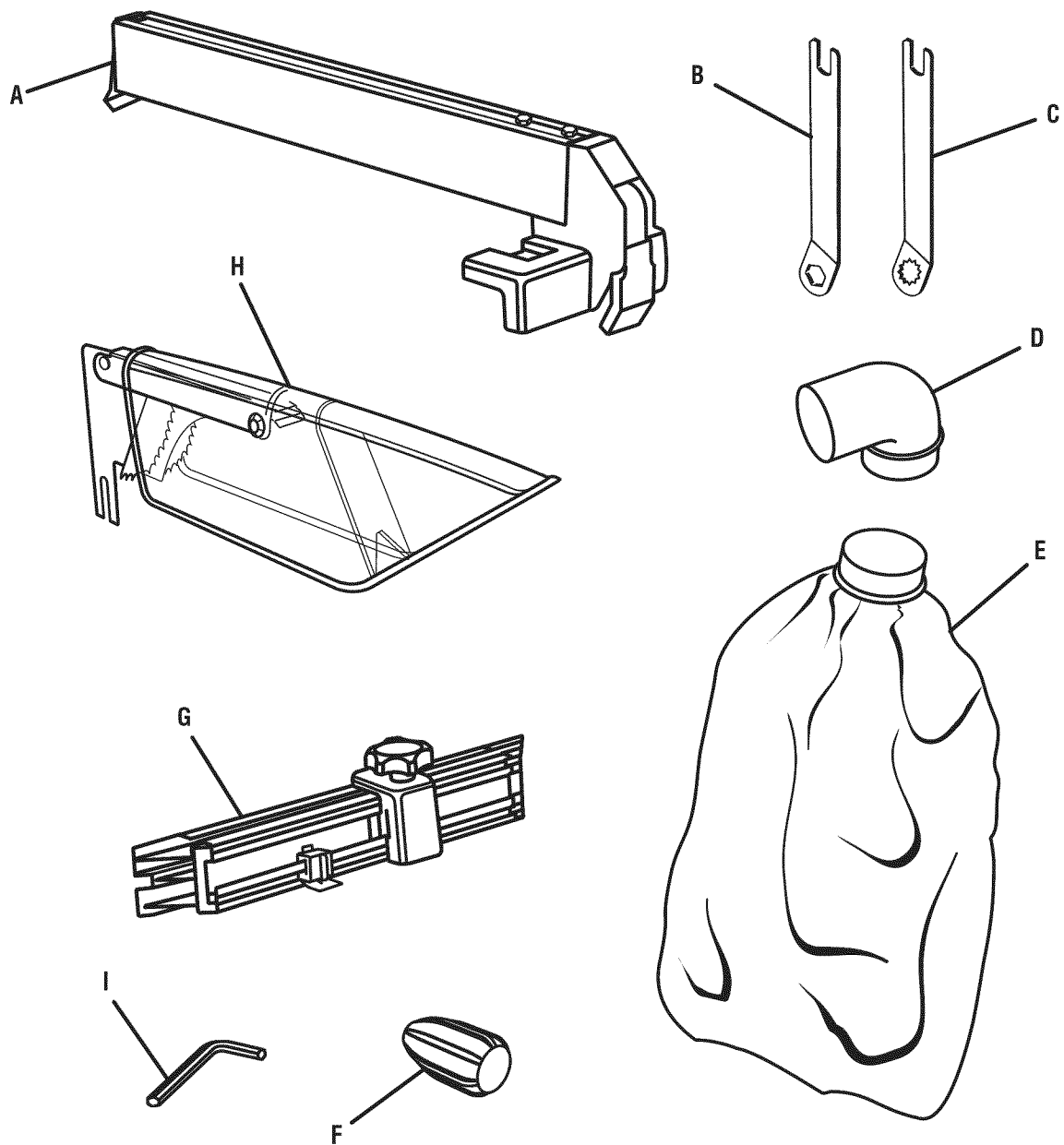

Fig. 5

A. Rip Fence	1
B. Large Blade Wrench	1
C. Small Blade Wrench	1
D. Elbow	1
E. Dust Bag	1
F. Bevel Handle Assembly	1
G. Miter Fence with Miter Fence Holder and Adjusting Clamp Knob	1
H. Blade Guard with Spreader and Anti-Kickback Pawls	1
I. Hex Key	1

ASSEMBLY

UNPACKING

This product requires assembly.

- Carefully lift saw from the carton and place it on a level work surface.

NOTE: This tool is heavy. To avoid back injury, keep your knees bent and lift with your legs, not your back, and get help when needed.

- ⚠ **WARNING:** Do not use this product if any parts on the Loose Parts List are already assembled to your product when you unpack it. Parts on this list are not assembled to the product by the manufacturer and require customer installation. Use of a product that may have been improperly assembled could result in serious personal injury.

- Inspect the tool carefully to make sure no breakage or damage occurred during shipping.
- Do not discard the packing material until you have carefully inspected and satisfactorily operated the tool.

NOTE: Remove the foam block from between the saw's housing and the motor by first beveling the blade (see page 23).

- The saw is factory set for accurate cutting. After assembling it, check for accuracy. If shipping has influenced the settings, refer to specific procedures explained in this manual.
- If any parts are damaged or missing, please call 1-800-932-3188 for assistance.

- ⚠ **WARNING:** If any parts are damaged or missing, do not operate this tool until the missing parts are replaced. Use of this product with damaged or missing parts could result in serious personal injury.

- ⚠ **WARNING:** Do not attempt to modify this tool or create accessories not recommended for use with this tool. Any such alteration or modification is misuse and could result in a hazardous condition leading to possible serious personal injury.

- ⚠ **WARNING:** Do not connect to power supply until assembly is complete. Failure to comply could result in accidental starting and possible serious personal injury.

- ⚠ **WARNING:** Do not lift the saw without help. Hold it close to your body. Keep your knees bent and lift with your legs, not your back. Ignoring these precautions can result in back injury.

- ⚠ **WARNING:** Never stand directly in line with the blade or allow hands to come closer than 3 in. to the blade. Do not reach over or across the blade. Failure to heed this warning can result in serious personal injury.

- ⚠ **WARNING:** To avoid serious personal injury, always make sure the table saw is securely mounted to a workbench or an approved leg stand. NEVER operate the saw on the floor.

MOUNTING HOLES

This tool comes mounted to a leg stand. If you chose to remove the leg stand, the table saw must be mounted to a firm supporting surface such as a workbench or leg stand. Four bolt holes have been provided in the saw's base for this purpose. Each of the four mounting holes should be bolted securely using 3/8 in. machine bolts, lock washers, and hex nuts (not included). Bolts should be of sufficient length to accommodate the saw base, lock washers, hex nuts, and the thickness of the workbench. Tighten all four bolts securely.

Carefully check the workbench after mounting to make sure that no movement can occur during use. If any tipping, sliding, or walking is noted, secure the workbench to the floor before operating.

TO INSTALL THE BEVEL HANDLE ASSEMBLY

See Figure 6.

- Lift the end cap off the bevel handle assembly using a flat blade screwdriver.
- Hold the nylon nut securely and turn the screw counter-clockwise to remove the nut completely.

NOTE: Do not remove the screw from the handle or the washer from the end of the screw.

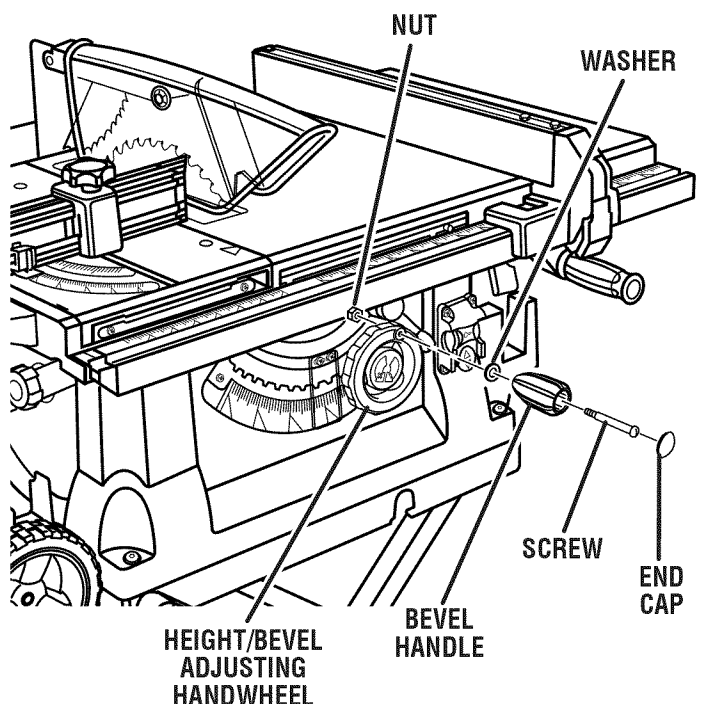

Fig. 6

ASSEMBLY

- Place the nylon nut into the recessed hole on the back of the height/bevel adjusting handwheel and hold in place.
- Slide the handle, screw, and washer into the hole on the height/bevel adjusting handwheel.
- Using a flathead screwdriver, turn the screw clockwise and tighten in place.
- Push the end cap back in place on the end of the handle.

TO OPEN/CLOSE (SET-UP/TEAR DOWN) THE LEG STAND

See Figure 7.

To open (set-up) the leg stand:

- **Step 1:** With the saw table on end and standing to the side, use your left hand to pull the leg stand latch towards you.
- **Step 2:** Once the leg stand is released from the table saw base, ease the legs of the stand down.
- **Step 3:** Grasp the upper leg support below the saw cabinet.
- **Step 4:** Keeping your left hand clear of the leg stand, pull the leg stand up until it locks into place.
- **Step 5:** With the left hand firmly on the table tilt handle, grasp the leg stand with your right hand.
- **Steps 6 and 7:** Push the leg stand towards the ground with your right hand and pull in the same direction with your left hand until the table saw is in an upright position.

To close (tear down) the leg stand:

- **Step 1:** Standing to the side of the table saw, grasp the table tilt handle with your left hand.
- **Step 2:** Tilt the table saw to your left and grab the leg just below the leveling foot.
- **Step 3:** Lower the saw to the floor until it is balanced on end.
- **Step 4:** Using your left hand, release the leg stand latch.
- **Steps 5 and 6:** Once the leg stand is released from the table saw base, ease the legs of the leg stand toward the floor.
- **Step 7:** Lift the lower leg of the leg stand until it locks in place.

TO SECURE/LEVEL THE SAW

With the leg stand open and the table saw resting on a flat, level surface, the saw should not move or rock from side to side. If the saw rocks from side to side, the leveling foot needs adjusting until the leg stand is balanced.

- Turning clockwise will lower the foot.
- Turning counterclockwise will raise the foot.

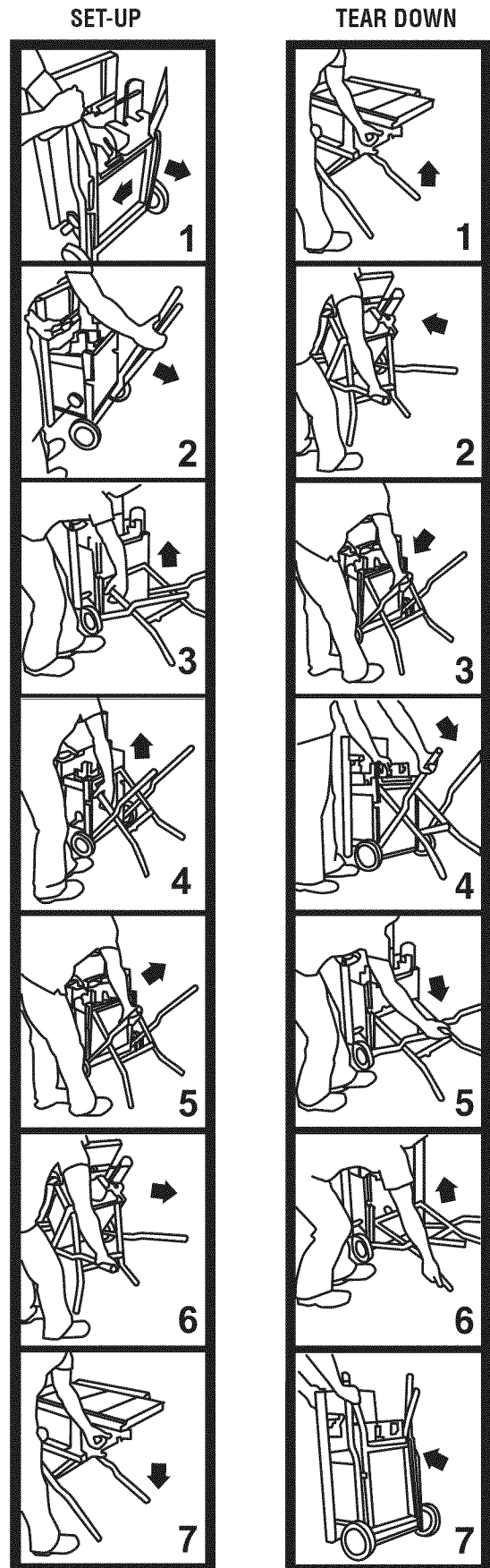

Fig. 7

ASSEMBLY

TO STORE THE TABLE SAW ACCESSORIES

See Figures 8 - 9.

The table saw has two convenient storage areas (one on either side of the saw cabinet) specifically designed for the saw's accessories.

When not in use, store the accessories securely by snapping each accessory in place.

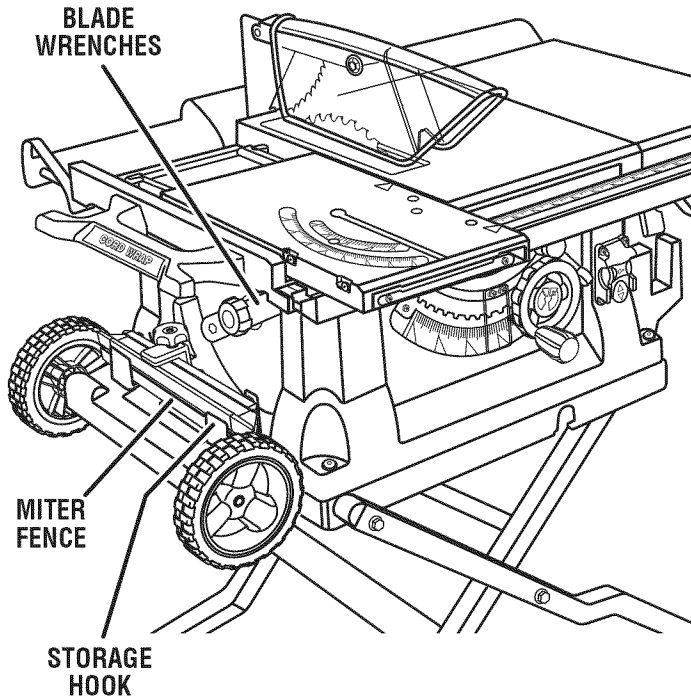

Fig. 8

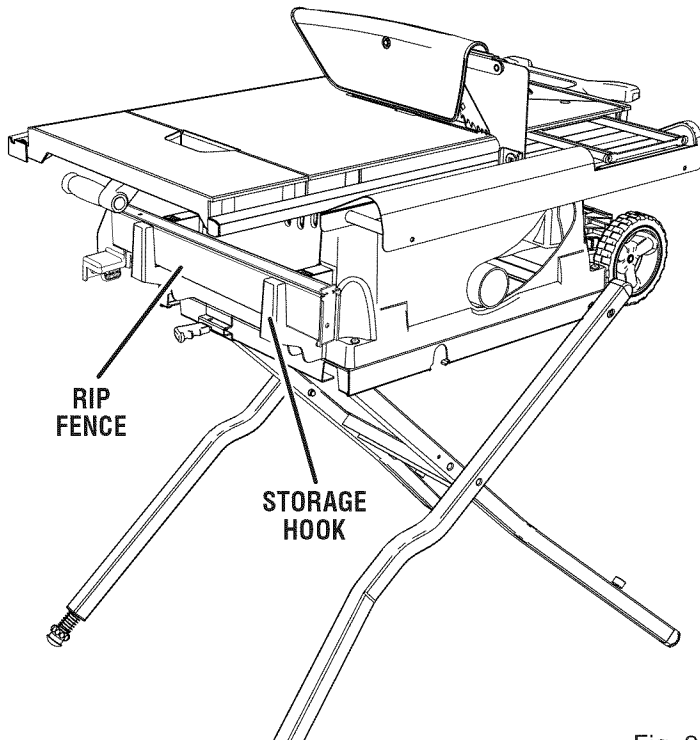

Fig. 9

TO MOVE THE LEG STAND

See Figure 10.

To move the leg stand:

- Holding the leg stand firmly, pull the leg stand toward you until the leg stand and saw are balanced on the wheels.
- Push the saw to the desired location then either open the leg stand for immediate saw operation or store the saw in a dry environment.

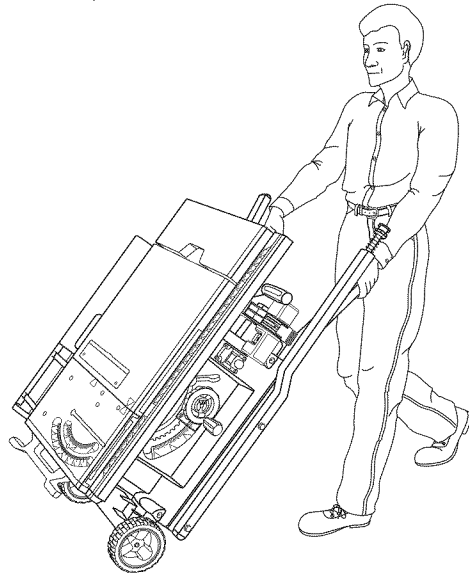

Fig. 10

TO REMOVE/REPLACE THE THROAT PLATE

See Figure 11.

- Lower the blade by turning the height/bevel adjusting handwheel counterclockwise.
- Loosen the screws in the throat plate.
- Lift the throat plate from the saw.
- To reinstall the throat plate, align the holes in the throat plate with the holes in the saw table.
- Retighten the screws, being careful not to overtighten, which can cause the throat plate to bow or bend.

NOTE: Securely tighten throat plate screws. Do not allow the throat plate to bow up above the table surface.

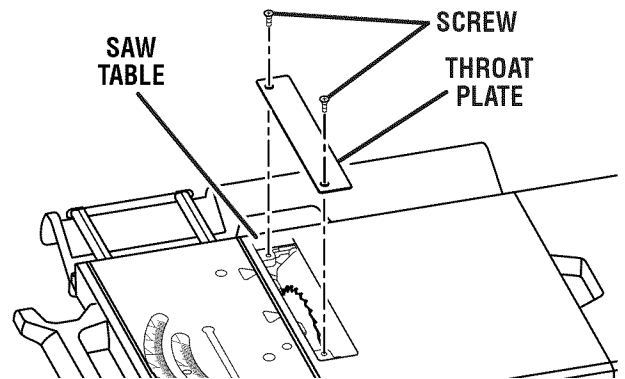

Fig. 11

ASSEMBLY

TO CHECK SAW BLADE INSTALLATION

See Figure 12.

CAUTION: To work properly, the saw blade teeth must point down toward the front of the saw. Failure to do so could cause damage to the saw blade, the saw, or the workpiece.

NOTE: Arbor shaft has left hand threads.

- Lower the saw blade and remove the throat plate.
- Make sure the bevel locking lever is securely pushed to the left. Raise the saw blade to its full height by turning the height/bevel adjusting handwheel clockwise.

To loosen the blade:

- Using the smaller blade wrench, place the flat open end on the flats on the arbor shaft.
- Insert the closed end of the larger blade wrench over the hex nut. Holding both wrenches firmly, pull the larger wrench forward to the front of the machine.

To tighten the blade:

- Using the smaller blade wrench, place the flat open end into the flats on the arbor shaft.
- Insert the closed end of the larger blade wrench over the hex nut. Holding both wrenches firmly, push the larger wrench to the back of the machine. Make sure the blade nut is securely tightened. Do not overtighten.
- Reinstall the throat plate.
- Check all clearances for free blade rotation.

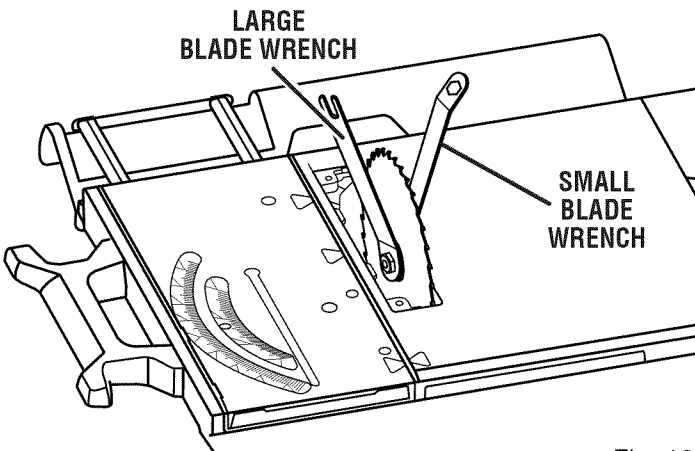

Fig. 12

TO INSTALL MITER FENCE

See Figure 13.

- Remove the miter fence from the miter fence storage on the side of the saw cabinet.
- To install the miter fence to the sliding miter table, loosen the adjusting clamp knob so the bolt has enough clearance to slide into the table slot.

NOTE: If the miter fence holder is not installed, slide the tabs into the grooves in the miter fence.

- Mount the miter fence to the miter table by installing the locator pin (below the miter fence) into holes "A" or "B". At the same time, place the attachment bolt in the slot.
- Properly adjust the miter indicator to the scale on the end of the fence opposite the locator pin.
- Retighten the adjusting clamp knob.

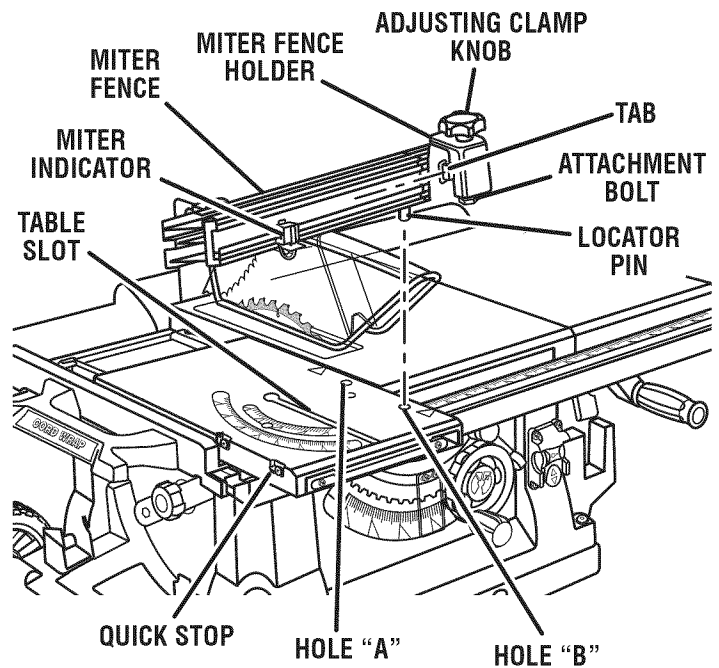

Fig. 13

ASSEMBLY

TO INSTALL BLADE GUARD ASSEMBLY

See Figure 14.

Proper installation of the blade guard assembly means that the saw blade and spreader are in alignment. ALWAYS align the spreader to the saw blade prior to turning on the table saw.

- Lower the blade.
- Loosen the wing nut and slide the spreader between the mounting plate and flat washer. Partially retighten the wing nut.
- Check the blade and spreader alignment.

NOTE: Blade alignment with the spreader can be adjusted for different blade widths. Refer to: **To Check, and Align the Spreader, Saw Blade, and Blade Guard Assembly** in the *Adjustment* section. Check the blade guard assembly for clearances and free movement.

- Tighten wing nut securely.

NOTE: If the wing nut and washers are completely removed, reinstall in the following order: flat washer, star washer, and wing nut.

TO INSTALL DUST BAG

See Figure 15.

- Slide the elbow inside the dust chute on the back of the table saw.
- Slide the dust bag into the elbow.

NOTE: For efficient operation, empty the dust bag before it is half full. This will permit better air flow through the bag.

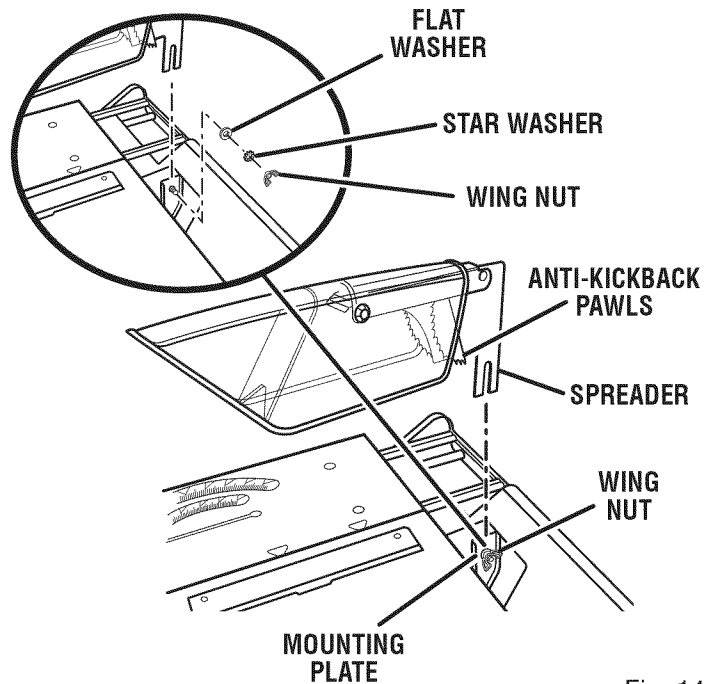

Fig. 14

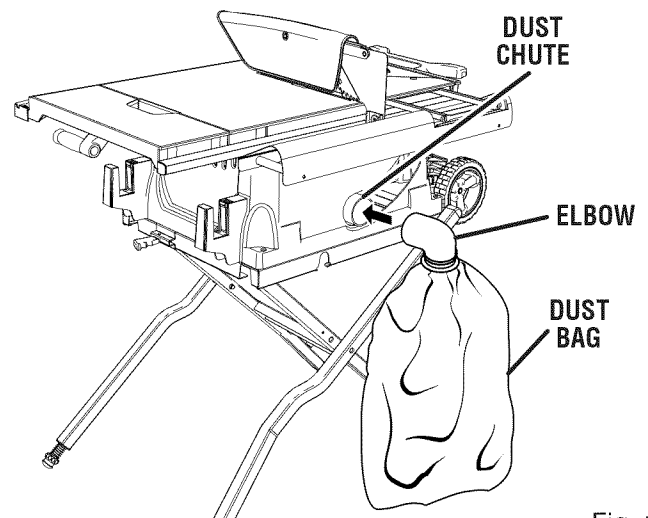

Fig. 15

OPERATION

WARNING: Do not allow familiarity with tools to make you careless. Remember that a careless fraction of a second is sufficient to inflict severe injury.

WARNING: Always wear eye protection with side shields marked to comply with ANSI Z87.1. Failure to do so could result in objects being thrown into your eyes, resulting in possible serious injury.

WARNING: Do not use any attachments or accessories not recommended by the manufacturer of this tool. The use of attachments or accessories not recommended can result in serious personal injury.

WARNING: Although many of the illustrations in this manual are shown with the blade guard removed for clarity, do not operate the saw without the blade guard unless specifically instructed to do so.

OPERATION

APPLICATIONS

You may use this tool for the purposes listed below:

- Straight line cutting operations such as cross cutting, ripping, mitering, beveling, and compound cutting
- Dado or molding cuts with optional accessories
- Cabinet making and woodworking

NOTE: This table saw is designed to cut wood and wood composition products only.

BASIC OPERATION OF THE TABLE SAW

The 3-prong plug must be plugged into a matching outlet that is properly installed and grounded according to all local codes and ordinances. Improper connection of the equipment can result in electric shock. Do not modify the plug if it will not fit the outlet. Have the correct outlet installed by a qualified electrician. Refer to the *Electrical* section in this manual.

CAUSES OF KICKBACK

Kickback can occur when the blade stalls or binds, kicking the workpiece back toward you with great force and speed. If your hands are near the saw blade, they may be jerked loose from the workpiece and may contact the blade. Kickback can cause serious injury. Use precautions to avoid the risks.

Kickback can be caused by any action that pinches the blade in the wood such as:

- Making a cut with incorrect blade depth
- Sawing into knots or nails in the workpiece
- Twisting the wood while making a cut
- Failing to support work
- Forcing a cut
- Cutting warped or wet lumber
- Using the wrong blade for the type of cut
- Not following correct operating procedures
- Misusing the saw
- Failing to use the anti-kickback pawls
- Cutting with a dull, gummed-up, or improperly set blade

AVOIDING KICKBACK

- Always use the correct blade depth setting. The top of the blade teeth should clear the workpiece by 1/8 in. to 1/4 in.
- Inspect the work for knots or nails before beginning a cut. Knock out any loose knots with a hammer. Never saw into a loose knot or nail.

- Always use the rip fence when rip cutting and the miter fence when cross cutting. This helps prevent twisting the wood in the cut.
- Always use clean, sharp, and properly-set blades. Never make cuts with dull blades.
- To avoid pinching the blade, support the work properly before beginning a cut.
- When making a cut, use steady, even pressure. Never force cuts.
- Do not cut wet or warped lumber.
- Always hold your workpiece firmly with both hands or with push sticks. Keep your body in a balanced position to be ready to resist kickback should it occur. Never stand directly in line with the blade.
- Use the right type of blade for the cut being made.

CUTTING AIDS

See Figure 16.

Push sticks are devices used for safely pushing a workpiece through the blade. They can be made in various sizes and shapes from scrap wood and used in a specific project. The stick must be narrower than the workpiece, with a 90° notch in one end and shaping for a grip on the other end.

A push block has a handle fastened by recessed screws from the underside. Use it on non-through cuts.

CAUTION: Be sure the screws in a push block are recessed to avoid damaging the saw or workpiece.

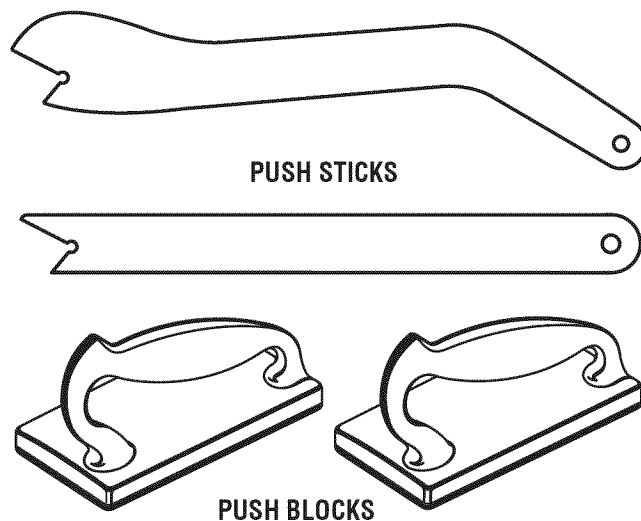

Fig. 16

OPERATION

FEATHERBOARD

A featherboard is a device used to help control the workpiece by guiding it securely against the table or fence. Featherboards are especially useful when ripping small workpieces and for completing non-through cuts. The end is angled with a number of short kerfs to give a friction hold on the workpiece and locked in place on the table with a C-clamp. Test to ensure it can resist kickback.

⚠ WARNING: Place the featherboard against the uncut portion of the workpiece to avoid kickback that could cause serious personal injury.

HOW TO MAKE A FEATHERBOARD

See Figure 17.

The featherboard is an excellent project for the saw. Select a solid piece of lumber approximately 3/4 in. thick, 3-5/8 in. wide and 18 in. long. Mark the center of the width on one end of the stock. Miter one-half of the width to 30° and miter the other half of the same end to 45° (see page 30 for information on miter cuts). Mark the board from the point at 6 in., 8 in., 10 in., and 12 in. Drill a 3/8 in. hole at the 8 in., 10 in., and 12 in. marks.

Prepare the saw for ripping as discussed on page 29. Set the rip fence to allow approximately a 1/4 in. “finger” to be cut in the stock. Feed the stock only to the mark previously made at 6 in. Turn the saw **OFF (O)** and allow the blade to completely stop rotating before removing the stock. Reset the rip fence and cut spaced rips into the workpiece to allow approximately 1/4 in. fingers and 1/8 in. spaces between the fingers.

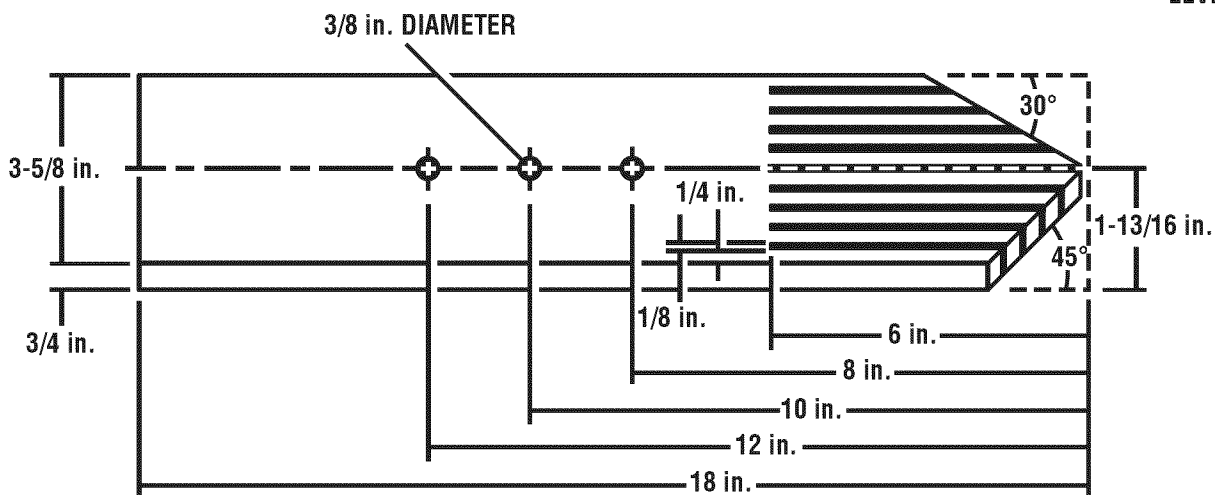

Fig. 17

HOW TO MOUNT A FEATHERBOARD

See Figure 18.

Remove the adjusting clamp knob, bolt, and washer from the miter fence holder. Place the bolt through one of the holes in the featherboard. Positioning the featherboard will depend on the placement of the bolt and the position of the sliding miter table on the rails. Place the washer on the bolt and attach the adjusting clamp knob, loosely. Position the featherboard with the hex head of the bolt in the miter table slot but do not tighten. Completely lower the saw blade. Position the rip fence to the desired adjustment for the cut to be performed and lock. Place the workpiece against the fence and over the saw blade area. Adjust the featherboard to apply resistance to the workpiece just forward of the blade. Securely tighten the adjusting clamp knob to secure the featherboard in place. Attach a C-clamp to further secure the featherboard to the edge of the sliding miter table.

⚠ WARNING: Do not locate the featherboard to the rear of the workpiece. If positioned improperly, kickback can result from the featherboard pinching the workpiece and binding the blade in the saw kerf. Failure to heed this warning can result in serious personal injury.

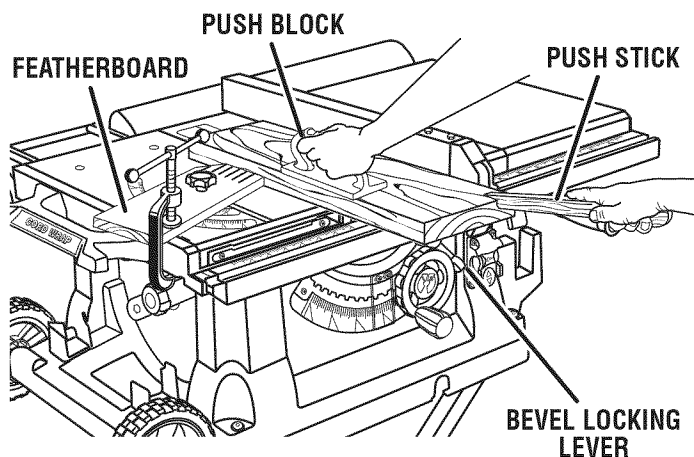

Fig. 18

OPERATION

TYPES OF CUTS

See Figure 19.

There are six basic cuts: 1) the cross cut, 2) the rip cut, 3) the miter cut, 4) the bevel cross cut, 5) the bevel rip cut, and 6) the compound (bevel) miter cut. All other cuts are combinations of these basic six. Operating procedures for making each kind of cut are given later in this section.

⚠ WARNING: Always make sure the blade guard and anti-kickback pawls are in place and working properly when making these cuts to avoid possible injury.

Cross cuts are straight 90° cuts made across the grain of the workpiece. The wood is fed into the cut at a 90° angle to the blade, and the blade is vertical.

Rip cuts are made with the grain of the wood. To avoid kickback while making a rip cut, make sure one side of the wood rides firmly against the rip fence.

Miter cuts are made with the wood at any angle to the blade other than 90°. The blade is vertical. Miter cuts tend to “creep” away from the miter fence during cutting. This can be controlled by holding the workpiece securely against the miter fence.

⚠ WARNING: Always use a push stick when cutting small pieces of wood, and also to finish the cut when ripping a long narrow piece of wood, to prevent your hands from getting close to the blade.

Bevel cuts are made with an angled blade. Bevel cross cuts are across the wood grain, and bevel rip cuts are with the grain. The rip fence must always be on the right side of the blade for bevel rip cuts.

Compound (or bevel) miter cuts are made with an angled blade on wood that is angled to the blade. Be thoroughly familiar with making cross cuts, rip cuts, bevel cuts, and miter cuts before trying a compound miter cut.

CUTTING TIPS

Dado and rabbet cuts are non-through cuts which can be either rip cuts or cross cuts. Carefully read and understand all sections of this operator’s manual before attempting any operation.

⚠ WARNING: Do not use blades rated less than the speed of this tool. Failure to heed this warning could result in personal injury.

- The kerf (the cut made by the blade in the wood) will be wider than the blade to avoid overheating or binding. Make allowance for the kerf when measuring wood.
- Make sure the kerf is made on the waste side of the measuring line.

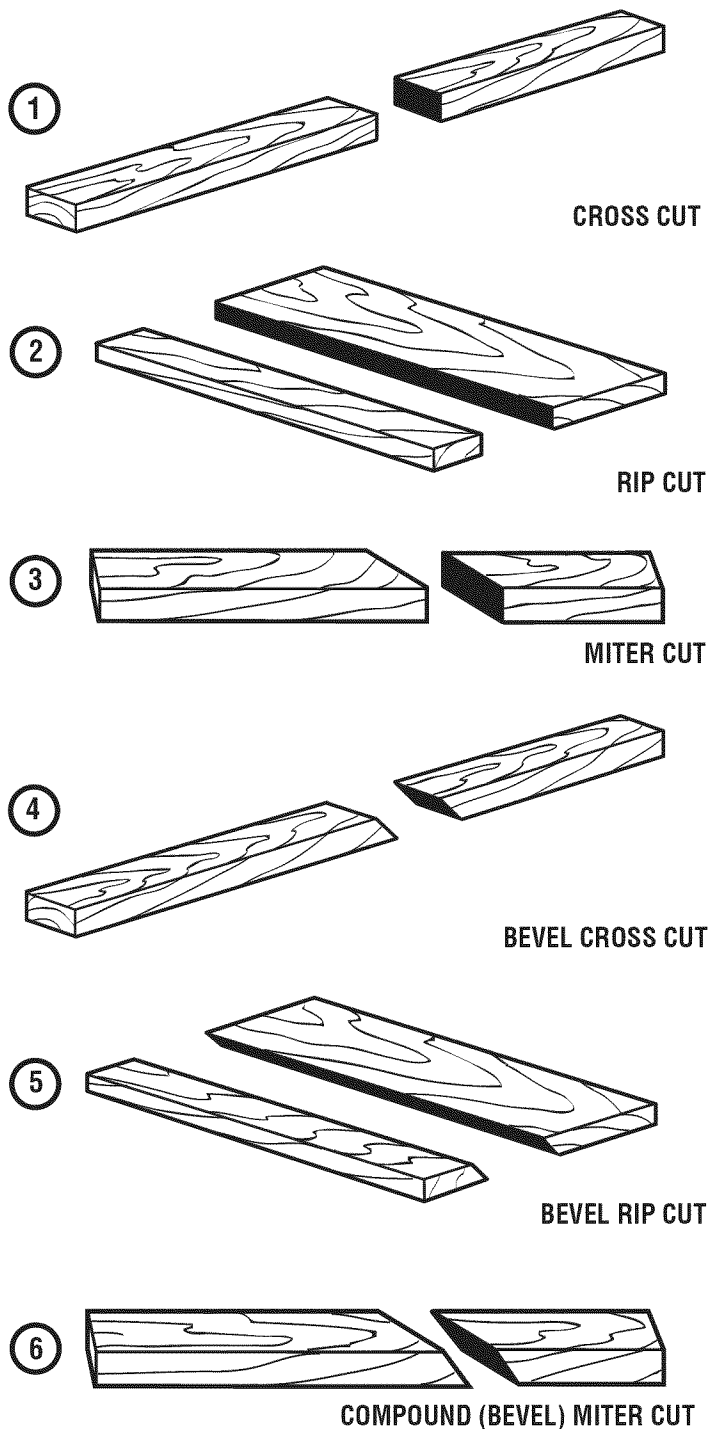

Fig. 19

- Cut the wood with the finish side up.
- Knock out any loose knots with a hammer before making the cut.
- Always provide proper support for the wood as it comes out of the saw.

OPERATION

TO CHANGE BLADE DEPTH

See Figure 20.

The blade depth should be set so that the outer points of the blade are higher than the workpiece by approximately 1/8 in. to 1/4 in. but the lowest points (gullets) are below the top surface.

- Push the bevel locking lever to the left for elevation mode.
- Raise the blade by turning the height/bevel adjusting handwheel counterclockwise or lower it by turning the handwheel clockwise.

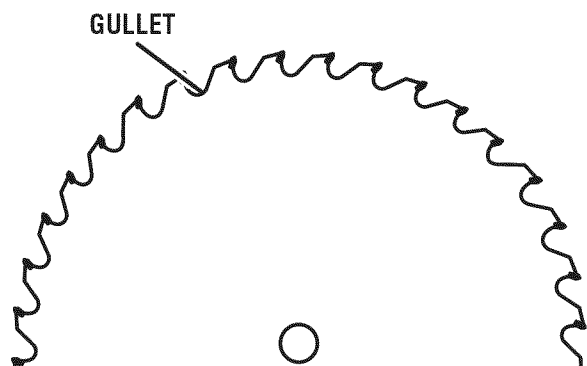

Fig. 20

TO CHANGE BLADE ANGLE

See Figure 21.

- Unplug the saw.
- Push the bevel locking lever to the left for angle mode.
- To angle the blade, push the height/bevel adjusting handwheel into the cabinet to engage bevel gear, and turn the handwheel until the bevel indicator shows the correct angle.
- Return the bevel locking lever securely to the right to lock the angle, while holding the height/bevel adjusting handwheel in place.

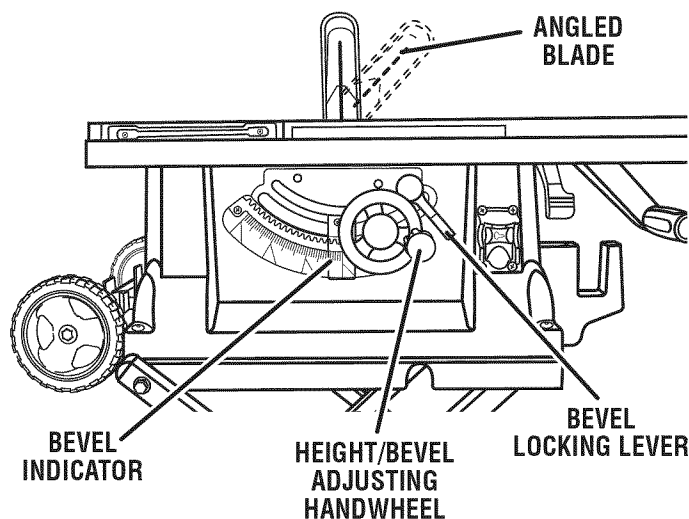

Fig. 21

CHECKING SLIDING MITER TABLE AND MAKING ADJUSTMENTS

TO POSITION THE SLIDING MITER TABLE

See Figures 22 - 23.

A slide bolt is located on the front of the saw between the saw table and the front scale. When the arrows on both the saw table and sliding table are aligned, this bolt slides through the holes in both tables locking them into a fixed position.

The sliding table has three positions providing additional front support when working with larger workpieces. Always lock the sliding table when not in use.

To unlock the sliding miter table:

- Lift the tab on the slide bolt and move the bolt to the far left.
- Lock the bolt into position by pushing the tab down and into the far left-hand notch.

To lock the sliding miter table:

- Lift the tab and slide the bolt through both tables.
- Lock the bolt into position by pushing the tab down and into the notch.

NOTE: When moving the miter base, keep hands and fingers out of areas where they may be pinched. Pull the miter base into position with fingers extended and using only your thumb as shown in figure 23.

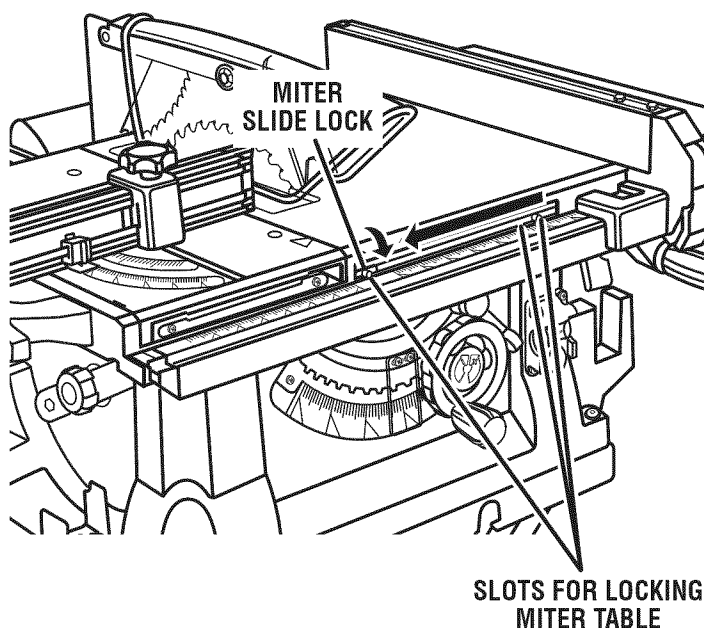

Fig. 22

OPERATION

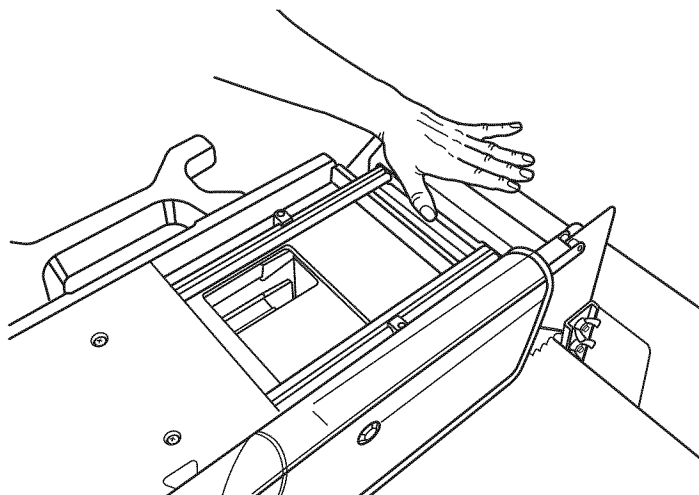

Fig. 23

TO CHECK MITER BASE PARALLELISM

See Figures 24 - 25.

- Unplug the saw.
- Set saw up as if you were preparing to make a cut. Tighten rail clamps, miter locking clamps, adjusting clamp knob, etc.
- Slide miter table (A) to the front of miter base (B) as far as it will go. Place a reference mark (C) near the end of the miter table as shown in figure 24.

NOTE: Front of miter base is on infeed side of saw.

- Place a reference mark on one of the blade teeth (D) and rotate the blade (E) so that the reference mark on the blade is at the front of the throat plate.
 - Place a framing square (G) against the blade and align with reference mark on miter table. Measure the distance between the blade and the edge of miter table.
- NOTE:** Place framing square between carbide teeth and measure from blade. This step will insure framing square is square against blade from the front to back of blade.

- Remove framing square and slide miter table to the rear of miter base as far as it will go.
- Rotate the blade so the reference mark on the blade is at the rear of the throat plate. Measuring from the same mark on the blade at the rear will eliminate the effect of blade wobble.
- Place framing square against the blade and align with the same reference mark on the miter table. Measure the distance between the blade and the edge of the miter table at the rear.

- Compare whether the front and rear measurements are the same. If they are the same, proceed with checking the miter fence alignment. If not, this indicates the miter base needs aligning. Miter base must then be adjusted before checking miter fence alignment. See **To Adjust The Miter Table Base** section that follows.

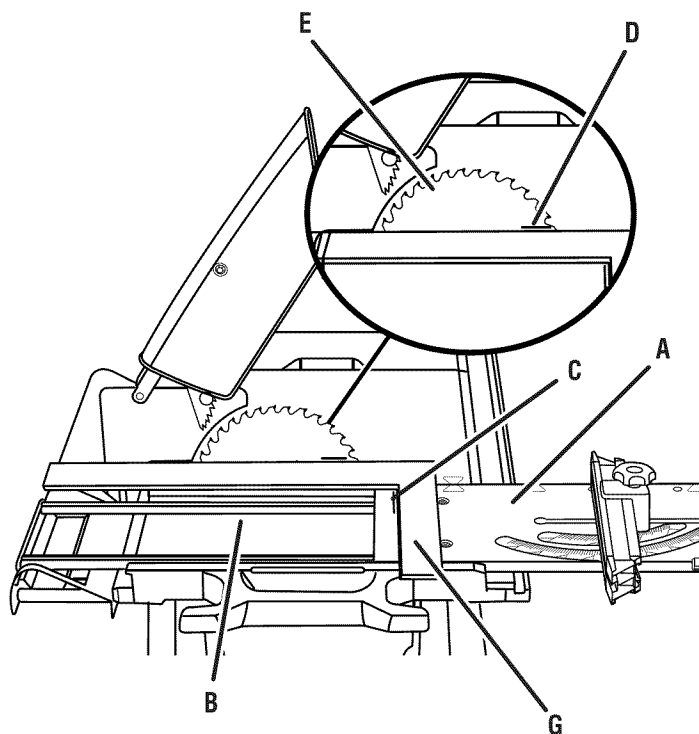

Fig. 24

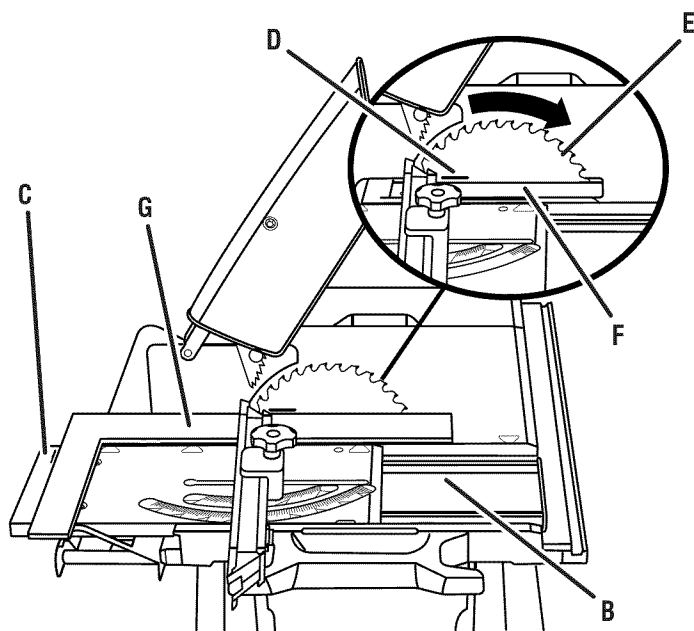

Fig. 25

OPERATION

TO ADJUST THE MITER TABLE BASE

See Figure 26.

Remember: Check all settings before loosening screws for the following procedures. Once screws have been loosened, these settings must be reset.

- Unplug the saw.
- Set the miter fence at 0° then securely tighten the adjusting clamp knob.
- Push the sliding miter table to the back and loosen the right-front screw from beneath the table saw cabinet.
- Loosen the nylock nut beneath the front-left eccentric screw.
- Place one side of a framing square firmly against the miter fence and the other side against the saw blade.
- Using a flathead screwdriver, turn the eccentric screw until the miter fence and the blade are square.
- Hold the eccentric screw in place with the screwdriver and tighten the nylock nut securely.
- Retighten the front right-hand screw.

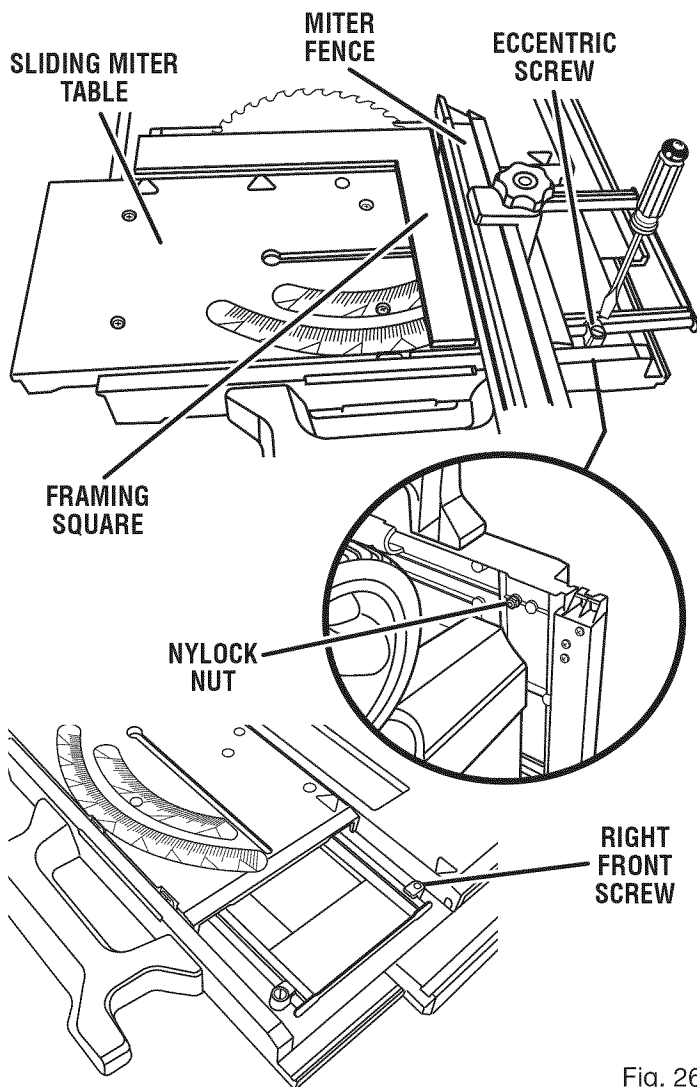

Fig. 26

TO CHECK MITER FENCE ALIGNMENT

See Figure 27.

The miter fence must be perpendicular to the blade when set at zero degrees.

- Set the miter fence (H) at 0°. Miter indicator (I) should be set precisely on 0° and secured in place with the adjusting clamp knob (J).

NOTE: The quick-stop is not necessary for this checking procedure. However, you may want to check and adjust it to 0° at this time. See the **To Adjust Quick-Stop** section that follows.

- Place a framing square (G) firmly against the miter fence (H), with the other side against the blade (E).
- Check whether the miter fence and blade are square with each other. With the framing square against the miter fence there should be no gap from the front to the rear of the blade.
- If a gap exists, the miter fence may be out of square.
- Rotate the blade and recheck. If there is an inconsistent gap between the front and rear of the blade, the miter table base needs aligning.

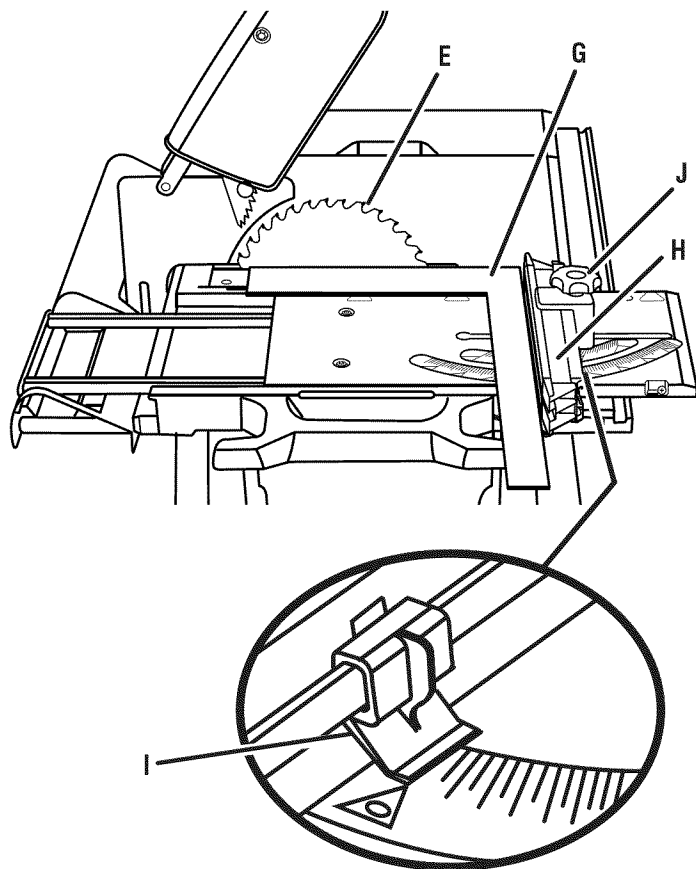

Fig. 27

OPERATION

TO ADJUST QUICK-STOP

See Figure 28.

The quick-stop is preset at the factory to stop the miter fence at exactly 0°. However, when sliding miter table adjustments are made, these adjustments may cause the quick-stop to need adjusting. Check quick-stop with miter scale set at 0°. If adjustments are needed, proceed with the following steps:

- Loosen the eccentric screw holding the quick-stop.
- Place the quick-stop against the miter fence with miter scale set at 0°.
- Adjust eccentric screw until it holds quick-stop securely against miter fence.
- Retighten hex nut, securing eccentric screw and quick-stop.
- Check your work. If the quick-stop is not at zero degrees, repeat above steps.

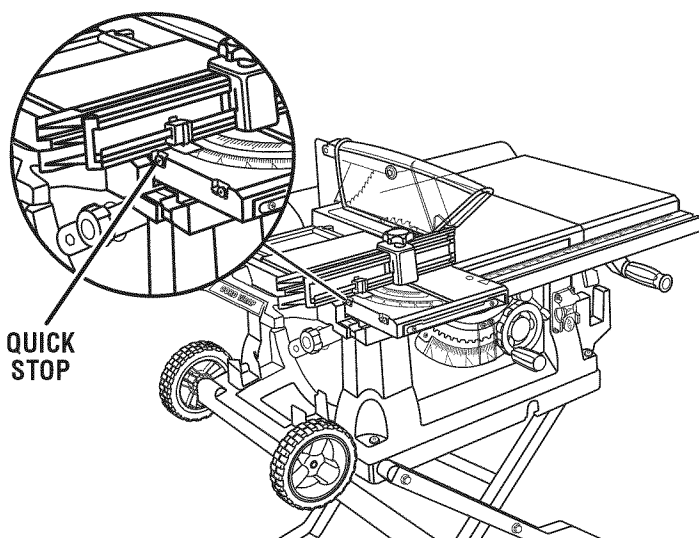

Fig. 28

WARNING: To reduce the risk of injury, always make sure the rip fence is parallel to the blade before beginning any operation.

TO SET THE RIP FENCE SCALE INDICATOR TO THE BLADE

See Figure 29.

Begin with the blade at a zero angle (straight up).

- Unplug the saw.
- Raise the blade guard.
- Loosen the rip fence by lifting the locking lever.
- Using a framing square, set the rip fence 2 in. from the blade tip edge.
- Loosen the screw on the scale indicator.
- Tighten the screw and check the dimension and the rip fence.

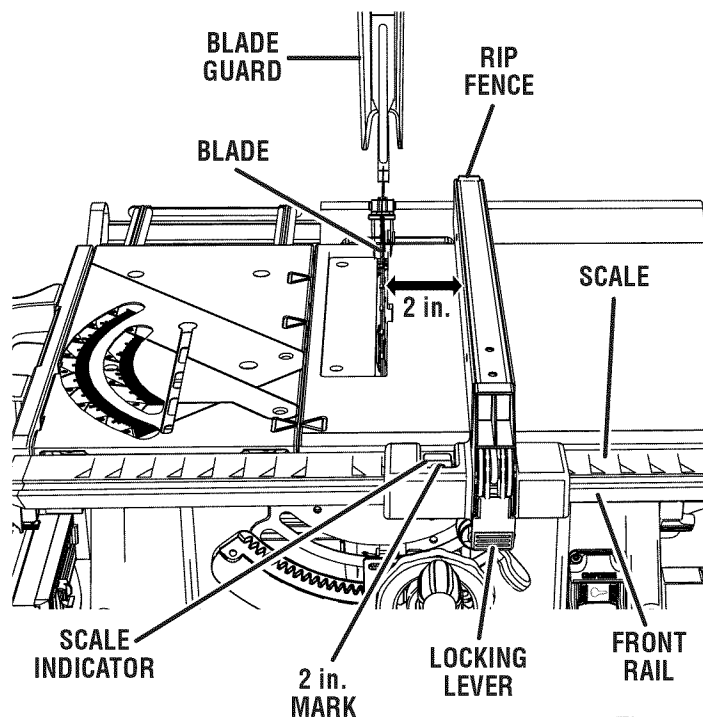

Fig. 29

TO USE THE RIP FENCE

See Figure 30.

- Place the rear lip on the rear of the saw table and pull slightly toward the front of the unit.
- Lower the front end of the rip fence onto the guide surfaces on top of the front rail.
- Push the locking lever down to automatically align and secure the fence.

Check for a smooth gliding action. If adjustments are needed, see **To Check the Alignment of the Rip Fence to the Blade** in the *Adjustment* section of this manual.

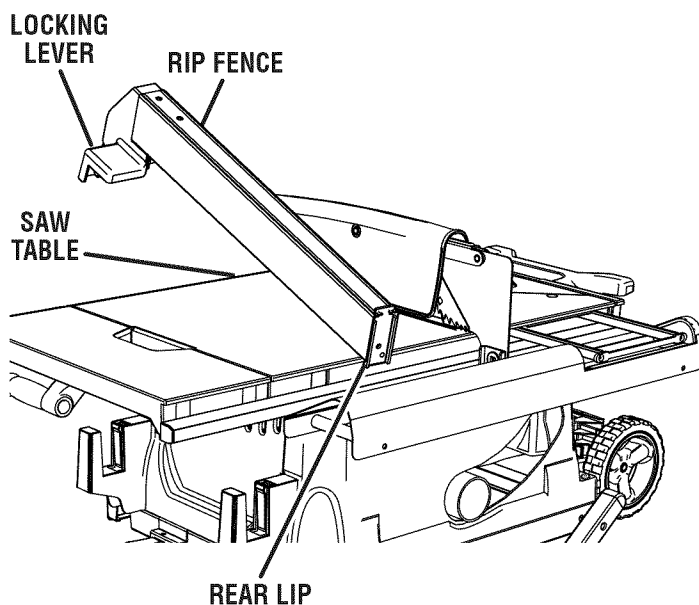

Fig. 30

OPERATION

TO USE OUTFEED SUPPORT

See Figure 31.

The outfeed support slides to give the operator additional support for cutting long workpieces.

- With the table saw in the **OFF** position, stand behind the saw.
- Grasp the outfeed support with both hands and pull it until it is fully extended.

TO USE THE TABLE EXTENSION

See Figure 32.

The table extension provides the operator with additional table width for supporting wider workpieces. Use the scale on the front rail when a specific width is desired.

To extend:

- Set the rip fence to 16 in.
- Push the table extension lever beneath the saw table towards the back of the saw.
- Grasp the table extension with both hands and pull it until the scale on the front rail indicates the desired measurement.
- Retighten the table extension lever by pulling it towards the front of the saw.

To close:

- Push the table extension lever beneath the saw table towards the back of the saw.
- Push the table extension with both hands back toward the saw table.
- Retighten the table extension lever by pulling it towards the front of the saw.

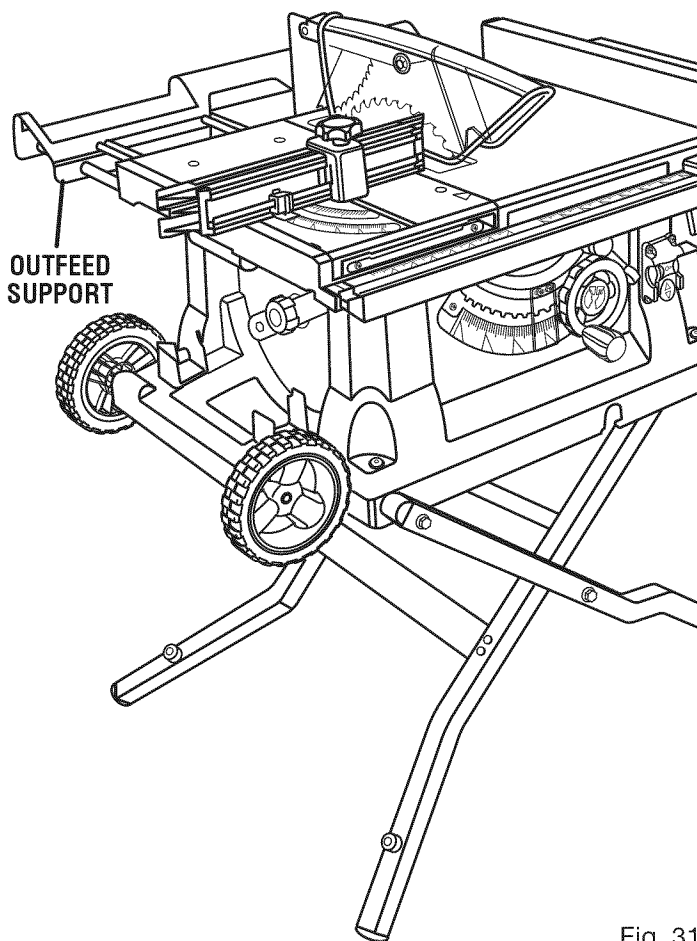

Fig. 31

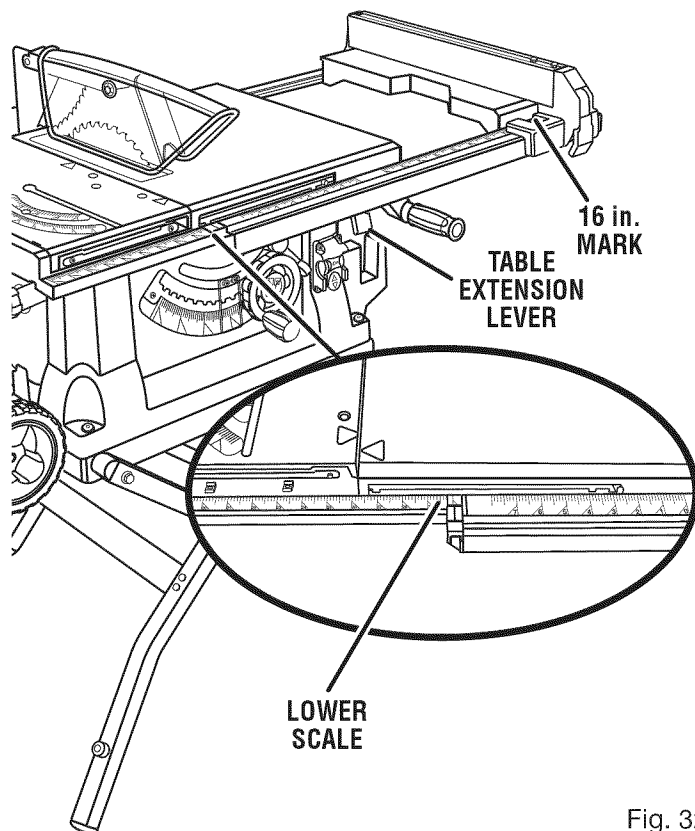

Fig. 32

OPERATION

HEELING (PARALLELING) THE BLADE

See Figures 33 - 35.

⚠ WARNING: The blade must be square so the wood does not bind resulting in kickback. Failure to do so could result in serious personal injury.

Do not loosen any screws for this adjustment until you have checked with a square and made test cuts to be sure adjustments are necessary. Once the screws are loosened, these items must be reset.

- Unplug the saw.
- Lift the blade guard. Raise the blade all the way by turning the height/bevel adjusting handwheel.
- Mark beside one of the blade teeth at the front of the blade. Place a framing square even with the front of the saw table and the side of the saw blade as shown in figure 33.
- Turn the blade so the marked tooth is at the back.
- Move the framing square to the rear and again measure the distance. If the distances are the same, the blade is square.

If the distances are different:

- Extend the extension table (see page 27).
- Loosen adjusting bolts (1) and (3).

NOTE: The adjusting bolts are located above the height/bevel adjusting handwheel and under the saw table in the front of the saw.

- Turn adjusting bolt (2) left or right until the blade is square.

NOTE: If the back of the blade was too far from the framing square, place a block of wood on the left side of the blade and push it into the blade until the blade is square. Retighten the bolts.

- If the back of the blade was too close to the framing square, place a block of wood on the right side of the blade and push it into the blade until the blade is square. Retighten the bolts.

⚠ WARNING: To reduce the risk of injury from kickback, align the rip fence to the blade following any blade adjustments. Always make sure the rip fence is parallel to the blade before beginning any operation.

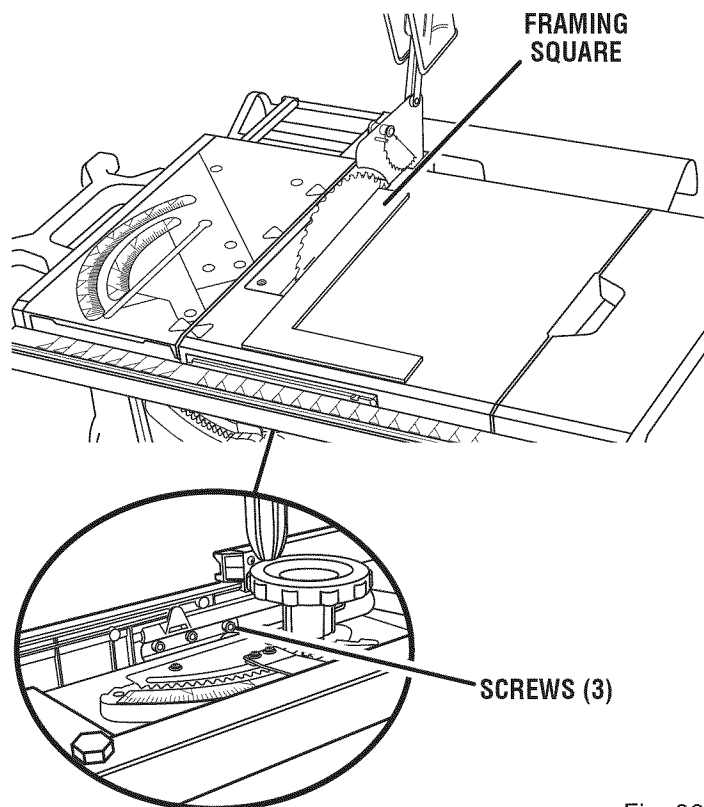

Fig. 33

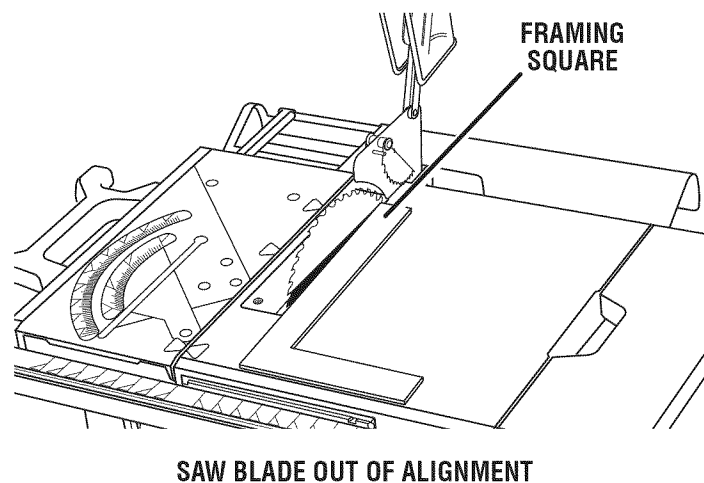

Fig. 34

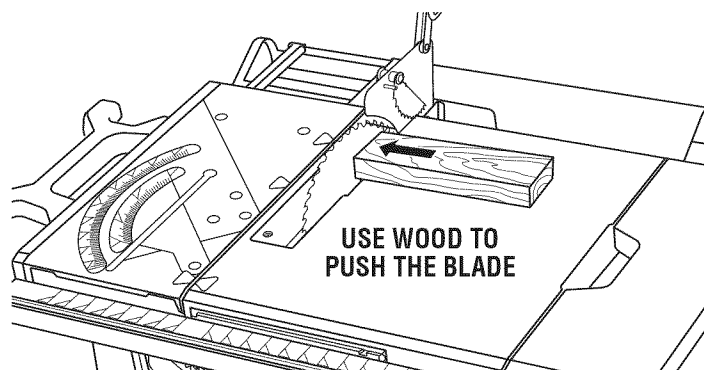

Fig. 35

OPERATION

MAKING CUTS

The blade provided with the saw is a high-quality combination blade suitable for ripping and cross cut operations. Carefully check all setups and rotate the blade one full revolution to assure proper clearance before connecting saw to power source. Stand slightly to the side of the blade path to reduce the chance of injury should kickback occur.

WARNING: Do not use blades rated less than the speed of this tool. Failure to heed this warning could result in personal injury.

Use the miter fence when making cross, miter, bevel, and compound miter cuts. To secure the angle, lock the miter fence in place by twisting the lock knob clockwise. Always tighten the lock knob securely in place before use.

NOTE: It is recommended that you place the piece to be saved on the left side of the blade and that you make a test cut on scrap wood first.

TO MAKE A CROSS CUT

See Figures 36 - 37.

WARNING: Make sure the blade guard assembly is installed and working properly to avoid serious possible injury.

WARNING: Using the rip fence as a cutoff gauge when cross cutting will result in kickback which can cause serious personal injury.

CROSS CUT

PLACE RIGHT HAND ON MITER FENCE HOLDER HERE

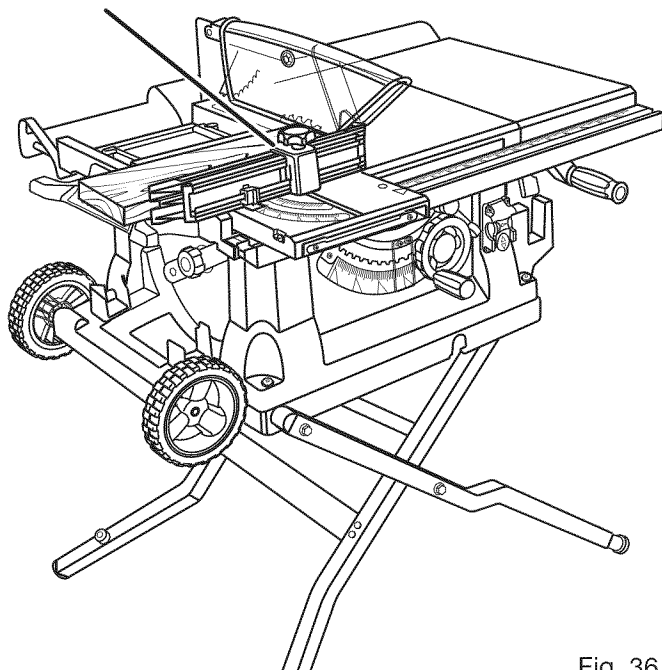
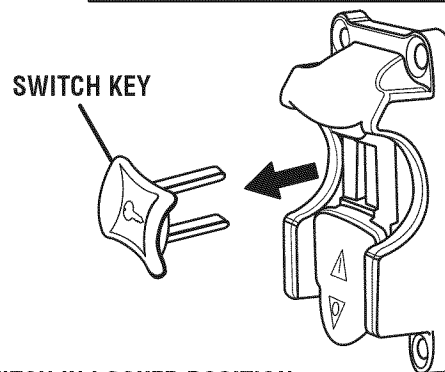
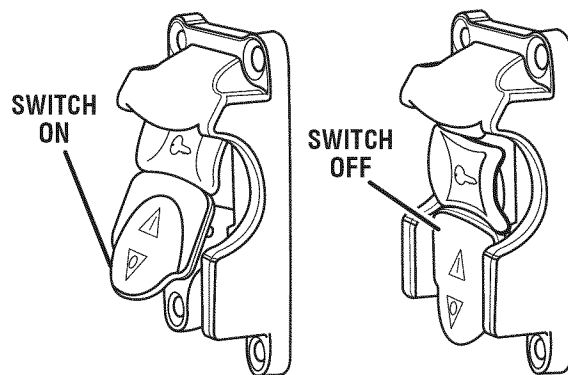

Fig. 36



SWITCH IN LOCKED POSITION

Fig. 37

- Remove the rip fence.
 - Set the blade to the correct depth for the workpiece.
 - Set the miter fence to 0° and tighten the adjusting clamp knob.
 - Make sure the wood is clear of the blade before turning on the saw.
 - To turn the saw on, lift the switch button.
 - To turn saw off, press the switch button down.
- NOTE:** To prevent unauthorized use, remove the switch key as shown in figure 37.
- Let the blade build up to full speed before moving the workpiece into the blade.
 - Hold the workpiece firmly with both hands on the miter fence and feed the workpiece into the blade.
- NOTE:** The hand closest to the blade should be placed on the adjusting clamp knob and the hand farthest from the blade should be placed on the workpiece.
- When the cut is made, turn the saw off. Wait for the blade to come to a complete stop before removing the workpiece.

OPERATION

MAKING A RIP CUT

See Figure 38.

- ▲ **WARNING:** Make sure the blade guard assembly is installed and working properly to avoid serious possible injury.
- Set the blade to the correct depth for the workpiece.
- Position the rip fence the desired distance from the blade for the cut and securely lock the handle.
- Make sure the wood is clear of the blade before turning on the saw.
- When ripping a long workpiece, place a support the same height as the table surface behind the saw for the cut work.
- Turn the saw on.
- Position the workpiece flat on the table with the edge flush against the rip fence. Let the blade build up to full speed before feeding the workpiece into the blade.
- Once the blade has made contact with the workpiece, use the hand closest to the rip fence to guide it. Make sure the edge of the workpiece remains in solid contact with both the rip fence and the surface of the table. If ripping a narrow piece, use a push stick and/or push blocks to move the piece through the cut and past the blade.
- When the cut is made, turn the saw off. Wait for the blade to come to a complete stop before removing the workpiece.

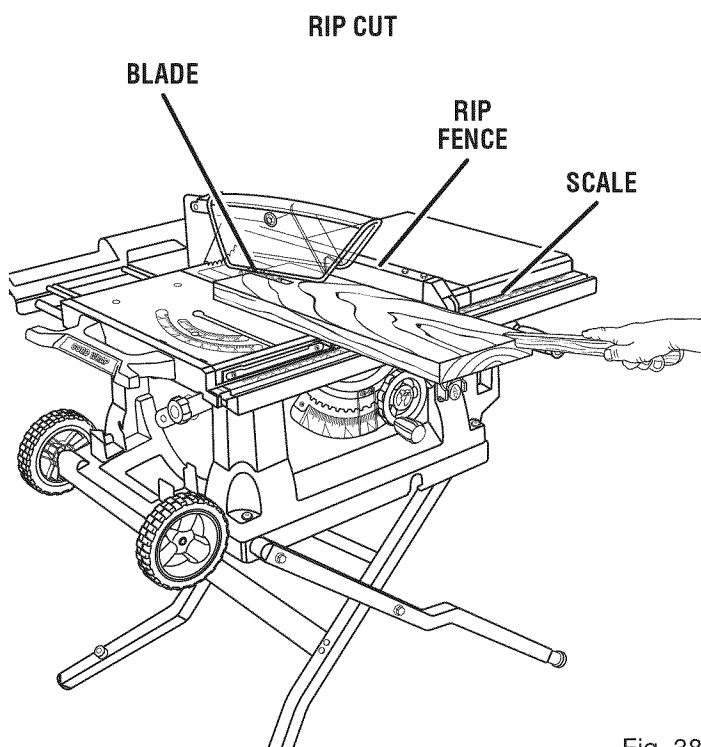

Fig. 38

MAKING A MITER CUT

See Figure 39.

- ▲ **WARNING:** Make sure the blade guard assembly is installed and working properly to avoid possible serious injury.
- Remove the rip fence.
- Set the blade to the correct depth for the workpiece.
- Set the miter gauge to the desired angle and tighten the adjusting clamp knob.
- Make sure the wood is clear of the blade before turning on the saw.
- Turn the saw on.
- Let the blade build up to full speed before moving the workpiece into the blade.
- Hold the workpiece firmly with both hands on the miter gauge and feed the workpiece into the blade.
- **NOTE:** The hand closest to the blade should be placed on the adjusting clamp knob and the hand farthest from the blade should be placed on the workpiece.
- When the cut is made, turn the saw off. Wait for the blade to come to a complete stop before removing the workpiece.

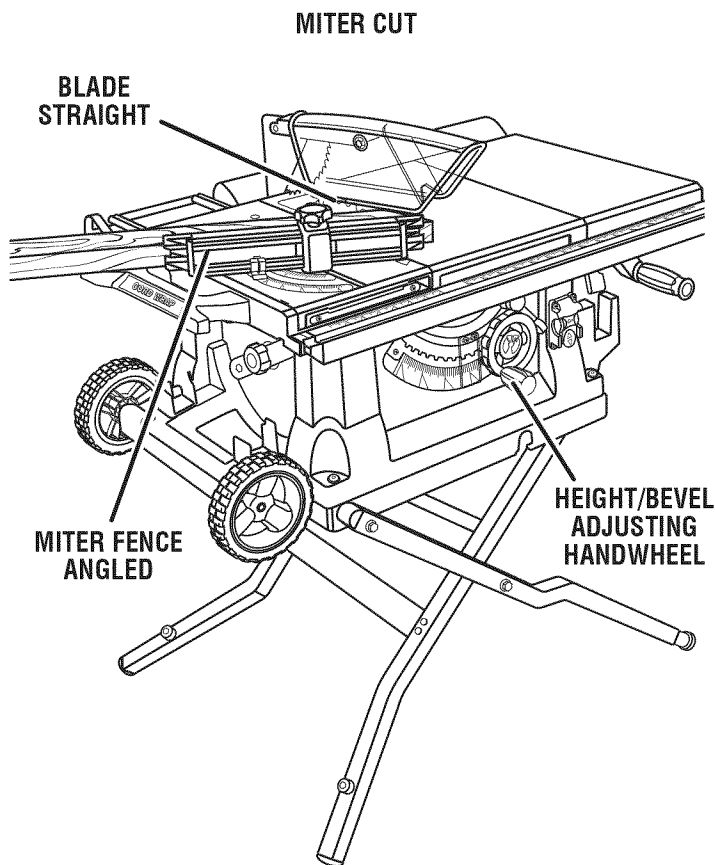

Fig. 39

OPERATION

VIEWED FROM THE FRONT, BELOW THE TABLE SAW

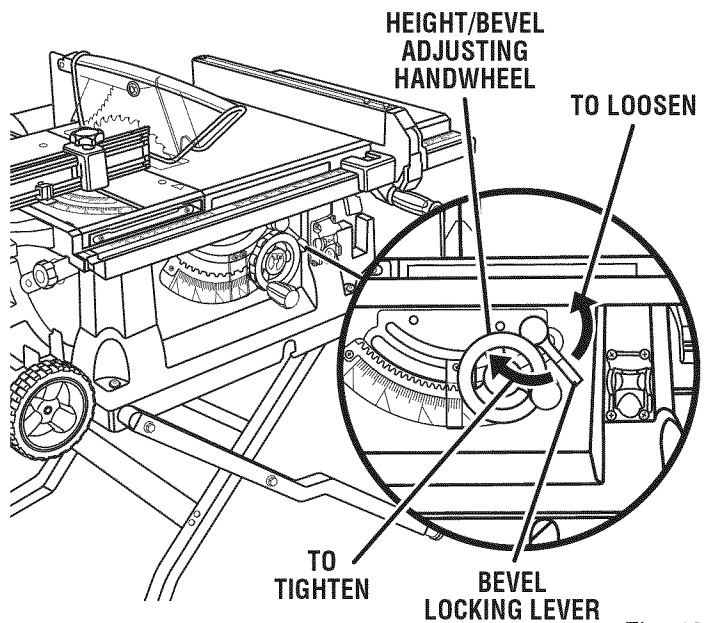

Fig. 40

MAKING A BEVEL CROSS CUT

See Figures 40 - 41.

WARNING: Make sure the blade guard assembly is installed and working properly to avoid possible serious injury.

- Remove the rip fence.
- Unlock the bevel locking lever.
- Adjust the bevel angle to the desired setting.
- Lock the bevel locking lever.
- Set the blade to the correct depth for the workpiece.

BEVEL CROSS CUT

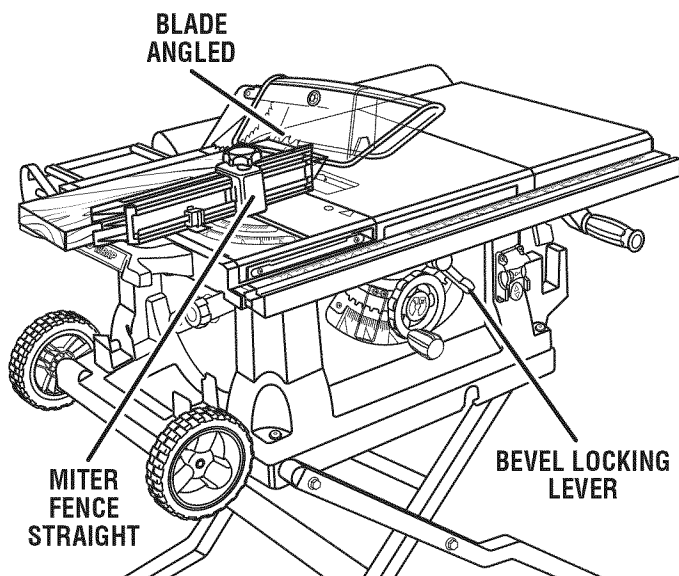

Fig. 41

- Set the miter fence to 0° and tighten the adjusting clamp knob.
 - Make sure the wood is clear of the blade before turning on the saw.
 - Turn the saw on.
 - Let the blade build up to full speed before moving the workpiece into the blade.
 - Hold the workpiece firmly with both hands on the miter gauge and feed the workpiece into the blade.
- NOTE:** The hand closest to the blade should be placed on the adjusting clamp knob and the hand farthest from the blade should be placed on the workpiece.
- When the cut is made, turn the saw off. Wait for the blade to come to a complete stop before removing the workpiece.

MAKING A BEVEL RIP CUT

See Figure 42.

WARNING: Make sure the blade guard assembly is installed and working properly to avoid serious personal injury.

WARNING: The rip fence must be on the left side of the blade to avoid trapping the wood and causing kickback. Placement of the rip fence to the right of the blade will result in kickback and the risk of serious personal injury.

- Remove the miter fence.
- Unlock the bevel locking lever.
- Adjust the bevel angle to the desired setting.
- Lock the bevel locking lever.
- Set the blade to the correct depth for the workpiece.

BEVEL RIP CUT

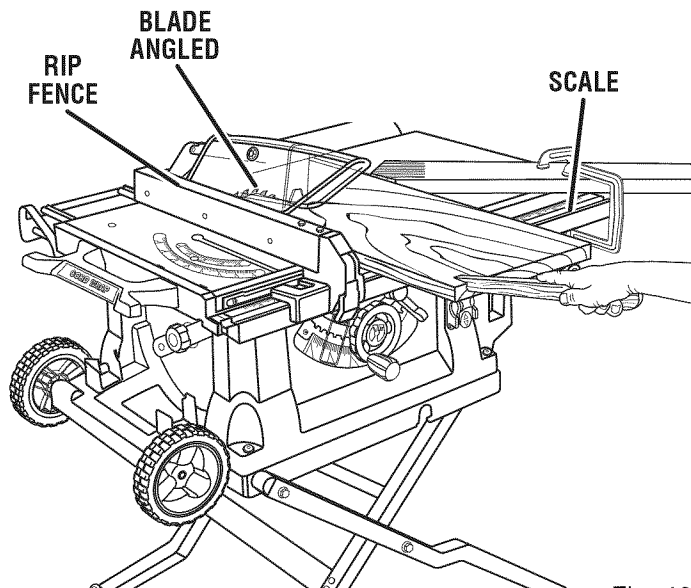

Fig. 42

OPERATION

- Position the rip fence the desired distance from the blade for the cut and securely lock the handle.
- Make sure the wood is clear of the blade before turning on the saw.
- When ripping a long workpiece, place a support the same height as the table surface behind the saw for the cut work.
- Turn the saw on.
- Position the workpiece flat on the table with the edge flush against the rip fence. Let the blade build up to full speed before feeding the workpiece into the blade.
- Once the blade has made contact with the workpiece, use the hand closest to the rip fence to guide it. Make sure the edge of the workpiece remains in solid contact with both the rip fence and the surface of the table. If ripping a narrow piece, use a push stick to move the piece through the cut and past the blade.
- When the cut is made, turn the saw off. Wait for the blade to come to a complete stop before removing the workpiece.

MAKING A COMPOUND (BEVEL) MITER CUT

See Figure 43.

WARNING: Make sure the blade guard assembly is installed and working properly to avoid possible serious injury.

COMPOUND (BEVEL) MITER CUT

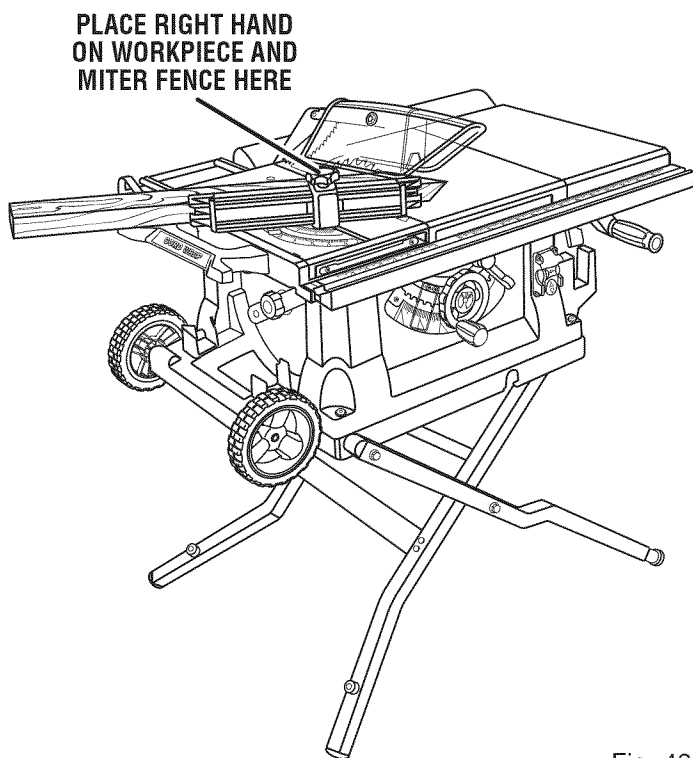

Fig. 43

- Remove the rip fence.
 - Unlock the bevel locking lever.
 - Adjust the bevel angle to the desired setting.
 - Lock the bevel locking lever.
 - Set the blade to the correct depth for the workpiece.
 - Set the miter fence to the desired angle and tighten adjusting clamp knob.
 - Make sure the wood is clear of the blade before turning on the saw.
 - Turn the saw on.
 - Let the blade build up to full speed before moving the workpiece into the blade.
 - Hold the workpiece firmly with both hands on the miter fence and feed the workpiece into the blade.
- NOTE:** The hand closest to the blade should be placed on the adjusting clamp knob and the hand farthest from the blade should be placed on the workpiece.
- When the cut is made, turn the saw off. Wait for the blade to come to a complete stop before removing the workpiece.

MAKING A LARGE PANEL CUT

See Figure 44.

Make sure the saw is properly secured to a work surface to avoid tipping from the weight of a large panel.

WARNING: Make sure the blade guard assembly is installed and working properly to avoid possible serious injury.

LARGE PANEL CUT

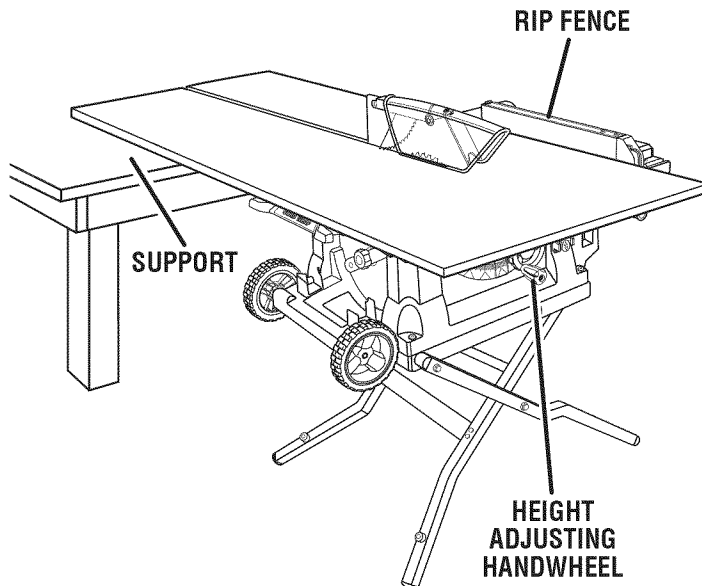

Fig. 44

OPERATION

⚠ WARNING: Never make freehand cuts (cuts without the miter fence or rip fence), which can result in serious injury.

- Place a support the same height as the top of the saw table behind the saw for the cut work. Add supports to the sides as needed.
- Depending on the shape of the panel, use the rip fence or miter fence. If the panel is too large to use either the rip fence or the miter fence, it is too large for this saw.
- Make sure the wood does not touch the blade before you turn on the saw.
- Turn the saw on.
- Position the workpiece flat on the table with the edge flush against the rip fence. Let the blade build up to full speed before feeding the workpiece into the blade.
- Use a push stick to move the piece through the cut and past the blade.
- When the cut is made, turn the saw off. Wait for the blade to come to a complete stop before removing the workpiece.

MAKING A NON-THROUGH CUT

See Figure 45.

Non-through cuts (made with a standard 10 in. blade) can be made with the grain (ripping) or across the grain (cross cut). The use of a non-through cut is essential to cutting grooves, rabbets, and dados. This is the only type cut that is made without the blade guard assembly installed. Make sure the blade guard assembly is reinstalled upon completion of this type of cut. Read the appropriate section which describes the type of cut in addition to this section on non-through or dado cuts. For example, if your non-through cut is a straight cross cut, read and understand the section on straight cross cuts before proceeding.

⚠ WARNING: When making a non-through cut, the cutter is covered by the workpiece during most of the cut. Be alert to the exposed cutter at the start and finish of every cut to avoid the risk of personal injury.

⚠ WARNING: Never feed wood with your hands when making any non-through cut such as rabbets or dados. To avoid personal injury, always use push blocks, push sticks, and featherboards.

- Unplug the saw.
- Remove the blade guard assembly.
- Unlock the bevel locking lever.
- Adjust the bevel angle to the desired setting.
- Lock the bevel locking lever.
- Set the blade to the correct depth for the workpiece.
- Depending on the shape and size of the wood, use either the rip fence or miter gauge.
- Plug the saw into the power source and turn the saw on.
- Let the blade build up to full speed before moving the workpiece into the blade.
- Always use push blocks, push sticks, and featherboards when making non-through cuts to avoid the risk of serious injury.
- When the cut is made, turn the saw off. Wait for the blade to come to a complete stop before removing the workpiece.

Once all non-through cuts are completed:

- Unplug your saw.
- Reinstall the blade guard assembly.

NON-THROUGH CUT

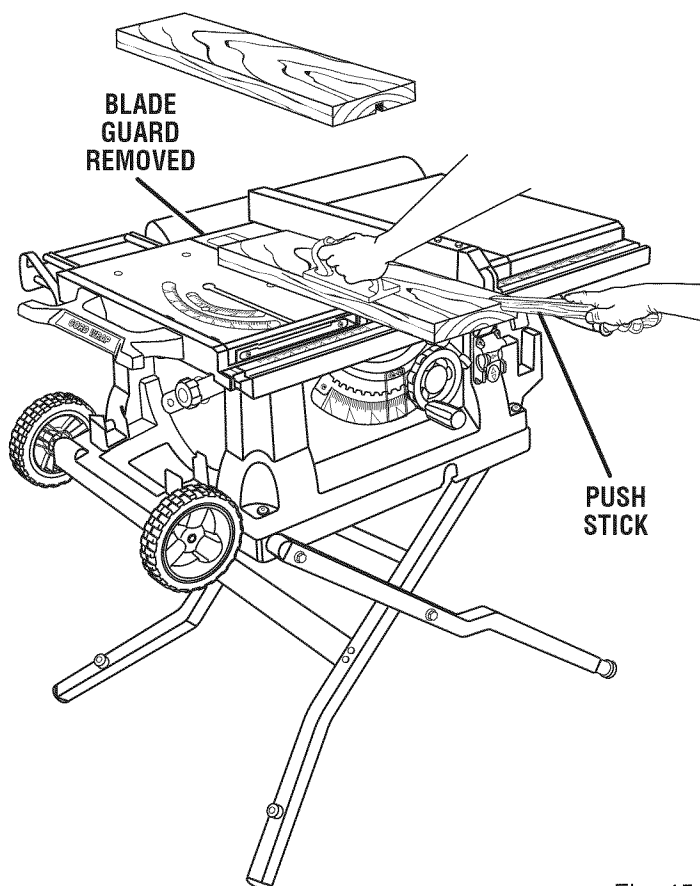

Fig. 45

OPERATION

MAKING A DADO CUT

See Figure 46.

An optional dado throat plate is required for this procedure (see the *Accessories* section of this manual and check with the retailer where the table saw was purchased). All blades and dado sets must not be rated less than the speed of this tool. This saw is designed for use with a 6 in. stack dado (up to width of 5/8 in.). Do not use an adjustable dado on this saw.

⚠ WARNING: Always use push blocks, push sticks, or featherboards when making dado cuts to avoid the risk of serious injury.

⚠ WARNING: Always store the blade washer and throat plate in secure location when changing back to saw blade. Failure to do so may result in possible injury and damage to the tool.

- Unplug the saw.
 - Remove the blade guard assembly.
 - Remove the blade nut, blade washer, and saw blade.
 - Mount the dado blade, according to manufacturer instructions, using the blade and chippers appropriate for the desired width of cut.
 - Reinstall the blade nut.
- NOTE:** The blade washer may be used provided the arbor shaft extends slightly beyond the arbor nut.
- Make sure the blade nut is fully engaged and the arbor extends past a securely tightened blade nut.
 - Install the dado throat plate and rotate the blade by hand to make sure it turns freely then lower the blade.
 - Depending on the shape and size of the wood, use either the rip fence or miter gauge.
 - Turn the power switch to the on position.

NOTE: Make sure the wood does not touch the blade before you turn on the saw. Let the blade build up to full speed before feeding the workpiece into the blade.

- Position the workpiece flat on the table with the edge flush against the rip fence or miter gauge.

- Use a push block or push stick to move the wood through the cut past the blade. Never push a small piece of wood into the blade with your hand, always use a push stick. The use of push blocks, push sticks, and featherboards are necessary when making non-through cuts.
- When the cut is made, turn the saw off. Wait for the blade to come to a complete stop before removing the workpiece.

Once all dado cuts are completed:

- Unplug your saw.
- Reinstall the spreader/riving knife in the “up” position then install the blade guard and anti-kickback pawls.

DADO CUT

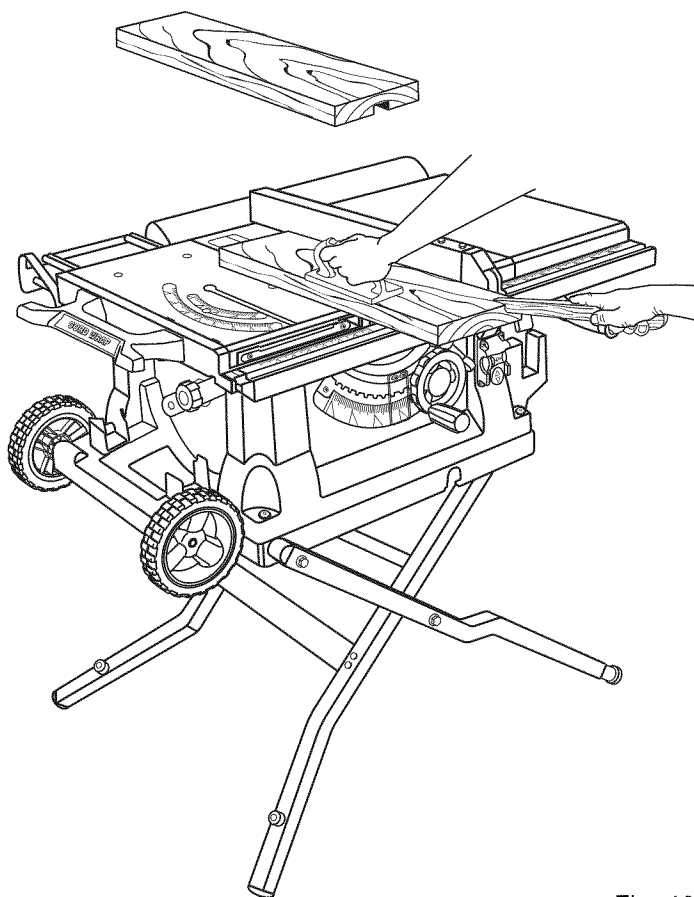

Fig. 46

ADJUSTMENTS

⚠ WARNING: Before performing any adjustment, make sure the tool is unplugged from the power supply. Failure to heed this warning could result in serious personal injury.

⚠ WARNING: Blades coast after turn off. Possible serious injury can occur if hands come in contact with blade.

The table saw has been adjusted at the factory for making very accurate cuts. However, some of the components might have been jarred out of alignment during shipping. Also, over a period of time, readjustment will probably become necessary due to wear.

To avoid unnecessary set-ups and adjustments, a good practice is to check your setups carefully with a framing square and make practice cuts in scrap wood before making finish cuts in good workpieces. Do not start any adjustments until you have checked with a square and made test cuts to be sure adjustments are needed.

TO REPLACE THE BLADE

See Figures 47 - 49.

NOTE: Arbor shaft has left hand threads.

- Unplug the saw.
- Lower the saw blade, raise or remove the blade guard, and remove the throat plate.
- Raise the saw blade to full height.
- Make sure the bevel locking lever is locked.
- Insert the open end of the small blade wrench onto the flats on the arbor shaft.
- Insert the closed end of the larger blade wrench over the hex nut. Holding both wrenches firmly, pull the outside wrench (right side) forward while pushing the inside (left side) to the back of the saw.
- Remove the blade.

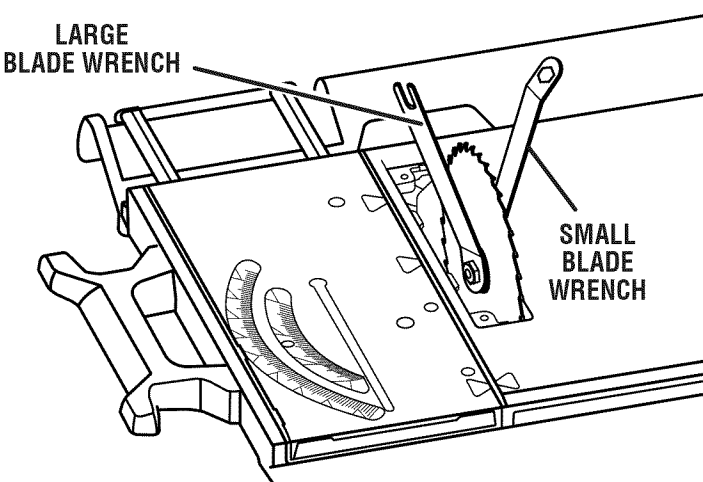

Fig. 47

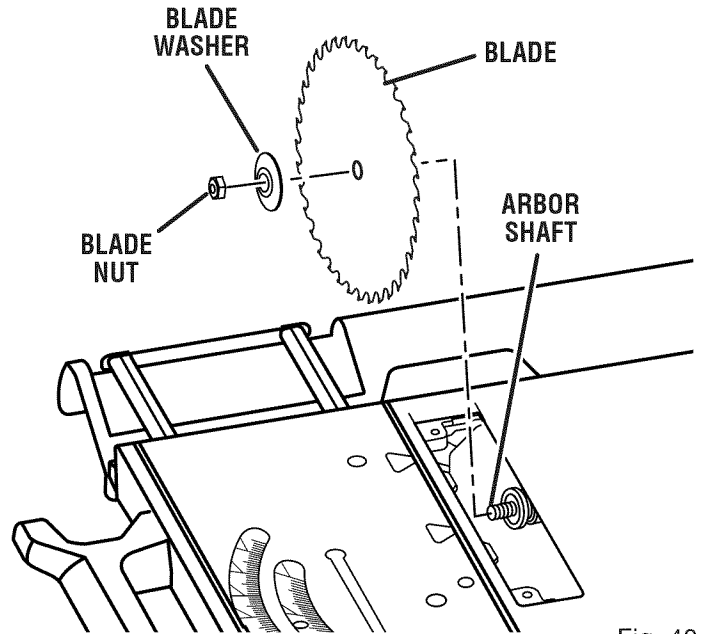

Fig. 48

To install a standard blade:

- Place the new blade on the arbor shaft (the teeth must point down toward the front of the saw to work properly).
- Place the blade washer and the blade nut over the arbor shaft. Be sure the dome side of the blade washer faces out from the blade and that all items are snug against the arbor housing. Make sure the blade nut is securely tightened. Do not overtighten.
- Rotate the blade by hand to make sure it turns freely.
- Lower the saw blade and reinstall the throat plate.

NOTE: To replace the blade with an accessory blade, follow the instructions provided with the accessory.

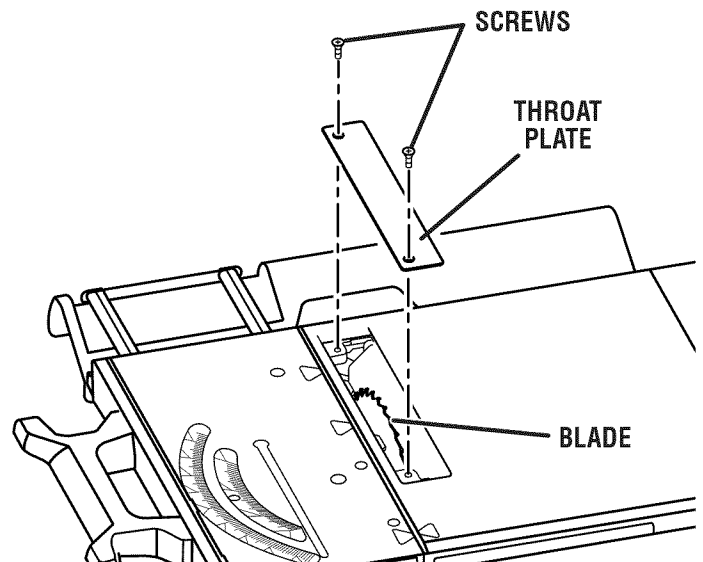

Fig. 49

ADJUSTMENTS

TO CHECK AND ALIGN THE SPREADER, SAW BLADE, AND BLADE GUARD ASSEMBLY

See Figure 50.

If the blade guard assembly is out of alignment with the saw blade, adjust the alignment of the blade guard assembly. The spreader must be aligned with the saw blade.

To check alignment of the spreader:

- Unplug the saw.
- Raise the saw blade by turning the height/bevel adjusting handwheel counterclockwise.
- Lift the anti-kickback pawls and place a framing square or straight edge against both the saw blade and the spreader.
- The saw blade and spreader are aligned when the framing square contacts both the blade and spreader evenly with no gaps.

If the spreader and saw blade are not in alignment, adjustment is needed. To adjust:

- Unplug the saw then raise the blade guard assembly.
- Lift the anti-kickback pawls and place a framing square or straight edge against both the saw blade and the spreader.
- From the back of the saw, loosen the two screws and reposition the blade guard assembly left or right as needed to align the spreader with the saw blade.
- Once properly aligned, securely retighten the screws.
- Recheck the marked blade tooth using the combination square to insure the adjustment has not moved.

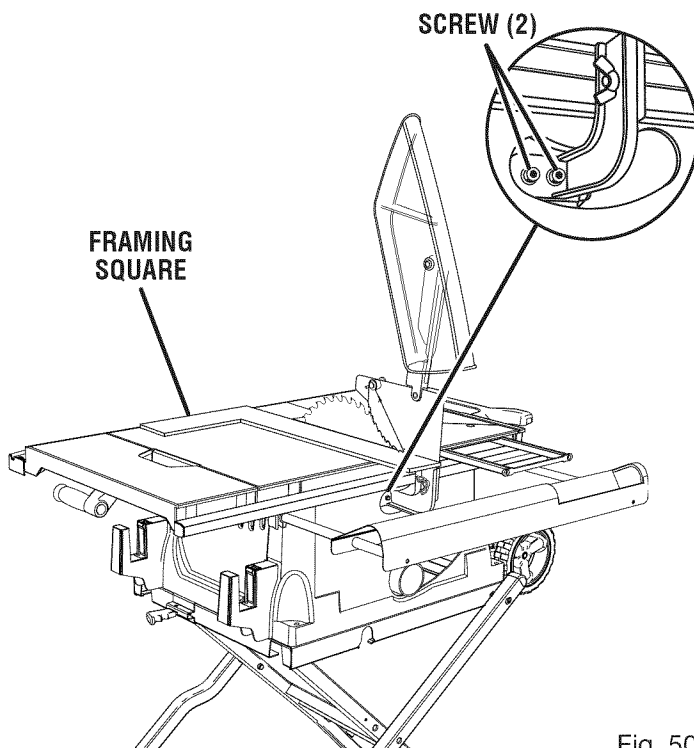

Fig. 50

TO CHECK THE ALIGNMENT OF THE RIP FENCE TO THE BLADE

See Figure 51.

- Unplug the saw.
- Raise the locking lever to permit the rip fence to be moved.
- Place a framing square beside the blade and move the rip fence up to the square. Take the dimension on the rip scale.
- Move the fence back and turn the framing square 180° to check the other side.

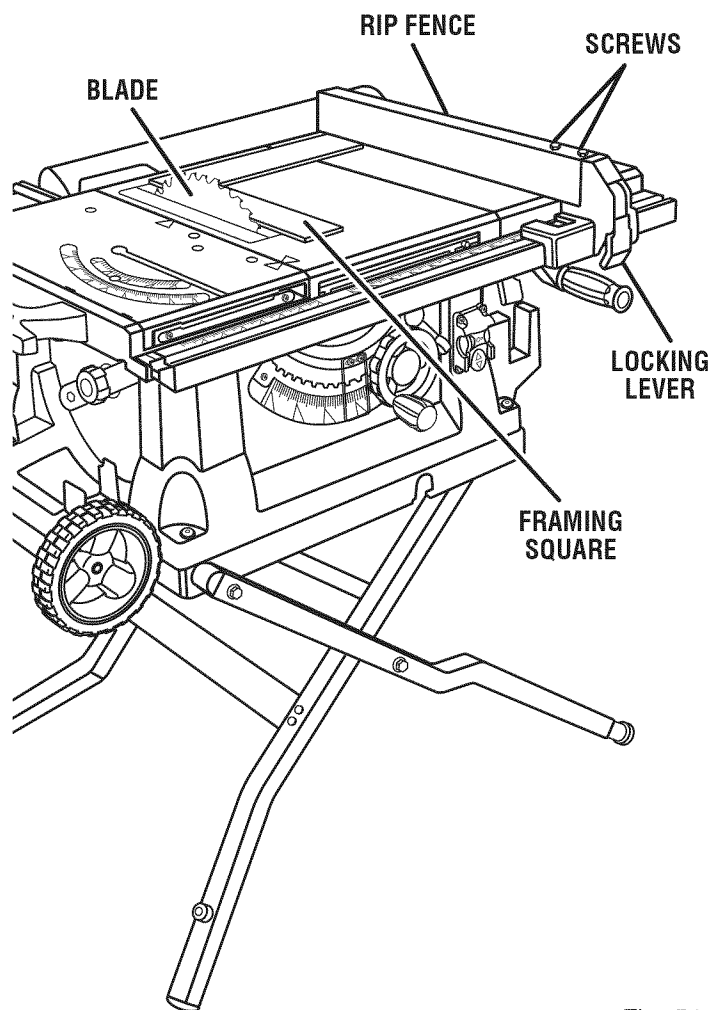

Fig. 51

ADJUSTMENTS

- If the two dimensions are not the same, loosen the two screws on the fence and align it.
- Retighten the two screws.
- Make two or three test cuts on scrap wood. If the cuts are not true, repeat the process.

⚠ WARNING: Before plugging the saw back in to make test cuts, make sure the switch is in the **OFF** position and the blade guard is in place. Failure to do so can result in serious injury.

TO SET THE BLADE AT 0° AND 45°

See Figures 52 - 53.

The angle settings of the saw have been set at the factory and, unless damaged in shipping, should not require setting during assembly. After extensive use, it may need to be checked.

- Unplug the saw.
- Raise the blade and the blade guard.

If the blade is not perfectly vertical (0°):

- Loosen the adjustment bolt and the bevel locking lever.
- Place a combination square beside the blade on the left. Lock the angle by pushing the bevel locking lever and retighten the adjustment bolt.
- Turn the bevel handle until the bevel indicator points to zero. If the bevel handle is turned as far as possible and doesn't indicate zero properly, you may need to adjust the bevel indicator.

NOTE: It will be necessary to remove the bevel handle to adjust the bevel indicator.

If the blade is not an exact 45°:

- Loosen the adjustment bolt and the bevel locking lever.
- Place a combination square beside the blade on the left. Lock the angle by pushing the bevel locking lever and retighten the adjustment bolt.
- Turn the bevel handle until the bottom of the blade has moved completely to the left side of the slot. Lock the angle by pushing the bevel locking lever.
- If the blade is not an exact 45°, loosen the adjustment bolt and the bevel locking lever.
- Adjust the bevel indicator to 45°.
- Make a test cut.

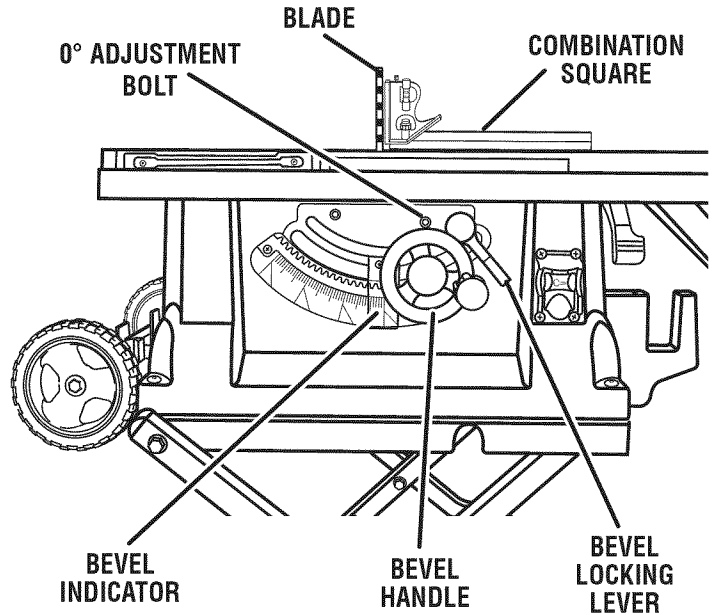

Fig. 52

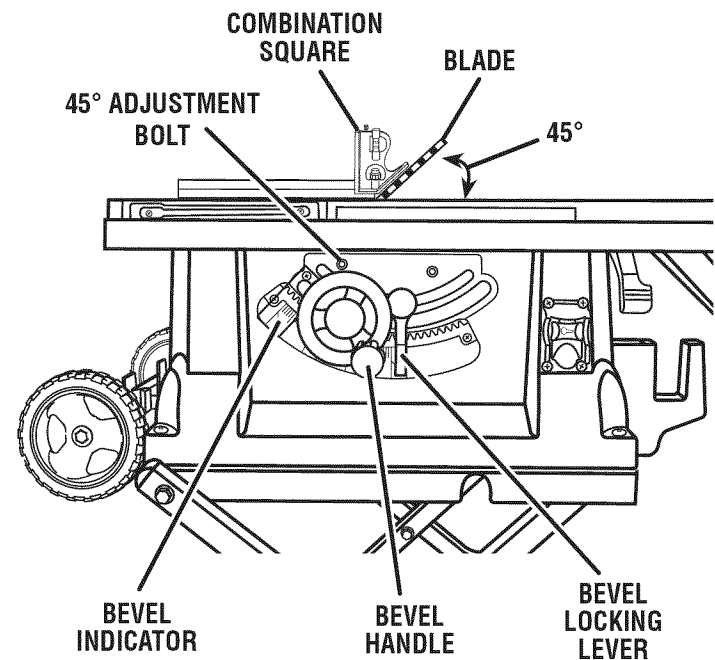





Fig. 53

MAINTENANCE

 **WARNING:** When servicing, use only identical replacement parts. Use of any other parts may create a hazard or cause product damage.

 **WARNING:** Always wear safety goggles or safety glasses with side shields during power tool operation or when blowing dust. If operation is dusty, also wear a dust mask.

 **WARNING:** Before performing any maintenance, make sure the tool is unplugged from the power supply and the switch is in the off (**O**) position. Failure to heed this warning could result in serious personal injury.

GENERAL

Avoid using solvents when cleaning plastic parts. Most plastics are susceptible to damage from various types of commercial solvents and may be damaged by their use. Use clean cloths to remove dirt, dust, oil, grease, etc.

 **WARNING:** Do not at any time let brake fluids, gasoline, petroleum-based products, penetrating oils, etc., come in contact with plastic parts. Chemicals can damage, weaken, or destroy plastic which may result in serious personal injury.

- Periodically check all clamps, nuts, bolts, screws, and belts for tightness and condition. Make sure the throat plate is in good condition and in position.
- Check the blade guard assembly.
- To maintain the table surfaces, fence, and rails, periodically apply paste wax to them and buff to provide smooth functioning. To prevent work from slipping during cutting operation, **Do not** wax the working face of the miter fence.
- Protect the blade by cleaning out saw dust from underneath the table and in the blade teeth. Use a resin solvent on the blade teeth.
- **Clean plastic parts only with a soft damp cloth. Do not** use any aerosol or petroleum solvents.

LUBRICATION

This saw has been lubricated at the factory prior to shipment. Following extended use, you should inspect and lubricate the following areas to assure smooth operation.

ACCESSORIES

The following recommended accessories are currently available at retail stores:

0134010313 Dado Throat Plate

 **WARNING:** Current attachments and accessories available for use with this tool are listed above. Do not use any attachments or accessories not recommended by the manufacturer of this tool. The use of attachments or accessories not recommended can result in serious personal injury.

TROUBLESHOOTING

PROBLEM	CAUSE	SOLUTION
Excess vibration.	Blade is out of balance.	Replace blade.
	Blade is damaged.	Replace blade.
	Saw is not mounted securely.	Tighten all hardware.
	Work surface is uneven.	Reposition on flat surface. Adjust legs of optional stand.
	Blade is warped.	Check saw blade installation. Replace blade if necessary.
Rip fence does not move smoothly.	Rip fence not mounted correctly.	Remount the rip fence.
	Rails are dirty or sticky.	Clean and wax rails.
	Clamp screw is out of adjustment.	Adjust clamp screw counterclockwise.
Rip fence does not lock at rear.	Clamp screw is out of adjustment.	Adjust clamp screw clockwise.
Cutting binds or burns work.	Blade is dull.	Replace or sharpen blade.
	Work is fed too fast.	Slow the feed rate.
	Rip fence is misaligned.	Align the rip fence.
	Wood is warped.	Replace the wood. Always cut with convex side to table surface.
	Rip fence is misaligned.	Check and adjust the rip fence.
Wood edges away from rip fence when ripping.	Blade not properly sharpened or set.	Resharpener or set blade.
Sliding miter table assembly does not move smoothly.	Miter base or slides improperly adjusted.	See page 23 for adjustments to sliding miter table assembly.

TROUBLESHOOTING

PROBLEM	CAUSE	SOLUTION
Saw does not make accurate 90° or 45° cuts.	Positive stops inside cabinet need adjusting (Bevel Cuts).	Adjust positive stops.
	Miter gauge is misaligned (Miter Cuts).	Adjust the miter gauge.
Height/bevel adjusting hand-wheel is hard to turn.	Gears or screw post inside cabinet are clogged with saw dust.	Clean the gears or screw post.
Saw does not start.	Motor cord or wall cord is not plugged in.	Plug in motor cord or wall cord.
	Circuit fuse is blown.	Replace circuit fuse.
	Circuit breaker is tripped.	Reset circuit breaker.
	Cord or switch is damaged.	Have the cord or switch replaced at your Sears Service Center/Department.
Blade makes poor cuts.	Blade is dull or dirty.	Clean, sharpen, or replace blade.
	Blade is wrong type for cut being made.	Replace with correct type.
	Blade is mounted backwards.	Remount blade.
Blade does not lower when turning height/bevel adjusting handwheel.	Locking lever is not at full left position.	Move locking lever to left.
Motor labors in rip cut.	Blade not proper for rip cut.	Change blade; rip blade typically has fewer teeth.

CRAFTSMAN 10 in. TABLE SAW – MODEL NO. 315.218061

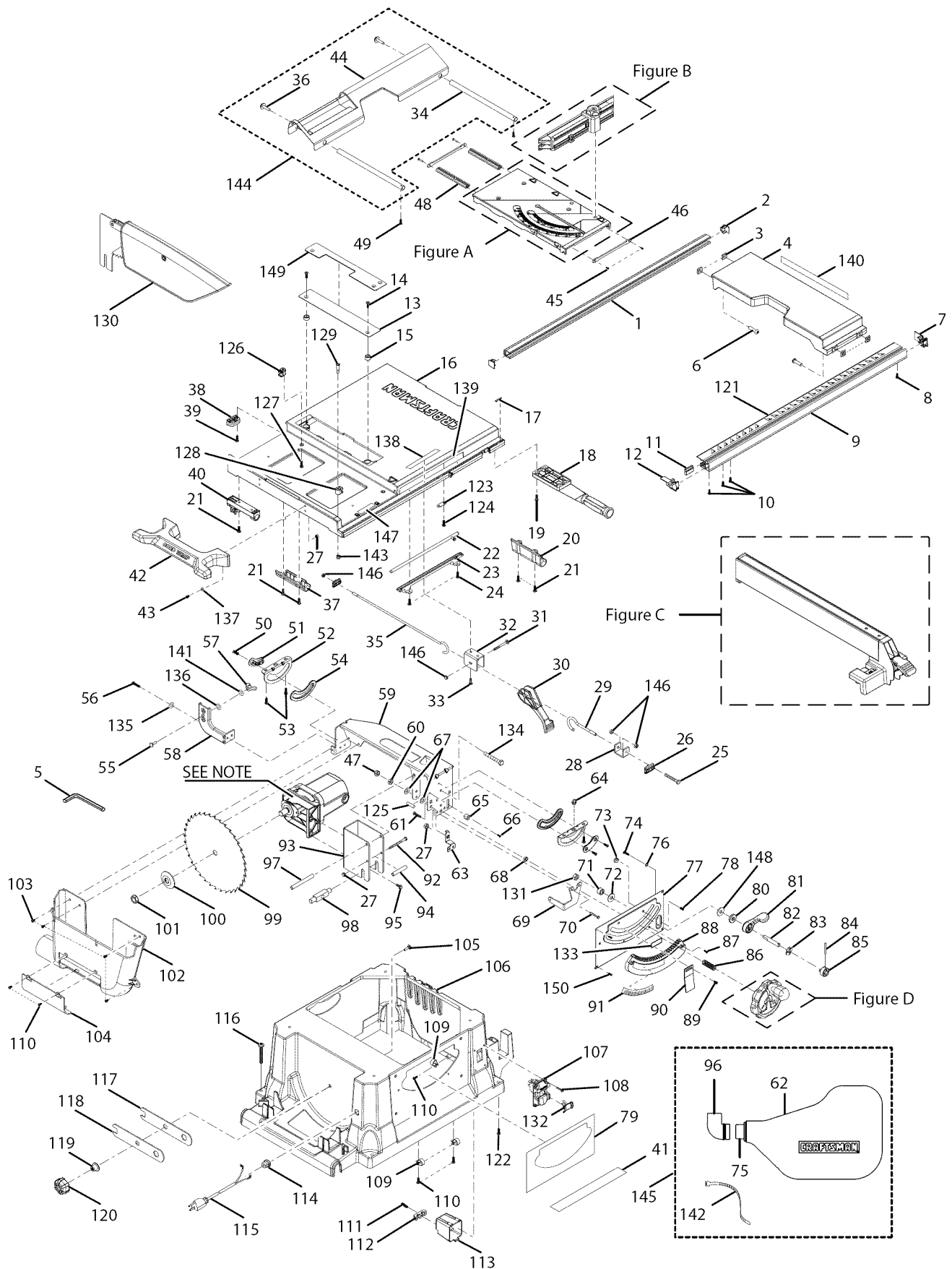

NOTE: The assembly shown represents an important part of the double insulated system. To avoid the possibility of alteration or damage to the system, service should be performed by your nearest Sears Repair Center. Contact your nearest Sears retail store for service center information.

CRAFTSMAN 10 in. TABLE SAW – MODEL NO. 315.218061

The model number will be found on a plate attached to the motor housing. Always mention the model number in all correspondence regarding your **Table Saw** or when ordering repair parts.

PARTS LIST

Key No.	Part Number	Description	Qty.	Key No.	Part Number	Description	Qty.
1	0134011803	Rear Rail.....	1	40	0121010214	Extension Bracket.....	2
2	0134010211	End Cap, Rear Rail.....	2	41	9134015330203	Warning Label.....	1
3	0134010308	Rail Holder Nut.....	4	42	0134010237-130	Cord Wrap.....	1
4	0134010103-126	Extension Table.....	1	43	410251020	Screw (M6 x 15 mm, Pan Hd.)..	4
5	0101140903	Hex Key (M5 x 75 mm).....	1	44	0134010322-58	Outfeed Support.....	1
6	410371002	Screw (M6 x 15 mm, Hex Hd.)..	4	45	410201005	Screw (M4 x 12 mm, Flat Hd.) ..	4
7	0134010212	End Cap, Right Front Rail	1	46	0134010314	Bar, Sliding Miter Table	2
8	410561014	Screw (M4 x 5 mm).....	1	47	411071707	Lock Nut (1/4-20).....	1
9	0134011802	Front Rail	1	48	0134011804	Sliding Bar.....	2
10	410561004	Screw (M4 x 12 mm, Pan Hd.) ..	3	49	410192001	Screw (M4 x 10 mm).....	2
11	0134010242	Stopper, Front Rail.....	1	50	410109008	Screw (M5 x 12 mm, Pan Hd.)..	4
12	0134010219	Indicator, Extended Table	1	51	0134010220	Slider.....	2
13	0134010307-129	Throat Plate.....	1	52	0134010315	Bracket.....	2
14	410101005	Screw (M5 x 15 mm, Flat Hd.) ..	2	53	410371003	Screw w/Washer (M6 x 12 mm)	4
15	0121011301	Pad, Throat Plate	2	54	0134010215	Slider.....	2
16	0134010102-126	Main Table.....	1	55	410031014	Carriage Bolt (M8 x 15 mm).....	1
17	0134010213	Slider.....	5	56	410341006	Screw w/Washer (M6 x 12 mm)	2
18	0131020220	Table Tilt Handle	1	57	411171003	Wing Nut (M8)	1
19	0131010814	Screw (10-24 x 25 mm, Hex Hd.).....	4	58	0134010319	Bracket, Riving Knife	1
20	0131010229	Carry Handle.....	1	59	0134010321	Pivot Bracket	1
21	410171706	Screw (10-24 x 1/2 in.).....	8	60	411011707	Hex Nut (1/4-20)	1
22	0134010911	Miter Table Latch	1	61	410291006	Screw w/Washer (M8 x 10 mm)	1
23	0134010210	Guide	1	62	0134015001	Dust Bag	1
24	410171721	Screw (8-32 x 3/8 in.).....	2	63	0134010317	Indicator Bracket	1
25	410011013	Screw (M6 x 40 mm, Hex Hd.)..	1	64	0121010901	Eccentric Shaft.....	1
26	0134010206	Locking Block	2	65	0134010503	Plate.....	1
27	411061001	Lock Nut (M6)	3	66	410109019	Screw (M6 x 20 mm, Flat Hd.) ..	1
28	0134010332	Adjusting Plate.....	1	67	412011701	Washer (1/4 x 16 x 1T)	2
29	0134010902	Linkage, Short.....	1	68	0101010908	Nut, Special	1
30	0134010229	Table Extension Lever.....	1	69	0134010305	Support Bracket.....	1
31	410031002	Carriage Bolt (M6 x 40 mm).....	1	70	410291004	Screw w/Washer (M6 x 10 mm).....	2
32	0134010306	Bracket.....	1	71	0134010236	Locking Ring.....	1
33	410251017	Screw w/Washer (M6 x 12 mm).....	2	72	412011117	Washer (M10 x 23 x 2T)	1
34	0134010916	Guide Rod.....	2	73	0134010339	Cam	2
35	0134010903	Linkage, Long	1	74	410134005	Screw (M4 x 5 mm, Pan Hd.)....	2
36	410551701	Screw w/Washer (1/4-20 x 1/2 in.).....	2	75	0181010246	Adaptor	1
37	0134010209	Handle, Left.....	1	76	412042002	Washer (D4).....	2
38	0134010223	Holder, Rear Rail	3	77	0134010320	Support Plate, Front Cabinet....	1
39	410351003	Screw w/Washer (M6 x 25 mm, Hex Hd.).....	6	78	410499007	Screw (M5 x 8 mm, Truss Hd.)..	2
				79	089110115900	Name Plate	1
				80	0134011301	Rubber Pad.....	1

CRAFTSMAN 10 in. TABLE SAW – MODEL NO. 315.218061

The model number will be found on a plate attached to the motor housing. Always mention the model number in all correspondence regarding your **Table Saw** or when ordering repair parts.

PARTS LIST

Key No.	Part Number	Description	Qty.	Key No.	Part Number	Description	Qty.
81	0134010230	Bevel Locking Lever	1	116	410491006	Screw (M8 x 40 mm, Hex Hd.)	4
82	0134010912	Screw (SS41)	1	117	0131010318	Blade Wrench (Small)	1
83	0134010316	Shim.....	1	118	0134010331	Blade Wrench (Large)	1
84	410138743	Screw (8-32 x 1 in., Pan Hd.)...	1	119	0134010238	Ring, Knob	1
85	0134010224	Cam, Bevel Locking Lever.....	1	120	0121010221	Knob	1
86	0101010907	Compression Spring.....	1	121	9134015330301	Scale Label	1
87	0000120817	Screw (8-16 x 19.05 mm)	2	122	410161010	Hex Screw (M6 x 25 mm)	5
88	0134010228	Gear Rack.....	1	123	0134010304	Shim.....	1
89	410331010	Screw w/Washer (M5 x 8 mm Pan Hd.).....	2	124	410171706	Screw (10-24 x 1/2 in. Pan Hd.).....	14
90	0134010233	Indicator, Bevel Angle.....	1	125	0134010906	Spacer	2
91	9134015330102	Label, Bevel Angle.	1	126	013401216	Hook	3
92	410011027	Screw (M6 x 70 mm, Hex Hd.)	1	127	410561013	Screw (M5 x 16 mm, Pan Hd.)	3
93	0134010318	Motor Bracket.....	1	128	0134010214	Adjusting Hook	1
94	0134010907	Spacer	1	129	0134010801	Adjusting Screw	1
95	410161001	Screw (M6 x 15 mm, Hex Hd.).....	3	130	A134011001	Blade Guard Assembly	1
96	0181010247	Elbow.....	1	131	411071004	Lock Nut (M10)	1
97	414011002	Pin (D8 x 90 mm)	1	132	0121010232	Safety Key	1
98	0121010902	Slider.....	1	133	9134015330103	Blade Angle Label.....	1
99	422010045	*** Blade (10 in. x 36T).....	1	134	410011024	Hex Screw (M6 x 110 mm)	2
100	0101010302	Blade Washer	1	135	412011741	Washer (6.5 x 13 x 1.5T)	2
101	0181010804	Arbor Nut (5/8-18).....	1	136	412011037	Washer (8.5 x 16 x 1.5T)	1
102	0134010225	Inner Dust Cover.....	1	137	412011028	Washer (D6 x D16 x 1.5T)	4
103	410331003	Screw w/Washer (M6 x 10 mm, Pan Hd.).....	3	138	9134015330302	Front Rail Label.....	1
104	0134010226	Dust Cover, Outer	1	139	9134015335706	Slide Table Label.....	1
105	410031710	Carriage Bolt (5/16-18 x 1/2 in.)	1	140	089110115901	Set-Up Label, Leg	1
106	0134010205-130	Cabinet	1	141	412041005	External Star Washer (D8).....	1
107	452070019	Switch w/Key.....	1	142	0181010261	Restrain Wire	1
108	410601001	Screw (M4 x 20 mm, Truss Hd.).....	4	143	411071003	Lock Nut (M5)	1
109	0301030202	Power Cord Clamp (5/16 in.) ...	3	144	A134013901	Outfeed Support Assembly (Inc. Key Nos. 34, 36 and 44)...	1
110	410561004	Screw (M4 x 12 mm, Pan Hd.)	5	145	A134012401	Dust Bag Assembly (Inc. Key Nos. 62, 75, 96 and 142)	1
111	00001201817	Screw (8-16 x 19.05 mm, Pan Hd.).....	3	146	411071001	Lock Nut (M6)	4
112	0131010210	Clamping Pad (Power Cord)....	1	147	9134015330201	Pinch Point Label.....	1
113	0131010209	Switch Box	1	148	412011074	Washer (D10 x D26 x 2T)	1
114	451010003	Strain Relief	1	149	0134010313	Dado Throat Plate (Not Shown).....	1
115	0134010701	Power Cord.....	1	150	410181001	Screw (M4 x 7 mm).....	4
					987000585	Operator's Manual	1

*** Available At Your Nearest Sears Catalog Order or Retail

CRAFTSMAN 10 in. TABLE SAW – MODEL NO. 315.218061

FIGURE A: SLIDING MITER TABLE

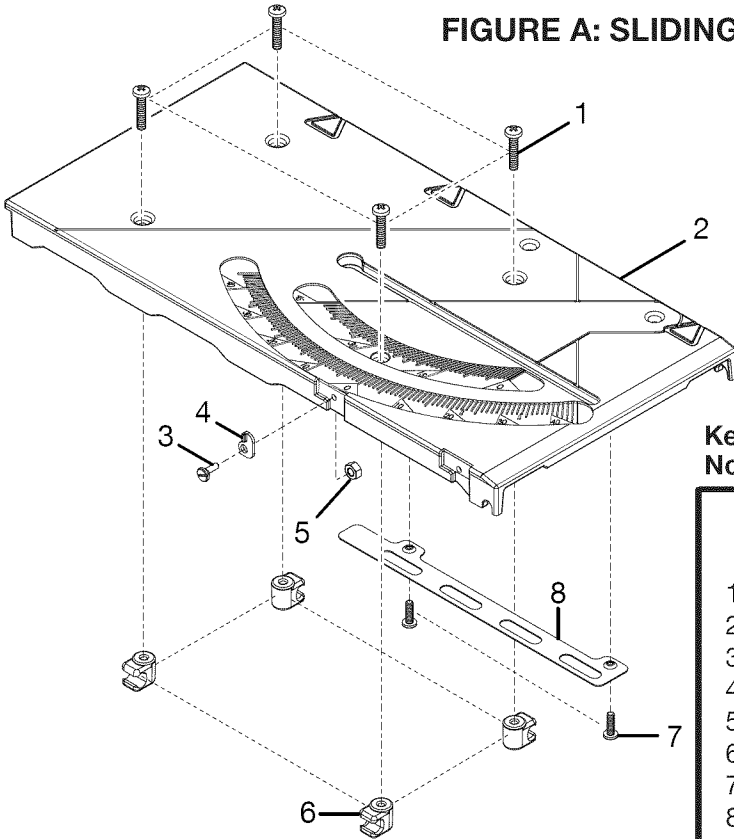

Key No.	Part Number	Description	Qty.
	A134010802	Sliding Miter Table Assembly (Inc. Key No. 1-8)	
1	410561013	Screw w/Washer (M5 x 16 mm)	4
2	0134010104-126	Miter Table.....	1
3	0134010910	Locking Pin	2
4	0181010501	Quick-Stop.....	2
5	0134010802	Locking Nut.....	2
6	0134010216	Hook.....	4
7	410181001	Screw (M4 x 7 mm)	2
8	0134010309	Supporting Plate	1

FIGURE B: MITER FENCE

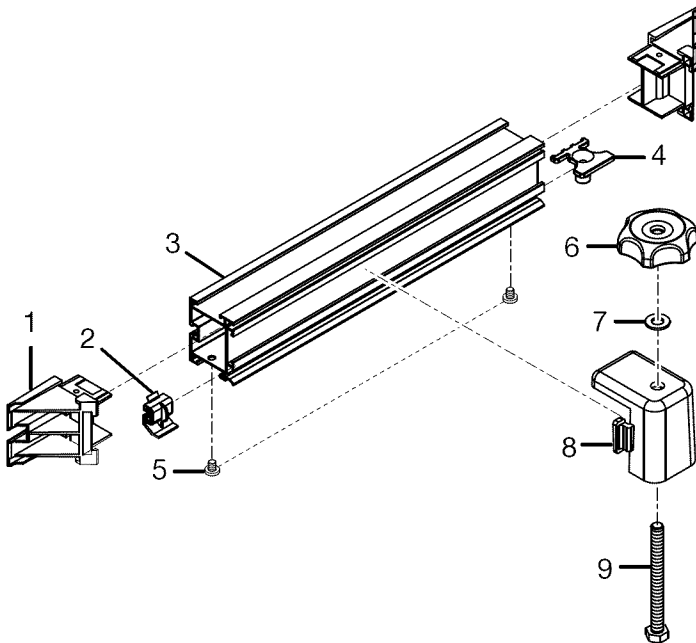

Key No.	Part Number	Description	Qty.
	A134010801	Miter Fence Assembly (Inc. Key No. 1-9)	
1	0134010227	End Cap	2
2	0181010208-58	Indicator	1
3	0134011801	Miter Fence	1
4	0134010244	Bracket.....	1
5	410451702	Screw (3/16 in., Pan Hd.)	2
6	0181110209	Adjusting Clamp Knob	1
7	412011051	Washer (8 x 16 x 1.5T).....	1
8	0181010210	Miter Fence Holder.....	1
9	410011717	Hex Screw (5/16-18 x 3-1/4 in.) ..	1

CRAFTSMAN 10 in. TABLE SAW – MODEL NO. 315.218061

FIGURE C: RIP FENCE

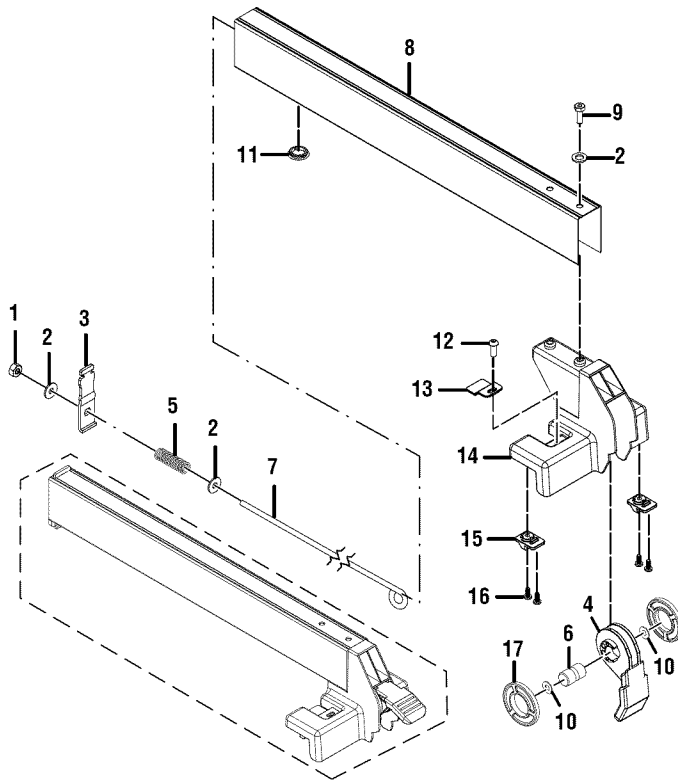

Key No.	Part Number	Description	Qty.
	A134010901	Rip Fence Assembly (Incl. Key No.1-17).....	1
1	411071001	Lock Nut (M6).....	1
2	412011030	Washer (6.5 x 16 x 1T).....	3
3	0121010310	Rear Clamping Plate	1
4	0134010231	Locking Lever.....	1
5	0121010915	Spring.....	1
6	0134010241	Axle	1
7	0134010904	Rod.....	1
8	0134011805	Rip Fence (506.2 mm)	1
9	410051001	Screw (M6 x 15 mm, Truss)....	2
10	412011115	Washer (16 x 25 x 1.5T).....	2
11	0121010209	Slider, Rip Fence	1
12	410331008	Screw w/Washer (M4 x 10 mm)	1
13	0134010232	Indicator	1
14	0134010105-126	Front Block.....	1
15	0134010218	Slider, Fence.....	2
16	410101713	Screw (8-32 x 8 mm, Flat Hd.)	4
17	0121010210	Round Pad	2

FIGURE D: HEIGHT ADJUSTING HANDWHEEL

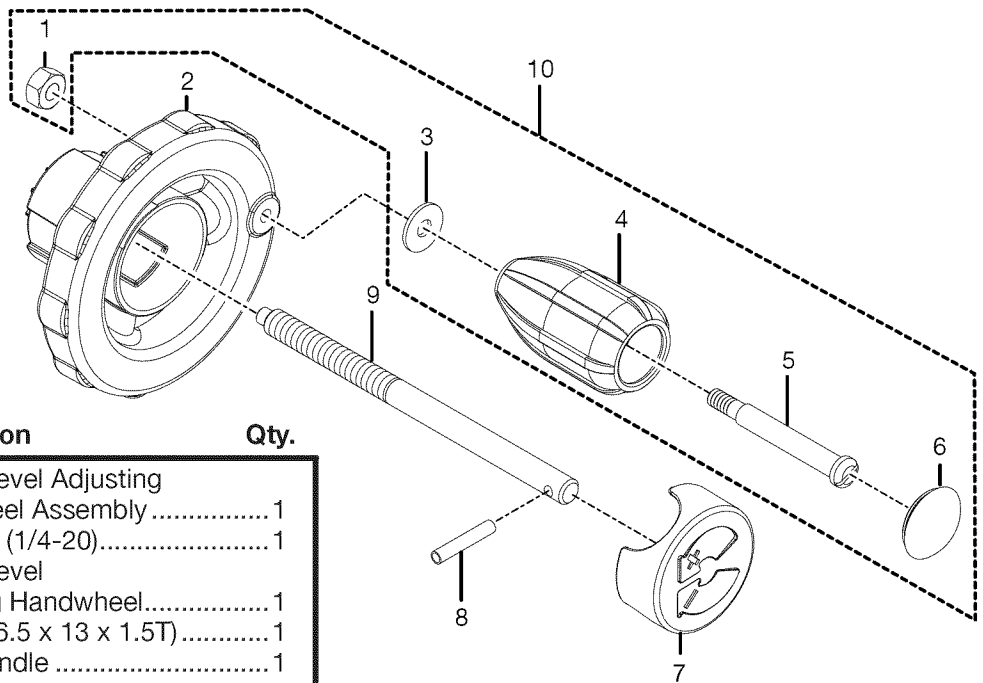

Key No.	Part Number	Description	Qty.
	A134014001	Height/Bevel Adjusting Handwheel Assembly	1
1	411072702	Lock Nut (1/4-20).....	1
2	0134010221-130	Height/Bevel Adjusting Handwheel.....	1
3	412012041	Washer (6.5 x 13 x 1.5T).....	1
4	0121010223	Bevel Handle	1
5	0101140203	Screw.....	1
6	0121010224	End Cap, Bevel Handle	1
7	0134010222	End Cap, Handwheel.....	1
8	414011003	Pin (4 x 20 mm).....	1
9	0134010905	Rod, Handwheel.....	1
10	A121015201	Bevel Handle Assembly (Incl. Key No. 1, 3-6)	1

CRAFTSMAN 10 in. TABLE SAW – MODEL NO. 315.218061

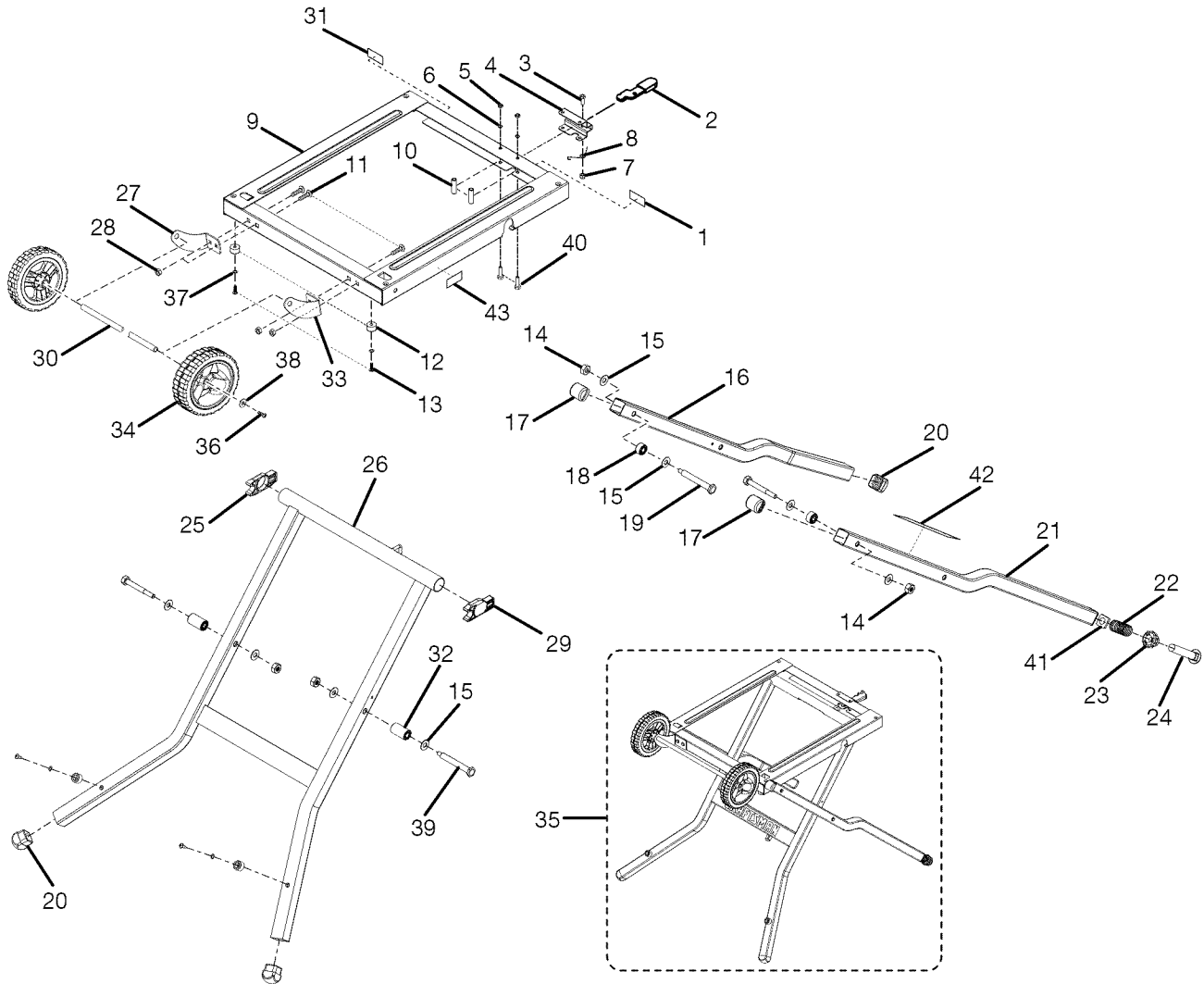

REPLACEMENT PARTS FOR LEG STAND ASSEMBLY

Key No.	Part Number	Description	Qty.	Key No.	Part Number	Description	Qty.
1	9134015335704	Unlock Label, Leg	1	23	0131010232	Adjusting Ring.....	1
2	089110114001	Latch Bar w/grommet	1	24	410031714	Bolt (5/8-11 x 88.9 mm)	1
3	0131010810	Screw	1	25	0131010230	Rear Slider, Leg.....	1
4	0131010323-82	Bracket.....	1	26	A134016303	Tube	1
5	411011707	Hex Nut (1/4 x 20)	2	27	0134010301	Bracket, Left	1
6	412041702	Washer (1/4 in.)	2	28	411061003	Nut (M8)	4
7	411071702	Nylon Nut (1/4 x 20)	1	29	0131010231	Front Slider, Leg.....	1
8	0131010915	Spring.....	1	30	0134010909	Axle	1
9	A134017001	Bracket Assembly, Leg	1	31	9134015335703	Lock Label, Leg	1
10	0131010923	Pin	2	32	0134010239	Spacer Tube, Leg.....	2
11	410031014	Carriage Bolt (M8 x 15 mm)	4	33	0134010302	Bracket, Right	1
12	0131011302	Pad.....	4	34	0134010245-130	Wheel	2
13	410451017	Screw (M6 x 18 mm)	4	35	A134011301	Leg Stand Assembly (Incl. Key No. 1-43)	1
14	0512010812	Nylon Nut (M10)	4	36	410611001	Screw/Washer (M6 x 15 mm)....	2
15	412011111	Washer (D10.3 x D27 x 2T)	12	37	412011025	Washer (6.5 x 10 x .8T)	4
16	0134010327-126	Rear Leg Support.....	1	38	412011744	Washer (6.5 x 20 x 1.6T)	2
17	0134010235	Upper End Cap, Leg	2	39	410011029	Hex Screw (M10 x 115 mm).....	2
18	0134010240	Spacer Tube.....	2	40	410011722	Hex Screw (1/4-20 x 50.8 mm).....	2
19	410011028	Screw (M10 x 105 mm, Hex Hd.).....	2	41	0182010319	Square Nut.....	1
20	0134010243	End Cap, Leg	3	42	089110115902	Tear Down Label	1
21	A134016301	Front Leg Support	1	43	9134015330202	Pinch Point Label.....	2
22	0131010918	Spring	1				