

Owner's Manual

CRAFTSMAN[®]

P R O F E S S I O N A L

3 in. BELT SANDER

Electronic Variable Speed / Dustless
Double Insulated

Model No.
315.277251

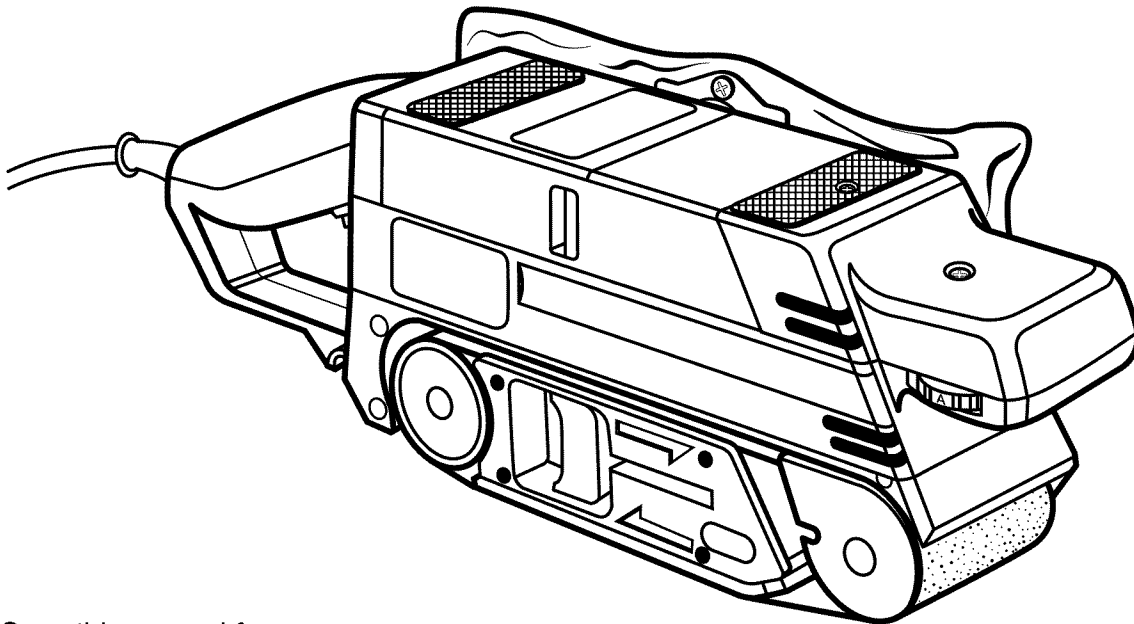

Save this manual for
future reference

⚠ CAUTION: Read and follow all Safety Rules and Operating Instructions before first use of this product.

Sears, Roebuck and Co., Hoffman Estates, IL 60179 USA



TABLE OF CONTENTS

| | |
|--|-------|
| ■ Table Of Contents | 2 |
| ■ Warranty and Introduction | 2 |
| ■ Rules For Safe Operation | 3-5 |
| ■ Product Specifications and Unpacking | 6 |
| ■ Features | 6-7 |
| ■ Adjustments | 8-10 |
| ■ Operation | 11-13 |
| ■ Maintenance | 14-17 |
| ■ Exploded View and Repair Parts List | 18-19 |
| ■ Parts Ordering / Service | 20 |

WARRANTY

FULL ONE YEAR WARRANTY ON CRAFTSMAN PROFESSIONAL BELT SANDER

If this **CRAFTSMAN** Professional Belt Sander fails due to a defect in material or workmanship within one year from the date of purchase, Sears will repair it, free of charge.

WARRANTY SERVICE IS AVAILABLE BY SIMPLY RETURNING THE TOOL TO THE NEAREST SEARS STORE OR SEARS SERVICE CENTER IN THE UNITED STATES.

This warranty gives you specific legal rights, and you may also have other rights which vary from state to state.

Sears, Roebuck and Co., Dept. 817WA, Hoffman Estates, IL 60179

INTRODUCTION

Your belt sander has many features for making sanding operations more pleasant and enjoyable. Safety, performance and dependability have been given top priority in the design of this sander making it easy to maintain and operate.

 **CAUTION:** Carefully read through this entire owner's manual before using your new belt sander. Pay close attention to the Rules For Safe Operation, Warnings and Cautions. If you use your belt sander properly and only for what it is intended, you will enjoy years of safe, reliable service.

GENERAL

Your Craftsman Professional Belt Sander is suitable for coarse, medium and fine sanding of wood, metals, plastics and other materials. It is ideal when used for smoothing rough boards, chamfering, rounding edges and many other general sanding applications. It is also an excellent tool for removing paint, varnishes, and stains. Its balanced design makes it easy to use.

RULES FOR SAFE OPERATION

The purpose of safety symbols is to attract your attention to possible dangers. The safety symbols, and the explanations with them, deserve your careful attention and understanding. The safety warnings do not by themselves eliminate any danger. The instructions or warnings they give are not substitutes for proper accident prevention measures.

SYMBOL MEANING



SAFETY ALERT SYMBOL:

Indicates caution or warning. May be used in conjunction with other symbols or pictographs.



DANGER: Failure to obey a safety warning will result in serious injury to yourself or to others. Always follow the safety precautions to reduce the risk of fire, electric shock and personal injury.



WARNING: Failure to obey a safety warning can result in serious injury to yourself or to others. Always follow the safety precautions to reduce the risk of fire, electric shock and personal injury.



CAUTION: Failure to obey a safety warning may result in property damage or personal injury to yourself or to others. Always follow the safety precautions to reduce the risk of fire, electric shock and personal injury.

NOTE: Advises you of information or instructions vital to the operation or maintenance of the equipment.

DOUBLE INSULATION

Double insulation is a concept in safety, in electric power tools which eliminates the need for the usual three-wire grounded power cord. All exposed metal parts are isolated from internal metal motor components with protecting insulation. Double insulated tools do not need to be grounded.

 **WARNING:** Do not attempt to operate this tool until you have read thoroughly and understand completely all instructions, safety rules, etc. contained in this manual. Failure to comply can result in accidents involving fire, electric shock, or serious personal injury. Save owner's manual and review frequently for continuing safe operation, and instructing others who may use this tool.

READ ALL INSTRUCTIONS

- **KNOW YOUR POWER TOOL.** Read owner's manual carefully. Learn its applications and limitations as well as the specific potential hazards related to this tool.
- **GUARD AGAINST ELECTRICAL SHOCK BY PREVENTING BODY CONTACT WITH GROUNDED SURFACES.** For example; pipes, radiators, ranges, refrigerator enclosures.
- **KEEP GUARDS IN PLACE AND IN WORKING ORDER.**

IMPORTANT

Servicing of a tool with double insulation requires extreme care and knowledge of the system and should be performed only by a qualified service technician. For service we suggest you return the tool to your nearest Sears Store for repair. Always use original factory replacement parts when servicing.

- **KEEP WORK AREA CLEAN.** Cluttered areas and benches invite accidents.
- **AVOID DANGEROUS ENVIRONMENT.** Don't use power tools in damp or wet locations or expose to rain. Keep work area well lit.
- **KEEP CHILDREN AND VISITORS AWAY.** All visitors should wear safety glasses and be kept a safe distance from work area. Do not let visitors contact tool or extension cord.
- **STORE IDLE TOOLS.** When not in use, tools should be stored in a dry and high or locked-up place – out of the reach of children.
- **DON'T FORCE TOOL.** It will do the job better and safer at the rate for which it was designed.
- **USE RIGHT TOOL.** Don't force small tool or attachment to do the job of a heavy duty tool. Don't use tool for purpose not intended – for example – A circular saw should never be used for cutting tree limbs or logs.

RULES FOR SAFE OPERATION (Continued)

- **WEAR PROPER APPAREL.** Do not wear loose clothing or jewelry that can get caught in tool's moving parts and cause personal injury. Rubber gloves and nonskid footwear are recommended when working outdoors. Wear protective hair covering to contain long hair and keep it from being drawn into nearby air vents.
- **ALWAYS WEAR SAFETY GLASSES.** Everyday eyeglasses have only impact-resistant lenses; they are **not** safety glasses.
- **PROTECT YOUR LUNGS.** Wear a face or dust mask if the operation is dusty.
- **PROTECT YOUR HEARING.** Wear hearing protection during extended periods of operation.
- **DON'T ABUSE CORD.** Never carry tool by cord or yank it to disconnect from receptacle. Keep cord from heat, oil, and sharp edges.
- **SECURE WORK.** Use clamps or a vise to hold work. It's safer than using your hand and it frees both hands to operate tool.
- **DON'T OVERREACH.** Keep proper footing and balance at all times. Do not use while standing on a ladder or unstable support. Secure tools when working at elevated positions.
- **MAINTAIN TOOLS WITH CARE.** Keep tools sharp and clean for best and safest performance. Follow instructions for lubricating and changing accessories.
- **DISCONNECT TOOLS.** When not in use, before servicing, or when changing or adjusting sanding belt, attachments, blades, bits, cutters, etc., all tools should be disconnected from power supply.
- **REMOVE ADJUSTING KEYS AND WRENCHES.** Form habit of checking to see that keys and adjusting wrenches are removed from tool before turning it on.
- **AVOID ACCIDENTAL STARTING.** Don't carry plugged-in tool with finger on switch. Be sure switch is off when plugging in.
- **MAKE SURE YOUR EXTENSION CORD IS IN GOOD CONDITION.** When using an extension cord, be sure to use one heavy enough to carry the current your product will draw. An undersized cord will cause a drop in line voltage resulting in loss of power and overheating. A wire gage size (A.W.G.) of at least 16 is recommended for an extension cord 100 feet or less in length. A cord exceeding 100 feet is not recommended. If in doubt, use the next heavier gage. The smaller the gage number, the heavier the cord.
- **OUTDOOR USE EXTENSION CORDS.** When tool is used outdoors, use only extension cords suitable for use outdoors. Outdoor approved cords are marked with the suffix W-A, for example - SJTW-A or SJOW-A.
- **NEVER USE THIS OR ANY POWER SANDER FOR WET SANDING.** Failure to comply can result in electrical shock causing serious injury or worse.
- **KEEP HANDS AWAY FROM SANDING AREA.**
- **NEVER USE IN AN EXPLOSIVE ATMOSPHERE.** Normal sparking of the motor could ignite fumes.
- **INSPECT TOOL CORDS PERIODICALLY** and if damaged, have repaired by authorized service facility. Stay constantly aware of cord location and keep it well away from the sanding area.
- **INSPECT EXTENSION CORDS PERIODICALLY** and replace if damaged.
- **KEEP HANDLES DRY, CLEAN, AND FREE FROM OIL AND GREASE.** Always use a clean cloth when cleaning. Never use brake fluids, gasoline, petroleum-based products, or any strong solvents to clean your tool.
- **STAY ALERT AND EXERCISE CONTROL.** Watch what you are doing and use common sense. Do not operate tool when you are tired. Do not rush.
- **CHECK DAMAGED PARTS.** Before further use of the tool, a guard or other part that is damaged should be carefully checked to determine that it will operate properly and perform its intended function. Check for alignment of moving parts, binding of moving parts, breakage of parts, mounting and any other conditions that may affect its operation. A guard or other part that is damaged should be properly repaired or replaced by an authorized service center.
- **DO NOT USE TOOL IF SWITCH DOES NOT TURN IT ON AND OFF.** Have defective switches replaced by an authorized service center.
- **INSPECT FOR** and remove all nails from lumber before sanding.

RULES FOR SAFE OPERATION (Continued)

- **DO NOT** operate this tool while under the influence of drugs, alcohol, or any medication.
- **DO NOT USE THIS SANDER FOR OVERHEAD SANDING.** Overhead sanding could result in dropping sander or loss of control. These situations could result in an accident resulting in possible serious injury.
- **POLARIZED PLUGS.** To reduce the risk of electric shock, this tool has a polarized plug (one blade is wider than the other). This plug will fit in a polarized outlet only one way. If the plug does not fit fully in the outlet, reverse the plug. If it still does not fit, contact a qualified electrician to install the proper outlet. Do not change the plug in any way.
- **WHEN SERVICING USE ONLY IDENTICAL CRAFTSMAN REPLACEMENT PARTS.**
- **SAVE THESE INSTRUCTIONS.** Refer to them frequently and use them to instruct others who may use this tool. If you loan someone this tool, loan them these instructions also.

⚠ WARNING: Some dust created by power sanding, sawing, grinding, drilling, and other construction activities contains chemicals known to cause cancer, birth defects or other reproductive harm. Some examples of these chemicals are:

- lead from lead-based paints,
- crystalline silica from bricks and cement and other masonry products, and
- arsenic and chromium from chemically-treated lumber.

Your risk from these exposures varies, depending on how often you do this type of work. To reduce your exposure to these chemicals, work in a well ventilated area and work with approved safety equipment, such as those dust masks that are specially designed to filter out microscopic particles.

⚠ Look for this symbol to point out important safety precautions. It means attention!!! Your safety is involved.

⚠ WARNING:



The operation of any belt sander can result in foreign objects being thrown into your eyes, which can result in severe eye damage. Before beginning power tool operation, always wear safety goggles or safety glasses with side shields and a full face shield when needed. We recommend Wide Vision Safety Mask for use over eyeglasses or standard safety glasses with side shields, available at Sears Retail Stores.

SAVE THESE INSTRUCTIONS

PRODUCT SPECIFICATIONS

| | | | |
|---------------|----------------------|----------------|----------------|
| Input | 6.0 Amperes | Belt Size | 3 in. x 21 in. |
| Rating | 120 volts, 60 Hz, AC | Overall Length | 17 in. |
| No Load Speed | 775 - 1,150 ft./min. | Net Weight | 8 lbs. |

UNPACKING

Your belt sander has been shipped completely assembled except for the sanding belt and dust bag. Inspect it carefully to make sure no breakage or damage has occurred during shipping. If any parts are damaged or missing, contact your nearest Sears Retail Store to obtain replacement parts before attempting to operate sander. Loose parts in carton will be a 3 in. x 21 in. sanding belt, dust bag and this owner's manual.

 **WARNING:** If any parts are missing, do not operate this tool until the missing parts are replaced. Failure to do so could result in possible serious personal injury.

FEATURES

KNOW YOUR BELT SANDER

See Figure 1.

Before attempting to use any tool, familiarize yourself with all operating features and safety requirements.

Features include easily operated electronic variable speed control dial; lock-on button; and dust bag for dustless sanding.

SWITCH

To turn your sander **ON**, depress the switch trigger. Release switch trigger to turn your sander **OFF**.

LOCK- ON BUTTON

The switch of your sander is equipped with a lock-on feature which is convenient when operating for extended periods of time. To lock-on, depress the trigger, push in the lock button located on the side of the handle, then while holding the lock button pushed in, release the trigger. To release the lock, depress the trigger and release.

ELECTRONIC VARIABLE SPEED CONTROL

Your belt sander has advanced electronic features, designed to assist you in getting the maximum use from your sander. By making proper speed selections, your sander can be adjusted to specific sanding needs.

VARIABLE SPEED

The variable speed control feature allows the sander to develop a no load speed that can be adjusted from 775 to 1,150 ft./min. by rotating the dial from **A** to **F**. The variable speed control dial is conveniently located on the side of the motor housing near the operator's hand.

DUST BAG

A dust bag is included with your sander to allow dustless sanding. Its use will help keep the work area clean.

FEATURES

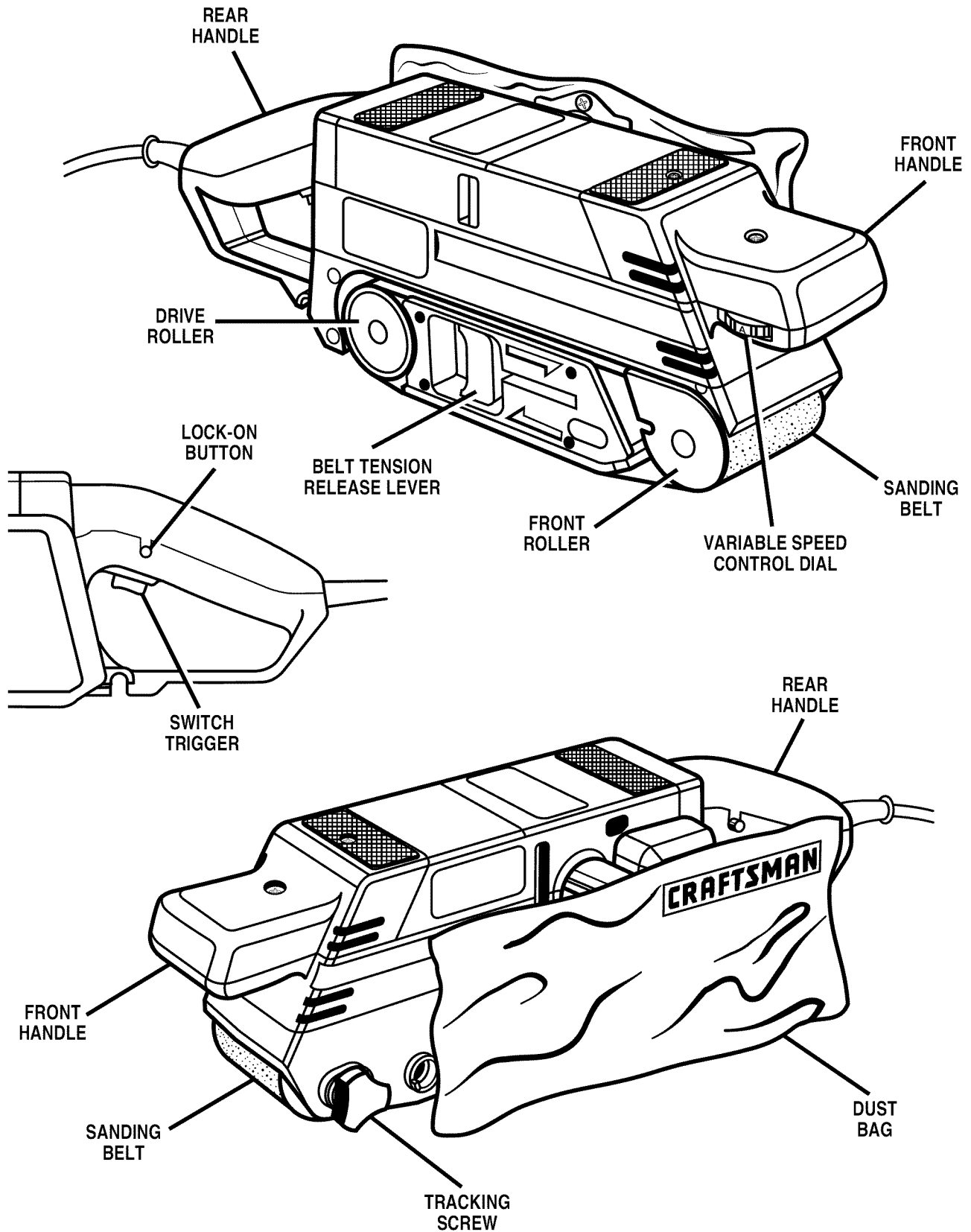

Fig. 1

⚠ WARNING: Do not allow familiarity with your sander to make you careless. Remember that a careless fraction of a second is sufficient to inflict severe injury.

ADJUSTMENTS

⚠ WARNING: Your sander should never be connected to power supply when you are assembling parts, changing belts, making adjustments, cleaning, or when not in use. Disconnecting your sander will prevent accidental starting that could cause serious personal injury.

DUST BAG

See Figure 2.

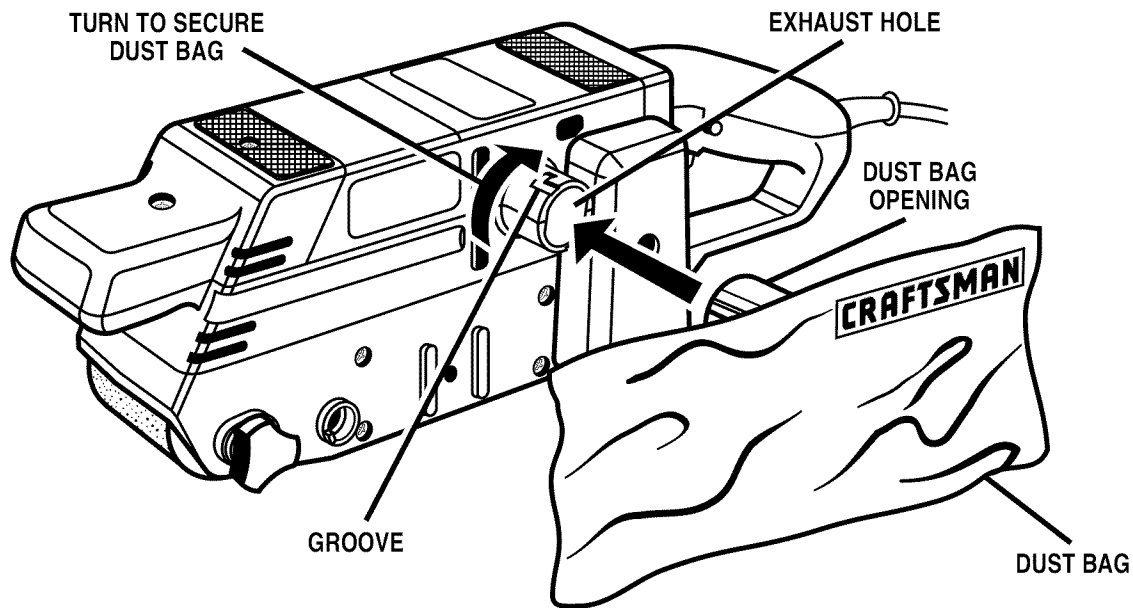

Fig. 2

The dust bag provides a dust collection system for your sander. It should be installed over the exhaust hole located on the side of your sander. For more efficient operation, empty dust bag when half full.

Do not connect sander to power supply before installing dust bag.

TO INSTALL/REMOVE DUST BAG

- Unplug your sander.

⚠ WARNING: Failure to unplug your sander could result in accidental starting causing possible serious personal injury.

- Place the opening of dust bag over exhaust hole of the sander aligning the notch inside opening of dust bag with groove on exhaust hole. The bag should be installed with the zipper down when sander is in upright position.
- Turn the dust bag clockwise to secure in place.
- To remove the dust bag, turn counterclockwise and pull off.

ELECTRICAL CONNECTION

Your belt sander has a precision built electric motor. It should be connected to a **power supply that is 120 volts, 60 Hz, AC only (normal household current)**. Do not operate this tool on direct current (DC). A substantial voltage drop will cause a loss of power and the motor will overheat. If your sander does not operate when plugged into an outlet, double-check the power supply.

TO EMPTY DUST BAG

Remove dust bag from sander, open zipper and shake out dust.

⚠ WARNING: To prevent the possibility of sawdust or foreign objects being thrown into your face and eyes, never attempt to use your sander without dust bag properly installed. Sawdust or foreign objects being thrown into your face and eyes could result in possible serious injury.

SANDING BELT SELECTION

Selecting the correct size and type of sanding belt is an important step in achieving a high quality sanded finish. Standard 3 in. x 21 in. sanding belts made of aluminum oxide, silicone carbide, and other synthetic abrasives are best for power sanding. In general, coarse grit will remove the most material and fine grit will produce the smoothest finish in all sanding operations. The condition of the surface to be sanded will determine which grit belt will do the job. If the surface is rough, start with a coarse grit belt sanding until surface is uniform. Medium grit belt may then be used to remove scratches left by the coarser belt and fine grit belt used for finishing of the surface. Always continue sanding with each grit belt until the surface is uniform.

ADJUSTMENTS

INSTALLING/REMOVING SANDING BELT

- Unplug your sander.

⚠ WARNING: Failure to unplug your sander could result in accidental starting causing possible serious personal injury.

- Position sander as shown in figure 3.

⚠ WARNING: Keep hands and fingers clear of front roller and spring mechanism at all times. Failure to do so could result in them getting pinched, causing possible serious injury.

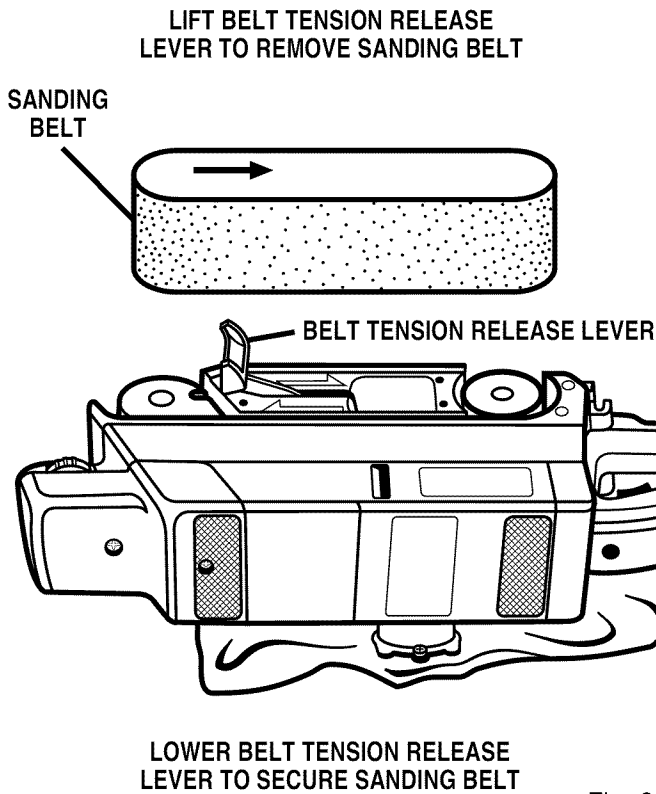

Fig. 3

Belt tension must be released in order to install and remove sanding belt:

- Release belt tension by lifting tension release lever as shown in figure 3.

- Install sanding belt making sure arrow inside of belt is pointing in the direction of rotation, which is clockwise when looking into open side of sander.

NOTE: The arrow inside sanding belt indicates the belt's direction of rotation, while the direction of rotation of the drive roller indicates the sander's direction of rotation.

⚠ CAUTION: Sanding belts, with an arrow inside of belt, installed backwards can create a hazardous condition.

NOTE: If there is no arrow inside of sanding belt, then sanding belt cannot be installed backwards. See Figure 4.

SANDING BELTS WITH DIRECTION OF ROTATION ARROWS MUST BE INSTALLED CORRECTLY

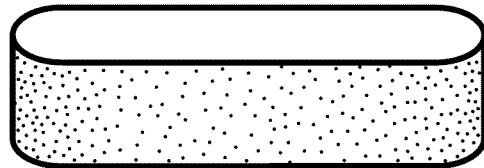
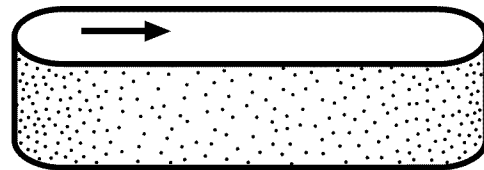

SANDING BELTS WITHOUT DIRECTION OF ROTATION ARROWS CAN BE USED IN EITHER DIRECTION

- Roughly align the belt to its correct position.
- Lower tension release lever to release tension on pulley and secure sanding belt.

Fig. 4

ADJUSTMENTS

TO ADJUST SANDING BELT TRACKING

⚠ WARNING: Before connecting your sander to power supply, always check to be sure it is not in lock-on position (depress and release switch trigger). Failure to do so could result in accidental starting of your sander resulting in possible serious injury. Also, do not lock the trigger on jobs where your sander may need to be stopped suddenly.

- Connect your sander to power supply.
- With sander positioned as shown in figure 5, pull switch trigger and release immediately.

⚠ WARNING: If sanding belt begins to wear excessively on the inner edge, readjust tracking screw. It is adjusted too far inward and the sanding belt is rubbing against internal parts.

- When you are sure the belt will not rub against internal parts, start your sander and fine adjust the tracking screw until the belt stabilizes.

When correctly adjusted, the outer edge of the belt will be even with the outer edge of the platen assembly. Belt life will be greatly increased if a few seconds are spent adjusting the belt tracking.

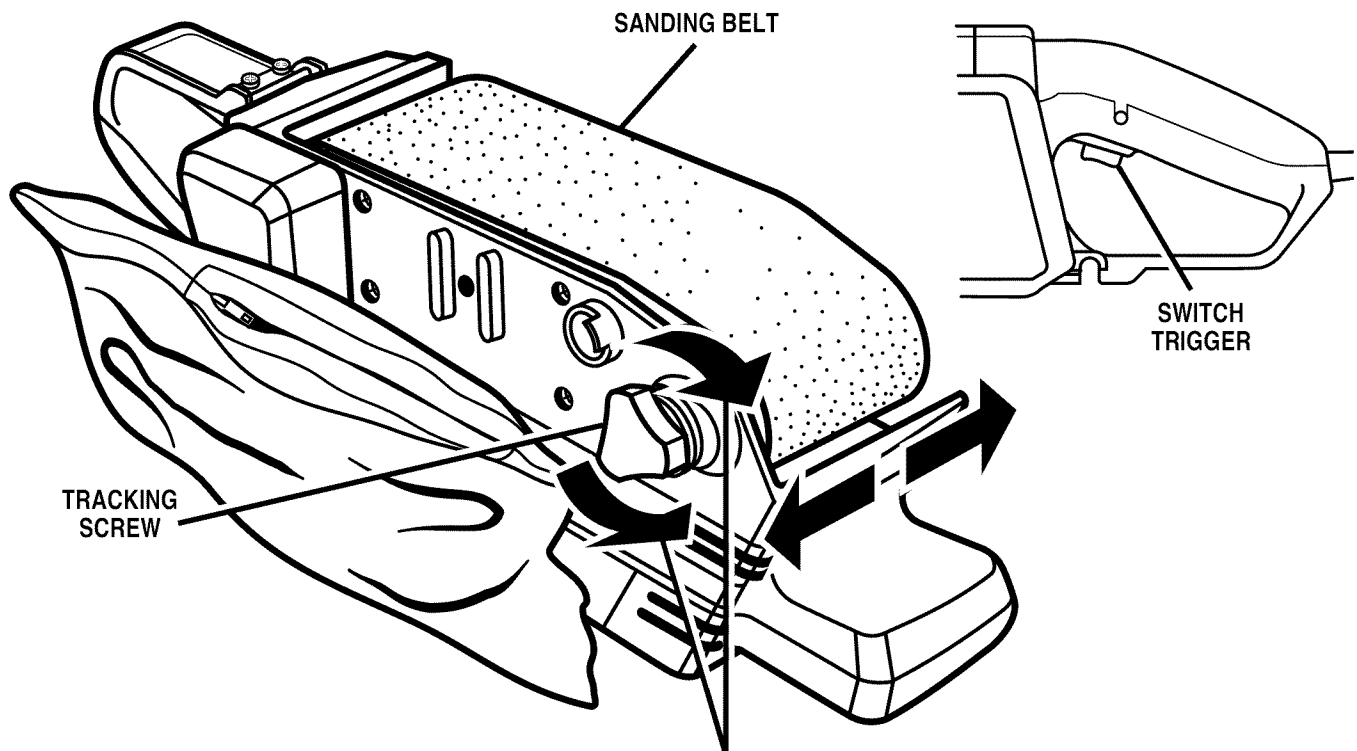

TURN TRACKING SCREW TO ADJUST SANDING BELT

Fig. 5

NOTE: This position is for adjustments only. Sanding belt should not be in contact with workpiece or any foreign objects when making belt tracking adjustments.

- Observe tracking of sanding belt. If the sanding belt runs inward, slowly turn the tracking screw clockwise. If the sanding belt runs outward, slowly turn the tracking screw counterclockwise. This should be done until you are sure belt will not run off sander, or come in contact with internal parts.

NOTE: After installing a new sanding belt, it may become necessary to change the adjustment several times until the belt becomes pliable.

⚠ WARNING: Keep hands and fingers away from moving sanding belt. Any part of body coming in contact with moving sanding belt could result in serious injury. Do not wear loose clothing or jewelry when operating sander. They could get caught in moving parts and foreign objects could get thrown away from sander causing injury.

IMPORTANT: Replace torn sanding belts immediately.

OPERATION

⚠ WARNING: Always wear safety goggles or safety glasses with side shields when operating your sander. Failure to do so could result in objects being thrown into your eyes, resulting in possible serious injury. If the sanding operation is dusty, also wear a face or dust mask.

APPLICATIONS

(Use only for the purpose listed below)

- Coarse, medium and fine sanding of wood, metals, plastics and other materials.
- Smoothing rough boards, chamfering, rounding edges and many other general sanding applications.
- Removing rust, paint, varnishes, and stains.

PREPARING FOR OPERATION

For ease of operation your sander has a front handle and a rear handle. These handles allow two-hand operation which aid in maintaining control, keeping sanding area level with workpiece, and keeping hands clear of sanding belt. When operating your sander always hold the front handle with your left hand and the rear handle with your right hand as shown in Figure 6.

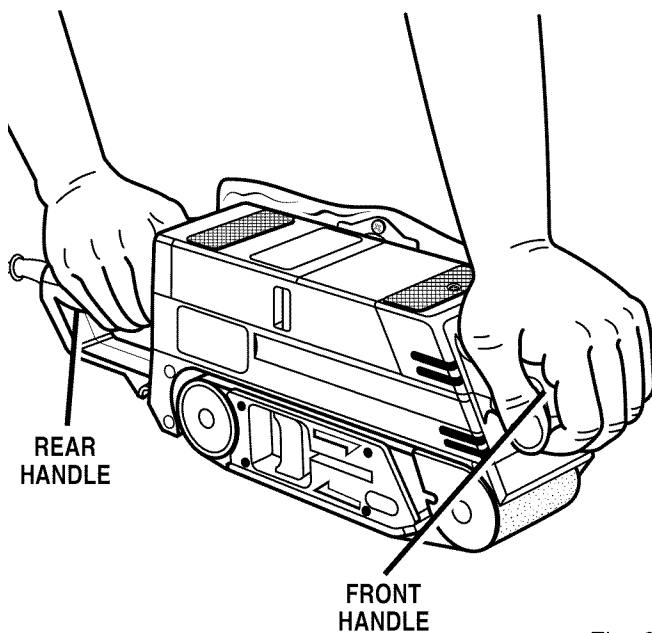
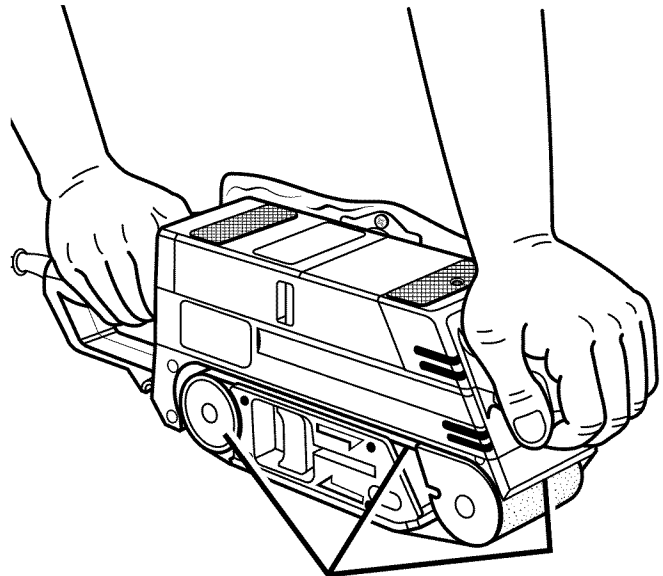

Fig. 6

⚠ WARNING: Keep hands and fingers clear of moving sanding belt, front pulley, and drive roller assembly. Failure to do so will result in the sanding of your hands or fingers. See Figure 7.



KEEP HANDS AND FINGERS AWAY FROM THESE AREAS AT ALL TIMES

Fig. 7

⚠ WARNING: Do not let your fingers rest over the front or right edge of the sander. If the sanding belt were to run off, or if it were not properly adjusted, your fingers could come in contact with the moving sanding belt resulting in possible serious injury. See Figure 7.

Always operate your sander as shown in Figure 6.

OPERATION

VARIABLE SPEED

See Figure 8.

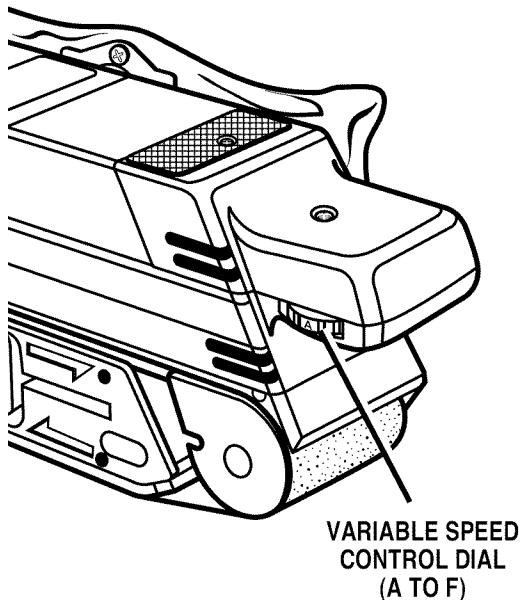

Fig. 8

Your sander has a variable speed control dial, **A** to **F**, designed to allow operator control of belt speed. To increase belt speed, turn the variable speed control dial to a higher setting. Turn to a lower setting to decrease belt speed. Refer to the chart on page 13 for proper speed selections.

SANDING

See Figure 9.

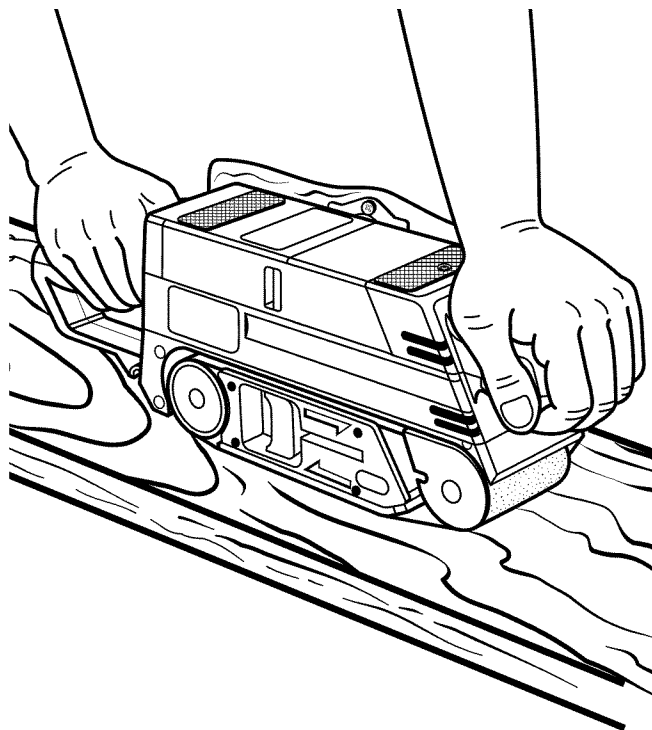

Fig. 9

Clamp or otherwise secure the work to prevent it from moving under your sander.

⚠ WARNING: Unsecured work could be thrown back toward operator causing injury.

Before placing sander on work surface, squeeze the switch trigger and let the motor reach its maximum speed, then lower your sander to the work surface with a slight forward motion. Using the rear handle to control your sander and the front handle only to guide it, move it slowly over the work. Allowing your sander to remain in one place will result in an uneven surface.

⚠ WARNING: Keep a firm grip on sander with both hands at all times. Failure to do so could result in loss of control leading to possible serious injury.

Your sander was designed to provide the proper weight on the sanding belt.

Excessive pressure will result in the following:

- Uneven work.
- Clogged sanding belts.
- Premature sanding belt wear. Removal rate will **not** increase.
- Possible motor burnout.
- Irregular sanding belt tracking.

NOTE: If the sanding belt moves while sanding, you may be applying too much pressure. When this occurs remove sander from workpiece. If belt tracking is properly adjusted, sanding belt will return to its normal and correct position on the drive roller and front roller.

Use a coarser belt when heavy sanding is desired, not heavy pressure. The importance of this cannot be over-emphasized. Weight has been built into the tool to give the most efficient pressure at the proper location.

NOTE: The front roller of your sander was not designed for contour sanding. Sanding on the front roller could cause irregularity in sanding belt tracking.

OPERATION

SETTING THE BELT SANDER SPEED

Refer to the chart below for belt sander speed selections.

| MATERIAL | SPEED | | | | | | BELT GRIT | | | | | |
|-------------------|-------|---|---|---|---|---|-----------|----|----|-----|-----|-----|
| | A | B | C | D | E | F | 40 | 60 | 80 | 100 | 150 | 240 |
| UNDRESSED TIMBER | | | | | * | * | ● | ● | | | | |
| SOFTWOOD | | * | | | | | | | | ● | ● | |
| CHIPBOARD | | | | * | * | | | ● | ● | | | |
| VENEER TIMBER | * | * | | | | | | | | | | ● |
| RUST REMOVAL | | | * | * | | | ● | ● | | | | |
| PAINTED SURFACE | | | | | * | * | ● | ● | | | | |
| NON FERROUS METAL | | | * | | | | | | ● | ● | | |

MAINTENANCE

⚠ WARNING: When servicing, use only identical Craftsman replacement parts. Use of any other part may create a hazard or cause product damage.

TIMING BELT REPLACEMENT

See Figures 10 and 11.

■ Unplug your sander.

⚠ WARNING: Failure to unplug your sander could result in accidental starting causing possible serious personal injury.

■ Remove dust bag.

■ Remove sanding belt from sander. Follow instructions on page 9 to remove sanding belt. **NOTE:** Removing sanding belt will simplify the process of installing a new timing belt.

■ Remove belt cover screw and belt cover. See Figure 10.

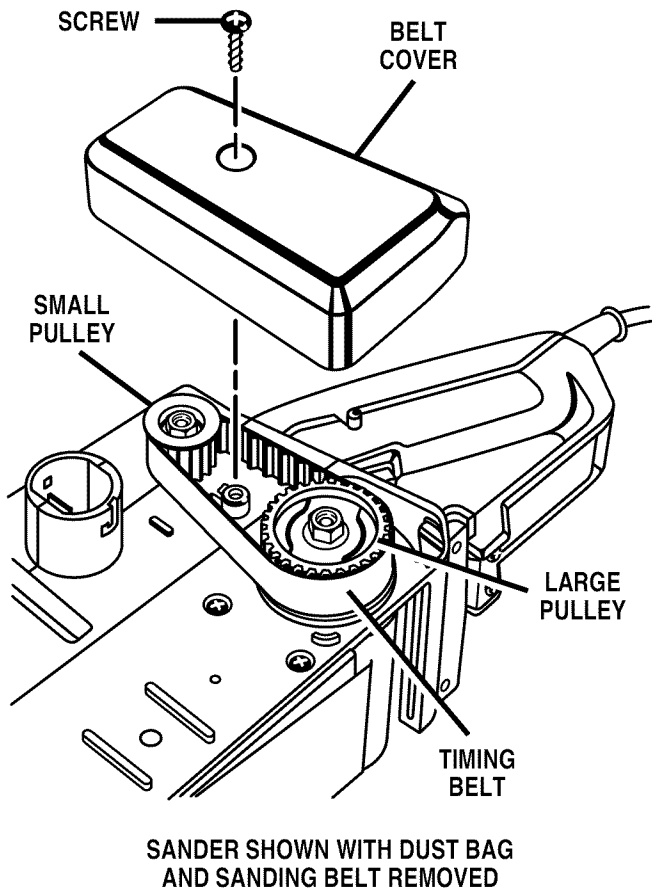

Fig. 10

- Force old timing belt from small pulley with a screwdriver and remove it from large pulley. If it is worn out, simply cut the old timing belt and remove.
- Install new timing belt over small pulley first.
- Holding the timing belt as shown in Figure 11, press belt onto the large pulley turning it as you press the belt on.

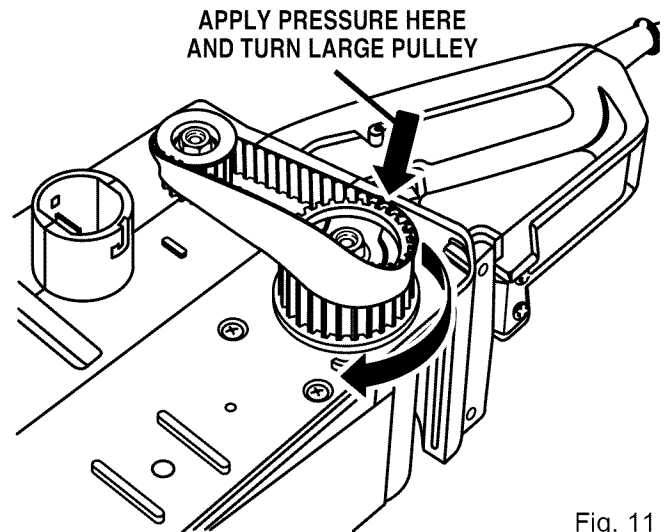

Fig. 11

- Reassemble belt cover and screw.
- Tighten screw securely.

⚠ WARNING: Never attempt to operate your belt sander without belt cover in place.

MAINTENANCE

SWITCH REPLACEMENT

See Figures 12 and 13.

- Unplug your sander.

⚠ WARNING: Failure to unplug your sander could result in accidental starting causing possible serious personal injury.

- Remove the handle cover screws and handle cover. Note the locations of all wiring in the handle and how each connection is made to the switch. Connections and wiring position must be identical when installing new switch. See Figure 12.

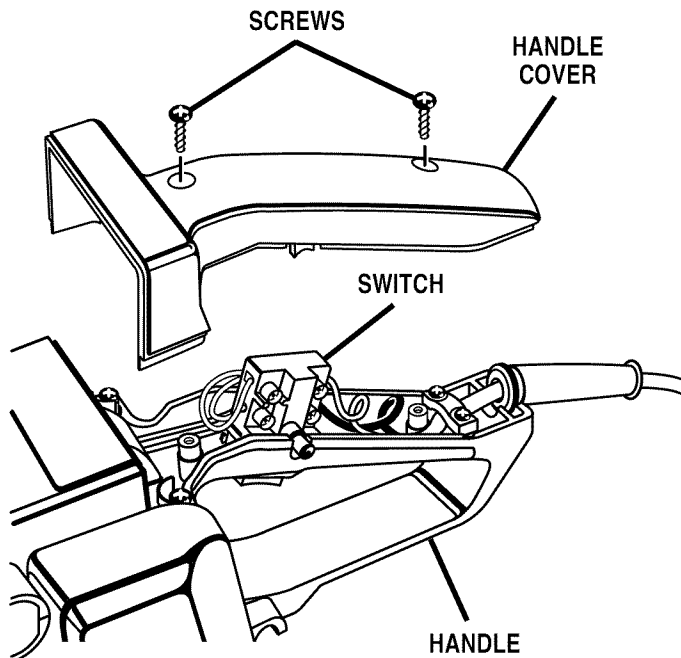

Fig. 12

- Lift the switch away from the handle.
- Using a small flat blade screwdriver, loosen the screw terminal for each switch lead. See Figure 13.

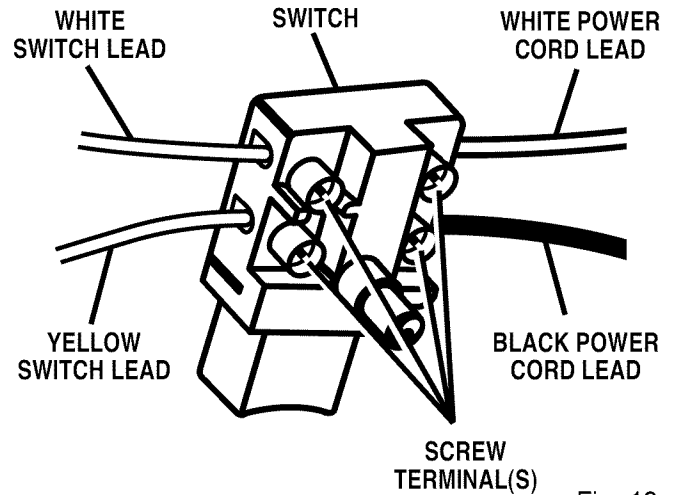

Fig. 13

- Once loose, switch leads can easily be removed from switch.
- Make lead connections to the new switch by inserting each lead into the screw terminals.
- Tighten each screw terminal securely.
- Pull on leads to check lead connections in terminals.
- Arrange the wiring in the handle so that it will not be pinched or contact screws when the handle cover and screws are replaced, then position the switch in place. See Figure 12.
- Replace handle cover and screws.
- Tighten handle cover screws securely.

MAINTENANCE

CORD REPLACEMENT

See Figures 14 and 15.

- Unplug your sander.

⚠ WARNING: Failure to unplug your sander could result in accidental starting causing possible serious personal injury.

- Remove the handle cover screws and handle cover. Note the locations of all wiring in the handle and how each connection is made to the switch. Connections and wiring position must be identical when installing new cord. See Figure 14.

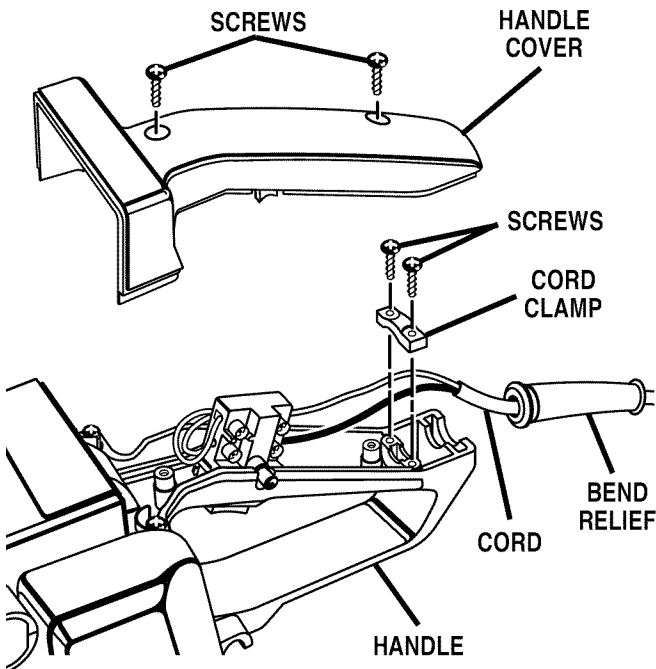

Fig. 14

- Remove the cord clamp screws and cord clamp.
- Remove the switch from the handle.
- Using a small flat blade screwdriver, loosen the screw terminal for each power cord lead. See Figure 15.

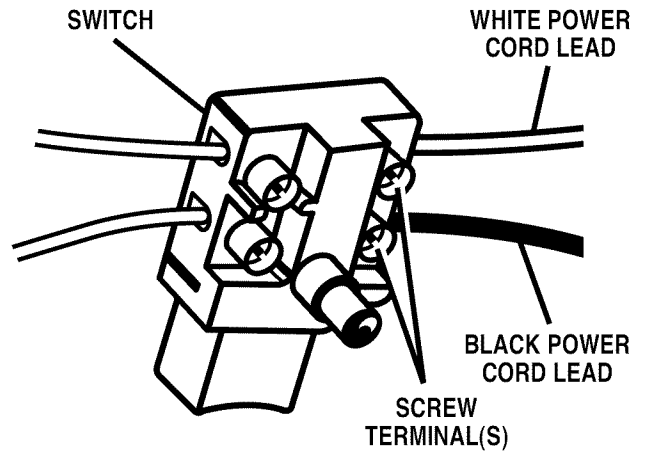

Fig. 15

- Once loose, power cord leads can easily be removed from switch.
- Remove bend relief from cord.
- Place bend relief on new cord.
- Make lead connections to the new cord by inserting each lead into the screw terminals.
- Tighten each screw terminal securely.
- Pull on leads to check lead connections in terminals.
- Arrange the wiring in the handle so that it will not be pinched or contact screws when the handle cover and screws are replaced. Position the switch in place. See Figure 14.
- Place the cord and bend relief in their correct locations. See Figure 12.
- Replace cord clamp and secure with cord clamp screws.
- Tighten cord clamp screws securely.
- Replace handle cover and screws.
- Tighten handle cover screws securely.

MAINTENANCE

GENERAL

Only the parts shown on parts list, page nineteen, are intended to be repaired or replaced by the customer. All other parts represent an important part of the double insulation system and should be serviced only by a qualified Sears service technician.

Avoid using solvents when cleaning plastic parts. Most plastics are susceptible to damage from various types of commercial solvents and may be damaged by their use. Use clean cloths to remove dirt, carbon dust, etc.

 **WARNING:** Do not at any time let brake fluids, gasoline, petroleum-based products, penetrating oils, etc. come in contact with plastic parts. They contain chemicals that can damage, weaken or destroy plastic.

It has been found that electric tools are subject to accelerated wear and possible premature failure when they are used on fiberglass boats, sports cars, wallboard, spackling compounds, or plaster. The chips and grindings from these materials are highly abrasive to electric tool parts such as bearings, brushes, commutators, etc. Consequently, it is not recommended that this tool be used for extended work on any fiberglass material, wallboard, spackling compounds, or plaster. During any use on these materials it is extremely important that the tool is cleaned frequently by blowing with an air jet.

LUBRICATION

All of the bearings in this tool are lubricated with a sufficient amount of high grade lubricant for the life of the unit under normal operating conditions. Therefore, no further lubrication is required.

EXTENSION CORDS

The use of any extension cord will cause some loss of power. To keep the loss to a minimum and to prevent tool overheating, use an extension cord that is heavy enough to carry the current the tool will draw.

A wire gage size (A.W.G.) of at least **16** is recommended for an extension cord 100 feet or less in length. When working outdoors, use an extension cord that is suitable for outdoor use. The cord's jacket will be marked **WA**.

 **CAUTION:** Keep extension cords away from the sanding area and position the cord so that it will not get caught on lumber, tools, etc., during sanding operation.

 **WARNING:** Check extension cords before each use. If damaged replace immediately. Never use tool with a damaged cord since touching the damaged area could cause electrical shock resulting in serious injury.

 **WARNING:** Always wear safety goggles or safety glasses with side shields during power tool operation or when blowing dust. If operation is dusty, also wear a dust mask.

CRAFTSMAN PROFESSIONAL 3 in. BELT SANDER

MODEL NUMBER 315.277251

SEE NOTE "A" PAGE 19

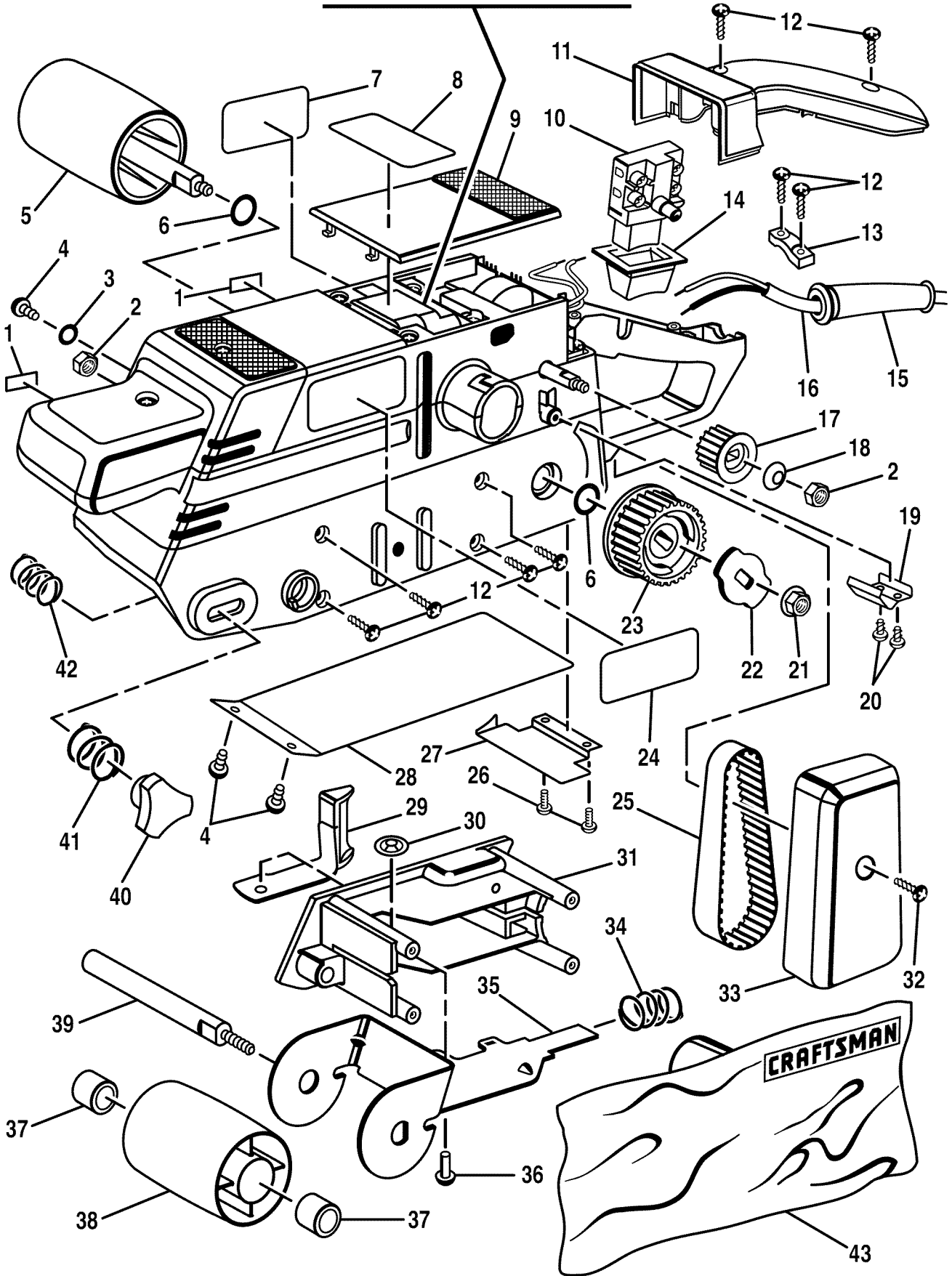

CRAFTSMAN PROFESSIONAL 3 in. BELT SANDER - MODEL NUMBER 315.277251

The model number will be found on a plate attached to the motor housing. Always mention the model number in all correspondence regarding your **BELT SANDER** or when ordering repair parts.

SEE BACK PAGE FOR PARTS ORDERING INSTRUCTIONS

PARTS LIST

| Key No. | Part Number | Description | Quan. |
|---------|-------------|---|-------|
| 1 | 069600-440 | Wear Strip | 2 |
| 2 | 093006-000 | * Hex Nut M6 | 2 |
| 3 | 095604-000 | Washer M4 | 1 |
| 4 | 090404-080 | * Screw (S) M4 x 18 | 3 |
| 5 | 976000-001 | Drive Roller Assembly | 1 |
| 6 | 069002-520 | Thrust Washer | 2 |
| 7 | 975646-001 | Logo Plate | 1 |
| 8 | 069203-120 | Speed Selection Chart | 1 |
| 9 | 975643-001 | Top Cover | 1 |
| 10 | 065501-380 | Switch Trigger | 1 |
| 11 | 975642-001 | Handle Cover | 1 |
| 12 | 090604-160 | * Screw (B) M4 x 16 | 8 |
| 13 | 065600-670 | Cord Clamp | 1 |
| 14 | 976855-001 | Switch Cover | 1 |
| 15 | 065601-310 | Bend Relief | 1 |
| 16 | 990495-008 | Power Cord | 1 |
| 17 | 068600-660 | Small Pulley | 1 |
| 18 | 095806-000 | Spring Washer M6 | 1 |
| 19 | 061801-300 | Spring Plate | 1 |
| 20 | 090604-100 | * Screw (B) M4 x 10 | 2 |
| 21 | 061309-630 | * Hex Nut M6 | 1 |
| 22 | 061507-940 | Lock Plate | 1 |
| 23 | 068600-670 | Large Pulley | 1 |
| 24 | 976854-001 | Data Plate | 1 |
| 25 | 068600-690 | Timing Belt | 1 |
| 26 | 976857-001 | * Screw (M4 x 8) | 2 |
| 27 | 976856-001 | Roller Guard | 1 |
| 28 | 061507-730 | Wear Plate | 1 |
| 29 | 975648-001 | Lever | 1 |
| 30 | 061301-880 | Push Nut | 1 |
| 31 | 975644-001 | Front Roller Case | 1 |
| 32 | 090605-200 | * Screw (B) M5 x 20 | 1 |
| 33 | 068804-590 | Belt Cover | 1 |
| 34 | 061801-240 | Coil Spring | 1 |
| 35 | 061507-820 | Yoke | 1 |
| 36 | 061202-800 | Rivet 5 x 12 | 1 |
| 37 | 067600-430 | Sleeve Bearing | 2 |
| 38 | 030604-080 | Front Roller Assembly (Inc. Key No. 37) | 1 |
| 39 | 061000-920 | Front Roller Shaft | 1 |
| 40 | 061306-810 | Knob Nut M6 | 1 |
| 41 | 061805-680 | Coil Spring | 1 |
| 42 | 061801-250 | Coil Spring (B) | 1 |
| 43 | 975655-001 | Dust Bag | 1 |
| 44 | *** | Sanding Belt (Not Shown) | 1 |
| | 972000-491 | Owner's Manual | |

NOTE: "A"– The assembly shown represents an important part of the Double Insulated System. To avoid the possibility of alteration or damage to the system, service should be performed by your nearest Sears Repair Center. Contact your nearest Sears Retail Store for Service Center information.

* Standard Hardware Item — May Be Purchased Locally
 *** Complete Assortment Available At Your Nearest Sears Retail Store

Get it fixed, at your home or ours!

For repair of major brand appliances **in your own home...**
no matter who made it, no matter who sold it!

1-800-4-MY-HOMESM Anytime, day or night
(1-800-469-4663)

www.sears.com

To bring in products such as vacuums, lawn equipment and electronics
for repair, call for the location of your nearest **Sears Parts & Repair Center.**

1-800-488-1222 Anytime, day or night

www.sears.com

For the replacement parts, accessories and owner's manuals
that you need to do-it-yourself, call **Sears PartsDirect**SM!

1-800-366-PART 6 a.m. – 11 p.m. CST,
(1-800-366-7278) 7 days a week

www.sears.com/partsdirect

To purchase or inquire about a Sears Service Agreement:

1-800-827-6655

7 a.m. – 5 p.m. CST, Mon. – Sat.

Para pedir servicio de reparación a domicilio,
y para ordenar piezas con entrega a domicilio:

1-888-SU-HOGARSM
(1-888-784-6427)

Au Canada pour service en français:

1-877-LE-FOYERSM
(1-877-533-6937)

