

IMPORTANT MANUAL

Do Not Throw Away

SEARS
operator's
manual

MODEL NO.
358.797180-26cc
(17" Cutting Path)

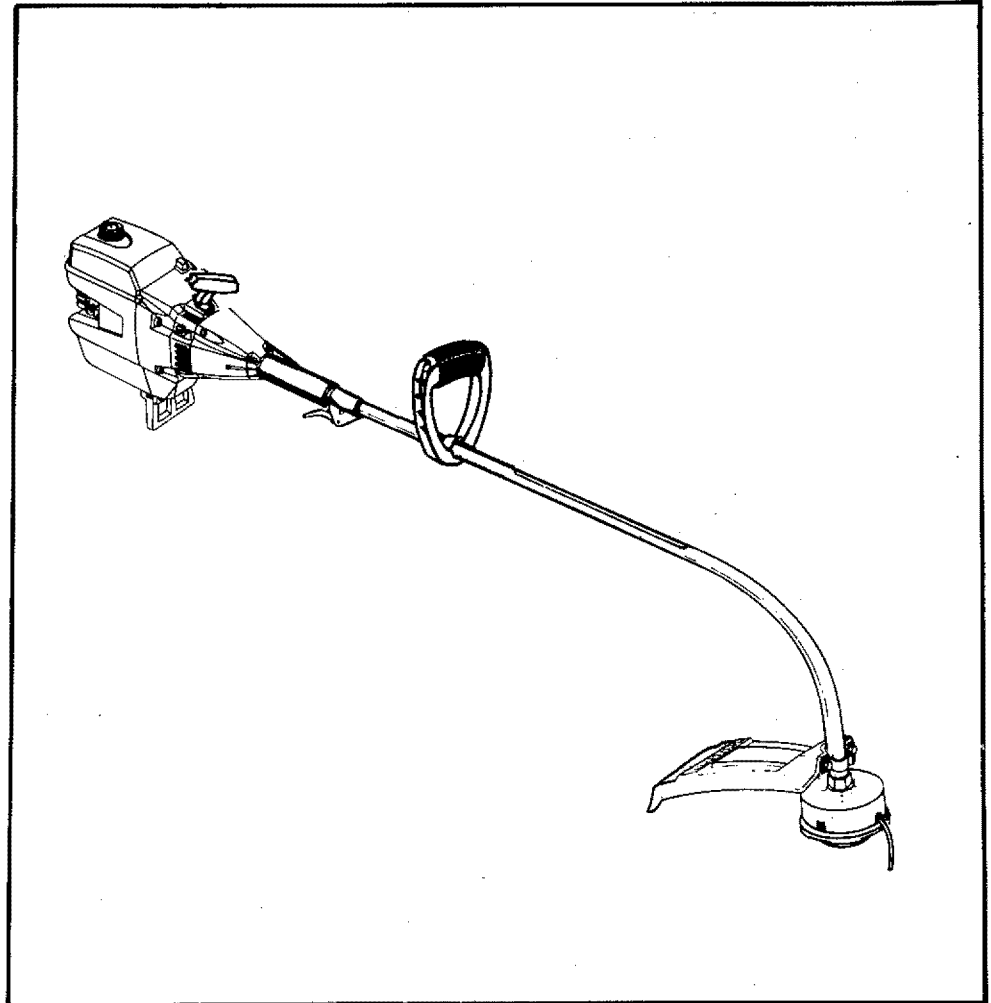

Always Wear Eye Protection During Operation

SEARS / CRAFTSMAN®

26cc GAS WEEDWACKER®

▲ WARNING:

Read the Operator's Manual
and Follow All Warnings
and Safety Instructions.
Failure To Do So Can Result
in Serious Injury.

2 Cycle Engine

Fuel Mix 40:1

- Assembly
- Operation

- Maintenance
- Repair Parts

Sold by Sears, Roebuck and Co., Chicago, Ill. 60684 U.S.A.

ONE YEAR LIMITED WARRANTY ON CRAFTSMAN WEEDWACKER®

For One Year from date of purchase, when this Weedwacker® is maintained, lubricated, and tuned up according to the operating and maintenance instructions in the operator's manual, Sears will repair free of charge any defect in material or workmanship.

This warranty excludes nylon line, spark plug, and air cleaner; which are expendable parts and become worn during normal use.

If this Weedwacker® is used for commercial or rental purposes, this warranty applies for only 30 days from the date of purchase.

WARRANTY SERVICE IS AVAILABLE BY CONTACTING THE NEAREST SEARS SERVICE CENTER/DEPARTMENT IN THE UNITED STATES. This warranty applies only while this product is in use in the United States.

This warranty gives you specific legal rights, and you may also have other rights which vary from state to state.

SEARS, ROEBUCK AND CO. DEPT. D/731 CR-W, SEARS TOWER CHICAGO, IL 60684

TABLE OF CONTENTS

<p>WARNINGS AND SAFETY INSTRUCTIONS 3</p> <p>KNOW YOUR TRIMMER 6</p> <p>ASSEMBLY 7</p> <p>ACCESSORIES 10</p> <p>ENGINE INFORMATION 11</p> <p style="padding-left: 20px;">A. Fueling Your Engine 11</p> <p style="padding-left: 20px;">B. Pre-Operation Checks 12</p> <p style="padding-left: 20px;">C. Starting Instructions 12</p> <p style="padding-left: 20px;">D. Operating Instructions 13</p> <p>USING YOUR TRIMMER 13</p> <p style="padding-left: 20px;">A. Trimmer Safety 14</p> <p style="padding-left: 20px;">B. Trimmer Line Advance 14</p> <p style="padding-left: 20px;">C. Cutting Methods 15</p> <p style="padding-left: 20px;">D. Line Replacement 16</p>	<p>GENERAL MAINTENANCE 17</p> <p style="padding-left: 20px;">A. Maintenance Safety 17</p> <p style="padding-left: 20px;">B. Air Filter 17</p> <p style="padding-left: 20px;">C. Starter Rope 18</p> <p style="padding-left: 20px;">D. Flexible Drive Shaft Lubrication 19</p> <p style="padding-left: 20px;">E. Carburetor Adjustments 20</p> <p style="padding-left: 20px;">F. Storage 22</p> <p style="padding-left: 20px;">G. Trouble Shooting Chart 22</p> <p>REPAIR PARTS LIST 23</p> <p>INDEX 26</p> <p>QUICK REFERENCE PAGE 27</p>
---	---

SPECIFICATIONS

ENGINE TYPE:	2-Cycle, Air-Cooled
DISPLACEMENT:	26cc
ENGINE RPM:	Operating — 7500 Idle — 2800 - 3200
IGNITION:	Solid State
CARBURETOR:	Diaphragm All Positions with adjustable fuel mixture jets
ENGINE "OFF":	Positive Switch
STARTER:	Auto Rewind
MUFFLER:	Temperature Limiting (not spark arresting)
CLUTCH:	Centrifugal
FUEL TANK:	17 fl. oz.
SPARK PLUG:	71-86555 (CJ-14)
SPARK PLUG GAP:	.025"
MODULE AIR GAP:	.010" / .014"
LUBRICATION:	Gasoline/Oil Mixture - 40:1 (See "Fueling Your Engine")
CUTTING LINE:	.080" Diameter Sears Laser Line®
SHAFT LENGTH:	48"

NOTE: LASER LINE® IS A REGISTERED TRADEMARK OF WHITE CONSOLIDATED INDUSTRIES, INC.

MANUFACTURED UNDER ONE OR MORE OF THE FOLLOWING U.S. PATENTS: 3,708,967; 3,826,068; 3,859,776; 4,035,912; 4,052,789; 4,054,992; 4,067,108; 4,104,797; 4,114,269; 4,124,938; 4,156,312; 4,156,967; 4,161,820; 4,167,812; 4,269,372; 4,286,675; DES.249,630; 4,107,901; 4,112,653; 4,136,446; 4,168,572; 4,183,138; 4,189,833; 4,211,004; 4,211,005; 4,236,311; 4,236,312; 4,290,200; 4,362,074; 4,366,622; 4,382,356; 4,451,983; 4,483,069. U.S. AND FOREIGN PATENTS PENDING.

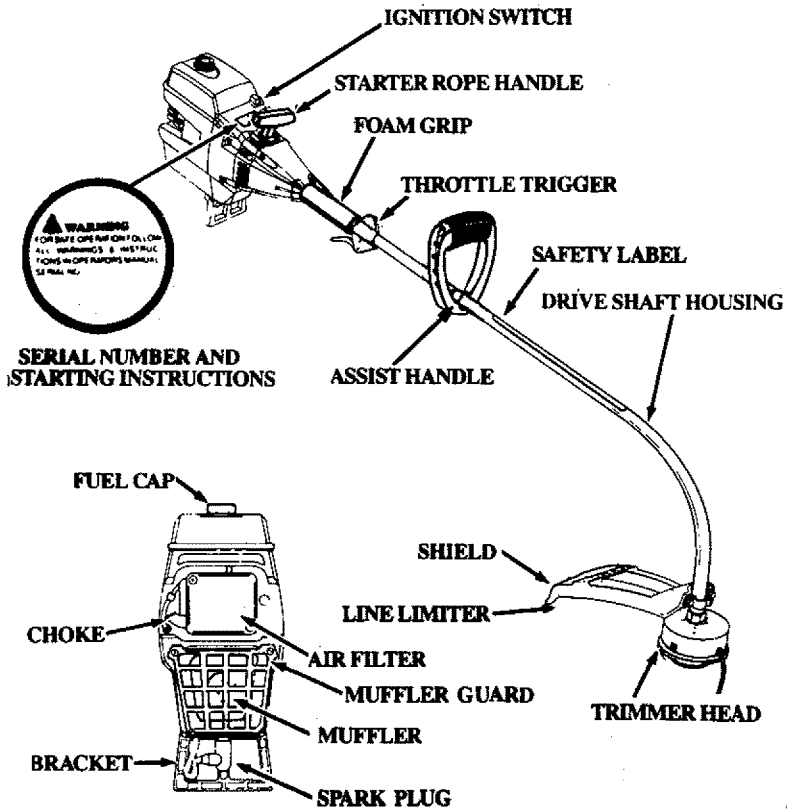

⚠ WARNINGS AND SAFETY INSTRUCTIONS

⚠ WARNING – THIS POWER TOOL CAN BE DANGEROUS!

This tool can cause serious injury or blindness to the operator and others. The warnings and safety instructions in this manual must be followed to provide reasonable safety and efficiency in using this tool. The operator is responsible for following the warnings and instructions in this manual and on the tool. **Read the entire Operator's Manual before assembling and using this tool!** Restrict the use of this power tool to persons who read, understand, and follow the warnings and instructions in this manual and on the tool.



⚠ DANGER

NEVER USE BLADES WITH THIS TOOL.

- THE BLADE CAN COME OFF AND SERIOUSLY INJURE YOU AND OTHERS.
- THIS TOOL IS DESIGNED FOR LINE TRIMMER USE ONLY.

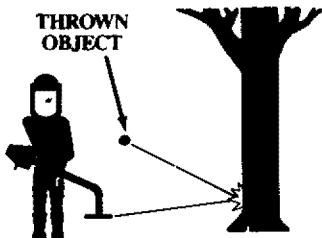

⚠ WARNING

THE TRIMMER LINE CAN THROW OBJECTS VIOLENTLY.

- YOU CAN BE BLINDED OR INJURED.
- WEAR EYE AND LEG PROTECTION.

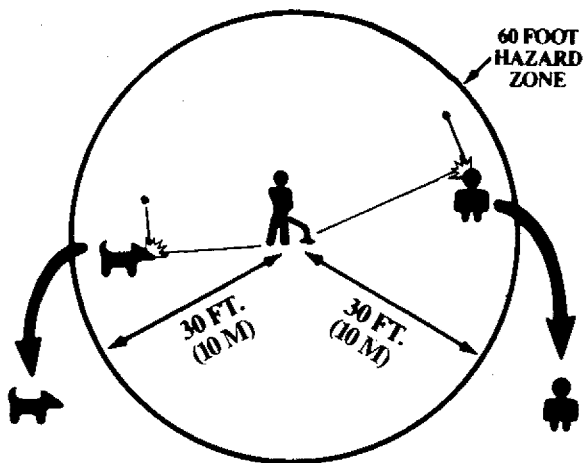

⚠ WARNING

HAZARD ZONE FOR THROWN OBJECTS.

- THE TRIMMER LINE CAN THROW OBJECTS VIOLENTLY.
- OTHERS CAN BE BLINDED OR INJURED.
- KEEP PEOPLE AND ANIMALS 30 FEET (10 METERS) AWAY.



OPERATOR'S
MANUAL



SAFETY
LABEL

⚠ WARNING

READ OPERATOR'S MANUAL.

- FOLLOW ALL WARNINGS AND INSTRUCTIONS.
- FAILURE TO DO SO CAN RESULT IN SERIOUS INJURY.

▲ WARNINGS AND SAFETY INSTRUCTIONS (Continued)

▲ OPERATOR SAFETY

1. Always wear a safety face shield or safety goggles. See "Accessories."
2. Keep hair, fingers, and all other parts of the body away from openings and moving parts. Always wear heavy, long pants, boots, and gloves. Do not wear loose clothing, jewelry, short pants, sandals, or go barefoot. Secure hair so it is above shoulder length. Being fully covered will help protect you from pieces of toxic plants (such as poison ivy) thrown by the Trimmer Head, which could be more of a hazard than touching the plant itself.
3. Do not operate this tool when you are tired, ill, or under the influence of alcohol, drugs, or medication.
4. Always use the assist handle. See "Assembly."
5. Wear hearing protection if you use this tool for more than 1½ hours per day.
6. Never start or run the engine inside a closed room or building. Breathing exhaust fumes can kill.
7. Keep handles free of oil and fuel.

▲ TOOL SAFETY

1. Inspect entire tool before each use. Replace damaged parts. Check for fuel leaks and make sure all fasteners are in place and securely fastened.
2. Replace trimmer head parts that are cracked, chipped, broken, or damaged in any other way before using the tool.
3. Use only .080" diameter Sears Laser Line®. Never use wire, rope, string, etc.
4. Be sure the shield is properly attached.
5. Use only the specified trimmer head. See "Specifications." Make sure the trimmer head is properly installed and fastened. Refer to "Assembly."
6. Be sure the trimmer head stops turning when engine idles. See "Carburetor Adjustments."
7. Make carburetor adjustments with the drive shaft housing supported to prevent the trimmer line from contacting any object. Hold the tool by hand; do not use the optional shoulder strap for support.
8. Keep others away when making carburetor adjustments.
9. Use only accessories or attachments as recommended for this tool by Sears.

▲ FUEL SAFETY

1. Move at least 10 feet (3 meters) away from fueling site before starting engine.
2. Use a container approved for fuel.
3. Do not smoke or allow smoking near fuel or the tool or while using the tool.
4. Wipe up all fuel spills before starting engine.
5. Stop engine before removing fuel cap. Allow the engine to cool before refueling.
6. Before storing the tool, use up fuel left in the fuel lines and carburetor by starting the engine and letting it run until it stops.
7. Store tool and fuel in an area where fuel vapors cannot reach sparks or open flames from water heaters, electric motors or switches, furnaces, etc.

▲ CUTTING SAFETY

1. Inspect the area to be cut before each use. Remove objects (rocks, broken glass, nails, wire, string, etc.) which can be thrown or become entangled in the trimmer head.
2. Keep others including children, animals, bystanders, and helpers outside the 60 foot (20 meter) Hazard Zone. Stop the engine immediately if you are approached.
3. Always keep the engine on the right side of your body.
4. Hold the tool firmly with both hands.
5. Do not overreach or use from unstable surfaces such as ladders, trees, steep slopes, rooftops, etc. Use extra care when cleaning on stairways. Keep firm footing and balance at all times.
6. Keep trimmer head below waist level.
7. Do not raise the engine above your waist. The trimmer head can come dangerously close to your body.
8. Keep all parts of your body away from the trimmer head and muffler when the engine is running.
9. Use only for jobs explained in this manual.

▲ MAINTENANCE SAFETY

1. Maintain the tool according to recommended procedures. Keep the trimmer line at the proper length.
2. Never start the engine with the clutch shroud removed. The clutch can fly apart and cause serious injury.
3. Disconnect the spark plug before performing maintenance except for carburetor adjustments.
4. Make carburetor adjustments with the drive shaft housing supported to prevent the trimmer line from contacting any object. Hold the tool by hand; do not use the optional shoulder strap for support.
5. Keep others away when making carburetor adjustments.
6. Use only genuine replacement parts as recommended by Sears.

▲ TRANSPORTING AND STORAGE

1. Hand carry the tool with the engine stopped and the muffler away from your body.
2. Allow the engine to cool, run fuel out of the fuel system, and secure the tool before transporting in a vehicle or storing.
3. Before storing the tool, use up fuel left in the fuel lines and carburetor by starting the engine and letting it run until it stops.
4. Store tool and fuel in an area where fuel vapors cannot reach sparks or open flames from water heaters, electric motors or switches, furnaces, etc.
5. Store the tool so the line limiter cannot accidentally cause injury. The tool can be hung by the drive shaft housing or by the bracket below the engine.
6. Store tool out of reach of children.

If situations occur which are not covered in this manual, use care and good judgement. Contact your Sears Service Center/Department if you need assistance.

SAFETY NOTICE

Exposure to vibrations through prolonged use of gasoline powered hand tools could cause blood vessel or nerve damage in the fingers, hands, and wrists of people prone to circulation disorders or abnormal swellings. Prolonged use in cold weather has been linked to blood vessel damage in otherwise healthy people. If symptoms occur such as numbness, pain, loss of strength, change in skin color or texture, or loss of feeling in the fingers, hands, or wrists, discontinue the use of this tool and seek medical attention. An anti-vibration system does not guarantee the avoidance of these problems. Users who operate power tools on a continual and regular basis must monitor closely their physical condition and the condition of this tool.

KNOW YOUR TRIMMER

A. INTRODUCTION

Your Trimmer is a versatile product developed for large lawns and to make short work of a variety of lawn care tasks — trimming, scalping, mowing, and sweeping.

Special Features Include:

- Centrifugal Clutch
- All-Position Carburetor
- Adjustable, Cushioned Assist Handle
- Semi Automatic Line Feed Trimmer Head
- 17" Cutting Path

B. UNPACKING INSTRUCTIONS

1. Remove contents from the carton if you have not done so.
2. Check parts against the list below.
3. Examine parts for damage. Do not use damaged parts.
4. *Notify your Sears Store immediately if a part is missing or damaged.*

NOTE: It is normal to hear the fuel filter rattle in an empty fuel tank.

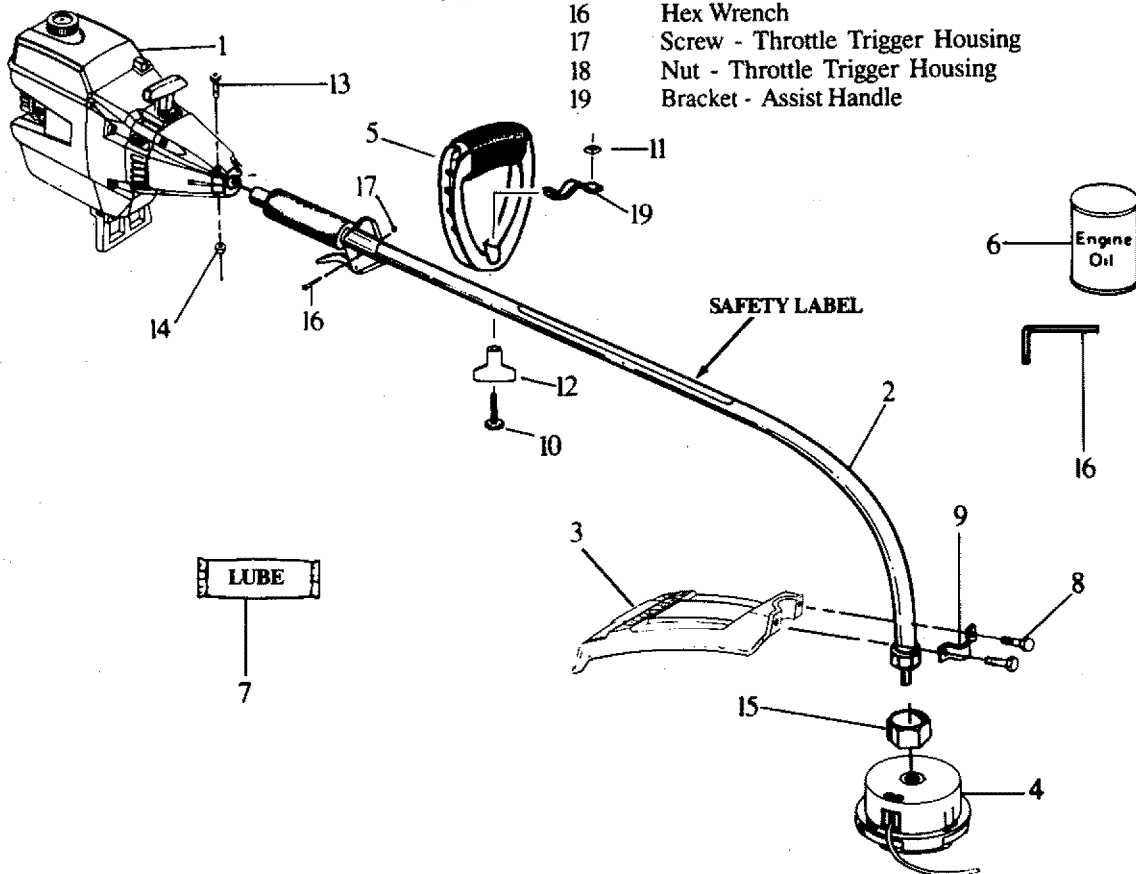

C. CARTON CONTENTS

KEY NO.		QTY.
1	Engine	1
2	Drive Shaft Assembly w/Safety Label	1
3	Shield	1
4	Trimmer Head	1
5	Assist Handle	1
6	2-cycle Engine Oil	1
—	Operator's Manual (Not Shown)	1
—	Loose Parts Bag (Not Shown)	1
* LOOSE PARTS BAG CONTENTS:		
7	Flex Shaft Lube	1
8	Screw - Shield	2
9	Bracket - Shield	1
10	Squared Head Screw - Assist Handle	1
11	Hex Nut - Assist Handle	1
12	T-Handle - Assist Handle	1
13	Hex Screw - Clutch Shroud	2
14	Hex Nut - Clutch Shroud	2
15	Dust Cup - Drive Shaft Housing	1
16	Hex Wrench	1
17	Screw - Throttle Trigger Housing	1
18	Nut - Throttle Trigger Housing	1
19	Bracket - Assist Handle	1

SPECIAL NOTICE

For users on U.S. Forest Land and in some states, including California (Public Resources Codes 4442 and 4443), Idaho, Maine, Minnesota, New Jersey, Oregon, and Washington: Certain internal combustion engines operated on forest, brush, and/or grass-covered land in the above areas are required to be equipped with a spark arrester, maintained in effective working order, or the engine must be constructed, equipped, and maintained for the prevention of fire. Check with your state or local authorities for regulations pertaining to these requirements. Failure to follow these requirements is a violation of the law. **This unit is not factory-equipped with a spark arrester;** however, a spark arrester is available as an optional part. If a spark arrester is required in your area, contact your Sears Service Center or Parts Department for Spark Arrester kit #952-701612.

ASSEMBLY (If tool is received assembled, repeat all steps in this section to be sure assembly is correct and is adjusted for the operator.)

A. PREPARATION

This Operator's Manual has been developed to help you assemble the tool and to provide its safe operation. It is important that you read the entire manual to become familiar with the tool *before* you begin assembly.

1. READ YOUR OPERATOR'S MANUAL

2. Tools you will need:

- Flathead Screwdriver.
- 1-1/4 inch wrench or adjustable wrench.
- Hex Wrench provided with tool.

B. ASSEMBLY STEPS

1. DRIVESHAFT HOUSING – Figure 1

- Place the two Screws (from the loose parts bag) into the holes on the Clutch Shroud as shown in Figure 1.
- Position the Lock-Nuts (from the loose parts bag) in the hex openings in the Clutch Shroud.
- Tighten the Screws with the small hex wrench provided just enough to hold the hardware together while holding the Lock-Nuts with your other hand.
- Remove the packing cover from the straight end of the Drive Shaft Housing.

NOTE: Make sure the Flexible Drive Shaft does not fall out of the Drive Shaft Housing when the packing cover is removed. Dirt on the Shaft will significantly reduce the life of the tool. If the Flexible Drive Shaft falls out of the Housing, clean, relube, then reinstall. See "Flexible Drive Shaft Lubrication" in the Maintenance section.

- Align the bottom groove on the Drive Shaft Housing with the Ridge on the inner, lower wall of the Clutch Shroud opening. Turn the Arbor Shaft as necessary to align the square end of the Flexible Drive Shaft with the square inside the Clutch Shroud opening. Firmly push the Drive Shaft Housing into the Clutch Shroud until it contacts the Foam Grip or is within 1/8 inch. Figure 1.

- Tighten the Screws alternately with the small hex wrench until secure.

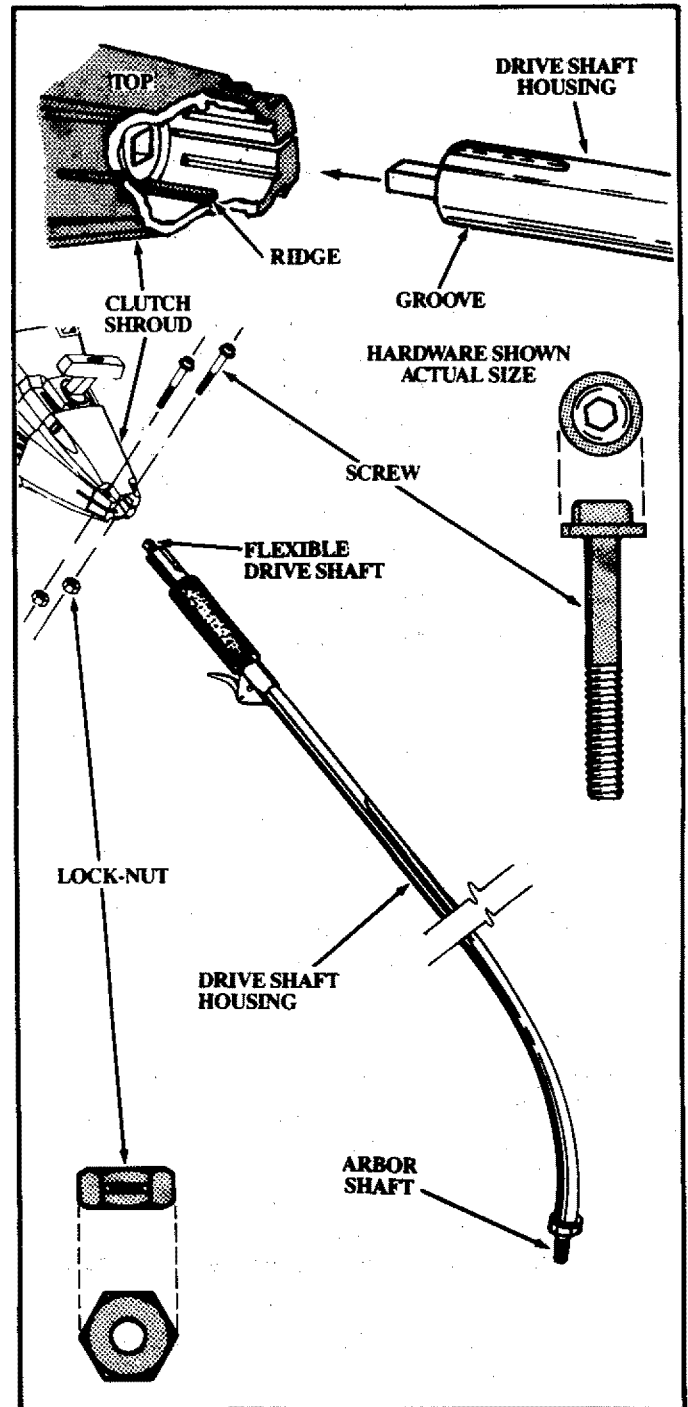

Figure 1

2. THROTTLE CABLE – Figures 2, 3, 4 & 5

CAUTION: Do not bend the throttle cable.

- Slide the Throttle Trigger Housing from the Foam Grip about 1" to 1-1/2".
- Insert the Throttle Cable through the tunnel in the Foam Grip until the end of the Cable extends at least 2 inches beyond the Grip. Figure 3.
- Hold the Trigger away from the Drive Shaft Housing and insert the barrel end of the Throttle Cable into the round opening in the Trigger as shown in Figure 3.

NOTE: When inserting the barrel end of the Throttle Cable into the round opening in the Trigger, make sure that the barrel is completely inserted and the Throttle Cable is located in the split in the Arm. Figure 4 (inset).

- Push the Trigger back into the Housing while guiding the Cable through the split in the arm. (Figure 4.) Guide the arm into the Foam Grip tunnel while replacing the Throttle Trigger Housing flush against the Grip.
- Squeeze Trigger against the Foam Grip. Install Screw and Nut. Figure 5. See Caution below.

CAUTION: Do not overtighten the screw. Make sure the trigger will move freely. There must be at least 1/8" free play in the trigger. Figure 5. Make sure the trigger will move freely so the engine can fully return to idle when the trigger is released. The trimmer head must not turn at idle speed to avoid serious injury to the operator and others.

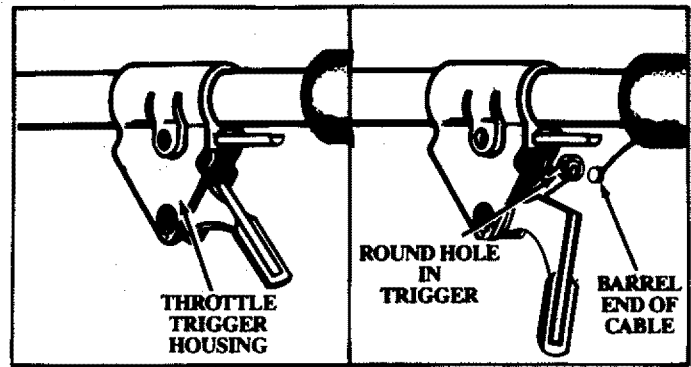

Figure 2

Figure 3

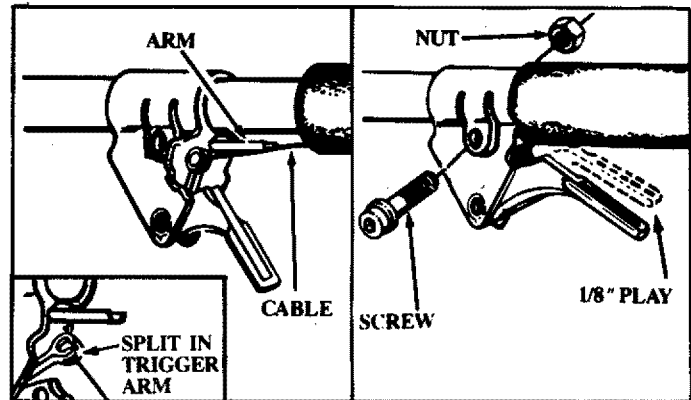

Figure 4

Figure 5

3. TRIMMER HEAD – Figures 6 & 7

- Place the Dust Cup on the Drive Shaft Housing over the hex nut that is assembled on the Arbor Shaft. Figure 6 (inset).
- Hold the Dust Cup with a wrench to keep the Arbor Shaft from turning. Figure 6.
- Thread the Trimmer Head onto the Arbor Shaft, against the Dust Cup, and as tight as possible with your hand. Figure 6.

NOTE: Unless the Trimmer Head is tightened adequately, it can unthread the first time the engine is started. If this occurs, reinstall the Trimmer Head and tighten more securely.

- Press the Tap Button and pull a minimum of 4 inches of Line from the Trimmer Head. Figure 7. Approximately 2 inches of line can be advanced each time the Tap Button is pressed.

NOTE: To remove Trimmer Head, hold the Dust Cup with a wrench and unthread the Trimmer Head.

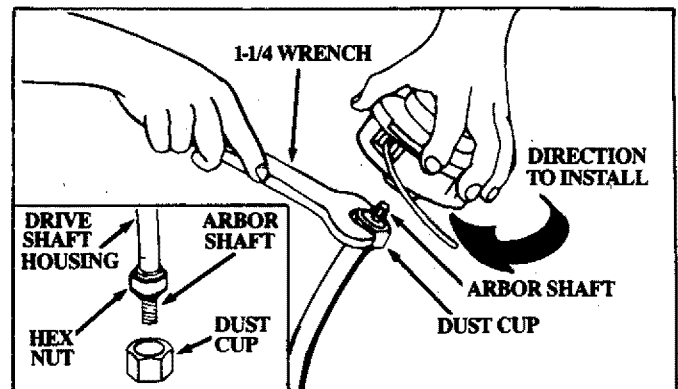

Figure 6

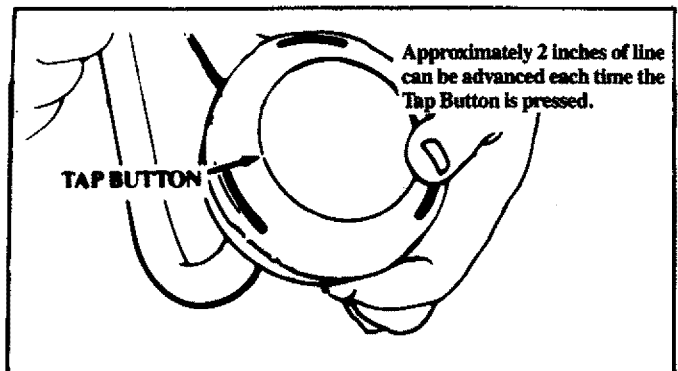

Figure 7

4. Shield – Figure 8

⚠ WARNING

Failure to install the shield in the position shown in Figures 8 and 9 can result in serious injury to the operator. The length of the shield must be aligned with the length of the drive shaft housing. Direct the widest part of the shield toward the engine.

CAUTION: The Line Limiter (on the underside of the shield) is sharp and can cut you.

- Match the Key (Raised area) on the Shield with the Keyway ("V" slot) on the Drive Shaft Housing. Figure 8 (inset).
- Rest the bottom of the Shield on top of the shoulder of the Drive Shaft Housing above the Dust Cup.

NOTE: The bottom of the Shield must rest on top of the shoulder of the Drive Shaft Housing.

- Install the Shield retaining Bracket and Screws as shown in Figure 8.

NOTE: It is easier to start the Screws with a screwdriver and finish tightening with a 3/8" wrench.

- Tighten the Screws evenly and securely.

NOTE: A small space may be left between the Bracket and the Shield when hardware is fully tightened.

5. ASSIST HANDLE – Figures 9 & 10

- Insert the end of the Drive Shaft Housing through the Assist Handle. Figure 9 (inset).
- Align the Assist Handle between the Safety Label and the Throttle Trigger Housing. Seat the Drive Shaft Housing in the groove in the Assist Handle. Figure 9.
- Insert the tab on the Assist Handle Bracket into the slot on the Assist Handle. Figure 9. Then, lay the Assist Handle Bracket over the Drive Shaft Housing.
- Drop the threaded end of the square-head T-Handle Screw through the opening in the top of the T-Handle. Figure 10.
- Pull on the threaded end of the Screw to bring the square head of the Screw past the pin inside the T-Handle. Figure 10.
- Insert the Screw up through the hole in the Assist Handle and then through the Assist Handle Bracket. Figure 9.
- Thread screw into square nut. Tighten securely.

CAUTION: When adjusting the Assist Handle for comfort, be sure that the Assist Handle remains between Engine and Safety Label on Drive Shaft Housing. Figure 9.

- Adjust Assist Handle up or down the Shaft Housing for comfort.

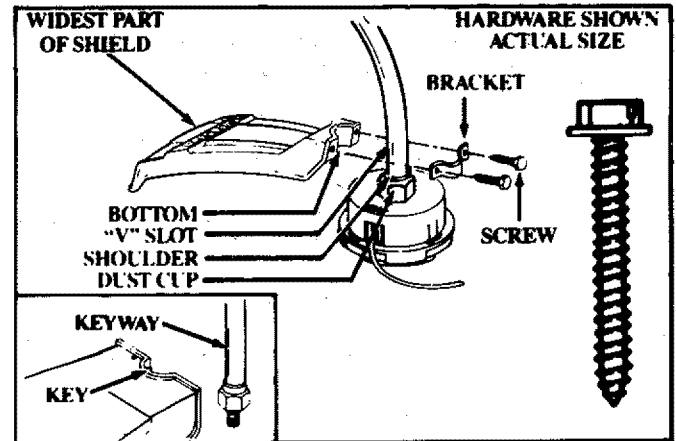

Figure 8

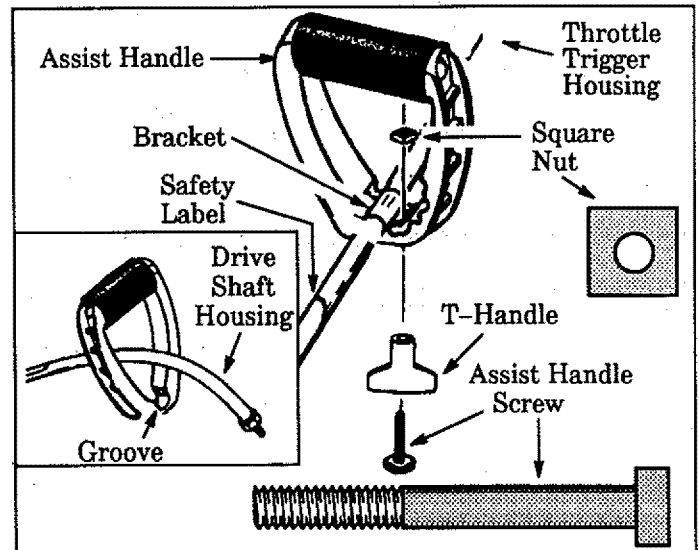

Figure 9

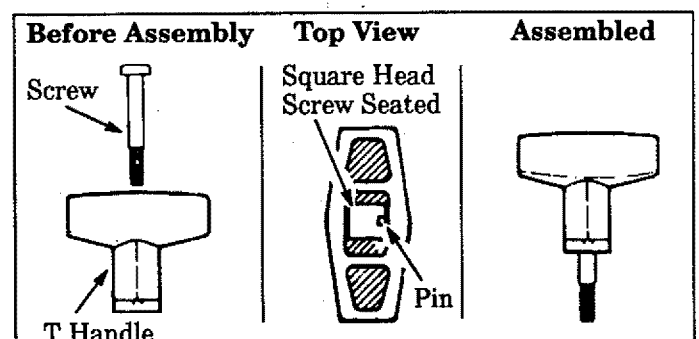

Figure 10

6. OPERATING POSITION – Figure 11

a. Before starting the Engine, stand as shown in Figure 11 and check for the following:

- 1). Left arm fully extended, hand holding Assist Handle.
- 2). Right arm slightly bent, hand holding the Foam Grip, fingers on Throttle Trigger.
- 3). Engine below waist level.
- 4). Weight of tool evenly distributed between arms.
- 5). Without operator bending over, the Trimmer Head is near and parallel to the ground and easily contacts the material to be cut.

b. Adjust the Assist Handle up or down the Drive Shaft Housing (*but above the Safety Label*) to a comfortable position.

- 1). Loosen the T-Handle by hand, adjust Assist Handle. Retighten T-Handle by hand *only*.
- 2). Rotate the Assist Handle from left to right if it is necessary to tilt the angle of the Trimmer Head such as when cutting a large, sloped area such as a ditch bank.

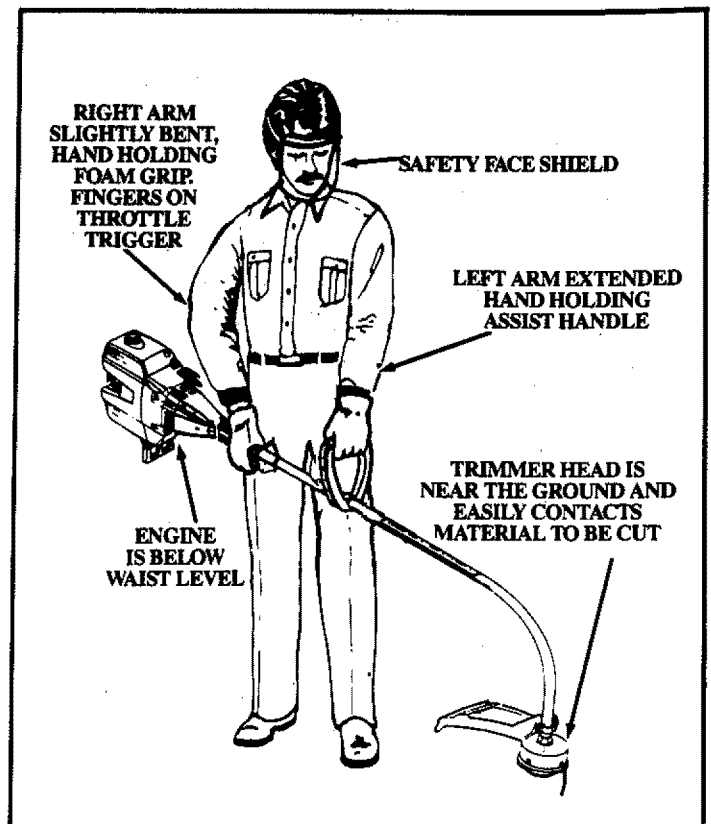

Figure 11

ACCESSORIES

The following accessories are available through Sears Retail Stores, Catalog, Outlets or Service Centers.

ITEM	STOCK NO.
Safety Face Shield	9-18613
Safety Goggles	9-1859
2-Cycle Engine Oil	71-30143
Spark Plug	71-86555
Fuel Cap	71-79705
Replacement Trimmer Head (available only through Sears Service Centers)	71-85805
Replacement Nylon Trimmer Line	
— 400 ft.	71-85778
— 200 ft.	71-85608
Replacement Spool with Line	71-85810
Flex Shaft Lube	530-030102
Shoulder Strap Kit	71-85783
Spark Arrestor Kit	952-701612
Operator's Manual	530-067910

ENGINE INFORMATION

A. FUELING YOUR ENGINE

1. FUEL SAFETY

- Use only recommended fuel mixtures.
- Mix and pour fuel outdoors and where there are no sparks or flames.
- Use a container approved for fuel.
- Do not smoke or allow smoking near fuel or the tool or while using the tool.
- Wipe up all fuel spills before starting the engine.
- Move at least 10 feet (3 meters) away from fueling site before starting engine.
- Stop engine before removing fuel cap. Allow the engine to cool before refueling.
- Empty fuel tank before storing tool. Use up fuel left in carburetor by starting engine and letting engine run until it stops.
- Store tool and fuel in an area where fuel vapors cannot reach sparks or open flames from water heaters, electric motors or switches, furnaces, etc.

2. FUEL MIXTURE

- Your tool is powered by a 2-cycle engine which requires a fuel mixture of regular unleaded gasoline and a high quality engine oil specially made for 2-cycle, air cooled engines.

The internal design of the 2-cycle engine requires lubrication of moving parts. Lubrication is provided when the recommended mixture of gasoline and oil is used.

- Genuine Sears 40:1, 2-cycle engine oil is strongly recommended for the protection of your unit. Extensive engineering tests have proven that Sears 2-cycle engine oil resists break-down at operating temperatures common to 2-cycle engines, resulting in dependable performance and longer engine life.
- Gasoline must be clean and not over two months old. After a short period of time, gasoline will chemically break down and form compounds that cause hard starting and damage in 2-cycle engines.
- The correct measure of gasoline to oil is very important. Too much oil in the mixture will foul the spark plug.

CAUTION: Too little oil or incorrect oil will cause the engine to overheat and seize.

- Always mix the fuel thoroughly in a container since gasoline and oil do not readily combine. *Do not mix gasoline and oil directly in the fuel tank.*

3. USE THE FOLLOWING ONLY:

- 3.2 oz. 2-cycle engine oil to 1 gal. gasoline or 8 oz. 2-cycle engine oil to 2.5 gal. gasoline.
(40 parts gasoline to 1 part oil)

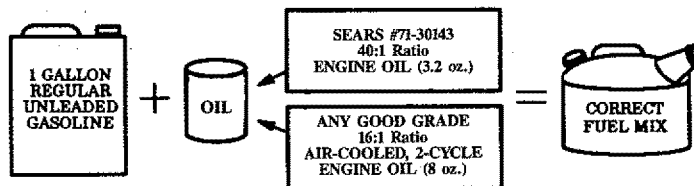

SEARS 2-cycle engine oil mixed at 40:1 is strongly recommended.

If SEARS 2-cycle engine oil is not available, use a good quality, 2-cycle engine oil mixed at a ratio of 16:1 (8 oz. oil to 1 gallon gasoline).

4. DO NOT USE:

- NMMA Oil — National Marine Manufacturers Association (formerly BIA)
 - Does not have proper additives for 2-cycle, air-cooled engines and can cause engine damage.
- AUTOMOTIVE OIL —
 - Does not have proper additives for 2-cycle, air-cooled engines and can cause engine damage.

CAUTION

Experience indicates that alcohol blended fuels (called gasohol or using ethanol or methanol) can attract moisture which leads to separation and formation of acids during storage. Acidic gas can damage the fuel system of an engine while in storage. To avoid engine problems, do not leave fuel in the unit when storing for 30 days or longer. Start the engine and let it run until the fuel lines and carburetor are empty. Use fresh fuel next season. See the "Storage" section for additional information. Never use engine or carburetor cleaner products in the fuel tank or permanent damage can occur.

5. HOW TO MIX FUEL AND FILL TANK

- Pour 1/2 of the regular unleaded gasoline to be used into an approved, marked container. *Do not mix gasoline and oil directly in the fuel tank.*
- Add entire measure of engine oil.
- Cover container tightly and shake for one minute.
- Slowly remove fuel container cover.
- Add remainder of gasoline.
- Cover container tightly and shake again.
- Slowly remove fuel container cover.
- Slowly remove fuel cap. See "Specifications" for location.
- Fill the tank using a spout or funnel.
- Reinstall the fuel cap securely.

B. PRE-OPERATION CHECKS

⚠ WARNING

Review all Warnings and Safety Instructions in this manual.

Before operating your tool, always:

1. Inspect the entire tool before each use. Replace damaged parts. Check for fuel leaks and make sure all fasteners are in place and securely fastened.
2. Replace trimmer head parts that are cracked, chipped, broken, or damaged in any other way before using this tool.
3. Use only .080" diameter Sears Laser Line®. Never use wire, rope, string, etc.
4. Use only with the shield properly attached.

5. Use only the specified trimmer head. See "Specifications." Make sure the trimmer head is properly installed and securely fastened. Refer to "Assembly."
6. Be sure trimmer head stops turning when engine idles. See "Carburetor Adjustments."
7. Make carburetor adjustments with the drive shaft housing supported to prevent the trimmer line from contacting any object. Hold the tool by hand. Do not use the optional shoulder strap for support.
8. Keep others away when making carburetor adjustments.
9. Use only accessories or attachments as recommended by Sears for this tool.
10. Clean the air filter if dirty *before* operating the tool. Refer to "Specifications," for air filter location.

C. STARTING INSTRUCTIONS (For location of controls, refer to "Specifications.")

1. Before starting the engine.

- a. Fuel engine. Move at least 10 feet (3 meters) away from fueling site.
- b. Extend 4-6 inches of Line from Trimmer Head.

⚠ WARNING

The trimmer head will turn as soon as the engine starts.

- c. Rest Engine and Shield on ground, supporting Trimmer Head off the ground away from trees, bushes, onlookers, etc. Figure 12.
- d. If using optional Shoulder Strap, place Shoulder Strap on your shoulder. *Start engine before clipping Shoulder Strap to the tool.*

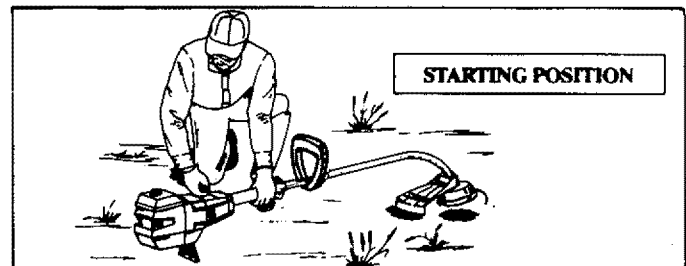

Figure 12

2. For a Cold Engine:

- a. Move Ignition Switch to "on." Figure 13.
- b. Move Choke to "full" position. Figure 14.
- c. Grasp Foam Grip and squeeze Throttle Trigger fully. *Keep Throttle Trigger fully squeezed until engine runs smoothly (through step "g").*
- d. Pull Starter Rope sharply until engine attempts to run, but no more than 8 pulls at full choke to avoid flooding the engine. *The engine "attempts to run" may be hard to hear. The operator must listen carefully.* After 8 pulls, proceed to step "e." even if engine has not attempted to run.
- e. Move Choke to "half" position. Figure 14.
- f. Pull Starter Rope sharply until engine attempts to run, but no more than 5 pulls.

NOTE: If engine has not started after 5 pulls, repeat steps "a" through "f."

- g. Allow engine to run 5 seconds, then move Choke to "off" position. Figure 9. *Keep Throttle Trigger fully squeezed until engine runs smoothly.*

NOTE: If engine dies with Choke at "off" position, repeat steps "e" through "g."

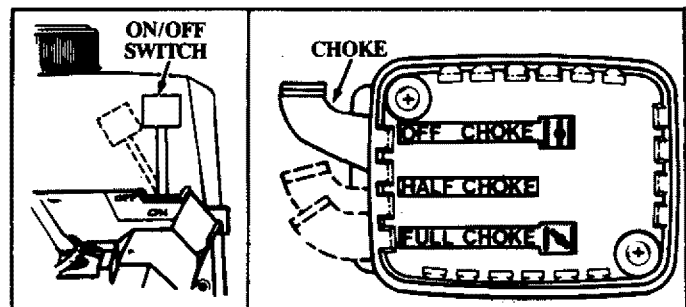

Figure 13

Figure 14

⚠ WARNING

Avoid any bodily contact with the muffler when starting a warm engine. A hot muffler can cause serious burns.

3. For a Warm Engine:

- a. Move Ignition Switch to "on." Figure 13.
 - b. Move Choke to "half" position. Figure 14.
 - c. Grasp Foam Grip and squeeze Throttle Trigger fully. *Keep Throttle Trigger fully squeezed until engine runs smoothly.*
 - d. Pull Starter Rope sharply until engine runs, but no more than 5 pulls.
 - e. Move Choke to "off" position. Figure 14. *Keep Trigger fully squeezed until engine runs smoothly.*
- NOTE:** If engine does not run after 5 pulls, it is probably flooded. Wait a few minutes and repeat procedure with Choke at "off" position. Figure 14.

4. For a Warm Engine (After Running Out of Fuel):

- a. Refuel engine. Move 10 feet (3 meters) away from the fueling site.
- b. Move Ignition Switch to "on." Figure 13.
- c. Move Choke to "full" position. Figure 14.
- d. Grasp Foam Grip and squeeze Throttle Trigger fully. *Keep Throttle Trigger fully squeezed until engine runs smoothly.*
- e. Pull Starter Rope sharply until engine attempts to run, but no more than 5 pulls.

- f. Move Choke to "off" position. Figure 14.
- g. Pull Starter Rope until engine runs, but no more than 5 pulls. *Keep Trigger fully squeezed until engine runs smoothly.*

NOTE: If engine has not started, pull Starter Rope 5 more pulls. If engine still does not run, it is probably flooded. Wait a few minutes and repeat procedure with Choke at "off" position. Figure 14.

D. OPERATING INSTRUCTIONS

1. Bring the engine to cutting speed before entering the material to be cut.
 - a. Do not run the engine at a higher speed than necessary. The cutting line will cut efficiently when the engine is run at less than full throttle. At lower speeds, there is less engine noise and vibration. The trimmer line will last longer and will be less likely to "weld" onto the spool.
 - b. If the Trimmer Head does not turn when the engine is accelerated, make sure the Drive Shaft Housing is properly seated in the Engine Shroud. Refer to "Assembly-Drive Shaft Housing."
2. Always release the Throttle Trigger and allow the engine to return to idle speed when not cutting.
3. Make sure the Trimmer Head stops turning when the Throttle Trigger is released and the engine runs at idle speed. For correction, refer to "Carburetor Adjustments."
4. To stop the engine:
 - a. Release the Throttle Trigger.
 - b. Move Ignition Switch to the "OFF" position. Figure 13.

USING YOUR TRIMMER

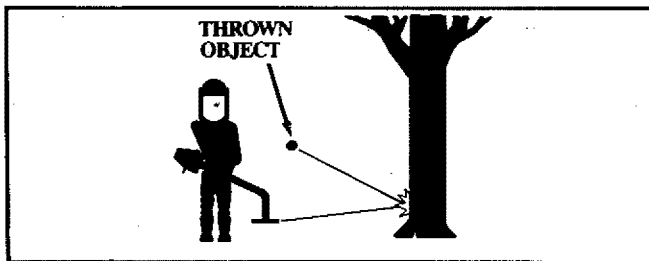

⚠ WARNING — THROWS OBJECTS

The rapidly moving line causes objects to be thrown violently. The shield will not provide complete protection to the operator or others. The operator must wear a safety face shield or goggles. Always wear heavy, long pants and boots. Keep others at least 30 feet (10 meters) away.

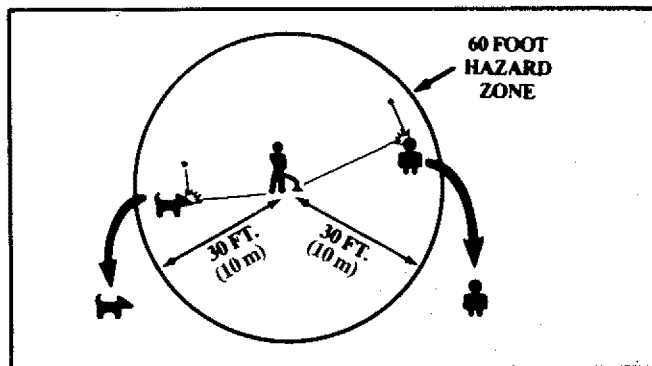

⚠ WARNING — HAZARD ZONE

This tool will throw objects and cut. Keep others including children, animals, bystanders, and helpers at least 30 feet (10 meters) away from the operator and tool. Stop the engine if you are approached.

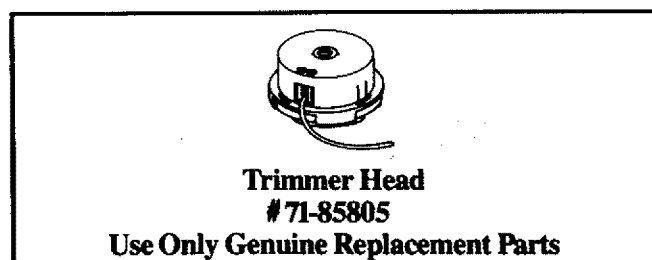

⚠ WARNING — DAMAGED TRIMMER HEAD

Trimmer head parts that are chipped, cracked, broken, or damaged in any other way can fly apart and cause serious injury. Do not use. Throw damaged parts away. Replace damaged parts before using the tool.

A. TRIMMER SAFETY

1. OPERATOR

- Always wear a safety face shield or goggles. See "Accessories."
- Keep hair, fingers, and all other parts of the body away from openings and moving parts. Always wear heavy, long pants, boots, and gloves. Do not wear loose clothing, jewelry, short pants, sandals, or go barefoot. Secure hair so it is above shoulder length. Being fully covered will help protect you from pieces of toxic plants (such as poison ivy) thrown by the Trimmer Head, which could be more of a hazard than touching the plant itself.
- Do not operate this tool when you are tired, ill, or under the influence of alcohol, drugs, or medication.
- Do not swing the tool with such force that you are in danger of losing your balance.
- Never start or run the engine inside a closed room or building.
- Keep handles free of oil and fuel.

2. TOOL

- Inspect the entire tool before each use. Replace damaged parts. Check for fuel leaks and make sure all fasteners are in place and securely fastened.
- Use only .080" diameter Sears Laser Line®. Never use wire, rope, string, etc.
- Be sure the shield is properly attached.
- Make sure the trimmer head is properly installed and securely fastened. Refer to "Assembly."
- Be sure the trimmer head stops turning when the engine idles. See "Carburetor Adjustments."

- Make carburetor adjustments with the drive shaft housing supported to prevent the trimmer line from contacting any object. Hold the tool with your hand. Do not use the optional shoulder strap for support.
- Keep others away when making carburetor adjustments.
- Use only accessories or attachments recommended for this tool by Sears.

3. CUTTING

- Inspect the area to be cut before each use. Remove objects (rocks, broken glass, nails, wire, string, etc.) which can be thrown or become entangled in the trimmer head.
- Always keep the engine on the right side of your body.
- Hold the tool firmly with both hands.
- Keep firm footing and balance. Do not over-reach.
- Keep the trimmer head below waist level.
- Do not raise the engine above your waist.
- Keep all parts of your body away from the trimmer line and muffler when the engine is running.
- Use only for jobs explained in this manual.

B. AUTOMATIC LINE ADVANCE

- The trimmer line advances automatically as the line wears and reduces the cutting path.
- The line will wear faster and will advance more frequently when cutting against hard surfaces such as rocks, bricks, concrete, metal fences, etc., than when cutting against woody objects such as trees or wooden fences.
- If line does not advance properly:
 - Operate the engine at full throttle and allow the line to strike a hard surface such as concrete or the ground.
 - If line is 4" or less, stop the engine and check for line binding or tangling on the spool. See "Trimmer Head" in the Maintenance Section for rewinding instructions.
- Always keep the shield in place when the tool is being operated. Figure 22.

⚠ WARNING

Use only .080" diameter Sears Laser Line®. Other sizes of line will not advance properly and can cause serious injury. Do not use other materials such as wire, string, rope, etc. Wire can break off during cutting and become a dangerous missile.

⚠ WARNING

Use minimum speed and do not crowd the line when cutting around hard objects (rocks, gravel, loose objects, etc), which can damage to the trimmer head, become entangled in the line, or be thrown causing a serious hazard.

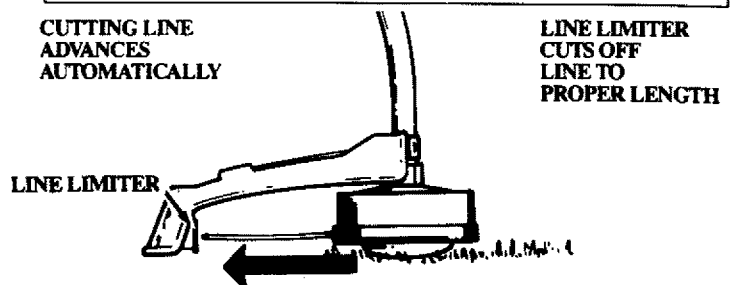

Figure 22

C. CUTTING METHODS

- The tip of the line does the cutting. Allow the line to trim at its own pace. You will achieve better results by not crowding the line into the cutting area. The right and wrong ways are shown in Figure 16.
- The line will easily remove grass and weeds from around walls, fences, trees, and flower beds, *but it also can cut the tender bark of trees or shrubs and scar fences.* To help avoid damage to vegetation or trees with tender bark, shorten line to 4-5 inches and use less than full throttle.
- The line will wear faster and will advance more frequently when you are cutting against rocks, bricks, concrete, metal fences, etc., than when cutting against trees or wooden fences.
- For trimming or scalping, use less than full throttle to increase line life and decrease head wear.
 - during light duty cutting.
 - next to rocks, bricks, concrete, metal fences, etc..
- For mowing or sweeping, use full throttle for a good clean job.
- Avoid letting the trimmer head continuously contact the ground during normal cutting. Constant contact will cause trimmer head damage and premature wear.

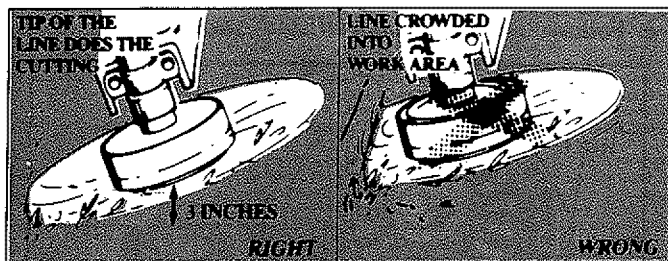

Figure 16

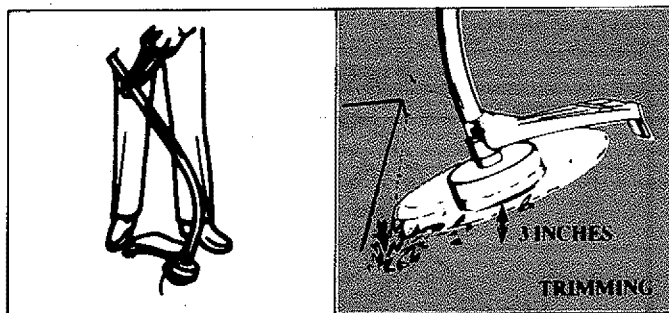

Figure 17

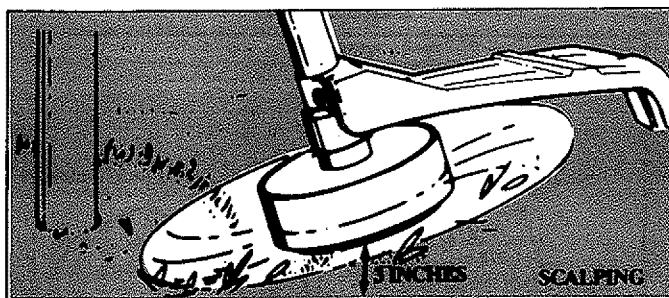

Figure 18

⚠ WARNING
Always wear eye protection. Never lean over the trimmer head. Rocks or debris can ricochet or be thrown into eyes and face and cause blindness or other serious injury.

1. TRIMMING — Figure 17

Hold the tap button about 3 inches above the ground and tilt the trimmer head at an angle. Allow the tip of the line to do the cutting. Do not force the trimmer line into the work area.

2. SCALPING — Figure 18

The scalping technique removes unwanted vegetation. Hold the tap button about 3 inches above the ground and tilt the trimmer head at an angle. Allow the tip of the line to strike the ground around trees, posts, monuments, etc. *This technique increases line wear.*

3. MOWING — Figure 19

Your trimmer is ideal for mowing in places conventional lawn mowers cannot reach. In the mowing position, keep the line parallel to the ground. Avoid pressing the head into the ground as this can scalp the ground and damage the tool.

4. SWEEPING — Figure 20

The fanning action of the rotating line can be used for a quick and easy clean up. Keep the line parallel to and above the surfaces being swept and move the tool from side to side.

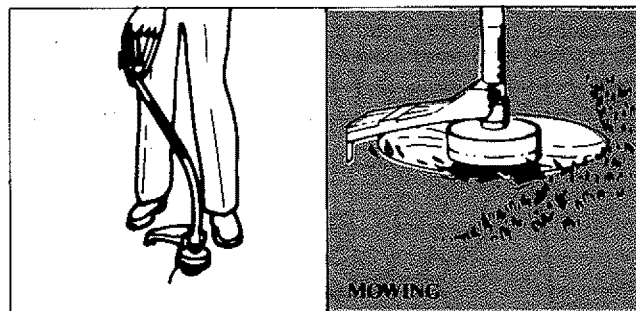

Figure 19

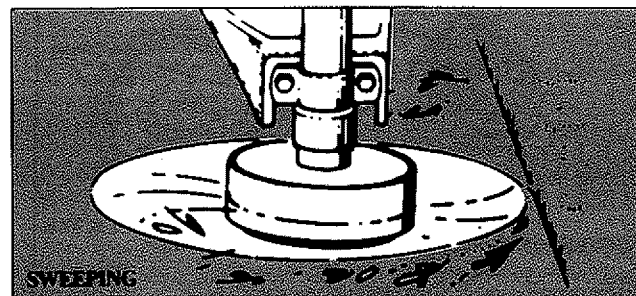

Figure 20

D. LINE REPLACEMENT

● For proper line feed:

- Use only genuine Sears pre-wound spools and .080" diameter Sears Laser Line®. Use of other types of spools or lines can result in excessive breakage, line welding, and improper line feed.
- Pre-wound spools offer the most convenient method for replacing line as well as optimum performance.

● Always clean dirt and debris from the spool and hub when performing any type maintenance.

1. Installing Spool w/Line

- a. Hold the Trimmer Head as shown in Figure 21. Press the Lock Tab and turn Cover counterclockwise.
- b. Remove the Cover and Spool. Figure 22.
- c. Clean dirt and debris from all parts.
- d. Inspect all Trimmer head parts for damage. Replace damaged parts.

▲ WARNING

Trimmer head parts that are chipped, cracked or damaged in any way can fly apart and cause serious injury. Do not use. Replace damaged parts before using the tool.

- e. Insert about 6 inches of Line from the inside of the Hub through the Line Exit Hole to the outside to keep the Line from backing into the Head. Figure 23.
- f. Route the Line behind the Balancing Pin (Figure 23) while carefully placing the Spool in the Hub.
- g. Pull on the Line extending outside the Hub to make sure the Line will not advance. See Inset, Figure 23. This indicates that the Line is routed properly.
- h. Reinstall Cover:
 - 1.) Align the four Catches on the Hub with the cutouts in the Cover. Figure 24.
 - 2.) Press the Cover onto the Hub.
 - 3.) Turn Cover clockwise. Figure 21.

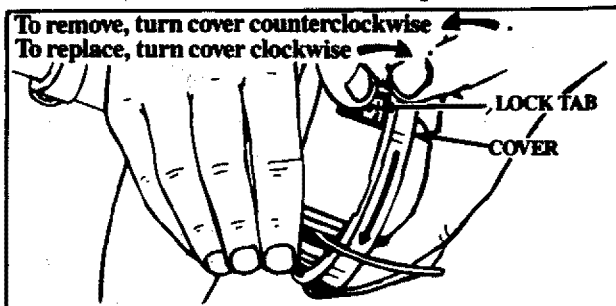

Figure 21

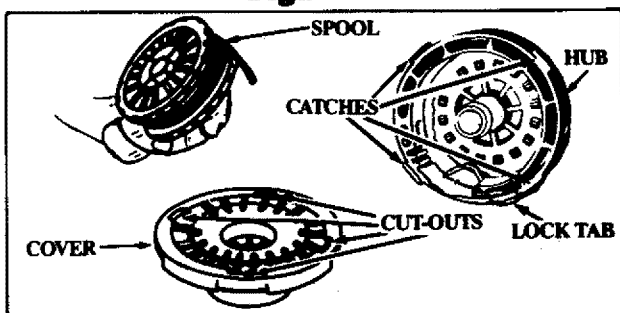

Figure 22

- i. Check to make sure all four Catches and the Lock Tab are properly fastened as shown in Figure 24, then test the Cover by trying to turn it counterclockwise.
- j. Pull on the Line again from outside the Hub. If the Line can be pulled from the assembled head, it is not properly routed around the Balancing Pin and will feed continuously when the Trimmer Head turns. Remove Cover and re-route Line as shown in Figure 23.

▲ WARNING

All four catches must be fastened and the lock tab latched onto the cover. If installed improperly, the cover can fly off and become a dangerous missile.

2. Installing Line on Spool

- a. Follow "Installing Spool w/Line," steps "a-d" and remove any Line remaining on the Spool.
- b. Use a 40 foot length of .080" Sears Laser Line®.
- c. Insert 1/16" to 1/8" of the end of the Line through one of the holes in the rim of the Spool. Allow no more than 1/8" line extend beyond the rim to avoid interference with line release action. Figure 25.
- d. Wind the Line onto the Spool in the direction as shown by the arrow on the Spool and as tightly and evenly as possible so the line will feed properly. Figure 25.

CAUTION: The trimmer head will not function properly if the spool is filled beyond the notches around the outside edge of the spool.

- e. Follow "Installing Spool w/Line" steps "e-j."

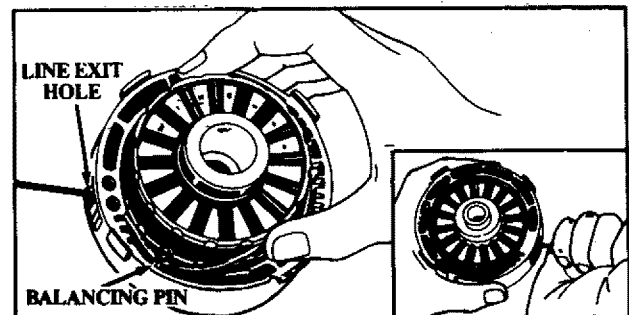

Figure 23

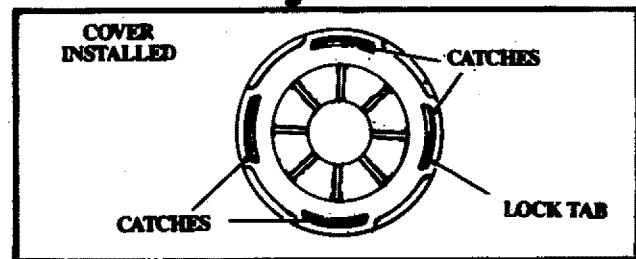

Figure 24

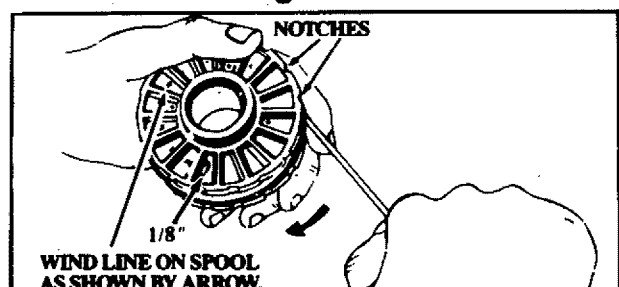

Figure 25

3. Trouble Shooting the Trimmer Line

- Does not advance, or breaks while cutting
 - Improperly routed in head.
 - Improperly wound onto spool.
 - Line size incorrect.
 - Too little line outside head.
- Welds on spool
 - Line size incorrect.
 - Incorrect spool.
 - Crowding line against material being cut.
 - Cutting at higher speeds than necessary.
 - Wound loosely on spool.

- Releases continuously
 - Wound beyond notches on spool.
 - Improperly routed in head.
 - Line size incorrect.
 - Shield installed improperly.
- Usage is excessive
 - Improperly routed in head.
 - Line size incorrect.
 - Cutting at high speeds around hard objects.
 - Crowding line against material being cut.
- Pulls back into head
 - Too little line outside of head.

GENERAL MAINTENANCE

A. MAINTENANCE SAFETY

1. Maintain the tool according to recommended procedures. Keep the trimmer line at the proper length.
2. Never start the engine with the clutch shroud removed. The clutch can fly apart and cause serious injury.
3. Disconnect the spark plug before performing maintenance except for carburetor adjustments.
4. Make carburetor adjustments with the drive shaft housing supported to prevent the trimmer line from contacting any object. Hold the tool with your hand. Do not use the optional shoulder strap for support.
5. Keep others away when making carburetor adjustments.
6. Be sure the trimmer head stops turning when engine idles. See "Carburetor Adjustments."
7. Use only .080" diameter Sears Laser Line[®]. Never use wire, rope, string, etc.
8. Replace trimmer head parts that are cracked, chipped, broken, or damaged in any other way before using the tool.
9. Use only genuine replacement parts as recommended by Sears.
10. Inspect entire tool. Replace damaged parts. Check for fuel leaks. Make sure all fasteners are in place and securely fastened.

B. AIR FILTER

A dirty air filter decreases the life and performance of the engine and increases fuel consumption.

Clean the Air Filter:

- Always after 5 tanks of fuel or 5 hours of operation, whichever is less.
 - More frequently, in dusty conditions.
1. Loosen the two screws on the Air Filter Cover enough to remove the cover from the engine. Figure 26.
 2. Remove the Air Filter from the Cover. Figure 27.

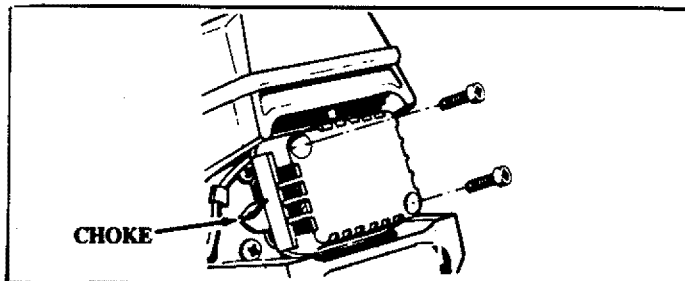

Figure 26

3. Wash Filter in soap and water.
4. Squeeze Filter dry and replace in Cover.

CAUTION: Do not clean the air filter in gasoline or other flammable solvent to avoid creating a fire hazard.

5. Reinstall the Air Filter Cover, making sure the Choke exit slot (Figure 27) is placed over the Choke Lever.

CAUTION: Fit air filter into the corners of the housing to keep dust from entering the engine and causing engine damage.

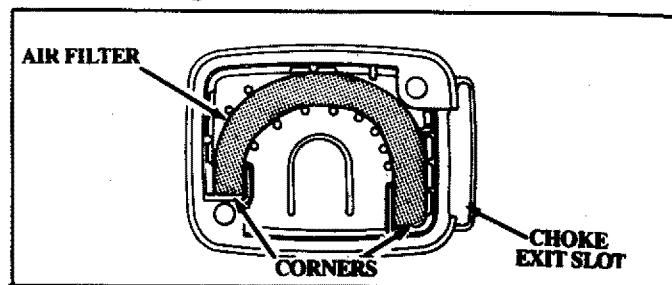

Figure 27

C. STARTER ROPE

⚠ DANGER

Never start the engine with the clutch shroud removed. The clutch will fly apart and cause serious injury.

⚠ WARNING

Do not remove the retaining tab and screw to remove pulley. The spring beneath the pulley is under tension and can fly out causing serious injury. If any part of the pulley housing assembly is damaged other than the rope, do not use the tool. Take it to your Sears Service Center.

1. Disconnect Spark Plug Wire. Figure 28.
2. Remove the Screw and Nut in the Throttle Trigger Housing as shown in Figure 2. Hold the Throttle Trigger away from Drive Shaft Housing and remove Throttle Cable from Trigger. Pull Cable out of Foam Grip tunnel.
3. Remove the four Clutch Shroud Screws as shown in Figure 28 with the small hex wrench provided.
4. Separate the Clutch Shroud from the Engine. Figure 29.

⚠ DANGER

Use only a hand tool to remove the clutch. Do not use any type of motorized tool or strike the clutch in any way. Otherwise, the clutch will fly apart and cause serious injury.

5. Hold the "Flats" of the Clutch with an adjustable wrench as shown in Figures 29 and 30 and remove the Nut counterclockwise with a 3/8" socket wrench.

NOTE: Clutch will slide off the crankshaft intact. *Do not disassemble clutch.*

6. Remove the Beveled Washer, Clutch and Large Flat Washer as shown in Figure 30.
7. Remove the Pulley Housing from the Engine. Figure 30.
8. Remove Rope Retention Screw. Remove any remaining rope.
9. Hold Pulley Housing as shown in Figure 31. Hand turn the Pulley clockwise as far as it will go. Then, turn the Pulley counterclockwise until the Pulley Notch is aligned with the Housing Notch next to the Retaining Tab and Screw. Figure 31. Next, turn the Pulley one complete turn counterclockwise until the notches are aligned again.
10. Insert the small hex wrench into the hole formed by the Notches to hold the Pulley in position. Figure 31.
11. Use a 42" length of replacement Rope.
12. Move away 10 feet (3 meters) from the fuel tank with the replacement Rope. Use a match and melt both ends of the Rope to prevent fraying.

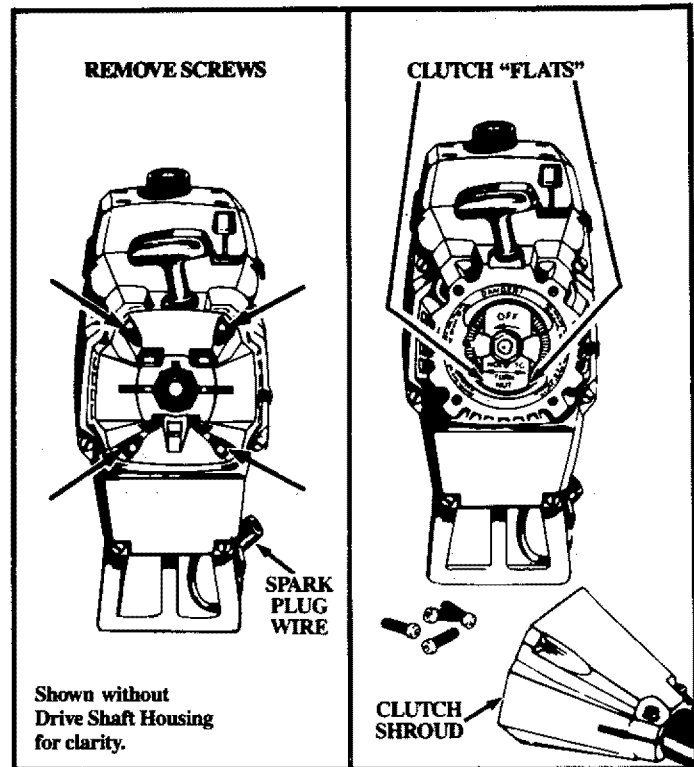

Figure 28

Figure 29

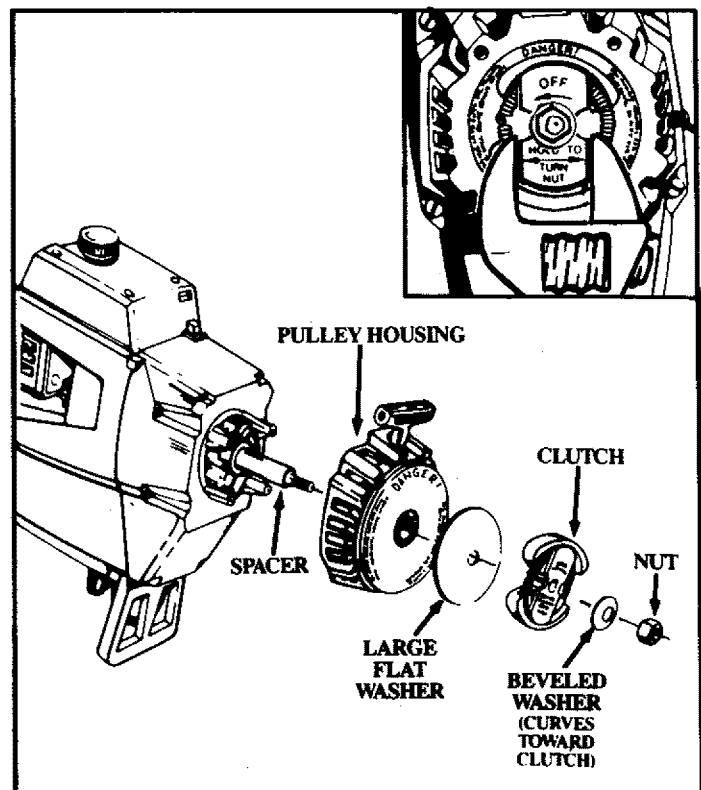

Figure 30

13. Pull the melted ends through a thick, clean rag while the Rope is still hot to obtain smooth, pointed ends.
14. Insert one end of the Rope through the Handle and secure with a knot.
15. Insert the other end of the Rope through the Rope Exit Hole, into the inside of the Housing, into the Pulley, and up through the Pulley Hole. See Inset, Figure 31.
16. Wrap Rope counterclockwise around the Pulley Ratchet and tuck loose end under Rope where it comes out of the Pulley Hole. Leave a 1-inch tail laying flat on top of the Pulley between the Retainer Rib and the rope Retention Screw/Post. Figure 31.
17. Reinstall the Rope Retention Screw into the retention post. Tighten until snug.
NOTE: Do not overtighten the Screw. Overtightening the screw can cause the threads in the screw post to strip out.
18. Hold Rope taut at Rope Exit Hole so it will not move and remove hex wrench.
19. Slowly feed rope into the Pulley Housing.
20. Make sure Spacer is in place as shown in Figure 30, then reverse steps to re-assemble.

CAUTION: When reinstalling the clutch, tighten the nut just until the beveled washer is flattened against the clutch. Over or under tightening the nut can cause engine damage.

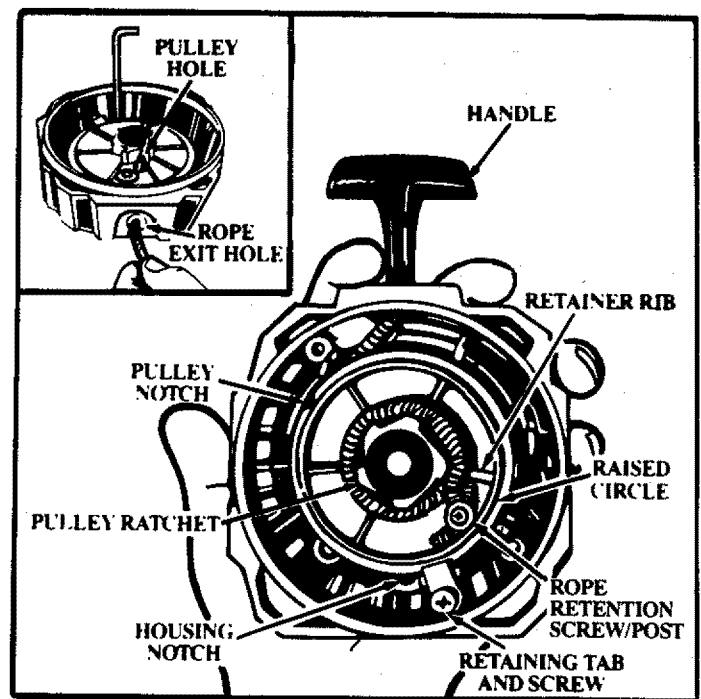

Figure 31

D. FLEXIBLE DRIVE SHAFT LUBRICATION

- Lubricate the Flexible Drive Shaft:
 - After each ten (10) hours of operation.
 - Before operating if the unit has been stored for 90 days or longer.
- Use Flex Shaft Lube Part No. 530-030102.

NOTE: A tube of "Flex Shaft Lube" has been supplied with your unit to be used after the first 10 hours of operation.

- Use the following procedure for best results:

WARNING

If engine has just been operated, avoid touching the muffler. A hot muffler can cause serious burns.

CAUTION: Lay the Flexible Drive Shaft on a clean surface. Avoid laying the shaft on the floor, ground, or on any surface that may have dirt or debris. Even after wiping the shaft, grease residue can pick up dirt particles that can cause damage or premature failure.

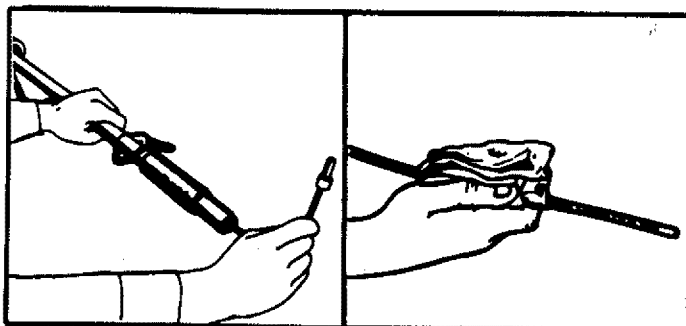

Figure 32

Figure 33

CAUTION: Take care to avoid injuring your hands and fingers with broken wires when checking for damage or wiping the flexible drive shaft. A cloth will not prevent the broken wires from puncturing or tearing your skin.

1. Remove the Screw and Nut in the Throttle Trigger Housing as shown in Figure 2.
2. Hold the Trigger away from the Drive Shaft Housing and remove the barrel end of the Cable from the Trigger as shown in Figure 3.

CAUTION: Do not bend the cable.

3. Pull the Cable from the tunnel in the Foam Grip.
4. Loosen (but do not remove) the Hex Screws and remove the Drive Shaft Housing from the Clutch Shroud. Figure 1.
5. Remove the Flexible Drive Shaft from the Drive Shaft Housing as shown in Figure 32.
6. Check the Flexible Drive Shaft for broken wires, twists or kinks and replace if damage is found.
7. Using a clean cloth, wipe the surface of the Flexible Drive Shaft thoroughly to remove any old grease. Figure 34.
8. Apply a uniform coat of lube to the entire surface of the Flexible Drive Shaft.
9. Inject the remaining contents of the tube into the top of the Drive Shaft Housing.
10. Replace Flexible Drive Shaft in the Drive Shaft Housing.
11. Follow the instructions in "Assembly" to reinstall the Throttle Cable and the Drive Shaft Housing.

E. CARBURETOR ADJUSTMENTS

- This is a complicated task and it is important to follow instructions in sequence as indicated.

⚠ WARNING

Make carburetor adjustments with the drive shaft housing supported to prevent trimmer line from contacting any object. Hold the tool with your hand. Do not use the optional shoulder strap for support.

⚠ WARNING

Keep others away when making carburetor adjustments.

⚠ WARNING

Serious injury to the operator and others can occur if the carburetor is not properly adjusted.

- Poor engine performance can be a result of other causes such as dirty air filter, carbon build-up on muffler outlets, etc. See "Trouble Shooting Chart" before proceeding with carburetor adjustments.
- The carburetor has been carefully adjusted at the factory. However, the operator must be sure that adjustments are made when any of the conditions occur as mentioned in "Trouble Shooting Suggestions" below.
- Very small adjustments can affect engine performance. It is important to turn the screw a very small amount per adjustment and test performance before making further adjustments. Each adjustment should be no more than the width of the slot in the adjusting screws.

1. TROUBLE SHOOTING SUGGESTIONS

- Engine will not continue to run at idle position. See "b. Idle Speed Adjustment" and "e. Low Speed Mixture Adjustment."
- Trimmer Head continues to spin when the engine idles. See "b. Idle Speed Adjustment" and "d. Deceleration Check."
- Engine dies or hesitates when it should accelerate. See "c. Acceleration Check."
- Loss of cutting power which cannot be corrected by cleaning the air filter. See "f. High Speed Mixture Adjustment."
- Engine does not return to idle from full throttle within 2 seconds. See "d. Deceleration Check."
- Engine will not run. See "Trouble Shooting Chart." Then, if the carburetor requires adjustment, begin with "2. Basic Carburetor Settings."

⚠ WARNING

The trimmer line will be spinning during most of this procedure. Wear your protective equipment and observe all safety instructions.

2. BASIC CARBURETOR SETTINGS

NOTE: In most cases, your engine can be made to run properly with minor carburetor adjustments. Refer to "Trouble Shooting Suggestions" in the left column for the condition you are experiencing and follow the instructions. The basic carburetor settings are provided in the event they are required.

- a. Turn the Low Speed Mixture Screw and the High Speed Mixture Screw (Figure 34) clockwise just until they stop. *Do not turn the screws until they are tight as damage to the needle seats can occur.*
- b. Turn the Low Speed Mixture and High Speed Mixture Screws one full turn counterclockwise.
- c. Follow instructions "a. Preparation," through "f. High Speed Mixture Adjustment."

3. PROCEDURE

a. PREPARATION

- 1.) Use a fresh fuel mix. See "Fueling Your Engine."
- 2.) Make sure the line extends to the length allowed by the line limiter to provide correct load on engine.
- 3.) Start the engine. Cut grass for 3 minutes to warm engine. *The engine must be at operating temperature before carburetor adjustments can be performed correctly.*
- 4.) Stop engine and remove air filter by pulling it out with your fingers. Refer to "Specifications" for location.

b. IDLE SPEED ADJUSTMENT

- 1.) Allow engine to idle.
- 2.) Adjust Idle Speed Screw (Figure 34) until the engine continues to run without stalling and without the trimmer head moving.
 - Turn screw clockwise to increase engine speed if the engine stalls or dies.
 - Turn screw counterclockwise to slow engine down and/or to keep trimmer head from turning.
- 3.) Follow instructions in "c. Acceleration Check" and "d. Deceleration Check."
- 4.) No further adjustments are necessary if the trimmer head does not turn at idle speed and if performance is satisfactory.

⚠ WARNING

Recheck idle speed after each adjustment. The trimmer head must not turn at idle speed to avoid serious injury to the operator and others.

c. ACCELERATION CHECK

- 1.) Allow engine to idle.
- 2.) Squeeze Trigger fully
 - a. If performance is satisfactory, proceed to "d. Deceleration Check."
 - b. If the engine does not accelerate smoothly, turn the Low Speed Mixture Screw (Figure 26) counterclockwise a small amount (no more than the width of the slot in the adjusting screw).
- 3.) Repeat step "2.)" until smooth acceleration is obtained.

NOTE: It may be necessary to repeat "b. Idle Speed Adjustment" through "c. Acceleration Check," to obtain correct adjustments.

- 4.) Follow instructions in "d. Deceleration Check."

d. DECELERATION CHECK

- 1.) Allow engine to idle, then squeeze Throttle Trigger fully.
- 2.) Allow engine to run at full speed for about 1 second.
- 3.) Release the Throttle Trigger to the idle position and listen to the deceleration of the engine. It must return to idle smoothly and within 1 to 2 seconds.
 - a. If performance is satisfactory, proceed to step "4.)"
 - b. If the engine slowly or erratically returns to idle or idles erratically, repeat "b. Idle Speed Adjustment" or continue through Low Speed Mixture and High Speed Mixture Adjustments to obtain proper deceleration.
- 4.) Recheck idle speed.

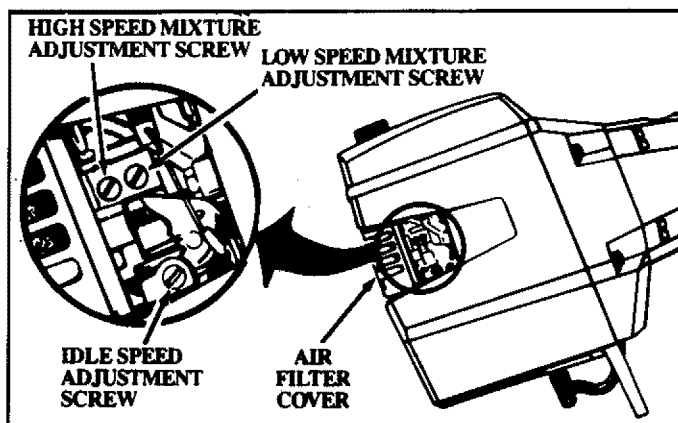

Figure 34

e. LOW SPEED MIXTURE ADJUSTMENT

- 1.) Allow engine to idle.
- 2.) Turn the Low Speed Mixture Screw (Figure 34) slowly clockwise until the speed starts to drop. Note this position.
- 3.) Turn the Low Speed Mixture Screw counterclockwise until the speed increases and then starts to drop again. Note this position.
- 4.) Set the Low Speed Mixture Screw at the midpoint between the two positions.
- 5.) Follow instructions in "c. Acceleration Check" and "d. Deceleration Check."

f. HIGH SPEED MIXTURE ADJUSTMENT

CAUTION: Do not operate engine at full throttle for prolonged periods while making high speed adjustments as damage to the engine can occur.

- 1.) Support the drive shaft housing so the trimmer line is off the ground and will not make contact with any object.
- 2.) Allow engine to idle, then squeeze Throttle Trigger fully.

NOTE: Perform steps "3.)" through "5.)" at full throttle.
- 3.) Turn High Speed Mixture Screw (Figure 34) very slowly clockwise until engine speed is reduced.
- 4.) Turn High Speed Mixture Screw very slowly counterclockwise. Stop when the engine begins to run roughly.
- 5.) Turn the screw slowly the minimum amount clockwise until the engine runs smoothly.
- 6.) Follow instructions in "c. Acceleration Check" and "d. Deceleration Check."

CAUTION: If the engine does not operate according to these instructions after repeating the adjusting steps, do not use the tool. Take it to your Sears Service Center.

g. REINSTALL AIR FILTER

Be sure filter is clean. See "Air Filter" in the Maintenance Section for instructions.

CAUTION: Fit air filter into the corners of the housing to keep dirt from entering the engine and causing engine damage.

F. STORAGE

1. Allow the engine to cool, empty the fuel system, and secure the tool before transporting or storing.
2. Before storing the tool, use up fuel left in the fuel lines and carburetor by starting the engine and letting it run until it stops.

NOTE: If you do not want to remove the fuel from your unit, SEARS CRAFTSMAN Fuel Stabilizer (#71-33500) may be added to fuel left in the tank to minimize gum deposits and acids. If the tank is almost empty, mix stabilizer with fresh fuel in a separate container and add to the tank.

ALWAYS FOLLOW INSTRUCTIONS ON THE STABILIZER CONTAINER. THEN, RUN THE ENGINE AT LEAST 10 MINUTES AFTER STABILIZER IS ADDED TO ALLOW MIXTURE TO REACH CARBURETOR. STORE UNIT IN A SAFE PLACE. SEE STEP 2 (this section).

3. Store tool and fuel in an area where fuel vapors cannot reach sparks or open flames from water heaters, electric motors or switches, furnaces, etc.
4. Store the tool so the line limiter cannot accidentally cause injury. The tool can be hung by the drive shaft housing.
5. Store tool out of reach of children.

WARNING

It is important to prevent gum deposits from forming in essential fuel system parts such as the carburetor, fuel filter, fuel hose, or fuel tank during storage. Experience indicates that alcohol blended fuels (called Gasohol or using ethanol or methanol) can attract moisture which leads to separation and formation of acids during storage. Acidic gas can damage the fuel system of an engine while in storage.

G. TROUBLE SHOOTING CHART

SYMPTOM	CAUSE	REMEDY
Engine will not start or will run only for a few seconds after starting	<ol style="list-style-type: none"> 1. Fuel tank empty. 2. Engine flooded. 3. Spark plug not firing. 4. Fuel not reaching carburetor. 5. Carburetor requires adjustment. 6. None of the above. 	<ol style="list-style-type: none"> 1. Fill tank with correct fuel mixture. 2. See "Starting Instructions." 3. Install new plug. 4. Clean fuel filter; inspect fuel line. 5. See "Carburetor Adjustments." 6. Contact your Sears Service Center.
Engine will not idle properly	<ol style="list-style-type: none"> 1. Idle speed set too fast or too slow. 2. Low speed mixture requires adjustment. 3. Throttle trigger screw too tight. 4. None of the above. 	<ol style="list-style-type: none"> 1. See "Carburetor Adjustments." 2. See "Carburetor Adjustments." 3. Loosen screw to free trigger. 4. Contact your Sears Service Center.
Engine will not accelerate, lacks power, or dies under a load	<ol style="list-style-type: none"> 1. Air filter dirty. 2. Spark plug fouled. 3. Carburetor requires adjustment. 4. Muffler outlets plugged. 5. None of the above. 	<ol style="list-style-type: none"> 1. Clean or replace air filter. 2. Clean or replace spark plug and regap. 3. See "Carburetor Adjustments." 4. Contact your Sears Service Center. 5. Contact your Sears Service Center.
Engine smokes excessively	<ol style="list-style-type: none"> 1. Air filter dirty. 2. Fuel mixture incorrect. 3. High speed mixture requires adjustment. 	<ol style="list-style-type: none"> 1. Clean or replace air filter. 2. Refuel with correct fuel mixture. 3. See "Carburetor Adjustments."
Engine runs hot	<ol style="list-style-type: none"> 1. Fuel mixture incorrect. 2. High speed mixture set too low (lean). 3. Spark plug incorrect. 4. None of the above. 	<ol style="list-style-type: none"> 1. See "Fueling Your Unit." 2. See "Carburetor Adjustments." 3. Replace with correct plug. 4. Contact your Sears Service Center.
Trimmer head turns at idle speed	<ol style="list-style-type: none"> 1. Carburetor requires adjustment. 2. Throttle trigger screw too tight. 3. Clutch requires repair. 	<ol style="list-style-type: none"> 1. See "Carburetor Adjustments." 2. Loosen screw to free trigger. 3. Contact your Sears Service Center.
Trimmer head stops under a load or does not turn when engine is accelerated	<ol style="list-style-type: none"> 1. Drive shaft broken or not engaged. 2. Carburetor requires adjustments. 3. Clutch requires repair. 	<ol style="list-style-type: none"> 1. Replace or see "Assembly." 2. See "Carburetor Adjustments." 3. Contact your Sears Service Center.
Line does not advance or breaks while cutting	<ol style="list-style-type: none"> 1. Line caught between spool and hub. 2. Line improperly wound onto spool. 3. Improper line size. 	<ol style="list-style-type: none"> 1. Remove cover. Check line routing. 2. Rewind spool firmly and evenly. 3. Replace spool.
Excessive line usage	<ol style="list-style-type: none"> 1. Improper line size. 2. Cutting at high speed around hard objects. 3. Crowding line against material being cut. 	<ol style="list-style-type: none"> 1. Use only .080" Sears Laser Line®. 2. Reduce cutting speed around hard objects. 3. Cut with tip of line.

SEARS WEEDWACKER® REPAIR PARTS LIST - 358.797180-26.0cc

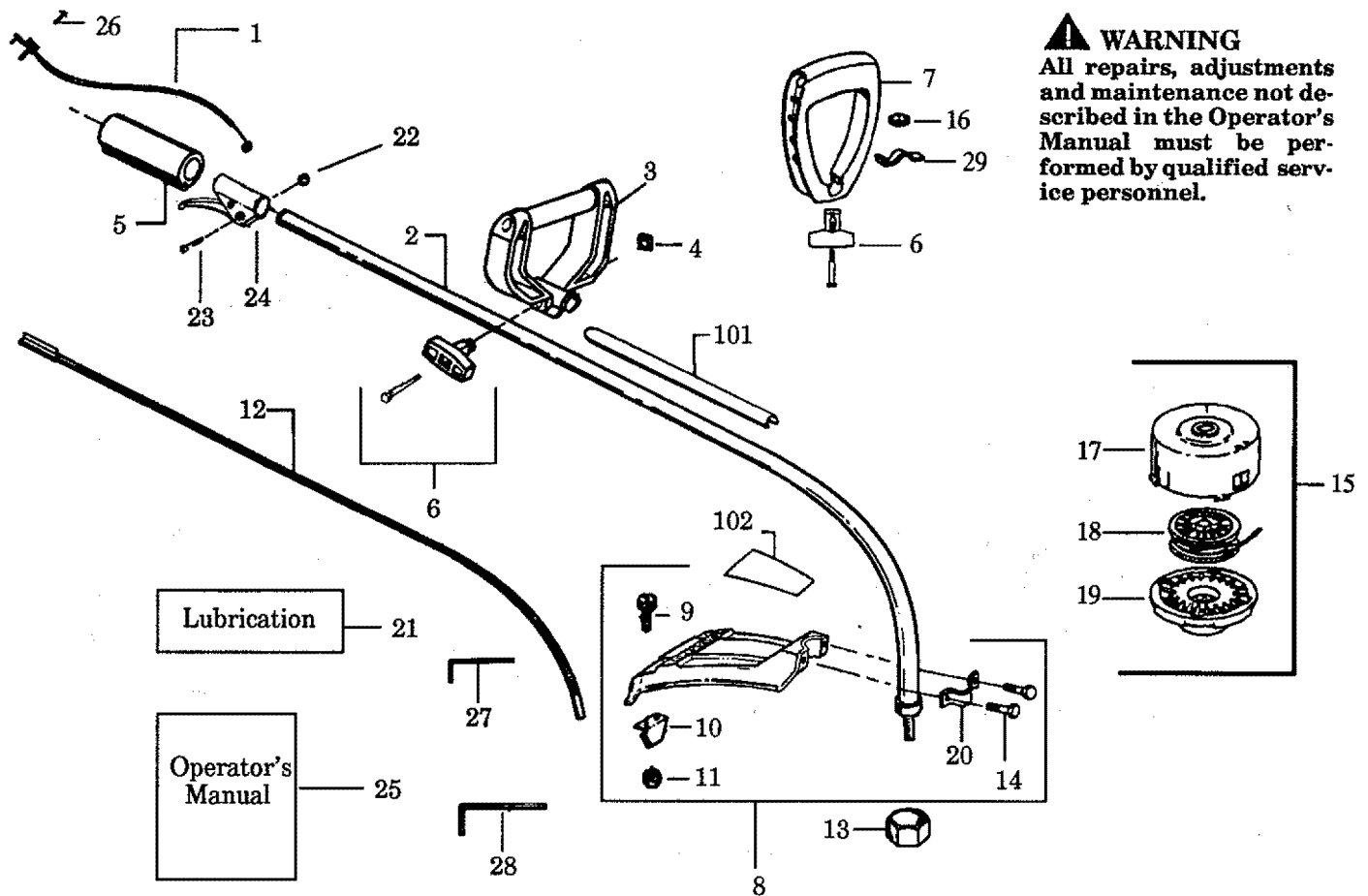

▲ WARNING
 All repairs, adjustments and maintenance not described in the Operator's Manual must be performed by qualified service personnel.

Key No.	Part No.	Description	Key No.	Part No.	Description
1	530-027549	Throttle Cable Ass'y.	17	530-094592	Hub Ass'y.
2	530-094692	Drive Shaft Housing	18	71-85815	Spool w/Line
3	530-010957	Handle	19	530-094494	Cover
4	STD541025	Locknut	20	530-093653	Bracket
5	530-027595	Drive Shaft Grip	21	952-030139	Shaft Lubrication
6	530-069252	"T" Handle Kit	22	530-015768	Nut
7	530-014222	Handle Ass'y.	23	530-015774	Screw
8	530-069280	Shield Kit Ass'y. (Incl. #9,10,11,14 & 23)	24	530-010959	Throttle Lever Ass'y.
9	STD511005	Screw	25	530-067910	Operator's Manual
10	530-094570	Line Limiter	26	530-015775	Screw
11	STD541410	Nut	27	530-031111	Hex Wrench (5/32)
12	530-094551	Flexible Drive Shaft	28	530-031098	Hex Wrench (3/16)
13	530-094543	Dust Cup	29	530-094742	Clamp
14	530-092243	Screw			
15	71-85805	Cutting Head Ass'y.			
16	530-015610	Nut	101	530-027430	Shaft Warning Decal
			102	530-029298	Shield Decal

SEARS WEEDWACKER® REPAIR PARTS LIST - 358.797180-26.0cc

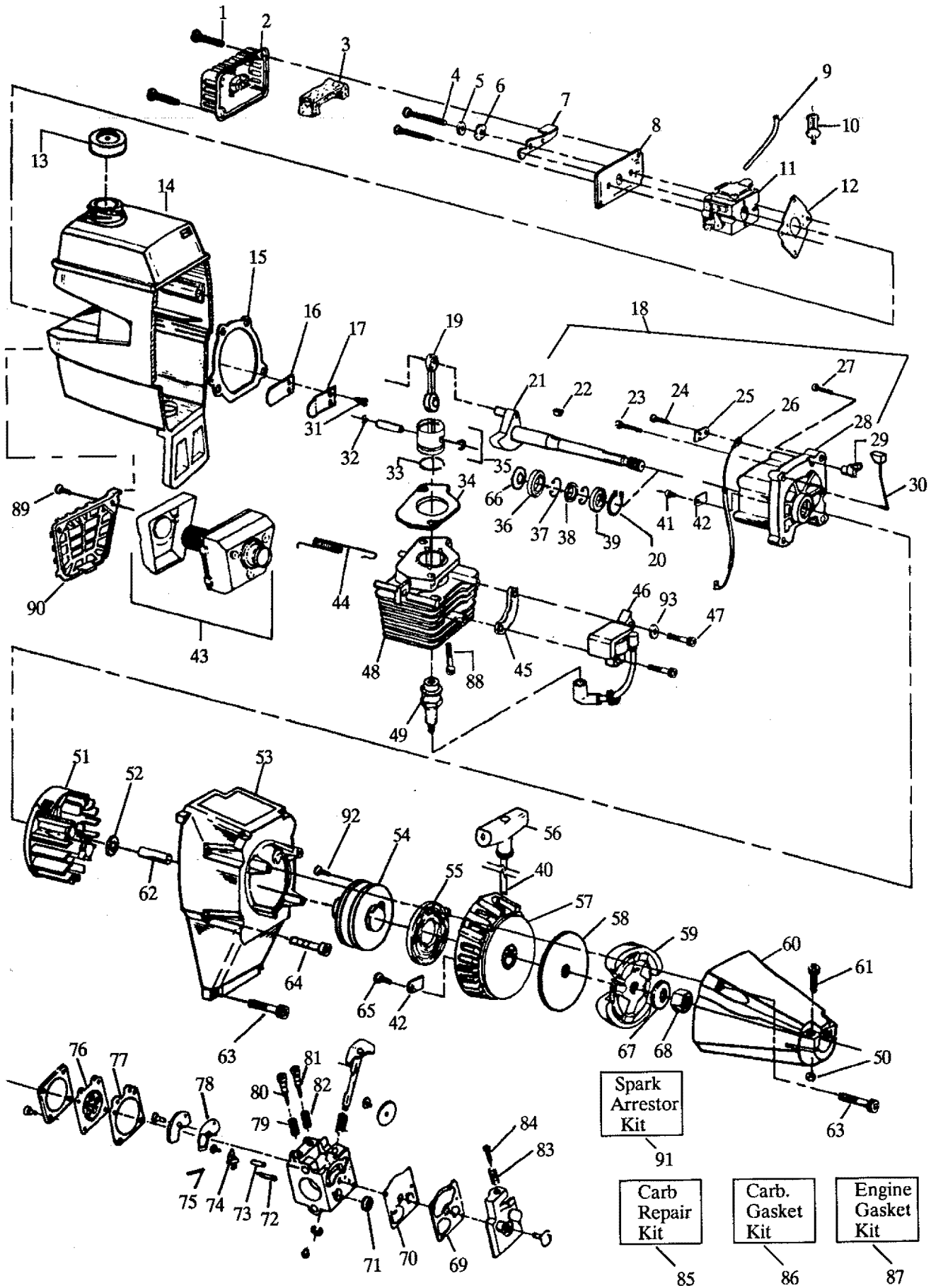

SEARS WEEDWACKER® REPAIR PARTS LIST - 358.797180-26.0cc

Key No.	Part No.	Description	Key No.	Part No.	Description
1	530-015773	Screw	50	530-015768	Locknut
2	530-027529	Air Filter Cover	51	530-039136	Flywheel Ass'y.
3	530-027530	Air Filter	52	530-347987	Washer
4	530-015766	Screw	53	530-027517	Fan Housing
5	530-027528	Spacer	54	530-069291	Starter Pulley Kit (Incl. #92)
6	530-015254	Wave Washer	55	530-029395	Starter Spring
7	530-027526	Choke Shutter	56	530-027569	Starter Handle
8	530-027527	Air Filter Plate	57	530-010961	Pulley Housing Ass'y.
9	530-069247	Fuel Line Kit	58	530-094189	Clutch Washer
10	530-010897	Fuel Pick-up Ass'y.	59	530-069254	Clutch Ass'y. Kit
11	530-035259	Carburetor	60	530-010964	Clutch Housing
12	530-019156	† Carburetor Gasket	61	530-015767	Screw
13	530-010729	Fuel Cap Ass'y.	62	530-027511	Spacer
14	530-027606	Shroud & Tank Ass'y. (Incl. #9,10 & 13)	63	530-015770	Screw
15	530-019154	† Crankcase/Shroud Gasket	64	530-015769	Screw
16	530-027593	Reed	65	530-015496	Screw
17	530-027594	Reed Stop	66	530-015788	Spacer
18	530-014015	Crankcase/Crankshaft Ass'y. (Incl. #20,21,28)	67	530-015796	Washer
19	530-010960	Connecting Rod Ass'y. (Incl. Bearings)	68	STD541137	Nut
20	530-015789	Crankshaft Retaining Ring	69	530-035164	*+ Pump Gasket
21	530-010934	Crankshaft Ass'y.	70	530-035166	*+ Pump Diaphragm
22	530-015126	Flywheel Key	71	530-035178	+ Inlet Screen
23	530-015772	Screw	72	530-035106	+ Inlet Needle Valve
24	530-015780	Screw	73	530-035188	+ Metering Lever Spring
25	530-027546	Switch Insulator	74	530-035031	+ Metering Lever
26	530-027547	Lead Wire	75	530-035028	+ Metering Pin
27	530-015771	Screw	76	530-035014	*+ Metering Diaphragm
28	530-014016	Crankcase Ass'y.(Incl. # 36-39)	77	530-035151	*+ Metering Diaphragm Gasket
29	530-027545	Switch Ramp	78	530-035147	*+ Circuit Plate Gasket
30	530-027543	Switch Spring Ass'y.	79	530-035036	Hi Speed Needle Spring
31	STD610603	Screw	80	530-035142	Hi Speed Needle
32	530-015162	Piston Pin Retainer	81	530-035141	Idle Needle
33	530-027369	Piston Ring	82	530-035023	Idle Needle Spring
34	530-019178	† Cylinder Gasket	83	530-035208	Idle Speed Spring
35	530-069240	Piston Kit (Incl. #32,33, & pin)	84	530-035203	Idle Speed Screw
36	530-032103	Inner Bearing	85	530-035260	Carb. Kwik Repair Kit (+ Indicates Contents)
37	530-015787	Retaining Ring	86	530-035186	Carb. Gasket/Diaphragm Kit (*Indicates Contents)
38	530-019158	Crankshaft Seal	87	530-069276	Engine Gasket Kit (†Indicates Contents)
39	530-032102	Bearing Outer	88	530-015239	Screw
40	530-069232	Rope Kit	89	530-015717	Screw
41	530-015777	Screw	90	530-027781	Muffler Guard
42	530-027523	Retainer	91	952-701612	Spark Arrestor Kit
43	530-069257	Muffler Kit	92	530-015823	Screw
44	530-024903	Muffler Attachment Spring	93	530-015811	Screw
45	530-027525	Spacer			
46	530-039134	Ignition Module Kit			
47	530-015776	Screw			
48	530-012247	Cylinder			
49	530-030077	Spark Plug			
			Not Shown		
				530-029731	Instruction Decal
				530-061273	Carton
				530-014223	Ass'y. Parts Bag

INDEX

ACCESSORIES	10	LUBRICATION	
ADJUSTMENTS		Engine	11
Assist Handle	9	Flexible Drive Shaft	19
Carburetor	20	MAINTENANCE	
Line Advance	14	Air Filter	17
Module Air Gap	2	Carburetor	20
Spark Plug Gap	2	Flexible Drive Shaft	19
AIR FILTER	17	Safety	17
ASSEMBLY		Starter Rope	18
Assist Handle	9	Trimmer Head	16
Drive Shaft Housing	7	Trouble Shooting Chart	22
Preparation	7	MODULE AIR GAP	2
Shield	9	OIL, ENGINE	
Throttle Cable	8	Ratio to Gasoline	11
Trimmer Head	8	Types to Use; not to Use	11
CARBURETOR ADJUSTMENTS	20	OPERATION	
CARTON CONTENTS	6	Advancing the Line	14
COLD ENGINE STARTING	12	Mowing	15
CONTROLS	2	Pre-Operation Checks	12
CUTTING METHODS	15	Position	10
DRIVE SHAFT HOUSING ASSEMBLY	7	Safety	14
ENGINE		Scalping	15
Air Filter	17	Starting the Engine	12
Carburetor	20	Speed	13
Controls	2	Stopping the Engine	13
Fuel Mixture	11	Sweeping	15
Starter Pulley	18	Trimming	15
Starting Instructions	12	PARTS LIST	23
Storage	5	PRE-OPERATION CHECKS	12
Trouble Shooting	22	PREWOUND SPOOLS	16
ENGINE OIL		QUICK REFERENCE PAGE	27
Ratio to Gasoline	11	REPAIR PARTS LIST	23
Types to Use; not to Use	11	SAFETY INSTRUCTIONS, WARNINGS	3 & 5
FILTER, AIR	17	SHIELD ASSEMBLY	9
FLEXIBLE DRIVE SHAFT LUBRICATION	19	SPARK PLUG GAP	2
FUEL		SPARK ARRESTOR	6
Gasoline/Oil Mixture	11	SPECIFICATIONS	2
Mixing Fuel	11	SPOOL	
Pouring Fuel	11	Installation	16
Safety	11	Maintenance	16
Storage	11	Prewound	16
GASOLINE		Rewinding	17
Ratio to Oil	11	STARTER ROPE REPLACEMENT	18
Types to Use; not to Use	11	STARTING INSTRUCTIONS	12
IDLE SPEED ADJUSTMENT	20	STORAGE	5,22
LINE		THROTTLE CABLE ASSEMBLY	8
Advance	14,22	TRIMMER HEAD	
Breaking	17,22	Assembly	8
Length to Cut as Replacement	17	Line Routing	16
Replacement	16	Removal	8
Rewinding on Spool	17	Maintenance	16
Routing in Head	16	TRIMMER LINE FEED	14
Safety	14	TROUBLE SHOOTING CHART	22
Size to Use	17	WARM ENGINE STARTING	12
Welding on Spool	13,22	WARM ENGINE STARTING AFTER RUNNING	
Trouble Shooting	22	OUT OF FUEL	13
		WARNINGS AND SAFETY INSTRUCTIONS	3 & 5
		WARRANTY	2

QUICK REFERENCE PAGE

*Read and Follow All Warnings, Safety Instructions and Operating Instructions.
Failure to do so can result in serious injury.*

Page No.

PREPARATION 3 & 5

1. Know all warnings and safety instructions in this manual.
2. Wear safety face shield or goggles for eye protection.
3. Dress safely - boots or safety shoes and heavy, long pants.
4. Check tool for worn, loose, missing or damaged parts; repair or replace as necessary before using the tool.
5. Inspect and ensure the area to be cut is safe.
6. Keep children, bystanders, and animals 30 feet (10 meters) away.

FUELING 11

1. Eliminate all sources of sparks or flame where fuel is mixed, poured or stored.
2. Use 40 parts regular unleaded gasoline to 1 part air-cooled, 2-cycle engine oil.
3. Use clean and fresh fuel not over 2 months old.
4. Mix and store fuel in an approved, marked container.
5. Mix and pour fuel in an outdoor area.
6. Move a minimum of 10 feet (3 meters) away from the fuel and fueling site before starting engine.

STARTING THE ENGINE 12

1. Extend line 4-6 inches from the head.
2. Rest the shield on the ground supporting the trimmer head up off the ground away from objects and on-lookers.
3. Keep throttle trigger squeezed fully until engine runs.
4. Pull the starter rope sharply and quickly.

OPERATING THE TOOL 13

1. Do not operate the tool at a higher speed than necessary.
2. Release the throttle trigger and allow the engine to idle when not cutting.
3. Stop the engine by moving the ignition switch to the "Off" position.

MAINTENANCE 17

1. Run fuel out of the unit before storing.
2. Disconnect spark plug before performing maintenance except for carburetor adjustments.
3. Clean air filter frequently but always after 5 tanks of fuel.
4. Store in a dry place out of the reach of children.

SEARS

operator's manual

**MODEL NO.
358.797180-26cc
(17" Cutting Path)**

How to Order Repair parts

**SEARS SERVICE
IS AT YOUR SERVICE**

The Model Number will be found on top of the engine with the Serial Number. Always mention the Model Number when requesting service or repair for your unit.

All parts listed herein may be ordered from any Sears Service Center and most Sears Stores.

WHEN ORDERING REPAIR PARTS GIVE THE FOLLOWING INFORMATION AS SHOWN IN THIS LIST.

- | | |
|-----------------------------------|---|
| 1. The PART NUMBER | 3. The PART DESCRIPTION |
| 2. The MODEL NUMBER
358.797180 | 4. The NAME OF ITEM —
26cc Gas Weedwacker® |

If the parts you need are not stocked locally, your order will be electronically transmitted to a Sears Repair Parts Distribution Center for handling.



When you buy merchandise from Sears you get an extra value that nobody else can offer — Sears Service.

Across town or across the country, Sears Service is always near, providing trustworthy, competent service technicians using only Sears specified factory parts.

Your Sears Merchandise takes on added value when you discover that Sears has Service Units throughout the country. Each is staffed by Sears-Trained, professional technicians using Sears approved methods.

Sears, Roebuck and Co., Chicago, Ill. 60684 U.S.A.