

Owner's Manual

CRAFTSMAN[®]

**46" HIGH PERFORMANCE
LAWNSWEEPER**

Model No. 486.24223

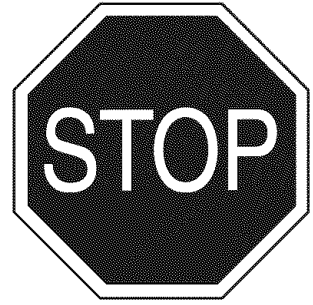

DO NOT RETURN TO STORE
For Missing Parts or Assembly
Questions Call 1-866-576-8388

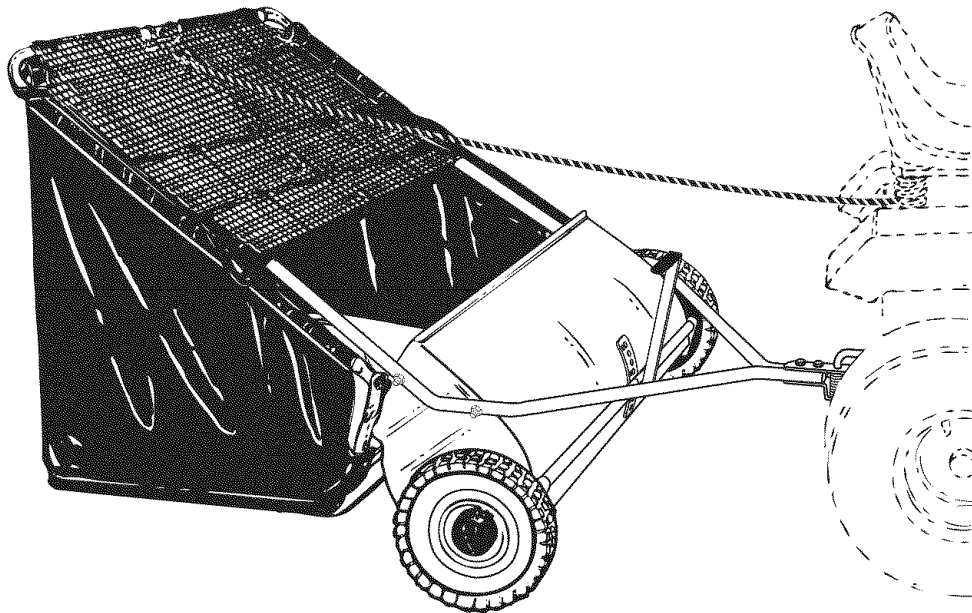

CAUTION:

Before using this product, read this manual and follow all Safety Rules and Operating Instructions.

- Safety
- Assembly
- Operation
- Maintenance
- Parts

Sears, Roebuck and Co., Hoffman Estates, IL 60179 U.S.A.
www.sears.com/craftsman

PRINTED IN U.S.A.

FORM NO. 48742 (3/06)

TABLE OF CONTENTS

Safety Rules	2	Maintenance Schedule	12
Carton Contents	3	Storage	12
Accessories and Attachments	3	Service and Adjustments	13
Full Size Hardware Chart	4	Troubleshooting	13
Sweeper Assembly Instructions	5	Repair Parts Illustration	14
Hopper Assembly Instructions	7	Repair Parts List	15
Operation	11	Parts Ordering/Service	Back Cover

WARRANTY

ONE YEAR FULL WARRANTY

When operated and maintained according to the instructions supplied with it, if this Craftsman Lawnsweeper fails due to a defect in material or workmanship within one year from the date of purchase, call 1-800-4-MY-HOME® to arrange for free repair (or replacement if repair proves impossible).

If this product is used for commercial or rental purposes, this warranty applies for only 90 days from the date of purchase.

This warranty gives you specific legal rights, and you may also have other rights which vary from state to state.

Sears, Roebuck and Co., D817WA, Hoffman Estates, IL 60179



SAFETY



Any power equipment can cause injury if operated improperly or if the user does not understand how to operate the equipment. Exercise caution at all times, when using power equipment.

1. Read the vehicle and sweeper owners manuals and know how to operate your vehicle and sweeper before using this sweeper attachment. Always instruct other users before they operate the sweeper.
2. Do not permit children to operate sweeper.
3. Do not permit anyone to ride on sweeper.
4. Never attach the hopper rope to any part of your body or clothing! Never hold onto the rope while towing the sweeper! Attach the rope to the towing vehicle to keep it away from wheels and rotating parts.
5. Operate the sweeper at reduced speed on rough terrain, near ditches and on hillsides to prevent loss of control.
6. Vehicle braking and stability may be affected with the attachment of this sweeper. Do not fill sweeper to maximum capacity without checking the capability of the towing vehicle to safely pull and stop with the sweeper attached. **Stay off of steep slopes.**
7. Stop and inspect vehicle and sweeper for damage after striking an object. Repair any damage before continuing operation.
8. Keep sweeper away from fire. Excessive heat can damage the brushes and hopper bag and could cause the bag and its contents to burn.
9. Before storing the sweeper, always empty the hopper bag to avoid spontaneous combustion.
10. Follow maintenance and lubrication instructions as outlined in the maintenance section of this manual.



Look for this symbol to point out important safety precautions. It means — **Attention!! Become alert!!** Your safety is involved.

The model and serial numbers will be found on a decal attached to the lawnsweeper.

You should record both the serial number and the date of purchase and keep in a safe place for future reference.

MODEL NUMBER: 486.24223

SERIAL NUMBER: _____

DATE OF PURCHASE: _____

ACCESSORIES AND ATTACHMENTS

These accessories were available when the unit was purchased. They are also available at most Sears retail outlets and service centers. Most Sears stores can order repair parts for you when you provide the model numbers of your tractor and sweeper.

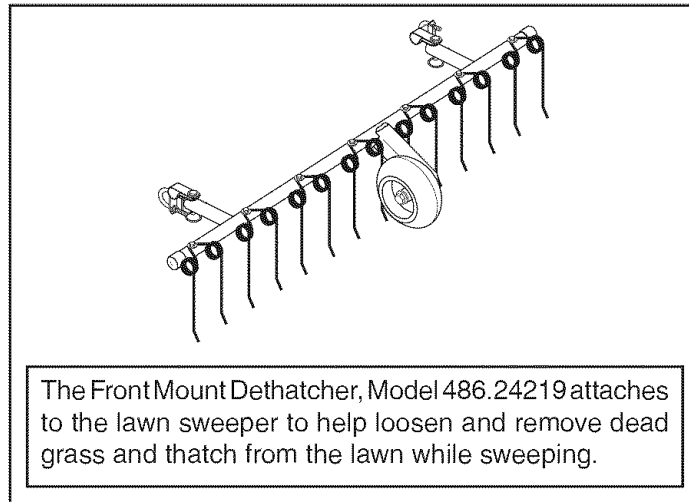

The Front Mount Dethatcher, Model 486.24219 attaches to the lawn sweeper to help loosen and remove dead grass and thatch from the lawn while sweeping.

CARTON CONTENTS (Loose Parts in Carton)

- | | | |
|---------------------------------------|--|------------------------------|
| 1. Sweeper Housing Assembly | 6. Height Adjustment Plate | 11. Rear Hopper Tube (2) |
| 2. Bag Arm Tube (2) | 7. Height Adjustment Handle | 12. Upper Hopper Tube (2) |
| 3. Hitch Tube, Left Hand (Marked 39L) | 8. Hitch Tube, Right Hand (Marked 40R) | 13. Lower Hopper Tube (2) |
| 4. Hitch Bracket Assembly | 9. Rope | 14. Hopper Bag Pivot Rod |
| 5. Hitch Bracket, Bent | 10. Hopper Bag | 15. Hopper Support Strap (2) |
| | | 16. Bag Frame Strap |

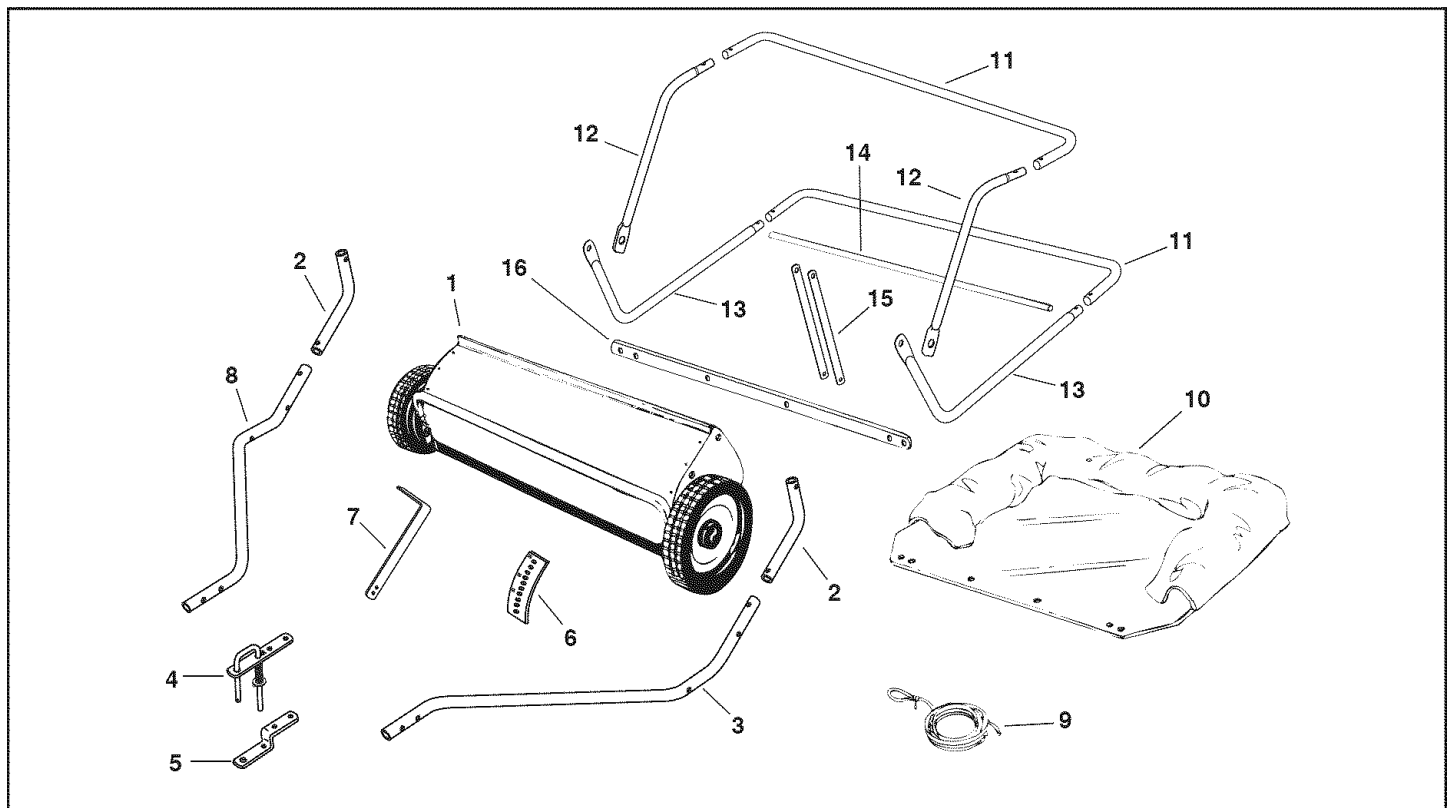

HARDWARE PACKAGE CONTENTS

SHOWN FULL SIZE

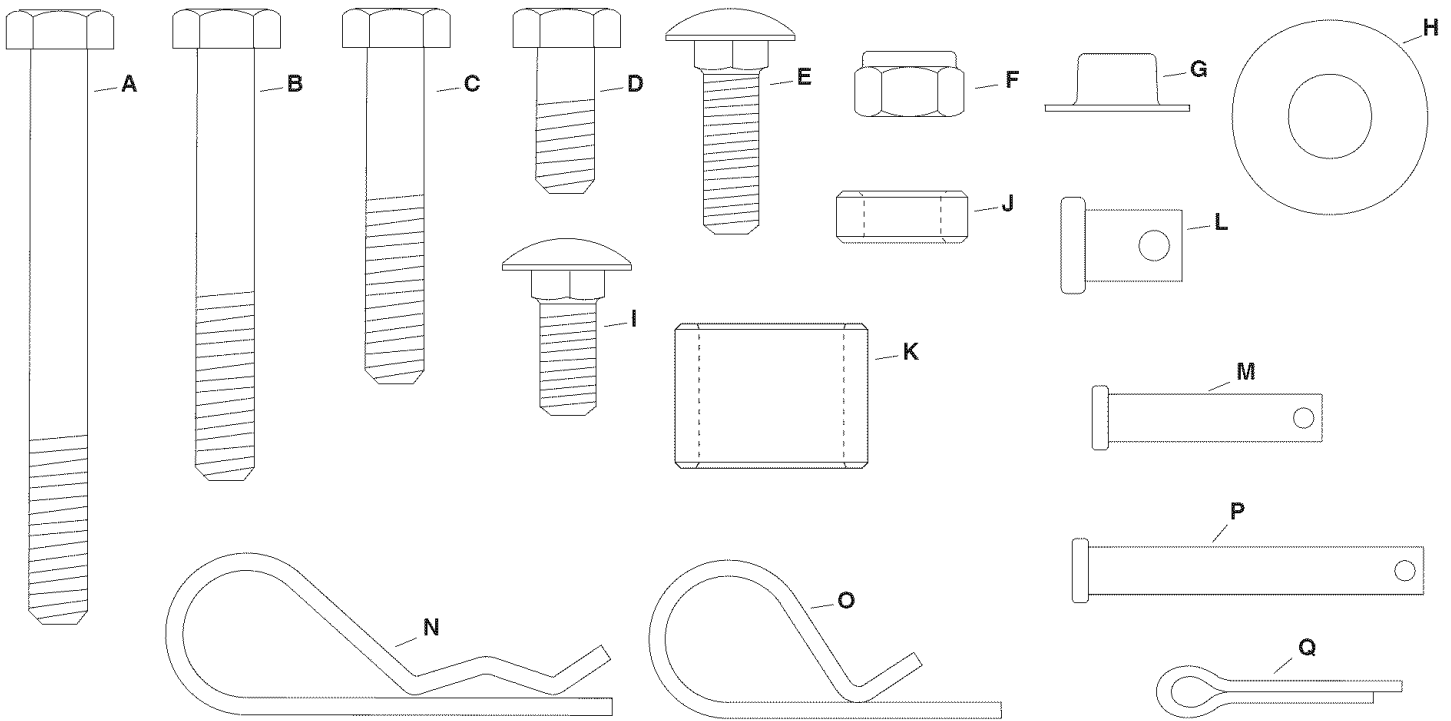

NOT SHOWN FULL SIZE

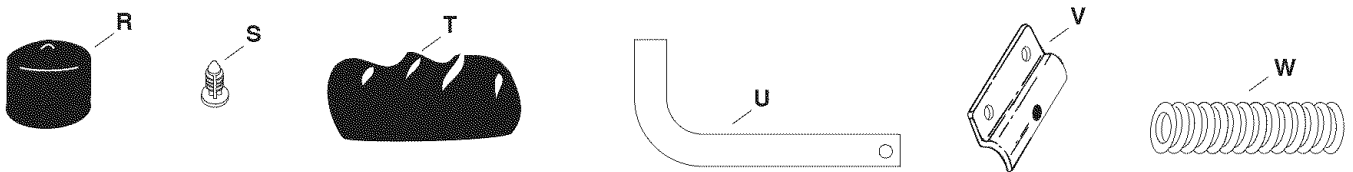

REF.	QTY.	DESCRIPTION	REF.	QTY.	DESCRIPTION
A	2	Hex Bolt, 5/16-18 x 3" Lg.	M	4	Clevis Pin, 1/4" x 1-1/8"
B	2	Hex Bolt, 5/16-18 x 2-1/4" Lg.	N	1	Hairpin Cotter, 1/8"
C	4	Hex Bolt, 5/16-18 x 1-3/4" Lg.	O	8	Hairpin Cotter, 3/32"
D	2	Hex Bolt, 5/16-18 x 3/4"	P	2	Clevis Pin, 1/4" x 1-3/4"
E	3	Carriage Bolt, 5/16-18 x 1" Lg.	Q	1	Cotter Pin, 1/8" x 3/4"
F	17	Nylock Nut, 5/16"	R	2	Vinyl Cap
G	2	Palnut, 3/8"	S	4	Plastic Plug
H	1	Flat Washer, 3/8" Standard	T	1	Grip
I	4	Carriage Bolt, 5/16-18 x 3/4"	U	1	Height Adjustment Pin
J	3	Spacer, .38" x .62" x .27"	V	4	Hopper Clamp
K	2	Hitch Spacer, 3/4"	W	1	Spring
L	2	Clevis Pin, 3/8" x 1/2"			

ASSEMBLY

10"

TOOLS REQUIRED FOR ASSEMBLY

- (1) Pliers
- (1) Hammer
- (2) 1/2" Open End or Box End Wrench
- (1) 1/2" Socket Wrench (recommended)

STEP 1 - REMOVE PARTS FROM CARTON

- To protect painted parts, lay them on cardboard or a mat.
- Remove the sweeper housing, the loose parts and the hardware package from the carton. Lay out the parts and hardware as shown on pages 3 and 4.

STEP 2 - ASSEMBLE HITCH TUBES

- The hitch tubes are stamped with a "39L" for the left tube and a "40R" for the right tube. The sweeper housing is marked with an "L" on the left side and an "R" on the right side. See figure 1.
- Hold the left hitch tube so that the end stamped with "39L" is beside the left side of the sweeper and the front end of the tube angles inward. Attach using two hex bolts (C) and nylock nuts (F). Repeat for the right hitch tube. **Do not tighten yet.** See figure 1.

STEP 3 - REMOVE PLASTIC TIE

- Remove the plastic tie that fastens the height adjustment tube to the front of the sweeper housing. See figure 1.

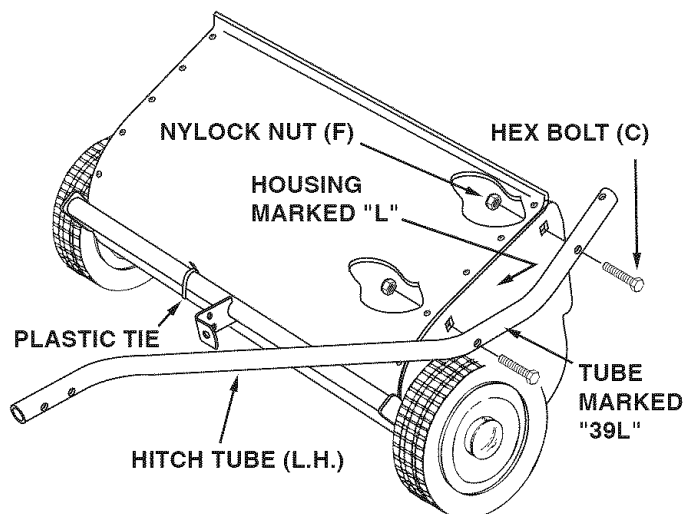

FIGURE 1

STEP 4 - FASTEN HITCH TUBES

- Fasten the hitch tubes together using two hex bolts (A) and nylock nuts (F). **Do not tighten yet.** See figure 2.

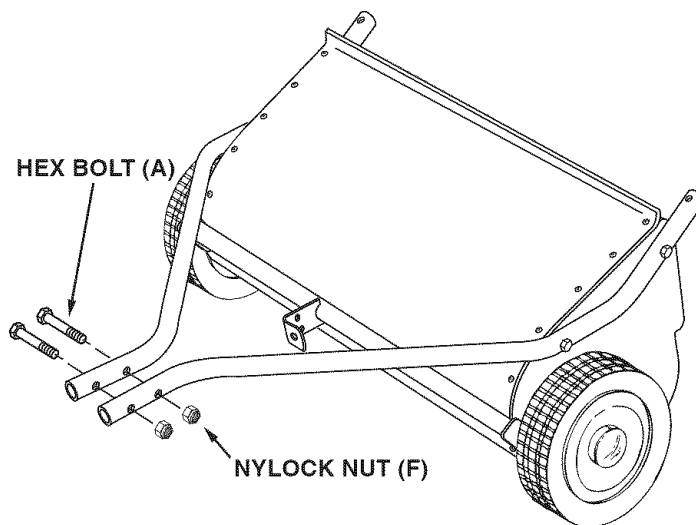

FIGURE 2

STEP 5 - MEASURE TRACTOR HITCH

- Use the mark along the side of this page to measure the height of the tractor hitch. The mark is 10" from the bottom of the page. If the tractor hitch is less than 10" above the ground, go to **STEP 6a**. If the tractor hitch is 10" or more above the ground, go to **STEP 6b**.

STEP 6a - ASSEMBLE HITCH BRACKETS

- If the tractor hitch is less than 10" above the ground, place the bent hitch bracket underneath the hitch tubes and place the hitch bracket assembly on top of the hitch tubes. Insert two hex bolts (B) through the brackets, with the rear hex bolt between the cross bolts in the hitch tubes. Secure the hex bolts (B) with two nylock nuts (F). See figure 3. **Do not tighten yet.**
- Assemble the two spacers (K) onto the hitch pin and secure the pin with the hairpin cotter (N). See figure 3.

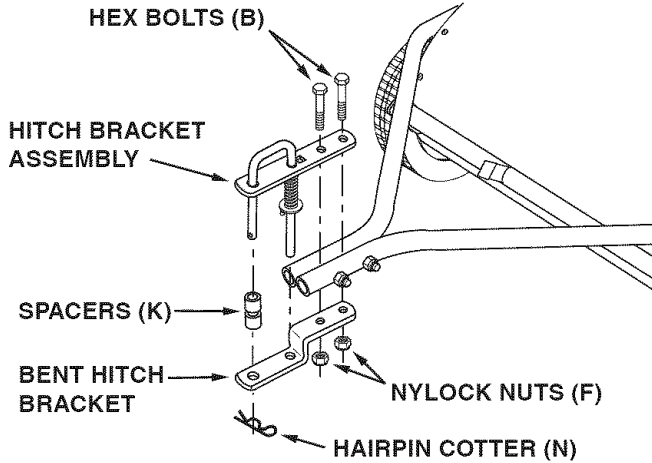

FIGURE 3

STEP 6b - ASSEMBLE HITCH BRACKETS

- If the tractor hitch is 10" or more above the ground, place the bent hitch bracket on top of the hitch tubes and place the hitch bracket assembly underneath the hitch tubes. Insert two hex bolts (B) through the brackets, with the rear hex bolt between the cross bolts in the hitch tubes. Secure the hex bolts (B) with two nylock nuts (F). See figure 4. **Do not tighten yet.**
- Assemble the two spacers (K) onto the hitch pin and secure the pin with the hairpin cotter (N). See figure 4.

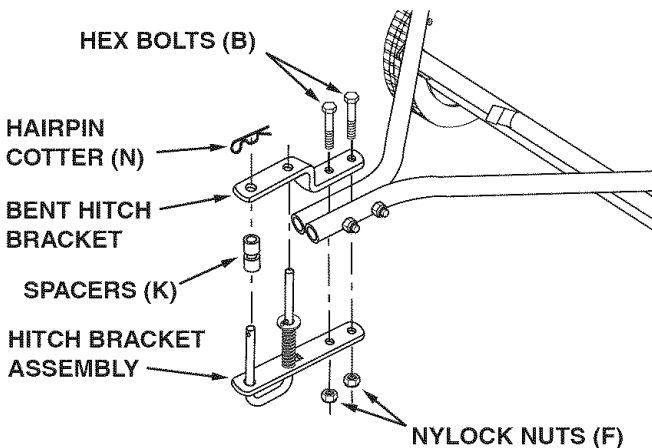

FIGURE 4

STEP 7 - TIGHTEN BOLTS

- **Tighten** the four bolts in figure 1 that fasten the hitch tubes to the sweeper housing. Next, **tighten** the two bolts in figure 2 that fasten the ends of the hitch tubes together. Finally, **tighten** the two bolts in figure 3 or 4 that fasten the hitch brackets to the hitch tubes.

STEP 8 - ATTACH HEIGHT ADJUSTMENT PLATE

- Attach the height adjustment plate to the sweeper housing using three carriage bolts (E), spacers (J) (placed between plate and housing) and nylock nuts (F). See figure 5.

Hint: Push the height adjustment tube down out of the way to allow easier access to holes in sweeper housing.

Hint: Attach the bolts, spacers and nuts to one hole at a time starting with the top hole to ease assembly.

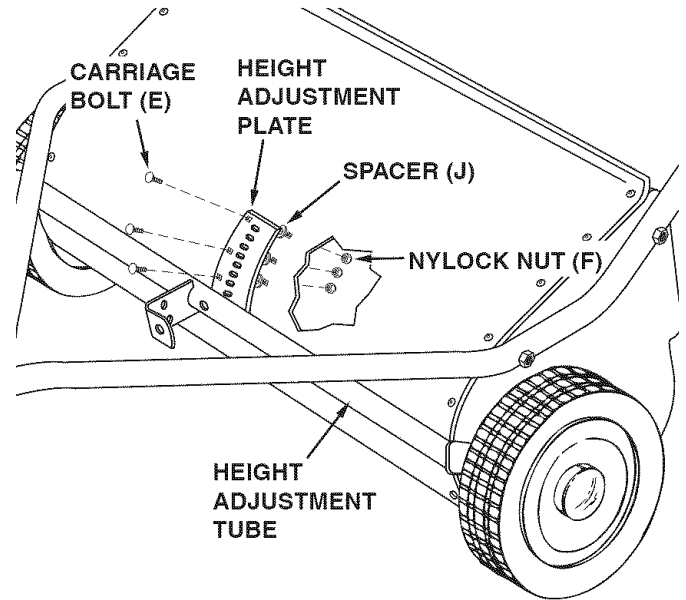

FIGURE 5

STEP 9 - ATTACH HANDLE

- Assemble the height adjustment handle to the height adjust bracket at the front of the sweeper housing. Use two hex bolts (D) and nylock nuts (F) to the bracket. See figure 6.
- Assemble the grip (T) onto the end of the height adjustment handle as shown in figure 6.

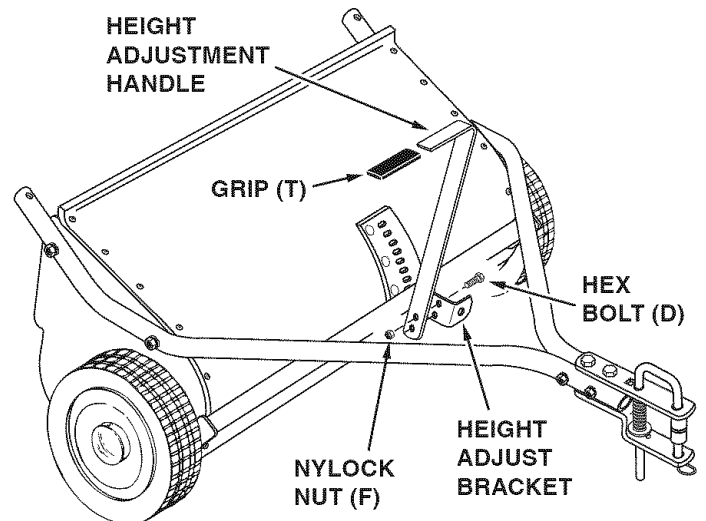

FIGURE 6

STEP 10 - ASSEMBLE HEIGHT ADJUSTMENT PIN

- Place the height adjustment pin (U) into the height adjust bracket. Assemble a spring (W) and washer (H) onto the height adjustment pin (U) and then secure them using a cotter pin (Q). See figure 7.

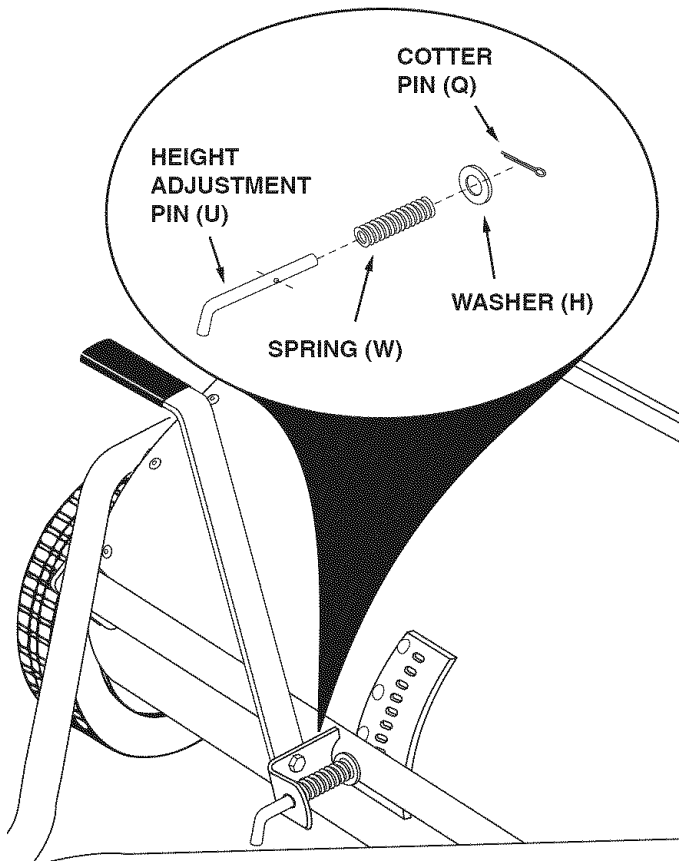

FIGURE 7

STEP 11 - ASSEMBLE UPPER TUBES

- Fit the ends of the two upper hopper tubes into the ends of a rear hopper tube. Align the holes in the ends of the tubes and insert plastic plugs (S). See figure 8.

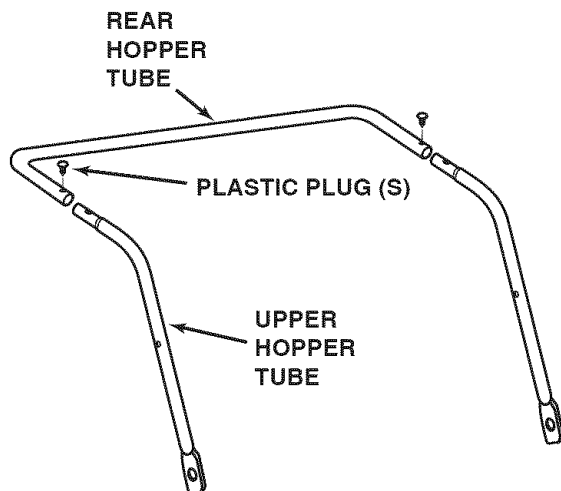

FIGURE 8

STEP 12 - ASSEMBLE LOWER TUBES

- Fit the ends of the two lower hopper tubes into the ends of a rear hopper tube. Align the holes in the ends of the tubes and insert plastic plugs (S). See figure 9.

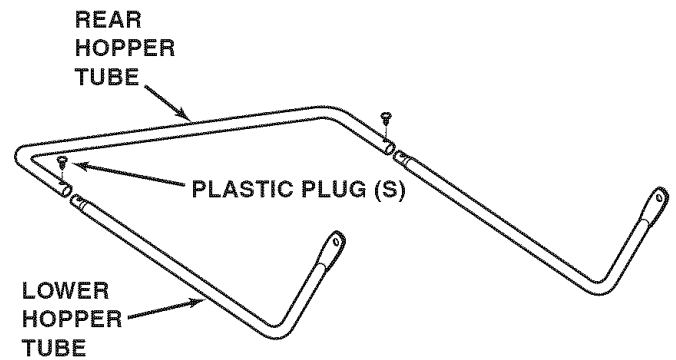

FIGURE 9

STEP 13 - ASSEMBLE TUBES TO BAG

- Unfold the hopper bag, reversing the mesh wind screen and then lay the bag out flat with the wind screen on top.
- Insert the ends of the assembled upper hopper tubes down through the stitched sleeves in the sides of the hopper bag and then slide the tubes back underneath the wind screen. See figure 10.

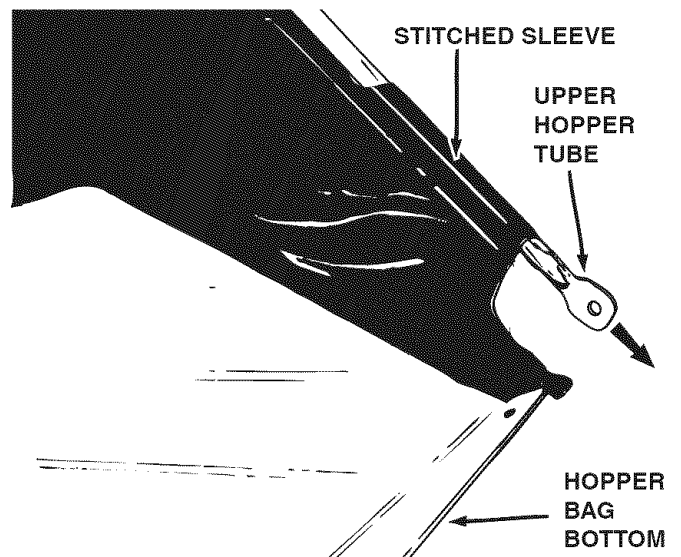

FIGURE 10

- Place the assembled lower hopper tubes into the bottom of the hopper bag and then slide the tubes to the back of the bag. See figure 11.
- Attach the ends of the lower hopper tubes to the **inside** of the upper hopper tubes using two clevis pins (L) inserted from the inside, and two hair cotter pins (O). See figure 11.

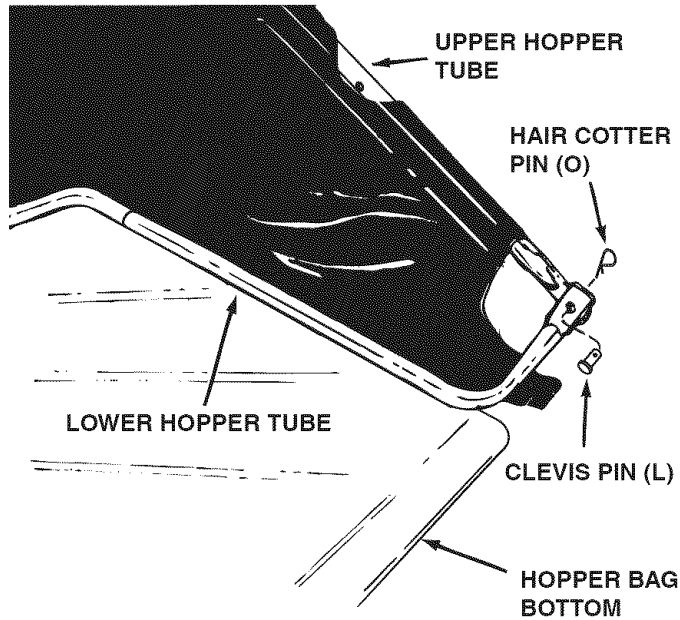

FIGURE 11

STEP 14 - ATTACH BAG BOTTOM

- Insert the bag frame strap into the stitched sleeve at the front edge of the bag bottom. See figure 12.

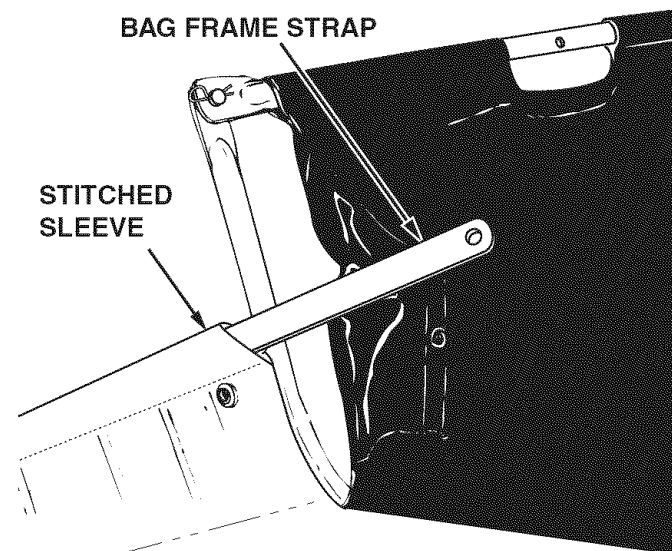

FIGURE 12

- Assemble the bag frame strap to the holes in the lower hopper tubes using two clevis pins (M) and hair cotter pins (O). See figure 13.

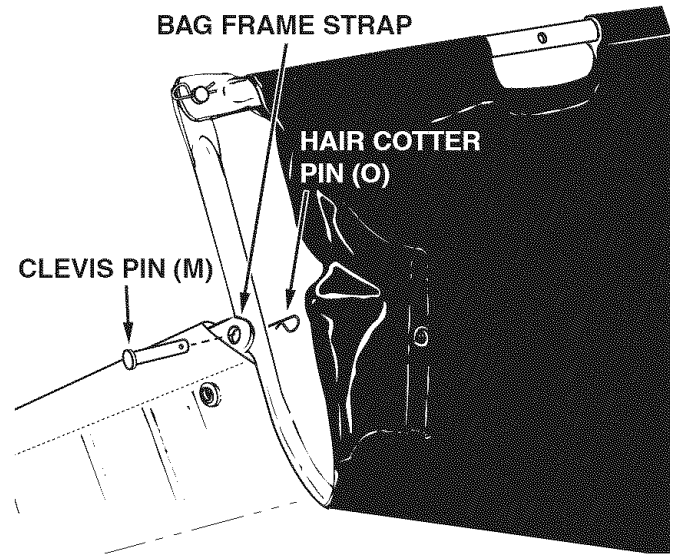

FIGURE 13

- Fold the bag flaps around the lower hopper tubes and attach to the bag bottom using the snaps. See figure 14.

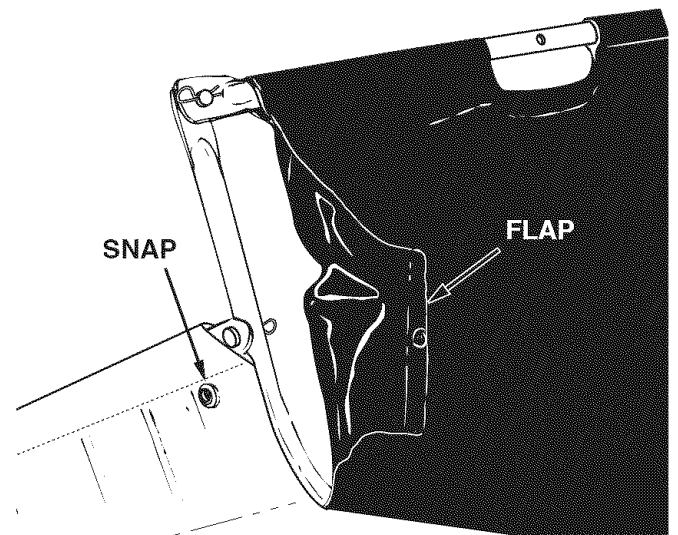

FIGURE 14

STEP 15 - ASSEMBLE PIVOT ROD

- Attach the hopper support straps (end with smaller hole) to the lower hopper tubes using a clevis pin (M) and hair cotter pin (O) for each strap. See figure 15.

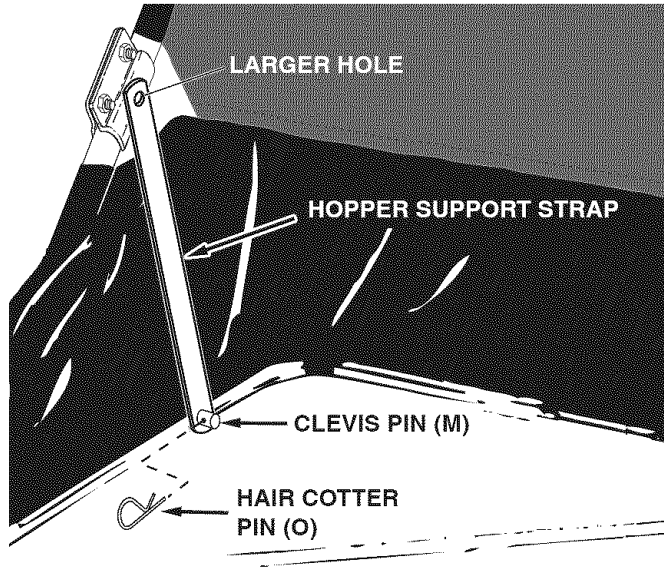

FIGURE 15

- Slide the end of the hopper bag pivot rod through one upper hopper tube with hopper mount clamps. Place the hopper support strap and a bag arm tube onto the rod. Slide rod through the stitched sleeve at the front edge of the wind screen. Place the other bag arm tube and hopper support strap onto the rod. Slide the end of the rod through the other upper hopper tube with hopper mount clamps. See figure 16.
- Assemble two palnuts (G) by lightly tapping them onto the ends of the pivot rod with a hammer. See figure 16.
- Assemble a vinyl cap (R) onto each bag arm tube as shown in figure 16.

HINT: To ease assembly of the palnuts, place the bag on its side on a solid surface. With the bottom end of the pivot rod against the surface, tap a palnut onto the top end of the rod. Repeat for other end of rod.

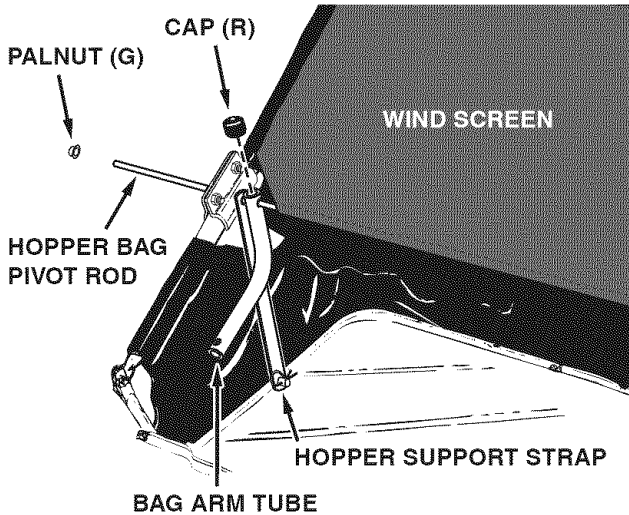

FIGURE 16

STEP 16 - ATTACH ROPE

- Secure the rope to the center of the upper rear hopper tube as shown in figure 17.



FIGURE 17

STEP 17 - ATTACH HOPPER BAG

- To attach the hopper bag to the sweeper, slide the ends of the bag arm tubes into the ends of the hitch tubes and secure with two clevis pins (P) and hairpin cotters (O). See figure 18.

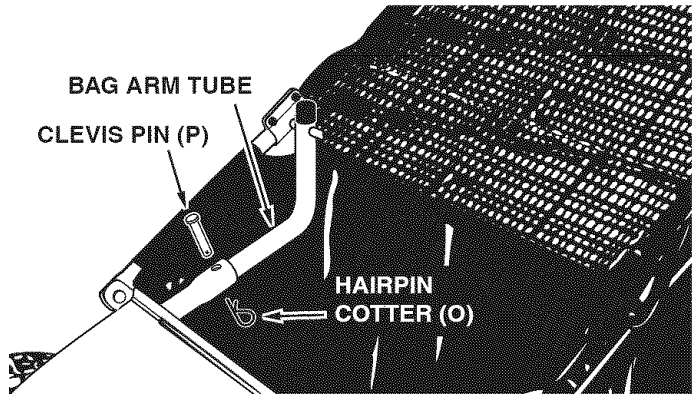

FIGURE 18

ATTACHING SWEEPER HITCH TO TRACTOR

- Place the tractor and sweeper on a flat level surface.
- Set the sweeper height adjustment handle to about the middle of its adjustment range.
- Attach the sweeper hitch to the tractor hitch, arranging the 3/4" spacers in one of six possible combinations as shown in GROUP A and GROUP B diagrams below.

IMPORTANT: To obtain the best performance from your sweeper, arrange the spacers so that the sweeper bag is approximately level with the ground and approximately 5" to 7" off the ground as shown in figure 19.

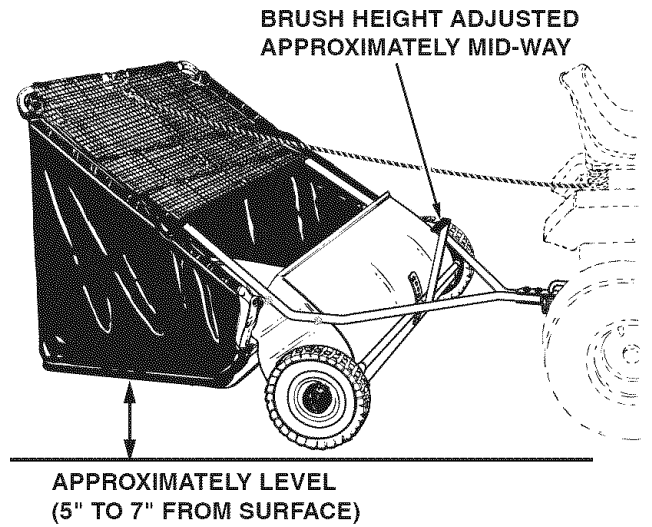
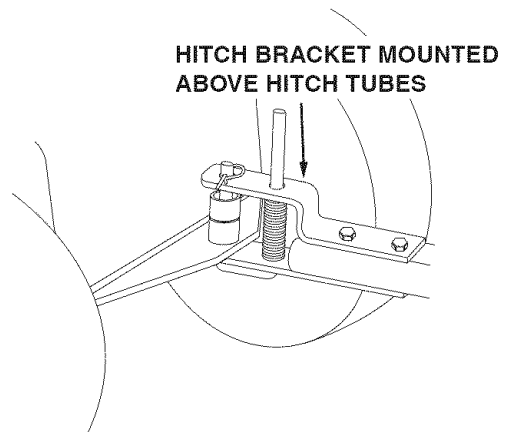
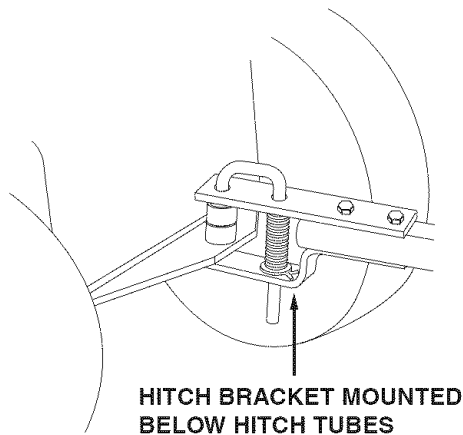

FIGURE 19

GROUP "A" - For vehicles with hitches having 8" to 10" ground clearance.

GROUP "B" - For vehicles with hitches having 10" to 13" ground clearance.



BLACK LINE IS TRACTOR HITCH

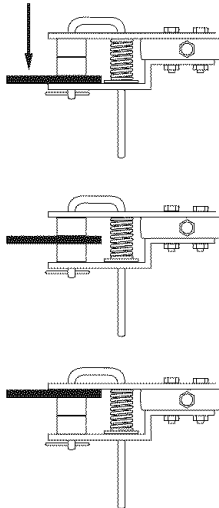

BLACK LINE IS TRACTOR HITCH

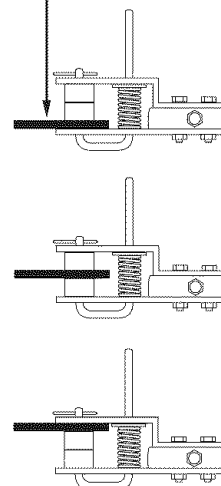

OPERATION

KNOW YOUR SWEEPER

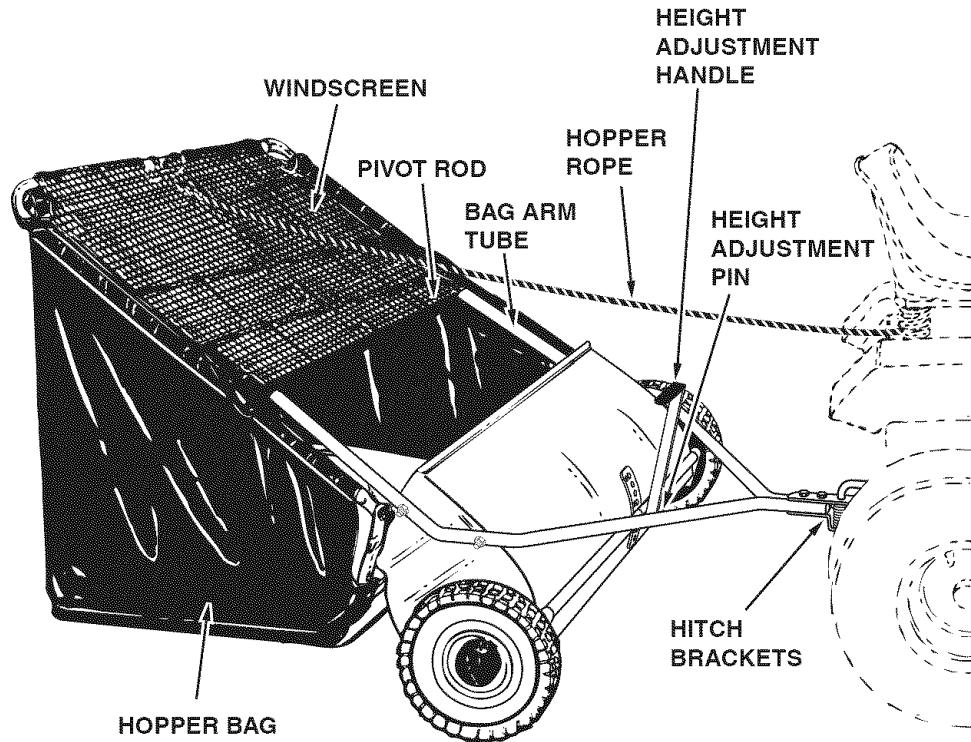

Hopper Bag	Collects grass clippings, leaves and debris.
Hopper Rope	Permits dumping of hopper bag from driver's seat.
Windscreen	Helps prevent collected material from being blown out of hopper bag.
Bag Arm Tubes	Connects the hopper bag to the sweeper housing.
Pivot Rod	Allows hopper bag to tilt forward to dump material.
Height Adjustment Handle	Adjusts the operating height of the sweeper.
Height Adjustment Pin	Holds the height adjustment handle in position when locked.
Hitch Bracket	Connects the sweeper to the towing vehicle. Adjusts for various height tractor hitches.

HOW TO USE YOUR SWEEPER

BRUSH HEIGHT ADJUSTMENT

- To adjust your sweeper brushes to the best operating height, pull out on the height adjustment pin and push down on the height adjustment lever to raise the brush, or push up on the lever to lower the brush. See figure above. Best adjustment is when the brush setting is 1/2" down into the grass. Always mow the grass to an even height before sweeping.

SWEEPING SPEED

- Try a starting speed of approximately 3 m.p.h. (third gear on most tractors). Depending on the conditions, it may be necessary to adjust the sweeping speed in order to achieve best results.

DUMPING OF SWEEPER

- Your sweeper can be dumped easily without getting off of the rider or tractor. Simply pull the rope forward to dump the hopper. Always empty hopper after each use.



CAUTION: Never attach the hopper rope to any part of your body or clothing! **Never hold onto** the rope while towing the sweeper! **Attach the rope** to the towing vehicle to keep it away from wheels and rotating parts.



CAUTION: Keep sweeper away from fire. Excessive heat can damage the brushes and hopper bag and could cause the bag and its contents to burn.

MAINTENANCE

CUSTOMER RESPONSIBILITIES

- Read and follow the maintenance schedule and the procedures listed in the maintenance section.

MAINTENANCE SCHEDULE Fill in dates as you complete regular service.	Service Dates																							
	Before each use	After each use	Twice a year	Every season	Before storage	Every two years																		
Check for loose fasteners	X																							
Check for worn or damaged parts	X			X																				
Lubricate brush shaft bearings			X																					
Lubricate wheel bearings				X																				
Clean Sweeper		X			X																			
Clean/Lubricate chain and sprockets						X																		

SCHEDULED MAINTENANCE

- Clean the sweeper after each use.
- Inspect for worn or damaged parts, such as brushes and wheels.
- Lubricate the brush shaft bearing twice a year with a few drops of light weight oil. See figure 20.

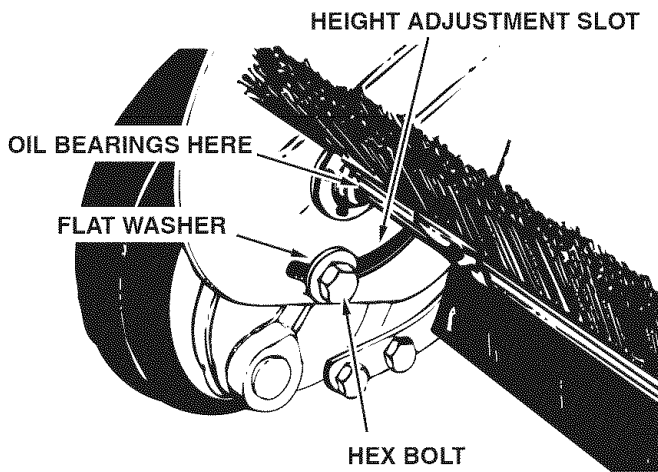

FIGURE 20

- Every two years, remove the wheels and clean the sprockets, chains and gears found inside the wheel housing. After cleaning, lubricate with an even coat of light grease. To remove the wheel, pop off the hub cap using a screwdriver and remove the lock nut and flat washer. See figure 21.

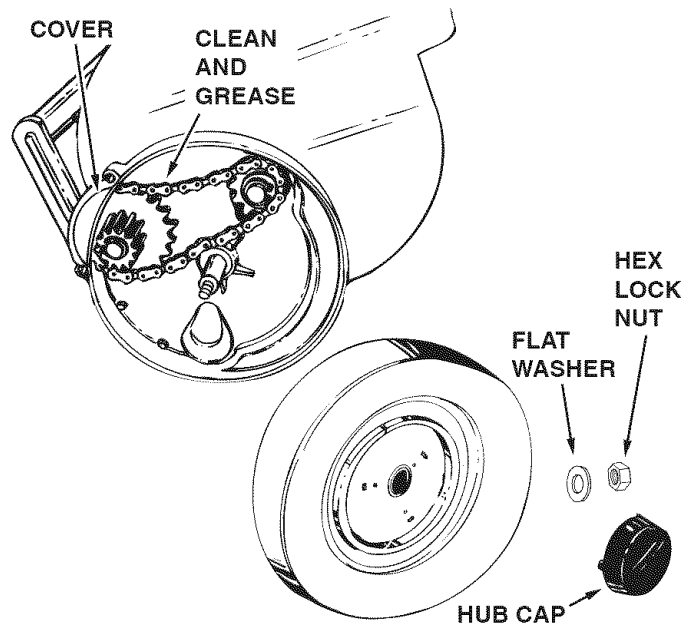

FIGURE 21

CLEANING

- Clean sweeper housing with a soft brush or cloth.
- Clean debris from hopper bag with a brush or broom.
- Remove any material which has wrapped around brushes or ends of brush shaft.

STORAGE



CAUTION: Before storing the sweeper, always empty the hopper bag to avoid spontaneous combustion.

- Clean the sweeper and hopper bag thoroughly to help prevent rust and mildew.
- To collapse the hopper bag for storage, remove the two hopper support rods from the rear of the hopper.
- Store in a dry area.

SERVICE AND ADJUSTMENTS

BRUSH REPLACEMENT

NOTE: Brush replacement should be done one brush at a time.

- Remove the hopper bag from the sweeper.
- Loosen the hex bolts and lock nuts on two single brush retainers which clamp one brush to the double brush retainers. **Do Not loosen** or remove the bolts which fasten the double brush retainers to the brush shaft. See figure 22.
- Slide the brush out of the retainers, noting on which side of the brush the bristles overlap. See figure 22.
- Install new brush, making sure the bristles overlap on the same side of the brush as before. See figure 22.

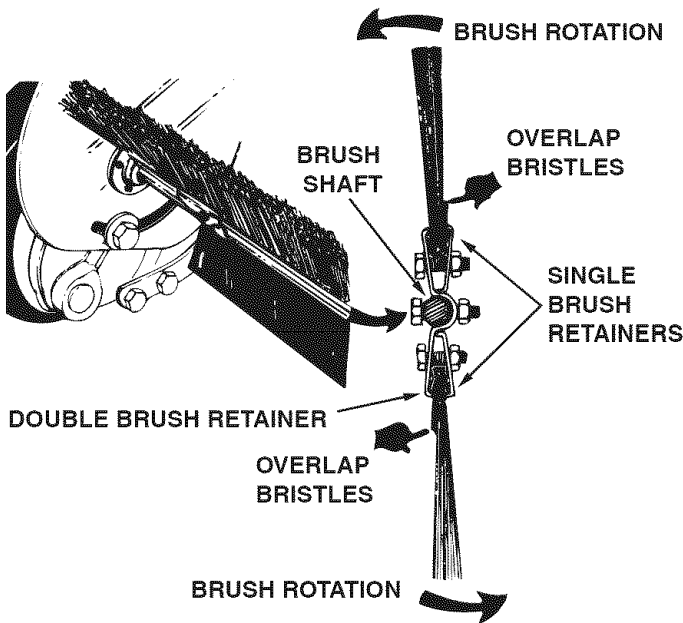

FIGURE 22

SPROCKET, CHAIN AND PAWL SERVICE

IMPORTANT: Do not remove both wheels at the same time to avoid mixing of parts. (The R.H. and L.H. ratchet sprockets are not interchangeable.) **Make notes** on the position of washers and snap rings during disassembly.

- Remove the dust cover by removing the two rivets which fasten it to the wheel housing. (It is not necessary to remove the dust cover if you are only cleaning and lubricating the chain and sprockets.)
- Remove the retaining rings and washers which hold the sprockets onto the shafts.
- Remove the chain and both sprockets, holding them in position and sliding them off both of the shafts. (Look for the drive pin, which may fall out of the brush shaft when the ratchet sprocket is removed.) See figure 23.
- To reassemble, insert the drive pin through the hole at the end of the brush shaft. Make sure the pin slides back and forth easily in the shaft.
- Lightly grease both shafts and the chain, and fill the ratchet sprocket with grease. Assemble the chain with both sprockets back onto the shafts.
- Lightly grease the axle and then reassemble the wheel. The brushes should rotate **only** during forward rotation of the wheel. If the brushes are driven (rotated) by both forward and reverse rotation of the wheel, the drive pin is jamming in the ratchet gear. Disassemble, clean and lubricate the drive pin and ratchet gear.

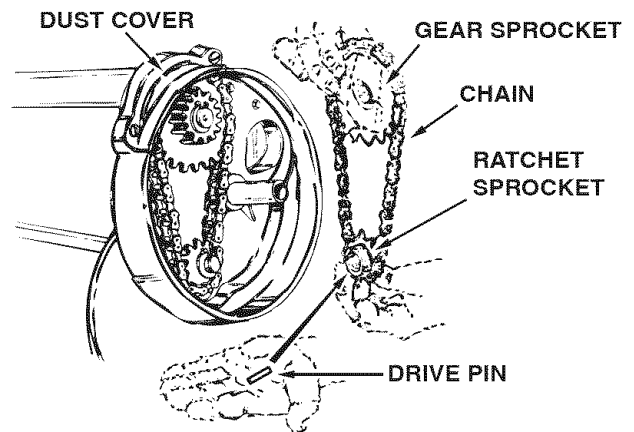

FIGURE 23

TROUBLESHOOTING

<p>Wheels skid when sweeping.</p>	<ul style="list-style-type: none"> • Brushes set too low. • Brushes are jammed • Wheels are jammed. 	<ul style="list-style-type: none"> • Adjust height till brushes are 1/2" down into grass. • Stop sweeper. Remove obstruction. • Remove one wheel at a time to check for obstruction or damage. Refer to Service and Adjustments section.
-----------------------------------	--	---

PARTS

REPAIR PARTS FOR MODEL 486.24223 46" HIGH PERFORMANCE LAWSWEEPER

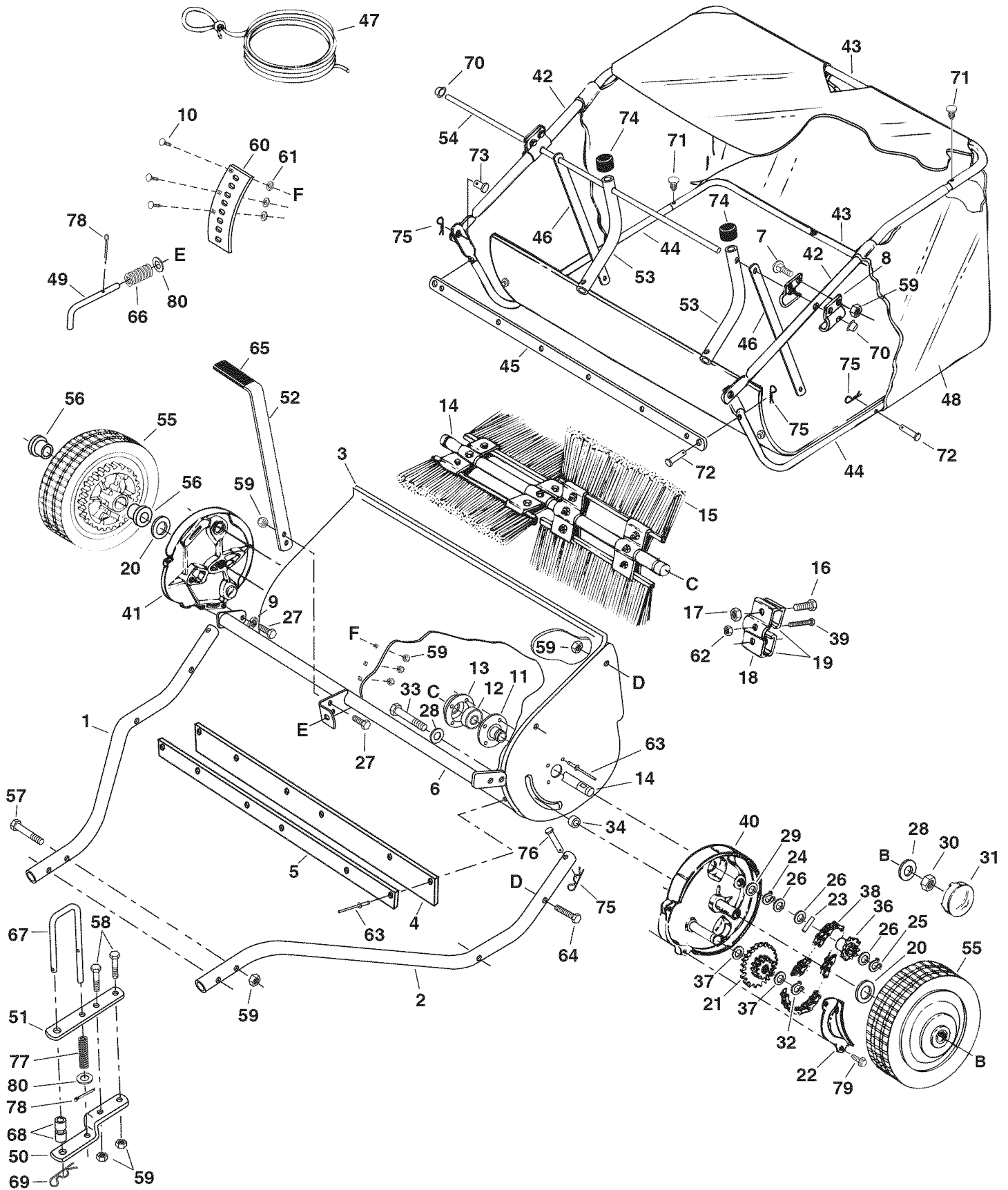

REPAIR PARTS LIST FOR MODEL 486.24223 - 46" HIGH PERFORMANCE LAWSWEEPER

REF. NO.	PART NO.	QTY.	DESCRIPTION	REF. NO.	PART NO.	QTY.	DESCRIPTION
1	48540	1	Hitch Tube, R.H.	43	49616	2	Tube, Rear Hopper Frame
2	48539	1	Hitch Tube, L.H.	44	48726	2	Tube, Lower Hopper Frame
3	64609	1	Housing Assembly	45	25535	1	Strap, Bag Frame
4	48382	1	Skirt, 46"	46	25813	2	Strap, Bag Support
5	24872	1	Retainer, Skirt	47	43737	1	Hopper Rope
6	64610	1	Height Adjustment Tube Ass'y.	48	49767	1	Hopper Bag
7	43080	4	Bolt, Carriage 5/16-18 x 3/4"	49	49608	1	Pin, Height Adjustment
8	23331	4	Clamp, Hopper	50	23687	1	Bracket, Hitch
9	43086	4	Lock Washer, 5/16"	51	24192	1	Bracket, Hitch (Straight)
10	44326	3	Bolt, Carriage 5/16-18 x 1"	52	25537	1	Handle, Height Adjustment
11	62489	2	Brush Bushing Ass'y.	53	49766	2	Tube, Bag Arm
12	44232	2	Ball Bearing	54	49617	1	Rod, Hopper Bag Pivot
13	1629-56	2	Retainer, Dust Cover	55	44985	2	Wheel & Tire Ass'y. (with bearings)
14	25019	1	Brush Shaft	56	45088	4	Wheel Bearing
15	48562	4	Brush, 46"	57	46782	2	Bolt, Hex 5/16-18 x 3" Lg.
16	43012	8	Bolt, Hex 1/4-20 x 3/4" Lg.	58	43224	2	Bolt, Hex 5/16-18 x 2-1/4" Lg.
17	47189	8	Nut, Nylock 1/4-20 Thread	59	47810	17	Nut, Nylock 5/16-18 Thread
18	23580	4	Retainer, Brush (Double)	60	25531	1	Height Adjustment Plate
19	23581	8	Retainer, Brush (Single)	61	23625	3	Spacer, .38" x .62" x .27"
20	44008	2	Washer, Flat 1-1/8" x .78" x .025"	62	47171	4	Nut, Nylock 10-32
21	62490	2	Sprocket / Gear	63	C-9M5732	14	Rivet, Pop
22	23573	2	Dust Cover	64	43084	4	Bolt, Hex 5/16-18 x 1-3/4" Lg.
23	47046	2	Dowel Pin (Drive)	65	43943	1	Grip, Height Adjust
24	43655	2	Ring, Retaining 3/4"	66	HA2394	1	Height Adjust Spring
25	716-0106	2	Ring, Retaining 5/8"	67	49493	1	Pin, Hitch
26	40001	14	Washer, Shim 1-1/8" x .594" x .025"	68	23368	2	Tube, Hitch Spacer
27	43182	6	Bolt, Hex 5/16-18 x 3/4" Lg.	69	43343	1	Hairpin Cotter, 1/8"
28	141	6	Washer, Flat 1-1/2" x .375" x .062"	70	44917	2	Palnut, 3/8"
29	1540-31	4	Washer, Flat .78" x 1.25" x .06"	71	48402	4	Plug, 1/4"
30	1038	2	Nut, Nylock 3/8-24 Thread	72	48365	4	Pin, Clevis 1/4" x 1-1/8"
31	2674-32	2	Hub Cap	73	48366	2	Pin, Clevis 3/8" x 1/2"
32	43894	2	Ring, Retaining 1/2"	74	44481	2	Cap, Vinyl
33	43932	2	Bolt, Hex 3/8-24 x 3-1/2" Lg.	75	43055	8	Hairpin Cotter, 3/32" #3
34	23400	2	Bushing, Spacer	76	46867	2	Pin, Clevis 1/4" x 1-1/2" Lg.
35	43890	1	Sprocket, Ratchet R.H. (not shown)	77	44230	1	Spring, Hitch Pin
36	43889	1	Sprocket, Ratchet L.H.	78	142	2	Pin, Cotter 1/8" x 3/4" Lg.
37	44137	4	Washer, 1/2" x 1" x .02"	79	49102	4	Screw, #12 x 1/2" Hex Head
38	44542	2	Chain, Roller	80	43070	2	Washer, 3/8" Flat
39	49954	4	Screw, Socket HD. #10-32 x 1"		48742	1	Owners Manual
40	62791	1	Housing, Wheel Drive Ass'y. L.H.				
41	62792	1	Housing, Wheel Drive Ass'y. R.H.				
42	49765	2	Tube, Upper Hopper Frame				

Get it fixed, at your home or ours!

Your Home

For repair – **in your home** – of **all** major brand appliances, lawn and garden equipment, or heating and cooling systems, **no matter who made it, no matter who sold it!**

For the replacement parts, accessories and owner's manuals that you need to do-it-yourself.

For Sears professional installation of home appliances and items like garage door openers and water heaters.

1-800-4-MY-HOME® (1-800-469-4663)

Call anytime, day or night (U.S.A. and Canada)

www.sears.com www.sears.ca

Our Home

For repair of carry-in items like vacuums, lawn equipment, and electronics, call or go on-line for the location of your nearest **Sears Parts & Repair Center.**

1-800-488-1222

Call anytime, day or night (U.S.A. only)

www.sears.com

To purchase a protection agreement (U.S.A.) or maintenance agreement (Canada) on a product serviced by Sears:

1-800-827-6655 (U.S.A.)

1-800-361-6665 (Canada)

Para pedir servicio de reparación a domicilio, y para ordenar piezas:

1-888-SU-HOGAR®

(1-888-784-6427)

Au Canada pour service en français:

1-800-LE-FOYER^{MC}

(1-800-533-6937)

www.sears.ca

The Sears logo is centered at the bottom of the page. It features the word "Sears" in a bold, serif font. The letter "S" is significantly larger and more stylized than the other letters. Below the word "Sears" is a horizontal line that tapers at both ends, resembling a swoosh or a stylized underline.