

# CRAFTSMAN®

## Tool Storage Roll-Away

THIS OPERATING INSTRUCTION MANUAL  
COVERS ALL THE PROFESSIONAL SERIES  
ROLL-AWAYS.

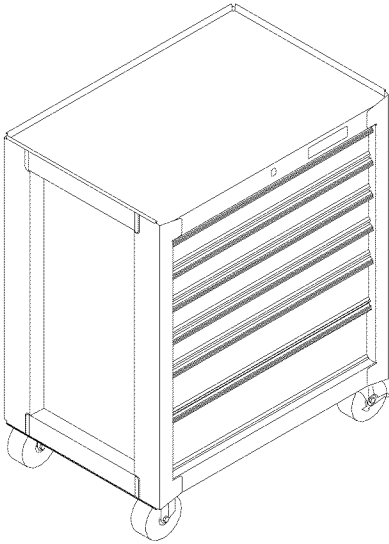

## PROFESSIONAL SERIES

Please indicate the following information  
from the service part drawing provided.

Model  
Number: \_\_\_\_\_

Model  
Description: \_\_\_\_\_

**CAUTION:** Read and follow all Safety  
Rules and Operating Instructions before  
first use of this product. Retain this  
document for future reference.

Sears, Roebuck and Co.  
Hoffman Estates, IL 60179 U.S.A.

F1374A1

## SAFETY RULES AND WARNINGS:

- **DO NOT** stand on this product. You may fall which may cause personal injury.
- **WEAR SAFETY GLASSES AND GLOVES** when cutting the banding material. The bands may snap which may cause personal injury.
- Stacked products should be bolted together. The products could become unstable and tip, which may cause personal injury or product damage.
- **WEAR SAFETY GLASSES** when removing or repositioning the slides. The tool could slip which may cause personal injury.
- When moving this product, do not pull it. Push the product to prevent personal injury.
- Handle and swivel casters must be attached on the same side of the product.
- **USE THE BRAKES** when not moving this product. This will prevent the product from rolling, which may cause personal injury or product damage.
- **BE CAREFUL** when opening more than one drawer. The product may become unstable and tip, which may cause personal injury or product damage.
- **DO NOT** mount this product on a truck bed or any other moving object. This may cause personal injury or product damage.
- **DO NOT** step in the drawers. You may fall which may cause personal injury.
- Appropriately secure this product before moving it with a forklift.
- **DO NOT** tow with power equipment. The product could tip, which may cause personal injury or product damage.
- **DO NOT** alter this product in any manner. For example, do not weld external lockbars or attach electrical equipment. This may cause product damage or personal injury.
- A heavy duty side cabinet must be used on an equally heavy duty roll-away.
- Keep the product on level surfaces. The product may become unstable and tip if stored or moved on an un-level surface, which may cause personal injury or product damage.
- Lock the drawers and doors before moving this product. The drawers or doors could come open and make the product unstable and tip, which may cause personal injury or product damage.
- The maximum weight for each drawer should be no more than 50 pounds.
- The maximum product weight, including contents, cannot exceed 1,180 pounds.

### DRAWER REMOVAL:

- Fully extend the drawer. Push it back a quarter of an inch.
- Insert a screwdriver into the slot in the slide and push in on the stop until it clears the lance. Repeat the procedure on the other slide and remove the drawer.
- To reinstall, pry the stop far enough out to engage the lance and push the drawer onto the slides until the stops pass over the lances.

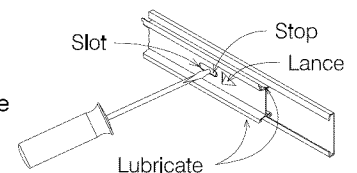

**LUBRICATION:** Lubricate the top and bottom channels  
of the drawer slides at least twice a year.

### HANDLE INSTALLATION: (dependant on model)

- Insert the handle tabs into the slots in the end of the roll-away.
- Attach the handle using four 1/4-20 x 3/8 slotted round head screws.
- Insert one plug in each end of the side handle.

### LOCKING THE UNIT:

If the unit has no panel, the lock activates the locking mechanism.

- To unlock, turn the key to the right and the unit is unlocked.
- To lock, make sure all drawers are fully closed, turn the key, then remove the key.

If the unit has a panel, the panel activates the locking mechanism.

- To unlock the unit, turn the key to the right and the panel automatically springs open at the bottom. Pull out, lift up and push the panel back into the unit.
- To lock, pull panel straight out, then lower, press lightly at the bottom and turn the key

### CASTER INSTALLATION:

- Lay the roll-away on its back. Use packaging material to protect the finish.
- Mount both swivel casters on the same side of the unit as the side handle.
- Attach the casters using four 14-10 x 5/8 screws on each caster.
- Wrench tighten all screws. It is recommended not to exceed 80 inch pounds of torque.
- Return the unit to its upright position.

Call 1-800-366-7278 for  
Service Parts



Refer to Service Parts Drawing for full  
listing of Service Parts

# CRAFTSMAN®

## Caja deslizable para herramientas

ESTE MANUAL DE INSTRUCCIONES DE OPERACION CUBRE TODAS LAS SERIE PROFESIONAL

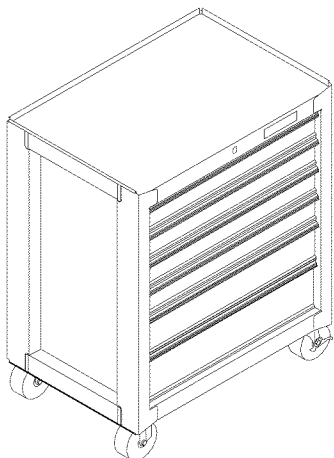

## SERIE PROFESIONAL

Sírvase indicar la siguiente información que encontrará en el dibujo suministrado de la pieza de servicio.

Número de modelo: \_\_\_\_\_

Descripción del modelo: \_\_\_\_\_

**CUIDADO:** Antes de utilizar este producto por primera vez, lea y observe todos los reglamentos de seguridad y las instrucciones de operación. Guarde este documento para referencia futura.

Sears Roebuck and Co.  
Hoffman Estates, IL 60179, EE.UU.

F1374A1

Para solicitar piezas de repuesto, llame al  
1-800-659-7084



Consulte el Dibujo de las piezas de servicio para obtener una lista completa de las piezas de servicio.

## REGLAMENTOS DE SEGURIDAD Y ADVERTENCIAS:

- **NO** se pare sobre este producto. Se puede caer y lesionarse.
- **USE GAFAS Y GUANTES DE SEGURIDAD** al cortar los zunchos. Estos pueden romperse bruscamente y ocasionar lesiones personales.
- Los productos apilados se deben atornillar entre sí. Podrían quedar inestables y volcarse, lo cual podría causar lesiones personales o daños al producto.
- **USE GAFAS DE SEGURIDAD** al quitar o volver a colocar las correderas. Se podría resbalar la herramienta y causar lesiones personales.
- Al mover el producto, no tire del mismo. Empújelo, de esta manera evitará lesiones personales.
- La manija y las ruedecillas giratorias deben instalarse en el mismo lado del producto.
- **USE LOS FRENOS** cuando no esté moviendo este producto. Esto impedirá que ruede, lo cual podría causar lesiones personales o daños al producto.
- **TENGA MUCHO CUIDADO** al abrir varias gavetas. El producto podría quedar inestable y volcarse, lo cual podría causar lesiones personales o daños al producto.
- **NO** instale este producto sobre la plataforma de un camión ni sobre ningún otro objeto móvil. Esto podría causar lesiones personales o daños al producto.
- **NO** se pare en las gavetas. Se puede caer y lesionarse.
- Antes de mover este producto con un montacargas, asegúrelo de manera adecuada.
- **NO** remolque el producto con un equipo motorizado. Se puede volcar y causar lesiones personales o daños al producto.
- **NO** modifique este producto de ninguna forma. Por ejemplo, no suelde barras de bloqueo ni fije equipos eléctricos. Esto podría causar daños al producto o lesiones personales.
- Un gabinete lateral extrafuerte se debe usar en una caja deslizable que también sea extrafuerte.
- Mantenga el producto sobre superficies niveladas. Si se guarda sobre una superficie desnivelada, o se mueve a ella, el producto podría quedar inestable y volcarse, lo cual podría causar lesiones personales o daños al producto.
- Asegure las gavetas y puertas antes de mover este producto. Estas se podrían abrir y hacer que el producto quede inestable y se vuelque, lo cual podría causar lesiones personales o daños al producto.
- El peso máximo en cada gaveta no debe ser mayor de 50 libras.
- El peso máximo del producto, incluyendo su contenido, no puede ser mayor de 1,180 libras.

## RETIRO DE LA GAVETA:

- Abra por completo la gaveta. Hágala retroceder 6 mm.
- Introduzca un destornillador dentro de la abertura en la corredera y empuje el tope hasta que sobrepase la lanceta. Repita el procedimiento en la otra corredera y quite la gaveta.
- Para volver a instalar la gaveta, fuerce el tope lo suficiente para enganchar la lanceta y empuje la gaveta dentro de las correderas hasta que los topes sobrepasen las lancetas.

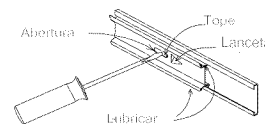

**LUBRICACION:** Lubrique los canales superior e inferior de las correderas de la gaveta cuando menos dos veces al año.

## INSTALACION DE LA MANIJA: (según del modelo)

- Introduzca las pestañas de la manija en las aberturas en el extremo de la caja deslizable.
- Asegure la manija usando cuatro tornillos de cabeza redonda ranurada de 1/4-20 x 3/8.
- Inserte un tapón en cada extremo de la manija lateral.

## PONER SEGURO A LA UNIDAD:

Si la unidad no tiene ningún panel, el seguro activa el mecanismo de cierre.

- Para quitar el seguro a la unidad, gire la llave hacia la derecha y quedará sin seguro.
- Para poner seguro a la unidad, cerciórese de que todas las gavetas estén bien cerradas, gire la llave y quítela.

Si la unidad tiene un panel, éste activa el mecanismo de cierre.

- Para quitar el seguro a la unidad, gire la llave hacia la derecha y el panel se abre automáticamente en la parte inferior. Tire del panel hacia afuera, levántelo y empújelo de nuevo dentro de la unidad.
- Para poner seguro a la unidad, tire del panel derecho hacia afuera, bájelo, presione ligeramente en la parte inferior y gire la llave.

## INSTALACION DE LAS RUEDECILLAS:

- Acueste la caja deslizable sobre su parte trasera. Proteja el acabado con material de embalaje.
- Instale las dos ruedecillas giratorias en el mismo lado de la unidad que la manija lateral.
- Asegure las ruedecillas usando cuatro tornillos de 14-10 x 5/8 en cada una.
- Apriete todos los tornillos con una llave. Se recomienda no torsionar a más de 80 pulg.-lbs.
- Vuelva a colocar la unidad en su posición vertical.

## Socket Organizers

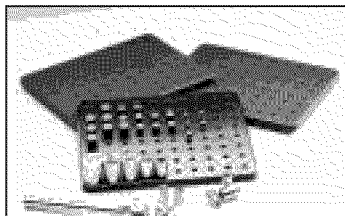

**65287 103-Pc. Socket Organizer (R/C)**

- Three plastic socket trays, 6.5" x 8"
- Also includes twenty-five 1/4-in., fifty 3/8-in., and twenty-five 1/2-in. drive socket pins

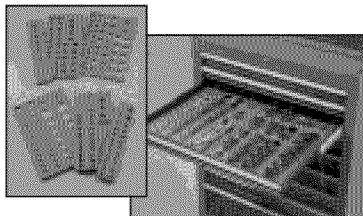

**65172 Socket Organizer (Grey) (R)**  
**65165 Socket Organizer (Red) (C)**

- Six-tray set consists of SAE and Metric 1/4-in., 3/8-in., and 1/2-in. drive trays
- Organizes up to 195 shallow or deep well sockets and provides a visual inventory to identify missing sockets

## Drawer Dividers

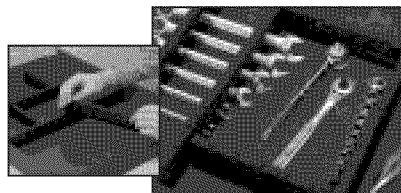

**65397 Universal Divider System (R)**

- Divides drawers for organization
- Slotted top design may also be used to hold wrenches in place
- Strips may be cut to desired lengths to customize drawer organization

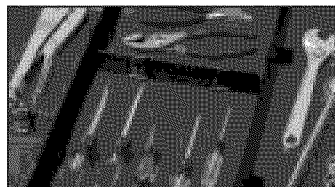

**65278 Plastic Divider System (R)**

- Includes sixteen "T" connectors, four 16 1/4-in. "L"-shape dividers, and adhesive tape
- Organizes up to four drawers without cutting for easy installation

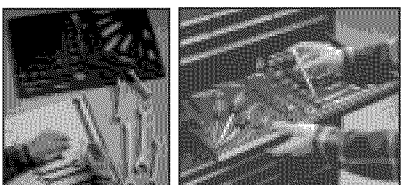

**65417 Foam Drawer Organizer (R)**

- Foam inserts organize three chest drawers or two roll-away drawers
- Includes two foam inserts 16.75" x 22.38" x 0.5" thick, a retractable knife, two adhesive layout sheets, and instructions



**65296 Chest Drawer Tray Organizer (R)**

- 11 pockets in a variety of sizes for storage of small items
- Fits all 22.5"W x 10.75"D x 2"H Craftsman chest drawers



**65297 Roll-Away Tray Organizer Set (R)**

- 3 trays with small, medium, and large pockets
- Fits all 22.5"W x 16.75"D x 3"H Craftsman chest and roll-away drawers

## Drawer Liners

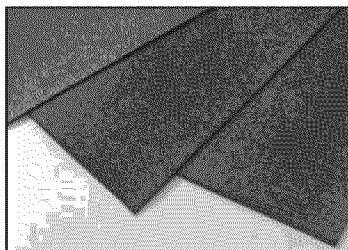

### Foam Drawer Liners

**65215 6-Pc. Chest (R)**  
**65216 5-Pc. Roll-Away (R)**  
**65217 4-Pc. Portable Chest (R)**  
**65502 85.5-in. Length Roll (R)**

- Foam drawer liners cushion drawer bottom from scratches
- Resists thinners, battery acid, gasoline, oil, and cleaning solvents

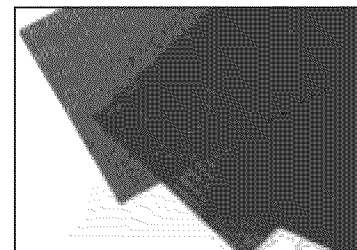

### Mesh Non-Slip Drawer Liners

**65498 6-Pc. Chest (R)**  
**65499 5-Pc. Roll-Away (R)**

- Prevents tools from sliding around in drawer
- Non-skid open weave design pulls moisture away from tools reducing corrosion
- Resists thinners, battery acid, gasoline, oil, and cleaning solvents

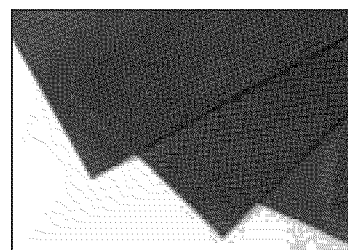

### Open Weave Non-Slip Drawer Liners

**65522 6-Pc. Chest (R/C)**  
**65524 5-Pc. Roll-Away (R/C)**  
**65514 85.5-in. Length Roll (R/C)**

- Prevents tools from sliding around in drawers
- Thick, non-skid open weave design pulls moisture away from tools reducing corrosion
- Resists household chemicals and fuels

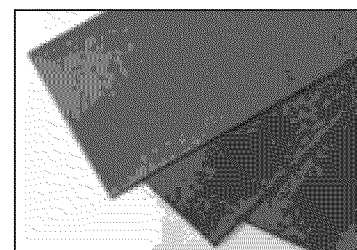

### Foam Laminate Non-Slip Drawer Liners

**65532 6-Pc. Chest (R)**  
**65534 5-Pc. Roll-Away (R)**

- Black, thick foam laminate, non-slip/tear resistant material
- Prevents tools from sliding around in drawers
- Resists thinners, battery acid, gasoline, oil, and cleaning solvents

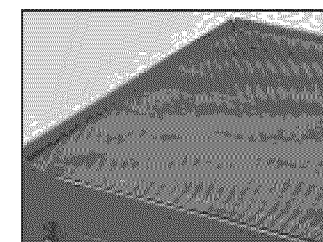

### Top Mats

**65652 26 1/4"W x 17 3/4"D (R)**  
**65660 26 1/4"W x 17 3/4"D (Diamond Embossed Pattern) (R)**

- Ideal when using the top of a roll-away as a work table
- Oil and grease resistant
- Prevents tools from sliding
- Protects roll-away tops from scratches

## Additional Accessories

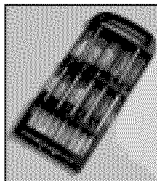

**65273 Screwdriver Organizer (R)**

- Holds up to 13 Craftsman Screwdrivers
- Designated area for offset and micro screwdrivers



**65272 Wrench Organizer (R)**

- Holds up to 12 wrenches
- Fits inside 3-in. high drawer or mounts to wall

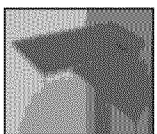

**65213 Folding Metal Side Shelf (R/C)**

- Holds up to 70 lbs. and includes braces
- Measures 18" x 15" x 14"

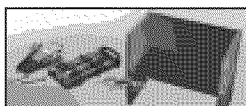

**65970 3-Piece Accessory Kit (R)**

- Wrench organizer holds up to 12 wrenches
- Screwdriver organizer holds up to 13 screwdrivers
- Riser measures 22" x 12" x 9 1/2"

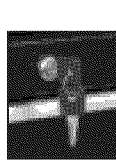

### Lock Sets (R)

**65573 Lock Set for Craftsman Homeowner Chest, Intermediate Chest, and Roll-Away**  
**65584 Lock Set for Craftsman Premium or Ball-Bearing Chest, Intermediate Chest, and Roll-Away**  
**65587 Lock Set for Craftsman 40-in. Wide Chest, Mobile Tool Cart, and Security Drawer**

- Three overmolded reversible keys included
- Allows you to key all your tool storage units to the same lock.

**65276 5 x 2-in. Caster Set (R/C)**  
**65207 6 x 2-in. Caster Set (C)**



**65198 Decal Set (R)**

- Set of four casters, two swivel with toe brake and two rigid
- Use with Craftsman roll-aways and mobile tool carts

- Five decal strips, including Craftsman logos and racing decals

## Intermediate Chests

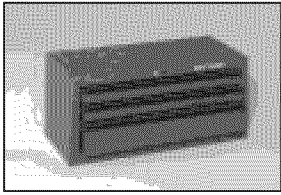

**59883 12" Deep, 3-Drawer Intermediate, Red (R/C)**

- All drawers measure 22.125"W x 10.75"D; two are 2"H and one is 4"H
- Fits between all Homeowner-Quality chests and roll-aways for an additional 1,877 cu. in. of storage space

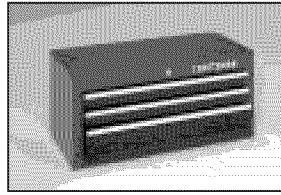

**65120 12" Deep, 3-Drawer Intermediate, Red (R)**

- 3 drawers measure 22.375"W x 10.75"D; two are 2"H and one is 4.125"H
- Fits between all Craftsman 12" deep chests and roll-aways
- Red baked enamel shell with charcoal baked enamel drawers

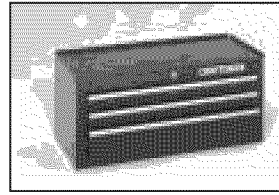

**65130 12" Deep, 3-Drawer Intermediate, Black (R)**

- 3 drawers measure 22.375"W x 10.75"D; two are 2"H and one is 4.125"H
- Fits between all Craftsman 12" deep chests and roll-aways
- Black baked enamel shell and drawers

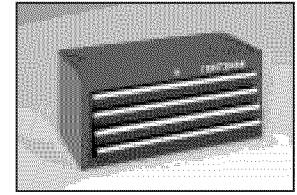

**65029 12" Deep, 4-Drawer Intermediate, Red (R/C)**

- 4 drawers measure 22.375"W x 10.75"D x 2"H
- Fits between all Craftsman 12" deep chests and roll-aways
- Red baked enamel shell with charcoal baked enamel drawers
- Also available: Blue 59925  
Black 65950

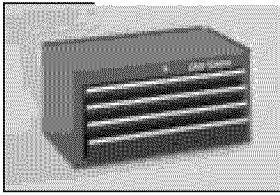

**65144 16" Deep, 4-Drawer Intermediate, Red (R/C)**

- 4 drawers measure 22.375"W x 14.5"D; three are 2"H and one is 3.125"H
- Fits between all 12" and 16" deep Craftsman chests and roll-aways
- Red baked enamel shell with charcoal baked enamel drawers

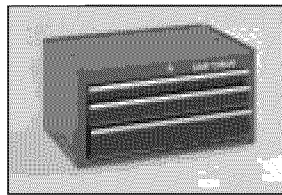

**65030 18" Deep, 3-Drawer Intermediate, Red (R/C)**

- 3 drawers measure 22.375"W x 16.375"D; one is 2"H, one is 3.125"H, and one is 4.125"H
- Fits between all Craftsman chests and roll-aways
- Red baked enamel shell with charcoal baked enamel drawers

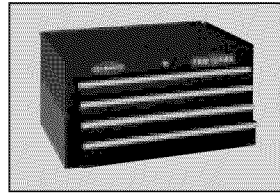

**59601 16" Deep, 4-Drawer Ball-Bearing Intermediate, Black (R/C)**

- Fits Craftsman 12" and 16" deep chests and all Craftsman roll-aways
- GRIPLATCH™ ball-bearing action drawer slides provide smooth operation under heavy loads
- Also available: Red 59701  
Blue 59895

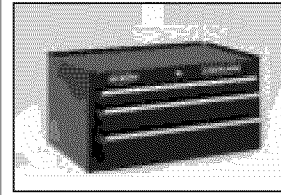

**59603 18" Deep, 3-Drawer Ball-Bearing Intermediate, Black (R/C)**

- Fits between all Craftsman Ball-Bearing and Premiumchests and roll-aways
- GRIPLATCH™ ball-bearing action drawer slides provide smooth operation under heavy loads
- Also available: Red 59703

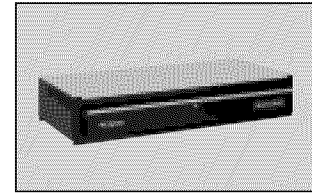

**59604 40" Wide, 1-Drawer Ball-Bearing Intermediate, Black (R/C)**

- Fits between all Craftsman 40" wide chests and mobile tool carts
- GRIPLATCH™ ball-bearing action drawer slides provide smooth operation under heavy loads
- Also available: Red 59704

## Side Cabinets and Lockers

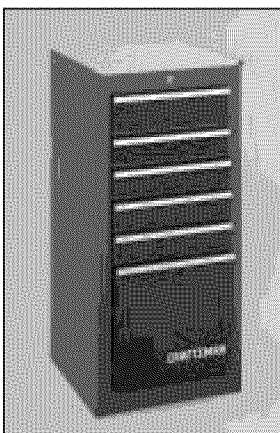

**65022 6-Drawer Side Cabinet Red (R/C)**

- All drawers are 11.75"W x 16.5"D; four are 3.125"H, one is 4.125"H, and one is 12.75"H
- Can be mounted on either side of any Craftsman roll-away at least 41.25" high
- Internal locking system with two reversible overmolded keys
- Also available: Black 59931

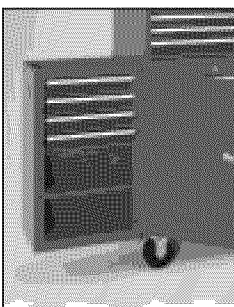

**65027 4-Drawer Side Cabinet, Red (C)**

- All drawers are 13.75"W x 9.5"D x 2.75"H
- Door with lock and two reversible overmolded keys
- Can be mounted to either side of any Craftsman roll-away

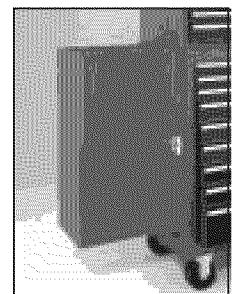

**65763 Bulk Storage Cabinet, Red (R/C)**

- Two adjustable shelves
- T-handle has tumbler lock with two reversible overmolded keys
- Can be mounted to either side of any Craftsman roll-away
- Can also be mounted to a wall as a wall cabinet

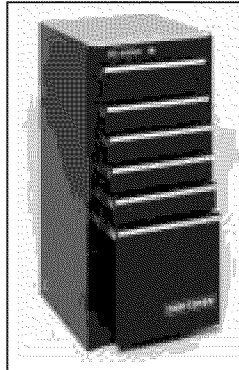

**59602 6-Drawer Ball-Bearing Side Cabinet, Black (R/C)**

- Can be mounted on either side of any Craftsman roll-away that measures at least 41.25" high
- GRIPLATCH™ ball-bearing slides
- Thick and durable work-surface lets you work right next to your tools
- Also available: Red 59702

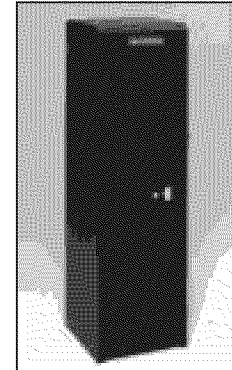

**59605 4-Drawer, Full Height, Ball-Bearing Side Locker, Black (R/C)**

- Can be mounted on either side of any 40" wide Craftsman chest and tool cart combination (tool cart must be at least 41.25" high)
- Also available: Red 59705

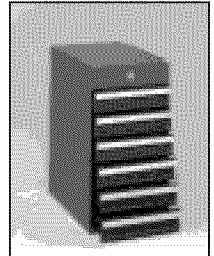

**65142 6-Drawer Tool Caddy, Red (R/C)**

- All drawers are 6.710"W x 10.75"D x 2"H
- Internal lock system with two reversible overmolded keys
- Can be mounted on either side of any Craftsman roll-away