

SEARS

OWNER'S MANUAL

MODEL NO. 917.25009

**Important:
Read and follow
all Safety Rules
and Instructions
Before Operating
This Equipment**

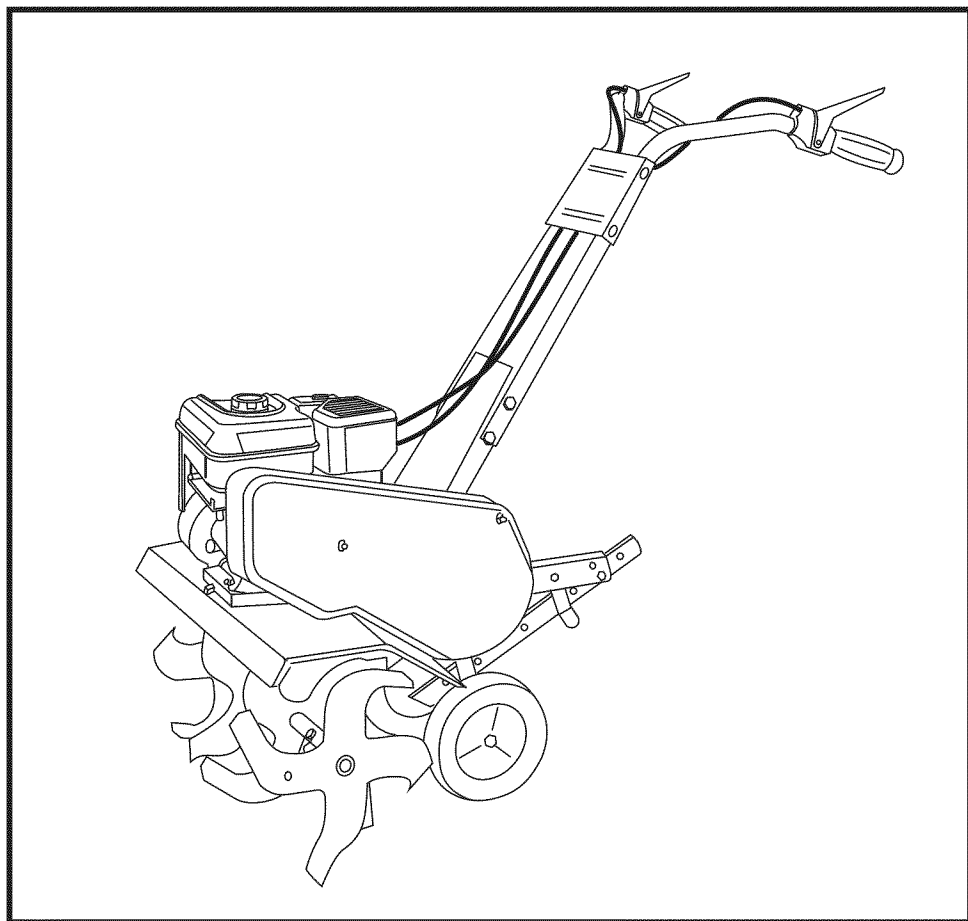

CRAFTSMAN®

900 SERIES 24" TINE WIDTH

- **Assembly**
- **Operation**
- **Maintenance**
- **Service and Adjustments**
- **Repair Parts**

**Gasoline containing up to 10% ethanol (E10) is acceptable for use in this machine.
The use of any gasoline exceeding 10% ethanol (E10) will void the product warranty.**

Sears Canada, Inc., Toronto, Ontario M5B 2B8



SAFETY RULES



SAFE OPERATION PRACTICES FOR WALK-BEHIND POWERED ROTARY TILLERS

TRAINING

- Read the Owner's Manual carefully. Be thoroughly familiar with the controls and the proper use of the equipment. Know how to stop the unit and disengage the controls quickly.
- Never allow children to operate the equipment. Never allow adults to operate the equipment without proper instruction.
- Keep the area of operation clear of all persons, particularly small children, and pets.

PREPARATION

- Thoroughly inspect the area where the equipment is to be used and remove all foreign objects.
- Disengage all clutches and shift into neutral before starting the engine (motor).
- Do not operate the equipment without wearing adequate outer garments. Wear footwear that will improve footing on slippery surfaces.
- Handle fuel with care; it is highly flammable.
- Use an approved fuel container.
- Never add fuel to a running engine or hot engine.
- Fill fuel tank outdoors with extreme care. Never fill fuel tank indoors.
- Replace gasoline cap securely and clean up spilled fuel before restarting.
- Use extension cords and receptacles as specified by the manufacturer for all units with electric drive motors or electric starting motors.
- Never attempt to make any adjustments while the engine (motor) is running (except where specifically recommended by manufacturer).

OPERATION

- Do not put hands or feet near or under rotating parts.
- Exercise extreme caution when operating on or crossing gravel drives, walks, or roads. Stay alert for hidden hazards or traffic. Do not carry passengers.
- After striking a foreign object, stop the engine (motor), remove the wire from the spark plug, thoroughly inspect the tiller for any damage, and repair the damage before restarting and operating the tiller.
- Exercise caution to avoid slipping or falling.
- If the unit should start to vibrate abnormally, stop the engine (motor) and check immediately for the cause. Vibration is generally a warning of trouble.
- Stop the engine (motor) when leaving the operating position.
- Take all possible precautions when leaving the machine unattended. Disengage the tines, shift into neutral, and stop the engine.
- Before cleaning, repairing, or inspecting, shut off the engine and make certain all moving parts have stopped. Disconnect the spark plug wire, and keep the wire away from the plug to prevent accidental starting. Disconnect the cord on electric motors.
- Do not run the engine indoors; exhaust fumes are dangerous.

- Never operate the tiller without proper guards, plates, or other safety protective devices in place.
- Keep children and pets away.
- Do not overload the machine capacity by attempting to till too deep at too fast a rate.
- Never operate the machine at high speeds on slippery surfaces. Look behind and use care when backing.
- Never allow bystanders near the unit.
- Use only attachments and accessories approved by the manufacturer of the tiller.
- Never operate the tiller without good visibility or light.
- Be careful when tilling in hard ground. The tines may catch in the ground and propel the tiller forward. If this occurs, let go of the handlebars and do not restrain the machine.

MAINTENANCE AND STORAGE

- Keep machine, attachments, and accessories in safe working condition.
- Check shear pins, engine mounting bolts, and other bolts at frequent intervals for proper tightness to be sure the equipment is in safe working condition.
- Never store the machine with fuel in the fuel tank inside a building where ignition sources are present, such as hot water and space heaters, clothes dryers, and the like. Allow the engine to cool before storing in any enclosure.
- Always refer to the operator's guide instructions for important details if the tiller is to be stored for an extended period.

- IMPORTANT -

CAUTIONS, IMPORTANTS, AND NOTES ARE A MEANS OF ATTRACTING ATTENTION TO IMPORTANT OR CRITICAL INFORMATION IN THIS MANUAL.

IMPORTANT: USED TO ALERT YOU THAT THERE IS A POSSIBILITY OF DAMAGING THIS EQUIPMENT.

NOTE: Gives essential information that will aid you to better understand, incorporate, or execute a particular set of instructions.



Look for this symbol to point out important safety precautions. It means CAUTION!!! BECOME ALERT!!! YOUR SAFETY IS INVOLVED.



CAUTION: Always disconnect spark plug wire and place wire where it cannot contact spark plug in order to prevent accidental starting when setting up, transporting, adjusting or making repairs.



WARNING



The engine exhaust from this product contains chemicals known to the State of California to cause cancer, birth defects, or other reproductive harm.

PRODUCT SPECIFICATIONS

Gasoline Capacity: Unleaded Regular	2.9 Quarts (2.7L)
Oil (API:SG-SL): (Capacity: 20 oz./0.6L)	SAE 30 (Above 32°F/0°C) SAE 5W30 (Below 32°F/0°C)
Spark Plug :	Champion RC12YC (Gap: .030"/0.76mm)

CONGRATULATIONS on your purchase of a new tiller. It has been designed, engineered and manufactured to give you the best possible dependability and performance.

Should you experience any problems you cannot easily remedy, please contact your nearest authorized service center. We have competent, well-trained technicians and the proper tools to service or repair this unit.

Please read and retain this manual. The instructions will enable you to assemble and maintain your tiller properly. Always observe the "SAFETY RULES".

CUSTOMER RESPONSIBILITIES

- Read and observe the safety rules.
- Follow a regular schedule in maintaining, caring for and using your tiller.
- Follow instructions under "Maintenance" and "Storage" sections of this Manual.

IMPORTANT: THIS UNIT IS EQUIPPED WITH AN INTERNAL COMBUSTION ENGINE AND SHOULD NOT BE USED ON OR NEAR ANY UNIMPROVED FOREST-COVERED, BRUSH-COVERED OR GRASS COVERED LAND UNLESS THE ENGINE'S EXHAUST SYSTEM IS EQUIPPED WITH A SPARK ARRESTER MEETING APPLICABLE LOCAL LAWS (IF ANY). IF A SPARK ARRESTER IS USED, IT SHOULD BE MAINTAINED IN EFFECTIVE WORKING ORDER BY THE OPERATOR.

IN THE STATE OF CALIFORNIA, A SPARK ARRESTER IS REQUIRED BY LAW (SECTION 4442 OF THE CALIFORNIA PUBLIC RESOURCES CODE). OTHER STATES MAY HAVE SIMILAR LAWS. FEDERAL LAWS APPLY ON FEDERAL LANDS. SEE YOUR AUTHORIZED SERVICE CENTER/DEPARTMENT FOR SPARK ARRESTER.

TABLE OF CONTENTS

SAFETY RULES	2
CUSTOMER RESPONSIBILITIES.....	3
PRODUCT SPECIFICATIONS.....	3
ASSEMBLY	4-5
OPERATION	6-9
MAINTENANCE SCHEDULE	10

MAINTENANCE	10-12
SERVICE & ADJUSTMENTS	13-15
STORAGE.....	16
TROUBLESHOOTING	17
REPAIR PARTS	18-23
WARRANTY.....	24-27

ASSEMBLY

Your new tiller has been assembled at the factory with exception of those parts left unassembled for shipping purposes. To ensure safe and proper operation of your tiller all parts and hardware you assemble must be tightened securely. Use the correct tools as necessary to insure proper tightness.

TOOLS REQUIRED FOR ASSEMBLY

A socket wrench set will make assembly easier. Standard wrench sizes are listed.

- (1) Utility knife
- (1) Screwdriver
- (1) Pair of pliers
- (2) 1/2" wrenches

OPERATOR'S POSITION (See Fig. 1)

When right or left hand is mentioned in this manual, it means when you are in the operating position (standing behind tiller handles).

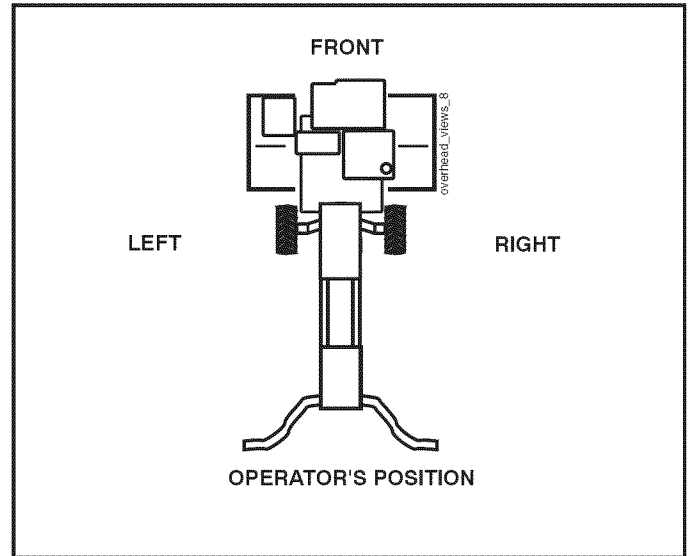
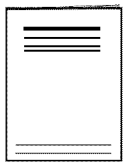
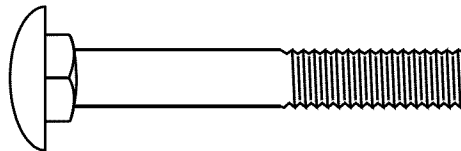

Fig. 1

CONTENTS OF HARDWARE PACK



(1) Manual



(2) Carriage Bolts 5/16-18 UNC x 2-1/2

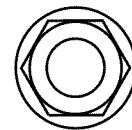

(2) Flange Locknuts
5/16-18 UNC

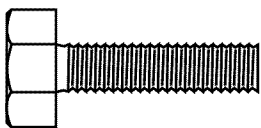

(2) Hex Bolts 5/16-18 x 1-1/4



(1) Bottle Engine Oil

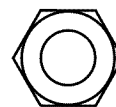

(2) Hex Nuts 5/16-18

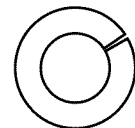

(2) Lock Washers 5/16

ASSEMBLY

UNPACK CARTON & INSTALL HANDLE (See Fig. 2)



CAUTION: Be careful of exposed staples when handling or disposing of cartoning material.

IMPORTANT: WHEN UNPACKING AND ASSEMBLING TILLER, BE CAREFUL NOT TO STRETCH OR KINK CABLE(S).

- Cut cable ties securing handles.
- Slowly lift handle assembly up, route cable(s) as shown and align handle holes with handle panel hole and slot.
- Loosely assemble hardware as shown. Be sure the shorter (1" long) hex bolt is assembled in lower hole of handle. Repeat for opposite side. Tighten all hardware securely.
- Cut cable ties securing tiller to skid and remove tiller from skid.
- Remove screws securing depth stake to skid and discard the screws.
- Remove plastic film from engine.

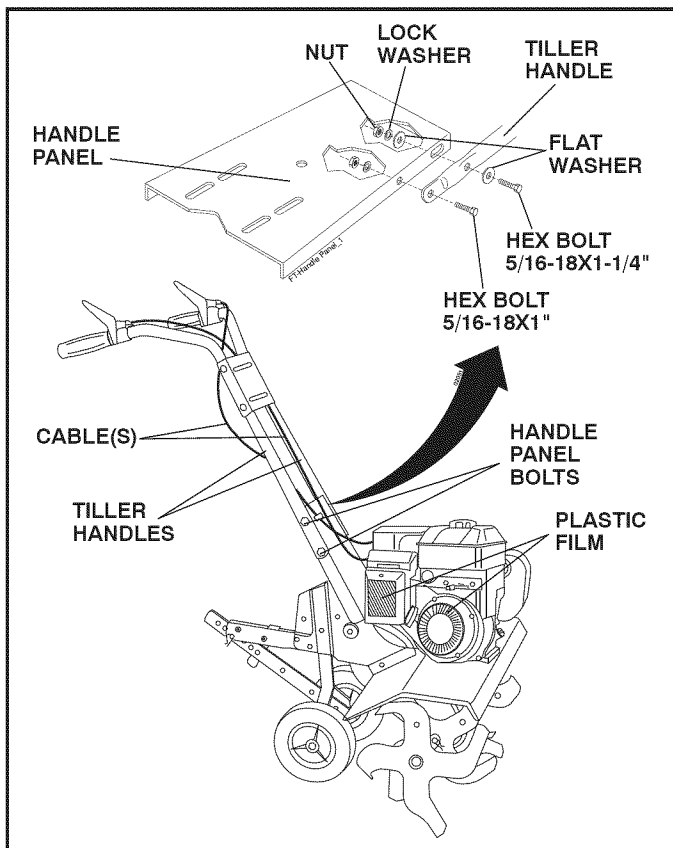

Fig. 2

INSTALL DEPTH STAKE ASSEMBLY (See Fig. 3)

- Loosen nut "A".
- Insert stake support between engine bracket halves with stake spring down.
- Bolt stake support to engine brackets with bolts, lock washers and nuts. Tighten securely. Tighten nut "A".
- Depth stake must move freely. If it does not, loosen support bolt.

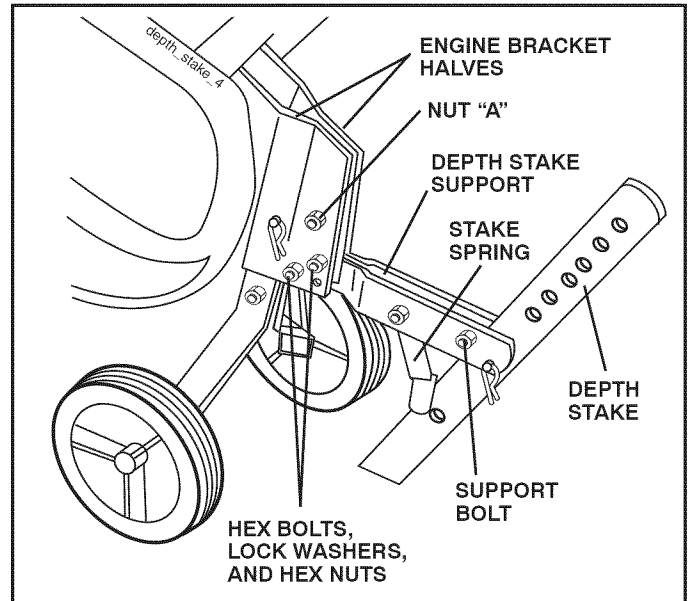

Fig. 3

HANDLE HEIGHT

- Handle height may be adjusted to better suit operator. (See "HANDLE HEIGHT" in the Service and Adjustments section of this manual).

TILLING WIDTH

- Tilling width may be adjusted to better handle your tilling conditions (See "TINE ARRANGEMENT" in the Service and Adjustments section of this manual).

TINE OPERATION

- Check tine operation before first use. (See "TINE OPERATION CHECK" in the Service and Adjustments section of this manual).

OPERATION

KNOW YOUR TILLER

READ THIS MANUAL AND SAFETY RULES BEFORE OPERATING YOUR TILLER.

Compare the illustrations with your tiller to familiarize yourself with the location of various controls and adjustments. Save this manual for future reference.

These symbols may appear on your Tiller or in literature supplied with the product. Learn and understand their meaning.

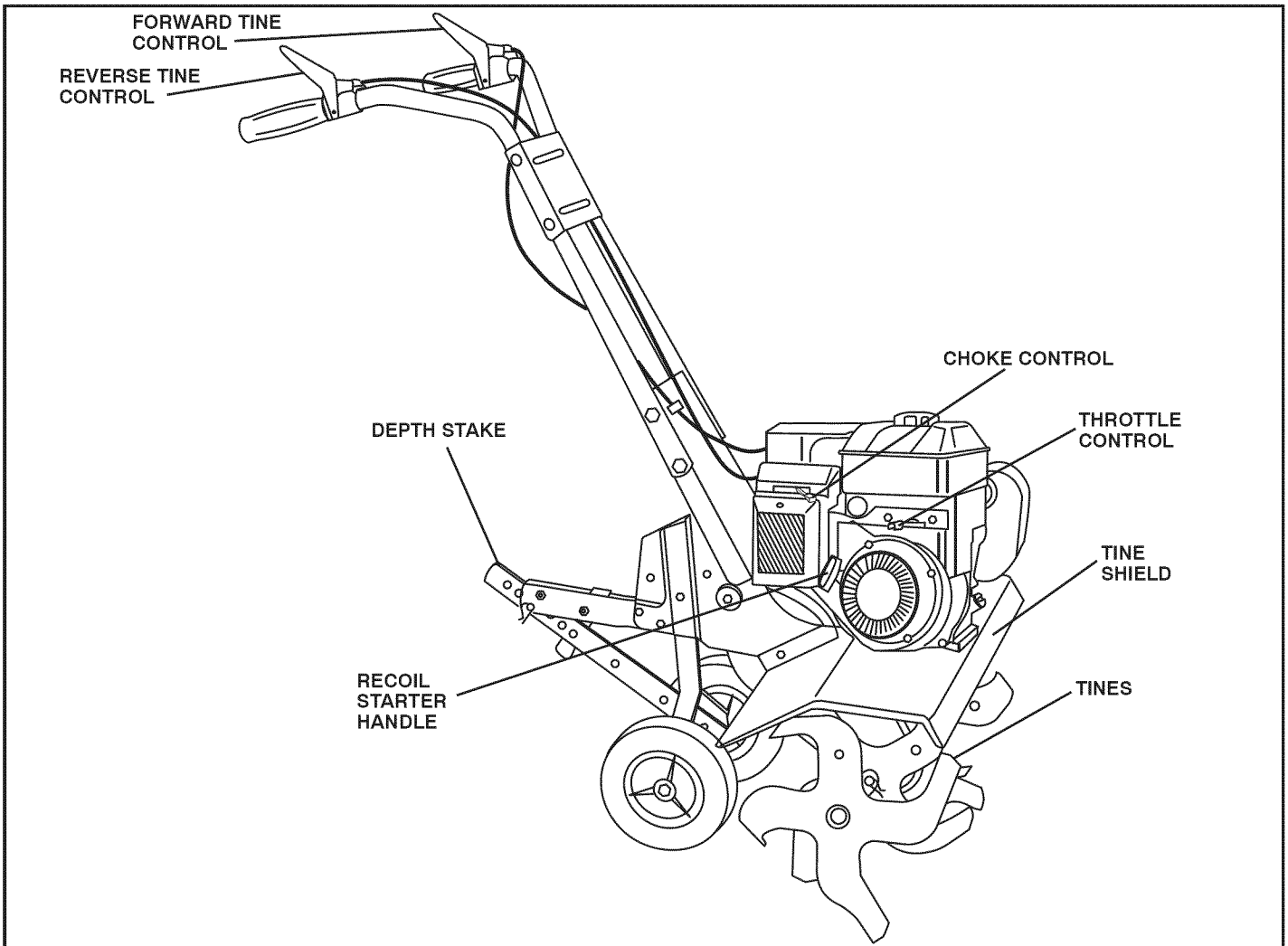
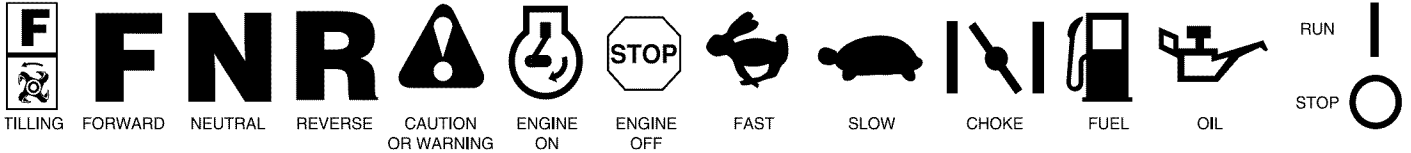

Fig. 4

MEETS ANSI SAFETY REQUIREMENTS

Our tillers conform to the safety standards of the American National Standards Institute.

CHOKE CONTROL - Used when starting a cold engine.

DEPTH STAKE - Controls forward speed and the depth at which the tiller will dig.

FORWARD TINE CONTROL - Engages tines in forward direction.

REVERSE TINE CONTROL - Engages tines in reverse direction.
RECOIL STARTER HANDLE - Used to start the engine.

THROTTLE CONTROL - Controls engine speed.

OPERATION



The operation of any tiller can result in foreign objects thrown into the eyes, which can result in severe eye damage. Always wear safety glasses or eye shields before starting your tiller and while tilling. We recommend a wide vision safety mask over spectacles or standard safety glasses.

HOW TO USE YOUR TILLER

Know how to operate all controls before adding fuel and oil or attempting to start engine.

STOPPING (See Fig. 5)

TINES

- Release forward tine control to stop forward movement.
- Release reverse tine control to stop reverse movement.

ENGINE

- Move throttle control to "STOP" position.
- Never use choke to stop engine.

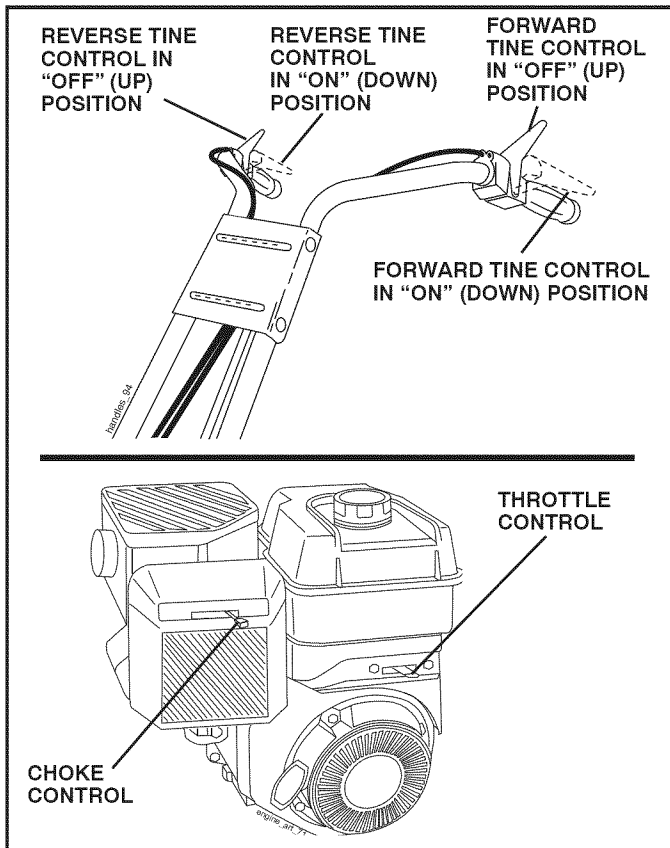

Fig. 5

TINE OPERATION (See Fig. 5)

FORWARD

- With reverse tine control in the "OFF" (up) position, Squeeze forward tine control to handle.

REVERSE

- With forward tine control in the "OFF" (up) position, Squeeze reverse tine control to handle.

TILLING

The speed and depth of tilling is regulated by the position of the depth stake and wheel height.

The depth stake should always be below the wheels for digging. It serves as a brake to slow the tiller's forward motion to enable the tines to penetrate the ground. Also, the more the depth stake is lowered into the ground the deeper the tines will dig.

DEPTH STAKE (See Fig. 6)

Adjust depth stake by removing the hairpin clip and clevis pin. Change depth stake to desired position. Replace the clevis pin and hairpin clip.

- For normal tilling, set depth stake at the second or third hole from the top.

WHEELS (See Fig. 6)

Adjust wheels by removing the hairpin clip and clevis pin. Change wheel position. Replace the hairpin clip and clevis pin.

- For normal tilling, set wheels at the second or third hole from the top.

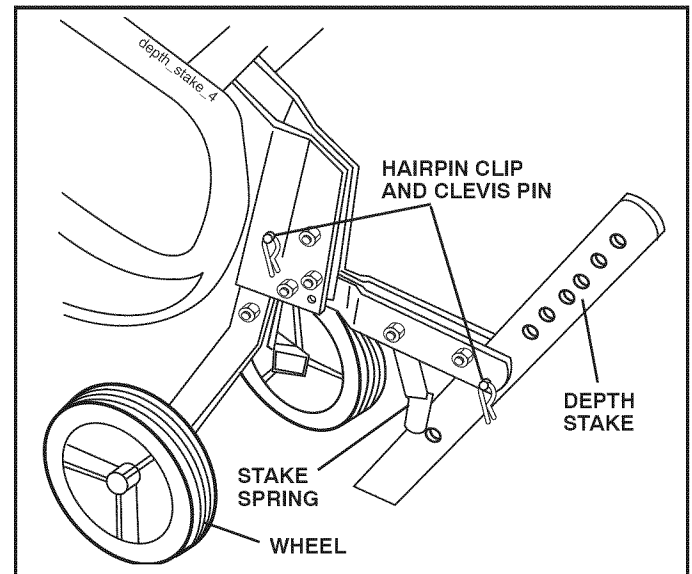

Fig. 6

OPERATION

TO TRANSPORT



CAUTION: Before lifting or transporting, allow tiller engine and muffler to cool. Disconnect spark plug wire. Drain gasoline from fuel tank.

AROUND THE YARD

- Tip depth stake forward until it is held by the stake spring.
- Push tiller handles down, raising tines off the ground.
- Push or pull tiller to desired location.

AROUND TOWN

- Disconnect spark plug wire.
- Drain fuel tank.
- Transport in upright position to prevent oil leakage.

BEFORE STARTING ENGINE

IMPORTANT: BE VERY CAREFUL NOT TO ALLOW DIRT TO ENTER THE ENGINE WHEN CHECKING OR ADDING OIL OR FUEL. USE CLEAN OIL AND FUEL AND STORE IN APPROVED, CLEAN, COVERED CONTAINERS. USE CLEAN FILL FUNNELS.

FILL ENGINE WITH OIL (See Fig. 7)

- With engine level, remove engine oil filler plug.
- Fill engine with oil to point of overflowing. For approximate capacity see "PRODUCT SPECIFICATIONS" on page 3 of this manual.
- Tilt tiller back on its wheels and then re-level.
- With engine level, refill to point of overflowing if necessary. Replace oil filler plug.
- For cold weather operation you should change oil for easier starting (See "OIL VISCOSITY CHART" in the Maintenance section of this manual).
- To change engine oil, see the Maintenance section of this manual.

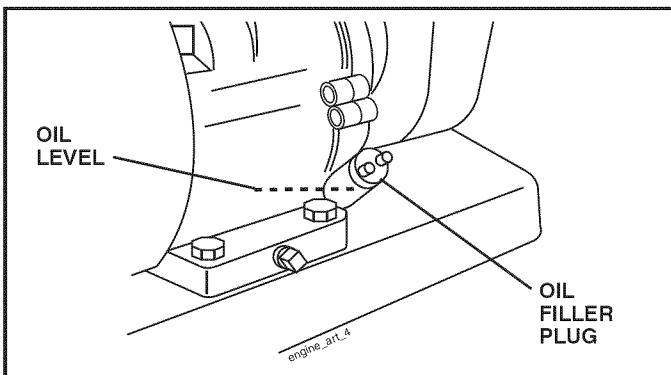

Fig. 7

ADD GASOLINE

- Fill to within 1/2 inch of top of fuel tank to prevent spills and to allow for fuel expansion. Do not overfill. Use fresh, clean, regular unleaded gasoline with a minimum of 87 octane. (Use of leaded gasoline will increase carbon and lead oxide deposits and reduce valve life). Do not mix oil with gasoline. Purchase fuel in quantities that can be used within 30 days to assure fuel freshness.



CAUTION: Fill to within 1/2" of top of fuel tank to prevent spills and to allow for fuel expansion. If gasoline is accidentally spilled, move machine away from area of spill. Avoid creating any source of ignition until gasoline vapors have disappeared.

Wipe off any spilled oil or fuel. Do not store, spill or use gasoline near an open flame.

IMPORTANT: WHEN OPERATING IN TEMPERATURES BELOW 32°F(0°C), USE FRESH, CLEAN WINTER GRADE GASOLINE TO HELP INSURE GOOD COLD WEATHER STARTING.

CAUTION: Alcohol blended fuels (called gasohol or using ethanol or methanol) can attract moisture which leads to separation and formation of acids during storage. Acidic gas can damage the fuel system of an engine while in storage. To avoid engine problems, the fuel system should be emptied before storage of 30 days or longer. Drain the gas tank, start the engine and let it run until the fuel lines and carburetor are empty. Use fresh fuel next season. See Storage Instructions for additional information. Never use engine or carburetor cleaner products in the fuel tank or permanent damage may occur.

TO START ENGINE (See Fig. 8)



CAUTION: Keep tine control in "OFF" position when starting engine.

When starting engine for the first time or if engine has run out of fuel, it will take extra pulls of the recoil starter to move fuel from the tank to the engine.

- Make sure spark plug wire is properly connected.
- Place throttle control in "FAST" position.
- Move choke control to full "CHOKE" position. Grasp recoil starter handle with one hand and grasp tiller handle with other hand. Pull rope out slowly until engine reaches start of compression cycle (rope will pull slightly harder at this point).
- Pull recoil starter handle quickly. Do not let starter handle snap back against starter. Repeat if necessary.
- If engine fires but does not start, move choke control to half choke position. Pull recoil starter handle until engine starts.
- When engine starts, slowly move choke control to "RUN" position as engine warms up.

NOTE: A warm engine requires less choking to start.

- Move throttle control to desired running position.
- Allow engine to warm up for a few minutes before engaging tines.

NOTE: If at a high altitude (3000 feet) or in cold temperatures (below 32°F/0°C), the carburetor fuel mixture may need to be adjusted for best engine performance. See "TO ADJUST CARBURETOR" in the Service and Adjustments section of this manual.

NOTE: If engine does not start, see troubleshooting points.

OPERATION

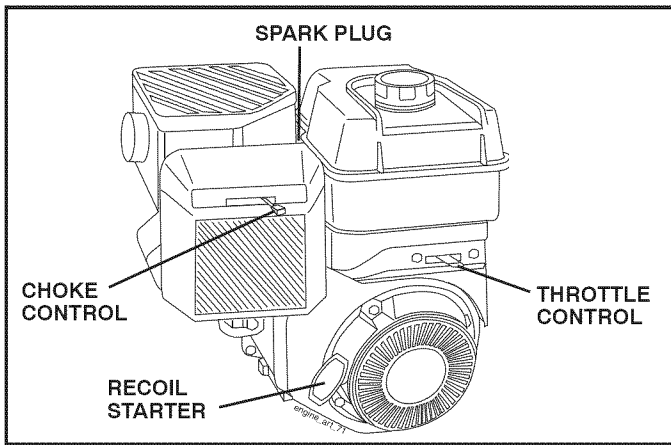

Fig. 8

BREAKING IN YOUR TILLER

Break-in your belt(s), pulleys and tine control before you actually begin tilling.

- Start engine, tip tines off ground by pressing handles down and engage tine control to start tine rotation. Allow tines to rotate for five minutes.
- Check tine operation and adjust if necessary. See "TINE OPERATION CHECK" in the Service and Adjustments section of this manual.

TILLING HINTS



CAUTION: Until you are accustomed to handling your tiller, start actual field use with throttle in slow position.

To help tiller move forward, lift up the handles slightly (thus lifting depth stake out of ground). To slow down the tiller, press down on handles.

If you are straining or tiller is shaking, the wheels and depth stake are not set properly in the soil being tilled. The proper setting of the wheels and depth stake is through trial and error and depends upon the soil condition. (The harder or wetter the ground, the slower the engine and tine speed needed. Under these poor conditions, at fast speed the tiller will run and jump over the ground).

A properly adjusted tiller will dig with little effort from the operator.

- Tilling is digging into, turning over, and breaking up packed soil before planting. Loose, unpacked soil helps root growth. Best tilling depth is 4"-6". A tiller will also clear the soil of unwanted vegetation. The decomposition of this vegetable matter enriches the soil. Depending on the climate (rainfall and wind), it may be advisable to till the soil at the end of the growing season to further condition the soil.
- Soil conditions are important for proper tilling. Tines will not readily penetrate dry, hard soil which may contribute to excessive bounce and difficult handling of your tiller. Hard soil should be moistened before tilling; however, extremely wet soil will "ball-up" or clump during tilling. Wait until the soil is less wet in order to achieve the best results. When tilling in the fall, remove vines and long grass to prevent them from wrapping around the tine shaft and slowing your tilling operation.

- You will find tilling much easier if you leave a row untilled between passes. Then go back between tilled rows. (See Fig. 9) There are two reasons for doing this. First, wide turns are much easier to negotiate than about-faces. Second, the tiller won't be pulling itself, and you, toward the row next to it.
- Set depth stake and wheel height for shallow tilling when working extremely hard soil or sod. Then work across the first cuts at normal depth.

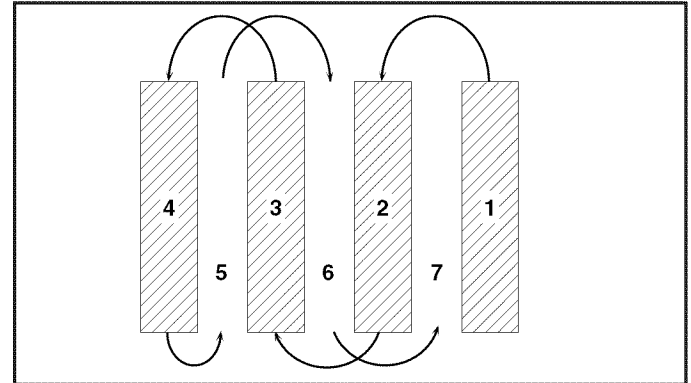

Fig. 9

CULTIVATING

Cultivating is destroying the weeds between rows to prevent them from robbing nourishment and moisture from the plants. At the same time, breaking up the upper layer of soil crust will help retain moisture in the soil. Best digging depth is 1"-3".

- You will probably not need to use the depth stake. Begin by tipping the depth stake forward until it is held by the stake spring.
- Cultivate up and down the rows at a speed which will allow tines to uproot weeds and leave the ground in rough condition, promoting no further growth of weeds and grass (See Fig. 10).

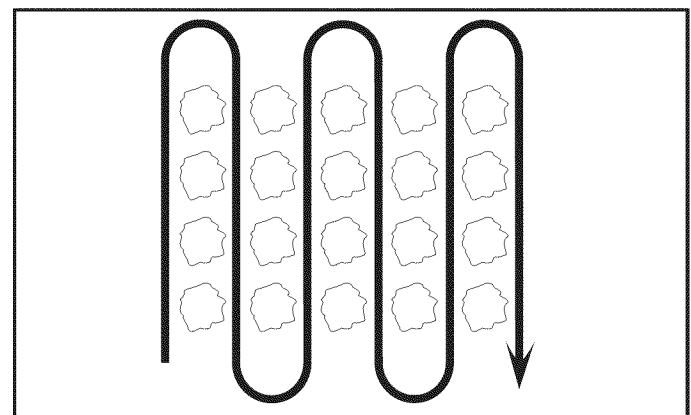

Fig. 10

MAINTENANCE

MAINTENANCE SCHEDULE	SERVICE DATES											
FILL IN DATES AS YOU COMPLETE REGULAR SERVICE	BEFORE EACH USE	EVERY 5 HOURS	EVERY 25 HOURS	EVERY 50 HOURS								
Check Engine Oil Level	✓	✓										
Change Engine Oil				✓ _{1,2}								
Oil Pivot Points		✓										
Inspect Spark Arrester / Muffler				✓								
Inspect Air Screen	✓											
Clean or Replace Air Cleaner Cartridge				✓ ₂								
Clean Engine Cylinder Fins				✓								
Replace Spark Plug				✓								

1 - Change more often when operating under a heavy load or in high ambient temperatures.
 2 - Service more often when operating in dirty or dusty conditions.

GENERAL RECOMMENDATIONS

The warranty on this tiller does not cover items that have been subjected to operator abuse or negligence. To receive full value from the warranty, operator must maintain tiller as instructed in this manual.

Some adjustments will need to be made periodically to properly maintain your tiller.

All adjustments in the Service and Adjustments section of this manual should be checked at least once each season.

- Once a year you should replace the spark plug, clean or replace air filter, and check tines and belt for wear. A new spark plug and clean air filter assure proper air-fuel mixture and help your engine run better and last longer.

BEFORE EACH USE

- Check engine oil level.
- Check tine operation.
- Check for loose fasteners.

LUBRICATION

Keep unit well lubricated (See "LUBRICATION CHART")

LUBRICATION CHART

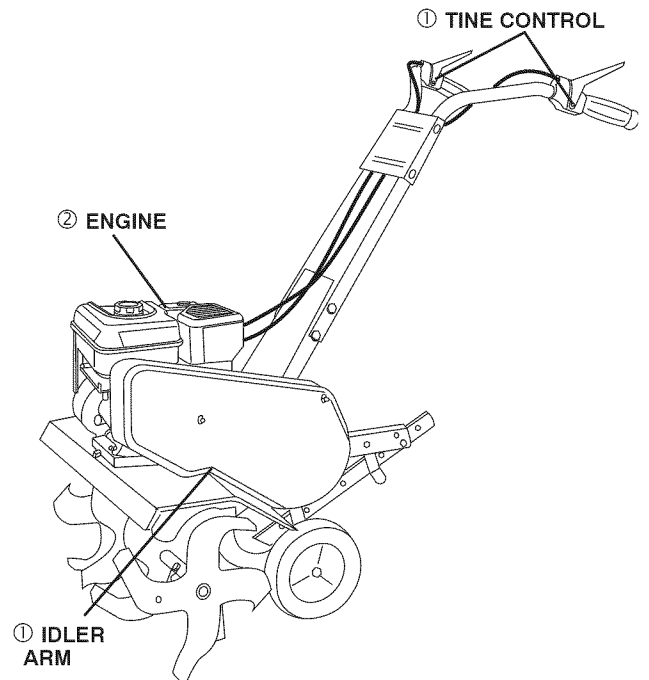

- ① SAE 30 OR 10W-30 MOTOR OIL
- ② REFER TO MAINTENANCE "ENGINE" SECTION

MAINTENANCE



Disconnect spark plug wire before performing any maintenance (except carburetor adjustment) to prevent accidental starting of engine.

Prevent fires! Keep the engine free of grass, leaves, spilled oil, or fuel. Remove fuel from tank before tipping unit for maintenance. Clean muffler area of all grass, dirt, and debris.

Do not touch hot muffler or cylinder fins as contact may cause burns.

ENGINE

LUBRICATION

Use only high quality detergent oil rated with API service classification SG-SL. Select the oil's SAE viscosity grade according to your expected temperature.

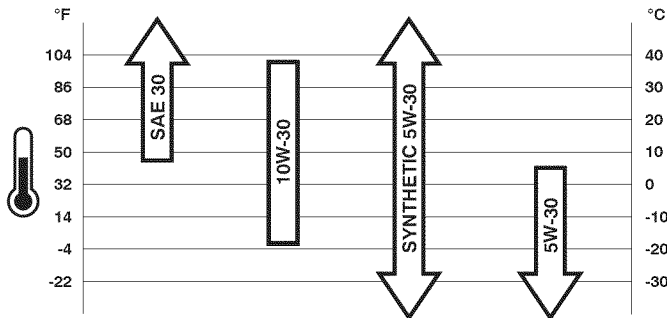

Fig. 11

NOTE: Although multi-viscosity oils (5W-30, 10W-30, etc.) improve starting in cold weather, these multi-viscosity oils will result in increased oil consumption when used above 32°F (0°C). Check your engine oil level more frequently to avoid possible engine damage from running low on oil.

Change the oil after every 50 hours of operation or at least once a year if the tiller is not used for 50 hours in one year.

Check the crankcase oil level before starting the engine and after each five (5) hours of continuous use. Add SAE 30 motor oil or equivalent. Tighten oil filler plug securely each time you check the oil level.

TO CHANGE ENGINE OIL (See Figs. 11 and 12)

Determine temperature range expected before oil change. All oil must meet API service classification SG-SL.

- Be sure tiller is on level surface.
- Oil will drain more freely when warm.
- Catch oil in a suitable container.
- Remove drain plug.
- Tip tiller forward to drain oil.
- After oil has drained completely, replace oil drain plug and tighten securely.
- Remove oil filler plug. Be careful not to allow dirt to enter the engine.
- Refill engine with oil. See "FILL ENGINE WITH OIL" in the Operation section of this manual.

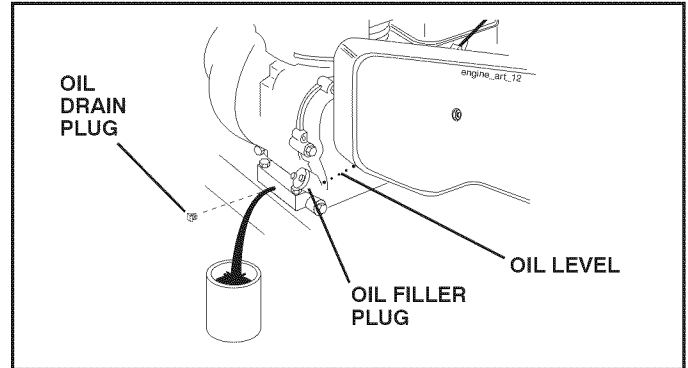

Fig. 12

AIR CLEANER (See Fig. 13)

Service air cleaner cartridge every 50 hours, more often if engine is used in very dusty conditions.

- Loosen air cleaner screws, one on each side of cover.
- Remove air cleaner cover.
- Carefully remove air cleaner cartridge. Be careful. Do not allow dirt or debris to fall into carburetor.
- Clean by tapping gently on a flat surface.
- If very dirty or damaged, replace cartridge.
- Clean and replace cover. Tighten screws securely.



CAUTION: Petroleum solvents, such as kerosene, are not to be used to clean cartridge. They may cause deterioration of the cartridge. Do not oil cartridge. Do not use pressurized air to clean or dry cartridge.

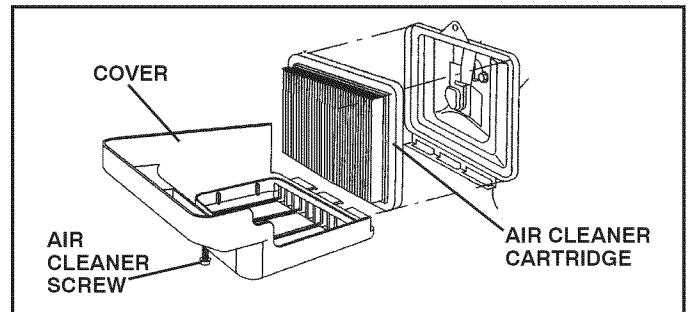

Fig. 13

MAINTENANCE

COOLING SYSTEM (See Fig. 14)

Your engine is air cooled. For proper engine performance and long life keep your engine clean.

- Clean air screen frequently using a stiff-bristled brush.
- Remove blower housing and clean as necessary.
- Keep cylinder fins free of dirt and chaff.

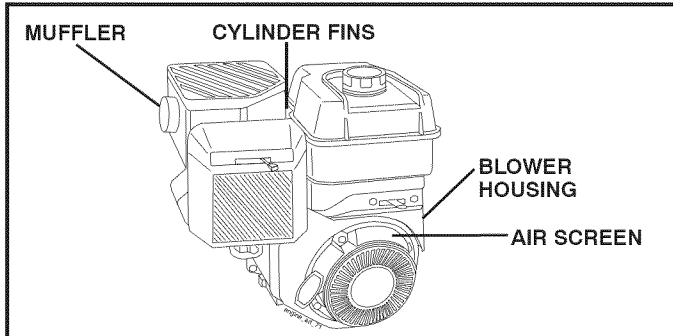

Fig. 14

MUFFLER

Do not operate tiller without muffler. Do not tamper with exhaust system. Damaged mufflers or spark arresters could create a fire hazard. Inspect periodically and replace if necessary. If your engine is equipped with a spark arrester screen assembly, remove every 50 hours for cleaning and inspection. Replace if damaged.

SPARK PLUG

Replace spark plugs at the beginning of each tilling season or after every 50 hours of use, whichever comes first. Spark plug type and gap setting is shown in "PRODUCT SPECIFICATIONS" on page 3 of this manual.

TRANSMISSION

Your transmission is sealed and will only require lubrication if it is serviced.

CLEANING

Do not clean your tiller when the engine and transmission are hot. We do not recommend using pressurized water (garden hose, etc.) to clean your unit unless the gasket area around the transmission and the engine muffler, air filter and carburetor are covered to keep water out. Water in engine will shorten the useful life of your tiller.

- Clean engine, wheels, finish, etc. of all foreign matter.
- Keep finished surfaces and wheels free of all gasoline, oil, etc.
- Protect painted surfaces with automotive type wax.

SERVICE AND ADJUSTMENTS



CAUTION: Disconnect spark plug wire from spark plug and place wire where it cannot come into contact with plug.

TILLER

TO ADJUST HANDLE HEIGHT (See Fig. 15)

Factory assembly has provided lowest handle height. Select handle height best suited for your tilling conditions. Handle height will be different when tiller digs into soil.

- If a higher handle height is desired, loosen the four nuts securing handle panel to engine brackets.
- Slide handle panel to desired location.
- Tighten the four nuts securely.

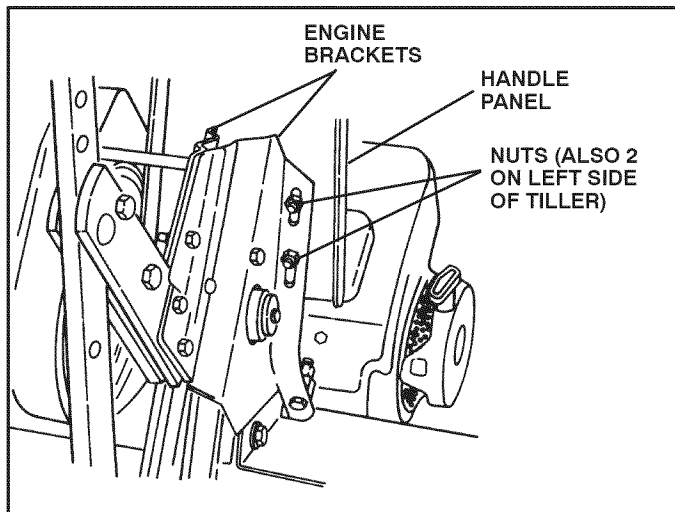

Fig. 15

TINE ARRANGEMENT

Your outer tines can be assembled in several different ways to suit your tilling or cultivating needs.



CAUTION: Tines are sharp. Wear gloves or other protection when handling tines.

NORMAL TILLING - 26" PATH (See Fig. 16)

- Assemble holes "A" in tine hubs to holes "B" in tine shaft.

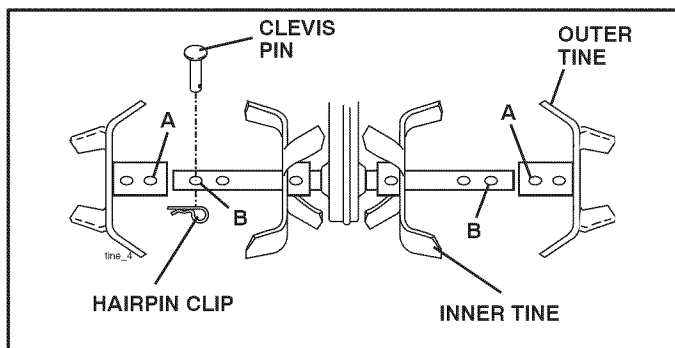

Fig. 16

MID-WIDTH TILLING - 24" PATH (See Fig. 17)

- Assemble holes "A" in tine hubs to holes "C" in tine shaft.

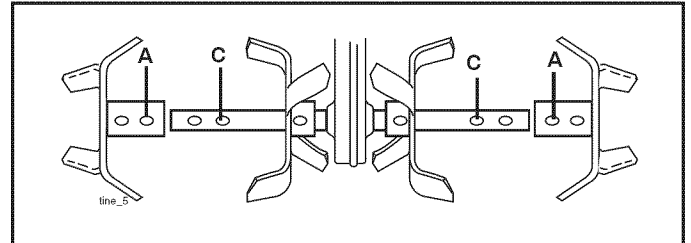

Fig. 17

NARROW TILLING/CULTIVATING - 12-3/4" PATH (See Fig. 18)

- Remove outer tines.

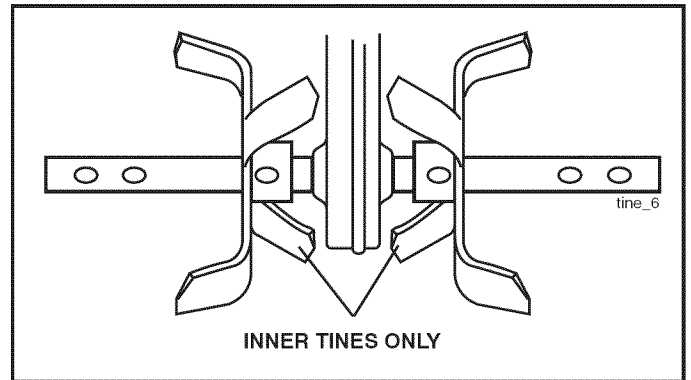

Fig. 18

NOTE: When reassembling outer tines, be sure right tine assembly (marked "R") and left tine assembly (marked "L") are mounted to correct side of tine shaft.

SERVICE AND ADJUSTMENTS

TO REMOVE BELT GUARD (See Fig. 19)

- Remove two (2) cap nuts and washers from side of belt guard.
- Loosen (do not remove) tine shield nut on underside of tine shield.
- Pull belt guard out and away from unit.
- Replace belt guard by reversing above procedure. Be sure slot in bottom of belt guard is under head of tine shield bolt and all nuts are tightened securely.

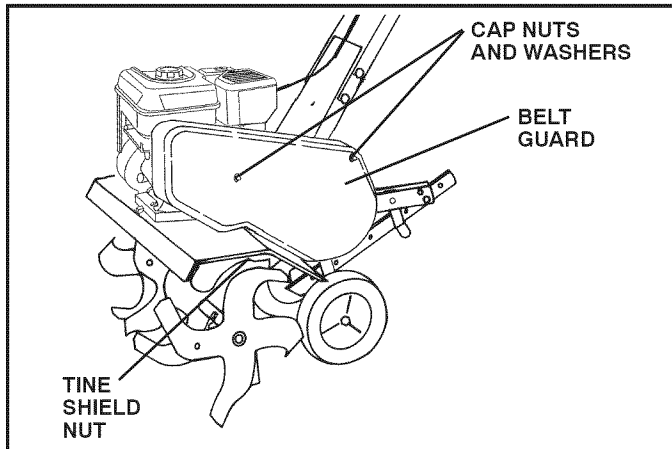

Fig. 19

TINE OPERATION CHECK (See Fig. 20)



WARNING: Disconnect spark plug wire from spark plug to prevent starting while checking tine operation.

For proper tine operation, forward tine control lever must be against control body and all slack removed from inner wire of control cable when control is in the "OFF" (up) position.

If lever and cable are loose, loosen cable clip at lower end of cable. Pull up on cable to remove slack, without extending spring on end of cable, and retighten cable clip.

FINAL CHECK "OFF" POSITION

- With tine control "OFF" (up), push down on handle to raise tines off the ground.
- Slowly pull recoil starter handle while observing tines. Tines should not rotate.
- If tines rotate, inner wire of control cable is too tight which is extending lower spring and engaging tines. Loosen cable clip and push down on cable only enough to relieve spring tension. Tighten cable clip.
- Recheck in "OFF" position and adjust if necessary.

FINAL CHECK "ON" POSITION

- With tine control "ON" (held down to handle) push down on handle to raise tines off the ground.
- Slowly pull recoil starter handle while observing tines. Tines should rotate forward.
- If tines do not rotate, inner wire of control cable is too loose. Loosen cable clip and pull cable up to remove slack and retighten clip.

- Recheck in "ON" position and adjust if necessary.

NOTE: If "ON" position check required adjustment, recheck "OFF" position adjustment to insure tines do not rotate when control is "OFF" (up).

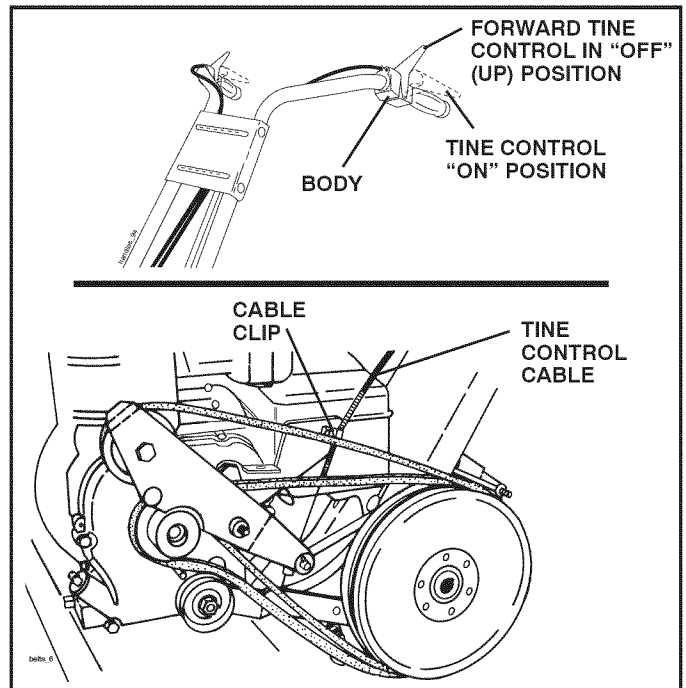

Fig. 20

TO REPLACE V-BELTS (See Figs. 21 and 22)

Replace V-belts if they have stretched considerably or if they show cracks or frayed edges. There are two (2) V-belts - forward (inside) and reverse (outside).

Belt guard must be removed to service belts. See "TO REMOVE BELT GUARD" in this section of manual.

NOTE: Observe carefully routing of both belts and location of all belt guides before removing belts.

BELT REMOVAL

- Remove reverse idler pulley from idler arm.
- Remove reverse (outside) V-belt.
- Remove forward (inside) V-belt from transmission pulley first and then from engine pulley.

BELT REPLACEMENT

- Install new forward (inside) V-belt to engine pulley first then to transmission pulley. Be sure belt is positioned on inside groove of both pulleys, inside all belt guides and rests on idler pulley.
- Before installing reverse (outside) V-belt, turn belt "inside out". Twist so wide, flat surface of belt is to inside.
- Wrap V-belt around reverse idler pulley and reassemble idler to idler arm. Tighten securely. Be sure belt is between reverse idler pulley and idler arm pin.
- Install belt to outside groove of transmission pulley. Be sure belt is inside all belt guides and rests on outside groove of engine pulley.

SERVICE AND ADJUSTMENTS

CHECK TINE OPERATION

- See "TINE OPERATION CHECK" in this section of manual.

REPLACE BELT GUARD

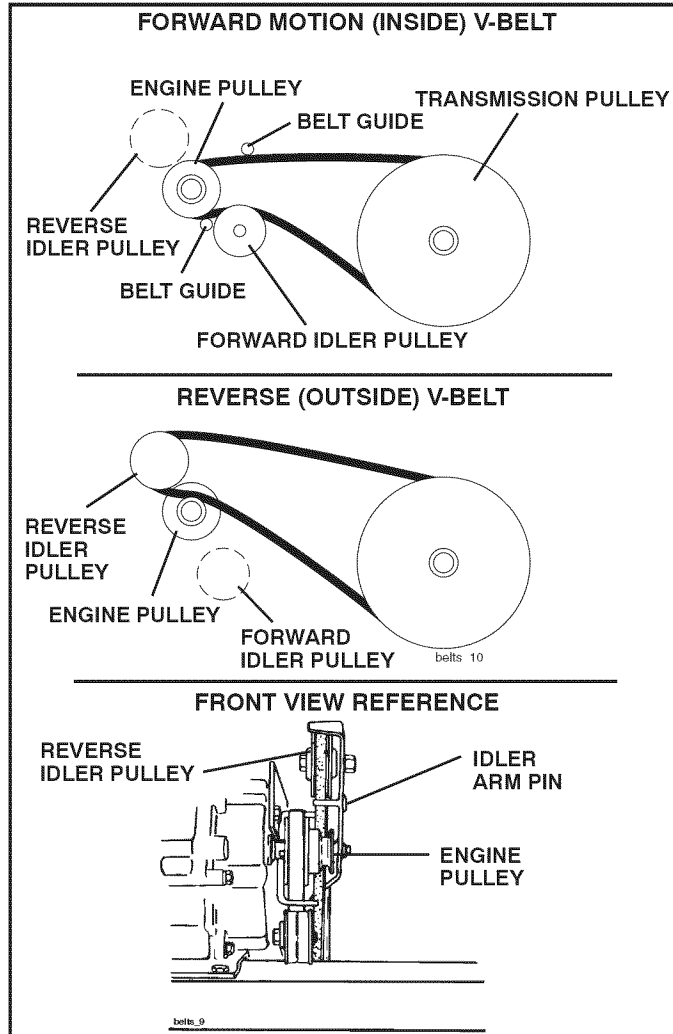

Fig. 21

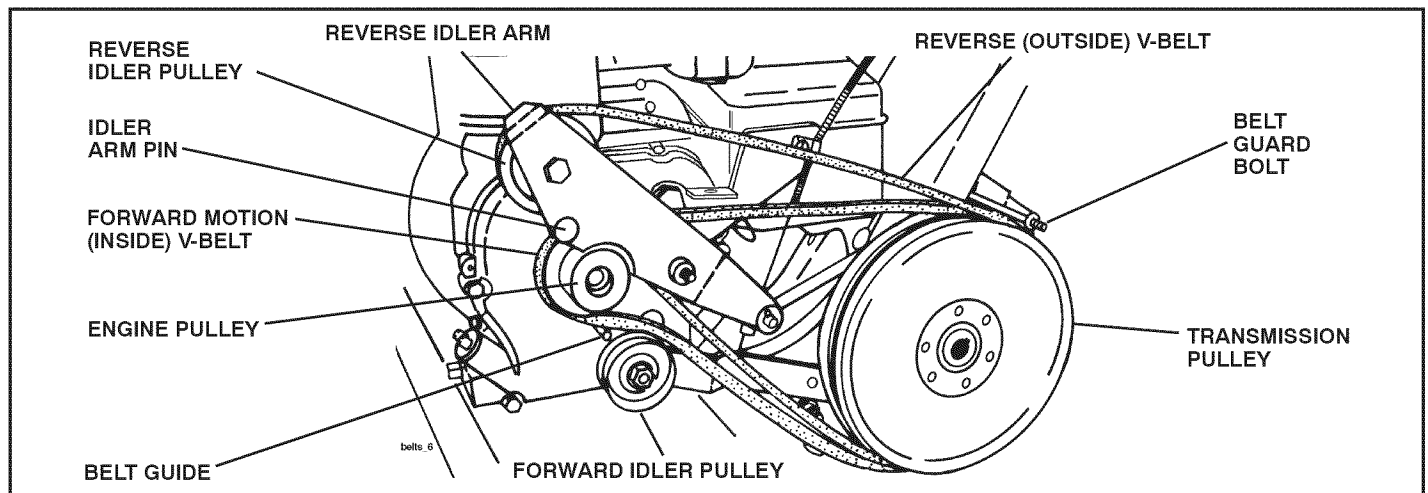

Fig. 22

ENGINE

Maintenance, repair, or replacement of the emission control devices and systems, which are being done at the customer's expense, may be performed by any non-road engine repair establishment or individual. Warranty repairs must be performed by an authorized engine manufacturer's service outlet.

TO ADJUST CARBURETOR

The carburetor has been preset at the factory and adjustment should not be necessary. However, engine performance can be affected by differences in fuel, temperature, altitude or load. If the carburetor does need adjustment, contact your nearest authorized service center/department.

IMPORTANT: NEVER TAMPER WITH THE ENGINE GOVERNOR, WHICH IS FACTORY SET FOR PROPER ENGINE SPEED. OVERSPEEDING THE ENGINE ABOVE THE FACTORY HIGH SPEED SETTING CAN BE DANGEROUS. IF YOU THINK THE ENGINE-GOVERNED HIGH SPEED NEEDS ADJUSTING, CONTACT YOUR NEAREST AUTHORIZED SERVICE CENTER/DEPARTMENT, WHICH HAS THE PROPER EQUIPMENT AND EXPERIENCE TO MAKE ANY NECESSARY ADJUSTMENTS.

STORAGE

Immediately prepare your tiller for storage at the end of the season or if the unit will not be used for 30 days or more.



WARNING: Never store the tiller with gasoline in the tank inside a building where fumes may reach an open flame or spark. Allow the engine to cool before storing in any enclosure.

TILLER

- Clean entire tiller (See "CLEANING" in the Maintenance section of this manual).
- Inspect and replace belts, if necessary (See belt replacement instructions in the Service and Adjustments section of this manual).
- Lubricate as shown in the Maintenance section of this manual.
- Be sure that all nuts, bolts and screws are securely fastened. Inspect moving parts for damage, breakage and wear. Replace if necessary.
- Touch up all rusted or chipped paint surfaces; sand lightly before painting.

ENGINE

FUEL SYSTEM

IMPORTANT: IT IS IMPORTANT TO PREVENT GUM DEPOSITS FROM FORMING IN ESSENTIAL FUEL SYSTEM PARTS SUCH AS THE CARBURETOR, FUEL FILTER, FUEL HOSE, OR TANK DURING STORAGE. ALSO, EXPERIENCE INDICATES THAT ALCOHOL BLENDED FUELS (CALLED GASOHOL OR USING ETHANOL OR METHANOL) CAN ATTRACT MOISTURE WHICH LEADS TO SEPARATION AND FORMATION OF ACIDS DURING STORAGE. ACIDIC GAS CAN DAMAGE THE FUEL SYSTEM OF AN ENGINE WHILE IN STORAGE.

- Drain the fuel tank.
- Start the engine and let it run until the fuel lines and carburetor are empty.
- Never use engine or carburetor cleaner products in the fuel tank or permanent damage may occur.

NOTE: Fuel stabilizer is an acceptable alternative in minimizing the formation of fuel gum deposits during storage. Add stabilizer to gasoline in fuel tank or storage container. Always follow the mix ratio found on stabilizer container. Run engine at least 10 minutes after adding stabilizer to allow the stabilizer to reach the carburetor. Do not drain the gas tank and carburetor if using fuel stabilizer.

ENGINE OIL

Drain oil (with engine warm) and replace with clean oil. (See "ENGINE" in the Maintenance section of this manual).

CYLINDER(S)

- Remove spark plug.
- Pour 1 ounce (29 ml) of oil through spark plug hole into cylinder.
- Pull starter handle slowly several times to distribute oil.
- Replace with new spark plug.

OTHER

- Do not store gasoline from one season to another.
- Replace your gasoline can if your can starts to rust. Rust and/or dirt in your gasoline will cause problems.
- If possible, store your unit indoors and cover it to give protection from dust and dirt.
- Cover your unit with a suitable protective cover that does not retain moisture. Do not use plastic. Plastic cannot breathe which allows condensation to form and will cause your unit to rust.

IMPORTANT: NEVER COVER TILLER WHILE ENGINE AND EXHAUST AREAS ARE STILL WARM.

TROUBLESHOOTING POINTS

PROBLEM	CAUSE	CORRECTION
Will not start	<ol style="list-style-type: none"> 1. Out of fuel. 2. Engine not "CHOKED" properly. 3. Engine flooded. 4. Dirty air cleaner. 5. Water in fuel. 6. Clogged fuel tank. 7. Loose spark plug wire. 8. Bad spark plug or improper gap. 9. Carburetor out of adjustment. 	<ol style="list-style-type: none"> 1. Fill fuel tank. 2. See "TO START ENGINE" in the Operation section. 3. Wait several minutes before attempting to start. 4. Clean or replace air cleaner cartridge. 5. Drain fuel tank and carburetor, and refill tank with fresh gasoline. 6. Remove fuel tank and clean. 7. Make sure spark plug wire is seated properly on plug. 8. Replace spark plug or adjust gap. 9. Make necessary adjustments.
Hard to start	<ol style="list-style-type: none"> 1. Throttle control not set properly. 2. Dirty air cleaner. 3. Bad spark plug or improper gap. 4. Stale or dirty fuel. 5. Loose spark plug wire. 6. Carburetor out of adjustment. 	<ol style="list-style-type: none"> 1. Place throttle control in "FAST" position. 2. Clean or replace air cleaner cartridge. 3. Replace spark plug or adjust gap. 4. Drain fuel tank and refill with fresh gasoline. 5. Make sure spark plug wire is seated properly on plug. 6. Make necessary adjustments.
Loss of power	<ol style="list-style-type: none"> 1. Engine is overloaded. 2. Dirty air cleaner. 3. Low oil level/dirty oil. 4. Faulty spark plug. 5. Oil in fuel. 6. Stale or dirty fuel. 7. Water in fuel. 8. Clogged fuel tank. 9. Spark plug wire loose. 10. Dirty engine air screen. 11. Dirty/clogged muffler. 12. Carburetor out of adjustment. 13. Poor compression. 	<ol style="list-style-type: none"> 1. Set depth stake and wheels for shallower tilling. 2. Clean or replace air cleaner cartridge. 3. Check oil level/change oil. 4. Clean and regap or change spark plug. 5. Drain and clean fuel tank and refill, and clean carburetor. 6. Drain fuel tank and refill with fresh gasoline. 7. Drain fuel tank and carburetor, and refill tank with fresh gasoline. 8. Remove fuel tank and clean. 9. Connect and tighten spark plug wire. 10. Clean engine air screen. 11. Clean/replace muffler. 12. Make necessary adjustments. 13. Contact an authorized service center/department.
Engine overheats	<ol style="list-style-type: none"> 1. Low oil level/dirty oil. 2. Dirty engine air screen. 3. Dirty engine. 4. Partially plugged muffler. 5. Improper carburetor adjustment. 	<ol style="list-style-type: none"> 1. Check oil level/change oil. 2. Clean engine air screen. 3. Clean cylinder fins, air screen, muffler area. 4. Remove and clean muffler. 5. Adjust carburetor to richer position.
Excessive bounce/ difficult handling	<ol style="list-style-type: none"> 1. Ground too dry and hard. 2. Wheels and depth stake incorrectly adjusted. 	<ol style="list-style-type: none"> 1. Moisten ground or wait for more favorable soil conditions. 2. Adjust wheels and depth stake.
Soil balls up or clumps	<ol style="list-style-type: none"> 1. Ground too wet. 	<ol style="list-style-type: none"> 1. Wait for more favorable soil conditions.
Engine runs but tiller won't move	<ol style="list-style-type: none"> 1. Tine control is not engaged. 2. V-belt not correctly adjusted. 3. V-belt is off pulley(s). 	<ol style="list-style-type: none"> 1. Engage tine control. 2. Inspect/adjust V-belt. 3. Inspect V-belt.
Engine runs but labors when tilling	<ol style="list-style-type: none"> 1. Tilling too deep. 2. Throttle control not properly adjusted. 3. Carburetor out of adjustment. 	<ol style="list-style-type: none"> 1. Set depth stake for shallower tilling. 2. Check throttle control setting. 3. Make necessary adjustments.

TILLER - MODEL NO. 917.250090

HANDLE ASSEMBLY

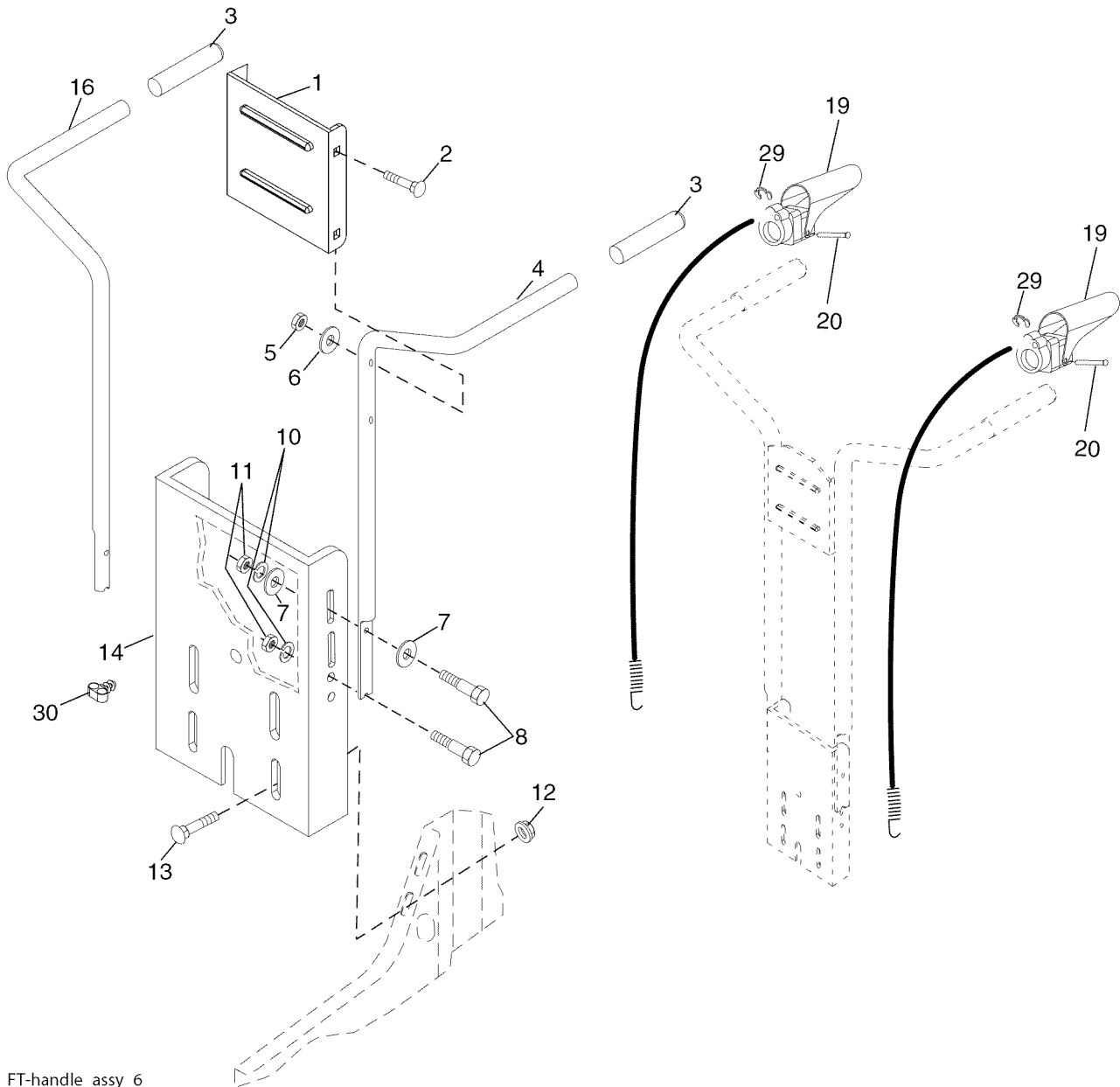

FT-handle_assy_6

KEY NO.	PART NO.	DESCRIPTION
1	137176X668	Panel, Control
2	72140512	Bolt, RDHD 5/16-18 x 1 1/2
3	165787	Grip, Handle
4	166376X498	Handle, LH Double Bend
5	73680500	Nut, Crown Lock 5/16 -18
6	19111116	Washer 11/32 x 11/16 x 16 Ga.
7	19121414	Washer 3/8 x 7/8 x 14 Ga.
8	74760520	Bolt Fin Hx 5/16-18 x 1.25
10	10040500	Washer Lock 5/16
11	73220500	Nut, Fln Hx 5/16-18
12	98000129	Nut, Flange

KEY NO.	PART NO.	DESCRIPTION
13	180847	Bolt, RDHD 5/16-18 x 3/4
14	9209RX668	Assembly, Panel
16	166381X498	Handle, RH Double Bend
19	188562	Lever, Control, Tine
20	188555	Pin, Pivot
29	12000059	Retainer, Ring
30	181580	Routing Clip

NOTE: All component dimensions given in U.S. inches.
1 inch = 25.4 mm

TILLER - MODEL NO. 917.250090

BELT GUARD AND PULLEY ASSEMBLY

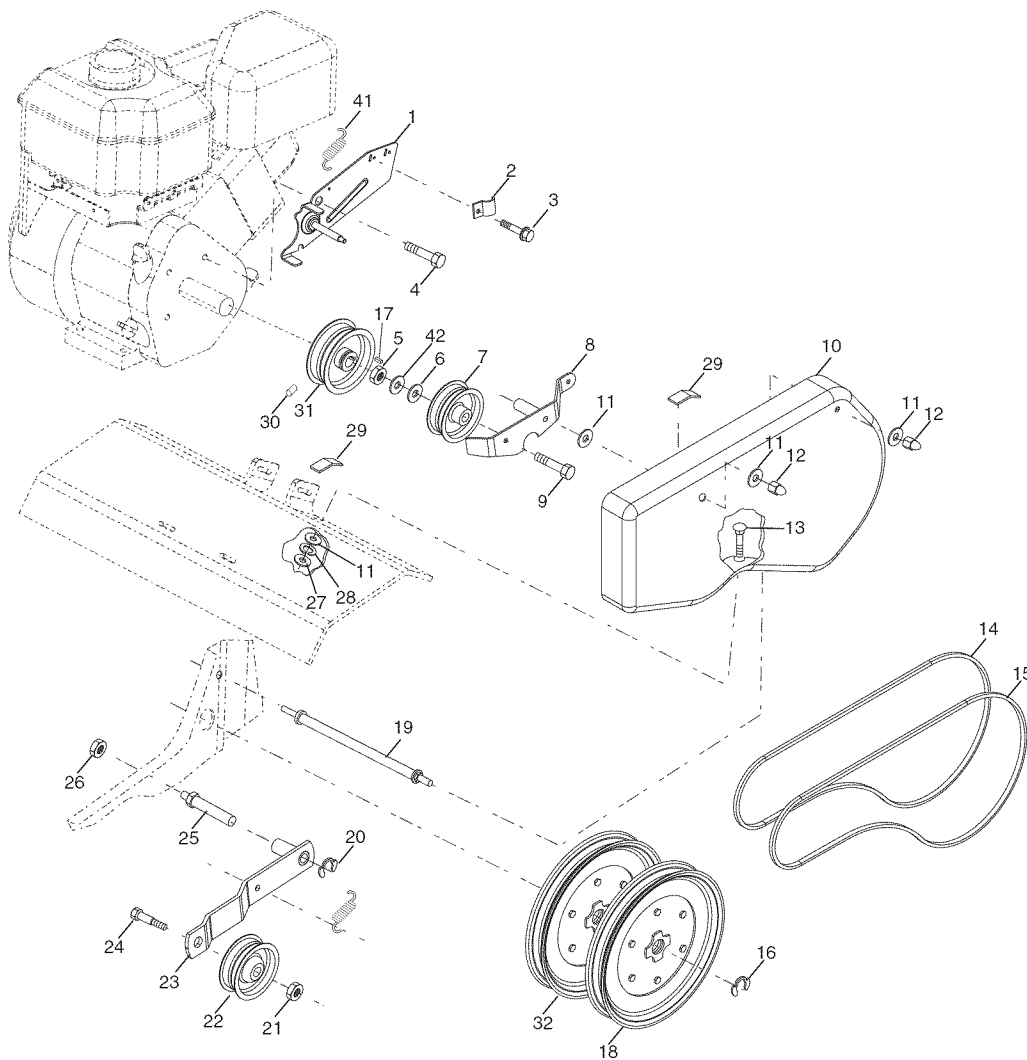

belt_guard_14

KEY NO.	PART NO.	DESCRIPTION	KEY NO.	PART NO.	DESCRIPTION
1	439162X479	Assembly, Bracket, Belt Guard	21	73350600	Nut, Hex, Jam 3/8-16
2	9484R	Clip, Cable	22	161806	Pulley, Idler
3	086777	Screw #10-24 x 1/2	23	175377X479	Arm, Idler
4	74610812	Bolt, Hex Head 1/2-20 x 3/4	24	74760620	Bolt 3/8-16 x 1-1/4
5	73680600	Nut, Lock 3/8-16	25	106968	Shaft, Idler Arm
6	19131316	Washer 13/32 x 13/16 x 16 Ga.	26	73350500	Nut, Hex, Jam 5/16-18
7	2009J	Pulley, Idler, Reverse	27	73220400	Nut, Hex 1/4-20
8	159238X479	Assembly, Arm, Reverse Idler	28	10040400	Washer, Lock 1/4
9	74780632	Cap screw, Hex Head 3/8-16 x 2.00	29	109227X	Pad, Idler
10	194630X668	Guard, Belt	30	23200404	Screw, Set, Socket, Headless C.P. 1/4-20 x 1/4
11	19091016	Washer 9/32 x 5/8 x 16 Ga.	31	101189L	Sheave, Engine
12	104213X	Nut, Cap 1/4-20	32	151223	Sheave, Transmission "Flat"
13	72140406	Bolt, Carriage 1/4-20 x 3/4	41	180307	Spring Extension
14	133035	V-Belt (Forward Motion)	42	138909	Spacer
15	2614J	V-Belt (Reverse)			
16	12000028	Ring, Retainer			
17	2649M	Key, Square			
18	151236	Sheave, Transmission "Flat"			
19	188502	Bolt, Belt Guard			
20	12000036	Ring, Clip			

NOTE: All component dimensions given in U.S. inches.
1 inch = 25.4 mm

TILLER - MODEL NO. 917.250090
WHEEL AND DEPTH STAKE ASSEMBLY

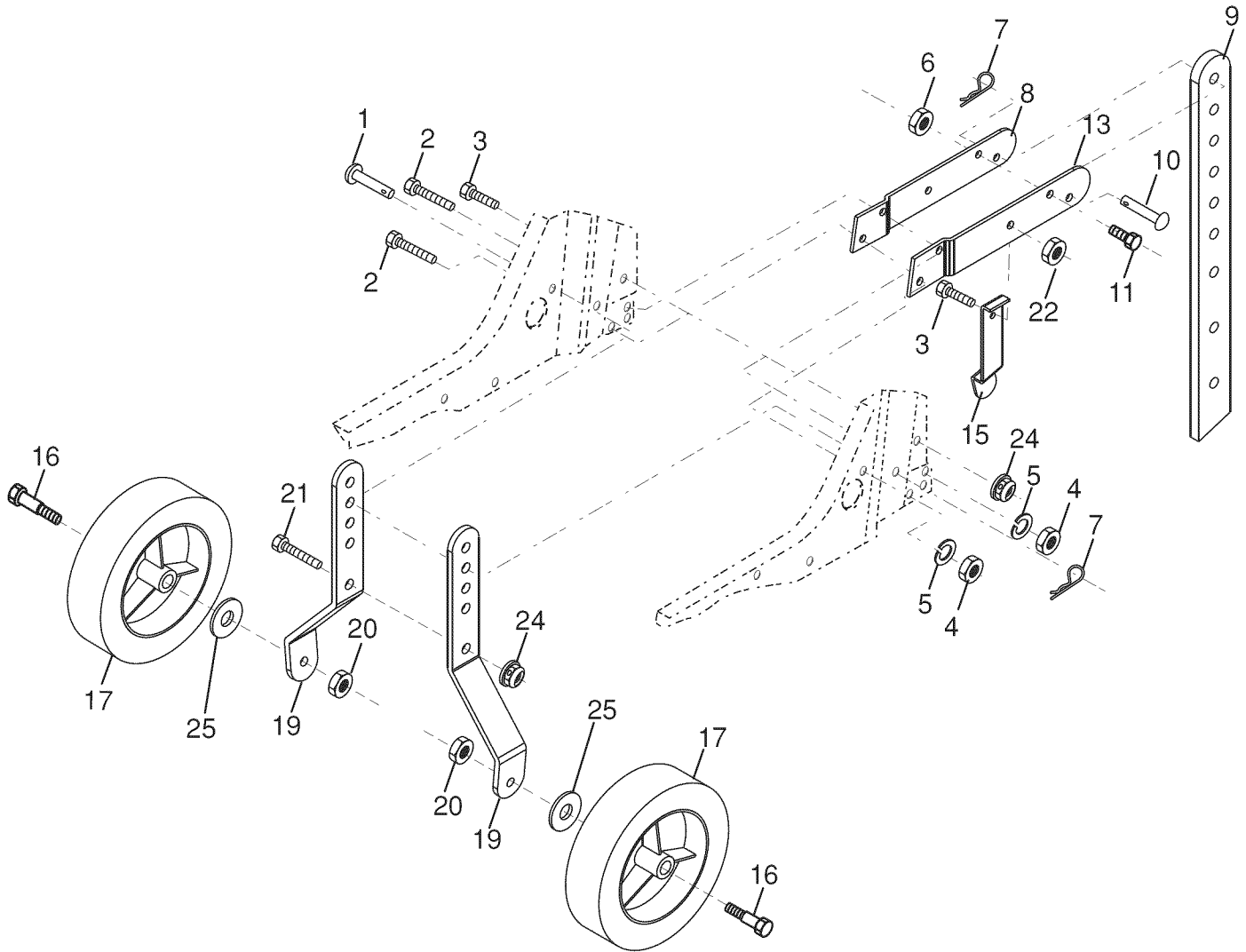

wheel_d.stake_9

KEY NO.	PART NO.	DESCRIPTION
1	9194R	Pin, Clevis
2	74760520	Bolt, Hex Head 5/16-18 x 1-1/4
3	74760512	Bolt, Hex Head 5/16-18 x 3/4
4	73220500	Nut, Hex 5/16-18
5	10040500	Washer, Lock 5/16
6	73800600	Locknut, w/washer 3/8-16
7	4921H	Clip, Hairpin
8	1952JX479	Support, Depth Stake, R.H.
9	122233X479	Stake, Depth
10	4929H	Pin, Clevis
11	74780628	Bolt, Hex 3/8-16 x 1-3/4
13	1951JX479	Support, Depth Stake, L.H.

KEY NO.	PART NO.	DESCRIPTION
15	5388JX004	Spring, Stake
16	121117X	Bolt, Shoulder
17	193851X613	Wheel
19	9190RX479	Bracket, Wheel
20	73680600	Locknut, Crown 3/8-16
21	74760516	Bolt, Hex Head 5/16-18 x 1
22	73800500	Locknut, w/insert 5/16-18
24	73970500	Locknut, Flange 5/16-18 unc
25	19171416	Washer 17/32 x 7/8 x 16 Ga.

NOTE: All component dimensions given in U.S. inches.
 1 inch = 25.4 mm

TILLER - MODEL NO. 917.250090

TINE ASSEMBLY

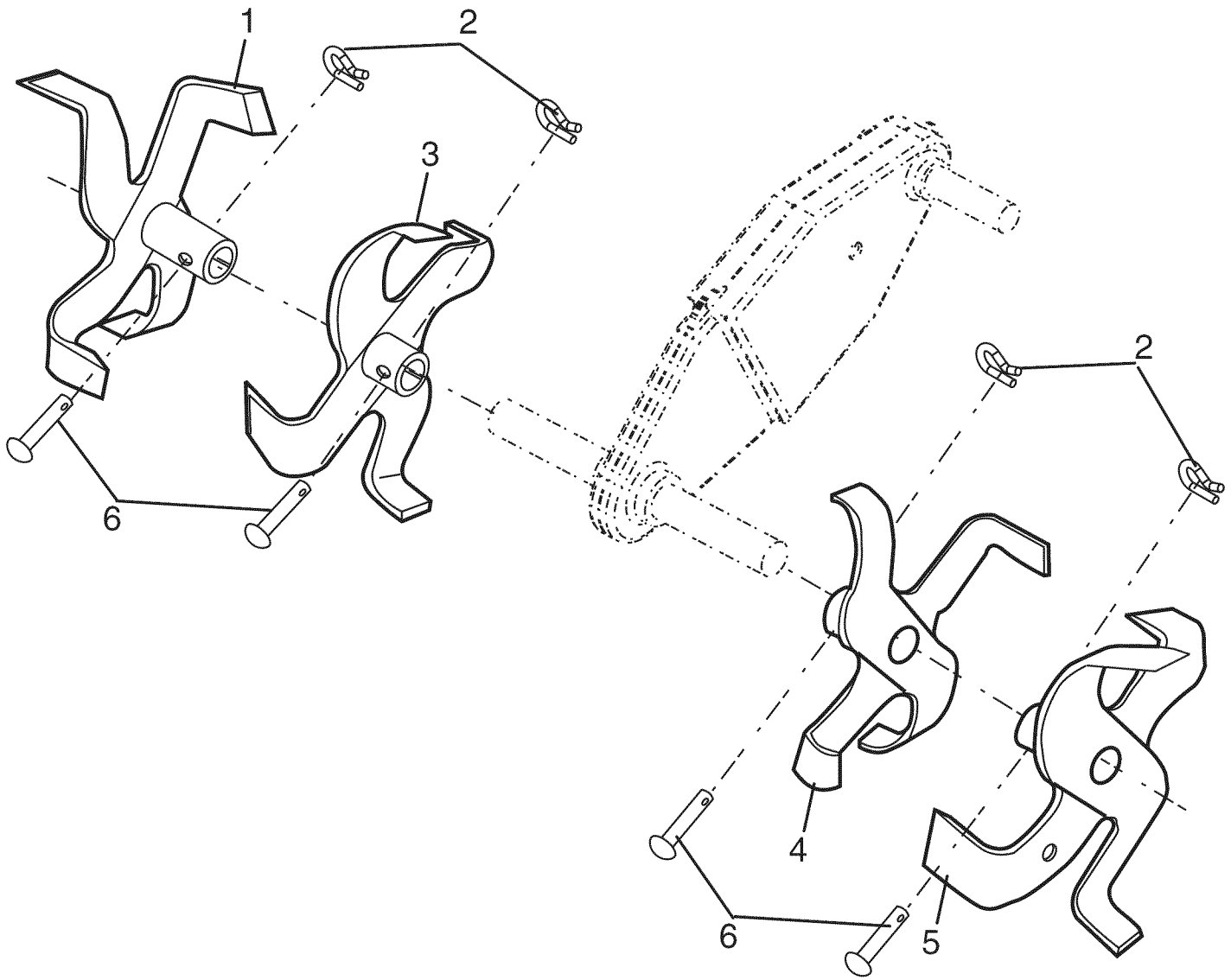

tine_ipb_3

KEY NO.	PART NO.	DESCRIPTION
1	156934X479	Tine, Outer, R.H.
2	3146R	Retainer, Spring
3	156932X479	Tine, Inner, R.H.
4	156931X479	Tine, Inner, L.H.
5	156933X479	Tine, Outer, L.H.
6	4929H	Rivet Pan Hd Drilled 1/4 Dia.

NOTE: All component dimensions given in U.S. inches.
1 inch = 25.4 mm

TILLER - MODEL NO. 917.250090

TRANSMISSION

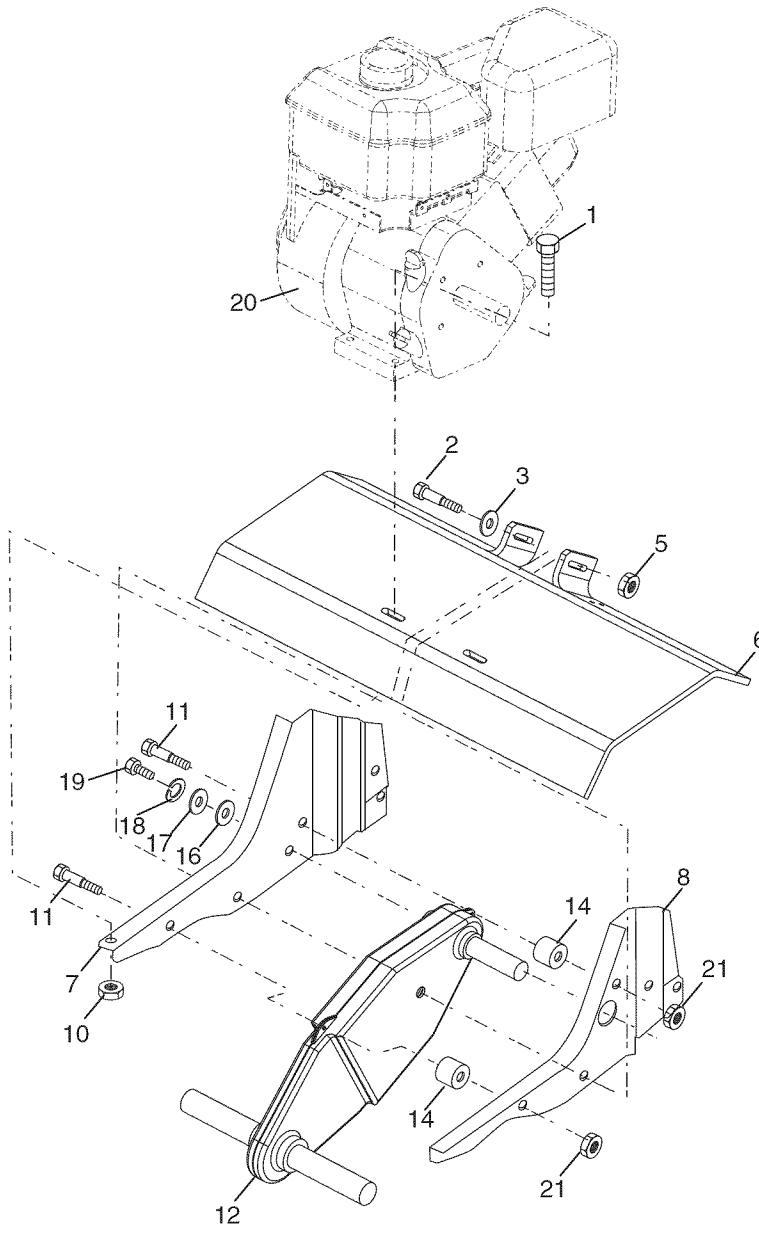

transmission_27

KEY NO.	PART NO.	DESCRIPTION
1	74760524	Bolt, Hex 5/16-18 x 1-1/2 Gr. 2
2	74780652	Bolt, Hex 3/8-16 x 3-1/4
3	19131311	Washer 13/32 x 13/16 x 11
5	73900600	Locknut 3/8-16
6	9057RX668	Shield, Tine
7	188195X479	Bracket, Engine, R.H.
8	165834X479	Bracket, Engine, L.H.
10	970500	Nut, Hex 5/16-18
11	187912	Bolt, Hex Head 5/16-18 x 2.5
12	151222	Transmission
14	446548	Spacer, Split

KEY NO.	PART NO.	DESCRIPTION
16	19091412	Washer 9/32 x 7/8 x 12 Ga.
17	19092016	Washer 9/32 x 1-1/4 x 16 Ga.
18	10040400	Washer, Lock 1/4
19	74610412	Bolt, Hex 1/4-28 x 3/4 Gr. 5
20	-----	Engine Briggs Model 12T402-1613-F8 (446085) (Order parts from engine manufacturer.)
21	751153	Nut 5/16-18

NOTE: All component dimensions given in U.S. inches.
1 inch = 25.4 mm

TILLER - MODEL NO. 917.250090

DECALS

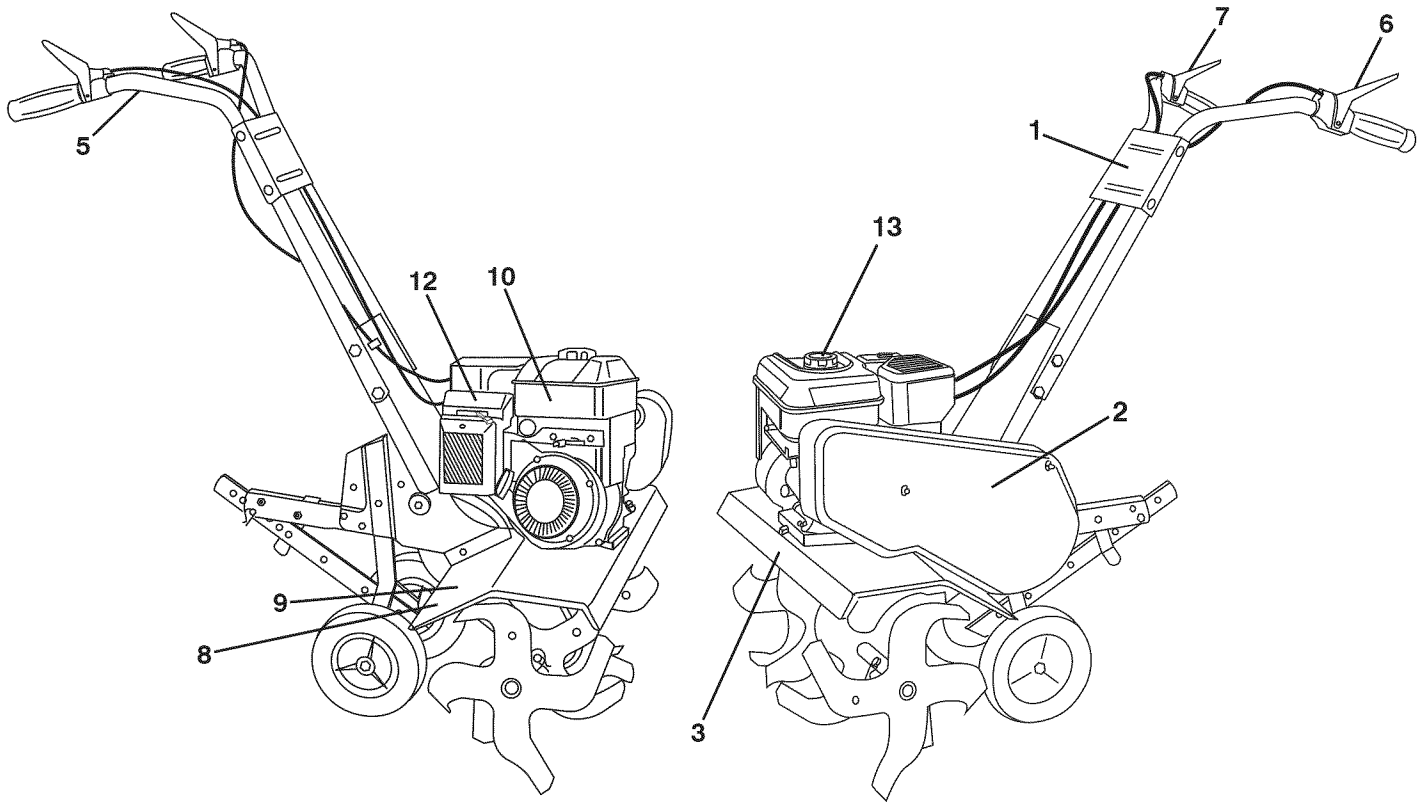

KEY NO.	PART NO.	DESCRIPTION
1	440613	Decal, Logo
2	429196	Decal, Logo
3	439989	Decal, Logo
5	110614	Decal, Hand Placement
6	158700	Decal, Control Forward
7	158701	Decal, Control Reverse
8	120076X	Decal, Warning, Rotating Tines
9	422972	Decal, Tine Shield
10	409143	Decal, Tank
12	432278	Decal, Air Cleaner
13	423830	Decal, Ethanol E85 Warning
--	447254	Manual, Owner's (English/French)



Consumer Wheeled Products – Limited Warranty

Husqvarna warrants to the original retail purchaser that this Husqvarna® product is **free from defects in material or workmanship** under normal use and maintenance from the date of retail purchase for the applicable Warranty Period shown on Exhibit A. Certain components (e.g., engines and transmissions) are excluded from coverage, and other limitations apply, as described in this document. Husqvarna will repair or replace at its discretion, any defective product or part covered by the Limited Warranty, free of charge at any authorized Husqvarna Servicing Dealer/Center using original OEM Husqvarna replacement parts, subject to the limitations and exclusions described below. Husqvarna does not offer an over-the-counter exchange program.

THIS LIMITED WARRANTY IS THE SOLE EXPRESS WARRANTY PROVIDED BY HUSQVARNA. ANY WARRANTY THAT MAY BE IMPLIED BY LAW (INCLUDING ANY IMPLIED WARRANTY OF FITNESS FOR A PARTICULAR PURPOSE OR USE AND IMPLIED WARRANTY OF MERCHANTABILITY) IS LIMITED TO THE DURATION OF THE APPLICABLE WARRANTY PERIOD UNDER THIS LIMITED WARRANTY. THIS LIMITED WARRANTY MAY BE MODIFIED ONLY BY HUSQVARNA. SOME STATES DO NOT ALLOW LIMITATIONS ON HOW LONG AN IMPLIED WARRANTY LASTS, SO THE ABOVE LIMITATIONS MAY NOT APPLY TO YOU. THIS LIMITED WARRANTY GIVES YOU SPECIFIC LEGAL RIGHTS, AND YOU MAY ALSO HAVE OTHER RIGHTS WHICH VARY FROM STATE TO STATE. THIS WARRANTY IS GIVEN **ONLY** BY HUSQVARNA. THE ABOVE REMEDIES ARE THE EXCLUSIVE REMEDIES FOR ANY BREACH OF THIS LIMITED WARRANTY. HUSQVARNA AND ITS AFFILIATED COMPANIES SHALL NOT BE LIABLE FOR ANY SPECIAL, INCIDENTAL OR CONSEQUENTIAL DAMAGE, INCLUDING LOST PROFITS RESULTING FROM ANY SUCH BREACH, AND ALL SUCH DAMAGES ARE HEREBY DISCLAIMED. SOME STATES DO NOT ALLOW THE EXCLUSION OR LIMITATION OF INCIDENTAL OR CONSEQUENTIAL DAMAGES, SO THE ABOVE LIMITATIONS MAY NOT APPLY TO YOU.

LIMITATIONS AND EXCLUSIONS

1. **Engines, Transmissions and certain other components are NOT covered.** This Limited Warranty does not cover any of the following:

(a) *Engines and Attachments.* Except where otherwise indicated on Exhibit A, all Engines and Attachments are not covered by this warranty. In most cases, these items are NOT manufactured by Husqvarna in which case they may be covered separately by their respective manufacturer's warranties if one is provided and included with the product at the time of purchase. All such claims must be submitted and sent to the appropriate manufacturer or as otherwise directed in those separate warranties. Husqvarna is not authorized to handle warranty adjustments or repairs on engines manufactured by Briggs & Stratton, Honda, Kawasaki, or Kohler (exception – models equipped with LCT engines). Husqvarna does not assume any warranty obligation of the other manufacturer's engines.

(b) *Transmissions.* Except where otherwise indicated on Exhibit A, Transmission / Transaxle (including Drive Systems) are not covered by this warranty. In most cases, these items are NOT manufactured by Husqvarna in which case they may be covered separately by their respective manufacturer's warranties if one is provided and included with the product at the time of purchase. The following transmission / transaxle manufacturers, Dana, Hydro-Gear, Tuff-Torq provide a warranty for the transmission / transaxle to the ultimate purchaser or to Husqvarna. Husqvarna will assign the transmission / transaxle manufacturer's warranty or any rights thereof to the original purchaser of the unit. To obtain transmission / transaxle warranty service, first contact the retailer who you purchased the unit from. Should you require assistance or have any questions concerning transmission / transaxle warranty coverage, contact Husqvarna directly at our website www.husqvarna.com or call 800-487-5951 for an authorized Husqvarna service provider. All such claims must be submitted and sent to the appropriate manufacturer or as otherwise directed in those separate warranties. Husqvarna is not authorized to handle warranty adjustments or repairs on transmissions or transaxles. Husqvarna does not assume any warranty obligation of the above listed manufacturers (for exceptions – see Exhibit A).

(c) *Expendable Parts.* This Limited Warranty does not cover general maintenance parts and items ("Expendable Parts"), including without limitation spark plugs, bulbs, filters, lubricants, starter cords, belts, blades, and blade adapters.

(d) *Emissions Control Components.* This Limited Warranty does not cover Emissions control equipment and components to the extent regulated by the U.S. Environmental Protection Agency or similar state agencies. Such equipment and components are covered by a separate emission control warranty statement supplied with your new product. Please consult this separate warranty statement for details.

2. **Any COMMERCIAL, INSTITUTIONAL, AGRICULTURAL, INDUSTRIAL, INCOME PRODUCING, or RENTAL use will result in either No Warranty or a Shortened Warranty Period** Depending on the product; there is either NO WARRANTY or a reduced warranty if the product is used for commercial, institutional, agricultural, industrial, income producing, or rental purposes. Please refer to Exhibit A.

3. **Owner's (Your) Responsibilities.** To preserve your rights under this Limited Warranty, you must demonstrate reasonable care and use of the product, including, following the preventative maintenance, storage, fuel and oil usages as prescribed in the enclosed operator's manual. For example, the following items are the Owner's responsibility and are **not** covered by this Limited Warranty:

- a. Set-up and pre-delivery service, and engine tune-ups.
- b. Adjustments after the first (30) thirty days of purchase and beyond, such as throttle cable, belt guides adjustments.

- c. Preventative maintenance as outlined in the operator's manual.

In addition, you must cease using the product immediately upon any failure or damage. The product should be taken to an authorized Husqvarna servicing dealer prior to any further use.

4. **Damages resulting from normal aging, wear and tear or neglect are NOT covered.** The Limited Warranty does not cover damage other than that resulting from defects in material or workmanship. The following are NOT considered defects in material or workmanship, and therefore are NOT covered.

- (a) Abrasion to mower decks;
- (b) Tires damaged by external punctures;
- (c) Natural discoloration of materials due to ultraviolet light;
- (d) Damage to cutting equipment by way of contact with, rocks, or other non-approved materials and/or structures;

In addition, this Limited Warranty does not cover damages, malfunctions or failures resulting from abuse or neglect of the product related to or including any of the following:

- (e) Failure to provide or perform required maintenance services as prescribed in the operator's manual;
- (f) Abuse, misuse, neglect, modifications, alterations, normal wear, improper servicing, use of unauthorized attachments, Lack of lubrication or engine failure, due to the use of oils that do not meet Engine manufacturer's specifications;
- (g) Use of gasohol, containing methanol (wood alcohol). Gasohol which contains a maximum 10% ethanol (grain alcohol) or 15% MTBE (methyl/tertiary/butyl/ether) is approved;
- (h) Use of ether or any starting fluids;
- (i) Pressure cleaning or steam cleaning the product;
- (j) Use of spark plugs other than those meeting emission performance requirements listed in the operator's manual;
- (k) Tampering with engine speed governor or emission components, or running engines above specified and recommended engine speeds as listed in your operator's manual;
- (l) Operation of the unit with improperly installed/removed or modified cutting shields, guards, or safety devices;
- (m) Any removed/damaged air filter, excessive dirt, abrasives, salt water, moisture, corrosion, rust, varnish, stale fuel, or any adverse reaction due to incorrect storage procedures;
- (n) Failures due to improper set up, pre-delivery service or repair service by anyone other than an authorized Husqvarna servicing dealer during the warranty period;
- (o) Dirt contaminated grease or oil, use of incorrect type of greases or oils, failure to comply with recommended greasing intervals, water or moisture damage, and/or improper storage;
- (p) Sprayers pumping or spraying caustic or flammable materials, lack of or broken strainers; or
- (q) Continued use of product, after initial operational problem or failure occurs.

HOW TO OBTAIN SERVICE

5. **Authorized Husqvarna Servicing Dealer/Center.** In order to obtain warranty coverage it is your responsibility (at your expense) to deliver or ship your Husqvarna unit to an authorized Husqvarna Servicing Dealer/Center and arrange for pick-up or return of your unit after the repairs have been made. If you do not know the location of your nearest authorized Husqvarna Servicing Dealer, call Husqvarna, at 1-800-487-5951 during the hours of 8:00 AM to 8:00 PM Eastern Standard Time, or visit www.husqvarna.com. Should you require assistance or have questions concerning this Limited Warranty, you may contact us at 800-487-5951 during the hours of 8:00 AM to 8:00 PM Eastern Standard Time or contact us through the web at www.husqvarna.com.

6. **Documentation Required.** You must maintain and present Proof of purchase (including date, product model and, if applicable, engine serial number) to an authorized Husqvarna Servicing Dealer for warranty service under this Limited Warranty. Proof of purchase rests solely with the owner-customer. Husqvarna encourages you to register your product online at www.usa.husqvarna.com to help ensure, among other things, that you can be notified of important product information. However, registering your product is not a condition of warranty service.

Husqvarna Consumer Outdoor Products N.A., Inc.; Husqvarna Professional Products, Inc.

9335 Harris Corners Parkway Charlotte, NC 28269

575 49 43-01 R3 2010

Consumer Wheeled Warranty Chart 2010

Exhibit A

Product/Component	<i>Consumer</i> (personal, household use only)	<i>Commercial</i> (any commercial, professional, institutional, agricultural, or income producing use, other than Rental Use)	<i>Rental</i> (any rental usage)
<i>Riding Lawn Tractors:</i>			
Frame, Chassis, Front Axle	5 Years	NO WARRANTY	NO WARRANTY
Engine*	*	*	*
Transmission (if made by Husqvarna/Peerless)	3 Years	NO WARRANTY	NO WARRANTY
Transmission (if third party)**	**	**	**
Battery	1 Year Pro-rated	NO WARRANTY	NO WARRANTY
Other Non-Expendable Components	3 Years	NO WARRANTY	NO WARRANTY
<i>Residential Zero Turn Mowers (RZ Only)</i>			
Engine*	*	*	*
Transmission **	**	NO WARRANTY	NO WARRANTY
Battery	1 Year Pro-rated	NO WARRANTY	NO WARRANTY
Other Non-Expendable Components	3 Years	NO WARRANTY	NO WARRANTY
<i>Residential Zero Turn Mowers (MZ & EZ)</i>			
Engine*	*	*	*
Transmission **	**	**	**
Battery	1 Year Pro-rated	1 Year Pro-rated	NO WARRANTY
Other Non-Expendable Components	3 Years	1 Year	NO WARRANTY
<i>LE475 Edger</i>			
Engine*	*	*	*
Other Non-Expendable Components	2 Years	90 days	90 days
<i>Walk Behind Mowers</i>			
Engine*	*	*	*
Battery	1 Year Pro-rated	NO WARRANTY	NO WARRANTY
Other Non-Expendable Components	2 Years	NO WARRANTY	NO WARRANTY
<i>Snow Throwers</i>			
Engine*	*	*	*
Other Non-Expendable Components	2 Years	90 days	90 days
<i>Tillers</i>			
Engine*	*	*	*
Battery	1 Year Pro-rated	NO WARRANTY	NO WARRANTY
Other Non-Expendable Components	2 Years	NO WARRANTY	NO WARRANTY
Tiller Tines	***	NO WARRANTY	NO WARRANTY
<i>Hovering Trimmers</i>			
Engine*	*	*	*
Other Non-Expendable Components	2 Years	1 Year	90 days
	Consumer	Commercial	Rental

* See Separate Engine Manufacturer's or Manufacturer's warranty

LCT Engines on specific Snow Throwers & Tillers, warranty through Husqvarna.

** See reference 1 (b) of the warranty statement.

RZ - Two (2) Year Consumer warranty, parts & labor, with Hydro-Gear Distributor network.

EZ - One (1) Year Commercial warranty, parts & labor, with Husqvarna.

Two (2) Year Consumer warranty, parts & labor, with Hydro-Gear Distributor network.

MZ - Two (2) Year Commercial warranty, parts & labor, with Hydro-Gear Distributor network.

*** "Limited Lifetime Warranty" on Tiller tines is for the life of the product or 7 (seven) years after the last date of the complete unit's final production, whichever comes first.

Consumer Wheeled Warranty Chart 2010

Exhibit A

Product/Component	<i>Consumer</i> (personal, household use only)	<i>Commercial</i> (any commercial, professional, institutional, agricultural, or income producing use, other than Rental Use)	<i>Rental</i> (any rental usage)
Front Mounted Deck Riders			
Engine*	*	*	*
Transmission	2 Years	NO WARRANTY	NO WARRANTY
Battery	1 Year Pro-rated	NO WARRANTY	NO WARRANTY
Other Non-Expendable Components	2 Years	NO WARRANTY	NO WARRANTY
Cultivators			
Battery	1 Year Pro-rated	NO WARRANTY	NO WARRANTY
Other Non-Expendable Components	2 Years	NO WARRANTY	NO WARRANTY
Pressure Washers			
Model 5525PW:			
Engine*	*	*	*
Pump	2 Years	NO WARRANTY	NO WARRANTY
Other Non-Expendable Components	2 Years	NO WARRANTY	NO WARRANTY
All other Pressure Washers (6027PW, 9032PW, 1340PW)			
Engine*	*	*	*
Pump	2 Years	2 Years	NO WARRANTY
Other Non-Expendable Components	2 Years	2 Years	NO WARRANTY
Generators			
Engine*	*	*	*
Other Non-Expendable Components*	*2 Years (2nd Year Parts Only)	*2 Years-1365GN (2nd Year Parts Only)	NO WARRANTY
Spreaders			
Spreader	1 Year	1 Year	1 Year
Robotic Mowers			
Robotic Mower	2 Years	90 days	90 days
Battery	1 Year	1 Year	1 Year
Parts & Accessories (if purchased)			
Accessories (e.g., grass catcher, bumper guard accessories, etc.)	1 Year	NO WARRANTY	NO WARRANTY
Parts (e.g., belts, blades, etc.)	30 days	NO WARRANTY	NO WARRANTY
Parts & Accessories (if replaced in Warranty Service)			
Replacement parts and/or accessories provided under this Limited Warranty are warranted only for the BALANCE of the warranty period applicable to the part or accessory that was replaced.	See to left	See to left	See to left
	Consumer	Commercial	Rental

* See Separate Engine Manufacturer's or Manufacturer's warranty

LCT Engines on specific Snow Throwers & Tillers, warranty through Husqvarna.

** See reference 1 (b) of the warranty statement.

RZ - Two (2) Year Consumer warranty, parts & labor, with Hydro-Gear Distributor network.

EZ - One (1) Year Commercial warranty, parts & labor, with Husqvarna.

Two (2) Year Consumer warranty, parts & labor, with Hydro-Gear Distributor network.

MZ - Two (2) Year Commercial warranty, parts & labor, with Hydro-Gear Distributor network.

*** "Limited Lifetime Warranty" on Tiller tines is for the life of the product or 7 (seven) years after the last date of the complete unit's final production, whichever comes first.

Get it fixed, at your home or ours!

Just Call:

1-800-4-MY-HOME®

(1-800-469-4663)

24 hours a day, 7 days a week

For the repair of major brand appliances **in your own home...**
no matter who made it, no matter who sold it!

For your nearest **Sears Parts and Service** location,
to bring in products like vacuums, lawn equipment and electronics.

For **Sears Parts & Service**, to order the replacement parts,
accessories and owner's manuals that you need to do-it-yourself.

www.sears.ca

To purchase or inquire about a Sears Maintenance Agreement, call:

1-800-361-6665

9 a.m. – 11 p.m. Mon. – Fri., EST, 9 a.m. – 4 p.m. Sat.

Pour service en français:

1-800-LE-FOYER^{MC}

(1-800-533-6937)

www.sears.ca



02488

® / ™ Trademarks of Sears, Roebuck and Co. used under license by Sears Canada

^{MD} Marque déposée / ^{MC} Marque de commerce de Sears, Roebuck and Co. utilisée en vertu d'une licence de Sears Canada