

SEARS

**OWNER'S
MANUAL**

**MODEL NO.
917.255960**

Caution:
Read and follow
all Safety Rules
and Instructions
Before Operating
This Equipment



CRAFTSMAN[®]

**18.0 HP TWIN CYLINDER
ELECTRIC START
44" MOWER
6 SPEED
GARDEN TRACTOR**

- Assembly
- Operation
- Customer Responsibilities
- Service and Adjustment
- Repair Parts



SAFETY RULES

Safe Operation Practices for Ride-On Mowers



IMPORTANT: THIS CUTTING MACHINE IS CAPABLE OF AMPUTATING HANDS AND FEET AND THROWING OBJECTS. FAILURE TO OBSERVE THE FOLLOWING SAFETY INSTRUCTIONS COULD RESULT IN SERIOUS INJURY OR DEATH.

I. GENERAL OPERATION

- Read, understand, and follow all instructions in the manual and on the machine before starting.
- Only allow responsible adults, who are familiar with the instructions, to operate the machine.
- Clear the area of objects such as rocks, toys, wire, etc., which could be picked up and thrown by the blade.
- Be sure the area is clear of other people before mowing. Stop machine if anyone enters the area.
- Never carry passengers.
- Do not mow in reverse unless absolutely necessary. Always look down and behind before and while backing.
- Be aware of the mower discharge direction and do not point it at anyone. Do not operate the mower without either the entire grass catcher or the guard in place.
- Slow down before turning.
- Never leave a running machine unattended. Always turn off blades, set parking brake, stop engine, and remove keys before dismounting.
- Turn off blades when not mowing.
- Stop engine before removing grass catcher or unclogging chute.
- Mow only in daylight or good artificial light.
- Do not operate the machine while under the influence of alcohol or drugs.
- Watch for traffic when operating near or crossing roadways.
- Use extra care when loading or unloading the machine into a trailer or truck.

II. SLOPE OPERATION

Slopes are a major factor related to loss-of-control and tipover accidents, which can result in severe injury or death. All slopes require extra caution. If you cannot back up the slope or if you feel uneasy on it, do not mow it.

DO:

- Mow up and down slopes, not across.
- Remove obstacles such as rocks, tree limbs, etc.
- Watch for holes, ruts, or bumps. Uneven terrain could overturn the machine. *Tall grass can hide obstacles.*
- Use slow speed. Choose a low gear so that you will not have to stop or shift while on the slope.
- Follow the manufacturer's recommendations for wheel weights or counterweights to improve stability.
- Use extra care with grass catchers or other attachments. These can change the stability of the machine.
- Keep all movement on the slopes *slow* and *gradual*. Do not make sudden changes in speed or direction.
- Avoid starting or stopping on a slope. If tires lose traction, disengage the blades and proceed slowly *straight* down the slope.

DO NOT:

- *Do not* turn on slopes unless necessary, and then, turn slowly and gradually downhill, if possible.
- *Do not* mow near drop-offs, ditches, or embankments. The mower could suddenly turn over if a wheel is over the edge of a cliff or ditch, or if an edge caves in.
- *Do not* mow on wet grass. Reduced traction could cause sliding.
- *Do not* try to stabilize the machine by putting your foot on the ground.
- *Do not* use grass catcher on steep slopes.

III. CHILDREN

Tragic accidents can occur if the operator is not alert to the presence of children. Children are often attracted to the machine and the mowing activity. *Never* assume that children will remain where you last saw them.

- Keep children out of the mowing area and under the watchful care of another responsible adult.
- Be alert and turn machine off if children enter the area.
- Before and when backing, look behind and *down* for small children.
- Never carry children. They may fall off and be seriously injured or interfere with the safe machine operation.
- Never allow children to operate the machine.
- Use extra care when approaching blind corners, shrubs, trees, or other objects that may obscure vision.

IV. SERVICE

- Use extra care in handling gasoline and other fuels. They are flammable and vapors are explosive.
 - Use only an approved container.
 - Never remove gas cap or add fuel with the engine running. Allow engine to cool before refueling. Do not smoke.
 - Never refuel the machine indoors.
 - Never store the machine or fuel container inside where there is an open flame, such as a water heater.
- Never run a machine inside a closed area.
- Keep nuts and bolts, especially blade attachment bolts, tight and keep equipment in good condition.
- Never tamper with safety devices. Check their proper operation regularly.
- Keep machine free of grass, leaves, or other debris build-up. Clean oil or fuel spillage. Allow machine to cool before storing.
- Stop and inspect the equipment if you strike an object. Repair, if necessary, before restarting.
- Never make adjustments or repairs with the engine running.
- Grass catcher components are subject to wear, damage, and deterioration, which could expose moving parts or allow objects to be thrown. Frequently check components and replace with manufacturer's recommended parts, when necessary.
- Mower blades are sharp and can cut. Wrap the blade(s) or wear gloves, and use extra caution when servicing them.
- Check brake operation frequently. Adjust and service as required.



Look for this symbol to point out important safety precautions. It means CAUTION!!! BECOME ALERT!!! YOUR SAFETY IS INVOLVED.



CAUTION: Always disconnect spark plug wire and place wire where it cannot contact spark plug in order to prevent accidental starting when setting up, transporting, adjusting or making repairs.

CONGRATULATIONS on your purchase of a Sears Tractor. It has been designed, engineered and manufactured to give you the best possible dependability and performance.

Should you experience any problem you cannot easily remedy, please contact your nearest Sears Service Center/Department. We have competent, well-trained technicians and the proper tools to service or repair this unit.

Please read and retain this manual. The instructions will enable you to assemble and maintain your unit properly. Always observe the "SAFETY RULES".

MODEL NUMBER	917.255960
SERIAL NUMBER	_____
DATE OF PURCHASE	_____
THE MODEL AND SERIAL NUMBERS WILL BE FOUND ON A PLATE UNDER THE SEAT.	
YOU SHOULD RECORD BOTH SERIAL NUMBER AND DATE OF PURCHASE AND KEEP IN A SAFE PLACE FOR FUTURE REFERENCE.	

MAINTENANCE AGREEMENT

A Sears Maintenance Agreement is available on this product. Contact your nearest Sears store for details.

CUSTOMER RESPONSIBILITIES

- Read and observe the safety rules.
- Follow a regular schedule in maintaining, caring for and using your unit.
- Follow the instructions under "Customer Responsibilities" and "Storage" sections of this owner's manual.

PRODUCT SPECIFICATIONS

HORSEPOWER:	18.0
GASOLINE CAPACITY:	3.5 GALLONS UNLEADED REGULAR
OIL (3.0 PINTS w/o Filter) (3.5 PINTS w/FILTER)	SAE 30 (or 10W-30) WINTER: SAE 5W-30
SPARK PLUG (GAP .025 IN.):	CHAMPION RV15VC
VALVE CLEARANCE:	INTAKE .003-.006 IN. EXHAUST .016-.019 IN.
GROUND SPEED:	(MPH): LO HI 1st .8 1.8 2nd 1.4 3.4 3rd 2.4 5.5 Rev. .9 2.1
TRANSAXLE OIL (4 QUARTS)	NON-DETERGENT SAE 30
TIRE PRESSURE:	FRONT: 14 PSI REAR: 10 PSI
CHARGING SYSTEM:	15 AMPS @ 3600 RPM
BLADE BOLT TORQUE:	30-35 FT. LBS.

WARNING: This unit is equipped with an internal combustion engine and should not be used on or near any unimproved forest-covered, brush-covered or grass-covered land unless the engine's exhaust system is equipped with a spark arrester meeting applicable local or state laws (if any). If a spark arrester is used, it should be maintained in effective working order by the operator.

In the state of California the above is required by law (Section 4442 of the California Public Resources Code). Other states may have similar laws. Federal laws apply on federal lands. A spark arrester for the muffler is available through your nearest Sears Authorized Service Center (See REPAIR PARTS section of this manual).

LIMITED TWO YEAR WARRANTY ON ELECTRIC START RIDING EQUIPMENT

For two (2) years from the date of purchase, if this riding equipment is maintained, lubricated and tuned up according to the instructions in the owner's manual, Sears will repair or replace, free of charge, any parts found to be defective in material or workmanship.

This Warranty does not cover:

- Expendable items which become worn during normal use, such as blades, spark plugs, air cleaners and belts.
- Tire replacement or repair caused by punctures from outside objects, such as nails, thorns, stumps, or glass.
- Repairs necessary because of operator abuse, negligence, improper storage or accident or the failure to maintain the equipment according to the instructions contained in the owner's manual.
- Riding equipment used for commercial or rental purposes.

LIMITED 90 DAY WARRANTY ON BATTERY

For 90 days from date of purchase, if any battery included with this riding equipment proves defective in material or workmanship and our testing determines the battery will not hold a charge, Sears will replace the battery at no charge.

WARRANTY SERVICE IS AVAILABLE BY RETURNING THE RIDING EQUIPMENT TO THE NEAREST SEARS SERVICE CENTER/DEPARTMENT IN THE UNITED STATES.

This Warranty gives you specific legal rights, and you may also have other rights which may vary from state to state.

SEARS, ROEBUCK AND CO., D/731CR-W, SEARS TOWER, CHICAGO, ILLINOIS 60684

TABLE OF CONTENTS

SAFETY RULES	2	MAINTENANCE SCHEDULE	15
PRODUCT SPECIFICATIONS	3	OPERATION	11-14
CUSTOMER RESPONSIBILITIES	3,15-18	SERVICE AND ADJUSTMENT	19-25
WARRANTY	3	STORAGE	26
TABLE OF CONTENTS	4	TROUBLE SHOOTING	27-28
INDEX	4	REPAIR PARTS-TRACTOR	30-53
ASSEMBLY	7-10	SLOPE SHEET	BACK PAGE



INDEX

<p style="text-align: center;">A</p> <p>Adjustment, Attachment Lift Spring 23</p> <p>Adjustments:</p> <p style="padding-left: 20px;">Brake 21</p> <p style="padding-left: 20px;">Carburetor 25</p> <p style="padding-left: 20px;">Clutch Pulley 21</p> <p style="padding-left: 20px;">Gauge Wheels 13</p> <p>Mower:</p> <p style="padding-left: 20px;">Front-To-Back 20</p> <p style="padding-left: 20px;">Side-To-Side 19</p> <p style="padding-left: 20px;">Mower Drive Belt 20</p> <p style="padding-left: 20px;">Throttle Control Cable 25</p> <p>Air Filter, Engine 18</p> <p>Air, Screen, Engine 18</p> <p>Assembly 7-10</p> <p>Attachment Lift Spring:</p> <p style="padding-left: 20px;">Adjustment 23</p> <p style="text-align: center;">B</p> <p>Battery:</p> <p style="padding-left: 20px;">Charging 8</p> <p style="padding-left: 20px;">Cleaning 17</p> <p style="padding-left: 20px;">Installation 10</p> <p style="padding-left: 20px;">Levels 8,17</p> <p style="padding-left: 20px;">Preparation 8</p> <p style="padding-left: 20px;">Starting with Weak Battery 23</p> <p style="padding-left: 20px;">Storage 26</p> <p style="padding-left: 20px;">Terminals 17</p> <p>Belt:</p> <p style="padding-left: 20px;">Motion Drive:</p> <p style="padding-left: 40px;">Removal/Replacement 22</p> <p style="padding-left: 20px;">Mower Blade Drive:</p> <p style="padding-left: 40px;">Removal/Replacement 21</p> <p style="padding-left: 20px;">Mower Drive:</p> <p style="padding-left: 40px;">Removal/Replacement 20</p> <p>Blade:</p> <p style="padding-left: 20px;">Replacement 16</p> <p style="padding-left: 20px;">Sharpening 16</p> <p>Brake Adjustment 21</p> <p style="text-align: center;">C</p> <p>Carburetor, Adjustment 25</p> <p>Controls, Tractor 11</p> <p>Customer Responsibilities 15-18</p> <p>Engine:</p> <p style="padding-left: 20px;">Air Filter 18</p> <p style="padding-left: 20px;">Foam Pre-Cleaner 18</p> <p style="padding-left: 20px;">Air Screen, Engine 18</p> <p style="padding-left: 20px;">Cooling Fins, Engine 18</p> <p style="padding-left: 20px;">Engine Oil 17</p> <p style="padding-left: 20px;">Fuel Filter 18</p> <p style="padding-left: 20px;">Spark Plugs 18</p> <p>Tractor:</p> <p style="padding-left: 20px;">Battery 17</p>	<p style="padding-left: 20px;">Blade 16</p> <p style="padding-left: 20px;">Lubrication Chart 15</p> <p style="padding-left: 20px;">Maintenance Schedule 15</p> <p style="padding-left: 20px;">Tire Care 8,16,22</p> <p style="padding-left: 20px;">Transaxle Oil Level 16</p> <p>Cutting Height, Mower 12</p> <p style="text-align: center;">D</p> <p>Decals 29</p> <p style="text-align: center;">E</p> <p>Engine:</p> <p style="padding-left: 20px;">Adjustments:</p> <p style="padding-left: 40px;">Carburetor 25</p> <p style="padding-left: 40px;">Throttle Control Cable 25</p> <p style="padding-left: 20px;">Air Filter 18</p> <p style="padding-left: 20px;">Air Screen 18</p> <p style="padding-left: 20px;">Cooling Fins 18</p> <p style="padding-left: 20px;">Oil Change 17</p> <p style="padding-left: 20px;">Oil Level 13,17</p> <p style="padding-left: 20px;">Oil Type 17</p> <p style="padding-left: 20px;">Preparation 13</p> <p style="padding-left: 20px;">Starting 14</p> <p style="padding-left: 20px;">Storage 26</p> <p style="text-align: center;">F</p> <p>Filter:</p> <p style="padding-left: 20px;">Air Cleaner 18</p> <p style="padding-left: 20px;">Fuel 18</p> <p style="padding-left: 20px;">OIL 18</p> <p>Fuel:</p> <p style="padding-left: 20px;">Storage 26</p> <p style="padding-left: 20px;">Type 14</p> <p>Fuse 23</p> <p style="text-align: center;">H</p> <p>Headlights 23</p> <p>Hood Removal 24</p> <p style="text-align: center;">L</p> <p>Leveling Mower Deck 19-20</p> <p>Lubrication Chart 15</p> <p style="text-align: center;">M</p> <p>Maintenance Schedule 15</p> <p>Mower:</p> <p style="padding-left: 20px;">Adjustment:</p> <p style="padding-left: 40px;">Front-To-Back 20</p> <p style="padding-left: 40px;">Side-To-Side 19</p> <p style="padding-left: 20px;">Blade Replacement 16</p> <p style="padding-left: 20px;">Blade Sharpening 16</p> <p style="padding-left: 20px;">Cutting Height 12</p> <p style="padding-left: 20px;">Installation 9</p> <p style="padding-left: 20px;">Operation 13</p>	<p style="padding-left: 20px;">Removal 19</p> <p>Mowing Tips 14</p> <p>Muffler 18</p> <p style="padding-left: 20px;">Spark Arrester 3</p> <p style="text-align: center;">O</p> <p>Oil:</p> <p style="padding-left: 20px;">Cold Weather Conditions 13,17</p> <p style="padding-left: 20px;">Engine 17</p> <p style="padding-left: 20px;">Transaxle 16</p> <p>Operating Mower 13</p> <p>Operation 11-14</p> <p style="text-align: center;">P</p> <p>Parking Brake 11,12</p> <p>Parts Bag 6</p> <p>Product Specifications 3</p> <p style="text-align: center;">S</p> <p>Safety Rules 2</p> <p>Schematic 54</p> <p>Seat 8</p> <p>Service & Adjustments 19-25</p> <p style="padding-left: 20px;">Attachment Lift Spring 23</p> <p style="padding-left: 20px;">Clutch Pulley 21</p> <p style="padding-left: 20px;">Fuse 23</p> <p style="padding-left: 20px;">Mower Adjustment</p> <p style="padding-left: 40px;">Front-To-Back 20</p> <p style="padding-left: 40px;">Side-To-Side 19</p> <p style="padding-left: 20px;">Motion Drive Belt:</p> <p style="padding-left: 40px;">Removal/Replacement 22</p> <p style="padding-left: 20px;">Mower Blade Drive Belt:</p> <p style="padding-left: 40px;">Removal/Replacement 21</p> <p style="padding-left: 20px;">Mower Drive Belt:</p> <p style="padding-left: 40px;">Removal/Replacement 20</p> <p style="padding-left: 20px;">Mower Removal 19</p> <p style="padding-left: 20px;">Tire Care 8,16,22</p> <p>Slope Guide Sheet 55</p> <p>Spark Plugs 18</p> <p>Specifications 3</p> <p>Starting the Engine 14</p> <p>Steering Wheel 7,22</p> <p>Stopping the Tractor 12</p> <p>Storage 26</p> <p style="text-align: center;">T</p> <p>Throttle Control Cable:</p> <p style="padding-left: 20px;">Adjustment 25</p> <p>Tires 8,16,22</p> <p>Troubleshooting 27-28</p> <p style="text-align: center;">W</p> <p>Wheels 29</p> <p>Wiring Schematic 54</p>
--	---	---

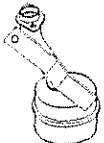
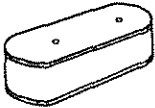
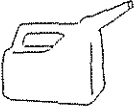

ACCESSORIES AND ATTACHMENTS

These accessories and attachments were available when the unit was purchased. They are also available at most Sears retail outlets, catalog and service centers. Most Sears stores can order these items for you when you provide the model number of your tractor.

ENGINE

SPARK PLUG	MUFFLER	AIR FILTER	GAS CAN	ENGINE OIL	STABILIZER
					

MAINTENANCE

BLADES	BELTS
	

PERFORMANCE

Sears offers a wide variety of attachments that fit your vehicle. Many of these are listed below with brief explanations of how they can help you. This list was current at the time of publication; however, it may change in future years - more attachments may be added, changes may be made in these attachments, or some may no longer be available or fit your model. **Contact your nearest Sears store for the accessories and attachments that are available for your unit.**

Most of these attachments do not require additional hitches or conversion kits (those that do are indicated) and are designed for easy attaching and detaching.

LAWN SWEEPERS let you collect grass clippings and leaves.

LAWN VACS for powerful collection of heavy grass clippings and leaves. Wand attachment to pick up debris in hard-to-reach places.

CARTS make hauling easy. Variety of sizes available.

ROLLER for smoother lawn surface. 36-inch wide, 18-inch diameter water-tight drum holds up to 390 lbs. of weight. Rounded edges prevent harm to turf. Adjustable scraper automatically cleans drum.

SPREADER/SEEDERS make seeding, fertilizing, and weed killing easy. Broadcast spreaders are also useful for granular deicers and sand.

CORING AERATOR takes small plugs out of soil to allow moisture and nutrients to reach grass roots. 36-inch swath. 24 hardened steel coring tips. 150 lb. capacity weight tray.

AERATOR promotes deep root growth for a healthy lawn. Tapered 2.5-inch steel spikes mounted on 10-inch diameter discs puncture holes in soil at close intervals to let moisture soak in.

MULCH RAKE/DETHATCHER loosens soil and flips thatch and matted leaves to lawn surface for easy pickup. Twenty spring tine teeth. Useful to prepare bare areas for seeding. Available for front or rear mounting.

SPRAYERS use 12-volt DC electric motor that connects to the tractor battery or other 12-volt source. Includes booms for automatic spraying when pulling, and hand held wand for spot spraying. Wand has adjustable spray pattern. For applying herbicides, insecticides, fungicides, and liquid fertilizers.

SNOWTHROWER has 40-inch swath. Drum-type auger handles powdery and wet/heavy snow. Mounts easily with simple pin arrangement. Discharge chute adjusts from tractor seat. 6-inch diameter spout discharges snow 10 to 50 feet. Lift controlled at tractor seat. (Use with chains, wheel weights, or rear drawbar weight.)

TIRE CHAINS are heavy duty; closely spaced extra-large cross links give smooth ride, outstanding traction.

WHEEL WEIGHTS for rear wheels provide needed traction for snow removal or dozing heavy materials. (55 lbs. each.)

TRACTOR CAB has heavy duty vinyl fabric over tubular steel frame, ABS plastic top; clear plastic windshield offers 360 degree visibility. Hinged metal doors with catch. Keeps operator warm and dry. Remove vinyl and windshields for use as sun protector in summer. (Catalog only.)

Optional accessories for tractor cab: tinted/tempered solid safety glass windshield with hand operated wiper; 12-volt amber caution light for mounting on cab top. (Catalog only.)

TRACTOR COVER protects tractor from weather. Made of Evolution 3 fabric (water-repellent, extremely breathable, light weight, soft, non-abrasive, pliable in all temperatures, durable, stain/tear/puncture resistant, will not shrink or stretch) (Catalog only.)

TILLER has 8 hp engine to prepare seed beds, cultivate, and compost garden residue. Chain-drive transmission. Six 11-inch diameter one piece heat-treated steel tines. Tills 30-inch path. (Requires sleeve hitch.)

TILLER has 5 hp engine and 36-inch swath to prepare seed beds, cultivate, and compost garden residue. Tiller has its own built-in lift and depth control system and does NOT require a sleeve hitch. Fits any lawn, yard, or garden tractor. Simply hook up to the tractor drawbar and go!

DOZER BLADE removes snow; grades dirt, sand and gravel. 48 inches wide, 17 inches high, clears 44-inch path when angled. Master lift control lever for operator ease. Spring trip for snow removal on uneven pavement; built-in float for blade to follow ground contour. Reversible, replaceable scraper bar. (Use with tire chains, wheel weights or rear drawbar weight.)

FRONT END LOADER system includes double wide rear tires, rear weight box, and hydraulically operated 5.26 cu ft bucket. (Catalog only.)

REAR BLADE is 42 inches wide and operated from driver's seat. Reversible steel blade can be angled at 30 degrees for grading. Reverses for snow plowing. (Requires sleeve hitch.)

SLEEVE CULTIVATOR is 43 inches wide. Prepares ground for seeding, helps weed control. Steel frame holds 5 adjustable sweeps. Adjusts vertically, horizontally. (Requires sleeve hitch.) Optional accessory for cultivator: steel furrow opener for wider openings for potatoes, corn, and other deep-seeded crops.

PLOW turns soil 6 inches deep, cuts 10-inch furrow. Crank adjustment controls depth, 3-position yoke sets width. Heavy steel landslide for straight furrowing. (Requires sleeve hitch.)

DISC HARROW has 2 gangs of 4 steel blades that angle from 10 to 20 degrees, 40 inches wide. Can hook 2 units in tandem. (Requires sleeve hitch.)

WEIGHT BRACKET for drawbar for snow removal applications. Can be mounted on front of tractor for plowing applications. Uses (1) 55 lb weight.

SLEEVE HITCH for use with master lift system. Single pin couples/uncouples.

CONTENTS OF HARDWARE PACK

Parts Bag contents shown full size

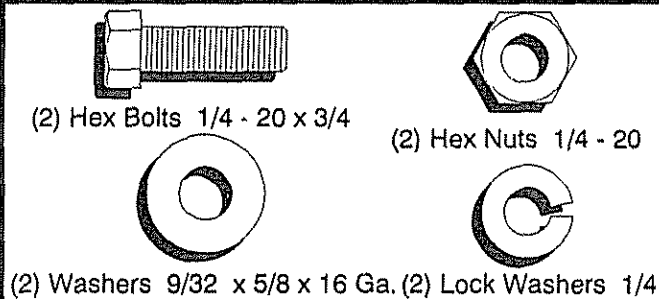
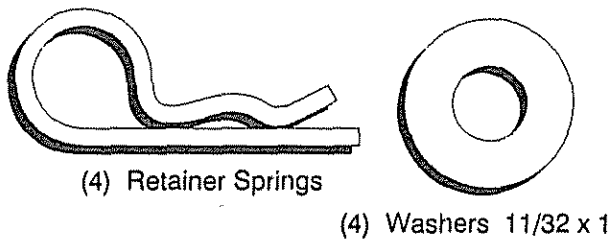
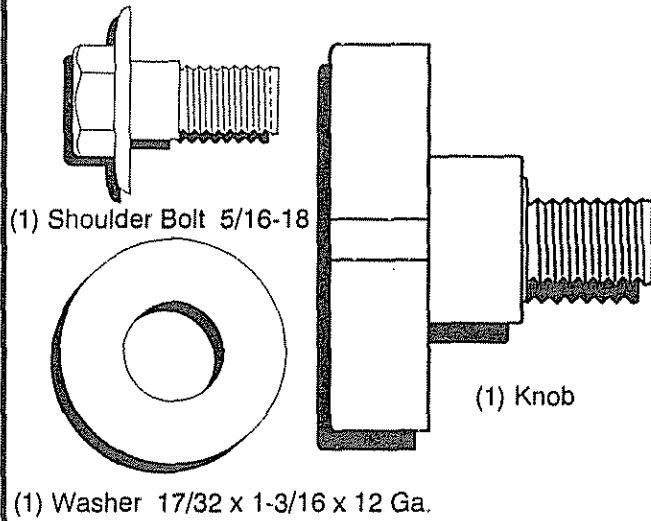

Parts packed separately in carton

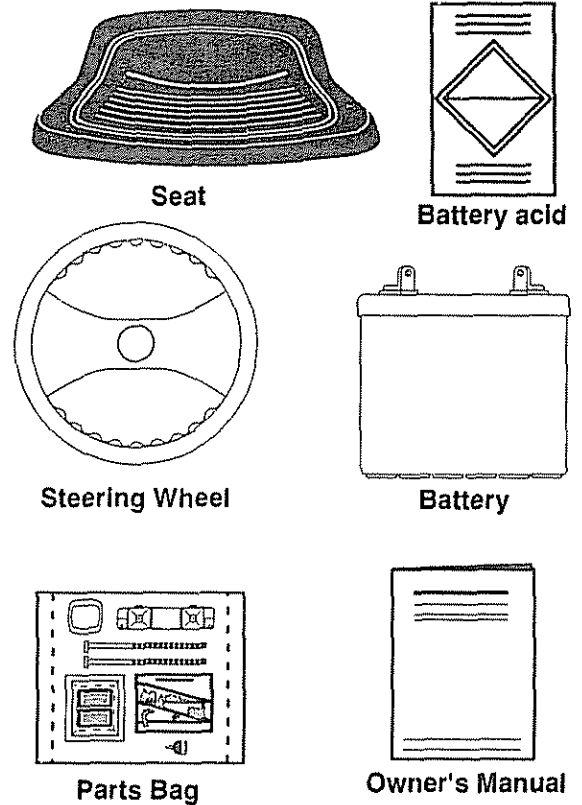

Parts bag contents not shown full size

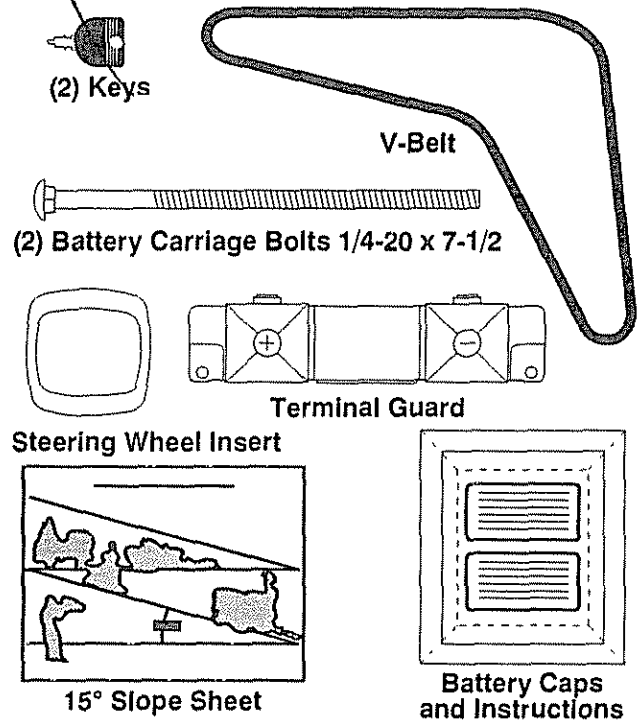

ASSEMBLY

TOOLS REQUIRED FOR ASSEMBLY

A socket wrench set will make assembly easier. Standard wrench sizes are listed.

- (2) 7/16" wrenches
- (1) Tire pressure gauge
- (1) Adjustable wrench
- (1) Utility knife

When right and left hand is mentioned in this manual, it means when you are in the operating position (seated behind the steering wheel).

TO REMOVE UNIT FROM CARTON

UNPACK CARTON

- Remove all accessible loose parts from carton (See page 6).
- Cut along dotted lines on the carton, from top to bottom, all four corners of carton and lay panels flat.
- Remove mower deck from skid.
- Check for any additional loose parts or cartons and remove.

BEFORE ROLLING UNIT OFF SKID

ATTACH STEERING WHEEL (See Fig. 1)

- Remove hex bolt, lock washer and large flat washer from steering shaft.
- Position front wheels of the tractor so they are pointing straight forward.
- Position steering wheel so cross bars are horizontal (left to right) and slide onto adapter.
- Secure steering wheel to steering shaft with hex bolt, lock washer and large flat washer previously removed. Tighten securely.
- Snap insert into center of steering wheel.
- Remove protective plastic from tractor hood and grill.

IMPORTANT: CHECK FOR AND REMOVE ANY STAPLES IN SKID THAT MAY PUNCTURE TIRES WHERE UNIT IS TO ROLL OFF SKID.

(See Fig. 2)

- Raise attachment lift lever to its highest position.
- Place gearshift lever in "NEUTRAL" position.
- Release parking brake by depressing clutch/brake pedal.
- Roll unit backwards off skid.

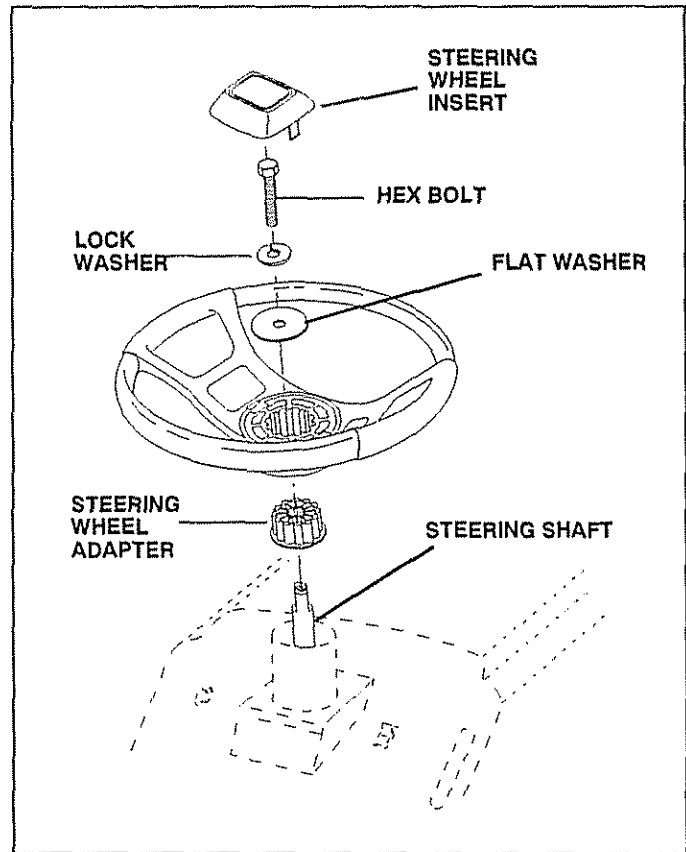

FIG. 1

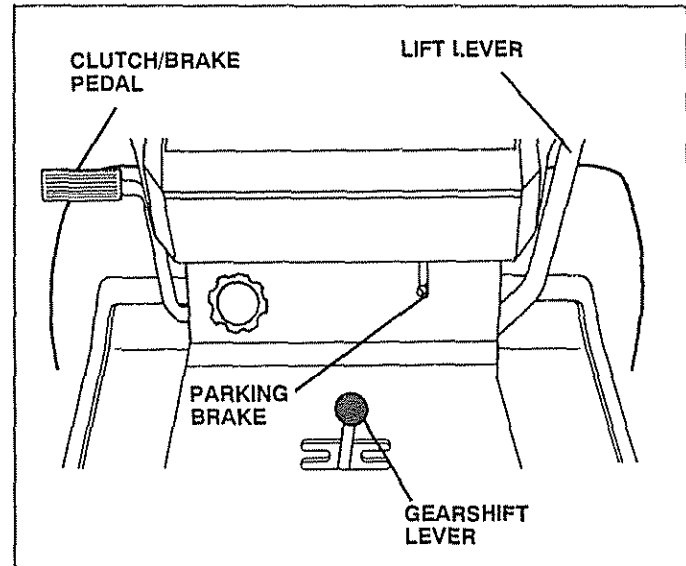

FIG. 2

ASSEMBLY

HOW TO SET UP YOUR TRACTOR PREPARE BATTERY (See Fig. 3)

CAUTION: Wear eye and face shield.

Wash hands or clothing immediately if accidentally in contact with battery acid.

Do not smoke. Fumes from charged battery acid are explosive.

Read the instructions included with the battery vent caps. Always wear gloves, clothing and goggles to protect your hands, skin and eyes.



Your unit has a battery charging system which is sufficient for normal use. However, periodic charging of the battery with an automotive charger will extend its life.

- See instructions packed with vent caps in parts bag.
- Fill battery with acid. Fill each cell until it reaches the bottom of the vent wells. Do not overfill.
- Allow battery to stand and settle for at least thirty minutes. After standing, check the level of acid. If below the vent wells, add more acid until the correct level is reached.

While battery is standing (after adding acid) and later, while battery is being charged, continue with assembly of unit.

IMPORTANT: TO MAXIMIZE THE LIFE OF YOUR BATTERY, IT IS NECESSARY THAT THE BATTERY BE CHARGED BEFORE USE. FAILURE TO CHARGE BATTERY CAN RESULT IN A SHORTENED BATTERY LIFE.

- Charge battery at a rate of 6 amperes for 1 hour. Use a 12 volt battery charger. Observe all safety precautions required for battery charging.
- Check the acid level after the battery is charged. If the acid has fallen below the correct level, add distilled or iron free water.
- Install the vent caps to cover the vent wells. Wash the top of the battery with water to remove any acid, then wipe dry.
- Check battery case for leakage to make sure that no damage has occurred in handling.
- Dispose of excess battery acid. Neutralize acid for disposal by adding it to four inches of water in a five gallon plastic container. Stir with a wooden or plastic paddle while adding baking soda until the addition of more soda causes no more foaming.
- Follow instructions on how to install battery.

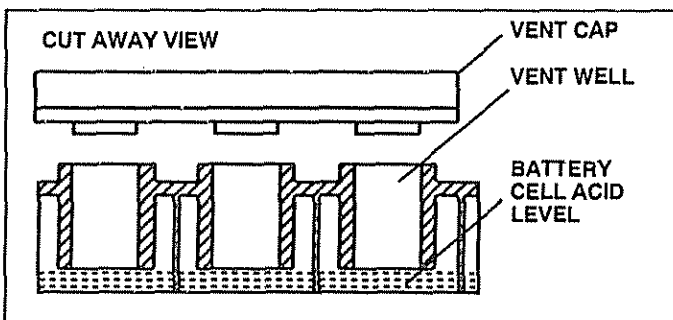

FIG. 3

INSTALL SEAT (See Fig. 4)

Adjust seat before tightening adjustment knob.

- Remove cardboard packing on seat pan.
- Place seat on pan and assemble shoulder bolt.
- Assemble adjustment knob and flat washer loosely. Do not tighten.
- Tighten shoulder bolt securely.
- Lower seat into operating position and sit on seat.
- Slide seat until a comfortable position is reached which allows you to press clutch/brake pedal all the way down.
- Get off seat without moving its adjusted position.
- Raise seat and tighten adjustment knob securely.

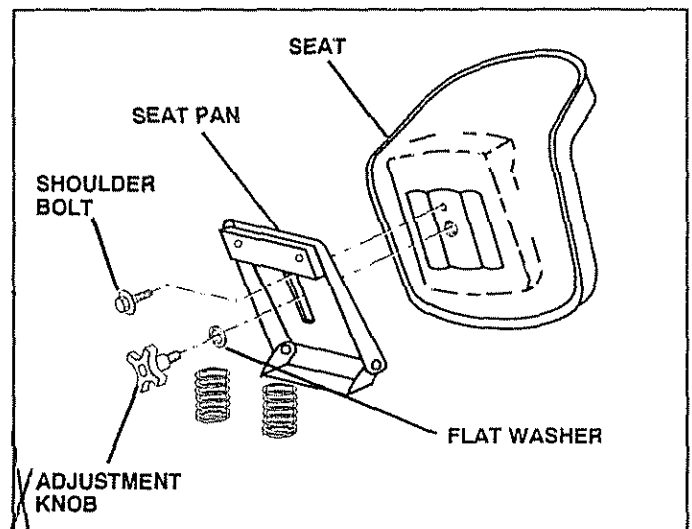

FIG. 4

CHECK TIRE PRESSURE

The tires on your unit were overinflated at the factory for shipping purposes. Correct tire pressure is important for best cutting performance.

- Reduce tire pressure to PSI shown in "PRODUCT SPECIFICATIONS" on page 3 of this manual.

ASSEMBLY

INSTALL MOWER AND DRIVE BELT

Your unit has been shipped with the front mower suspension bracket banded to the frame. Remove bands and pivot bracket downward.

MOWER INSTALLATION (See Figs. 5, 6, 7 and 8)

- Remove banding from suspension arms and gauge wheels. Set gauge wheels aside for later assembly.
- Slide mower under tractor with discharge guard to right side of tractor.
- Slide front suspension brackets into mower brackets. Retain with release pins. Turn height adjustment knob counterclockwise until it stops. Lower mower linkage with attachment lift lever.
- Slide studs through lift links on both sides of tractor. Retain with washers and retainer springs.
- Place the suspension arms on brackets on both sides of frame. Retain with washers and retainer springs.
- Place suspension arms in rear suspension brackets. Retain with release pins.
- Turn height adjustment knob clockwise to remove slack from mower suspension.
- Insert gauge wheel bar into bracket (See Fig. 7). Retain with clevis pins and retainer springs.

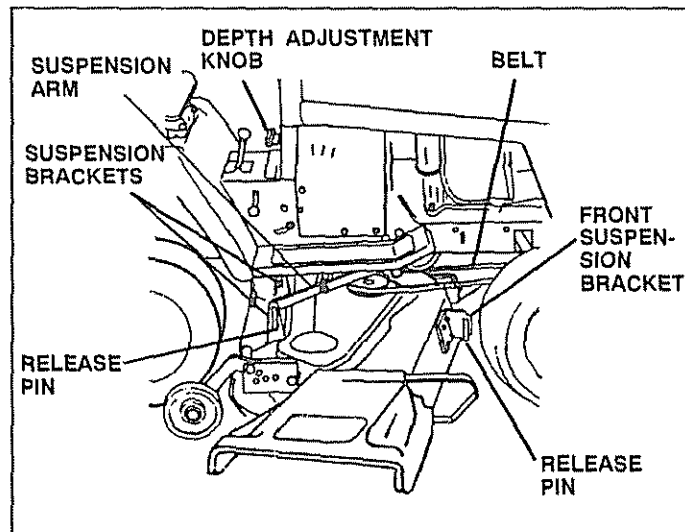

FIG. 5

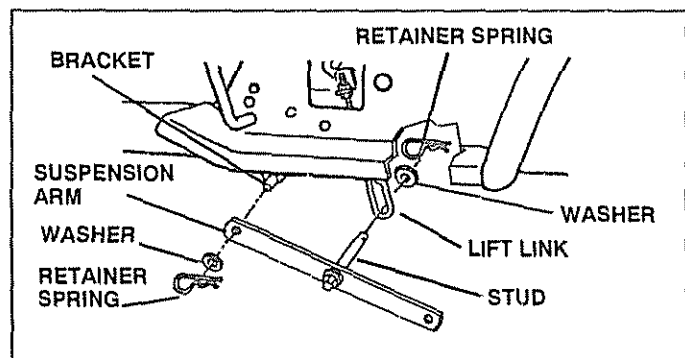

FIG. 6

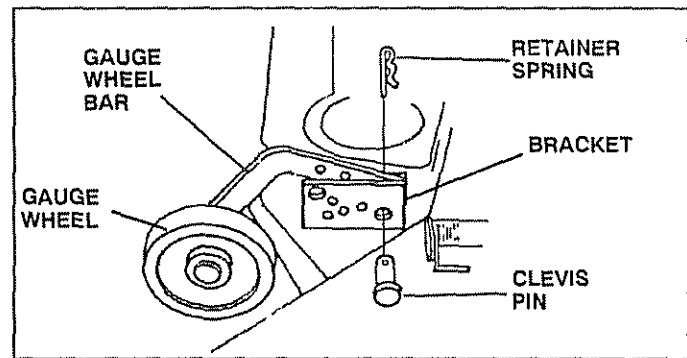

FIG. 7

DRIVE BELT INSTALLATION (See Figs. 8 and 9)

- Remove hood and grill (See "TO REMOVE HOOD AND GRILL ASSEMBLY" in the Service and Adjustments sections of this manual).
- Roll mower drive belt over primary mandrel.
- Roll mower drive belt forward over front mower suspension bracket.
- Place mower drive belt over clutch pulley on engine and under idler pulley and tension pulley.

NOTE: Pull tension pulley lever forward for belt clearance. Make sure narrow "V" side of belt is engaged with each pulley, and push tension pulley lever back to operating position.

- Replace hood and grill assembly.

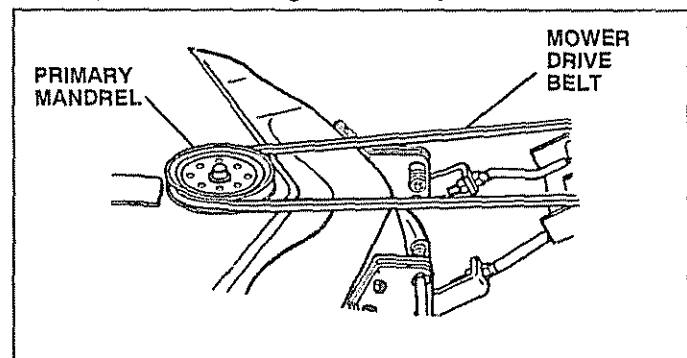

FIG. 8

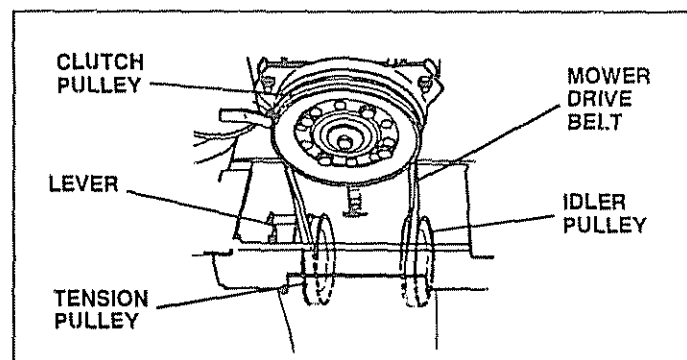

FIG. 9

CHECK DECK LEVELNESS

For best cutting results, mower housing should be properly leveled. See "TO LEVEL MOWER HOUSING" in the Service and Adjustments section of his manual

ASSEMBLY

CHECK FOR PROPER POSITION OF ALL BELTS

See the figures that are shown for replacing motion, mower drive, and mower blade drive belts in the Service and Adjustments section of this manual. Verify that the belts are routed correctly.

CHECK BRAKE SYSTEM

After you learn how to operate your tractor, check to see that the brake is properly adjusted. See "TO ADJUST BRAKE" in the Service and Adjustments section of this manual.

INSTALL BATTERY (See Figs. 10 and 11)



CAUTION: Do not short battery terminals. Before installing battery, remove metal bracelets, wristwatch bands, rings, etc.

Positive terminal must be connected first to prevent sparking from accidental grounding.

- Raise hood.
- Make sure drain tube is fastened to drain hole in battery tray and battery tray is positioned in hole of battery support.
- Place battery in plastic tray, battery terminals to front of tractor.
- First connect RED battery cable to positive (+) battery terminal with hex bolt, flat washer, lock washer and hex nut as shown. Tighten securely.
- Connect BLACK grounding cable to negative (-) battery terminal with remaining hex bolt, flat washer, lock washer and hex nut. Tighten securely.
- Slide the two battery bolts through the terminal guard and start the wing nuts onto the threads.
- Position terminal guard over the battery as shown, lower bolts into key holes and slide square shafts of bolts into slots of key holes.
- Tighten wing nuts by hand making sure battery bolts remain in slots of the key holes in the battery support.
- Be sure terminal access doors are closed.

Use terminal access doors for:

- Inspection for secure connections (to tighten hardware).
- Inspection for corrosion.
- Testing battery.
- Jumping (if required).
- Periodic charging.

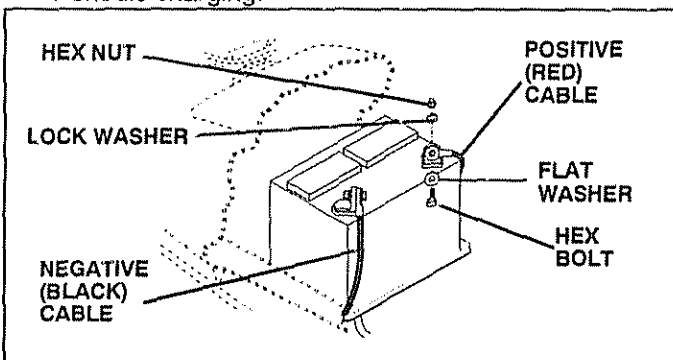

FIG. 10

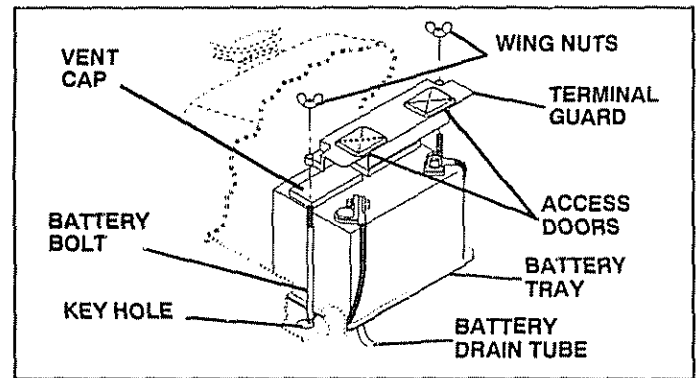

FIG. 11

✓ CHECKLIST

BEFORE YOU OPERATE AND ENJOY YOUR NEW TRACTOR, WE WISH TO ASSURE THAT YOU RECEIVE THE BEST PERFORMANCE AND SATISFACTION FROM THIS QUALITY PRODUCT.

PLEASE REVIEW THE FOLLOWING CHECKLIST:

- ✓ All assembly instructions have been completed.
- ✓ No remaining loose parts in carton.
- ✓ Battery is properly prepared and charged. (Minimum 1 hour at 6 amps).
- ✓ Seat is adjusted comfortably and tightened securely.
- ✓ All tires are properly inflated. (For shipping purposes, the tires were over-inflated at the factory).
- ✓ Be sure mower deck is properly leveled side-to-side/front-to-rear for best cutting results. (Tires must be properly inflated for leveling).
- ✓ Check mower and drive belts. Be sure they are routed properly around pulleys and inside all belt keepers.
- ✓ Check wiring. See that all connections are still secure and wires are properly clamped.

WHILE LEARNING HOW TO USE YOUR TRACTOR, PAY EXTRA ATTENTION TO THE FOLLOWING IMPORTANT ITEMS:

- ✓ Engine oil is at proper level.
- ✓ Fuel tank is filled with fresh, clean, regular unleaded gasoline.
- ✓ Become familiar with all controls-their location and function. Operate them before you start the engine.
- ✓ Be sure brake system is in safe operating condition.

OPERATION

KNOW YOUR TRACTOR

READ THIS OWNER'S MANUAL AND SAFETY RULES BEFORE OPERATING YOUR TRACTOR.

Compare the illustrations with your Tractor to familiarize yourself with the location of various controls and adjustments. Save this manual for future reference.

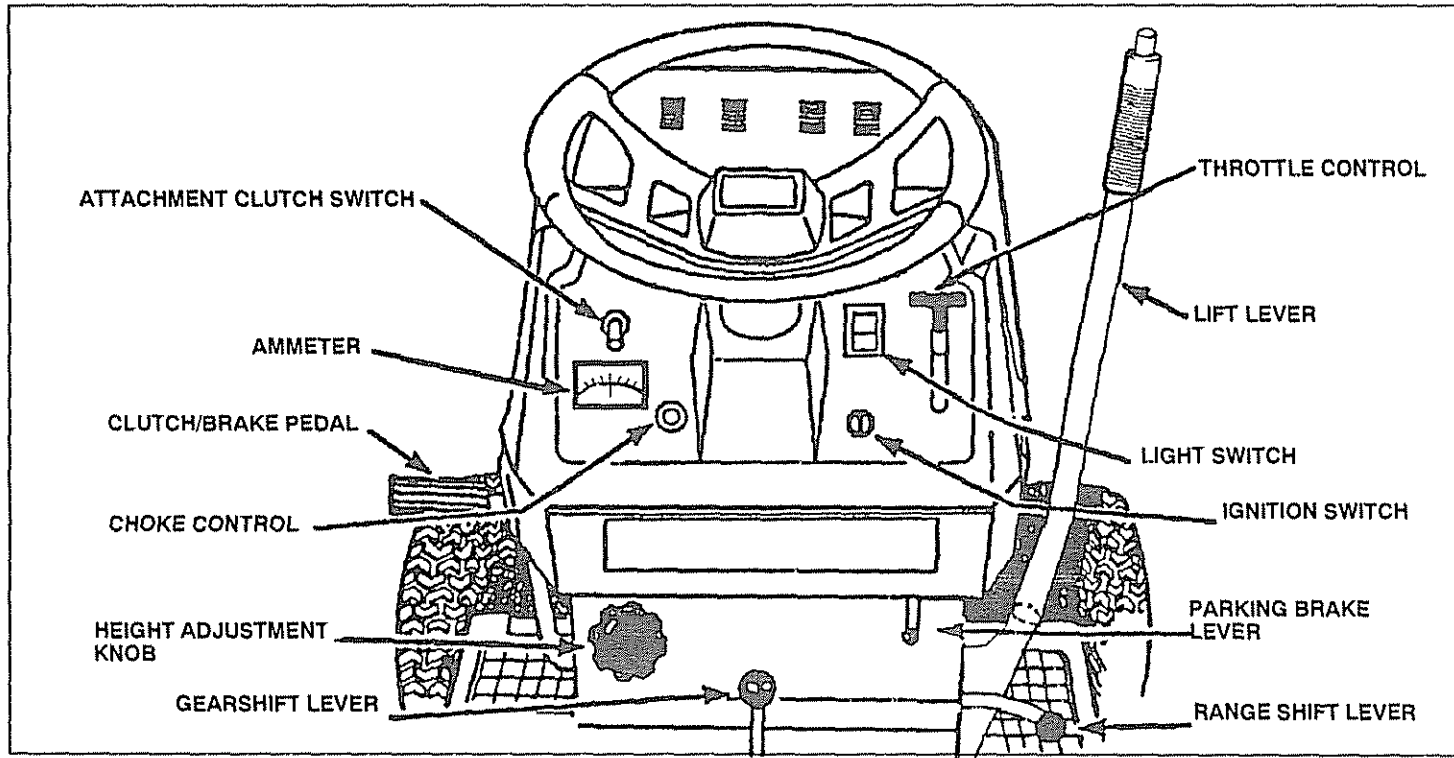

FIG. 12

Sears tractors conform to the safety standards of the American National Standards Institute.

ATTACHMENT CLUTCH SWITCH - Used to engage mower blades or other attachments mounted to your tractor.

LIFT LEVER - Used to raise and lower mower deck or other attachments mounted to your tractor.

CLUTCH/BRAKE PEDAL - Used for declutching and braking the tractor and starting the engine.

GEARSHIFT LEVER - Selects the speed and direction of tractor.

THROTTLE CONTROL - Used to control engine speed.

RANGE SHIFT LEVER - Allows "HI" or "LO" speed for all forward and reverse gears.

IGNITION SWITCH - Used to start and stop the engine.

AMMETER - Indicates battery charging (+) or discharging (-).

LIGHT SWITCH - Turns the headlights on and off.

PARKING BRAKE LEVER - Locks clutch/brake pedal into the brake position.

CHOKE CONTROL - Used when starting a cold engine.

HEIGHT ADJUSTMENT KNOB - Used to adjust the mower height.

OPERATION



The operation of any tractor can result in foreign objects thrown into the eyes, which can result in severe eye damage. Always wear safety glasses or eye shields before starting your tractor and while moving. We recommend Wide Vision Safety Mask for over the spectacles or standard safety glasses.

HOW TO USE YOUR TRACTOR TO SET PARKING BRAKE (See Fig. 13)

- Depress clutch/brake pedal into full "BRAKE" position and hold.
- Place parking brake lever in "ENGAGED" position and release pressure from clutch/brake pedal. Pedal should remain in "BRAKE" position. Make sure parking brake will hold vehicle secure.

STOPPING (See Fig. 13)

MOWER BLADES -

- Move attachment clutch switch to "DISENGAGED" position.

GROUND DRIVE -

- Depress clutch/brake pedal into full "BRAKE" position.
- Move gearshift lever to "NEUTRAL" position.

ENGINE -

- Move Throttle Control to "SLOW" position.
- Turn ignition key to "OFF" position and remove key. Always remove key when leaving vehicle to prevent unauthorized use.
- Never use choke to stop engine.

NOTE: Under certain conditions when unit is standing idle with the engine running, hot engine exhaust gasses may cause "browning" of grass. To eliminate this possibility, always stop engine when stopping unit on grass areas.



CAUTION: Always stop unit completely, as described above, before leaving the operator's position; to empty grass catcher, etc.

TO USE CHOKE CONTROL (See Fig. 13)

Use choke control whenever you are starting a cold engine. Do not use to start a warm engine.

- To engage choke control, pull knob out. Slowly push knob into disengage.

TO USE THROTTLE CONTROL (See Fig. 13)

Always operate engine at full throttle.

- Operating engine at less than full throttle reduces the battery charging rate and the engine cooling air flow.
- Full throttle offers the best mower performance.

TO MOVE FORWARD AND BACKWARD (See Fig. 13)

The direction and speed of movement is controlled by the gearshift lever.

- Start tractor with clutch/brake pedal depressed and gearshift lever in "NEUTRAL" position.

- Move gearshift and range shift levers to desired position.

- Slowly release clutch/brake pedal to start movement.
- IMPORTANT:** BRING TRACTOR TO A COMPLETE STOP BEFORE SHIFTING OR CHANGING GEARS. FAILURE TO DO SO WILL SHORTEN THE USEFUL LIFE OF YOUR TRANSAXLE.

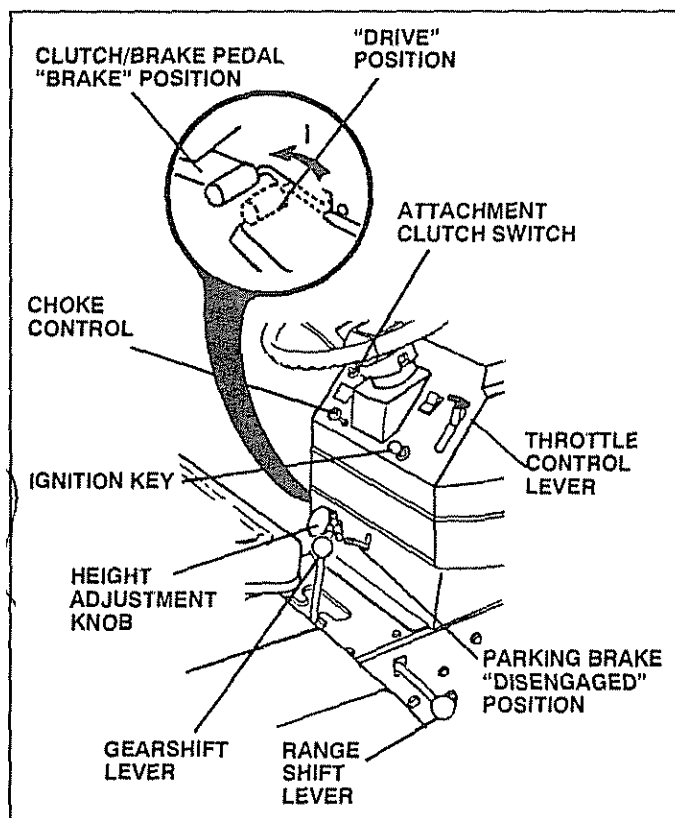

FIG. 13

TO ADJUST MOWER CUTTING HEIGHT (See Fig. 13)

The cutting height is controlled by turning the height adjustment knob in desired direction.

- Turn knob clockwise to raise cutting height.
- Turn knob counterclockwise to lower cutting height.

The cutting height range is approximately 1-1/4" to 3-3/4". The heights are measured from the ground to the blade tip with the engine not running. These heights are approximate and may vary depending upon soil conditions, height of grass and types of grass being mowed.

- The average lawn should be cut approximately 2-1/2 inches during the cool season and over 3 inches during hot months. For healthier and better looking lawns, mow often and after moderate growth.
- For best cutting performance, grass over 6 inches in height should be mowed twice. Make the first cut relatively high; the second to desired height.

OPERATION

TO ADJUST GAUGE WHEELS (See Fig. 14)

- Adjust mower to desired cutting height.
- Lower mower with lift control. Remove rear retainer spring and clevis pin which secure each gauge wheel.
- Lower gauge wheels to ground. Raise gauge wheels slightly to align holes in bracket and gauge wheel bar and insert clevis pins. Gauge wheels should be slightly off the ground.
- Replace retainer springs into clevis pins.

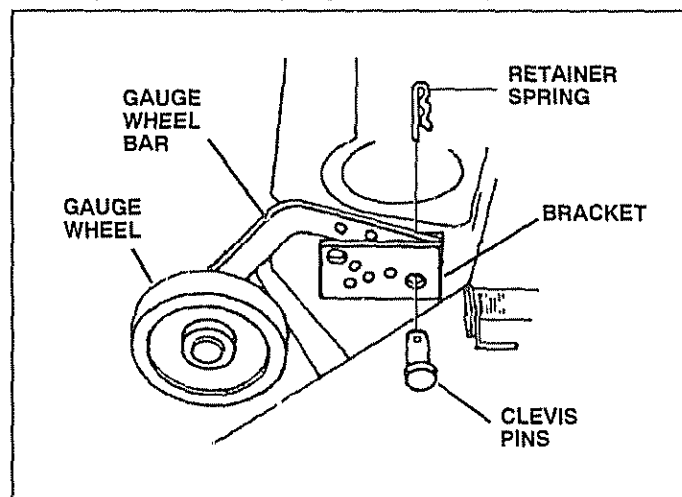

FIG. 14

TO OPERATE MOWER (See Figs. 12 and 13)

Your unit is equipped with an operator presence sensing switch. Any attempt by the operator to leave the seat with the engine running and the mower clutch engaged will shut off the engine.

- Select desired height of cut, using height adjustment knob.
- Lower mower with lift lever.
- Engage mower by slowly moving mower clutch lever to "ENGAGED" position.
- TO STOP MOWER - Move mower clutch lever to "DISENGAGED" position.



CAUTION: Do not operate the mower without either the entire grass catcher, on mowers so equipped, or the discharge guard in place.

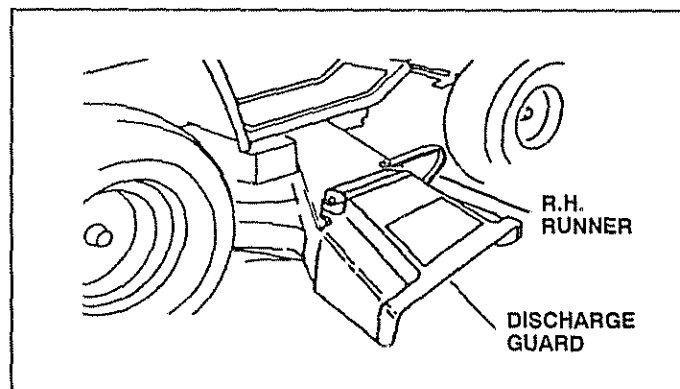

FIG. 15

TO OPERATE ON HILLS



CAUTION: Do not drive up or down hills with slopes greater than 15° and do not drive across any slope.

- Choose the slowest speed before starting up or down hills.
- Avoid stopping or changing speed on hills.
- If slowing is necessary, move throttle control lever to slower position.
- If stopping is absolutely necessary, push clutch/brake pedal quickly to brake position and engage parking brake.
- Move gearshift lever to "NEUTRAL" position.
- To restart movement, move gearshift lever to 1st gear and range shift lever to "LO" position. Be sure you have allowed room for unit to roll slightly as you restart movement.
- Slowly release parking brake and clutch/brake pedal.
- Make all turns slowly.

TO TRANSPORT

- Raise attachment lift control to highest position.
- When pushing or towing your unit, be sure gearshift lever is in "NEUTRAL" position.
- Do not push unit at more than five (5) MPH.

BEFORE STARTING THE ENGINE

CHECK ENGINE OIL LEVEL (See Fig. 16)

- The engine in your unit has been shipped, from the factory, already filled with summer weight oil.
- Check engine oil with unit on level ground.
- Remove dipstick and wipe clean, replace, wait for a few seconds, remove and read oil level. If necessary, add oil until "FULL" mark on dipstick is reached. Do not overfill.
- For cold weather operation you should change oil for easier starting (see "OIL VISCOSITY CHART" in the Customer Responsibilities section of this manual).
- To change engine oil, see the Customer Responsibilities section in this manual.

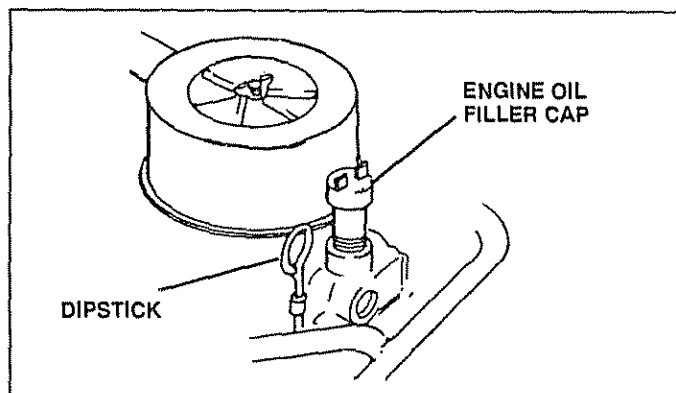

FIG. 16

OPERATION

ADD GASOLINE

- Fill fuel tank. Use fresh, clean, regular unleaded gasoline. (Use of leaded gasoline will increase carbon and lead oxide deposits and reduce valve life).

IMPORTANT: WHEN OPERATING IN TEMPERATURES BELOW 32°F(0°C), USE FRESH, CLEAN WINTER GRADE GASOLINE TO HELP INSURE GOOD COLD WEATHER STARTING.

WARNING: Experience indicates that alcohol blended fuels (called gasohol or using ethanol or methanol) can attract moisture which leads to separation and formation of acids during storage. Acidic gas can damage the fuel system of an engine while in storage. To avoid engine problems, the fuel system should be emptied before storage of 30 days or longer. Drain the gas tank, start the engine and let it run until the fuel lines and carburetor are empty. Use fresh fuel next season. See Storage Instructions for additional information. Never use engine or carburetor cleaner products in the fuel tank or permanent damage may occur.



CAUTION: Fill to bottom of gas tank filler neck. Do not overfill. Wipe off any spilled oil or fuel. Do not store, spill or use gasoline near an open flame.

TO START ENGINE (See Fig.13)

When starting engine for the first time or if engine has run out of fuel, it will take extra cranking time to move fuel from the tank to the engine.

- Depress the clutch/brake pedal and set the parking brake.
- Place gearshift lever in "NEUTRAL" position.
- Move attachment clutch to "DISENGAGED" position.
- Pull choke control out to "CHOKE" position for cold engine start. For warm engine start do not use choke control.
- Move throttle control to midway between "FAST" and "SLOW" positions.
- Turn ignition key clockwise to "START" position and release key as soon as engine starts. Do not run starter continuously for more than fifteen seconds per minute. If engine does not start after several attempts, move throttle control to "FAST" position, wait a few minutes and try again.
- When engine starts, slowly push choke control in.
- Move throttle control to "FAST" position.
- Allow engine to warm up for a few minutes before engaging clutch/brake pedal or attachment clutch switch.

NOTE: If at a high altitude (above 3000 feet) or in cold temperatures (below 32° F), the carburetor fuel mixture may need to be adjusted for best engine performance. See "TO ADJUST CARBURETOR" in the Service and Adjustments section of this manual.



CAUTION: Before driving the tractor, install mower or remove front mower suspension bracket and suspension arms.

MOWING TIPS

- Tire chains cannot be used when the mower housing is attached to unit.
- Mower should be properly leveled for best mowing performance. See "TO LEVEL MOWER HOUSING" in the Service and Adjustments section of this manual.
- Use the runner on the right hand side of mower as a guide. The blade cuts approximately an inch outside the runner (See Fig. 15).
- The left hand side of mower should be used for trimming.
- Drive so that clippings are discharged onto the area that has been cut. Have the cut area to the right of the machine. This will result in a more even distribution of clippings and more uniform cutting.
- When mowing large areas, start by turning to the right so that clippings will discharge away from shrubs, fences, driveways, etc. After one or two rounds, mow in the opposite direction making left hand turns until finished (See Fig. 17).
- If grass is extremely tall, it should be mowed twice to reduce load and possible fire hazard from dried clippings. Make first cut relatively high; the second to the desired height.
- Do not mow grass when it is wet. Wet grass will plug mower and leave undesirable clumps. Allow grass to dry before mowing.
- Always operate engine at full throttle when mowing to assure better mowing performance and proper discharge of material. Regulate ground speed by selecting a low enough gear to give the mower cutting performance as well as the quality of cut desired.
- When operating attachments, select a ground speed that will suit the terrain and give best performance of the attachment being used.

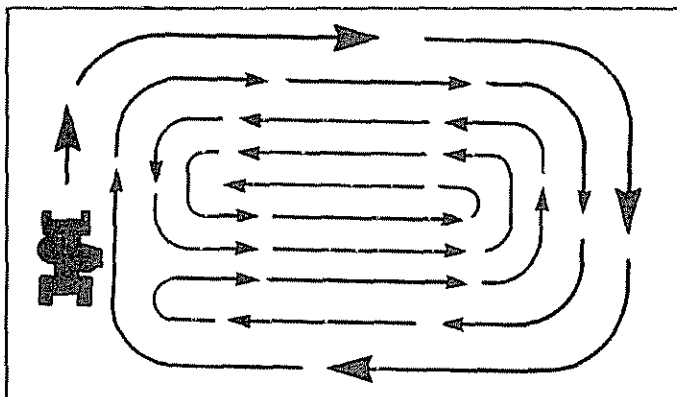

FIG. 17

CUSTOMER RESPONSIBILITIES

MAINTENANCE SCHEDULE FILL IN DATES AS YOU COMPLETE REGULAR SERVICE		SERVICE INTERVALS							SERVICE DATES		
		BEFORE EACH USE	FIRST 2 HOURS	EVERY 8 HOURS	EVERY 25 HOURS	EVERY 50 HOURS	EVERY 100 HOURS	BEFORE SEASON			BEFORE STORAGE
TRACTOR	Check Brake Operation	✓		✓							
	Check Tire Pressure	✓		✓							
	Check for Loose Fasteners	✓						✓			
	Sharpen/Replace Mower Blades				✓ ₄						
	Lubrication Chart				✓			✓			
	Check Battery Level/Recharge				✓						
	Clean Battery and Terminals				✓			✓			
	Check Transmission Cooling				✓						
	Adjust Blade Belt(s) Tension					✓					
	Adjust Motion Drive Belt(s) Tension					✓					
ENGINE	Check Engine Oil Level	✓		✓							
	Change Engine Oil		✓		✓ _{1,2,3}			✓			
	Clean Air Filter				✓ ₂						
	Clean Air Screen				✓ ₂						
	Inspect Muffler/Spark Arrester					✓					
	Replace Oil Filter (If equipped)						✓ _{1,2}				
	Clean Engine Cooling Fins						✓ ₂				
	Replace Spark Plug						✓	✓			
	Replace Air Filter Paper Cartridge						✓ ₂				
	Replace Fuel Filter							✓			

1 - Change more often when operating under a heavy load or in high ambient temperatures
2 - Service more often when operating in dirty or dusty conditions

3 - If equipped with oil filter, change oil every 50 hours
4 - Replace blades more often when mowing in sandy soil

GENERAL RECOMMENDATIONS

The warranty on this vehicle does not cover items that have been subjected to operator abuse or negligence. To receive full value from the warranty, operator must maintain unit as instructed in this manual.

Some adjustments will need to be made periodically to properly maintain your unit.

All adjustments in the Service and Adjustments section of this manual should be checked at least once each season.

- Once a year you should replace the spark plug, clean or replace air filter, and check blades and belts for wear. A new spark plug and clean air filter assure proper air-fuel mixture and help your engine run better and last longer.

BEFORE EACH USE

- Check engine oil level.
- Check brake operation.
- Check tire pressure.
- Check for loose fasteners.

IMPORTANT: DO NOT OIL OR GREASE THE PIVOT POINTS WHICH HAVE SPECIAL NYLON BEARINGS. VISCOUS LUBRICANTS WILL ATTRACT DUST AND DIRT THAT WILL SHORTEN THE LIFE OF THE SELF-LUBRICATING BEARINGS. IF YOU FEEL THEY MUST BE LUBRICATED, USE ONLY A DRY, POWDERED GRAPHITE TYPE LUBRICANT SPARINGLY.

LUBRICATION CHART

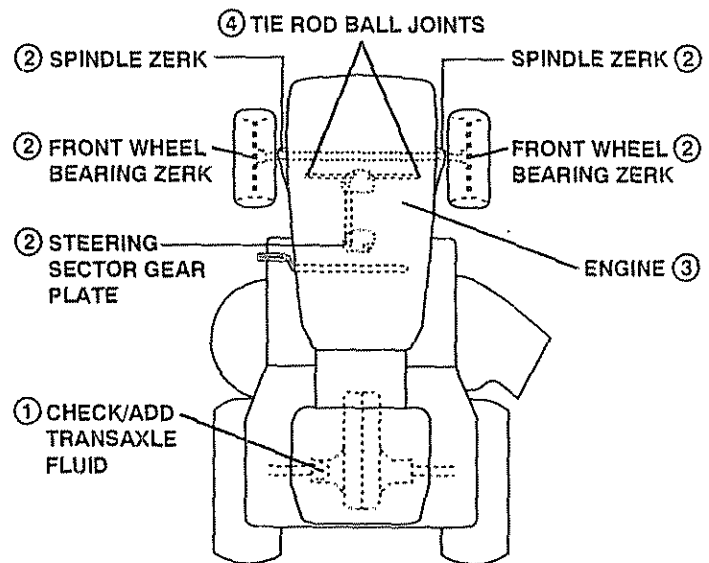

- SAE 30 MOTOR OIL API - SG
- GENERAL PURPOSE GREASE
- REFER TO ENGINE MAINTENANCE SECTION
- SPRAY SILICONE LUBRICANT (MOVE BOOTS TO LUBRICATE)

CUSTOMER RESPONSIBILITIES

TRACTOR

Always observe safety rules when performing any maintenance.

BRAKE OPERATION

If unit requires more than six (6) feet stopping distance at high speed in highest gear, than brake must be adjusted. (See "TO ADJUST BRAKE" in Service and Adjustments section of this manual).

TIRES

- Maintain proper air pressure in all tires (See "PRODUCT SPECIFICATIONS" on page 3 of this manual).
- Keep tires free of gasoline, oil, or insect control chemicals which can harm rubber.
- Avoid stumps, stones, deep ruts, sharp objects and other hazards that may cause tire damage.

BLADE CARE

For best results mower blades must be kept sharp. The blades can be sharpened with a file or on a grinding wheel. We suggest they be sharpened or replaced after every 25 hours of mowing. Check blades more often if mowing in sandy conditions.

- Do not attempt to sharpen blades while they are on the mower.
- Replace bent or damaged blades.

BLADE REMOVAL (See Fig. 18)

- Raise mower to highest position to allow access to blades.
- Remove hex bolt, lock washer and flat washer securing blade.
- Install new or resharpened blade with trailing edge up towards deck as shown.
- Reassemble hex bolt, lock washer and flat washer in exact order as shown.
- Tighten bolt securely (30-35 Ft. Lbs. torque).

IMPORTANT: BLADE BOLT IS GRADE 5 HEAT TREATED.

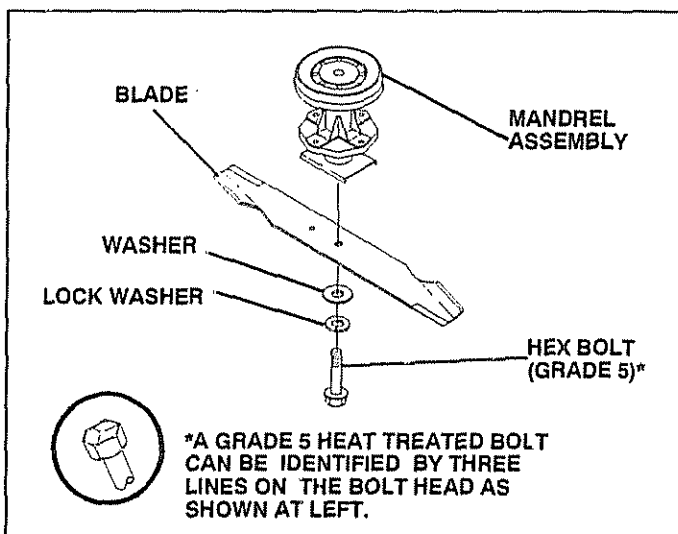

FIG. 18

TO SHARPEN BLADE (See Fig. 19)

Care should be taken to keep the blade balanced. An unbalanced blade will cause excessive vibration and eventual damage to mower and engine.

- The blade can be sharpened with a file or on a grinding wheel. Do not attempt to sharpen while on the mower.
- To check blade balance, drive a nail into a beam or wall. Leave about one inch of the straight nail exposed. Place center hole of blade over the head of the nail. If blade is balanced, it should remain in a horizontal position. If either end of the blade moves downward, sharpen the heavy end until the blade is balanced.

NOTE: Do not use a nail for balancing blade. The lobes of the center hole may appear to be centered, but are not.

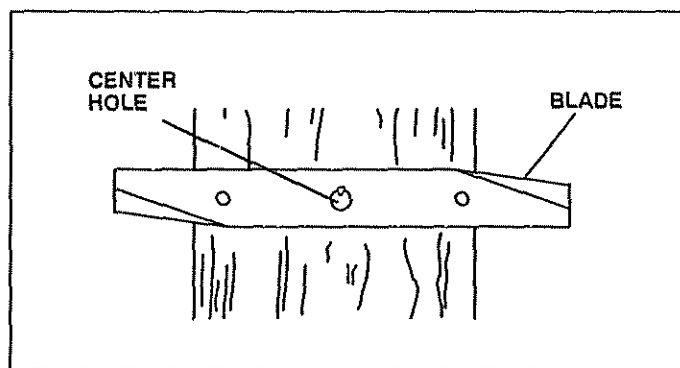

FIG. 19

CHECK TRANSAXLE OIL LEVEL (See Fig. 20)

- Block up rear axle securely or use a tractor jack.
- Remove left rear wheel by removing hub bolts.
- Remove filler plug from transaxle. Oil level must be even with plug threads. If necessary, fill with SAE 30 non-detergent oil (ISO 100). Replace filler plug.
- Reassemble wheel to hub.
- For approximate capacity see "Product Specifications" on page 3 of this manual.

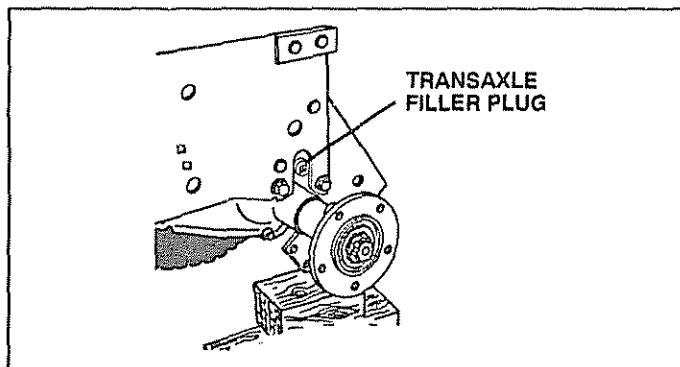

FIG. 20

CUSTOMER RESPONSIBILITIES

BATTERY (See Fig. 21)

Your unit has a battery charging system which is sufficient for normal use. However, periodic charging of the battery with an automotive charger will extend its life.

- Acid solution level in each battery cell should be even with bottoms of vent wells. Add only distilled or iron free water if necessary. Do not overfill.
- Keep battery and terminals clean.
- Keep battery bolts tight.
- Keep vent caps tight and small vent holes in caps open.
- Recharge at 6 amperes for 1 hour.

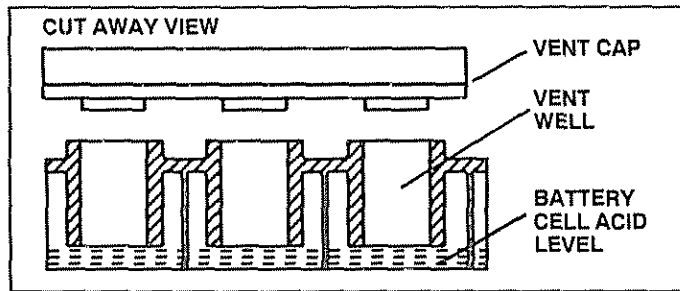

FIG. 21

TO CLEAN BATTERY AND TERMINALS -

Corrosion and dirt on the battery and terminals can cause the battery to "leak" power.

- Remove terminal guard.
- Disconnect BLACK battery cable first then RED battery cable and remove battery from tractor.
- Wash battery with solution of four tablespoons of baking soda to one gallon of water. Be careful not to get the soda solution into the cells.
- Rinse the battery with plain water and dry.
- Clean terminals and battery cable ends with wire brush until bright.
- Coat terminals with grease or petroleum jelly.
- Reinstall battery (See "INSTALL BATTERY" in Assembly section of this manual).

V- BELTS

Check V-Belts for deterioration and wear after 100 hours. Replace if necessary. The belts are not adjustable. Replace belts if they begin to slip from wear.

TRANSAXLE COOLING

Keep transaxle free from build-up of dirt and chaff which can restrict cooling.

ENGINE

LUBRICATION

Change the oil after the first two hours of operation and every 50 hours thereafter or at least once a year if the tractor is not used for 50 hours in one year.

Check the crankcase oil level before starting the engine and after each eight (8) hours of continuous use. Add SAE 30W motor oil or equivalent. Tighten oil fill cap/dipstick securely each time you check the oil level. SAE 5W-30 motor oil may be used to make starting easier in areas where temperature is consistently 32° F or lower.

TO CHANGE ENGINE OIL (See Figs. 22, 23 and 24)

Determine temperature range expected before oil change. All oil must meet API service classification SG.

- Be sure vehicle is on level surface.
- Oil will drain more freely when warm.
- Catch oil in a suitable container.
- Remove oil filler cap. Be careful not to allow dirt to enter the engine when changing oil.

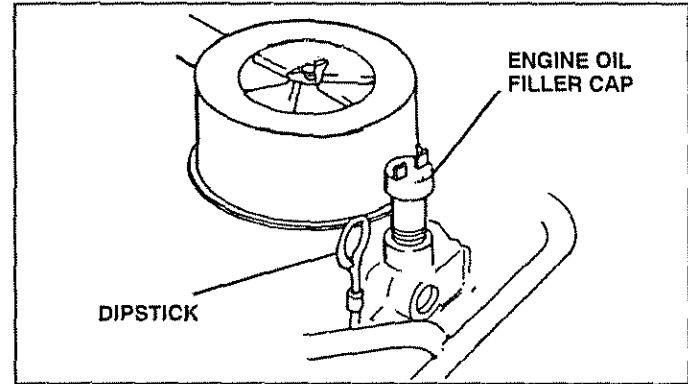

FIG. 22

- Remove drain plug

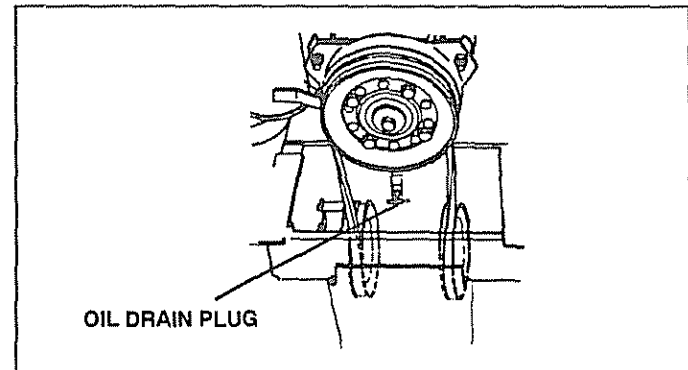

FIG. 23

- After oil has drained completely, replace oil drain plug and tighten securely.
- Refill engine with oil through oil filler tube. Pour slowly. Do not overfill. For approximate capacity see "Product Specifications" on page 3 of this manual.
- Use gauge on dipstick for checking level. Be sure dipstick is in all the way for accurate reading. Keep oil at "FULL" line on dipstick.

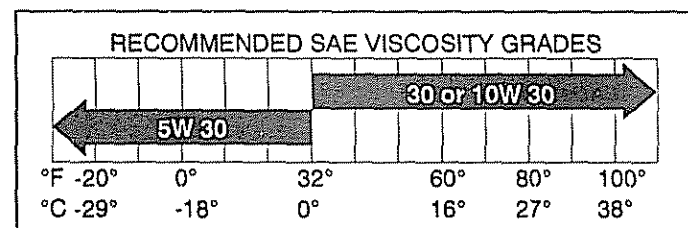

FIG. 24

CUSTOMER RESPONSIBILITIES

CLEAN AIR SCREEN (See Fig. 25)

Air screen must be kept free of dirt and chaff to prevent engine damage from overheating. Clean with a wire brush or compressed air to remove dirt and stubborn dried gum fibers.

CLEAN ENGINE COOLING FINS (See Fig. 25)

Remove any dust, dirt or oil from engine cooling fins to prevent engine damage from overheating. Engine blower housing must be removed. Remove side panels and hood (See "TO REMOVE HOOD AND GRILL ASSEMBLY" in the Service and Adjustments section of this manual.)

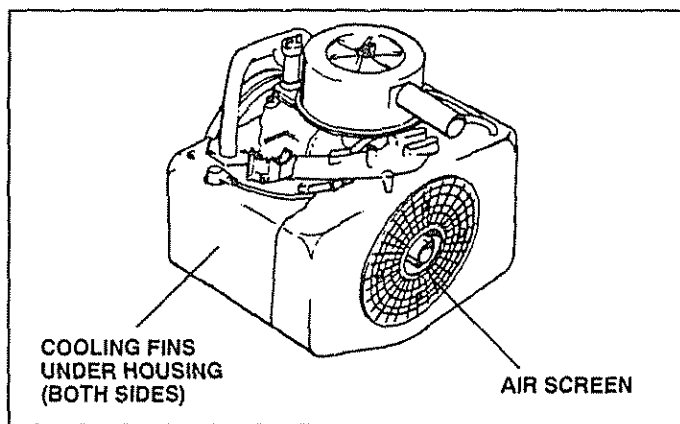

FIG. 25

AIR FILTER FOAM PRE-CLEANER (See Fig. 26)

Your engine will not run properly and may be damaged by using a dirty air filter. Clean the foam pre-cleaner element after every 25 hours of operation, more often if tractor is used in very dusty, dirty conditions.

- Remove the wing nut and air cleaner cover.
- Remove the element cover seal, element cover, paper element, and pre-cleaner.

NOTE: Do not attempt to clean or oil the paper cartridge. Replace paper cartridge once a year or after every 100 hours of operation, more often if used in very dusty, dirty conditions.

- Wash foam pre-cleaner in liquid detergent and water.
- Wrap foam pre-cleaner in cloth and squeeze dry.
- Lightly coat foam pre-cleaner with clean engine oil. Squeeze in towel to remove excess oil. Do not saturate.
- Install the paper element, pre-cleaner (cleaned and oiled), element cover, and element cover seal.
- Install the air cleaner cover and wing nut. Tighten wing nut 1/2 to 1 full turn after nut contacts cover. Do not over-tighten.

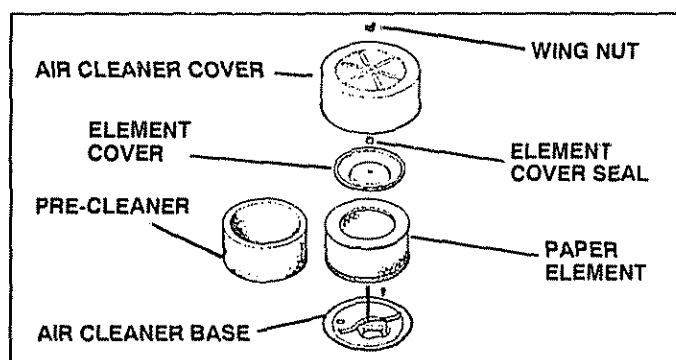

FIG. 26

MUFFLER

Inspect and replace corroded muffler and spark arrester (if equipped) as it could create a fire hazard and/or damage.

SPARK PLUGS

Replace spark plugs at the beginning of each mowing season or after every 100 hours of use, whichever comes first. Spark plug type and gap setting is shown in "PRODUCT SPECIFICATIONS" on page 3 of this manual.

ENGINE OIL FILTER

Replace the engine oil filter every season or every other oil change if the tractor is used more than 100 hours in one year.

IN-LINE FUEL FILTER (See Fig. 27)

Fuel filter should be replaced once each season. If fuel filter becomes clogged, obstructing fuel flow to carburetor, replacement is required.

- With engine cool, remove filter and plug fuel line sections.
- Place new fuel filter in position in fuel line with arrow pointing towards carburetor.
- Be sure there are no fuel line leaks and clamps are properly positioned.
- Immediately wipe up any spilled gasoline.

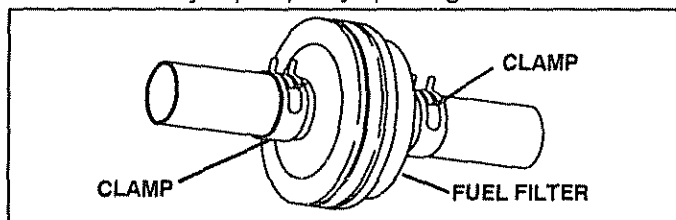

FIG. 27

CLEANING

- Clean engine, battery, seat, finish, etc. of all foreign matter.
- Keep finished surfaces and wheels free of all gasoline, oil, etc.
- Protect painted surfaces with automotive type wax.

We do not recommend using a garden hose to clean your unit unless the electrical system, muffler, air filter and carburetor are covered to keep water out. Water in engine can result in a shortened engine life.

SERVICE AND ADJUSTMENTS



CAUTION: BEFORE PERFORMING ANY SERVICE OR ADJUSTMENTS:

- Depress clutch/brake pedal fully and set parking brake.
- Place gearshift lever in "NEUTRAL" position.
- Place attachment clutch in "DISENGAGED" position.
- Turn ignition key "OFF" and remove key.
- Make sure the blades and all moving parts have completely stopped.
- Disconnect spark plug wire from spark plug and place wire where it cannot come in contact with plug.

TRACTOR

TO REMOVE MOWER (See Fig. 28)

- Place attachment clutch in "DISENGAGED" position.
- Turn height adjustment knob to lowest setting.
- Move attachment lift lever forward to lower mower to its lowest position.
- Pull the four (4) release pins out of suspension brackets.
- Pull back attachment lift lever and lock into place
- Slide mower forward and remove belt from primary mandrel.
- Slide mower out from under tractor.

IMPORTANT: IF AN ATTACHMENT OTHER THAN THE MOWER DECK IS TO BE MOUNTED ON THE TRACTOR, REMOVE THE L.H. AND R.H. SUSPENSION ARMS AND THE FRONT SUSPENSION BRACKET.

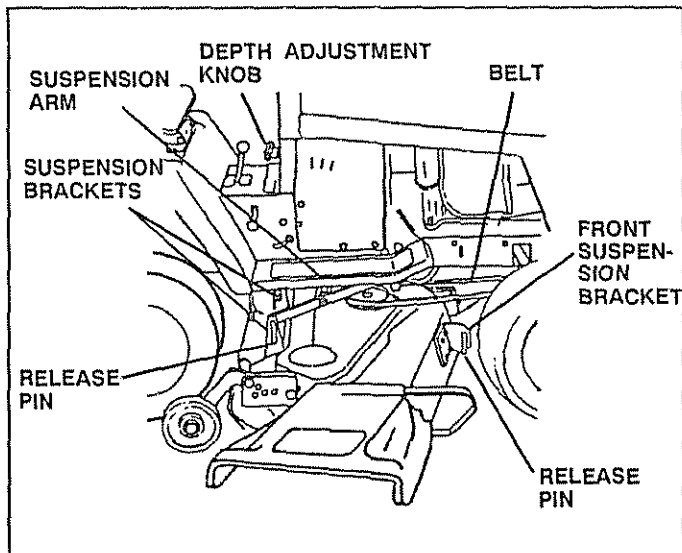

FIG. 28

TO INSTALL MOWER

Follow procedure described in "INSTALL MOWER AND DRIVE BELT" in Assembly section of this manual.

TO LEVEL MOWER HOUSING

Adjust the mower while tractor is parked on level ground or driveway. Make sure tires are properly inflated (See "PRODUCT SPECIFICATIONS" on page 3). If tires are over or underinflated, you will not properly adjust your mower.

SIDE-TO-SIDE ADJUSTMENT (See Figs. 29 and 30)

- Raise mower to its highest position.

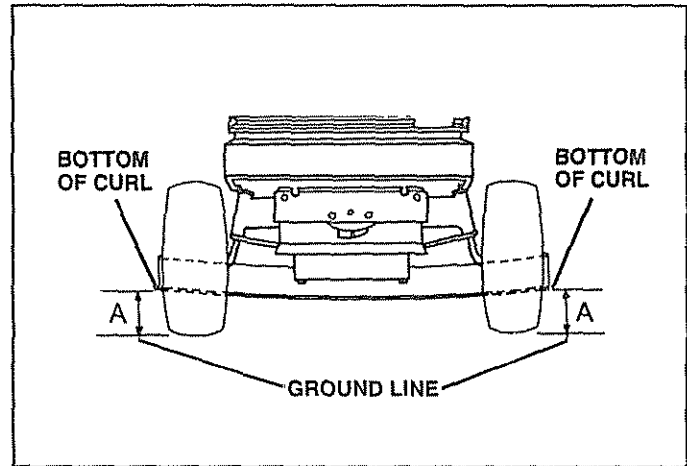

FIG. 29

- Measure height from bottom of deck curl to ground level at front corners of mower. Distance "A" should be the same.
- If distance "A" needs to be changed, snap out access hole cover on left side of tractor above footrest.
- To raise left side of mower, loosen nut "B" and tighten nut "C".
- To lower left side of mower, loosen nut "C" and tighten nut "B".
- When distance "A" is equal, securely tighten nuts "B" and "C".
- Replace access hole cover.

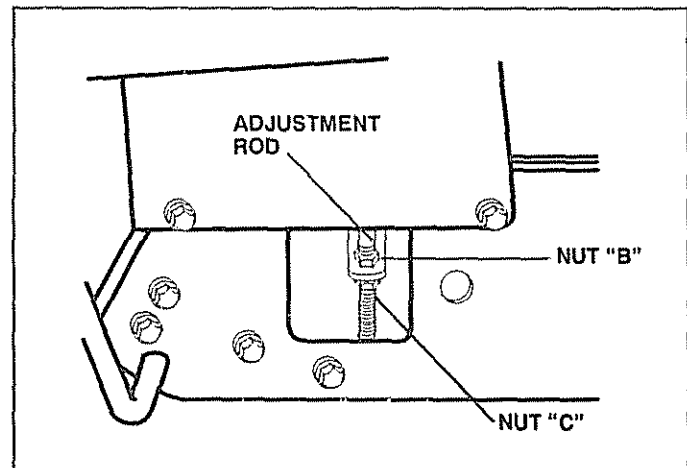

FIG. 30

SERVICE AND ADJUSTMENTS

FRONT-TO-BACK ADJUSTMENT (See Figs. 31 and 32)

To obtain the best cutting results, the mower housing should be adjusted so the back is approximately 7/8" to 1-1/8" higher than the front when the mower is in height adjustment position.

Measure distance "D" from ground line to bottom of deck curl at centerline outside of mandrels.

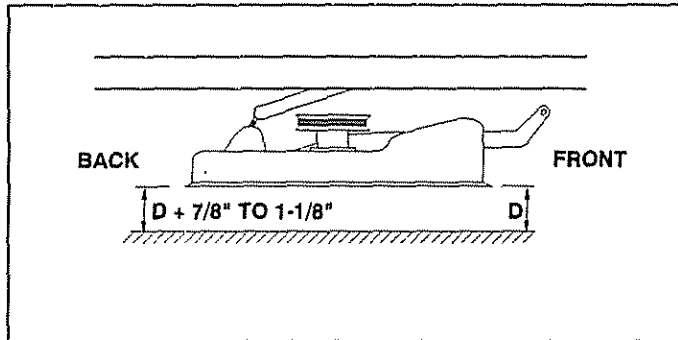

FIG. 31

- To raise rear of mower, loosen nut "E" on both rear suspension arms. Screw both nuts "F" on both rear suspension arms an equal number of turns.
- When distance "D" is 7/8" to 1-1/8" higher at rear than front, retighten nuts "E".

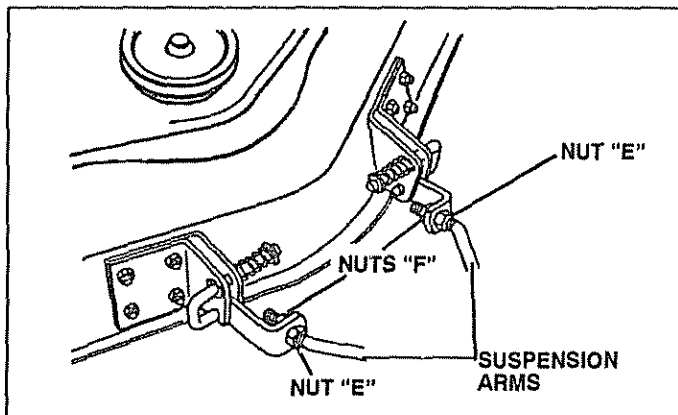

FIG. 32

- Recheck side-to-side adjustment.

IMPORTANT: WHEN ADJUSTING REAR SUSPENSION ARMS, ALWAYS ADJUST BOTH EQUALLY SO MOWER WILL STAY LEVEL SIDE-TO-SIDE.

TO ADJUST MOWER DRIVE BELT (See Fig. 33)

- Lower mower with attachment lift lever.
- Check dimension "A" on idler bracket assembly as shown. If dimension is 1/4" or less, belt should be adjusted.
- Pull tension pulley lever forward to loosen belt.
- Remove idler pulley and reassemble in "NEW" pulley position hole. Tighten securely.
- Push tension pulley lever rearward into operating position.
- Check belt for proper position in all pulley grooves.

NOTE: When installing a new replacement mower drive belt, idler pulley must be moved back to "ORIGINAL" pulley position.

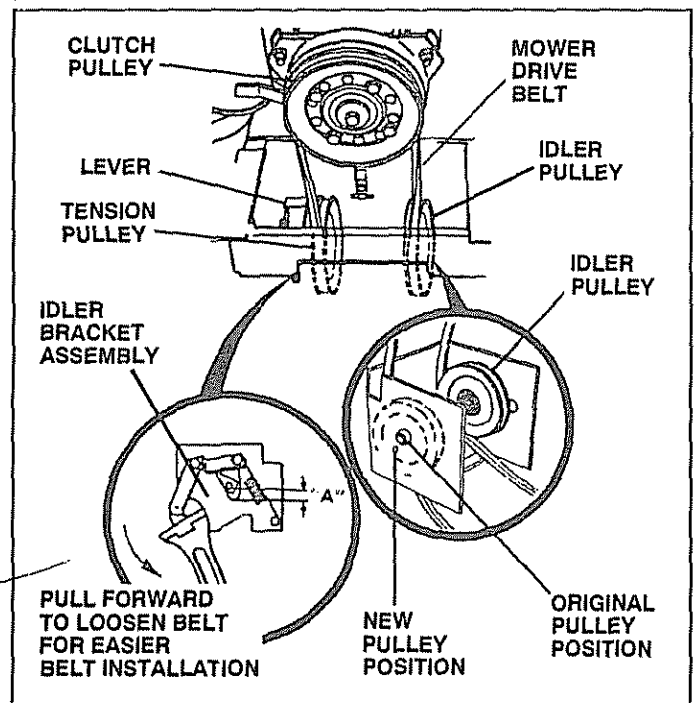

FIG. 33

TO REPLACE MOWER DRIVE BELT

Reverse procedure and install new belt as described in "DRIVE BELT INSTALLATION" in the Assembly section of this manual.

NOTE: If old mower drive belt was adjusted, idler pulley must be moved back to "ORIGINAL" position when installing a new belt.

SERVICE AND ADJUSTMENTS

TO REPLACE MOWER BLADE DRIVE BELT (See Fig. 34)

Park the tractor on level surface. Engage parking brake. For assistance, there is a belt installation guide decal on the underside of mower belt cover.

- Remove mower (See "TO REMOVE MOWER" in this section of this manual).
- Remove screws and idler arm nut securing mower belt cover and remove cover.
- Roll belt over the top of the R.H. mandrel.
- Pull belt off all other mandrels.
- Remove any dirt and grass which may have accumulated mandrels or idler arm.
- Check deck idler arm assembly and flat idler to see that they rotate freely.
- Be sure spring is hooked in deck idler arm assembly and on bolt in mower housing.
- Install new belt in groove of L.H. mandrel pulley, lower groove of center mandrel pulley and around flat idler as shown.
- From a position at discharge end of mower, roll idler belt into groove of R.H. mandrel pulley.
- Rotate center mandrel pulley by hand to make sure belt is in grooves properly.
- Reassemble top cover to deck. Tighten all screws and idler arm nut securely.
- Install mower to tractor (See "INSTALL MOWER AND DRIVE BELT" in the Assembly section of this manual.)

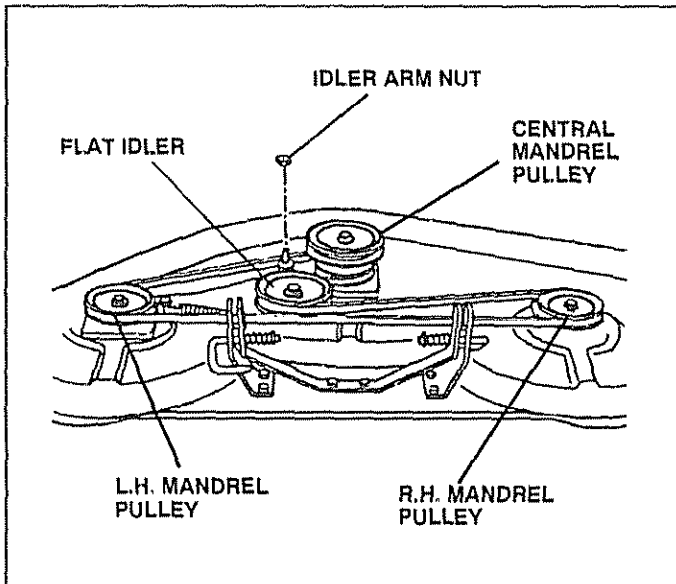

FIG. 34

POWER TAKE OFF (CLUTCH PULLEY - See Fig. 33)

The power take-off clutch should provide years of service. The clutch incorporates a built in brake that stops the pulley almost immediately. Eventually, the internal brake will wear so the mower blades will not stop as recommended. Adjustment should be made by your nearest Authorized Service Center.

TO ADJUST BRAKE (See Figs. 35 and 36)

Your unit is equipped with an adjustable brake system which is mounted on the right side of the transaxle.

If unit requires more than six (6) feet stopping distance at high speed in highest gear, then brake must be adjusted.

- Remove four (4) hex washer head tapping screws from shift cover plate located on top of tractor frame. Remove the cover plate.
- Loosen jam nut (A) on brake rod (B) at clevis (C) (Fig. 36). If you find it difficult to loosen jam nut (A), remove cover plate in L.H. frame rail.
- Rotate brake rod (b) counterclockwise, turning brake rod out of clevis (c) four (4) to six (6) turns.
- Start tractor with transaxle in "N" (neutral) position.
- Depress clutch/brake pedal to the point where the belt stops moving. Hold clutch/brake pedal in position by engaging parking brake. If belt begins to move after engaging parking brake, depress clutch/brake pedal to next notch on parking brake.
- Shut engine off. Rotate brake rod (B) clockwise by hand, turning brake rod into clevis (C) until tight. Tighten jam nut (A) on brake rod (B) at clevis (C).
- Reinstall shift cover plate and four (4) mounting screws. If cover plate in L.H. rail was removed it should be replaced.

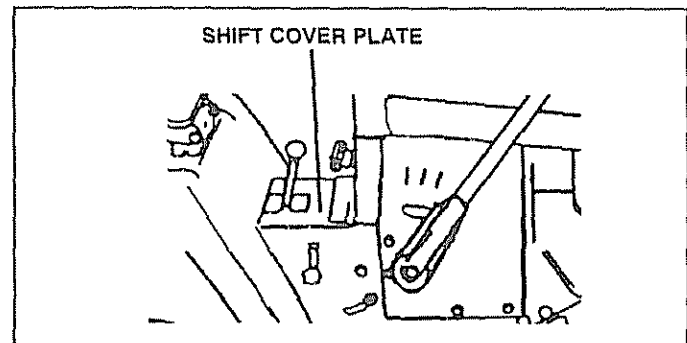

FIG. 35

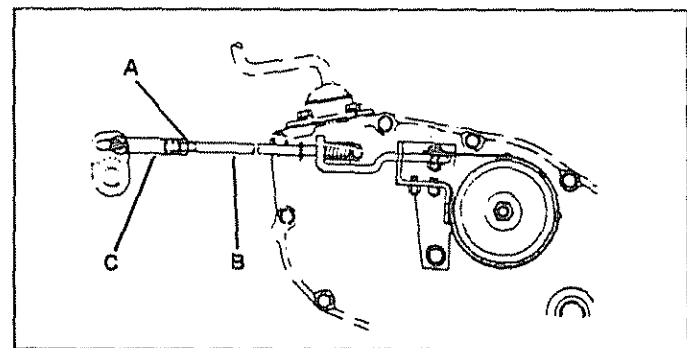

FIG. 36

SERVICE AND ADJUSTMENTS

TO REPLACE MOTION DRIVE BELT (See Figs. 37 and 38)

Park the tractor on level surface. Engage parking brake. For ease of service there is a belt installation guide decal on bottom side of left footrest. It is not necessary to remove mower.

BELT REMOVAL

- Raise hood and disconnect negative ground battery cable.
- Set parking brake (to get belt slack).
- Loosen (do not remove) two (2) engine pulley belt guide bolts and swivel R.H. side of belt guide up. Tighten L.H. bolt to hold belt guide in position.
- Roll belt off engine pulley.
- Roll belt off "V" idler, flat idler and clutching idler pulleys.
- Pull belt off clutch pulley - between pulley and frame. Pull belt off transaxle pulley.

BELT INSTALLATION

- Push belt down from engine pulley area. Place back (flat) side of belt on flat idler (flat idler is next to frame).
- Place belt on clutching idler and over clutch pulley. "V" (narrow) part of belt should engage clutch pulley.
- Place belt around transaxle pulley. "V" part of belt should engage transaxle pulley.
- Make sure "V" part of belt engages "V" idler.
- Roll belt over engine pulley.
- Loosen L.H. engine pulley belt guide bolt and swivel belt guide on to R.H. bolt. Tighten L.H. and R.H. bolts securely.
- Release parking brake.

IMPORTANT: CHECK BRAKE ADJUSTMENT.

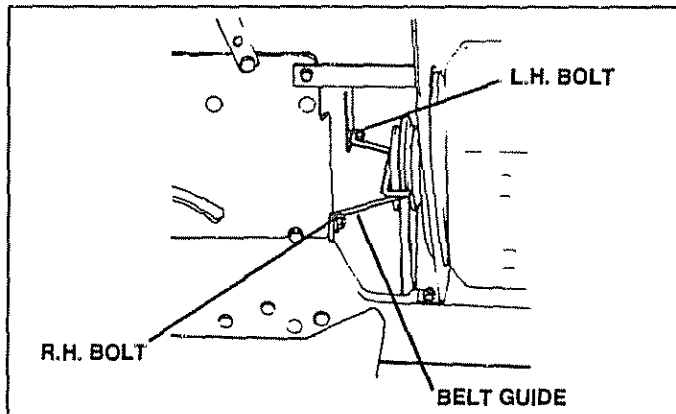

FIG. 37

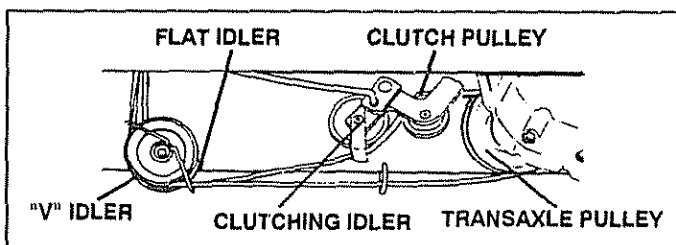

FIG. 38

TO ADJUST STEERING WHEEL ALIGNMENT

If steering wheel crossbars are not horizontal (left to right) when wheels are positioned straight forward, remove steering wheel and reassemble per instructions in the Assembly section of this manual.

FRONT WHEEL TOE-IN ADJUSTMENT

Front wheel toe-in is required for proper steering operation. Toe-in was set at the factory and adjustment should not be necessary. If parts in the front axle or steering mechanism have been replaced or damaged, check toe-in and adjust if necessary.

TO CHECK TOE-IN (See Fig. 39)

- Position front wheels straight ahead.
- Measure distance between wheels at front and rear of tires (dimensions "A" and "B").
- Front dimension "A" should be 1/8" to 1/4" less than rear dimension "B".

TO ADJUST TOE-IN (See Figs. 39 and 40)

It is important that both tie rods be equal in length before adjusting toe-in. Both tie rods should measure approximately 10-1/4" in length (see inset). Adjust if necessary.

- Loosen jam nuts at adjustment sleeves on tie rods.
- Adjust both tie rods equally until dimension "A" is 1/8" to 1/4" less than dimension "B".
- Tighten jam nuts securely.

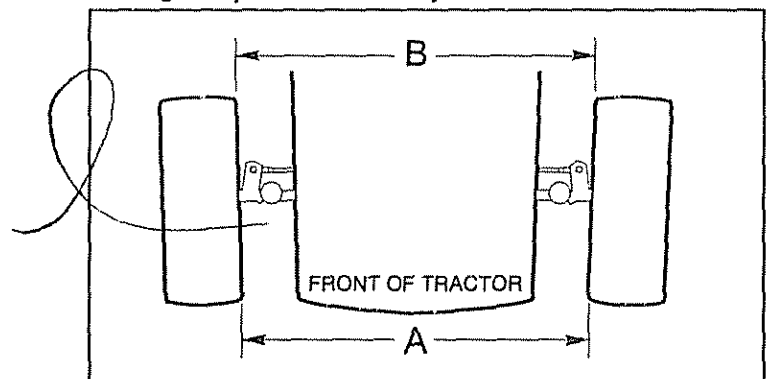

FIG. 39

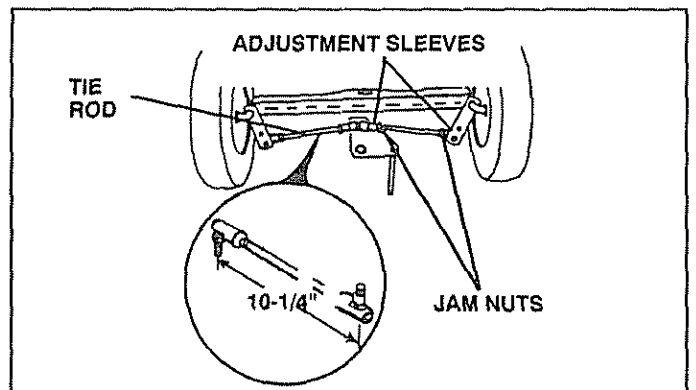

FIG. 40

FRONT WHEEL CAMBER

The front wheel camber is not adjustable on your unit. If damage has occurred to affect the front wheel camber, contact your nearest Authorized Service Center.

SERVICE AND ADJUSTMENTS

TO REMOVE WHEEL FOR REPAIRS

FRONT WHEEL (See Fig. 41) -

- Block up axle securely.
- Remove hub cap, retaining ring and washers to allow wheel removal.
- Repair tire and reassemble.
- Replace washers and snap retaining ring securely in axle groove.
- Replace hub cap.

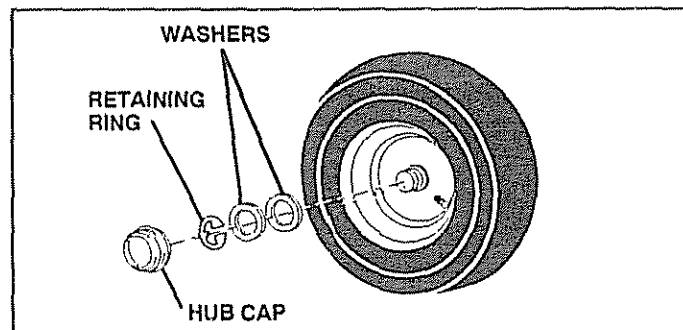

FIG. 41

REAR WHEEL -

- Block rear axle securely.
- Remove five (5) hub bolts to allow wheel removal.
- Repair tire and reassemble. Replace and tighten hub bolts securely.

TO START ENGINE WITH A WEAK BATTERY (See Fig. 42)



CAUTION: Lead-acid batteries generate explosive gases. Keep sparks, flame and smoking materials away from batteries. Always wear eye protection when around batteries.

If your battery is too weak to start the engine, it should be recharged. If "jumper cables" are used for emergency starting, follow this procedure:

IMPORTANT: YOUR UNIT IS EQUIPPED WITH A 12 VOLT NEGATIVE GROUND SYSTEM. THE OTHER VEHICLE MUST ALSO BE A 12 VOLT NEGATIVE GROUND SYSTEM. DO NOT USE YOUR TRACTOR BATTERY TO START OTHER VEHICLES.

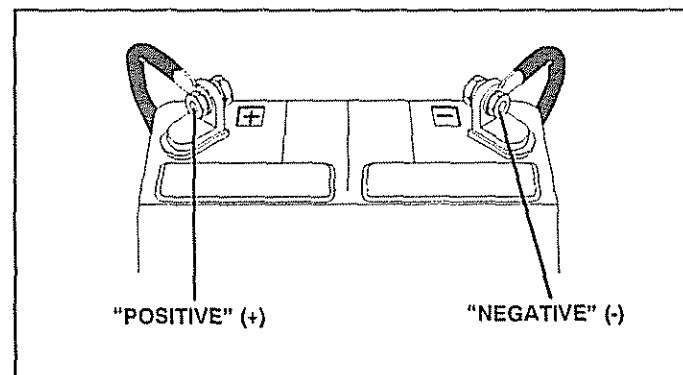

FIG. 42

TO ATTACH JUMPER CABLES -

- Connect each end of the RED cable to the POSITIVE (+) terminal of each battery, taking care not to short against chassis.
- Connect one end of the BLACK cable to the NEGATIVE (-) terminal of fully charged battery.
- Connect the other end of the BLACK cable to good CHASSIS GROUND, away from fuel tank and battery.

TO REMOVE CABLES, REVERSE ORDER -

- BLACK cable first from chassis and fully charged battery.
- RED cable last from both batteries.

TO REPLACE FUSE

Replace with 30 amp automotive-type plug-in fuse. The fuse holder is located behind the dash.

TO REPLACE HEADLIGHT BULB

- Raise hood.
- Pull bulb holder out of the hole in the backside of the grill.
- Replace bulb in holder and push bulb holder securely back into the hole in the backside of the grill.
- Close hood.

TO ADJUST ATTACHMENT LIFT SPRING (See Fig. 43)

- While holding spring bushing with wrench, loosen jam nut.
- Turn adjustment bolt clockwise to extend spring and reduce lift effort (for heavier attachments).
- Turn adjustment bolt counterclockwise (for lighter attachments).
- Retighten jam nut against spring bushing.

IMPORTANT: DO NOT ADJUST FOR MAXIMUM SPRING TENSION WHEN USING LIGHT ATTACHMENTS SUCH AS A MOWER. ADJUST LIFT LEVER SPRING TO AID IN LIFTING ATTACHMENT. DO NOT OVERPOWER SPRING. WHEN REMOVING ATTACHMENT, ALWAYS ADJUST TO SPRING TENSION TO ITS LOWEST POSITION.

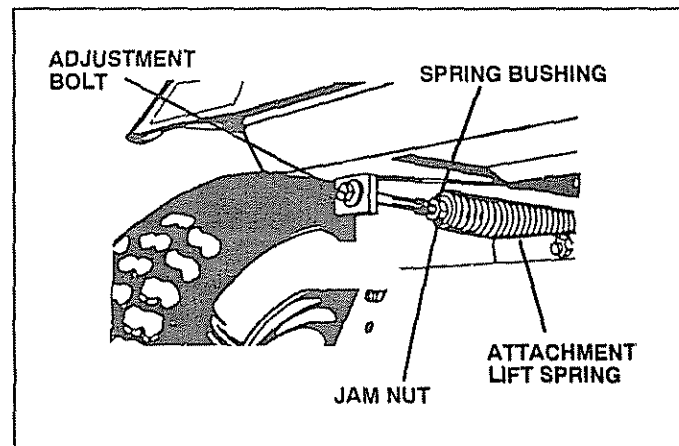

FIG. 43

SERVICE AND ADJUSTMENTS

TO REMOVE HOOD AND GRILL ASSEMBLY (See Figs. 44 and 45)

- Lift hood. Disconnect headlight wiring connection.
- Unscrew one screw at rear of each side panel.

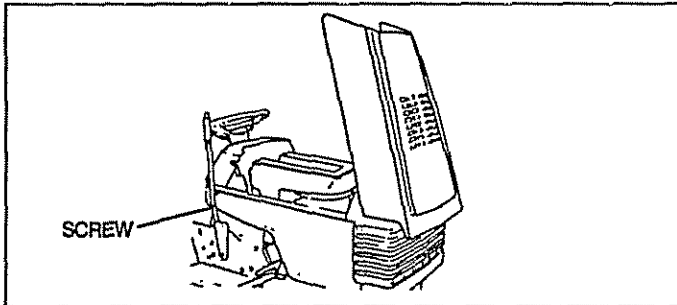

FIG. 44

- Pivot hood and side panel forward and lift off tractor.
- To replace, reverse above procedure.

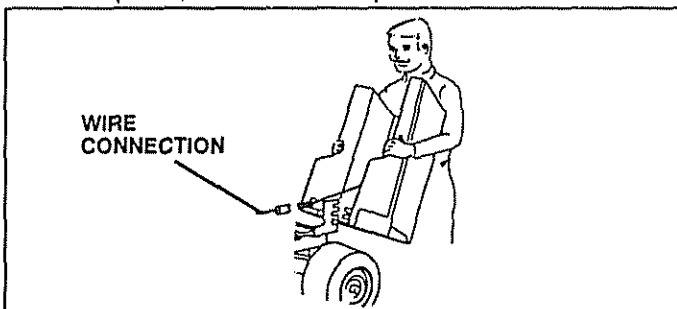

FIG. 45

SERVICE AND ADJUSTMENTS

ENGINE

TO ADJUST THROTTLE CONTROL CABLE (See Fig. 46)

The throttle control has been preset at the factory and adjustment should not be necessary. Check adjustment as described below before loosening cable. If adjustment is necessary, proceed as follows:

- With engine not running, move throttle control lever to "FAST" position.
- Check that throttle lever is against high speed stop. If it is not, loosen clamp screw and pull throttle cable until lever is against stop. Tighten clamp screw securely.

TO ADJUST CARBURETOR (See Fig. 47)

The carburetor has been present at the factory and adjustment should not be necessary. However, minor adjustment may be required to compensate for differences in fuel, temperature, altitude or load. If the carburetor does not need adjustment, proceed as follows:

In general, turning the adjusting needles **in** (clockwise) decreases the supply of fuel to the engine giving a leaner fuel/air mixture. Turning the adjusting needles **out** (counterclockwise) increases the supply of fuel to the engine giving a richer fuel/air mixture.

IMPORTANT: DAMAGE TO THE NEEDLES AND THE SEATS IN CARBURETOR MAY RESULT IF SCREW IS TURNED IN TOO TIGHT.

PRELIMINARY SETTING -

- Be sure you have a clean air filter, and the throttle control cable and choke are adjusted properly (see above).
- With engine off turn idle fuel adjusting needle **in** (clockwise) closing it finger tight and then turn **out** (counterclockwise) 1-1/4 turn.

FINAL SETTING -

- Start engine and allow to warm for five minutes. Make final adjustments with engine running and shift/motion control lever in "NEUTRAL" position.
- With throttle control lever in "FAST" position, turn main fuel adjusting needle **in** (clockwise) until engine begins to die then turn **out** (counterclockwise) until engine runs rough. Turn needle to a point midway between those two positions.
- Idle speed setting - With throttle control lever in "SLOW" position, engine should idle at 1200 RPM. If engine idles too slow or fast, turn idle speed adjusting screw in or out until correct idle is attained.
- Idle fuel needle setting - With throttle control lever in "SLOW" position, turn idle fuel adjusting needle **in** (clockwise) until engine begins to die and then turn **out** (counterclockwise) until engine runs rough. Turn needle to a point midway between those two positions.
- Recheck idle speed. Readjust if necessary.

ACCELERATION TEST -

- Move throttle control lever from "SLOW" to "FAST" position. If engine hesitates or dies, turn idle mixture screw **out** (counterclockwise) 1/8 turn. Repeat test and continue to adjust, if necessary, until engine accelerates smoothly.

High speed stop is factory adjusted. Do not adjust-damage may result.

IMPORTANT: NEVER TAMPER WITH THE ENGINE GOVERNOR, WHICH IS FACTORY SET FOR PROPER ENGINE SPEED. OVERSPEEDING THE ENGINE ABOVE THE FACTORY HIGH SPEED SETTING CAN BE DANGEROUS. IF YOU THINK THE ENGINE-GOVERNED HIGH SPEED NEEDS ADJUSTING, CONTACT YOUR NEAREST SEARS SERVICE CENTER, WHICH HAS PROPER EQUIPMENT AND EXPERIENCE TO MAKE ANY NECESSARY ADJUSTMENTS.

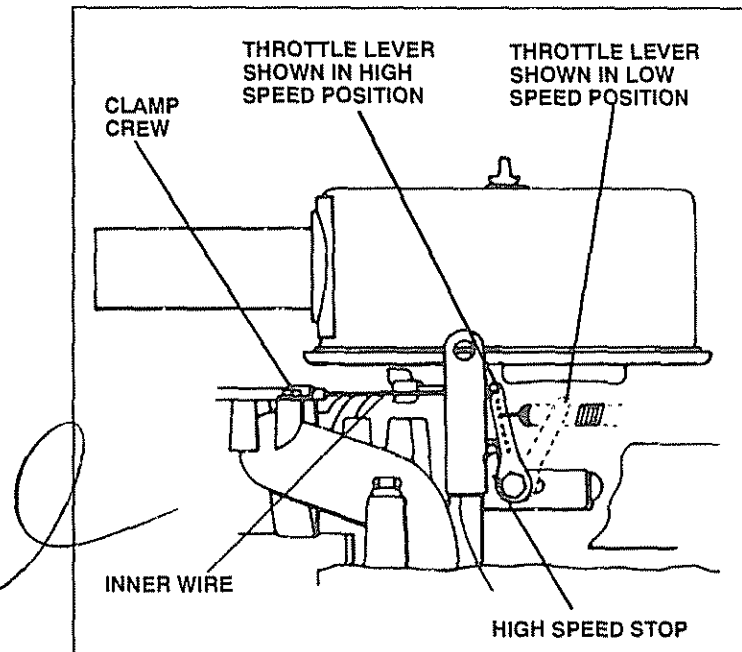

FIG. 46

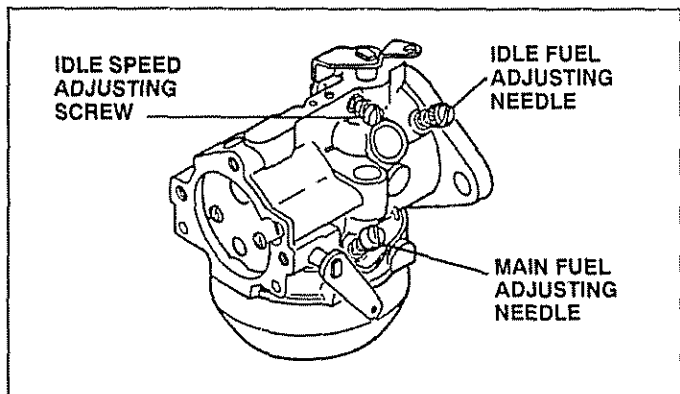

FIG. 47

STORAGE

Immediately prepare your unit for storage at the end of the season or if the unit will not be used for 30 days or more.



CAUTION: Never store the tractor with gasoline in the tank inside a building where fumes may reach an open flame or spark. Allow the engine to cool before storing in any enclosure.

TRACTOR

Remove mower from unit for winter storage. When mower is to be stored for a period of time, clean it thoroughly, remove all dirt, grease, leaves, etc. Store in a clean, dry area.

- Clean entire tractor (See "CLEANING" in the Customer Responsibilities section of this manual).
- Inspect and replace belts, if necessary (See belt replacement instructions in the Service and Adjustments section of this manual).
- Lubricate as shown in the Customer Responsibilities section of this manual.
- Be sure that all nuts, bolts and screws are securely fastened. Inspect moving parts for damage, breakage and wear. Replace if necessary.
- Touch up all rusted or chipped paint surfaces; sand lightly before painting.

BATTERY

- Fully charge the battery for storage.
- After a period of time in storage, battery may require recharging.
- To help prevent corrosion and power leakage during long periods of storage, battery cables should be disconnected and battery cleaned thoroughly (see "TO CLEAN BATTERY AND TERMINALS" in the Customer Responsibilities section of this manual).
- After cleaning, leave cables disconnected and place cables where they cannot come in contact with battery terminals.
- Be sure battery drain tube is securely attached to drain in battery tray.

ENGINE FUEL SYSTEM

IMPORTANT: IT IS IMPORTANT TO PREVENT GUM DEPOSITS FROM FORMING IN ESSENTIAL FUEL SYSTEM PARTS SUCH AS CARBURETOR, FUEL FILTER, FUEL HOSE, OR TANK DURING STORAGE. ALSO, EXPERIENCE INDICATES THAT ALCOHOL BLENDED FUELS (CALLED GASOHOL OR USING ETHANOL OR METHANOL) CAN ATTRACT MOISTURE WHICH LEADS TO SEPARATION AND FORMATION OF ACIDS DURING STORAGE. ACIDIC GAS CAN DAMAGE THE FUEL SYSTEM OF AN ENGINE WHILE IN STORAGE.

- Drain the fuel tank.
- Start the engine and let it run until the fuel lines and carburetor are empty.
- Never use engine or carburetor cleaner products in the fuel tank or permanent damage may occur.
- Use fresh fuel next season.

NOTE: Fuel stabilizer is an acceptable alternative in minimizing the formation of fuel gum deposits during storage. Add stabilizer to gasoline in fuel tank or storage container. Run engine at least 10 minutes after adding stabilizer to allow the stabilizer to reach the carburetor. Do not drain the gas tank and carburetor if using fuel stabilizer.

ENGINE OIL

Drain oil (with engine warm) and replace with clean engine oil. (See "ENGINE" in the Customer Responsibilities section of this manual).

CYLINDERS

- Remove spark plug(s).
- Pour one ounce of oil through spark plug hole(s) into cylinder(s).
- Turn ignition key to "START" position for a few seconds to distribute oil.
- Replace with new spark plug(s).

OTHER

- Do not store gasoline from one season to another.
- Replace your gasoline can if your can starts to rust. Rust and/or dirt in your gasoline will cause problems.
- If possible, store your unit indoors and cover it to give protection from dust and dirt.
- Cover your unit with a suitable protective cover that does not retain moisture. Do not use plastic. Plastic cannot breathe which allows condensation to form and will cause your unit to rust.

IMPORTANT: NEVER COVER TRACTOR WHILE ENGINE AND EXHAUST AREAS ARE STILL WARM.

TROUBLESHOOTING POINTS

PROBLEM	CAUSE	CORRECTION
Will not start	<ol style="list-style-type: none"> 1. Out of fuel. 2. Engine not "CHOKED" properly. 3. Engine flooded 4. Bad spark plug. 5. Dirty air filter. 6. Dirty fuel filter. 7. Water in fuel 8. Loose or damaged wiring. 9. Carburetor out of adjustment. 10. Engine valves out of adjustment. 	<ol style="list-style-type: none"> 1. Fill fuel tank. 2. See TO START ENGINE in Operation section. 3. Wait several minutes before attempting to start. 4. Replace spark plug. 5. Clean/replace air filter. 6. Replace fuel filter. 7. Drain fuel tank and carburetor, refill tank with fresh gasoline and replace fuel filter. 8. Check all wiring. 9. Contact Sears Service Department. 10. Contact Sears Service Department.
Hard to start	<ol style="list-style-type: none"> 1. Dirty air filter. 2. Bad spark plug 3. Weak or dead battery. 4. Dirty fuel filter. 5. Stale or dirty fuel. 6. Loose or damaged wiring. 7. Carburetor out of adjustment. 8. Engine valves out of adjustment. 	<ol style="list-style-type: none"> 1. Clean/replace air filter. 2. Replace spark plug 3. Recharge or replace battery. 4. Replace fuel filter. 5. Drain fuel tank and refill with fresh gasoline. 6. Check all wiring. 7. Contact Sears Service Department. 8. Contact Sears Service Department.
Engine will not turn over	<ol style="list-style-type: none"> 1. Clutch/brake pedal not depressed. 2. Attachment clutch is engaged. 3. Spark plug wire is disconnected. 4. Weak or dead battery. 5. Blown fuse. 6. Corroded battery terminals. 7. Loose or damaged wiring. 8. Faulty ignition switch. 9. Faulty solenoid or starter. 10. Faulty operator presence switch(es). 	<ol style="list-style-type: none"> 1. Depress clutch/brake pedal. 2. Disengage attachment clutch 3. Connect wire to spark plug. 4. Recharge or replace battery. 5. Replace fuse. 6. Clean battery terminals. 7. Check all wiring. 8. Check/replace ignition switch. 9. Check/replace solenoid or starter. 10. Contact Sears Service Department.
Engine clicks but will not start	<ol style="list-style-type: none"> 1. Weak or dead battery. 2. Corroded battery terminals. 3. Loose or damaged wiring. 4. Faulty solenoid or starter. 	<ol style="list-style-type: none"> 1. Recharge or replace battery. 2. Clean battery terminals 3. Check all wiring. 4. Check/replace solenoid or starter.
Loss of power	<ol style="list-style-type: none"> 1. Cutting too much grass/too fast 2. Throttle in "CHOKE" position. 3. Build-up of grass, leaves and trash under mower. 4. Dirty air filter 5. Low oil level/dirty oil. 6. Faulty spark plug 7. Dirty fuel filter. 8. Stale or dirty fuel. 9. Water in fuel 10. Spark plug wire loose. 11. Dirty engine air screen/fins. 12. Dirty/clogged muffler. 13. Loose or damaged wiring 14. Carburetor out of adjustment 15. Engine valves out of adjustment. 	<ol style="list-style-type: none"> 1. Set in "Higher Cut" position/reduce speed. 2. Adjust throttle control. 3. Clean underside of mower housing. 4. Clean/replace air filter. 5. Check oil level/change oil. 6. Clean and regap or change spark plug. 7. Replace fuel filter. 8. Drain fuel tank and refill with fresh gasoline. 9. Drain fuel tank and carburetor, refill tank with fresh gasoline and replace fuel filter. 10. Connect and tighten spark plug wire. 11. Clean engine air screen/fins 12. Clean/replace muffler. 13. Check all wiring. 14. Contact Sears Service Department. 15. Contact Sears Service Department.
Excessive vibration	<ol style="list-style-type: none"> 1. Worn, bent or loose blade. 2. Bent blade mandrel 3. Loose/damaged part(s). 	<ol style="list-style-type: none"> 1. Replace blade. Tighten blade bolt. 2. Replace blade mandrel 3. Tighten loose part(s). Replace damaged parts.

TROUBLESHOOTING POINTS

PROBLEM	CAUSE	CORRECTION
Engine continues to run when operator leaves seat with attachment clutch engaged	<ol style="list-style-type: none"> 1. Faulty operator-safety presence control system. 	<ol style="list-style-type: none"> 1. Check wiring, switches and connections. If not corrected, contact Sears Service Department.
Poor cut - uneven	<ol style="list-style-type: none"> 1. Worn, bent or loose blade 2. Mower deck not level. 3. Buildup of grass, leaves, and trash under mower. 4. Bent blade mandrel. 	<ol style="list-style-type: none"> 1. Replace blade. Tighten blade bolt 2. Level mower deck. 3. Clean underside of mower housing. 4. Replace blade mandrel.
Mower blades will not rotate	<ol style="list-style-type: none"> 1. Obstruction in clutch mechanism. 2. Mower drive belt out of adjustment. 3. Worn/damaged mower drive belt. 4. Frozen idler pulley. 5. Frozen blade mandrel. 	<ol style="list-style-type: none"> 1. Remove obstruction. 2. Adjust mower drive belt. 3. Replace mower drive belt. 4. Replace idler pulley. 5. Replace blade mandrel.
Poor grass discharge	<ol style="list-style-type: none"> 1. Engine speed too slow. 2. Travel speed too fast. 3. Wet grass 4. Mower deck not level. 5. Low/uneven tire air pressure. 6. Worn, bent or loose blade. 7. Buildup of grass, leaves and trash under mower. 8. Mower drive belt worn or out of adjustment. 9. Blades improperly installed. 10. Improper blades used. 	<ol style="list-style-type: none"> 1. Place throttle control in "FAST" position. 2. Shift to slower speed. 3. Allow grass to dry before mowing. 4. Level mower deck. 5. Check tires for proper air pressure. 6. Replace/sharpen blade. Tighten blade bolt. 7. Clean underside of mower housing. 8. Replace/adjust mower drive belt. 9. Reinstall blades sharp edge down. 10. Replace with blades listed in this manual.
Headlight(s) not working (if so equipped)	<ol style="list-style-type: none"> 1. Switch is "OFF". 2. Bulb(s) burned out. 3. Faulty light switch. 4. Loose or damaged wiring. 5. Blown fuse 	<ol style="list-style-type: none"> 1. Turn switch "ON". 2. Replace bulb(s). 3. Check/replace light switch. 4. Check wiring and connections. 5. Replace fuse
Battery will not charge	<ol style="list-style-type: none"> 1. Bad battery cell(s). 2. Poor cable connections. 3. Faulty regulator (if so equipped). 4. Faulty alternator 	<ol style="list-style-type: none"> 1. Replace battery. 2. Check/clean all connections. 3. Replace regulator. 4. Replace alternator.