

SEARS
OWNER'S
MANUAL

MODEL NO.
917.298560

Caution:
Read and follow
all Safety Rules
and Instructions
Before Operating
This Equipment

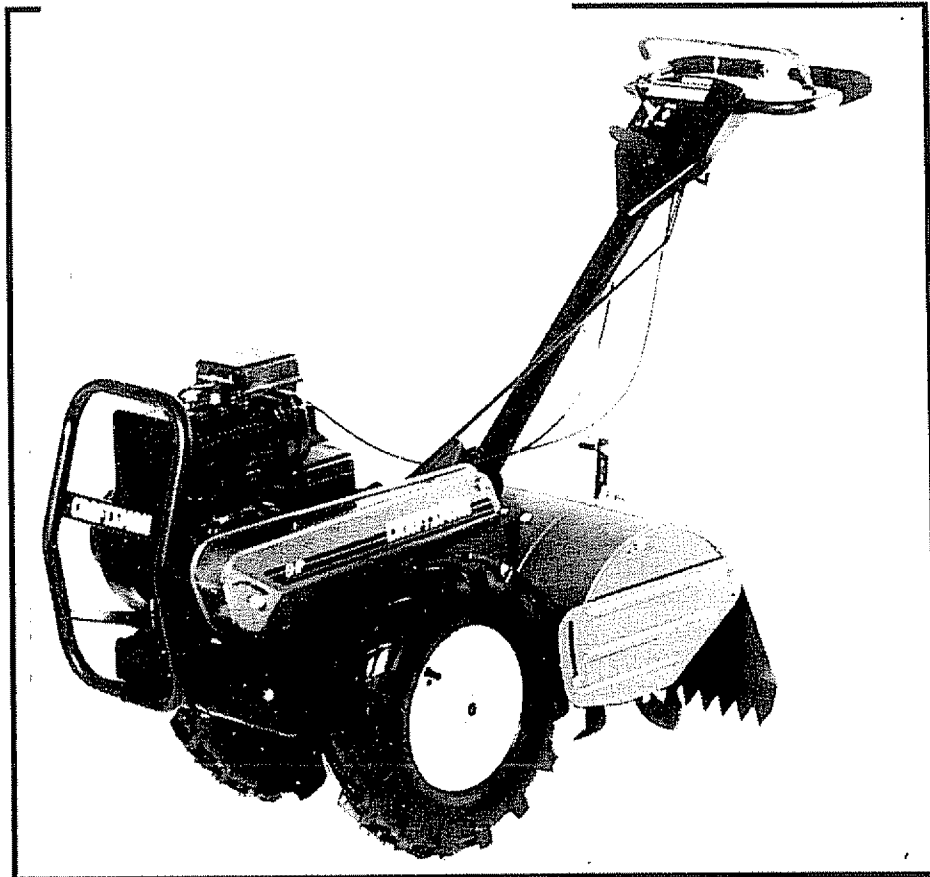

CRAFTSMAN[®]
5.0 HP
17 INCH TINE WIDTH
REAR TINE TILLER WITH
COUNTER ROTATING TINES

- Assembly
- Operation
- Customer Responsibilities
- Service and Adjustments
- Repair Parts



SAFETY RULES



Safe Operation Practices for Walk-Behind Powered Rotary Tillers

TRAINING

- Read the Owner's Manual carefully. Be thoroughly familiar with the controls and the proper use of the equipment. Know how to stop the unit and disengage the controls quickly.
- Never allow children to operate the equipment. Never allow adults to operate the equipment without proper instruction.
- Keep the area of operation clear of all persons, particularly small children, and pets.

PREPARATION

- Thoroughly inspect the area where the equipment is to be used and remove all foreign objects.
- Disengage all clutches and shift into neutral before starting the engine (motor).
- Do not operate the equipment without wearing adequate outer garments. Wear footwear that will improve footing on slippery surfaces.
- Handle fuel with care; it is highly flammable.
 - Use an approved fuel container.
 - Never add fuel to a running engine or hot engine.
 - Fill fuel tank outdoors with extreme care. Never fill fuel tank indoors.
 - Replace gasoline cap securely and clean up spilled fuel before restarting.
- Use extension cords and receptacles as specified by the manufacturer for all units with electric drive motors or electric starting motors.
- Never attempt to make any adjustments while the engine (motor) is running (except where specifically recommended by manufacturer).

OPERATION

- Do not put hands or feet near or under rotating parts.
- Exercise extreme caution when operating on or crossing gravel drives, walks, or roads. Stay alert for hidden hazards or traffic. Do not carry passengers.
- After striking a foreign object, stop the engine (motor), remove the wire from the spark plug, thoroughly inspect the tiller for any damage, and repair the damage before restarting and operating the tiller.
- Exercise caution to avoid slipping or falling.

- If the unit should start to vibrate abnormally, stop the engine (motor) and check immediately for the cause. Vibration is generally a warning of trouble.
- Stop the engine (motor) when leaving the operating position.
- Take all possible precautions when leaving the machine unattended. Disengage the tines, shift into neutral, and stop the engine.
- Before cleaning, repairing, or inspecting, shut off the engine and make certain all moving parts have stopped. Disconnect the spark plug wire, and keep the wire away from the plug to prevent accidental starting. Disconnect the cord on electric motors.
- Do not run the engine indoors; exhaust fumes are dangerous.
- Never operate the tiller without proper guards, plates, or other safety protective devices in place.
- Keep children and pets away.
- Do not overload the machine capacity by attempting to till too deep at too fast a rate.
- Never operate the machine at high speeds on slippery surfaces. Look behind and use care when backing.
- Never allow bystanders near the unit.
- Use only attachments and accessories approved by the manufacturer of the tiller (such as wheel weights, counterweights, cabs, and the like).
- Never operate the tiller without good visibility or light.
- Be careful when tilling in hard ground. The tines may catch in the ground and propel the tiller forward. If this occurs, let go of the handlebars and do not restrain the machine.

MAINTENANCE AND STORAGE

- Keep machine, attachments, and accessories in safe working condition.
- Check shear pins, engine mounting bolts, and other bolts at frequent intervals for proper tightness to be sure the equipment is in safe working condition.
- Never store the machine with fuel in the fuel tank inside a building where ignition sources are present, such as hot water and space heaters, clothes dryers, and the like. Allow the engine to cool before storing in any enclosure.
- Always refer to the operator's guide instructions for important details if the tiller is to be stored for an extended period.

- IMPORTANT -

CAUTION, IMPORTANTS, AND NOTES ARE A MEANS OF ATTRACTING ATTENTION TO IMPORTANT OR CRITICAL INFORMATION IN THIS MANUAL.



CAUTION: Look for this symbol to point out important safety precautions. It means —Attention! Become Alert! Your safety is involved.

IMPORTANT: USED TO ALERT YOU THAT THERE IS A POSSIBILITY OF DAMAGING THIS EQUIPMENT.

NOTE: Gives essential information that will aid you to better understand, incorporate, or execute a particular set of instructions.

CONGRATULATIONS on your purchase of a Sears Tiller. It has been designed, engineered and manufactured to give you the best possible dependability and performance.

Should you experience any problems you cannot easily remedy, please contact your nearest authorized Sears Service Center/Department. They have competent, well-trained technicians and the proper tools to service or repair this unit.

Please read and retain this manual. The instructions will enable you to assemble and maintain your tiller properly. Always observe the "SAFETY RULES".

PRODUCT SPECIFICATIONS

HORSEPOWER:	5.0 HP
DISPLACEMENT:	12.57 cu. in.
GASOLINE CAPACITY:	3 Quarts Unleaded Regular
OIL : (CAPACITY: 20 oz)	SAE 30W (Above 32°F) SAE 5W-30 (Below 32°F)
SPARK PLUG : (GAP: .030")	Champion RJ19LM (STD361458)

MODEL
NUMBER **917.298560**

SERIAL
NUMBER _____

DATE OF
PURCHASE _____

THE MODEL AND SERIAL NUMBERS WILL BE FOUND ON THE MODEL PLATE ATTACHED TO THE TOP OF THE TRANSMISSION.

YOU SHOULD RECORD BOTH SERIAL NUMBER AND DATE OF PURCHASE AND KEEP IN A SAFE PLACE FOR FUTURE REFERENCE.

MAINTENANCE AGREEMENT

A Sears Maintenance Agreement is available on this product. Contact your nearest Sears store for details.

CUSTOMER RESPONSIBILITIES

- Read and observe the safety rules.
- Follow a regular schedule in maintaining, caring for and using your tiller.
- Follow the instructions under the "Customer Responsibilities" and "Storage" sections of this Owner's Manual.

LIMITED TWO YEAR WARRANTY ON CRAFTSMAN TILLER

For two years from date of purchase, when this Craftsman Tiller is maintained, lubricated, and tuned up according to the operating and maintenance instructions in the owner's manual, Sears will repair free of charge any defect in material or workmanship.

This Warranty does not cover:

- Expendable items which become worn during normal use, such as tines, spark plugs, air cleaners and belts.
- Repairs necessary because of operator abuse or negligence, including bent crankshafts and the failure to maintain the equipment according to the instructions contained in the owner's manual.
- If this Craftsman Tiller is used for commercial or rental purposes, this Warranty applies for only 30 days from the date of purchase.

WARRANTY SERVICE IS AVAILABLE BY RETURNING THE CRAFTSMAN TILLER TO THE NEAREST SEARS SERVICE CENTER/DEPARTMENT IN THE UNITED STATES. THIS WARRANTY APPLIES ONLY WHILE THIS PRODUCT IS IN USE IN THE UNITED STATES.

This Warranty gives you specific legal rights, and you may also have other rights which vary from state to state.

SEARS, ROEBUCK AND CO., D/817 WA, HOFFMAN ESTATES, ILLINOIS 60179

- IMPORTANT -

This unit is equipped with an internal combustion engine and should not be used on or near any unimproved forest-covered, brush-covered or grass covered land unless the engine's exhaust system is equipped with a spark arrester meeting applicable local or state laws (if any). If a spark arrester is used, it should be maintained in effective working order by the operator.

In the state of California the above is required by law (Section 4442 of the California Public Resources Code). Other states may have similar laws. Federal laws apply on federal lands. See your Sears Authorized Service Center/Department for spark arrester. Refer to the Repair Parts section of this manual for part number.

TABLE OF CONTENTS

SAFETY RULES 2 CUSTOMER RESPONSIBILITIES 3,13-15 PRODUCT SPECIFICATIONS 3 WARRANTY 3 ACCESSORIES 5 ASSEMBLY 6-8 OPERATION 9-12	MAINTENANCE SCHEDULE 13 SERVICE & ADJUSTMENTS 15-18 STORAGE 19 TROUBLESHOOTING 20 REPAIR PARTS-TILLER 21-27 REPAIR PARTS-ENGINE 28-32 SERVICE/PARTS ORDERING BACK COVER
---	--





INDEX

<p style="text-align: center;">A</p> Accessories 5 Adjustments: Carburetor 18 Depth Stake 10 Handle Height 15 Side Shields 11 Throttle 18 Tines 17 V-Belt (Ground Drive) 16 Air Cleaner 14	<p style="text-align: center;">B</p> Belt: Belt Guard 16 Repair Parts 22 V-Belt (Ground Drive) 16	<p style="text-align: center;">C</p> Cooling System 14 Controls: Choke 9 Throttle 9 Drive (Tines) 9 Cultivating 12 Customer Responsibilities: Air Cleaner 14 Cooling System 14 Finish 15 Maintenance Schedule 13 Muffler 15 Oil Change 14 Spark Plug 15 Tines 17 Transmission 15 V-Belt (Ground Drive) 16
<p style="text-align: center;">D</p> Depth Stake: Adjustment 10 Repair Parts 25	<p style="text-align: center;">E</p> Engine: Air Cleaner 14 Cooling System 14 Fuel Type 11	<p style="text-align: center;">F</p> Engine (cont'd) Lubrication 14 Oil Level 11 Oil Type 11,14 Spark Plug 15 Starting 12 Stopping 10 Storage 19 Winter Operation 14
<p style="text-align: center;">G</p>	<p style="text-align: center;">H</p> Handle: Height Adjustment 15 Repair Parts 21	<p style="text-align: center;">I</p>
<p style="text-align: center;">J</p>	<p style="text-align: center;">K</p>	<p style="text-align: center;">L</p> Lubrication: Lubrication Chart 13 Engine 14
<p style="text-align: center;">M</p>	<p style="text-align: center;">N</p>	<p style="text-align: center;">O</p> Oil: Level 11 Type 11,14
<p style="text-align: center;">P</p>	<p style="text-align: center;">Q</p>	<p style="text-align: center;">R</p> Operation: Cultivating 12 Fill Fuel Tank 11 Starting Engine 12 Stopping Tines & Engine 10 Tilling 10 Tilling Hints 12 Tine Operation 10 Transporting Tiller 11 Winter Operation 14
<p style="text-align: center;">S</p>	<p style="text-align: center;">T</p>	<p style="text-align: center;">U</p>
<p style="text-align: center;">V</p>	<p style="text-align: center;">W</p>	<p style="text-align: center;">X</p>
<p style="text-align: center;">Y</p>	<p style="text-align: center;">Z</p>	<p style="text-align: center;">0-9</p>

ACCESSORIES

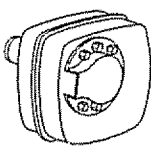
These accessories were available when the tiller was purchased. They are also available at most Sears Retail outlets, Catalog and Service Centers. Most Sears Stores can order repair parts for you when you provide the model number of your tiller.

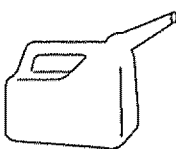



ENGINE

SPARK PLUG	MUFFLER	AIR FILTER	GAS CAN	ENGINE OIL	STABILIZER
					

TILLER PERFORMANCE

FURROW OPENER

TILLER MAINTENANCE

BELT	TINES	SHEAR PIN	HAIRPIN CLIP
			

ASSEMBLY

Your new tiller has been assembled at the factory with exception of those parts left unassembled for shipping purposes. To ensure safe and proper operation of your tiller all parts and hardware you assemble must be tightened securely. Use the correct tools as necessary to insure proper tightness.

TOOLS REQUIRED FOR ASSEMBLY

A socket wrench set will make assembly easier. Standard wrench sizes are listed.

- (1) Utility knife
- (1) Wire cutter
- (1) Screwdriver
- (1) Tire pressure gauge
- (1) Pair of pliers
- (1) 9/16" wrench

OPERATOR'S POSITION (See Fig. 1)

When right or left hand is mentioned in this manual, it means when you are in the operating position (standing behind tiller handles).

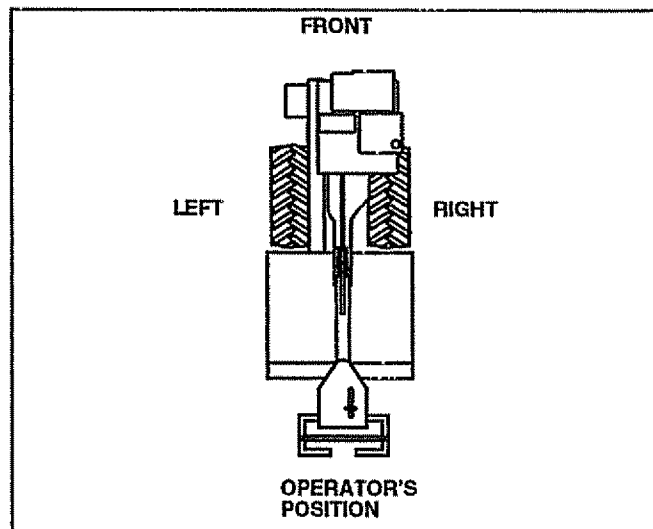
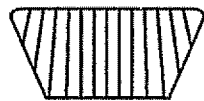
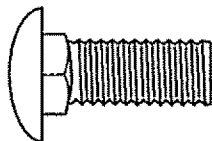

FIG. 1

CONTENTS OF HARDWARE PACK



(2) Handle Locks



(2) Carriage Bolts 3/8-16 UNC x 1 Gr. 5



(2) Center Locknuts 3/8-16 UNC

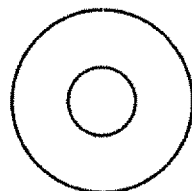

(1) Flat Washer 13/32 x 1 x 11 Ga.

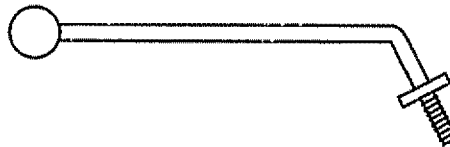

(1) Handle Lock Lever



(2) Hairpin Clips



(1) Cable Clip

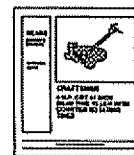

(1) Owner's Manual

ASSEMBLY

UNPACKING CARTON (See Fig. 2)



CAUTION: Be careful of exposed staples when handling or disposing of cartoning material.

IMPORTANT: WHEN UNPACKING AND ASSEMBLING TILLER, BE CAREFUL NOT TO STRETCH OR KINK CABLES.

- While holding handle assembly, cut cable ties securing handle assembly to top frame and depth stake. Let handle assembly rest on tiller.
- Remove top frame of carton.
- Slowly ease handle assembly up and place on top of carton.
- Cut down right hand front and right hand rear corners of carton, lay side carton wall down.
- Remove packing material from handle assembly.
- Separate shift rod from handle assembly.

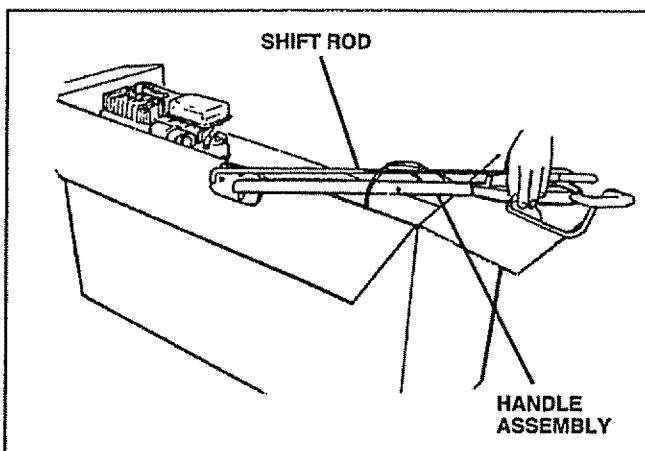

FIG. 2

INSTALL HANDLE (See Figs. 3, 4, and 5)

- Insert one handle lock (with teeth facing outward) in gearcase notch. (Apply grease on smooth side of handle lock to aid in keeping lock in place until handle assembly is lowered into position.)

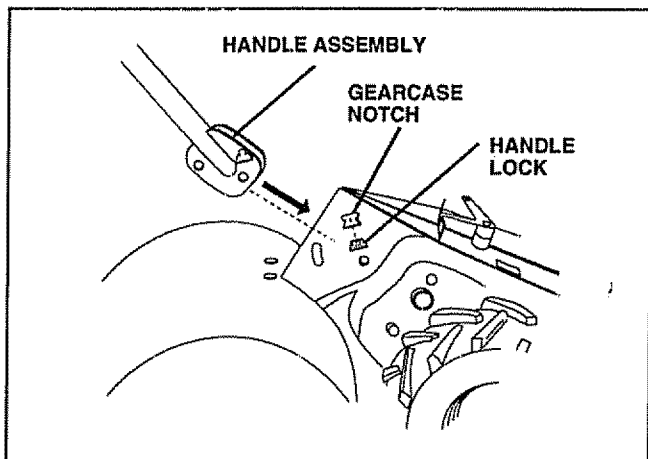

FIG. 3

- Grasp handle assembly. Hold in "up" position. Be sure handle lock remains in gearcase notch. Slide handle assembly into position.

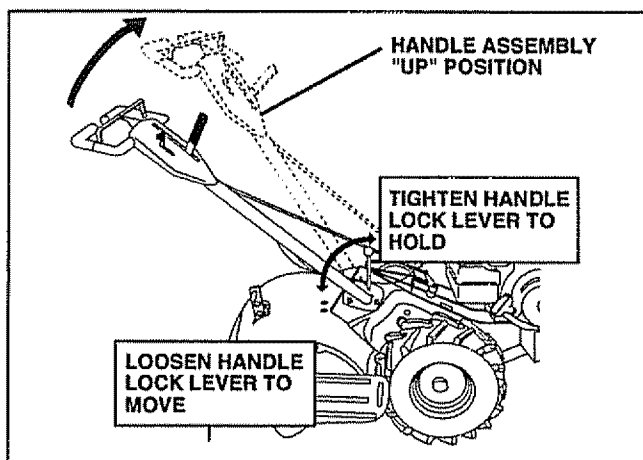

FIG. 4

- Rotate handle assembly down to install two carriage bolts and locknuts. Insert rear carriage bolt (Fig. 5) first, with head of bolt on L.H. side of tiller. Lower the handle assembly. Tighten bolts so handle moves with some resistance.
- Place flat washer on threaded end of handle lock lever.
- Insert handle lock lever through handle base and gearcase. Screw in handle lock lever just enough to hold handle in place.
- Insert second handle lock (with teeth inward) in the slot of the handle base (just inside of washer).
- With handle assembly in lowest position, securely tighten handle lock lever by rotating clockwise. Leaving handle assembly in lowest position will make it easier to remove tiller from carton.

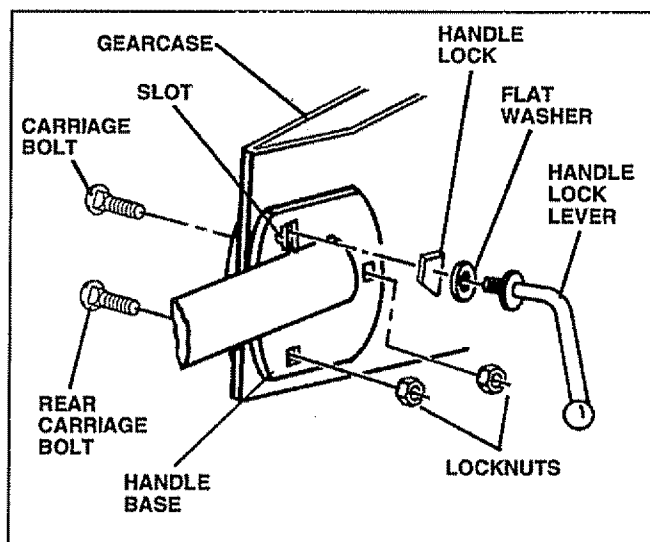

FIG. 5

ASSEMBLY

CONNECT SHIFT ROD (See Fig. 6)

- Insert end of shift rod farthest from bend into hole of shift lever indicator.
- Insert hairpin clip through hole of shift rod to secure.
- Insert other end of shift rod into hole in shift lever.
- Insert second hairpin clip through hole of shift rod.

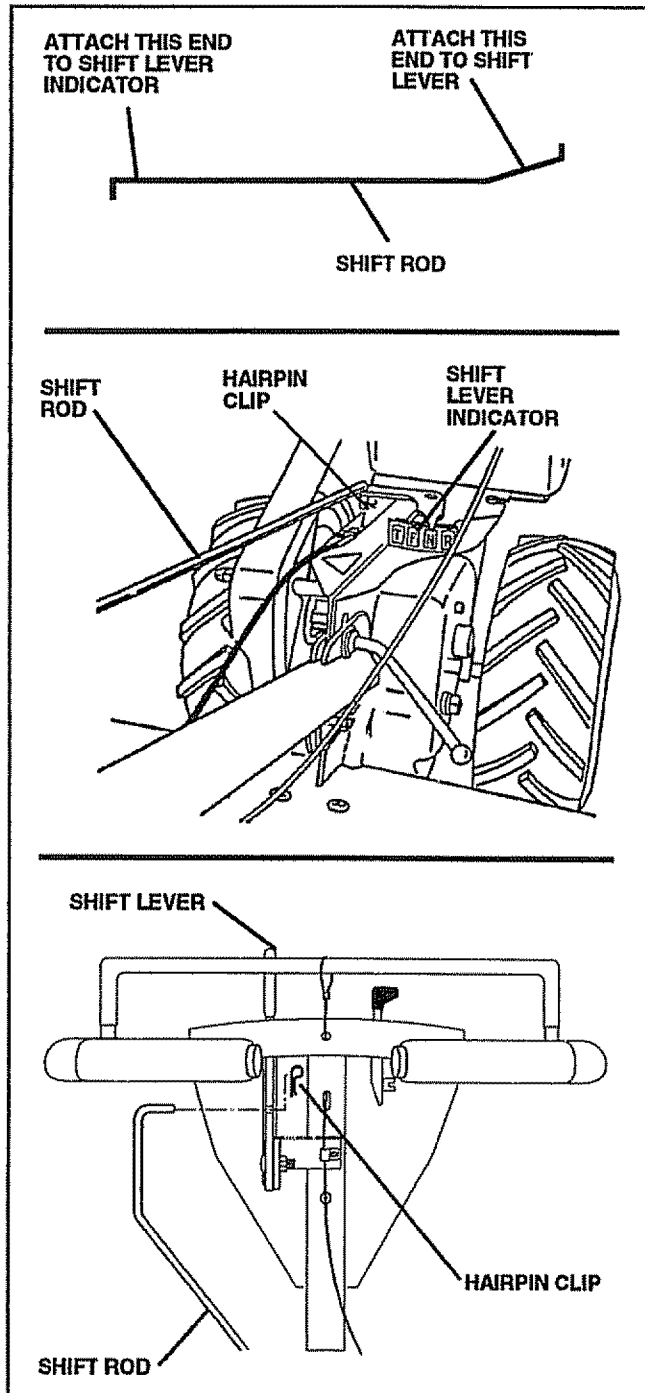

FIG. 6

REMOVE TILLER FROM CRATE

- Make sure shift lever indicator is in "N" (neutral) position (See Fig. 6)
- Tilt tiller forward by lifting handle. Separate cardboard cover from leveling shield.
- Rotate tiller handle to the right and pull tiller out of carton.

INSERT CABLE CLIP (See Fig. 7)

- Insert plastic cable clip into hole on the back of handle column. Push cables into clip.

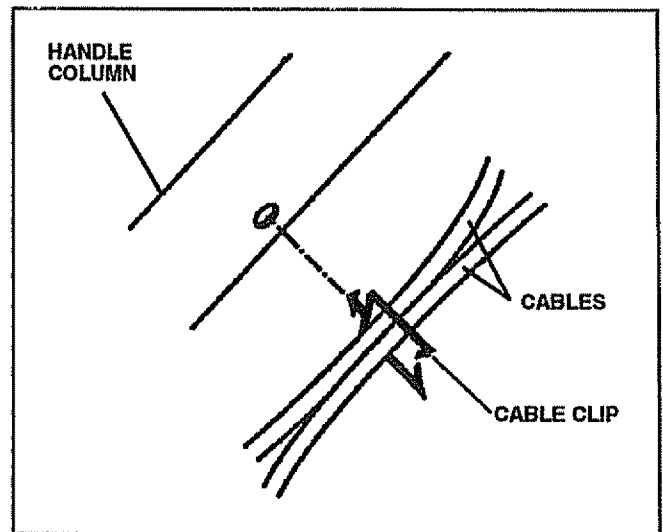

FIG. 7

CHECK TIRE PRESSURE

The tires on your unit were overinflated at the factory for shipping purposes. Correct and equal tire pressure is important for best tilling performance.

- Reduce tire pressure to 20 PSI.

HANDLE HEIGHT

- Handle height may be adjusted to better suit operator. (See "TO ADJUST HANDLE HEIGHT" in the Service and Adjustments section of this manual).

OPERATION

KNOW YOUR TILLER

READ THIS OWNER'S MANUAL AND SAFETY RULES BEFORE OPERATING YOUR TILLER.

Compare the illustrations with your tiller to familiarize yourself with the location of various controls and adjustments. Save this manual for future reference.

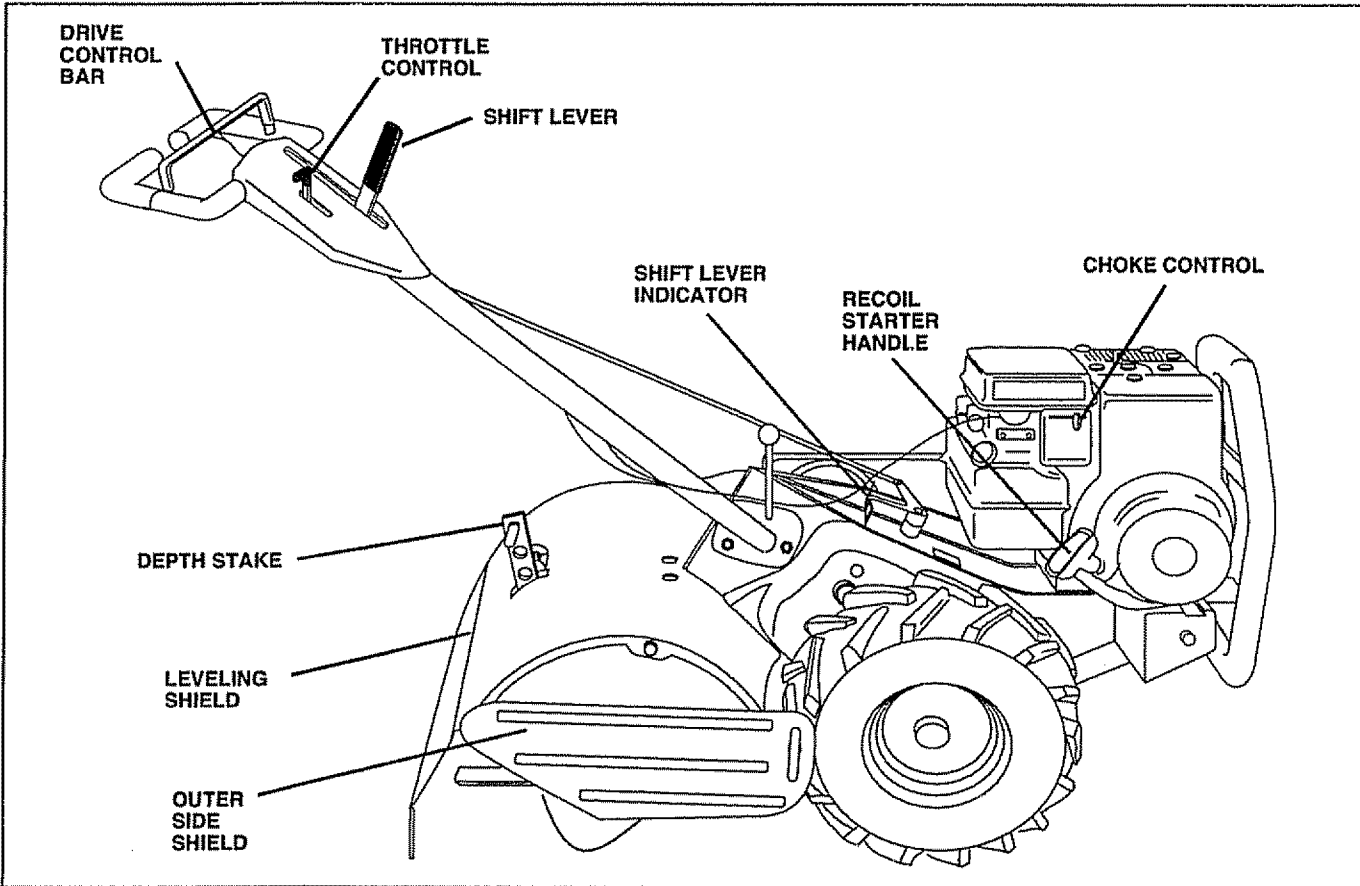

FIG. 8

MEETS ANSI SAFETY REQUIREMENTS

Our tillers conform to the safety standards of the American National Standards Institute.

DRIVE CONTROL BAR - Used to engage tines.

DEPTH STAKE - Controls depth at which tiller will dig.

LEVELING SHIELD - Levels tilled soil.

OUTER SIDE SHIELD - Adjustable to protect small plants from being buried.

THROTTLE CONTROL - Used to control engine speed.

SHIFT LEVER - Used to shift transmission gears.

SHIFT LEVER INDICATOR - Shows which gear the transmission is in.

RECOIL STARTER HANDLE - Used to start the engine.

CHOKE CONTROL - Used when starting a cold engine.

OPERATION



The operation of any tiller can result in foreign objects thrown into the eyes, which can result in severe eye damage. Always wear safety glasses or eye shields before starting your tiller and while tilling. We recommend wide vision safety mask for over the spectacles or standard safety glasses.

HOW TO USE YOUR TILLER

Know how to operate all controls before adding fuel and oil or attempting to start engine.

STOPPING (See Fig. 9)

TINES AND DRIVE

- Release drive control bar to stop movement.
- Move shift lever to "N" (neutral) position.

ENGINE

- Move throttle control to "STOP" position.
- Never use choke to stop engine.

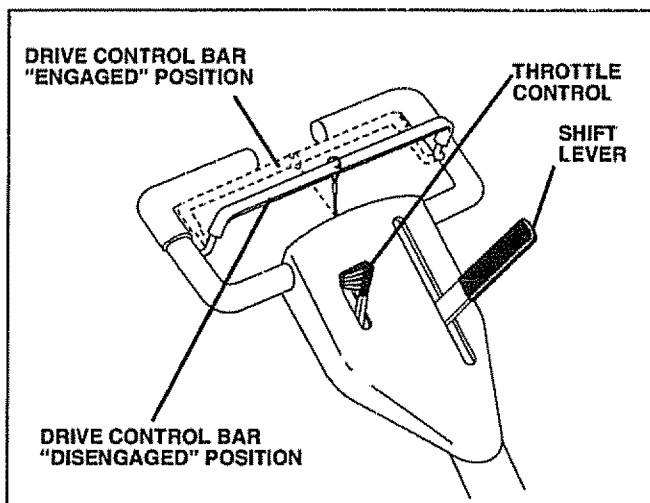

FIG. 9

TINE OPERATION - WITH WHEEL DRIVE

- Always release drive control bar before moving shift lever into another position.
- Tine movement is achieved by moving shift lever to "T" (till) position and engaging drive control bar.

FORWARD - WHEELS ONLY/TINES STOPPED

- Release drive control bar and move shift lever indicator to "F" (forward) position. Engage drive control bar and tiller will move forward.

REVERSE - WHEELS ONLY/TINES STOPPED

- DO NOT STAND DIRECTLY BEHIND TILLER.
- Release the drive control bar.
- Move throttle control to "SLOW" position.
- Move shift lever indicator to "R" (reverse) position.
- Hold drive control bar against the handle to start tiller movement.

DEPTH STAKE (See Fig. 10)

The depth stake can be raised or lowered to allow you more versatile tilling and cultivating, or to more easily transport your tiller.

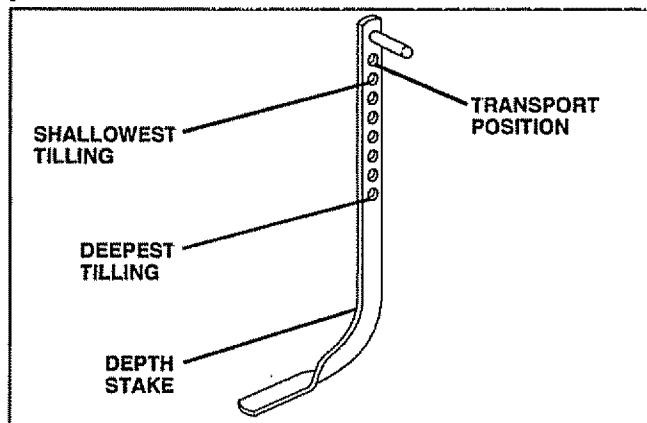

FIG. 10

TILLING (See Fig. 11)

- Release depth stake pin. Pull the depth stake up for increased tilling depth. Place depth stake pin in hole of depth stake to lock in position.
- Place shift lever indicator in "T" position.
- Hold the drive control bar against the handle to start tilling movement. Tines and wheels will both turn.
- Move throttle control to "FAST" position for deep tilling. To cultivate, throttle control can be set at any desired speed, depending on how fast or slow you wish to cultivate.

IMPORTANT: ALWAYS RELEASE DRIVE CONTROL BAR BEFORE MOVING SHIFT LEVER INTO ANOTHER POSITION.

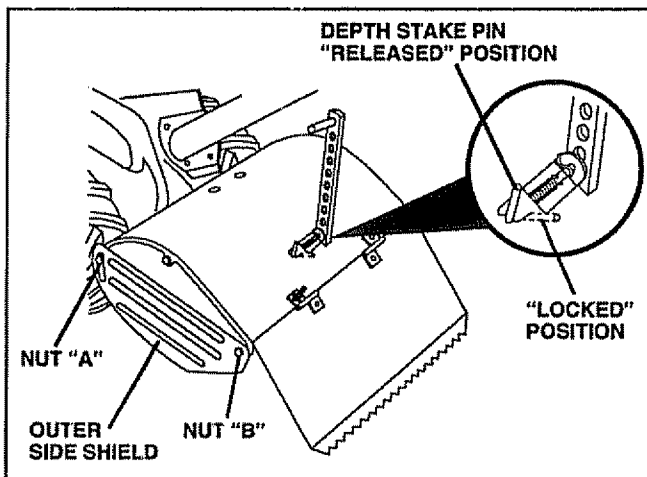

FIG. 11

OPERATION

TURNING

- Release the drive control bar.
- Move throttle control to "SLOW" position.
- Place shift lever indicator in "F" (forward) position. Tines will not turn.
- Lift handle to raise tines out of ground.
- Swing the handle in the opposite direction you wish to turn, being careful to keep feet and legs away from tines.
- When you have completed your turn-around, release the drive control bar and lower handle. Place shift lever in "T" (till) position and move throttle control to desired speed. To begin tilling, hold drive control bar against the handle.

OUTER SIDE SHIELDS (See Fig. 11)

The front edges of the outer side shields are slotted so that the shields can be raised for deep tilling and lowered for shallow tilling to protect small plants from being buried. Loosen nut "A" in slot and nut "B". Move shield to desired position (both sides). Retighten nuts.

TRANSPORTING



CAUTION: Before lifting or transporting, allow tiller engine and muffler to cool. Disconnect spark plug wire. Drain gasoline from fuel tank.

- Release the depth stake pin. Move the depth stake down to the top hole for transporting the tiller. Place depth stake pin in hole of depth stake to lock in position. This prevents tines from scuffing the ground.
- Place shift lever indicator in "F" (forward) position for transporting.
- Hold the drive control bar against the handle to start tiller movement. Tines will not turn.
- Move throttle control to desired speed.

BEFORE STARTING ENGINE

IMPORTANT: BE VERY CAREFUL NOT TO ALLOW DIRT TO ENTER THE ENGINE WHEN CHECKING OR ADDING OIL OR FUEL. USE CLEAN OIL AND FUEL AND STORE IN APPROVED, CLEAN, COVERED CONTAINERS. USE CLEAN FILL FUNNELS.

CHECK ENGINE OIL LEVEL (See Fig. 12)

- The engine in your unit has been shipped, from the factory, already filled with SAE 30 summer weight oil.
- With engine level, clean area around oil filler plug and remove plug.
- Engine oil should be to point of overflowing. For approximate capacity see "PRODUCT SPECIFICATIONS" on page 3 of this manual. All oil must meet A.P.I. Service Classification SG.
- For cold weather operation you should change oil for easier starting (See oil viscosity chart in the Customer Responsibilities section of this manual).
- To change engine oil, see the Customer Responsibilities section in this manual.

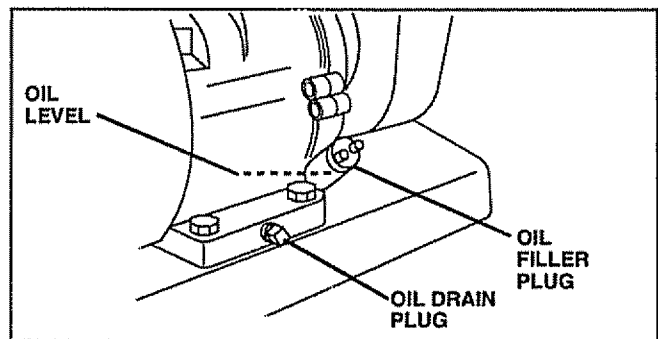

FIG. 12

ADD GASOLINE

- Fill fuel tank. Use fresh, clean, regular unleaded gasoline. (Use of leaded gasoline will increase carbon and lead oxide deposits and reduce valve life.)

IMPORTANT: WHEN OPERATING IN TEMPERATURES BELOW 32°F (0°C), USE FRESH, CLEAN, WINTER GRADE GASOLINE TO HELP INSURE GOOD COLD WEATHER STARTING.

WARNING: Experience indicates that alcohol blended fuels (called gasohol or using ethanol or methanol) can attract moisture which leads to separation and formation of acids during storage. Acidic gas can damage the fuel system of an engine while in storage. To avoid engine problems, the fuel system should be emptied before storage of 30 days or longer. Drain the gas tank, start the engine and let it run until the fuel lines and carburetor are empty. Use fresh fuel next season. See Storage section of this manual for additional information. Never use engine or carburetor cleaner products in the fuel tank or permanent damage may occur.



CAUTION: Fill to within 1/2 inch of top of fuel tank to prevent spills and to allow for fuel expansion. If gasoline is accidentally spilled, move machine away from area of spill. Avoid creating any source of ignition until gasoline vapors have disappeared.

Do not overfill. Wipe off any spilled oil or fuel. Do not store, spill or use gasoline near an open flame.

OPERATION

TO START ENGINE (See Fig. 13)



CAUTION: Keep drive control bar in "DISENGAGED" position when starting engine.

- Make sure spark plug wire is properly connected.
- Move shift lever indicator to "N" (neutral) position.
- Place throttle control in "FAST" position.
- To start a cold engine, place choke control in "CHOKE" position. A warm engine requires less choking to start.
- Grasp starter handle with one hand and grasp the tiller with other hand. Pull rope out slowly until engine reaches start of compression cycle (rope will pull slightly harder at this point).
- Pull starter handle quickly. Do not let starter handle snap back against starter.
- When engine starts, slowly move choke to "RUN" positions as engine warms up.
- Move throttle control to desired running position.
- Allow engine to warm up for a few minutes before engaging tines.

NOTE: If at a high altitude (above 3000 feet) or in cold temperatures (below 32°F), the carburetor fuel mixture may need to be adjusted for best engine performance. See "TO ADJUST CARBURETOR" in the Service and Adjustments section of this manual.

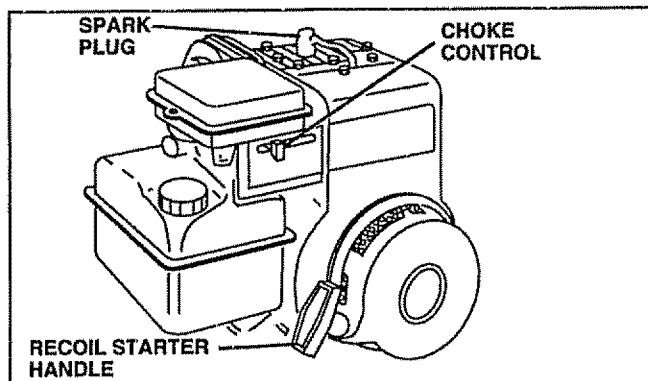

FIG. 13

TILLING HINTS



CAUTION: Until you are accustomed to handling your tiller, start actual field use with throttle in slow position (mid-way between "FAST" and "IDLE").

- Tilling is digging into, turning over, and breaking up packed soil before planting. Loose, unpacked soil helps root growth. Best tilling depth is 4" to 6". A tiller will also clear the soil of unwanted vegetation. The decomposition of this vegetable matter enriches the soil. Depending on the climate (rainfall and wind), it may be advisable to till the soil at the end of the growing season to further condition the soil.
- For easier handling of your tiller, leave about 8 inches of untilled soil between the first and second tilling passes. The third pass will be between the first and second (See Fig. 14).

- Soil conditions are important for proper tilling. Tines will not readily penetrate dry, hard soil which may contribute to excessive bounce and difficult handling of your tiller. Hard soil should be moistened before tilling; however, extremely wet soil will "ball-up" or clump during tilling. Wait until the soil is less wet in order to achieve the best results. When tilling in the fall, remove vines and long grass to prevent them from wrapping around the tine shaft and slowing your tilling operation.
- Do not lean on handle. This takes weight off the wheels and reduces traction. To get through a really tough section of sod or hard ground, apply upward pressure on handle or lower the depth stake.

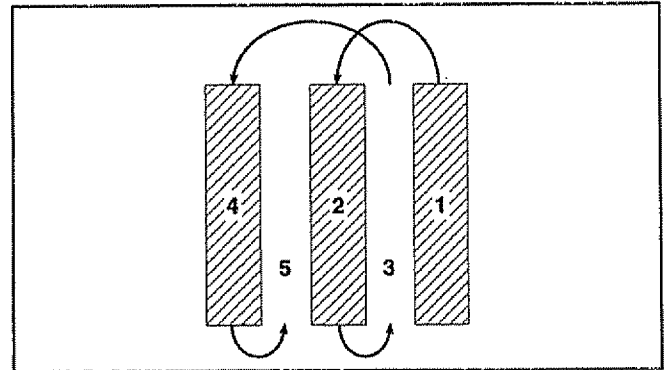

FIG. 14

CULTIVATING

Cultivating is destroying the weeds between rows to prevent them from robbing nourishment and moisture from the plants. At the same time, breaking up the upper layer of soil crust will help retain moisture in the soil. Best digging depth is 1" to 3". Lower the outer side shields to protect small plants from being buried.

- Cultivate up and down the rows at a speed which will allow tines to uproot weeds and leave the ground in rough condition, promoting no further growth of weeds and grass (See Fig. 15).

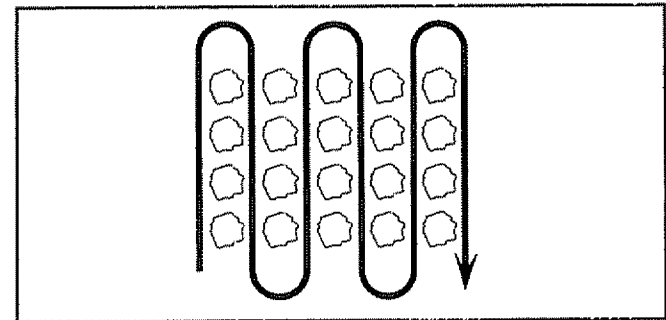

FIG. 15

TINE SHEAR PINS

The tine assemblies on your tiller are secured to the tine shaft with shear pins (See "TINE REPLACEMENT" in the Service and Adjustments section of this manual).

If the tiller is unusually overloaded or jammed, the shear pins are designed to break before internal damage occurs to the transmission.

- If shear pin(s) break, replace only with those shown in the Repair Parts section of this manual.

CUSTOMER RESPONSIBILITIES

MAINTENANCE SCHEDULE						SERVICE DATES														
	BEFORE EACH USE	FIRST 2 HOURS	EVERY 5 HOURS	EVERY 25 HOURS	EVERY 50 HOURS															
FILL IN DATES AS YOU COMPLETE REGULAR SERVICE																				
Check Engine Oil Level	✓		✓																	
Change Engine Oil		✓		✓ _{1,2}																
Oil Pivot Points			✓																	
Inspect Spark Arrester Muffler					✓															
Inspect Air Screen	✓																			
Clean or Replace Air Cleaner Cartridge				✓ ₂																
Clean Engine Cylinder Fins				✓																
Replace Spark Plug					✓															

1 - Change more often when operating under a heavy load or in high ambient temperatures.
 2 - Service more often when operating in dirty or dusty conditions.

GENERAL RECOMMENDATIONS

The warranty on this tiller does not cover items that have been subjected to operator abuse or negligence. To receive full value from the warranty, the operator must maintain tiller as instructed in this manual.

Some adjustments will need to be made periodically to properly maintain your tiller.

All adjustments in the Service and Adjustments section of this manual should be checked at least once each season.

- Once a year you should replace the spark plug, clean or replace air filter, and check tines and belts for wear. A new spark plug and clean air filter assure proper air-fuel mixture and help your engine run better and last longer.

BEFORE EACH USE

- Check engine oil level.
- Check tine operation.
- Check for loose fasteners.

LUBRICATION

Keep unit well lubricated (See "LUBRICATION CHART").

LUBRICATION CHART

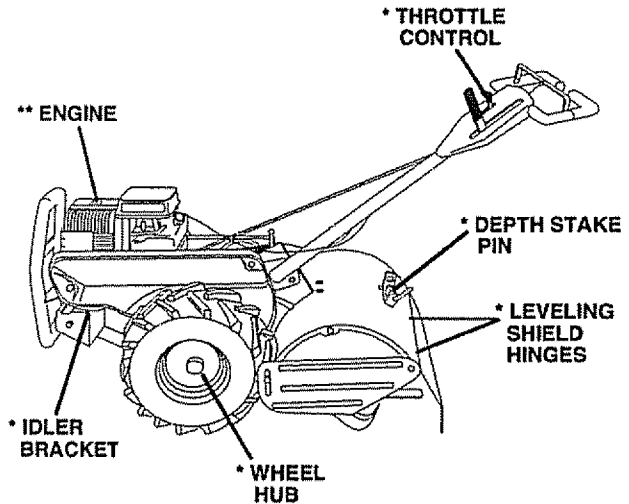

* SAE 30 OR 10W-30 MOTOR OIL

** REFER TO CUSTOMER RESPONSIBILITIES "ENGINE" SECTION

CUSTOMER RESPONSIBILITIES



Disconnect spark plug wire before performing any maintenance (except carburetor adjustment) to prevent accidental starting of engine.

Prevent fires! Keep the engine free of grass, leaves, spilled oil, or fuel. Remove fuel from tank before tipping unit for maintenance. Clean muffler area of all grass, dirt, and debris.

Do not touch hot muffler or cylinder fins as contact may cause burns.

ENGINE

LUBRICATION

Use only high quality detergent oil rated with API service classification SG. Select the oil's SAE viscosity grade according to your expected temperature.

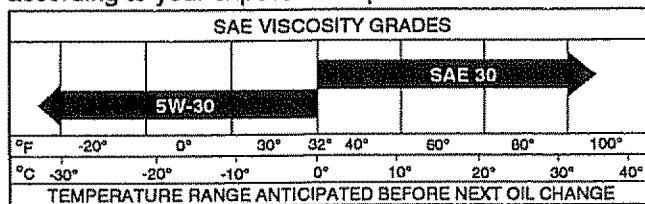

FIG. 16

NOTE: Although multi-viscosity oils (5W-30, 10W-30, etc.) improve starting in cold weather, these multi-viscosity oils will result in increased oil consumption when used above 32°F (0°C). Check your engine oil level more frequently to avoid possible engine damage from running low on oil.

Change the oil after the first two hours of operation and every 25 hours thereafter or at least once a year if the tiller is not used for 25 hours in one year.

Check the crankcase oil level before starting the engine and after each five (5) hours of continuous use. Add SAE 30 motor oil or equivalent. Tighten oil filler plug securely each time you check the oil level.

TO CHANGE ENGINE OIL (See Figs. 16 and 17)

Determine temperature range expected before oil change. All oil must meet API service classification SG.

- Be sure tiller is on level surface.
- Oil will drain more freely when warm.
- Catch oil in a suitable container.
- Remove drain plug.
- Tip tiller forward to drain oil.
- After oil has drained completely, replace oil drain plug and tighten securely.
- Remove oil filler plug. Be careful not to allow dirt to enter the engine.
- Refill engine with oil. See "CHECK ENGINE OIL LEVEL" in the Operation section of this manual.

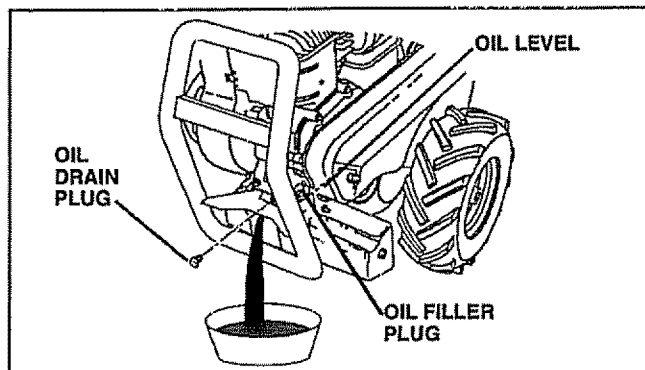

FIG. 17

AIR CLEANER (See Fig. 18)

Service air cleaner cartridge every twenty-five hours, more often if engine is used in very dusty conditions.

- Loosen air cleaner screws, one on each side of cover.
- Remove air cleaner cover.
- Carefully remove air cleaner cartridge. Be careful. Do not allow dirt or debris to fall into carburetor.
- Clean by tapping gently on a flat surface.
- If very dirty, replace or wash in a nonsudsing detergent and warm water solution. Rinse thoroughly with water flowing from mesh side until water is clear. Allow cartridge to stand and air dry thoroughly before using.
- Clean and replace cover. Tighten screws securely.



CAUTION: Petroleum solvents, such as kerosene, are not to be used to clean cartridge. They may cause deterioration of the cartridge. Do not oil cartridge. Do not use pressurized air to clean or dry cartridge.

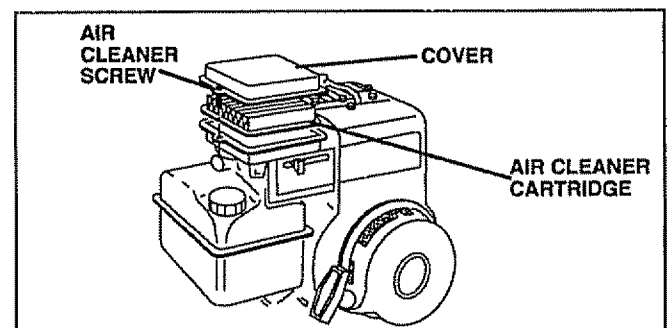

FIG. 18

COOLING SYSTEM (See Fig. 19)

Your engine is air cooled. For proper engine performance and long life keep your engine clean.

- Clean air screen frequently using a stiff-bristled brush.
- Remove blower housing and clean as necessary.
- Keep cylinder fins free of dirt and chaff.

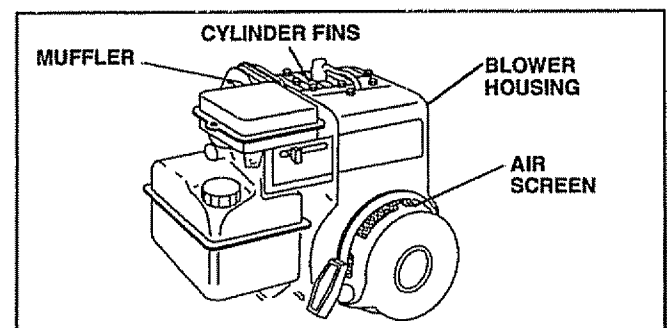

FIG. 19

CUSTOMER RESPONSIBILITIES

MUFFLER

Do not operate tiller without muffler. Do not tamper with exhaust system. Damaged mufflers or spark arresters could create a fire hazard. Inspect periodically and replace if necessary. If your engine is equipped with a spark arrester screen assembly, remove every 50 hours for cleaning and inspection. Replace if damaged.

SPARK PLUG

Replace spark plugs at the beginning of each tilling season or after every 50 hours of use, whichever comes first. Spark plug type and gap setting is shown in "PRODUCT SPECIFICATIONS" on page 3 of this manual.

TRANSMISSION

Your transmission is sealed and will only require lubrication if serviced.

CLEANING

- Clean engine, wheels, finish, etc. of all foreign matter.
- Keep finished surfaces and wheels free of all gasoline, oil, etc.
- Protect painted surfaces with automotive type wax.

We do not recommend using a garden hose to clean your unit unless the muffler, air filter and carburetor are covered to keep water out. Water in engine can result in a shortened engine life.

SERVICE AND ADJUSTMENTS



CAUTION: Disconnect spark plug wire from spark plug and place wire where it cannot come into contact with plug.

TILLER

TO ADJUST HANDLE HEIGHT (See Fig. 20)

Select handle height best suited for your tilling conditions. Handle height will be different when tiller digs into soil.

- First loosen handle lock lever.
- Handle can be positioned at different settings between "HIGH" and "LOW" positions.
- Retighten handle lock lever securely after adjusting.

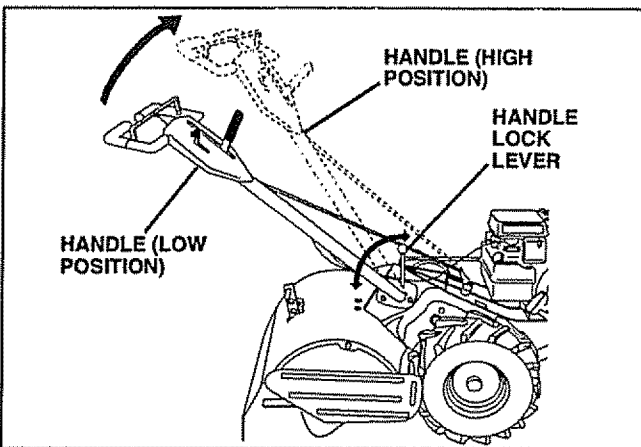

FIG. 20

TIRE CARE



CAUTION: When mounting tires, unless beads are seated, overinflation can cause an explosion.

- Maintain 20 pounds of tire pressure. If tire pressures are not equal, tiller will pull to one side.
- Keep tires free of gasoline or oil which can damage rubber.

TO REMOVE WHEEL (See Fig. 21)

- Place blocks under transmission to keep tiller from tipping.
- Remove outer side shield by removing nuts "A" and "B".
- Remove inner side shield by removing nuts "C" and "D".
- Remove hairpin clip and clevis pin from wheel.
- Remove wheel and tire.
- Repair tire and reassemble.

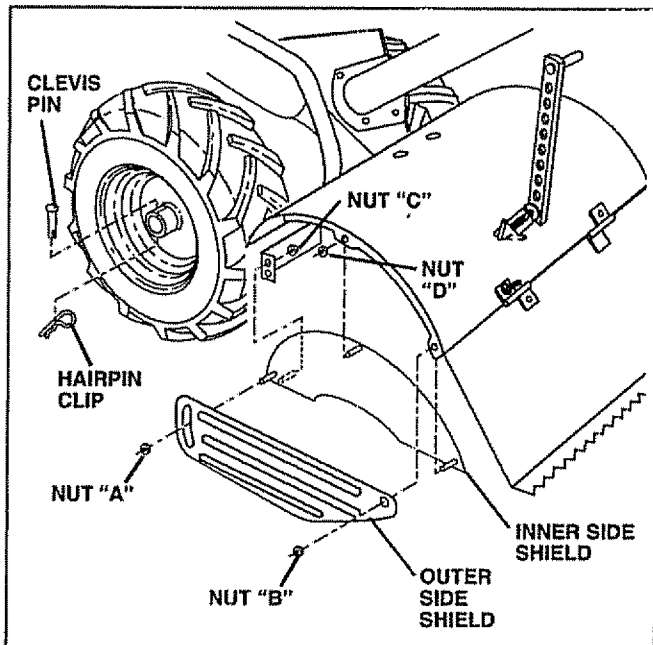

FIG. 21

SERVICE AND ADJUSTMENTS

TO REMOVE BELT GUARD (See Fig. 22)

- Remove L.H. inner and outer side shields (See "TO REMOVE WHEEL" in this section of this manual).
- Remove hairpin clip and clevis pin from left wheel. Pull wheel out from tiller about 1 inch.
- Remove two (2) cap nuts and washers from side of belt guard.
- Remove hex nut and washer from bottom of belt guard (located behind wheel).
- Pull belt guard out and away from unit.
- Replace belt guard by reversing above procedure.

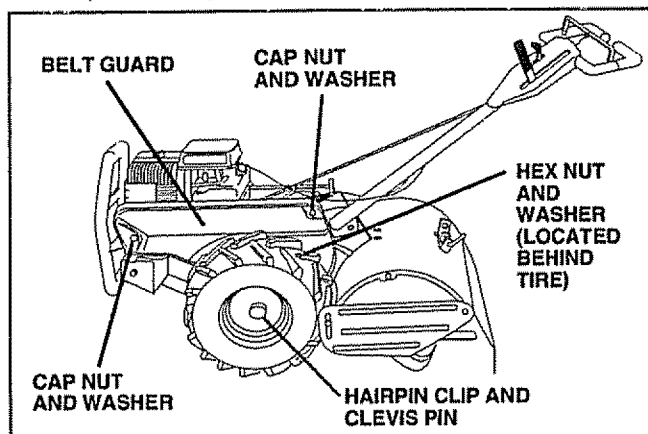

FIG. 22

TO REPLACE GROUND DRIVE BELT (See Figs. 22 and 23)

- Remove belt guard. (See "TO REMOVE BELT GUARD" in this section of this manual).
- Loosen belt guides "A" and "B" and also nuts "C" and "D".
- Remove old belt by slipping from engine pulley first.
- Place new belt in groove of transmission pulley and into engine pulley. BELT MUST BE IN GROOVE ON TOP OF IDLER PULLEY. NOTE POSITION OF BELT TO GUIDES.
- Tighten belt guides "A" and "B" and nuts "C" and "D".
- Check belt adjustment as described below.
- Replace belt guard.
- Reposition wheel and replace clevis pin and hairpin clip.
- Replace inner and outer side shields.

GROUND DRIVE BELT ADJUSTMENT (See Fig. 23)

For proper belt tension, the extension spring should have about 5/8 inch stretch when drive control bar is in "ENGAGED" position. This tension can be attained as follows:

- Loosen cable clip screw securing the drive control cable.
- Slide cable forward for less tension and rearward for more tension until about 5/8 inch stretch is obtained while the drive control bar is engaged.
- Tighten cable clip screw securely.

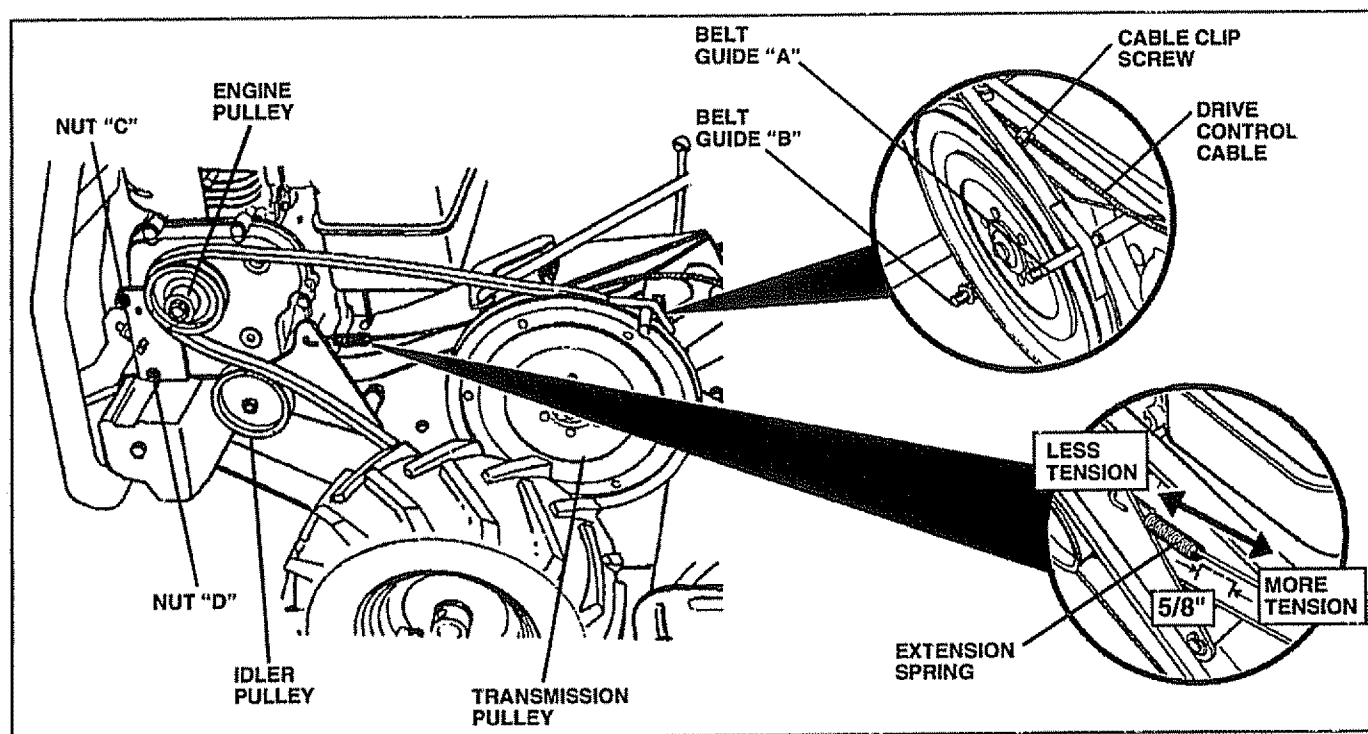

FIG. 23

SERVICE AND ADJUSTMENTS

TINE REPLACEMENT (See Figs. 24, 25 and 26)



CAUTION: Tines are sharp. Wear gloves or other protection when handling tines.

A badly worn tine causes your tiller to work harder and dig more shallow. Most important, worn tines cannot chop and shred organic matter as effectively nor bury it as deeply as good tines. A tine this worn needs to be replaced.

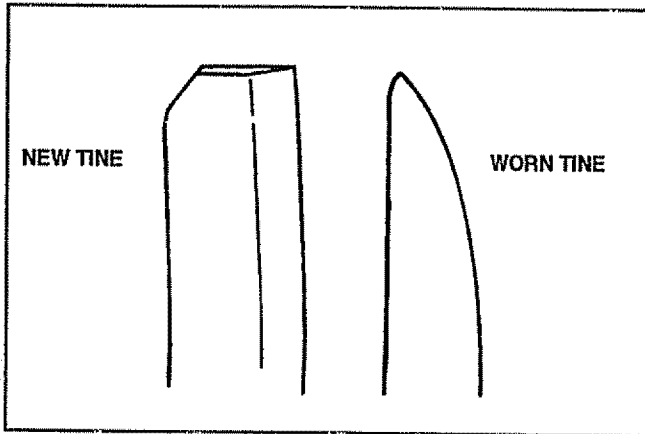

FIG. 24

- To maintain the superb tilling performance of this machine the tines should be checked for sharpness, wear, and bending, particularly the tines which are next to the transmission. If the gap between the tines exceeds 3-1/2 inches they should be replaced or straightened as necessary.
- New tines should be assembled as shown in Fig. 26. Sharpened tine edges will rotate rearward from above.

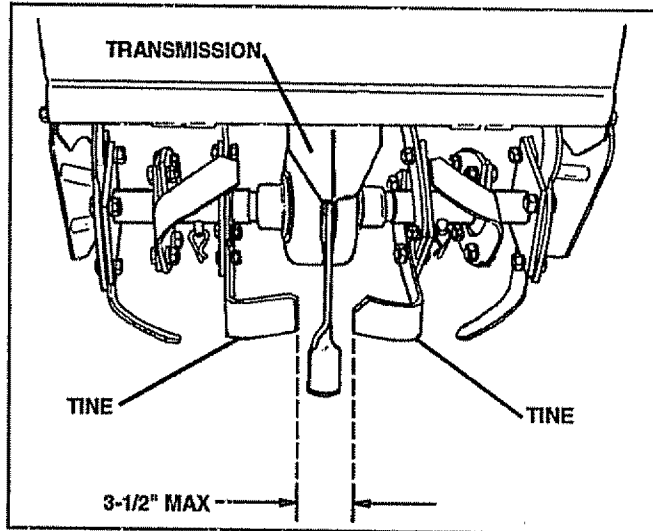

FIG. 25

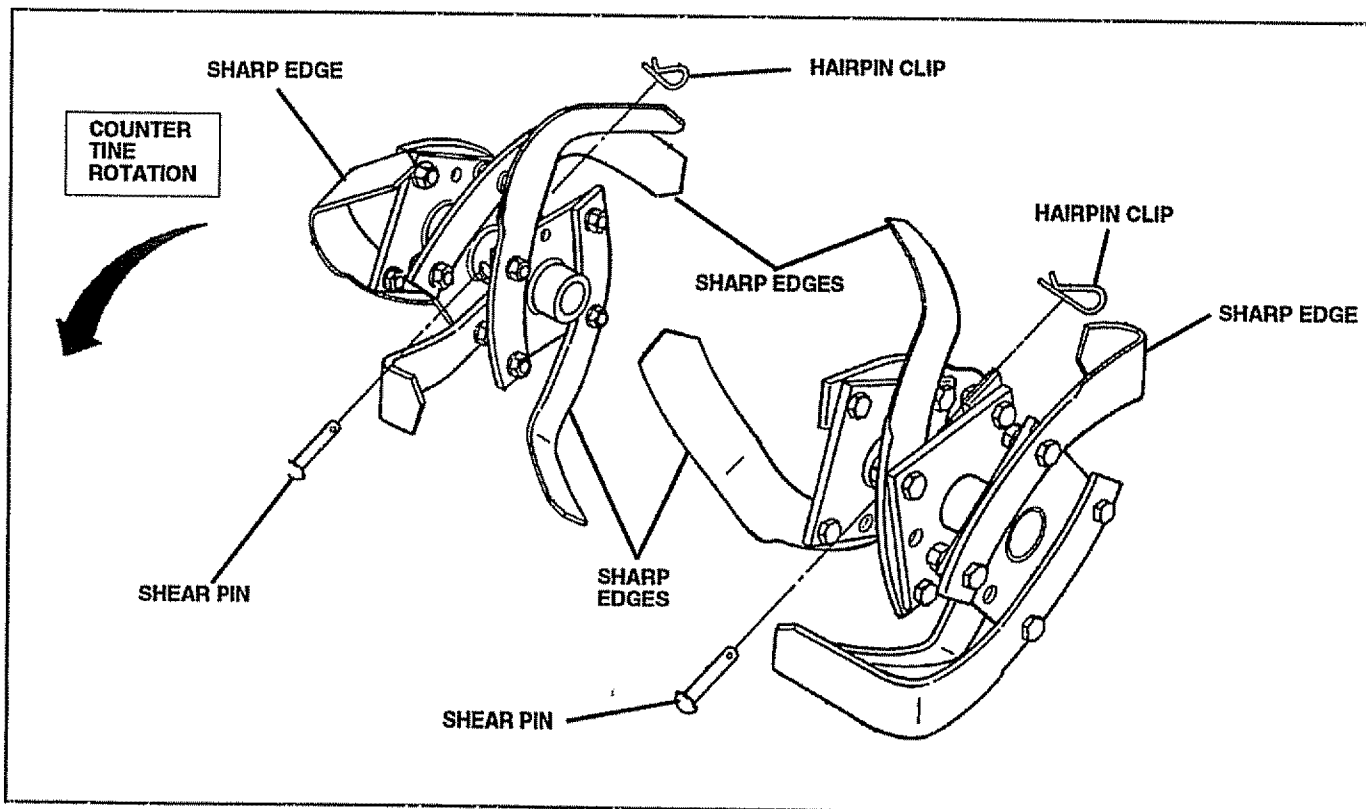

FIG. 26

SERVICE AND ADJUSTMENTS

ENGINE

TO ADJUST THROTTLE CONTROL CABLE (See Fig. 27)

- Loosen cable clamp screw to allow cable to move.
- Move throttle control lever on upper handle to "FAST" position.
- Pull throttle cable out until engine bellcrank is back as far as it will go.
- Hold cable in this position and tighten clamp screw securely.

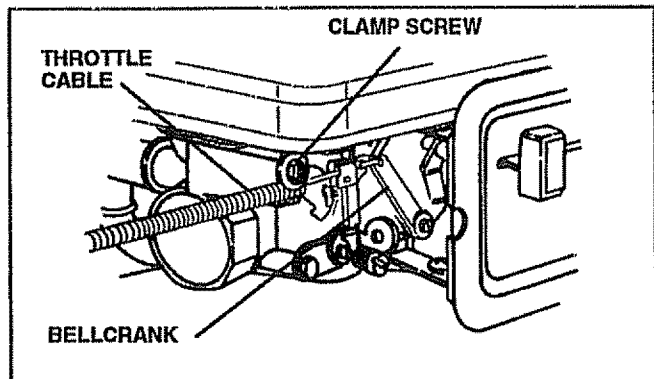

FIG. 27

TO ADJUST CARBURETOR (See Fig. 28)

The carburetor has a high speed jet and has been preset at the factory and adjustment should not be necessary. However, minor adjustments may be required to compensate for differences in fuel, temperature, altitude or load. If the carburetor does need adjustment, proceed as follows.

In general, turning the idle needle valve in (clockwise) decreases the supply of fuel to the engine giving a leaner fuel/air mixture. Turning the needle valve out (counterclockwise) increases the supply of fuel to the engine giving a richer fuel/air mixture.

IMPORTANT: DAMAGE TO THE NEEDLES AND THE SEATS IN CARBURETOR MAY RESULT IF SCREWS ARE TURNED IN TOO TIGHT.

PRELIMINARY SETTING

- Air cleaner assembly must be assembled to the carburetor when making carburetor adjustments.
- Be sure the throttle control cable is adjusted properly (see above).
- With engine off, turn idle needle valve in (clockwise) closing it finger tight and then turn valve out (counterclockwise) 1-1/2 turns.

FINAL SETTING

- Start engine and allow to warm for five minutes. Make final adjustments with engine running at idle and drive control bar in "DISENGAGED" position.
- With throttle control lever in "SLOW" position, turn idle needle valve in (clockwise) until engine begins to die then turn out (counterclockwise) until engine runs rough. Turn valve to a point midway between those two positions.

IDLE RPM ADJUSTMENT

- To adjust idle RPM, rotate throttle linkage counterclockwise and hold against stop while adjusting idle speed adjusting screw to obtain 1750 RPM. Release throttle linkage.

ACCELERATION TEST

- Move throttle control lever from "SLOW" to "FAST" position. If engine hesitates or dies, turn needle valve out (counterclockwise) 1/8 turn. Repeat test and continue to adjust, if necessary, until engine accelerates smoothly.

High speed stop is factory adjusted. Do not adjust or damage may result.

IMPORTANT: NEVER TAMPER WITH THE ENGINE GOVERNOR, WHICH IS FACTORY SET FOR PROPER ENGINE SPEED. OVERSPEEDING THE ENGINE ABOVE THE FACTORY HIGH SPEED SETTING CAN BE DANGEROUS. IF YOU THINK THE ENGINE-GOVERNED HIGH SPEED NEEDS ADJUSTING, CONTACT YOUR NEAREST SEARS SERVICE CENTER, WHICH HAS PROPER EQUIPMENT AND EXPERIENCE TO MAKE ANY NECESSARY ADJUSTMENTS.

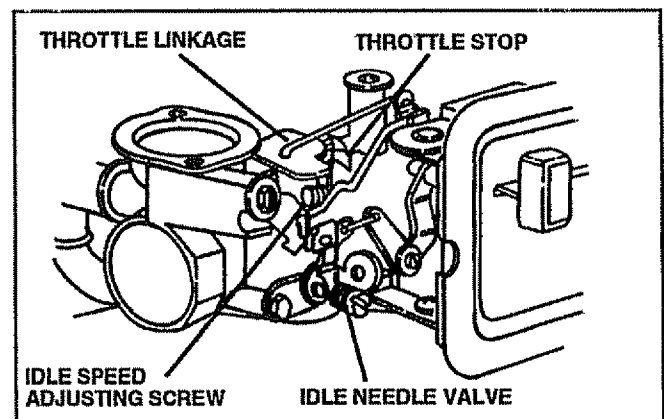

FIG. 28

STORAGE

Immediately prepare your tiller for storage at the end of the season or if the unit will not be used for 30 days or more.



CAUTION: Never store the tiller with gasoline in the tank inside a building where fumes may reach an open flame or spark. Allow the engine to cool before storing in any enclosure.

TILLER

- Clean entire tiller (See "CLEANING" in the Customer Responsibilities section of this manual).
- Inspect and replace belts, if necessary (See belt replacement instructions in the Service and Adjustments section of this manual).
- Lubricate as shown in the Customer Responsibilities section of this manual.
- Be sure that all nuts, bolts and screws are securely fastened. Inspect moving parts for damage, breakage and wear. Replace if necessary.
- Touch up all rusted or chipped paint surfaces; sand lightly before painting.

ENGINE

FUEL SYSTEM

IMPORTANT: IT IS IMPORTANT TO PREVENT GUM DEPOSITS FROM FORMING IN ESSENTIAL FUEL SYSTEM PARTS SUCH AS THE CARBURETOR, FUEL FILTER, FUEL HOSE, OR TANK DURING STORAGE. ALSO, EXPERIENCE INDICATES THAT ALCOHOL BLENDED FUELS (CALLED GASOHOL OR USING ETHANOL OR METHANOL) CAN ATTRACT MOISTURE WHICH LEADS TO SEPARATION AND FORMATION OF ACIDS DURING STORAGE. ACIDIC GAS CAN DAMAGE THE FUEL SYSTEM OF AN ENGINE WHILE IN STORAGE.

- Drain the fuel tank.
- Start the engine and let it run until the fuel lines and carburetor are empty.
- Never use engine or carburetor cleaner products in the fuel tank or permanent damage may occur.
- Use fresh fuel next season.

NOTE: Fuel stabilizer is an acceptable alternative in minimizing the formation of fuel gum deposits during storage. Add stabilizer to gasoline in fuel tank or storage container. Always follow the mix ratio found on stabilizer container. Run engine at least 10 minutes after adding stabilizer to allow the stabilizer to reach the carburetor. Do not drain the gas tank and carburetor if using fuel stabilizer.

ENGINE OIL

Drain oil (with engine warm) and replace with clean oil. (See "ENGINE" in the Customer Responsibilities section of this manual).

CYLINDERS

- Remove spark plug.
- Pour 1 ounce (29 ml) of oil through spark plug hole into cylinder.
- Pull starter handle slowly several times to distribute oil.
- Replace with new spark plug.

OTHER

- Do not store gasoline from one season to another.
- Replace your gasoline can if your can starts to rust. Rust and/or dirt in your gasoline will cause problems.
- If possible, store your unit indoors and cover it to give protection from dust and dirt.
- Cover your unit with a suitable protective cover that does not retain moisture. Do not use plastic. Plastic cannot breathe which allows condensation to form and will cause your unit to rust.

IMPORTANT: NEVER COVER TILLER WHILE ENGINE AND EXHAUST AREAS ARE STILL WARM.

TROUBLESHOOTING POINTS

PROBLEM	CAUSE	CORRECTION
Will not start	<ol style="list-style-type: none"> 1. Out of fuel. 2. Engine not "CHOKED" properly. 3. Engine flooded. 4. Dirty air cleaner. 5. Water in fuel. 6. Clogged fuel tank. 7. Loose spark plug wire. 8. Bad spark plug or improper gap. 9. Carburetor out of adjustment. 	<ol style="list-style-type: none"> 1. Fill fuel tank. 2. See "TO START ENGINE" in Operation section. 3. Wait several minutes before attempting to start. 4. Clean or replace air cleaner cartridge. 5. Drain fuel tank and carburetor, and refill tank with fresh gasoline. 6. Remove fuel tank and clean. 7. Make sure spark plug wire is seated properly on plug. 8. Replace spark plug or adjust gap. 9. Make necessary adjustments.
Hard to start	<ol style="list-style-type: none"> 1. Throttle control not set properly. 2. Dirty air cleaner. 3. Bad spark plug or improper gap. 4. Stale or dirty fuel. 5. Loose spark plug wire. 6. Carburetor out of adjustment. 	<ol style="list-style-type: none"> 1. Place throttle control in "FAST" position. 2. Clean or replace air cleaner cartridge. 3. Replace spark plug or adjust gap. 4. Drain fuel tank and refill with fresh gasoline. 5. Make sure spark plug wire is seated properly on plug. 6. Make necessary adjustments.
Loss of power	<ol style="list-style-type: none"> 1. Engine is overloaded. 2. Dirty air cleaner. 3. Low oil level/dirty oil. 4. Faulty spark plug. 5. Oil in fuel. 6. Stale or dirty fuel. 7. Water in fuel. 8. Clogged fuel tank. 9. Spark plug wire loose. 10. Dirty engine air screen. 11. Dirty/clogged muffler. 12. Carburetor out of adjustment. 13. Poor compression. 	<ol style="list-style-type: none"> 1. Set depth stake for shallower tilling. 2. Clean or replace air cleaner cartridge. 3. Check oil level/change oil. 4. Clean and regap or change spark plug. 5. Drain and clean fuel tank and refill, and clean carburetor. 6. Drain fuel tank and refill with fresh gasoline. 7. Drain fuel tank and carburetor, and refill tank with fresh gasoline. 8. Remove fuel tank and clean. 9. Connect and tighten spark plug wire. 10. Clean engine air screen. 11. Clean/replace muffler. 12. Make necessary adjustments. 13. Contact an authorized Sears Service Center/Department.
Engine overheats	<ol style="list-style-type: none"> 1. Low oil level/dirty oil. 2. Dirty engine air screen. 3. Dirty engine. 4. Partially plugged muffler. 5. Improper carburetor adjustment. 	<ol style="list-style-type: none"> 1. Check oil level/change oil. 2. Clean engine air screen. 3. Clean cylinder fins, air screen, and muffler area. 4. Remove and clean muffler. 5. Adjust carburetor to richer position.
Excessive bounce/ difficult handling	<ol style="list-style-type: none"> 1. Ground too dry and hard. 	<ol style="list-style-type: none"> 1. Moisten ground or wait for more favorable soil conditions.
Soil balls up or clumps	<ol style="list-style-type: none"> 1. Ground too wet. 	<ol style="list-style-type: none"> 1. Wait for more favorable soil conditions.
Engine runs but tiller won't move	<ol style="list-style-type: none"> 1. Drive control bar is not engaged. 2. V-belt not correctly adjusted. 3. V-belt is off pulley(s). 	<ol style="list-style-type: none"> 1. Engage drive control. 2. Inspect/adjust V-belt. 3. Inspect V-belt.
Engine runs but labors when tilling	<ol style="list-style-type: none"> 1. Tilling too deep. 2. Throttle control not properly adjusted. 3. Carburetor out of adjustment. 	<ol style="list-style-type: none"> 1. Set depth stake for shallower tilling. 2. Check throttle control setting. 3. Make necessary adjustments.
Tines will not rotate	<ol style="list-style-type: none"> 1. Shear pin(s) broken. 	<ol style="list-style-type: none"> 1. Replace shear pin(s).

REPAIR PARTS

5 HP 17" TILLER -- MODEL NUMBER 917.298560

HANDLES

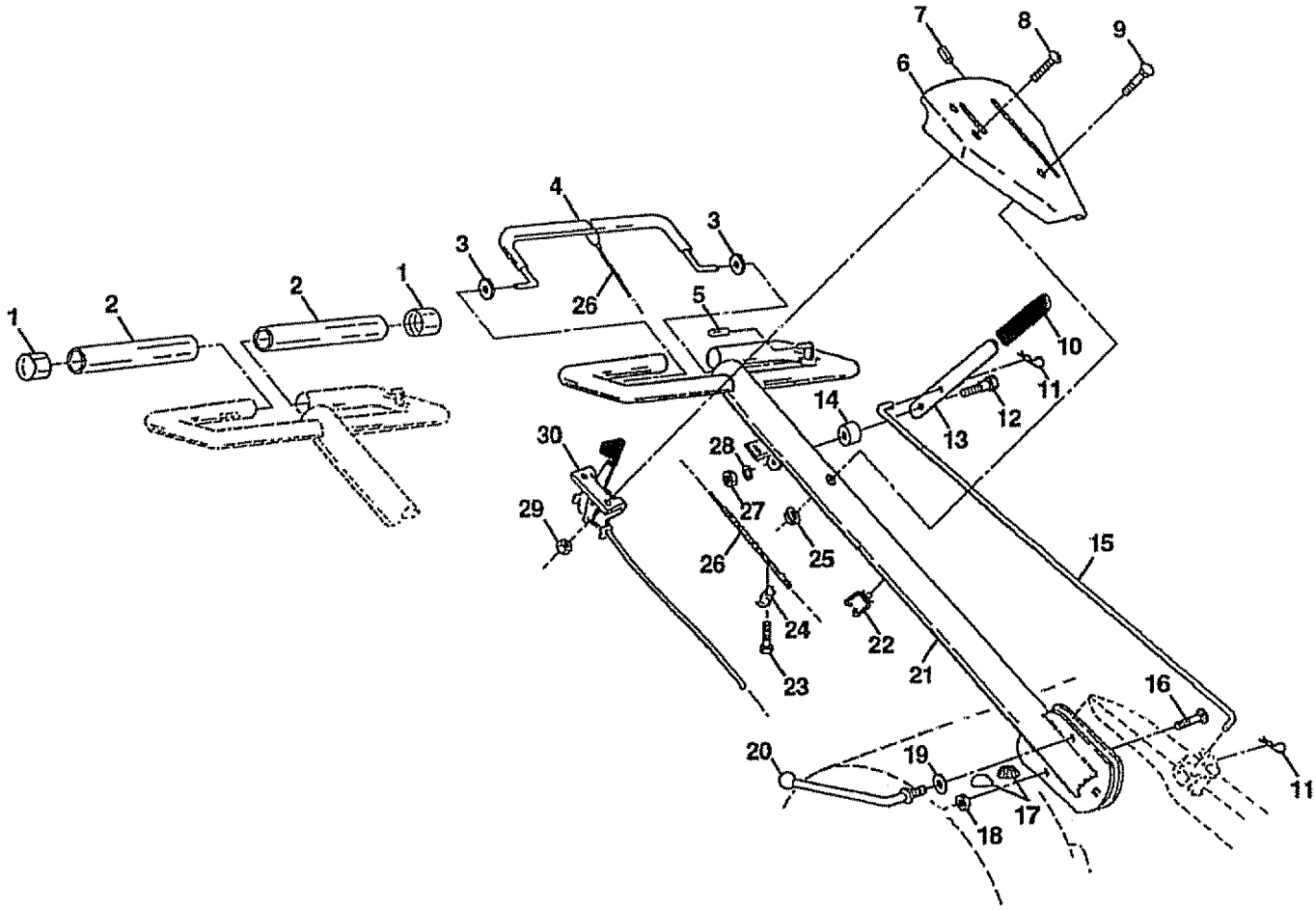

KEY NO.	PART NO.	DESCRIPTION
1	110707X	Cap, Sleeve
2	110674X	Grip, Handle
3	110673X	Grommet, Handle
4	127254X	Bar, Drive Control Assembly
5	6712J	Cap, Vinyl
6	137119	Panel, Control
7	110641X	Bushing, Split
8	STD511005	* Screw, Mach. Pan Head. C.R. #10-24 x 1/2
9	STD533125	* Bolt, Carriage 5/16-18 UNC x 2-3/8 Gr. 5
10	110646X	Handle, Grip
11	STD624003	* Clip, Hairpin
12	81328	Bolt, Shoulder
13	110741X	Handle, Shift
14	109313X	Grommet, Rubber
15	110702X	Rod, Shift
16	STD533710	* Bolt, Carriage 3/8-16 x 1 Gr. 5
17	109229X	Lock, Handle

KEY NO.	PART NO.	DESCRIPTION
18	STD541437	* Nut, Centerlock 3/8-16
19	19131611	Washer 13/32 x 1 x 11 Ga.
20	109228X	Lever, Lock, Handle
21	121213X	Handle, Assembly
22	121145X	Clip, Plastic, Cable
23	86777	Screw, Hex, Washer Hd, Slotted #10-24 x 1/2
24	9484R	Clip
25	73970500	Locknut, Hex, Flange
26	110675X	Clutch, Cable
27	STD541025	* Nut, Hex 1/4-20
28	STD551125	* Washer, Lock 1/4
29	STD541462	* Nut, Keps #10-24
30	127012X	Throttle, Control

* STANDARD HARDWARE -- PURCHASE LOCALLY

NOTE: All component dimensions given in U.S. inches.
1 inch = 25.4 mm

REPAIR PARTS

5 HP 17" TILLER -- MODEL NUMBER 917.298560

MAINFRAME, LEFT SIDE

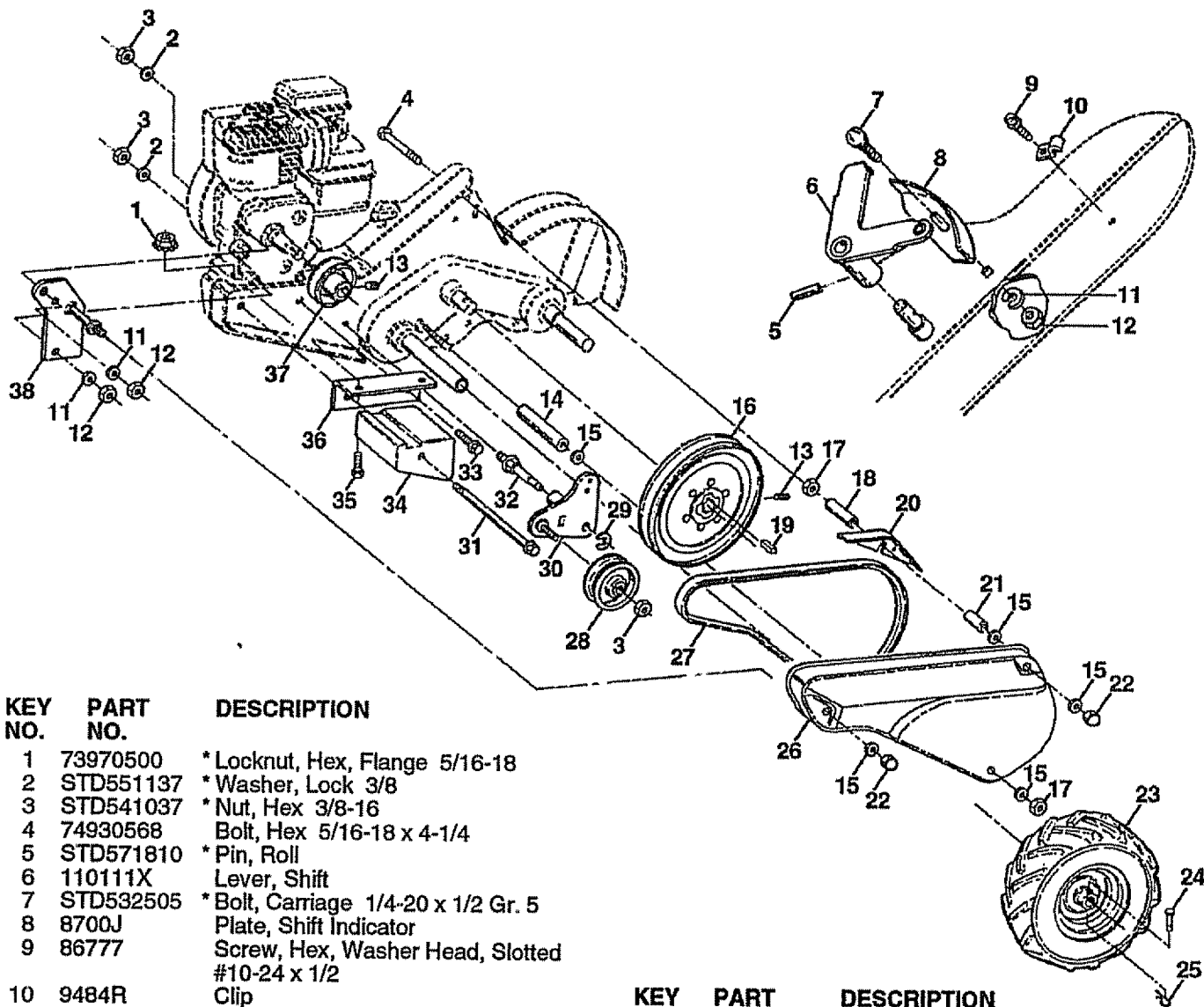

KEY NO.	PART NO.	DESCRIPTION
1	73970500	* Locknut, Hex, Flange 5/16-18
2	STD551137	* Washer, Lock 3/8
3	STD541037	* Nut, Hex 3/8-16
4	74930568	Bolt, Hex 5/16-18 x 4-1/4
5	STD571810	* Pin, Roll
6	110111X	Lever, Shift
7	STD532505	* Bolt, Carriage 1/4-20 x 1/2 Gr. 5
8	8700J	Plate, Shift Indicator
9	86777	Screw, Hex, Washer Head, Slotted #10-24 x 1/2
10	9484R	Clip
11	STD551125	* Washer, Lock 1/4
12	STD541025	* Nut, Hex 1/4-20
13	STD503103	* Screw, Set, Hex 5/16-18 x 3/8
14	120938X	Spacer, Split 0.327 x 0.42 x 2.68
15	STD551031	* Washer 11/32 x 11/16 x 16 Ga.
16	100473M	Sheave, Transmission
17	STD541031	* Nut, Hex 5/16-18
18	110651X	Spacer, Split 0.327 x 0.42 x 1.75
19	2649M	Key, Square 3/16 x 1-1/8
20	110653X	Guard, Pinch Point
21	131691	Spacer, Split 0.327 x 0.42 x 1.627
22	104214X	Nut, Cap 5/16-18
23	5015J	Tire
	128952	Rim
	795R	Tire Valve
24	126875X	Rivet, Drilled
25	STD624003	* Clip, Hairpin
26	131159X459	Guard, Belt
27	132801	Belt, V

KEY NO.	PART NO.	DESCRIPTION
28	104679X	Pulley, Idler
29	12000032	Ring, Klip
30	105611X	Bracket, Idler
31	102384X	Bolt, Hex 5/16-16 x 12
32	102141X	Shaft, Idler Arm
33	STD523710	* Bolt, Hex 3/8-16 x 1
34	102383X	Counterweight, L.H.
35	74760532	Bolt, Hex 5/16-18 x 2
36	102331X	Bracket, Reinforcement, L.H.
37	130812	Sheave, Engine
38	131556	Bracket, Guard Belt

*STANDARD HARDWARE -- PURCHASE LOCALLY

NOTE: All component dimensions given in U.S. inches.
1 inch = 25.4 mm

REPAIR PARTS

5 HP 17" TILLER - - MODEL NUMBER 917.298560

MAINFRAME, RIGHT SIDE

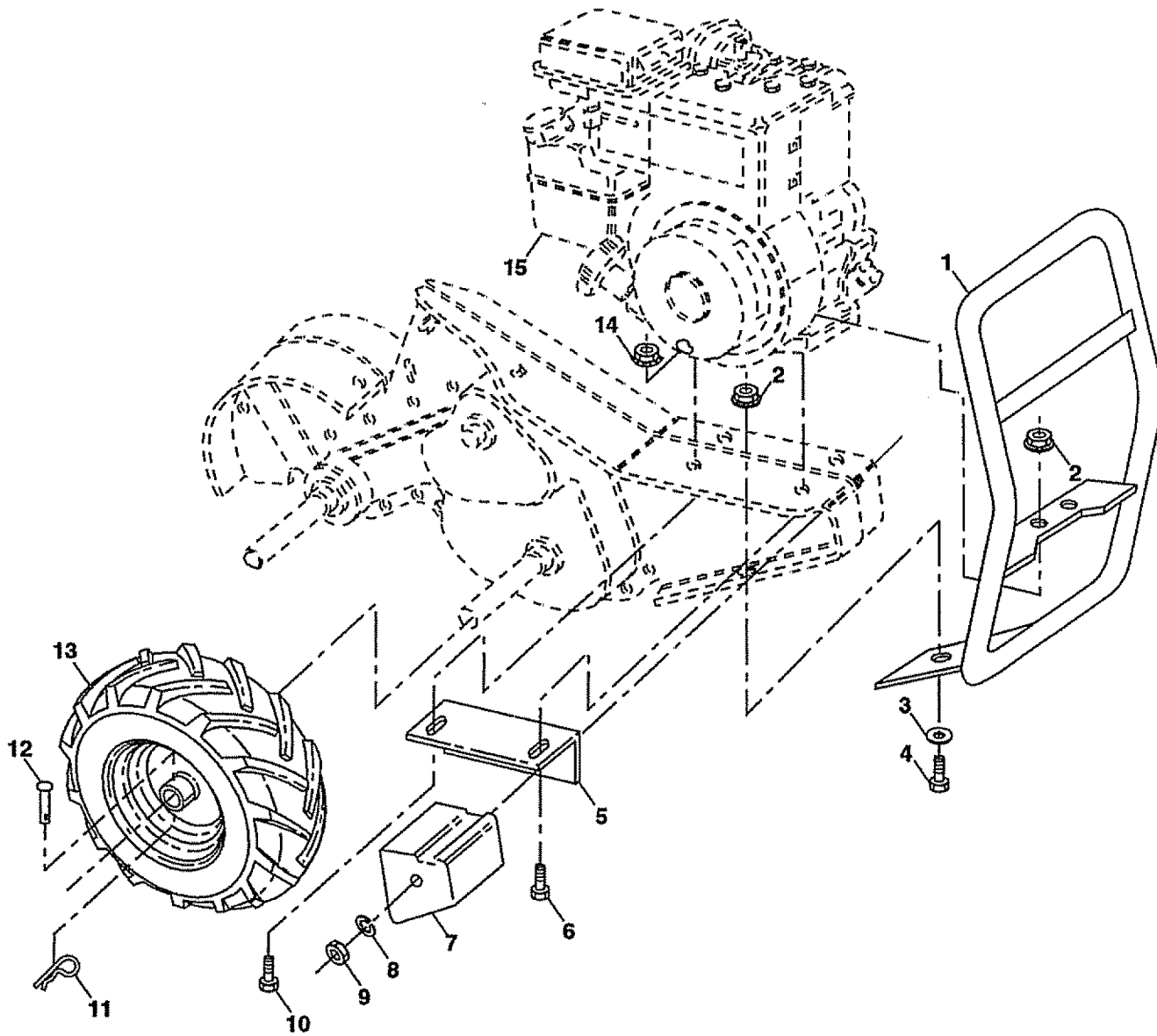

KEY NO.	PART NO.	DESCRIPTION
1	124551X	Bumper
2	73970500	Locknut, Hex, Flange 5/16-18
3	STD551031	* Washer 11/32 x 11/16 x 16 Ga.
4	74760512	Bolt, Hex 5/16-18 x 3/4
5	102332X	Bracket, Reinforcement
6	74760532	Bolt, Hex 5/16-18 x 2
7	102173X	Counter Weight, R.H.
8	STD551137	* Washer, Lock 3/8
9	STD541037	* Nut, Hex 3/8-16
10	74760524	Bolt, Hex 5/16-18 x 1-1/2
11	STD624003	* Clip, Hairpin

KEY NO.	PART NO.	DESCRIPTION
12	126875X	Rivet, Drilled
13	5015J	Tire
	128952	Rim
	795R	Tire Valve
14	STD541431	* Nut, Keps 5/16-18
15	137264	Engine, Briggs & Stratton Model No. 135202, Type No. 0145-01

* STANDARD HARDWARE - - PURCHASE LOCALLY

NOTE: All component dimensions given in U.S.inches.
1 inch = 25.4 mm

REPAIR PARTS

5 HP 17" TILLER - - MODEL NUMBER 917.298560

TRANSMISSION

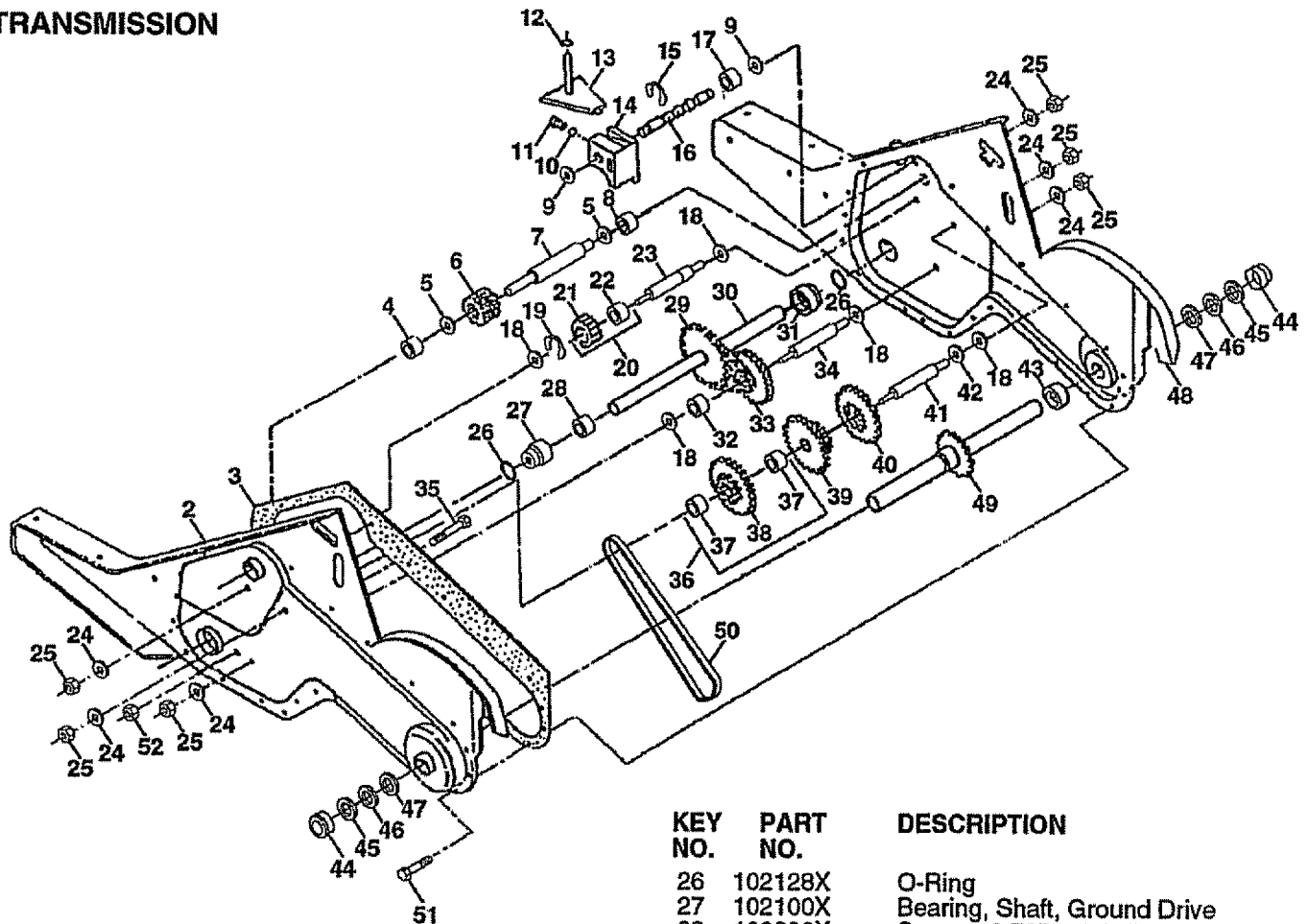

KEY NO.	PART NO.	DESCRIPTION
1	137409	Transmission Assembly (Includes Key Nos. 2-52)
2	121147X	Gearcase, L.H. w/Bearing (Includes Key No. 4)
3	106211X	Gasket, Gearcase
4	5020J	Bearing, Needle
5	1370H	Washer, Thrust 5/8 x 1.10 x 1/32
6	102113X	Pinion, Input
7	102110X	Shaft, Input
8	4895H	Bearing, Needle
9	102136X	Washer, Seal
10	7392M	Ball, Steel
11	100371K	Spring, Shift, Fork
12	106160X	O-Ring
13	102107X	Arm, Shift
14	8353J	Fork, Shift
15	12000039	Ring, Klip
16	102109X	Shaft, Shift
17	104159X	Spacer, Split
18	4358J	Washer
19	12000040	Ring, Klip
20	102114X	Gear, Assembly, Reverse Idler (Includes Key Nos. 21 and 22)
21	102115X	Gear, Reverse Idler
22	6803J	Bearing, Needle
23	102111X	Shaft, Reverse Idler
24	STD551143	* Washer, Lock 7/16
25	STD541143	* Nut, Hex 7/16-20

KEY NO.	PART NO.	DESCRIPTION
26	102128X	O-Ring
27	102100X	Bearing, Shaft, Ground Drive
28	106390X	Spacer 0.765 x 1.125 x 1.23
29	102134X	Chain #35-50 Pitch
30	124458X	Ground Shaft Assembly
31	102106X	Bearing, Shaft, Ground Drive
32	106388X	Spacer 0.70 x 1.00 x 1.150
33	102121X	Sprocket and Gear Assembly
34	102112X	Shaft, Reduction (2nd)
35	102101X	Screw, Whiz, Lock 5/16-18 x 3-1/2
36	137300	Sprocket Assembly w/Bearing (Includes Key Nos. 37 and 38)
37	4422J	Bearing, Needle
38	137301	Sprocket, Tine
39	105345X	Gear, Cluster, Red 1st & 2nd
40	105346X	Gear, Reverse
41	8358J	Shaft, Reduction (1st)
42	4220R	Washer, Thrust
43	106146X	Spacer 1.01 x 1.75 x 0.760
44	9672R	Cup, Formed
45	102144X	Ring, Spiral
46	9676R	Seal, Ring, Rubber
47	9674R	Seal, Oil
48	121745X	Gearcase, R.H. w/Bearing (Includes Key No. 8)
49	132688	Shaft, Tine
50	106147X	Chain, Roller #50-50 Pitch
51	17580408	Screw 1/4-20 x 1/2
52	STD541031	* Nut, Hex 5/16-18
--	6066J	Grease, Plastilube #1

* STANDARD HARDWARE - - PURCHASE LOCALLY

24 NOTE: All component dimensions given in U.S. inches.
1 inch = 25.4 mm

REPAIR PARTS

5 HP 17" TILLER - - MODEL NUMBER 917.298560

TINE SHIELD

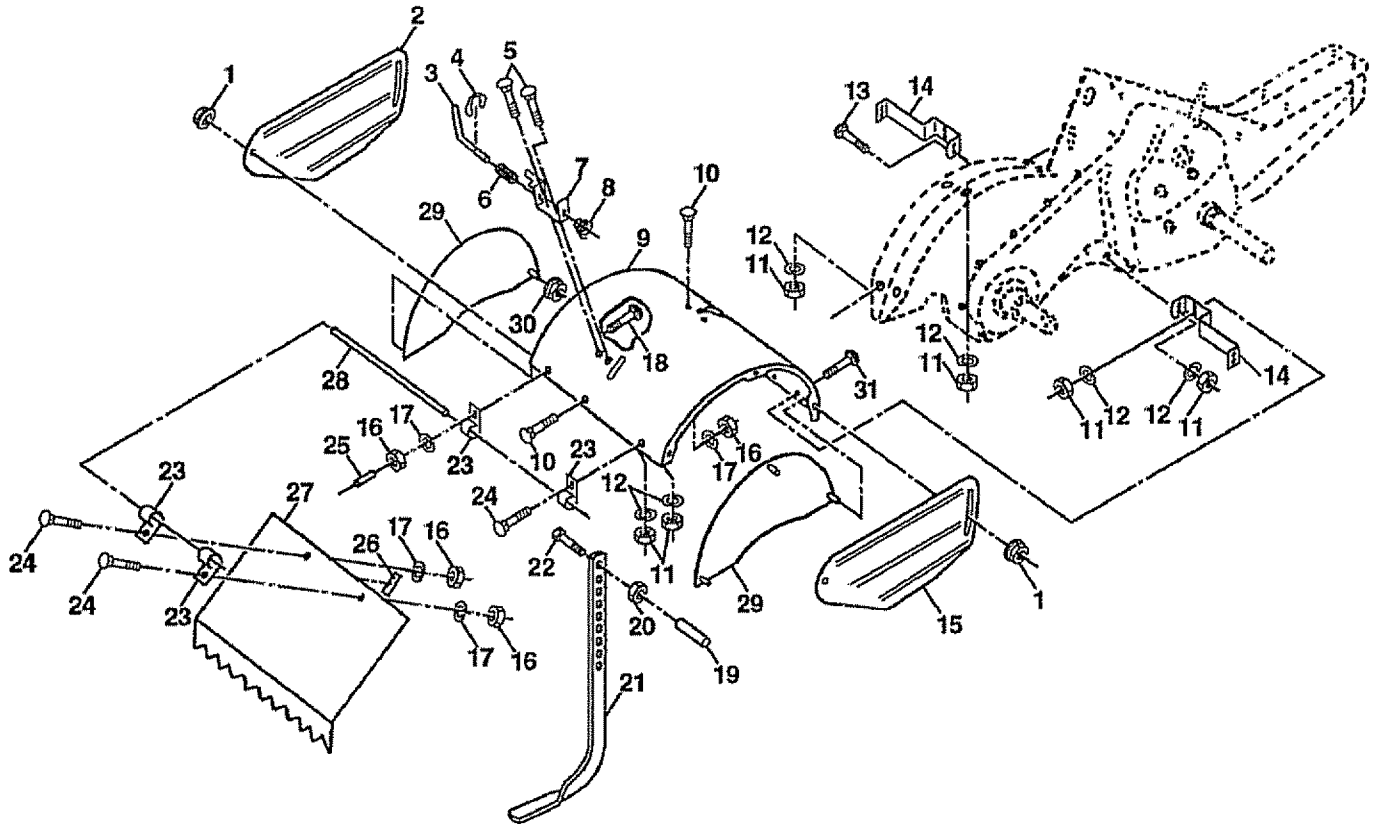

KEY NO.	PART NO.	DESCRIPTION
1	98000129	Nut, Flange 5/16-18
2	104086X459	Shield, Side, Outer L. H.
3	8393J	Pin, Stake, Depth
4	12000036	Ring, Klip
5	72110508	Bolt, Carriage 5/16-18 x 1
6	8394J	Spring
7	8392J	Bracket, Latch
8	109230X	Spring, Depth Stake
9	124289X459	Shield, Tine
10	STD533107	* Bolt, Carriage 5/16-18 x 3/4 Gr 5
11	STD541031	* Nut, Hex 5/16-18
12	STD551131	* Washer, Lock 5/16
13	72110510	Bolt, Carriage 5/16-18 x 1-1/4
14	124311X	Bracket, Shield Tine
15	104101X459	Shield, Side, Outer R.H.
16	STD541025	* Nut, Hex 1/4-20
17	STD551125	* Washer, Lock 1/4
18	STD532512	* Bolt, Carriage 1/4-20 x 1-1/4 Gr. 5

KEY NO.	PART NO.	DESCRIPTION
19	102701X	Grip
20	STD541037	* Nut, Hex 3/8-16
21	102156X	Stake, Depth
22	74930632	Bolt, Hex 3/8-16 x 2
23	4440J	Hinge
24	STD532505	* Bolt, Carriage 1/4-20 x 1/2 Gr. 5
25	6712J	Cap, Vinyl
26	109227X	Pad, Idler
27	102695X459	Shield, Leveling
28	120588X	Pin, Hinge
29	124309X459	Shield, Side
30	73970500	Locknut, Hex, Flange
31	STD533110	* Bolt, Carriage 5/16-18 x 1 Gr. 5

* STANDARD HARDWARE - - PURCHASE LOCALLY
 NOTE: All component dimensions given in U.S. inches.
 1 inch = 25.4 mm

REPAIR PARTS

5 HP 17" TILLER - - MODEL NUMBER 917.298560

TINE ASSEMBLY

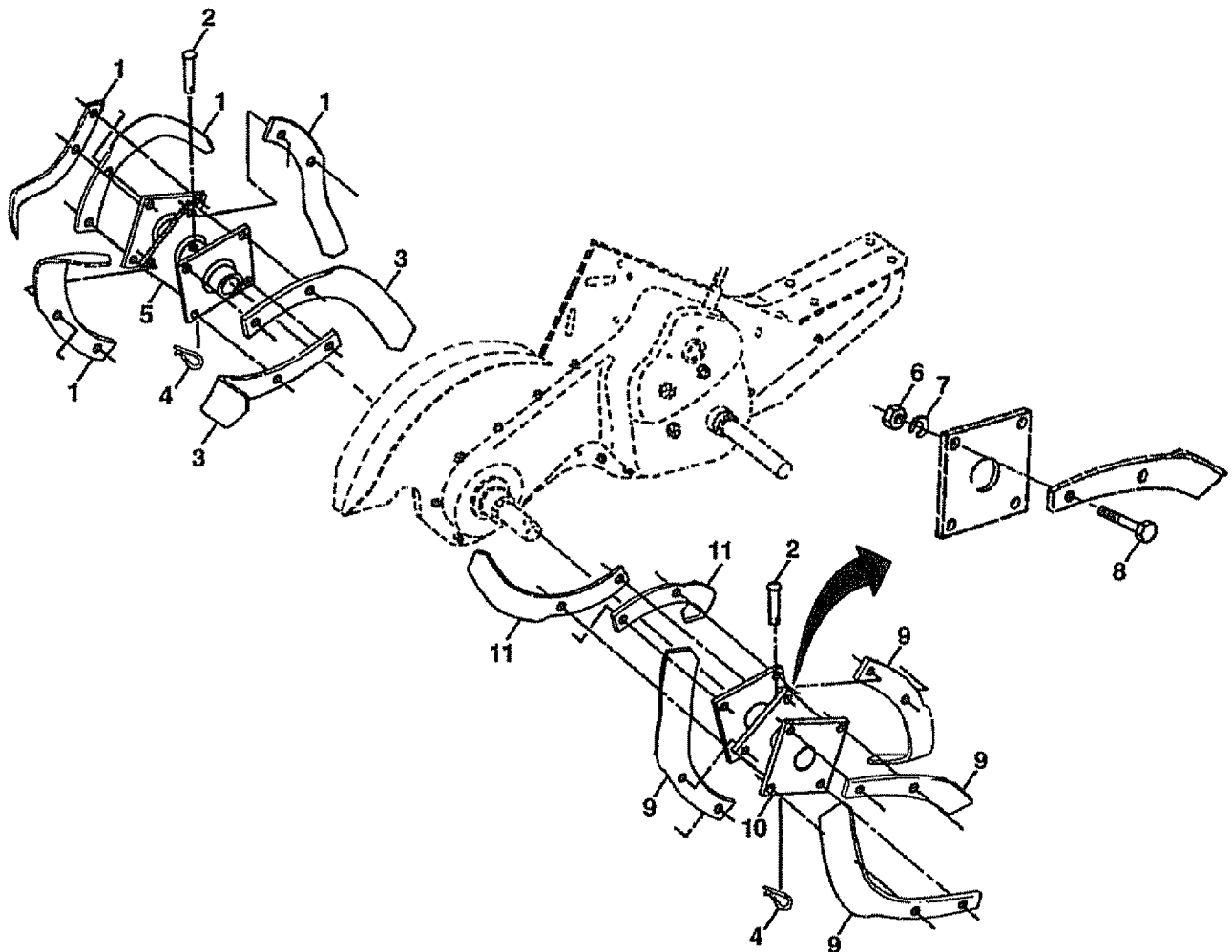

KEY NO.	PART NO.	DESCRIPTION
1	4459J	Tine, Outer, L.H.
2	132673	Pin, Shear
3	6554J	Tine, Inner, L.H.
4	STD624008	* Clip, Hairpin
5	132727	Assembly, Hub and Plate, L.H.
6	73610600	Nut, Hex 3/8-24
7	STD551137	* Washer, Lock 3/8

KEY NO.	PART NO.	DESCRIPTION
8	74610616	Bolt, Hex 3/8-24 x 1
9	4460J	Tine, Outer, R.H.
10	132728	Assembly, Hub and Plate, R.H.
11	6555J	Tine, Inner, R.H.

* STANDARD HARDWARE - - PURCHASE LOCALLY

NOTE: All component dimensions given in U.S. inches.
1 inch = 25.4 mm

REPAIR PARTS

5 HP 17" TILLER -- MODEL NUMBER 917.298560

DECALS

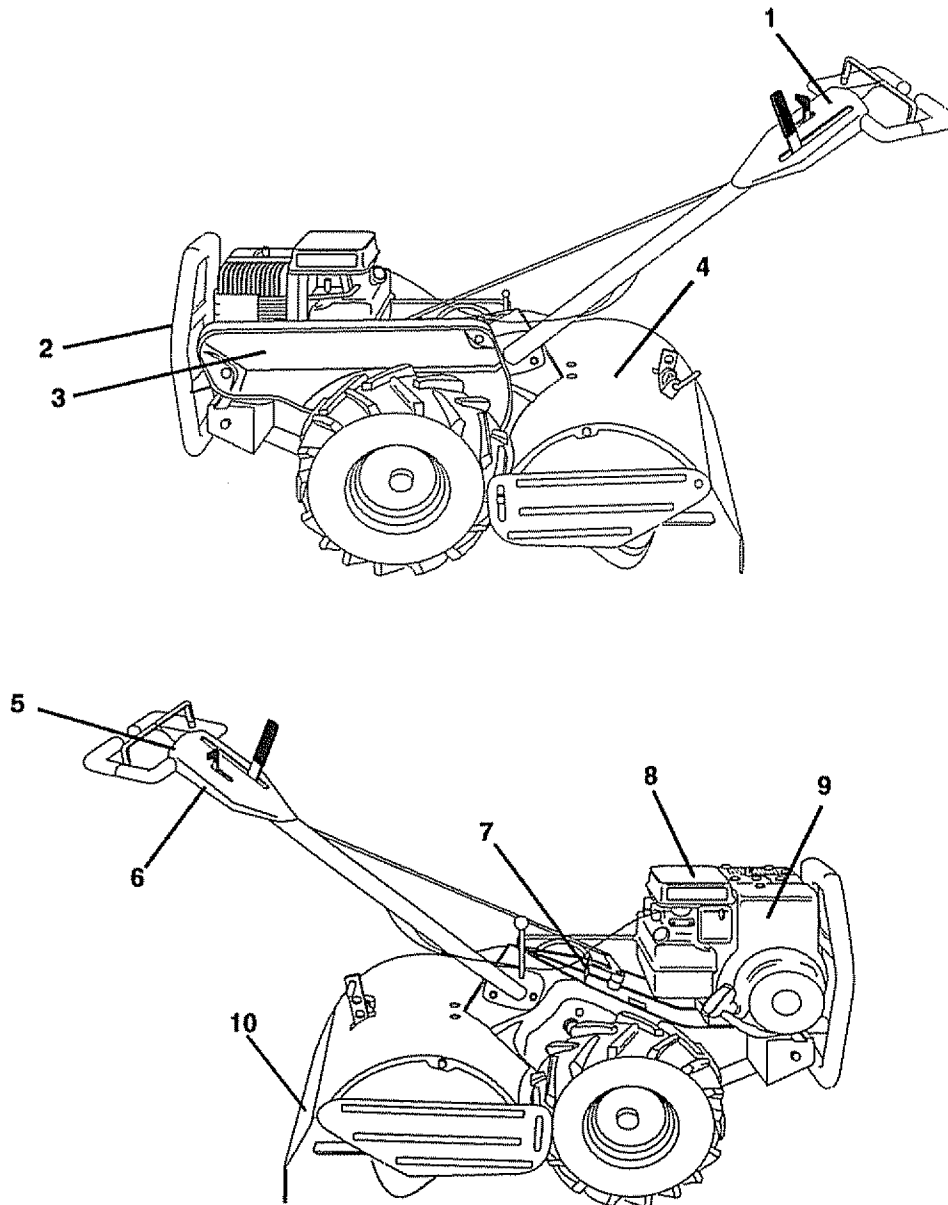

KEY NO.	PART NO.	DESCRIPTION
1	137740	Decal, Logo
2	124552X	Decal, Logo
3	132252	Decal, Logo
4	132253	Decal, Logo
5	137538	Decal, Caution, Drive Control
6	120431X	Decal, Hand Placement
7	102180X	Decal, Shift Indicator
8	110719X	Decal, Operation and Lubrication
9	132402	Decal, HP
10	120075X	Decal, Warning, Rotating Tines
--	137921	Manual, Owner's (English)

REPAIR PARTS

5 HP 17" TILLER -- MODEL NUMBER 917.298560

ENGINE, BRIGGS & STRATTON -- MODEL NUMBER 135202, TYPE NO. 0145-01

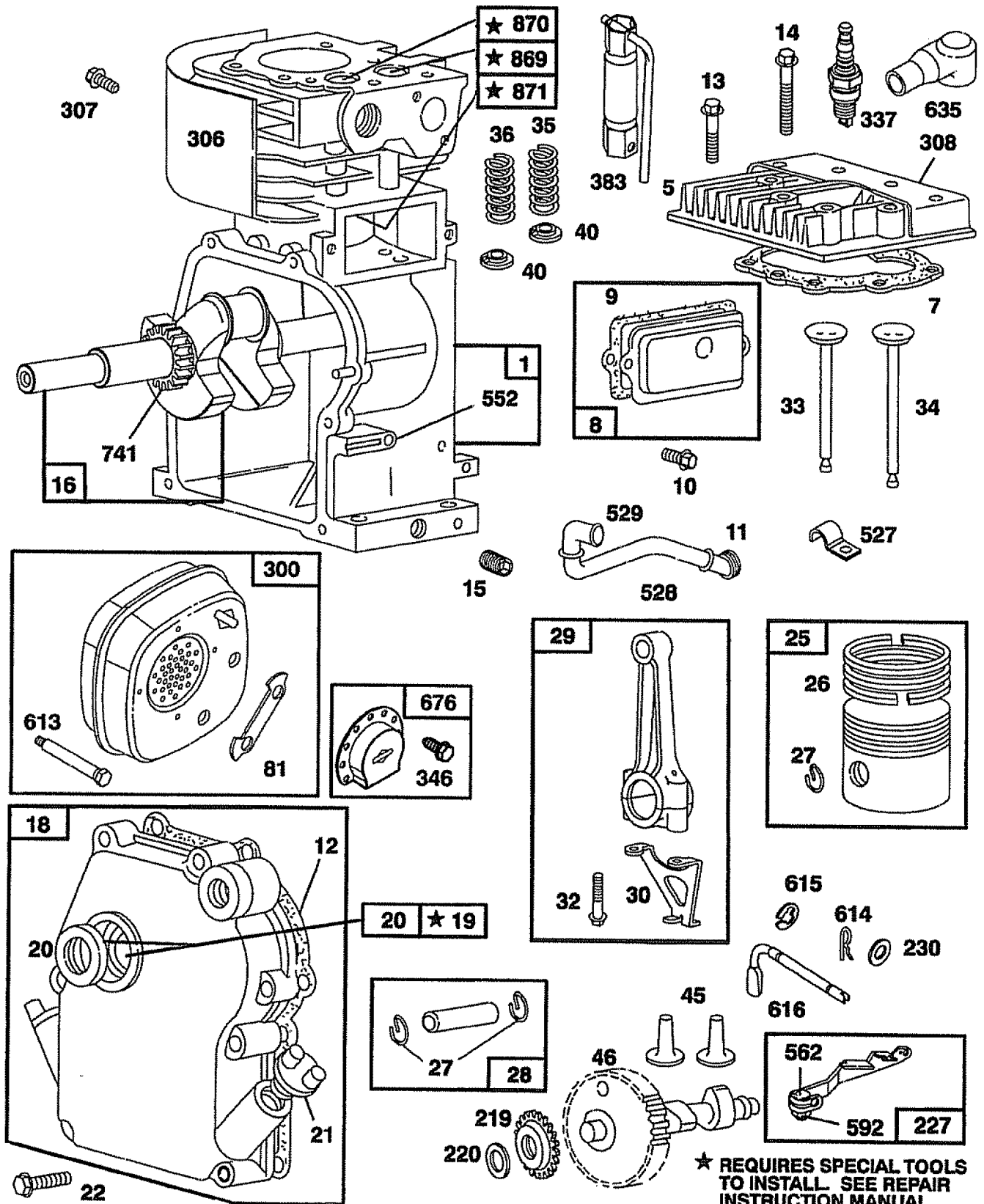

REPAIR PARTS

5 HP 17" TILLER - - MODEL NUMBER 917.298560

ENGINE, BRIGGS & STRATTON - - MODEL NUMBER 135202, TYPE NO. 0145-01

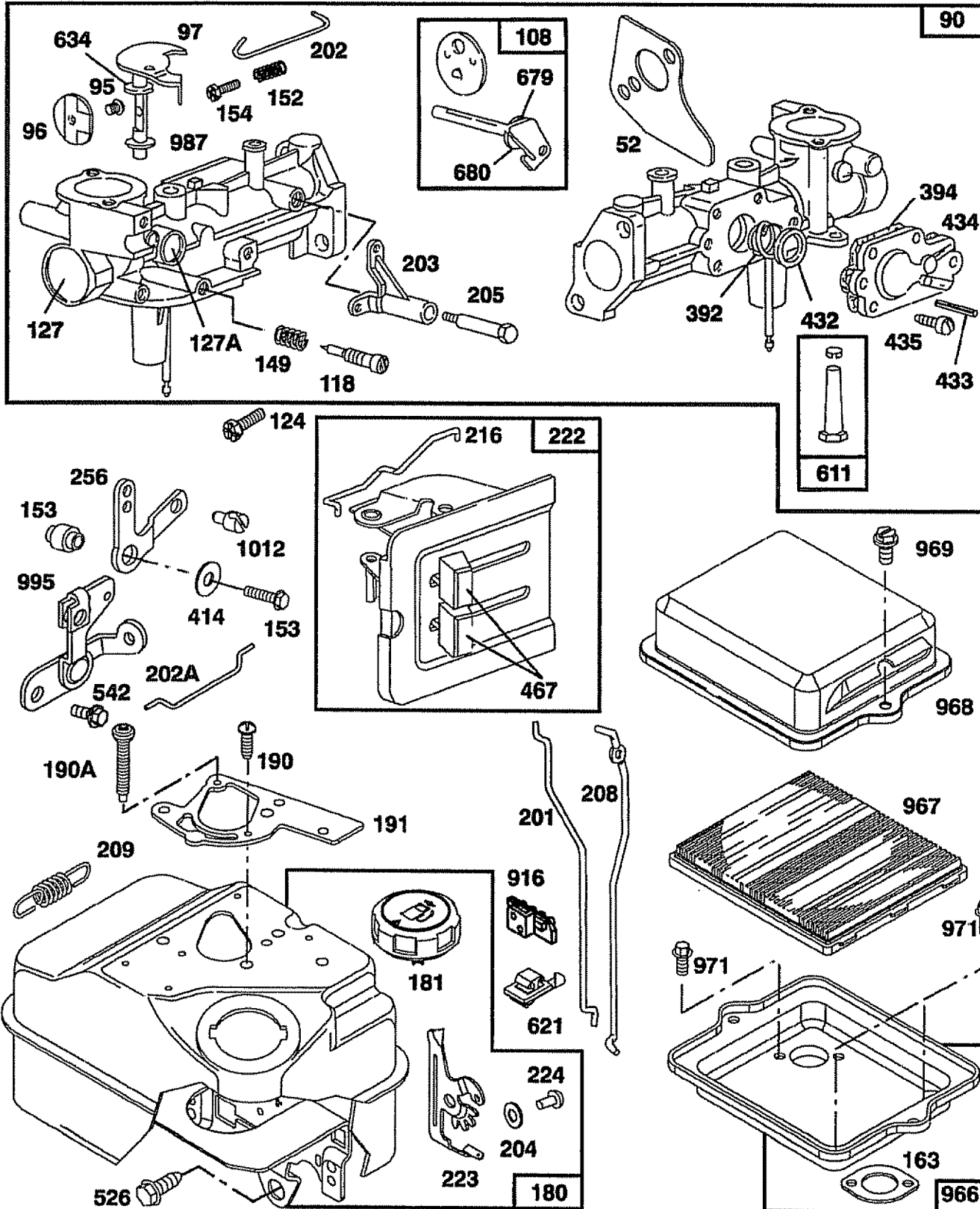

REPAIR PARTS

5 HP 17" TILLER - - MODEL NUMBER 917.298560

ENGINE, BRIGGS & STRATTON - - MODEL NUMBER 135202, TYPE NO. 0145-01

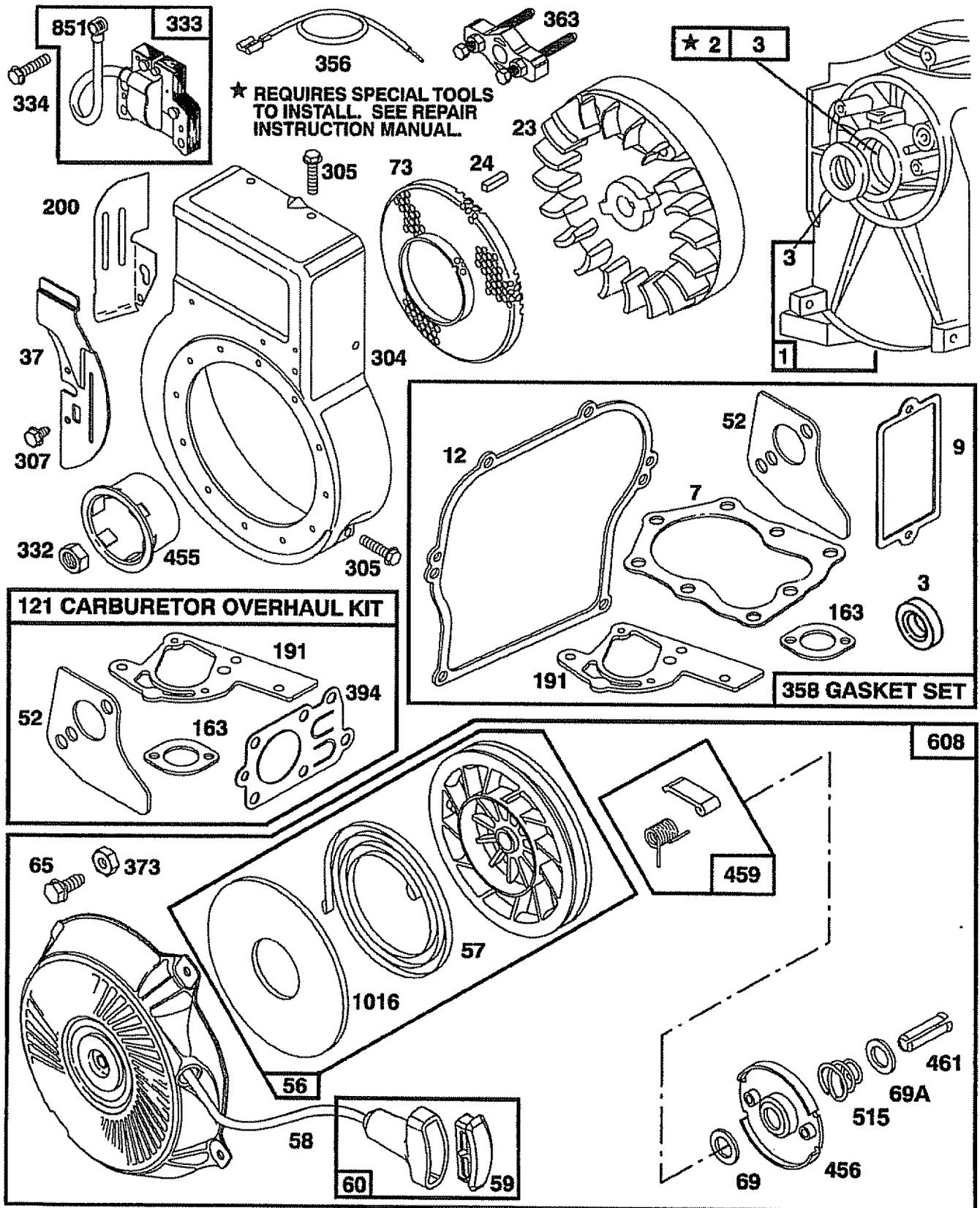

REPAIR PARTS

5 HP 17" TILLER - - MODEL NUMBER 917.298560

ENGINE, BRIGGS & STRATTON - - MODEL NUMBER 135202, TYPE NO. 0145-01

KEY PART NO. NO.	DESCRIPTION	KEY PART NO. NO.	DESCRIPTION
1 395990	Cylinder Assembly	37 222443	Guard, Flywheel
2 297565	Bushing, Cylinder	40 93312	Retainer, Intake Valve and Exhaust Spring
3 299819	* Seal, Oil	45 260642	Tappet, Valve
5 214040	Head, Cylinder	46 212733	Gear, Cam
7 272157	* Gasket, Cylinder Head	52 271936	*** Gasket, Carburetor Mounting (2)
8 495774	Breather Assembly	55 494846	Housing, Rewind Starter
9 27549	* Gasket, Valve Cover	56 493824	Pulley, Rewind Starter
10 94621	Screw, Breather Mounting	57 262594	Spring, Rewind Starter
11 66578	Grommet, Breather Tube	58 280406	Rope, Rewind Starter (Cut to Required Length)
12 270080	* Gasket, Crankcase, Standard .015"	59 396892	Insert, Starter Handle
270125	* Gasket, Crankcase .005" Thick	60 393152	Handle, Rewind Starter
270126	* Gasket, Crankcase .009" Thick	65 94686	Screw, Housing Mounting
13 94221	Screw, Cylinder Head 2-3/32"	69 280973	Washer
14 94679	Screw, Cylinder Head 2-15/32"	69A 224322	Washer
15 93448	Plug, Pipe, Hex Socket	73 224632	Screen, Rotating
94387	Plug, Oil Drain	81 222263	Lock, Screw
16 492088	Crankshaft	90 495426	Carburetor Assembly
230978	Gear Pin, Crankshaft	95 93499	Screw, Throttle Valve to Shaft
18 297602	Cover Assembly, Crankcase	96 223793	Throttle, Carburetor
19 495660	Bushing, Crankcase Cover	97 490048	Shaft and Lever, Throttle
20 294606	* Seal, Oil	108 491177	Valve and Shaft Group, Choke
21 66768	Plug, Oil Filler	118 231533	Valve, Needle
22 94682	Screw, Cover Mounting	121 495606	Carburetor Overhaul Kit
94666	Stud, Crankcase Cover	124 94616	Screw, Hex Head
23 297229	Flywheel, Magneto	127 220352	Plug, Welch
24 222698	Key, Flywheel	127A 223789	Plug, Welch
25 298904	Piston Assembly, Standard Size	149 26336	Spring, Needle Valve
298905	Piston Assembly .010" Oversize	152 260575	Spring, Throttle Adjustment
298906	Piston Assembly .020" Oversize	153 490589	Screw and Collar
298907	Piston Assembly .030" Oversize	154 93527	Screw, Machine, Round Head
26 298982	Ring Set, Piston, Standard Size	163 271935	*** Gasket, Air Cleaner Mounting
299742	Ring Set, Piston, Standard, Chrome	180 495301	Tank Assembly, Fuel
298983	Ring Set, Piston .010" Oversize	181 494559	Cap, Fuel Tank
298984	Ring Set, Piston .020" Oversize	190 94712	Screw, Fuel Tank
298985	Ring Set, Piston .030" Oversize	190A 94677	Screw, Fuel Tank Mounting 1-3/4"
27 26026	Lock, Piston Pin	191 272489	*** Gasket, Fuel Tank to Carburetor
28 298909	Pin Assembly, Piston, Standard	200 223886	Guide, Air
298908	Pin Assembly, Piston .005" Over	201 262280	Link, Governor
29 299430	Rod Assembly, Connecting		
390459	Rod Assembly, Connecting .020" Undersize Crankpin Bore		
30 221890	Dipper, Connecting Rod		
32 94745	Screw, Connecting Rod		
33 211119	Valve, Exhaust		
34 261044	Valve, Intake		
35 260552	Spring, Intake Valve		
36 26478	Spring, Exhaust Valve		

* Included in Gasket Set (495603)
 ** Included in Carburetor Overhaul Kit (495606)
 *** Included in both Gasket Set (495603), and Carburetor Overhaul Kit (495606)

NOTE: All component dimensions given in U.S. inches
 1 inch = 25.4 mm

REPAIR PARTS

5 HP 17" TILLER - - MODEL NUMBER 917.298560

ENGINE, BRIGGS & STRATTON - - MODEL NUMBER 135202, TYPE NO. 0145-01

KEY PART NO. NO.	DESCRIPTION	KEY PART NO. NO.	DESCRIPTION
202 262270	Link, Throttle	515 262625	Spring
202A 262470	Link, Control	526 94659	Screw, Sems, Tank Bracket Mount.
203 280720	Bell Crank	527 223786	Clamp, Breather Tube
204 222962	Bushing, Governor Lever, Flat	528 231550	Tube, Breather
205 231520	Screw, Shoulder	529 67838	Grommet, Breather Tube
208 262279	Rod, Speed Control	542 93572	Screw
209 262282	Spring, Governor	552 231079	Bushing, Governor Crank
216 262359	Link, Choke	562 92613	Bolt, Governor Lever
219 494845	Gear, Governor	592 231082	Nut, Hex
220 221551	Washer, Thrust	608 495766	Starter Assembly, Rewind
222 490649	Panel, Control	611 391813	Fuel Pipe and Clip Assembly
223 223455	Lever, Governor Control	613 93935	Screw, Hex Head, Shoulder
224 93491	Rivet, Governor Control Lever Mounting	614 93306	Pin, Cotter
227 490374	Lever Assembly, Governor	615 93307	Retainer, E-Ring
230 222450	Washer, Governor Lever	616 231077	Crank, Governor
256 223813	Crank, Bell	621 396847	Switch, Stop
300 393615	Muffler, Exhaust	634 271853	Washer, Throttle Shaft, Foam
304 495759	Housing, Blower	635 66538	Elbow, Spark Plug
305 94619	Screw, Blower Housing Mounting	676 393757	Deflector, Exhaust, Side Outlet
306 221511	Shield, Cylinder	679 270382	Washer, Foam
307 94680	Screw, Cylinder Shield	680 221839	Washer, Brass
308 224738	Cover, Cylinder Head	741 261696	Gear, Timing
332 92284	Nut, Flywheel	851 221798	Cable Terminal, Ignition
333 397358	Armature Group	869 211787	Seat, Intake Valve, Standard
334 93414	Screw, Armature Mounting	870 211172	Seat, Exhaust Valve, Standard
337 802592	Plug, Spark	871 262001	Guide, Exhaust Valve
346 93705	Screw, Sems	63709	Guide, Intake Valve
356 398808	Wire, Ground	916 280321	Rack, Gear Control
358 495603	Gasket Set	966 492797	Base, Air Cleaner
363 19069	Flywheel Puller	967 491588	Filter, Air Cleaner
373 92987	Nut, Hex	968 495357	Cover, Air Cleaner
383 89838	Wrench, Spark Plug	969 490073	Screw, Air Cleaner
392 262328	Spring, Fuel Pump Diaphragm	971 94018	Screw, Hex Head
394 272538	** Diaphragm	987 398970	Seal, Throttle Shaft
414 220982	Washer	995 491577	Lever, Bracket Assembly
432 221377	Cap, Spring	1012 490507	Retainer, Link
433 93265	Pin, Diaphragm Cover	1016 224278	Spacer
434 214021	Cover, Diaphragm		
435 93141	Screw, Diaphragm Cover		
455 224250	Cup, Starter		
456 224321	Retainer		
459 492833	Pawl, Starter		
461 262626	Pin, Spring		
467 280715	Knob, Control		

- * Included in Gasket Set (495603)
- ** Included in Carburetor Overhaul Kit (495606)
- *** Included in both Gasket Set (495603), and Carburetor Overhaul Kit (495606)

NOTE: All component dimensions given in U.S. inches
1 inch = 25.4 mm

SERVICE NOTES

SERVICE NOTES

SERVICE NOTES

SEARS
OWNER'S
MANUAL

MODEL NO.
917.298560

HOW TO ORDER
REPAIR PARTS

CRAFTSMAN[®]
5.0 HP
17 INCH TINE WIDTH
REAR TINE TILLER WITH
COUNTER ROTATING TINES

Each tiller has its own model number. Each engine has its own model number.

The model number for your tiller will be found on a plate attached to the top of the transmission.

The model number for your engine will be found on the blower housing of the engine adjacent to the spark plug.

All parts listed herein may be ordered from any Sears, Roebuck, and Co. Service Center and most Retail Stores.

WHEN ORDERING REPAIR PARTS, ALWAYS GIVE THE FOLLOWING INFORMATION:

- **PRODUCT - REAR TINE TILLER**
- **MODEL NUMBER - 917.298560**
- **ENGINE MODEL NUMBER - 135202, TYPE NUMBER 0145-01**
- **PART NUMBER**
- **PART DESCRIPTION**

Your Sears merchandise has added value when you consider Sears has service units nationwide staffed with Sears trained technicians... professional technicians specifically trained to insure that we meet our pledge to you, we service what we sell.

Sears, Roebuck and Co., Hoffman Estates, IL 60179 U.S.A.
