



Owner's Manual



10-in. Buffer / Polisher

Model No.
172.107230

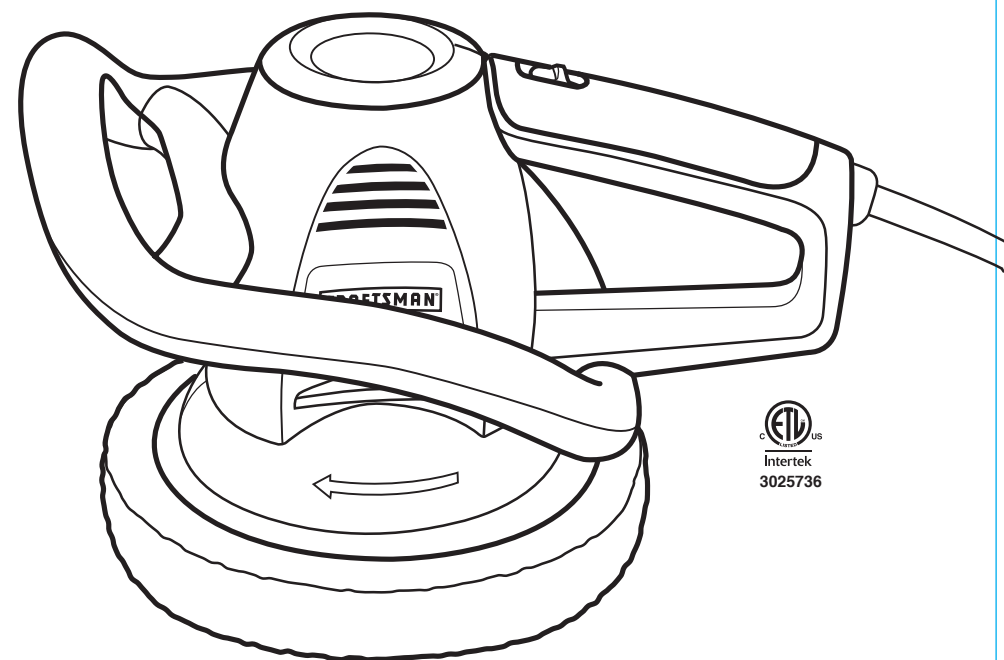

CAUTION: Read, understand and follow all Safety Rules and Operating Instructions in this manual before using this product.

Sears Brands Management Corporation,
Hoffman Estates, IL 60179 U.S.A.
www.sears.com

Double Insulated

- WARRANTY
- SAFETY
- UNPACKING
- DESCRIPTION
- OPERATION
- MAINTENANCE
- ACCESSORIES

TABLE OF CONTENTS

Warranty.....	Page 2
Safety Symbols.....	Page 3
Safety Instructions.....	Pages 4-9
Unpacking.....	Page 10
Description.....	Page 11
Operation.....	Pages 12-16
Maintenance.....	Page 16
Accessories.....	Page 17

CRAFTSMAN® ONE YEAR LIMITED WARRANTY

FOR ONE YEAR from date of purchase, this product is warranted against any defects in material or workmanship. With proof of purchase, defective product will be replaced free of charge.

For warranty coverage details to obtain free replacement, visit the web site: www.craftsman.com

This warranty does not cover the bonnets and applicator pad, which are expendable parts that can wear out from normal use within the warranty period.

This warranty is void if this product is ever used while providing commercial services or if rented to another person.

This warranty gives you specific legal rights, and you may also have other rights which vary from state to state.

Sears Brands Management Corporation, Hoffman Estates, IL 60179

SAVE THESE INSTRUCTIONS! READ ALL INSTRUCTIONS!

⚠ WARNING: Some dust created by using power tools contains chemicals known to the State of California to cause cancer and birth defects or other reproductive harm.

SAFETY SYMBOLS

The purpose of safety symbols is to attract your attention to possible dangers. The safety symbols and the explanations with them deserve your careful attention and understanding. The symbol warnings do not, by themselves, eliminate any danger. The instructions and warnings they give are no substitutes for proper accident prevention measures.

⚠ WARNING: Be sure to read and understand all safety instructions in this manual, including all safety alert symbols such as “**DANGER**,” “**WARNING**,” and “**CAUTION**” before using this buffer/polisher. Failure to follow all instructions listed in this manual may result in electric shock, fire and/or serious personal injury.

SYMBOL SIGNAL MEANING

⚠ SAFETY ALERT SYMBOL: Indicates **DANGER, WARNING, OR CAUTION**. May be used in conjunction with other symbols or pictographs.

⚠ DANGER: Indicates a hazardous situation which, if not avoided, will result in death or serious injury. This signal word is to be limited to the most extreme situations. Always follow the safety precautions to reduce the risk of fire, electric shock, and personal injury.

⚠ WARNING: Indicates a hazardous situation which, if not avoided, could result in death or serious injury. Always follow the safety precautions to reduce the risk of fire, electric shock, and personal injury.

⚠ CAUTION: Indicates a hazardous situation which, if not avoided, could result in minor or moderate injury.

Damage Prevention and Information Messages

These inform the user of important information and/or instructions that could lead to equipment or other property damage if they are not followed. Each message is preceded by the word “NOTE,” as in the example below:

NOTE: Equipment and/or property damage may result if these instructions are not followed.

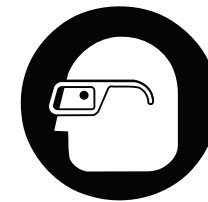

⚠ WARNING: To ensure safety and reliability, all repairs should be performed by a qualified service technician.

⚠ WARNING: The operation of any power tools can result in foreign objects being thrown into your eyes, which can result in severe eye damage. Before beginning power tool operation, always wear safety goggles or

safety glasses with side shield and a full face shield when needed. We recommend a Wide Vision Safety Mask for use over eyeglasses or standard safety glasses with side shields. Always use eye protection that is marked to comply with ANSI Z87.1 shields.

SAFETY INSTRUCTIONS

⚠ WARNING: Read all safety warnings and instructions.
Failure to follow the warnings and instructions may result in electric shock, fire and/or serious injury.

Save all warnings and instructions for future reference. The term power tool in the warnings refers to your electric (corded) power tool or battery-operated (cordless) power tool.

WORK AREA SAFETY

1. **Keep your work area clean and well lit.** Cluttered and dark areas invite accidents.
2. **DO NOT operate power tools in explosive atmospheres, such as in the presence of flammable liquids, gases, or dust.** Power tools create sparks which may ignite the dust or fumes.
3. **Keep children and bystanders away while operating a power tool.** Distractions can cause you to lose control.
4. **MAKE SURE the work area has ample lighting** so you can see the work and that there are no obstructions that will interfere with safe operation **BEFORE** using your buffer / polisher.

PERSONAL SAFETY

1. **Stay alert, watch what you are doing and use common sense when operating a power tool. Do not use a power tool while you are tired or under the influence of drugs, alcohol or medication.** A moment of inattention while operating power tools may result in serious personal injury.
2. **Use personal protective equipment. Always wear eye protection.** Protective equipment such as dust mask, non-skid safety shoes, hard hat, or hearing protection used for appropriate conditions will reduce personal injuries.
3. **Prevent unintentional starting. Ensure the switch is in the off-position before connecting to power source and/or battery pack, picking up or carrying the tool.** Carrying power tools with your finger on the switch or energizing power tools that have the switch on invites accidents.
4. **Remove any adjusting key or wrench before turning the power tool on.** A wrench or a key left attached to a rotating part of the power tool may result in personal injury.
5. **Do not overreach. Keep proper footing and balance at all times.** This enables better control of the power tool in unexpected situations.
6. **Dress properly. Do not wear loose clothing or jewelry. Keep your hair, clothing and gloves away from moving parts.** Loose clothes, jewelry or long hair can be caught in moving parts.
7. **If devices are provided for the connection of dust extraction and collection facilities, ensure these are connected and properly used.** Use of dust collection can reduce dust-related hazards.

SAFETY INSTRUCTIONS cont.

TOOL USE AND CARE SAFETY

⚠ WARNING: BE SURE to read and understand all instructions before operating this tool. Failure to follow all instructions listed below may result in electric shock, fire and/or serious personal injury.

1. **Do not force the power tool. Use the correct power tool for your application.** The correct power tool will do the job better and safer at the rate for which it was designed.
2. **Do not use the power tool if the switch does not turn it on and off.** Any power tool that cannot be controlled with the switch is dangerous and must be repaired.
3. **Disconnect the plug from the power source and/or the battery pack from the power tool before making any adjustments, changing accessories, or storing power tools.** Such preventive safety measures reduce the risk of starting the power tool accidentally.
4. **Store idle power tools out of the reach of children and do not allow persons unfamiliar with the power tool or these instructions to operate the power tool.** Power tools are dangerous in the hands of untrained users.
5. **Maintain power tools. Check for misalignment or binding of moving parts, breakage of parts and any other condition that may affect the power tools operation. If damaged, have the power tool repaired before use.** Many accidents are caused by poorly maintained power tools.
6. **Keep cutting tools sharp and clean.** Properly maintained cutting tools with sharp cutting edges are less likely to bind and are easier to control.
7. **Use the power tool, accessories and tool bits etc., in accordance with these instructions and in the manner intended for the particular type of power tool, taking into account the working conditions and the work to be performed.** Use of the power tool for operations different from those intended could result in a hazardous situation.
8. **Use clamps or another practical way to secure and support the workpiece to a stable platform.**
9. **Holding the work by hand or against your body leaves it unstable and may lead to loss of control.**

ELECTRICAL SAFETY

1. **Double insulated tools are equipped with a polarized plug (one blade is wider than the other). This plug will fit in a polarized outlet only one way.** If the plug does not fit fully in the outlet, reverse the plug. If it still does not fit, contact a **qualified electrician** to install a polarized outlet. Do not change the plug in any way.
2. **Power tool plugs must match the outlet. Never modify the plug in any way. Do not use any adapter plugs with grounded power tools.** Unmodified plugs and matching outlets will reduce risk of electric shock.
3. **BEFORE plugging in the tool, BE SURE that the outlet voltage supplied is within the voltage marked on the tool's data plate. DO NOT use "AC only" rated tools with a DC power supply.**

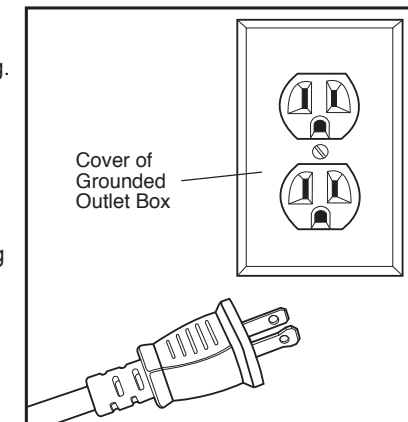

SAFETY INSTRUCTIONS cont.

ELECTRICAL SAFETY cont.

4. **AVOID body contact with grounded surfaces**, such as pipes, radiators, ranges and refrigerators. There is an increased risk of electric shock if your body is grounded.
5. **DO NOT expose power tools to rain or wet conditions or use power tools in wet or damp locations.** Water entering a power tool will increase the risk of electric shock.
6. **INSPECT tool cords for damage.** Have damaged tool cords repaired at a **Sears Service Center**. **BE SURE** to stay constantly aware of the cord location and keep it well away from the moving blade.
7. **DO NOT abuse the cord. NEVER use the cord to carry the tool by or to pull the plug from the outlet.** Keep cord away from heat, oil, sharp edges or moving parts. Replace damaged cords immediately. Damaged cords increase the risk of electric shock.
8. **When operating a power tool outdoors, use an extension cord suitable for outdoor use marked “W-A” or “W”.** Use of a cord suitable for outdoor use reduces the risk of electric shock.
9. **If operating a power tool in a damp location is unavoidable, use a Ground Fault Circuit Interrupter (GFCI) protected supply.** Use of a GFCI reduces the risk of electric shock.

EXTENSION CORDS

USE PROPER EXTENSION CORD. Make sure your extension cord is in good condition. When using an extension cord, be sure to use one heavy enough to carry the current your product will draw. An undersized cord will cause a drop in line voltage resulting in loss of power and overheating. Table 1 shows the correct size to use depending on cord length and nameplate ampere rating. If in doubt, use the next heavier gage. The smaller the gage number, the heavier the cord.

Table 1: Minimum gage for cord

Rating		Volts	Total cord length (in feet)			
			120V	25	50	100
More Than	Not More Than	AWG				
0	6		18	16	16	14
6	10		18	16	14	12
10	12		16	16	14	12
12	16		14	12	Not recommended	

⚠ CAUTION: Keep the extension cord clear of the working area. Position the cord so that it will not get caught on lumber, tools, parts of the vehicle or other obstructions while you are working with a power tool.

⚠ WARNING: Check extension cords before each use. If damaged replace immediately. Never use tool with a damaged cord since touching the damaged area could cause electrical shock, resulting in serious injury.

SAFETY INSTRUCTIONS cont.

SAFETY SYMBOLS FOR YOUR TOOL

The label on your tool may include the following symbols.

V.....	Volts
A.....	Amps
Hz.....	Hertz
W.....	Watts
min.....	Minutes
~.....	Alternating current
—.....	Direct current
n _o	No-load speed
□.....	Class II construction, Double Insulated
RPM.....	Revolutions per minute
SPM.....	Strokes per minute
OPM.....	Orbits per minute
⚠.....	Indicates danger, warning or caution. It means attention! Your safety is involved.

SERVICE SAFETY

1. **If any part of this tool is missing or should break, bend, or fail in any way; or should any electrical component fail to perform properly: SHUT OFF** the power switch and remove the tool's plug from the power source and have the missing, damaged or failed parts replaced **BEFORE** resuming operation.
2. **Have your power tool serviced by a qualified repair person using only identical replacement parts.** This will ensure that the safety of the power tool is maintained.
3. **If the replacement of the supply cord is necessary, this has to be done by the manufacturer or his agent in order to avoid a safety hazard.**

SAFETY RULES FOR BUFFER / POLISHERS

⚠ WARNING: USE OF ACCESSORIES THAT ARE NOT RECOMMENDED FOR USE WITH THIS TOOL MAY CREATE A HAZARDOUS CONDITION.

1. Read, understand and follow all safety rules and user instructions in this manual and all directions and warnings on polishes and waxes **BEFORE** using this buffer / polisher.
2. Vehicle should be clean and dry before using your buffer polisher. Remove all road tar, excess grease spots and bug stains.
3. **ALWAYS** make sure the vehicle's surface is cool before washing and using the buffer / polisher.
4. When changing accessories, **BE SURE** that the switch is in the **OFF** position and the cord is unplugged.
5. **DO NOT apply wax directly on car.**

SAFETY INSTRUCTIONS cont.

SAFETY RULES FOR BUFFER / POLISHERS cont.

6. To avoid splashing wax, **ALWAYS** start and stop the buffer / polisher on or against the surface to be polished.
7. After plugging in extension cord, loop extension cord over tool's stub length plug. Then wrap hook and loop strip around extension cord to secure it in place.
8. Place extension cord over your shoulder to keep it safely out of your way.
9. **DO NOT** apply excessive pressure against the work surface with this tool. The random orbital motion feature on this tool will perform better when less pressure is applied. Applying excessive pressure will slow the random orbital motion and reduce the effectiveness of the tool.
10. To prolong the life of the pad on the buffer / polisher, **ALWAYS** store the buffer / polisher with the pad face up.
11. **DO NOT USE ABRASIVE COMPOUNDS WITH THIS TOOL.**
12. **DO NOT** immerse any part of the buffer / polisher in liquid.

 **WARNING: Some dust created by using power tools contains chemicals known to the State of California to cause cancer and birth defects or other reproductive harm. Some examples of these chemicals are:**

- Lead from lead-based paints.
- Crystalline silica from bricks and cement and other masonry products.
- Arsenic and chromium, from chemically treated lumber.

Your risk from these exposures varies, depending upon how often you do this type of work. To reduce your exposure to these chemicals:

- Work in a well-ventilated area.
- Work with approved safety equipment, such as those dust masks that are specially designed to filter out microscopic particles.

Avoid prolonged contact with dust from power sanding, sawing, grinding, drilling and other construction activities. Wear protective clothing and wash exposed areas with soap and water. Allowing dust to get into your mouth, eyes, or lay on the skin may promote absorption of harmful chemicals.

 **WARNING: Use of this tool can generate and/or disburse dust, which may cause serious and permanent respiratory or other injury. Always use NIOSH/OSHA approved respiratory protection appropriate for the dust exposure. Direct particles away from face and body.**

SAFETY INSTRUCTIONS cont.

ADDITIONAL RULES FOR SAFE OPERATION

 **WARNING: BE SURE to read and understand all instructions. Failure to follow all instructions listed below may result in electric shock, fire and/or serious personal injury.**

1. **Know your power tool. Read operator's manual carefully.** Learn the applications and limitations, as well as the specific potential hazards related to this tool. Following this rule will reduce the risk of electric shock, fire or serious injury.
2. **ALWAYS wear eye protection when using this tool.**
3. **PROTECT your lungs.** Wear a face mask or dust mask if the operation is dusty.
4. **INSPECT the tool cords periodically and if damaged have them repaired at your nearest Sears Service Center. ALWAYS BE AWARE of the cord location when operating your tool.**
5. **ALWAYS check the tool for damaged parts.** Before further use of the tool, a guard or other part that is damaged should be carefully checked to determine if it will operate properly and perform its intended function. Check for misalignment or binding of moving parts, breakage of parts, and any other condition that may affect the tool's operation. A guard or other part that is damaged should be properly repaired or replaced at a Sears Service center.
6. Inspect the sponge pad before use. Do not use chipped, cracked or otherwise defective products.
7. Ensure that the bonnets are fitted in accordance with the manufacturer's instructions.
8. Ensure that the bonnet is correctly mounted and tightened before use and run the tool at no-load for 30 seconds in a safe position. Stop immediately if there is considerable vibration or if other defects are detected. If this condition occurs, check the machine to determine the cause.
9. For cleaning, personal protective equipment such as gloves and apron should be worn.
10. The wheel continues to rotate after the tool is switched off. Only withdraw the sponge pad when the pad has stopped moving.
11. Do not use the polisher as a fixed tool.

UNPACKING

⚠ WARNING: Your tool should **NEVER** be connected to the power source when you are assembling parts, making adjustments, installing or removing bonnets, cleaning or when it is not in use. Disconnecting the tool will prevent accidental starting, which could cause serious personal injury.

1. Remove the buffer / polisher from the bucket and inspect it carefully to make sure that no breakage or damage has occurred during shipping.
2. Do not discard any of the packing materials until all parts are accounted for.
3. Seven bonnets are included: three wax applicator bonnets for applying waxes, three reusable terry cloth bonnets for removing waxes and polishing, one reusable bonnet for polishing, and one hand applicator pad.
4. If any of the parts are damaged or missing (refer to PARTS LIST below), return the buffer / polisher to your nearest Sears store or Craftsman outlet to have the tool replaced.

⚠ WARNING: If any parts are missing, **DO NOT** operate this buffer / polisher until the missing parts are replaced. Failure to do so could result in possible serious personal injury.

PARTS LIST (Fig. 1)

5-gallon Bucket for storage or use

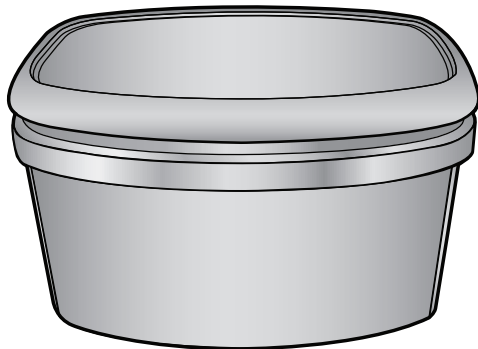

Buffer / Polisher

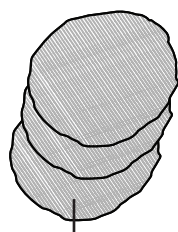
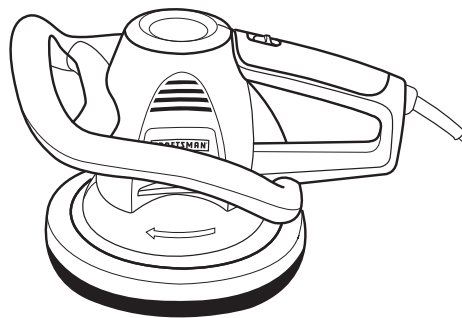

Three Wax Applicator Bonnets

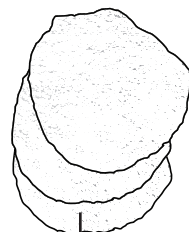

Three Reusable Terry Cloth Bonnets

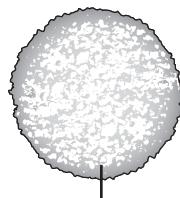

One Reusable Polishing Bonnet



One Hand Applicator Pad

Operator's Manual

DESCRIPTION

KNOW YOUR BUFFER / POLISHER

NOTE: Before attempting to use your buffer / polisher, familiarize yourself with all of the operating features and safety requirements.

Your Craftsman buffer / polisher has a precision-built electric motor and it should be connected to a 120-volt, 60-Hz AC **ONLY** power supply (normal household current). **DO NOT** operate on direct current (DC). The large voltage drop will cause a loss of power and the motor will overheat. If the tool does not operate when plugged into correct 120-volt, 60-Hz AC **ONLY** outlet, check the power supply. This buffer / polisher has a stub length, 2-wire power cord (no adapter needed).

This Craftsman Buffer / Polisher has the following features:

1. **Powerful 1.1 Amp Motor with 2800 Orbits per Minute** provides the power needed for quality waxing, buffing and polishing.
2. Precision tuned **Counterweight system** reduces vibration for smooth, comfortable operation with less operator fatigue
3. Precision tuned **Counterweight System** matched with **Orbital Motion** provides a "swirl-free" shine.
4. Ergonomically designed **Perimeter Handle System** provides maximum balance, control and gripping comfort on any horizontal or vertical surface.
5. **Hook and Loop Strip** helps keep extension cord securely plugged into buffer / polisher.
6. **On / Off Slide Switch** conveniently located for ease in control.
7. **10-in. diameter Foam Pad** follows surface contours for efficient buffing / polishing. Chemical resistant for long life.
8. **Three Wax Applicator Bonnets** for applying waxes.
9. **One Hand Applicator Pad** for applying waxes to hard to get at places.
10. **Three Reusable Terry Cloth Bonnets** for removing wax and polishing.
11. **One Reusable Polishing Bonnet** for final polishing to a "show room shine".
12. **Non-marring Flat Top** of buffer / polisher provides a stable base when applying wax to bonnets and changing bonnets.
13. **Permanently lubricated Ball Bearings** for smooth, efficient operation.
14. **Lightweight, High-impact Resistant Housing** reduces weight, helps protect tool from damage.

DESCRIPTION cont.

KNOW YOUR BUFFER / POLISHER cont.

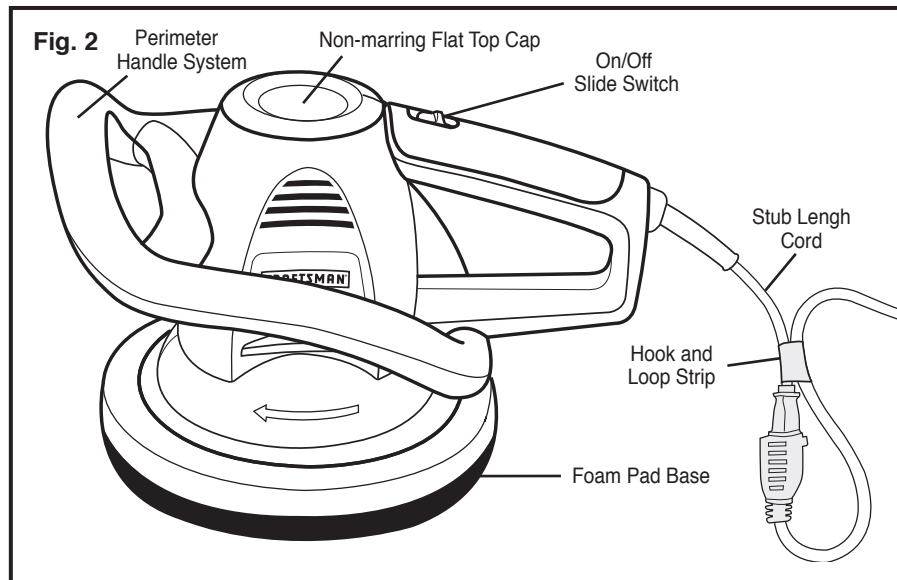

PRODUCT SPECIFICATIONS

Pad Diameter	10-in.
Motor OPM	2800
Rating	120 volts, 60 Hz AC
Amps	1.1

OPERATION

Before attempting to use your tool, familiarize yourself with all of the operating features and safety requirements.

⚠ WARNING: IF ANY PARTS ARE MISSING, DO NOT OPERATE THIS BUFFER / POLISHER UNTIL THE MISSING PARTS ARE REPLACED. FAILURE TO DO SO COULD RESULT IN POSSIBLE SERIOUS PERSONAL INJURY.

⚠ CAUTION: ALWAYS wear eye protection while operating this power tool.

OPERATION cont.

BEFORE YOU BEGIN TO WAX, BUFF AND POLISH YOUR CAR:

1. Remove all road tar, excess grease spots and bug stains with a general-purpose cleaner.
2. Wash, clean and dry your vehicle. Your buffer polisher comes in a 5-gallon bucket, which can be used for washing the vehicle.
3. Make sure the work area is dry.

ATTACHING THE WAX APPLICATOR BONNET TO THE FOAM PAD (See Figure 3)

⚠ WARNING: When changing accessories, **BE SURE** that the switch is in the **OFF** position and the cord is unplugged.

1. Place wax applicator bonnet on foam pad as shown in Fig. 3.
2. **ALWAYS** make sure that the elastic strip on the bottom of the bonnet is **securely** tucked on the underside of the foam pad.

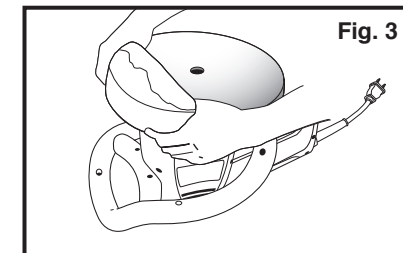

APPLYING WAX TO BONNET (See Figures 4 and 5)

IMPORTANT: DO NOT APPLY WAX DIRECTLY ON CAR!

Applying Paste Wax to Bonnet (See Figure 4)

1. Spread a heaping teaspoon of wax evenly over entire surface of applicator bonnet using a putty knife or any other flat object (See Fig. 4).

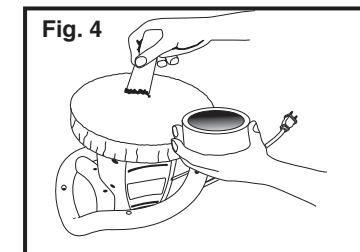

Applying Liquid Wax to Bonnet (See Figure 5)

1. Apply three swirls of wax over applicator bonnet (See Fig. 5).
2. This should be enough to cover 1/4 of car surface.
3. For the second and third and fourth applications, only use about one half as much as on first application. The bonnet will not absorb as much wax on these applications.

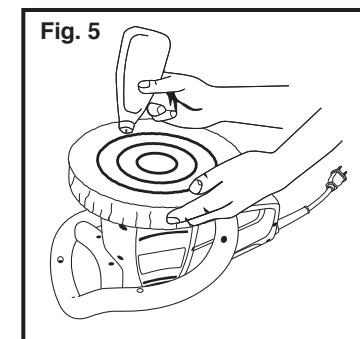

OPERATION cont.

RUNNING YOUR BUFFER / POLISHER AND WAXING VEHICLE

1. After plugging tool into extension cord, loop extension cord over tool's stub length plug. Then wrap hook and loop strip around extension cord to secure it in place.
2. To avoid splashing wax, **ALWAYS** start and stop the buffer / polisher against the surface to be polished.
3. Place the extension cord over your shoulder to keep it safely out of your way (see Fig. 6).
4. Place buffer / polisher against vehicle and turn buffer / polisher **ON** by sliding switch to On position.

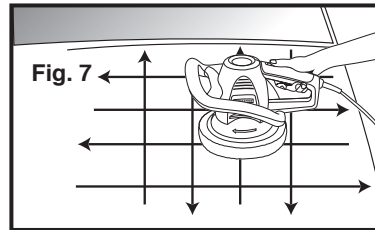
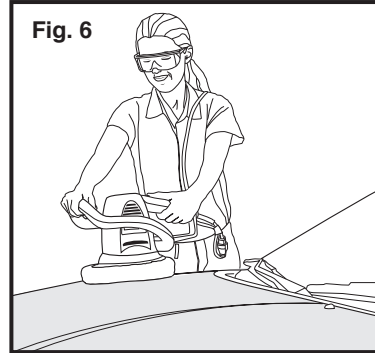

5. Apply wax in a straight line with either a side-to-side or back and forth motion. **ALWAYS** use broad, even strokes when applying wax (See Fig. 7).
6. Start applying wax to the flat surfaces (hood, trunk and roof) first. Wax one section at a time (see Fig. 8).
7. After flat surfaces are covered with wax, do the sides. The perimeter handle system allows easy polishing of horizontal and vertical surfaces. Hold tool with the cord hanging free (see Fig. 9).
8. Apply wax in a thin, even coat. Too much wax does not add any more protection and only makes the wax removal more difficult.
9. The random orbit motion of the buffer / polisher provides an application that cannot be duplicated, not even "by hand".

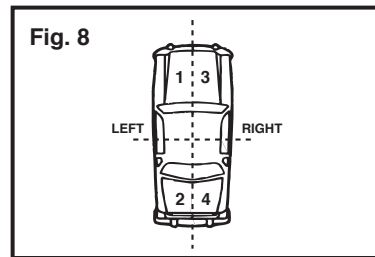

IMPORTANT: DO NOT apply excessive pressure against the work surface with this tool. The random orbital motion feature on this tool will perform better when less pressure is applied. Applying excessive pressure will slow the random orbital motion and reduce the effectiveness of the tool.

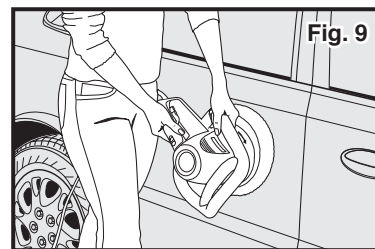

10. It is easiest to apply the wax to the entire surface before starting the removal phase; however, follow the specific recommendations of the wax or polish being used.
11. When you have finished applying wax with the applicator, bonnet, SHUT OFF the buffer / polisher before removing from the car's surface.

OPERATION cont.

RUNNING YOUR BUFFER / POLISHER AND WAXING VEHICLE cont.

12. You can use the hand applicator pad included with the buffer / polisher to hand wax all the hard-to-reach surfaces (under bumpers, around door handles, etc.), or remove the wax applicator bonnet and use it to hand polish all the hard-to-reach surfaces (see Fig. 10).
13. Properly dispose of wax applicator bonnet.

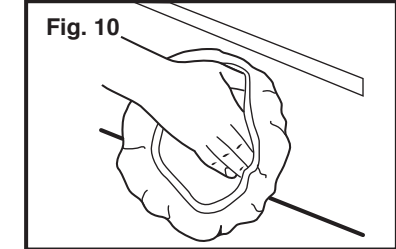

ATTACHING THE POLISHING BONNET TO THE FOAM PAD (Fig. 11)

⚠ WARNING: When changing accessories, **BE SURE** that the switch is in the **OFF** position and the cord is unplugged.

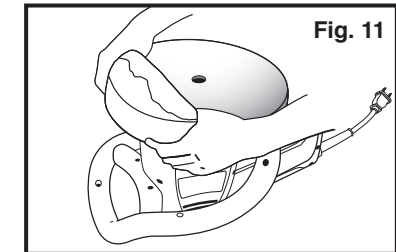

1. Place the terry bonnet on foam pad as shown in Fig. 11.
2. **ALWAYS** make sure that the elastic strip on the bottom of the bonnet is securely tucked on the underside of the foam pad.

BUFFING AND POLISHING - REMOVING THE WAX FROM THE SURFACE (See Fig. 12)

NOTE: Remove wax in the same order in which it was applied.

1. Wait until wax has dried to an even haze on vehicle.
2. Place extension cord over your shoulder.
3. Turn buffer / polisher ON.

IMPORTANT: DO NOT apply excessive pressure against the work surface with this tool. The random orbital motion feature on this tool will perform better when less pressure is applied. Applying excessive pressure will slow the random orbital motion and reduce the effectiveness of the tool.

NOTE: For best results, use long, sweeping strokes in a criss-cross pattern when removing wax.

4. Buff and polish the entire surface until all dried wax is removed. Remove the bonnet from time to time and shake out the dried wax residue. A bonnet with excess residue will cause streaking. You may need to replace the bonnet with a new one if you can't get it clean enough to avoid streaking.
5. Use a clean terry cloth bonnet for final buffing and polishing, or use the polishing bonnet for the ultimate "showroom" shine.

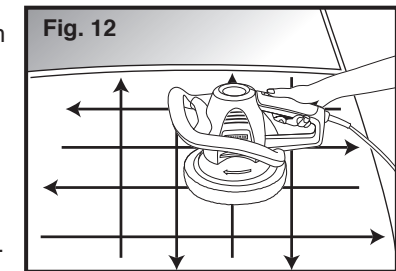

OPERATION cont.

CAR CARE TIPS

1. Wash and polish the car 3 to 4 times a year to help ensure paint protection.
2. Wash the car at least every 2 weeks with a car wash solution which will not harm the finish or strip the wax. **AVOID** washing with household detergents.
3. Wash with a clean sponge and dry with a terry cloth towel to help prevent dirt from scratching the paint. Start on the top and work down.
4. Remove bugs, bird droppings, tree sap and tar from the car's surface on a daily basis.
5. **ALWAYS** make sure that the car's surface is cool before washing.
6. Avoid parking near sprinklers, because water spots are difficult to remove.
7. **ALWAYS** keep glass cleaner chemicals away from painted surfaces. Spray the cleaner onto a towel, **NOT** directly on the windows.

MAINTENANCE

1. Terry cloth bonnets, polishing bonnet and hand applicator pad can all be machine washed in cold water, using a small amount of detergent. Machine dry at medium temperature. **HOWEVER**, we recommend hand washing and air drying for longer bonnet life.
2. Wax applicator bonnets should only be used once, then disposed of properly.
3. Remove the bonnet from the foam pad when the buffer / polisher is not in use, so the pad can dry out and retain its original shape.
4. To prolong the life of the foam pad, **ALWAYS** store the buffer / polisher with the pad face up.
5. **NEVER USE ABRASIVE COMPOUNDS WITH THIS TOOL.**
6. **DO NOT** apply too much wax to the bonnet. Applying too much wax causes the bonnet to become saturated and it will not last as long. **THIS MAKES POLISHING MORE DIFFICULT AND IT TAKES LONGER.**
7. If the bonnet is continually coming off the pad, you may be using too much wax.
8. **If buffing seems difficult, you have used too much wax.**
9. **ONLY USE** a mild soap solution and a damp sponge to clean the buffer / polisher.
10. **DO NOT immerse any part of the buffer / polisher in liquid.**

ACCESSORIES

 **WARNING:** The use of attachments or accessories that are not recommended for this tool might be dangerous and could result in serious injury.

Sears and other Craftsman® outlets offer a large selection of Craftsman buffer / polisher accessories designed for all your buffing and polishing applications.

Look for these Craftsman accessories. They are specially designed to make your 10-in. Buffer / Polisher more efficient to use.

Wax Applicator Bonnets for applying waxes and polishes.

Terry Cloth Bonnets use for removing wax and for buffing and polishing.

Polishing Bonnets for final buffing and polishing to a "showroom" shine.

Quality Waxes for the finest protection and appearance.

Visit your local Sears store or other Craftsman outlets or shop sears.com/craftsman for all of the accessories for your buffer / polisher.

PARTS LIST

10-in. Buffer / Polisher MODEL NUMBER 172.107230

The model number will be found on the nameplate of the buffer/polisher.
Always mention the model number in all correspondence regarding your tool.

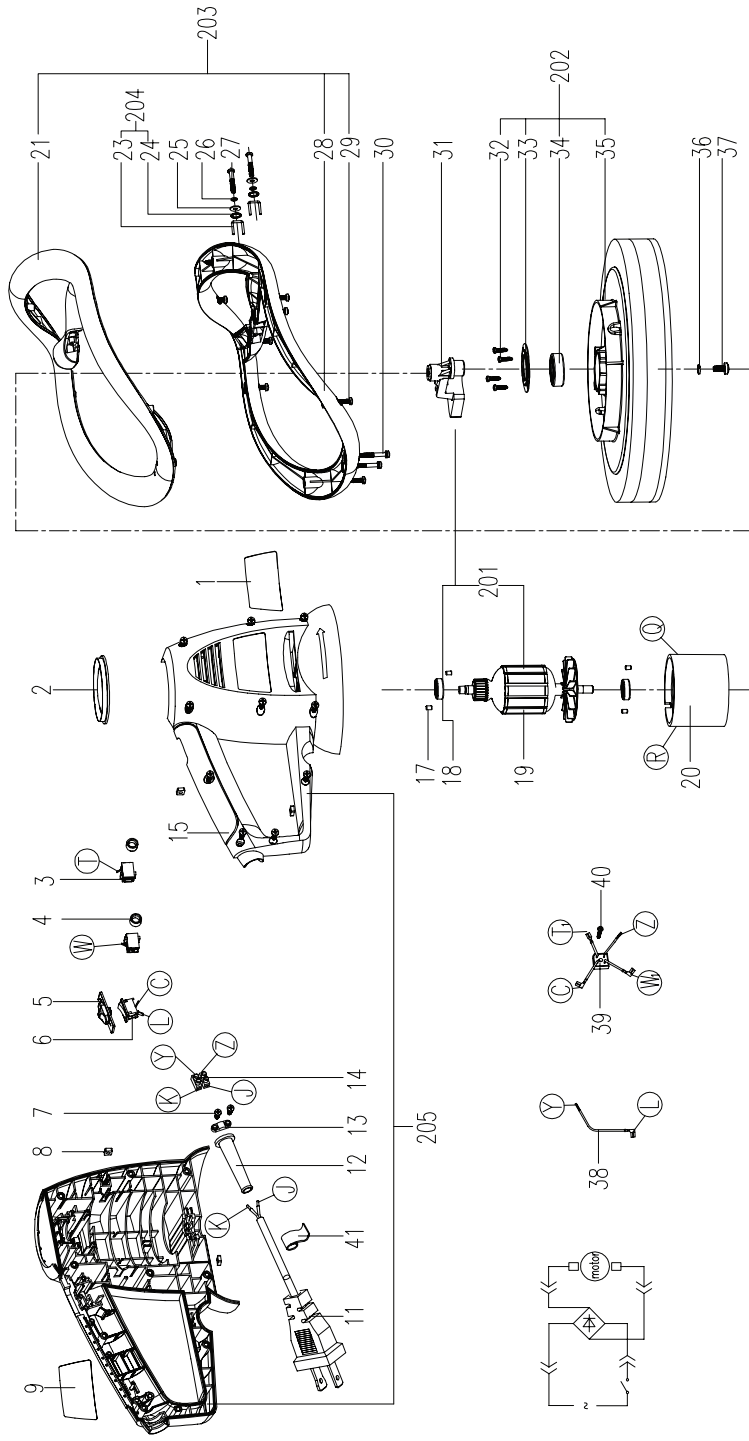

18

PARTS LIST

10-in. Buffer / Polisher MODEL NUMBER 172.107230

The model number will be found on the nameplate of the buffer/polisher.
Always mention the model number in all correspondence regarding your tool.

Item No.	Parts No.	Parts Description	Qty.
1	SA31.0.02.0-00	rated label	1
2	SA31.2.01-00	top cover	1
3	ST02.16.00-00	carbon brush	2
4	SA30.0.12-00	rubber cushion	2
5	SA30.0.03-00	switch pusher	1
6	SW02.44-00	switch	1
7	SW55.57.0-00	screw	2
8	SA30.0.06-00	square nut	4
9	SA31.0.01.0-00	brand	1
11	SW01.31.31-00	cable and plug	1
12	ST05.01.03-00	cable protector	1
13	ST08.01.07-00	cable clamp	1
14	SW09.01-00	terminal block	1
15	SW55.58.1-00	screw	10
17	ST05.04.52-00	rubber strip	4
18	SW50.14.0-00	ball bearing	2
19	STA51.13.02-00	rotor	1
20	STA50.13.00-00	stator	1
21	SA31.5.01-00	top handle	1
23	SA31.5.03-00	hoop	2
24	SA30.4.04-00	ring	2
25	SW60.77.1-00	washer	2
26	SW60.26.1-00	spring washer	2
27	SW56.23.1-00	screw	2
28	SA31.5.02-00	down handle	1
29	SW55.58.0-00	screw	8
30	SW57.58.1-00	screw	2
31	SA31.4.01-00	balance block	1
32	SW55.17.0-00	self-tapping screw	4
33	SA31.4.02-00	bearing baffle	1
34	SW50.09.0-00	ball bearing	1
35	SA31.4.10-00	base plate	1
36	SW60.04.0-00	washer	1
37	SW56.52.0-00	bolt	1
38	ST25.35.02.1-00	inner wire	1
39	SW11.50.11-00	connector	1
40	SW55.17.0-00	self-tapping screw	5
41	SQT030.3	loop and hoop	1
201	SA31.A.01-00	rotor set	1
202	SA31.A.03-00	base plate set	1
203	SA31.A.02-00	handle set	1
204	SA31.P.01-00	hoop set	2
205		right & left housing	1

19