

Operator's Manual

CRAFTSMAN[®]

12 in. SLIDING COMPOUND MITER SAW WITH LASER TRAC[®] Model No. 137.212390

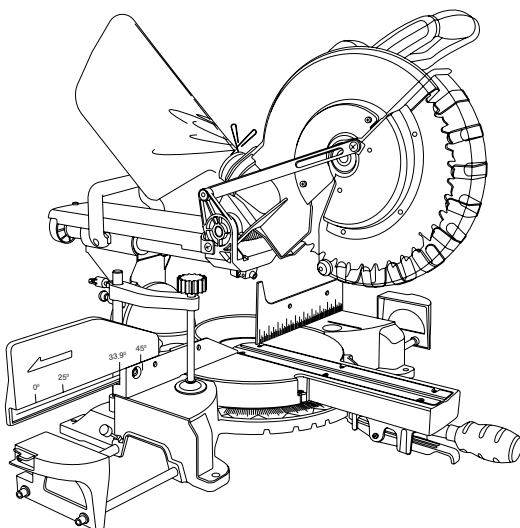

C US

CAUTION:

Before using this Miter Saw, read this manual and follow all its Safety Rules and Operating Instructions

- Safety Instructions
- Installation
- Operation
- Maintenance
- Parts List

**Customer Help Line
For Technical Support
1-800-843-1682**

**Sears Parts &
Repair Center
1-800-488-1222**

Sears, Roebuck and Co., Hoffman Estates, IL 60179 USA
Visit our Craftsman website: www.sears.com/craftsman
Part No. 137212390001

Printed in China

TABLE OF CONTENTS

SECTION	PAGE
Warranty	2
Product Specifications	3
Symbols.....	4
Power Tool Safety	5
Compound Miter Saw Safety	8
Electrical Requirements and Safety	9
Accessories and Attachments	12
Tools Needed for Assembly	13
Carton Contents	14
Know Your Compound Miter Saw	15
Glossary of Terms	16
Assembly and Adjustments	18
Operation	28
Maintenance	40
Troubleshooting Guide	42
Parts List	44

WARNING

Some dust created by using power tools contains chemicals known to the state of California to cause cancer and birth defects or other reproductive harm.

Some examples of these chemicals are:

- **Lead from lead-based paints**
- **Crystalline silica from bricks, cement and other masonry products**
- **Arsenic and chromium from chemically treated lumber**

Your risk from these exposures varies, depending on how often you do this type of work. To reduce your exposure to these chemicals, work in a well ventilated area and work with approved safety equipment such as dust masks that are specially designed to filter out microscopic particles.

WARNING

To avoid electrical hazards, fire hazards or damage to the tool, use proper circuit protection.

This tool is wired at the factory for 110-120 Volt operation. It must be connected to a 110-120 Volt / 15 Ampere time delay fuse or circuit breaker. To avoid shock or fire, replace power cord immediately if it is worn, cut or damaged in any way.

Before using your tool, it is critical that you read and understand these safety rules. Failure to follow these rules could result in serious injury to you or damage to the tool.

WARRANTY

CRAFTSMAN ONE YEAR FULL WARRANTY

If this Craftsman tool fails due to a defect in material or workmanship within one year from the date of purchase, call 1-800-4-MY-HOME[®] to arrange for free repair (or replacement if repair proves impossible).

This warranty applies for only 90 days from the date of purchase if this product is ever used for commercial or rental purposes.

This warranty does not include expendable parts, such as lamps, batteries, bits or blades.

This warranty gives you specific legal rights, and you may also have other rights which vary from state to state.

Sears, Roebuck and Co., Hoffman Estates, IL 60179

PRODUCT SPECIFICATIONS

MOTOR

Power Source	120V AC, 60Hz, 15 Amp
Speed	4200 RPM (No load)
Brake	Electric
Double Insulated.....	Yes
Motor Arbor Shaft Size.....	5/8 in.

BLADE SIZE

Diameter.....	12 in.
Arbor size.....	1 in. w/a 5/8 in. reducer

Rotating Table:

Diameter.....	11-13/16 in.
Miter Detent Stops	0, 15, 22.5, 31.6, 45° R & L
Bevel Positive Stops.....	0, 33.9, 45° L

Cutting Capacity:

Crosscut.....	4 in. x 12-1/4 in.
Miter 45° R & L.....	4 in. x 8-3/4 in. R & L
Bevel 45° L.....	2-1/2 in. x 12-1/4 in. L
45° Miter and 45° Bevel	2-1/2 in. x 8-3/4 in.

SYMBOLS

WARNING ICONS

Your power tool and its Owner's Manual may contain "WARNING ICONS" (a picture symbol intended to alert you to, and/or instruct you how to avoid, a potentially hazardous condition). Understanding and heeding these symbols will help you operate your tool better and safer. Shown below are some of the symbols you may see.



SAFETY ALERT: Precautions that involve your safety.



PROHIBITION



WEAR EYE PROTECTION: Always wear safety goggles or safety glasses with side shields.



READ AND UNDERSTAND INSTRUCTION MANUAL: To reduce the risk of injury, user and all bystanders must read and understand instruction manual before using this product.



KEEP HANDS AWAY FROM BLADE: Failure to keep your hands away from the blade will result in serious personal injury.



SUPPORT AND CLAMP WORK



DANGER: indicates an imminently hazardous situation which, if not avoided, will result in death or serious injury.



WARNING: indicates a potentially hazardous situation which, if not avoided, could result in death or serious injury.



CAUTION: indicates a potentially hazardous situation which, if not avoided, may result in minor or moderate injury.



CAUTION: used without the safety alert symbol indicates a potentially hazardous situation which, if not avoided, may result in property damage.

POWER TOOL SAFETY

GENERAL SAFETY INSTRUCTIONS BEFORE USING THIS POWER TOOL

Safety is a combination of common sense, staying alert and knowing how to use your power tool.

CAUTION

To avoid mistakes that could cause serious injury, do not plug the tool in until you have read and understood the following.

-  **READ** and become familiar with the entire Operator's Manual. **LEARN** the tool's application, limitations and possible hazards.
- KEEP GUARDS IN PLACE** and in working order.
- REMOVE ADJUSTING KEYS AND WRENCHES.** Form the habit of checking to see that keys and adjusting wrenches are removed from the tool before turning ON.
- KEEP WORK AREA CLEAN.** Cluttered areas and benches invite accidents.
- DO NOT USE IN DANGEROUS ENVIRONMENTS.** Do not use power tools in damp locations, or expose them to rain or snow. Keep work area well lit.

- KEEP CHILDREN AWAY.** All visitors and bystanders should be kept a safe distance from work area.
- MAKE WORKSHOP CHILD PROOF** with padlocks, master switches or by removing starter keys.
- DO NOT FORCE THE TOOL.** It will do the job better and safer at the rate for which it was designed.
- USE THE RIGHT TOOL.** Do not force the tool or an attachment to do a job for which it was not designed.
- USE PROPER EXTENSION CORDS.** Make sure your extension cord is in good condition. When using an extension cord, be sure to use one heavy enough to carry the current your product will draw. An undersized cord will result in a drop in line voltage and in loss of power which will cause the tool to overheat. The table on page 11 shows the correct size to use depending on cord length and nameplate ampere rating. If in doubt, use the next heavier gauge. The smaller the gauge number, the heavier the cord.
- WEAR PROPER APPAREL.** Do not wear loose clothing, gloves, neckties, rings, bracelets or other jewelry which may get caught in moving parts. Nonslip footwear is recommended. Wear protective hair covering to contain long hair.

POWER TOOL SAFETY

12. ALWAYS WEAR EYE



PROTECTION. Any power tool can throw foreign objects into the eyes and could cause permanent

eye damage. **ALWAYS** wear Safety Goggles (not glasses) that comply with ANSI Safety standard Z87.1. Everyday eyeglasses have only impact-resistant lenses. They **ARE NOT** safety glasses. Safety Goggles are available at Sears.

NOTE: Glasses or goggles not in compliance with ANSI Z87.1 could seriously injure you when they break.

13. WEAR A FACE MASK OR DUST MASK. Sawing operation produces dust.

14. SECURE WORK. Use clamps or a vise to hold work when practical. It is safer than using your hand and it frees both hands to operate the tool.



15. DISCONNECT TOOLS FROM POWER SOURCE before servicing, and when changing accessories such as blades, bits and cutters.

16. REDUCE THE RISK OF UNINTENTIONAL STARTING. Make sure switch is in the OFF position before plugging the tool in.

17. USE RECOMMENDED ACCESSORIES. Consult this Operator's Manual for recommended accessories. The use of improper accessories may cause risk of injury to yourself or others.

18. NEVER STAND ON THE TOOL. Serious injury could occur if the tool is tipped or if the cutting tool is unintentionally contacted.

19. CHECK FOR DAMAGED PARTS. Before further use of the tool, a guard or other part that is damaged should be carefully checked to determine that it will operate properly and perform its intended function – check for alignment of moving parts, binding of moving parts, breakage of parts, mounting and any other conditions that may affect its operation. A guard or other part that is damaged should be properly repaired or replaced.

20. NEVER LEAVE THE TOOL RUNNING UNATTENDED. TURN THE POWER "OFF". Do not walk away from a running tool until the blade comes to a complete stop and the tool is unplugged from the power source.

21. DO NOT OVERREACH. Keep proper footing and balance at all times.

POWER TOOL SAFETY

22. MAINTAIN TOOLS WITH CARE.

Keep tools sharp and clean for best and safest performance. Follow instructions for lubricating and changing accessories.

23. **WARNING:** Dust generated from certain materials can be hazardous to your health. Always operate saw in well-ventilated area and provide for proper dust removal.

24.



DANGER

People with electronic devices, such as pacemakers, should consult their physician(s) before using this product. Operation of electrical equipment in close proximity to a heart pacemaker could cause interference or failure of the pacemaker.

COMPOUND MITER SAW SAFETY

SPECIFIC SAFETY INSTRUCTIONS FOR THIS COMPOUND MITER SAW

1. **DO NOT** operate the miter saw until it is completely assembled and installed according to these instructions.
2. **IF YOU ARE NOT** thoroughly familiar with the operation of miter saws, seek guidance from your supervisor, instructor or other qualified person.
3. **ALWAYS** hold the work firmly against the fence and table. **DO NOT** perform any operation free hand (use clamp wherever possible).
4. **KEEP HANDS** out of the path of the saw blade. If the workpiece you are cutting would cause your hands to be within 8-3/4 in. of the saw blade, the workpiece should be clamped in place before making the cut.
5. **BE SURE** the blade is sharp, runs freely and is free of vibration.
6. **ALLOW** the motor to come up to full speed before starting a cut.
7. **KEEP THE MOTOR AIR SLOTS CLEAN** and free of chips or dust.
8. **ALWAYS MAKE SURE** all handles are tight before cutting, even if the table is positioned in one of the positive stops.
9. **BE SURE** both the blade and the collar are clean and the arbor bolt is tightened securely.
10. **USE** only blade collars specified for your saw.
11. **NEVER** use blades larger in diameter than 12 inches.
12. **NEVER** apply lubricants to the blade when it is running.
13. **ALWAYS** check the blade for cracks or damage before operation. Replace a cracked or damaged blade immediately.
14. **NEVER** use blades recommended for operation at less than 4200 RPM.
15. **ALWAYS** keep the blade guards in place and use at all times.
16. **NEVER** reach around the saw blade.
17. **MAKE SURE** the blade is not contacting the workpiece before the switch is turned ON.
18. **IMPORTANT:** After completing the cut, release the trigger and wait for the blade to stop before returning the saw to the raised position.
19. **MAKE SURE** the blade has come to a complete stop before removing or securing the workpiece, changing the workpiece angle or changing the angle of the blade.
20. **NEVER** cut metals or masonry products with this tool. This miter saw is designed for use on wood and wood-like products.

21. **NEVER** cut small pieces. If the workpiece being cut would cause your hand or fingers to be within 8-3/4 in. of the saw blade the workpiece is too small.
22. **PROVIDE** adequate support to the sides of the saw table for long work pieces.
23. **NEVER** use the miter saw in an area with flammable liquids or gases.
24. **NEVER** use solvents to clean plastic parts. Solvents could possibly dissolve or otherwise damage the material.
25. **SHUT OFF** the power before servicing or adjusting the tool.
26. **DISCONNECT** the saw from the power source and clean the machine when finished using.
27. **MAKE SURE** the work area is clean before leaving the machine.
28. **SHOULD** any part of your miter saw be missing, damaged, or fail in any way, or any electrical component fail to perform properly, lock the switch and remove the plug from the power supply outlet. Replace missing, damaged, or failed parts before resuming operation.

ELECTRICAL REQUIREMENTS

POWER SUPPLY AND MOTOR SPECIFICATIONS

The AC motor used in this saw is a universal, nonreversible type. See “MOTOR” in the “PRODUCT SPECIFICATIONS” section on page 2.

WARNING

To avoid electrical hazards, fire hazards, or damage to the tool, use proper circuit protection. Your saw is wired at the factory for 120 V operation. Connect to a 120 V, 15 A circuit and use a 15 A time delay fuse or circuit breaker. To avoid shock or fire, if power cord is worn or cut, or damaged in any way, have it replaced immediately.

ELECTRICAL REQUIREMENTS AND SAFETY

ELECTRICAL REQUIREMENTS – cont'd

DOUBLE INSULATED

The power tool is double insulated to provide a double thickness of insulation between you and tool's electrical system. All exposed metal parts are isolated from the internal metal motor components with protecting insulation.

Replacement parts – When servicing, use only identical replacement parts.

Polarized plugs – This saw has a plug that looks like the one shown below:

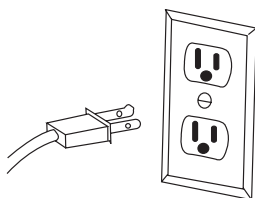

To reduce the risk of electrical shock, this saw has a polarized plug (one blade is wider than the other). This plug will fit in a polarized outlet only one way. If the plug does not fit fully in the outlet, reverse the plug. If it still does not fit, contact a qualified electrician to install the proper outlet. Do not change the plug in any way.

WARNING

Double insulation does not take the place of normal safety precautions when operating this tool.

To avoid electrocution:

1. Use only identical replacement parts when servicing a tool with double insulation. Servicing should be performed by a qualified technician.
2. Do not use power tools in wet or damp locations or expose them to rain or snow.

MOTOR SAFETY PROTECTION IMPORTANT

To avoid motor damage, the motor should be blown out or vacuumed frequently to keep sawdust from interfering with the motor ventilation.

1. **Connect** this saw to a 120 V circuit. This circuit must not be less than a #12 wire with a 20 A time lag fuse or a #14 wire with a 15 A time lag fuse. **NOTE:** When using an extension cord on a circuit with a #14 wire, the extension cord must not exceed 25 feet in length.
2. If the motor will not start, release the trigger switch immediately. **UNPLUG THE SAW.** Check the saw blade to make sure it turns freely. If the blade is free, try to start the saw again. If the motor still does not start, refer to the **TROUBLESHOOTING GUIDE.**
3. If the tool suddenly stalls while cutting wood, release the trigger switch, unplug the tool and free the blade from the wood. The saw may now be started and the cut finished.
4. **FUSES** may “blow” or circuit breakers may trip frequently if:
 - a. **MOTOR** is overloaded – overloading can occur if you feed

ELECTRICAL REQUIREMENTS AND SAFETY

too rapidly or make too many start/stops in a short time.

- b. **LINE VOLTAGE** is more than 10% above or below the nameplate voltage rating. For heavy loads, the voltage at motor terminals must equal the voltage specified on the nameplate.
 - c. **IMPROPER** or dull saw blades are used.
5. Most motor troubles may be traced to loose or incorrect connections, overload, low voltage or inadequate power supply wiring. Always check the connections, the load and supply circuit if the motor doesn't run well. Check minimum gauge for the length of cord you are using on the chart below.

GUIDELINES FOR EXTENSION CORDS

Use a proper extension cord. Make sure your extension cord is in good condition. When using an extension cord, be sure to use one heavy enough to carry the current your product will draw. An undersized cord will cause a drop in line voltage, resulting in loss of power and overheating. The table below shows the correct size to use depending on cord length and nameplate ampere rating. If in doubt, use the next heavier gauge. The smaller the gauge number, the heavier the cord.

Be sure your extension cord is properly wired and in good condition. Always replace a damaged extension

cord or have it repaired by a qualified person before using it. Protect your extension cords from sharp objects, excessive heat and damp or wet areas.

Use a separate electrical circuit for your tools. This circuit must not be less than a #12 wire with a 20 A time lag fuse or a #14 wire with a 15 A time lag fuse. **NOTE:** When using an extension cord on a circuit with a #14 wire, the extension cord must not exceed 25 feet in length. Before connecting the tool to the power line, make sure the switch is in the OFF position and the electric current is rated the same as the current stamped on the motor nameplate, running at a lower voltage will damage the motor.

MINIMUM GAUGE FOR EXTENSION CORDS (AWG)

(When using 120 volts only)				
Ampere Rating		Total length of Cord		
More Than	Not More Than	25ft.	50ft.	100ft. 150ft.
0	6	18	16	14
6	10	18	16	14 12
10	12	16	16	14 12
12	16	14	12	Not Recommended

CAUTION: In all cases make certain the receptacle in question is properly grounded. If you are not sure, have a certified electrician check the receptacle.

ACCESSORIES AND ATTACHMENTS

RECOMMENDED ACCESSORIES

WARNING

- Use only accessories recommended for this miter saw. Follow instructions that accompany accessories. Use of improper accessories may cause hazards.
- The use of any cutting tool except 12 in. saw blades which meet the requirements under recommended accessories is prohibited. Do not use accessories such as shaper cutters or dado sets. Ferrous metal cutting and the use of abrasive wheels is prohibited.
- Do not attempt to modify this tool or create accessories not recommended for use with this tool. Any such alteration or modification is misuse and could result in a hazardous condition leading to possible serious injury.

WARNING

Read warnings and conditions on your **CARBIDE TIPPED SAW BLADE**. Do not operate the saw without the proper saw blade guard in place. Carbide is a very hard but brittle material. Care should be taken while mounting, using, and storing carbide tipped blades to prevent accidental damage. Slight shocks, such as striking the tip while handling, can seriously damage the blade. Foreign objects in the workpiece, such as wire or nails, can also cause tips to crack or break off. Before using, always visually examine the blade and tips for bent blade, cracks, breakage, missing or loose tips, or other damage. Do not use if damage is suspected. Failure to heed safety instructions and warnings can result in serious bodily injury.

ACCESSORIES

Visit your Sears Hardware Department or see the Sears Power and Hand Tool Catalog to purchase recommended accessories for this power tool.

WARNING

To avoid the risk of personal injury, do not modify this power tool or use accessories not recommended by Sears.

TOOLS NEEDED FOR ASSEMBLY

Supplied



Blade Wrench

Not supplied



Adjustable Wrench



Hex Key



Combination Square



Phillips Screwdriver



Slotted Screwdriver

COMBINATION SQUARE MUST BE TRUE

Should not gap or overlap when square is flipped over (see dotted figure).

Draw light line on board along this edge.

Straight edge or a 3/4 in. board, this edge must be perfectly straight.

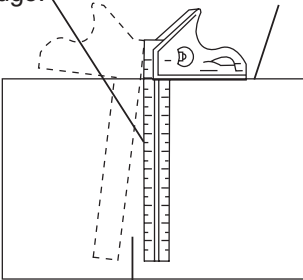

Should not gap or overlap when square flipped over (see dotted figure).

CARTON CONTENTS

UNPACKING YOUR MITER SAW

⚠ WARNING

To avoid injury from unexpected starting or electrical shock, do not plug the power cord into a source of power during unpacking and assembly. This cord must remain unplugged whenever you are working on the saw.

1. Remove the miter saw from the carton.

IMPORTANT: Do not lift miter saw by the trigger switch handle. It may cause misalignment. Lift machine by the built-in carry handle.

2. Place the saw on a secure stationary work surface.
3. Separate all parts from the packing material. Check each one with the illustration to make certain all items are accounted for, before discarding any packing material.

⚠ WARNING

If any part is missing or damaged, do not attempt to assemble the miter saw, or plug in the power cord until the missing or damaged part is correctly replaced. To avoid electric shock, use only identical replacement parts when servicing double insulated tools. Call 1-800-4-MY-HOME® for replacement parts.

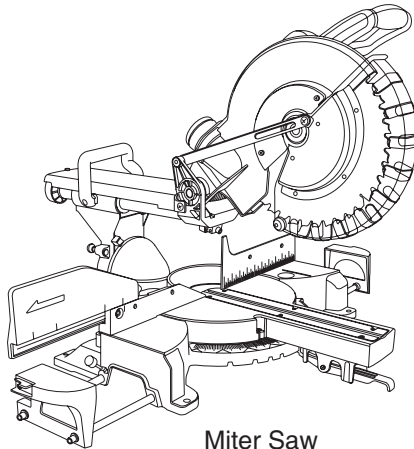

Miter Saw

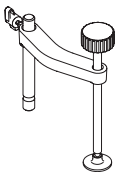

Hold-down Clamp

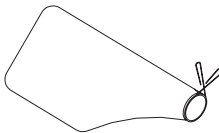

Dust Bag

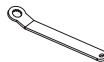

Blade Wrench

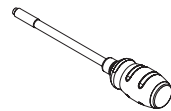

Miter Handle

KNOW YOUR SLIDING MITER SAW

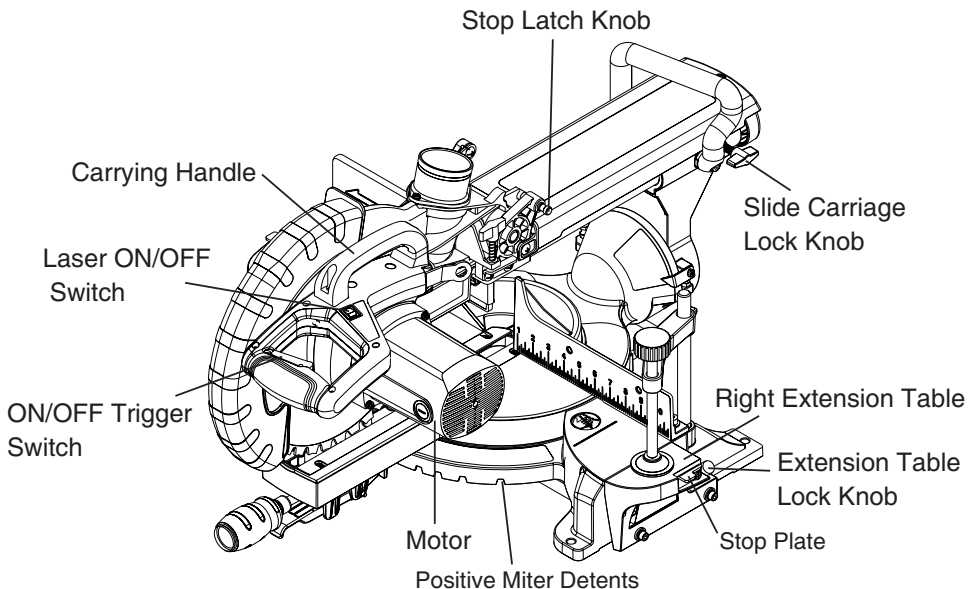
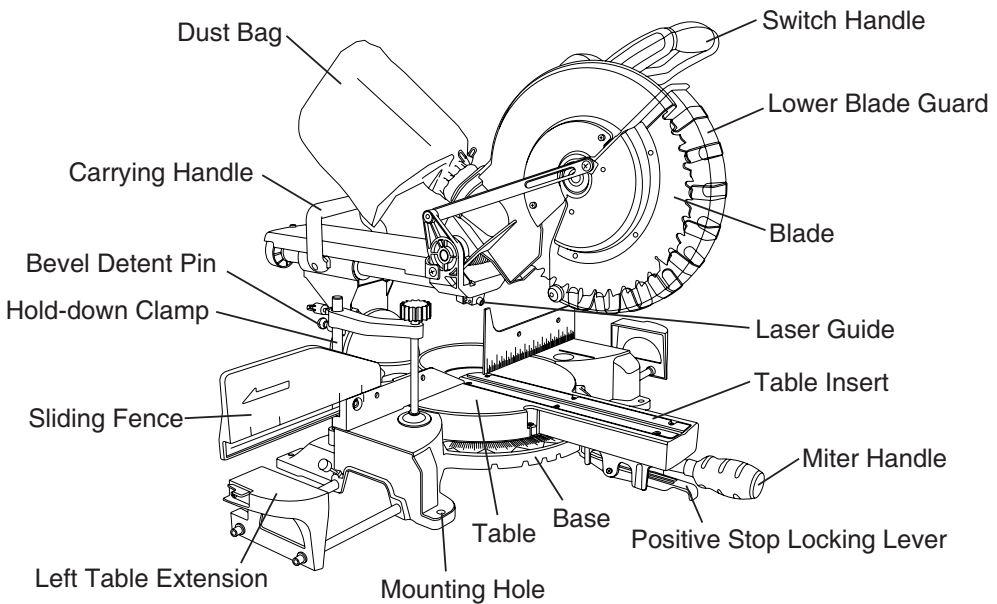

GLOSSARY OF TERMS

AMPERAGE (AMPS) – A measure of the flow of electric current. Higher ratings generally means the tool is suited for heavier use.

ARBOR LOCK – Allows the user to keep the blade from rotating while tightening or loosening the arbor bolt during blade replacement or removal.

BASE – Supports the table, holds accessories and allows for workbench or leg set mounting.

BEVEL LOCKING HANDLE – Locks the miter saw at a desired bevel angle.

BEVEL SCALE – To measure the bevel angle of the saw blade 0° to 45° left.

CARBIDE TIPPED – Extremely hard steel pieces with sharp cutting edges fastened to cutting tools such as saw blades.

COVER PLATE SCREW – Loosen this screw and rotate the plate for access to the blade arbor bolt.

DOUBLE-INSULATED – A form of electrical protection featuring two separate insulation systems to help protect against electrical shock.

EXTENSION CORD – AN electric cord used between power tools and outlets to extend the range of the tools. The more amperage your tool uses, the longer the distance, the larger the size of the wire needed in your extension cord.

EYE PROTECTION – Goggles or spectacles intended to protect your eyes. Eye protection should meet the

requirements of ANSI Z.87.1 (USA) or CSA Z94.3-M88 (Canada).

FACE SHIELD – An impact resistant shield that helps to protect your face from chips, sparks, small debris. Should only be used in conjunction with additional eye protection.

FENCE – Helps to keep the workpiece from moving when sawing. Scaled to assist with accurate cutting.

GUARD – Protective device that forms a barrier between a hazardous object such as a blade, wheel or cutter and the operator.

HOLD DOWN LATCH – Locks the miter saw in the lowered position for compact storage and transportation.

INSTRUCTION OR OWNER'S MANUAL – Booklet accompanying your power tool that describes the hazards and safe operation procedures, outlines basic tool operation, care and maintenance.

MITER HANDLE – Used to rotate the table, and to rotate the saw to a right or left cutting position.

MITER SCALE – Measures the miter angle 0° to 45° left and right.

MOUNTING HOLES – To mount the miter saw to a stable surface.

ON/OFF TRIGGER SWITCH – To start the tool, push the safety lock-off button and squeeze the trigger. Release the trigger to turn off the miter saw.

GLOSSARY OF TERMS

POSITIVE STOP LOCKING LEVER – Locks the miter saw at a preset positive stop for the desired miter angle.

SWITCH HANDLE – The switch handle contains the trigger switch and safety lock-off button. The blade is lowered into the workpiece by pushing down on the handle. The saw will return to its upright position when the handle is released.

WARNING LABELS – Read and understand for your own safety. Make sure all labels are present on machine and legible.

WRENCH STORAGE – Convenient storage to prevent misplacing the blade wrench.

WOODWORKING TERMS

ARBOR – The shaft on which a blade is mounted.

BEVEL CUT – An angle cut made through the face of the workpiece.

COMPOUND CUT – An angled cut to both the edge and face of a board, most common use is with crown molding.

CROSS CUT – A cut which runs across the board perpendicular to the grain.

FREEHAND – Performing a cut without using a fence (guide), hold down or other proper device to prevent the workpiece from twisting during the cutting operation.

HEEL – Misalignment of the blade.

KERF – The width of a saw cut, determined by the thickness and set of the blade.

KICKBACK – sudden and unintended movement of the tool or workpiece. It is typically caused by binding or pinching of the workpiece

MITER CUT – A miter is a type of joint where the two parts to be joined are cut at an angle, and typically the finished joint forms a 90-degree angle. Also commonly spelled “miter”.

REVOLUTIONS PER MINUTE (RPM) – The number of turns completed by a spinning object in one minute.

SAW BLADE PATH – The area of the workpiece or table top directly in line with the travel of the blade or the part of the workpiece which will be cut.

SET – The distance between two saw blade tips, bent outward in opposite directions to each other. The further apart the tips are, the greater the set.

THIN-KERF BLADE – Thinner than normal blades, remove less material, smaller kerfs (between .065 and .070). Blade thinness also may increase the heat generated while cutting.

WORKPIECE – The wood being cut. The surfaces of a workpiece are commonly referred to as faces, ends and edges.

ASSEMBLY AND ADJUSTMENTS

Estimated Assembly Time: 5 – 10 minutes

▲ WARNING

To avoid injury, do not connect this miter saw to the power source until it is completely assembled and adjusted and you have read and understood this Operator's Manual.

INSTALLING THE MITER HANDLE (FIG. A)

1. Thread the miter handle (1) into the hole located at the front of the miter table.

Fig. A

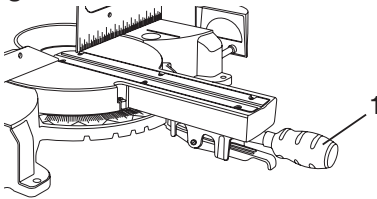

UNLOCKING THE SLIDE CARRIAGE (FIG. B)

After removing the saw from the carton, loosen the slide carriage lock knob (1). When transporting or storing the miter saw, the slide carriage should always be locked in position. The slide carriage lock knob (1) is located on the right side of the slide carriage.

Fig. B

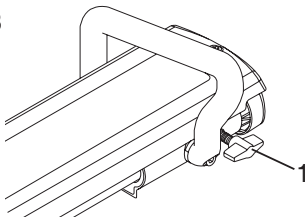

SAW BLADE WRENCH (FIG. C)

1. For convenient storage and prevention of loss, there is a slot (1) in the rear of the carrying handle (2) for storing the blade wrench (3) when not in use.

Fig. C

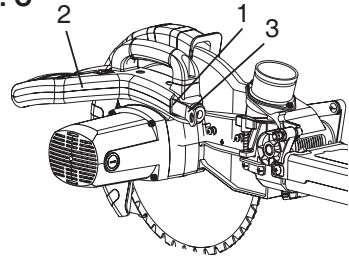

RELEASING CUTTING HEAD (FIG. D) Unlocking

▲ WARNING

To avoid injury and damage to the saw, transport and store the miter saw with the cutting head locked in the down position. Never use the stop latch to hold the cutting head in a down position for cutting operations.

1. Push down slightly on the switch handle (1).
2. Pull out the stop latch knob (2).
3. Allow the cutting head to rise to the up position.

Fig. D

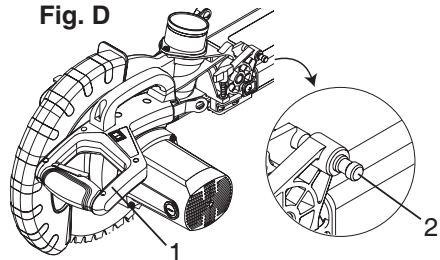

Locking

When transporting or storing the miter saw, the cutting head should always be locked in the down position.

1. Push the cutting head down to its lowest position.
2. Push the stop latch knob (2) into the locking hole.

IMPORTANT: To avoid damage, never carry the miter saw by the switch handle, the cutting arm or the miter handle. ALWAYS use the designated carrying handles located on the top of the machine and in the back of the unit.

INSTALLING THE EXHAUST PORT AND THE DUST BAG (FIG. E)

1. Squeeze the metal collar wings (2) of the dust bag (1).
2. Place the dust bag neck opening around the exhaust port (3), and release the metal collar wings.

Fig. E

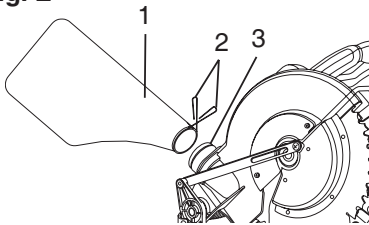

To empty the dust bag, squeeze the metal collar and remove from exhaust port. Open zipper on underside of bag and empty into waste container.

NOTE: Check frequently and empty bag before it gets full.

INSTALLING THE HOLD-DOWN CLAMP (FIG. F and G)

1. Place the hold-down clamp assembly (1) in one of the mounting holes (2), located behind the fence.

NOTE: There are no screws to secure clamp. The clamp will secure itself to the base when turning the

knob (3) to clamp the workpiece. Do not use your other hand to hold the clamp when tightening. Only turn knob (3) to secure clamp to table. The clamp will tilt at an angle and secure itself when tightened.

Fig. F

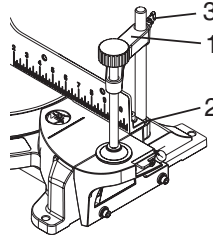
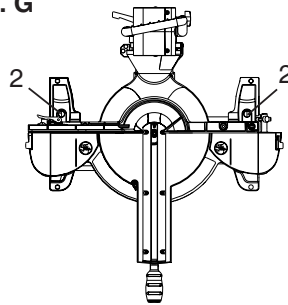

Fig. G



REMOVING AND INSTALLING THE TABLE INSERT (FIG. H)

▲ WARNING

To avoid injury:

- Always unplug the saw to avoid accidental starting. Remove all small pieces of material from the table cavity before performing any cuts. The table insert may be removed for this purpose, but always reattach the table insert prior to performing a cutting operation.
- Do not start the sliding compound miter saw without checking for interference between the blade and table insert. Damage could result to the blade, table insert or turntable if blade strike occurs during the cutting operation.

1. Loosen the miter handle (1). Lift up the positive stop locking lever (2) and position the table to left 15°. Release the positive stop locking lever and lock the miter handle.
2. The sliding fence (3) must be extended to the left.
3. To remove, loosen and remove the six screws (4) on the table inserts (5) with a Phillips screwdriver and remove the insert.
4. To install, reposition the table insert, install the six screws and tighten.
5. Check for blade clearance by moving the slide carriage through the full motion of the blade in the table slot.

Fig. H

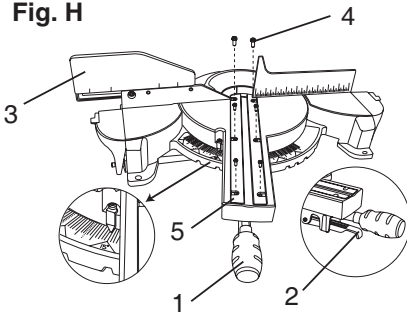

MOUNTING THE MITER SAW (FIG. I, J)

⚠ WARNING

To avoid injury from unexpected saw movement:

- Disconnect the power cord from the outlet, and lock the cutting head in the lower position using the stop latch.
- Lock the slide carriage in place by tightening the slide carriage lock knob.
- To avoid back injury, lift the saw by using the designated carrying

handles located on the top of the machine. When lifting, bend at your knees, not from your back.

- Never carry the miter saw by the power cord or by the switch handle. Carrying the tool by the power cord could cause damage to the insulation or the wire connections resulting in electric shock or fire.
- To avoid injury from flying debris, do not allow visitors to stand near the saw during any cutting operation.
- Support the saw on a level work surface.
- Bolt or clamp the saw to its support.

Mounting instructions

1. For stationary use, place the saw in the desired location, directly on a workbench where there is room for handling and proper support of the workpiece. The base of the saw has four mounting holes. Bolt the base of the miter saw (1) to the work surface (5), using the fastening method as shown in Fig I.

Fig. I

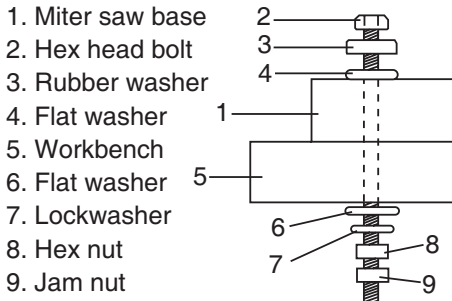

NOTE: Mounting hardware is not included with this tool. Bolts, nuts, washers and screws must be purchased separately.

2.  **For portable use**, place the saw on a 3/4 in. thick piece of plywood. Bolt the base of the miter saw securely to the plywood using the mounting holes on the base. Use C-clamps to clamp this mounting board to a stable work surface at the worksite.

Fig. J



REMOVING OR INSTALLING THE BLADE

Removing Blade (Fig. K, L and M)

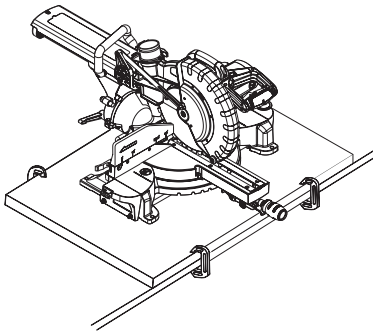
WARNING

- To avoid injury from an accidental start, make sure the switch is in the OFF position and plug is not connected to the power source outlet.
- Only use a 12-inch diameter blade.

1. Unplug the saw from the outlet
2. Raise the miter saw to the upright position.
3. Raise the lower clear plastic blade guard (1) to the uppermost position. (Fig. K)

4. While holding the lower blade guard, loosen the cover plate screw (2) with a Phillips screwdriver. (Fig. K)
5. Rotate the cover plate (3) to expose the arbor bolt (4). (Fig. K)
6. Place the blade end wrench over the arbor bolt.

Fig. K

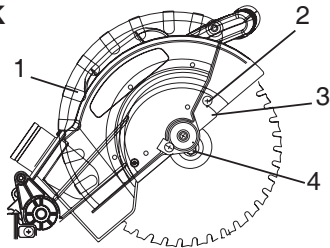

7. Locate the arbor lock (5) on the motor. (Fig. L)
8. Press the arbor lock, holding it in firmly while turning the blade clockwise. The arbor lock will then engage and lock the arbor. Continue to hold the arbor lock, while turning the wrench clockwise to loosen the arbor bolt.

Fig. L

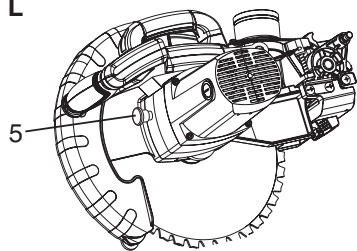

9. Remove the arbor bolt (4), the arbor collar (6), and the blade (7). Do not remove the inner blade collar. (Fig. M)
10. Raise the lower clear plastic blade guard (1) to the upright position (Fig. K) to remove the blade.

NOTE: Pay attention to the pieces removed, noting their position and direction they face. Wipe the blade collars clean of any sawdust before installing a new blade. Also, the 12 in. blade has a 1 in. arbor hole with a 5/8 in. reducer (8) to mount onto the saw.

Fig. M

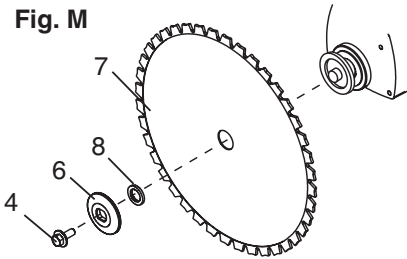

INSTALLING BLADE (FIG. K, L, M)

▲ WARNING

Un-plug the miter saw before changing/installing the blade.

1. Install a 12 in. blade with a 5/8 in. arbor (or a 1 in. arbor with a 5/8 in. reducer) making sure the rotation arrow on the blade matches the clockwise rotation arrow on the upper guard, and the blade teeth are pointing downward.
2. Place the arbor collar (6) against the blade and on the arbor. Thread the arbor bolt (4) on the arbor (Fig. M) in a counterclockwise direction. **IMPORTANT:** Make sure the flats of the blade collars are engaged with the flats on the arbor shaft. Also, the flat-side of the arbor collar must be placed against the blade.
3. Place the blade wrench on the arbor bolt.

4. Press the arbor lock (5), holding it in firmly while turning the blade counterclockwise. When it engages, continue to press the arbor lock in, while tightening the arbor bolt securely. (Fig. L)
5. Rotate the cover plate (3) back to its original position until the slot in the cover plate engages with the cover plate screw (2). While holding the lower blade guard, tighten the screw with a Phillips screwdriver. (Fig. K) **NOTE:** The lower blade guard must be raised to the upright position to access the cover plate screw.
6. Lower the clear retractable blade guard (1) and verify the operation of the guard does not bind or stick (Fig. K).
7. Be sure the arbor lock is released so the blade turns freely by spinning the blade until the arbor lock disengages.

▲ WARNING

- **To avoid injury, never use the saw without the cover plate secure in place. It keeps the arbor bolt from falling out if it accidentally loosens, and helps prevent the spinning blade from coming off the saw.**
- **Make sure the collars are clean and properly arranged. Lower the blade into the table and check for any contact with the metal base or the turn table.**

THE LASER BEAM

WARNING

For your own safety, never connect the plug to power source outlet until all the adjustment steps are complete and you have read and understood the safety and operational instructions.

Your tool is equipped with the Laser Trac[®] cutting guide using Class II laser beam. The laser beam will enable to preview the saw blade path on the stock to be cut before starting the miter saw. This laser guide is powered by the transformed alternating current supply directly through the power lead. **The saw must be connected to the power source and the laser on/off switch must be turned on for the laser line to show.**

WARNING

- **AVOID DIRECT EYE CONTACT**
Laser radiated when laser guide is turned on. Avoid direct eye contact. Always un-plug the miter saw from power source before making any adjustments.
- **Laser Warning Label: Max output <1mW DIODE LASER: 630-670 nm, Complies with 21CFR 1040.10 and 1040.11.**
CLASS II LASER PRODUCT.

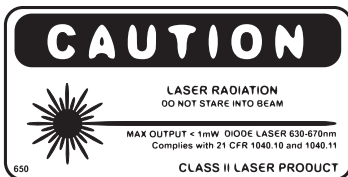

- **NOTE: All the adjustments for the operation of this machine have been completed at the factory. Due to normal wear and use, some occasional readjustments may be necessary.**
- **CAUTION-Use of controls or adjustments or performance of procedures other than those specified herein may result in hazardous radiation exposure.**
- **CAUTION-The use of optical instruments with this product will increase eye hazard.**
- **Do not attempt to repair or disassemble the laser. If unqualified persons attempt to repair this laser product, serious injury may result. Any repair required on this laser product should be performed by authorized service center personnel.**

BEVEL STOP ADJUSTMENT



WARNING

To avoid injury from an accidental start, make sure the switch is in the OFF position and the plug is not connected to the power source outlet.

90° (0°) Bevel adjustment (Fig. N)

1. Loosen bevel lock handle (1) and tilt the cutting arm completely to the right. Tighten the bevel lock handle.
2. Place a combination square (2) on the miter table with the ruler against the table and the heel of the square against the saw blade.
3. If the blade is not 90° (0°) square with the miter table (5), loosen the bevel lock handle (1), tilt the cutting head to the left, loosen the locknut (4) on the bevel angle adjustment bolt (3) and use a 10 mm wrench to adjust the stop bolt (3) depth in or out to increase or decrease the bevel angle.
4. Tilt the cutting arm to back to the right at 90° (0°) bevel and recheck for alignment.
5. Repeat steps 1 through 4 if further adjustment is needed.
6. Tighten bevel lock handle (1) and locknut (4) when alignment is achieved.

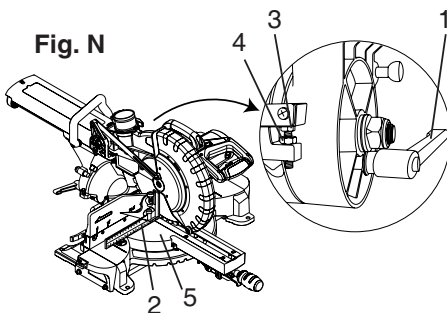

90° Bevel Pointer Adjustment (Fig. O)

1. When the blade is exactly 90° (0°) to the table, loosen the bevel indicator screw (5) using a # 2 Phillips screwdriver.
2. Adjust bevel indicator (6) to the "0" mark on the bevel scale and retighten the screw.

Fig. O

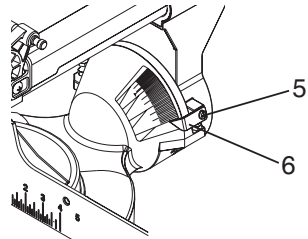

45° Bevel Adjustment (Fig. P)

1. Loosen the bevel lock handle (7) and tilt the cutting head completely to the left.
2. Using a combination square, check to see if the blade angle is 45° to the table.
3. If the blade is not at 45° to the miter table, tilt the cutting arm to the right, loosen the locknut (8) on the bevel angle adjustment bolt (9) and use a 10 mm wrench to adjust the stop bolt (9) depth in or out to increase or decrease the bevel angle.
4. Tilt the cutting arm to the left to 45° bevel and recheck for alignment.
5. Repeat steps 1 through 4 until the blade is at 45° to the miter table.
6. Tighten bevel lock handle (7) and locknut (8) when alignment is achieved.

Fig. P

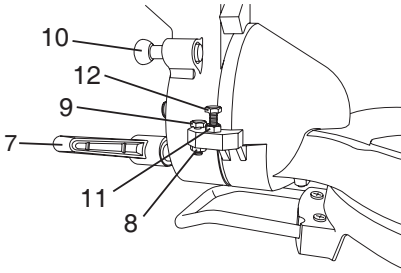

33.9° Bevel Adjustment (Fig. P)

1. Push the bevel detent pin (10) in toward the front of the unit.
2. Unlock the bevel lock handle and tilt the cutting arm to the crown molding positive stop at 33.9°.
3. Using a combination square, check to see if the blade angle is 33.9° to the table.
4. If the blade is not at 33.9° to the miter table, loosen locknut (11) and use a 10 mm wrench to adjust the bolt (12) in or out until the blade is at 33.9° to the miter table.
5. Secure the locknut (11) into position after alignment is achieved.

MITER ANGLE ADJUSTMENT (FIG. Q)

The sliding compound miter saw scale can be easily read, showing miter angles from 0° to 45° to the left, and 0° to 45° to the right. The miter saw table has nine of the most common angle settings with positive stops at 0°, 15°, 22.5°, 31.6°, and 45°. These positive stops position the blade at the desired angle quickly and accurately. Follow the process below for quickest and most accurate adjustments.

1. Unlock the miter table by turning the miter handle (1) counterclockwise.
2. Move the turntable while lifting up on the positive stop locking lever (2) to align the indicator (3) to the desired degree measurement.
3. If the desired angle is one of the nine positive stops, release the positive stop locking lever, making sure the lever snaps into position, and then secure by tightening the miter handle.
4. If the miter angle desired is not one of the nine positive stops, simply lock the miter table into position by turning the miter handle in the clockwise direction.

Fig. Q

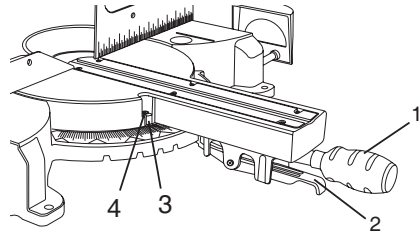

MITER SCALE INDICATOR ADJUSTMENT (FIG. Q)

1. Move the table to the 0° positive stop.
2. Loosen the screw (4) that holds the indicator with a Phillips screwdriver.
3. Adjust the indicator (3) to the 0° mark and retighten screw.

ADJUSTING FENCE SQUARENESS (FIG. R)

1. Loosen the three fence locking bolts (1).
2. Lower the cutting arm and lock in position.
3. Using a square (3), lay the heel of the square against the blade and the ruler against the fence (2) as shown.
4. Adjust the fence 90° to the blade and tighten the four fence locking bolts.

CAUTION: If the saw has not been used recently, recheck blade squareness to the fence and readjust if needed.

5. After fence has been aligned, using a scrap piece of wood, make a cut at 90° then check squareness on the piece. Readjust if necessary.

Fig. R

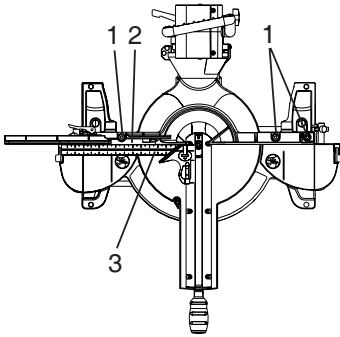

SETTING CUTTING DEPTH (FIG. S)

The depth of cut can be preset for even and repetitive shallow cuts.

1. Adjust the cutting head down (See CUTTING HEAD section) until the teeth of the blade are at the desired depth.

2. While holding the upper arm in that position, turn the stop knob (1) until it touches the stop plate (2).
3. Recheck the blade depth by moving the cutting head front to back through the full motion of a typical cut along the control arm.

Fig. S

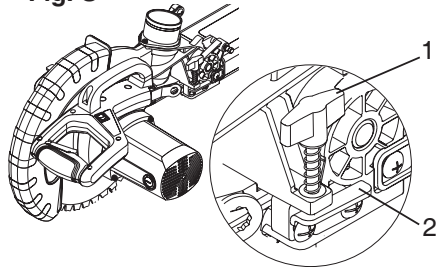

ADJUSTING CUTTING DEPTH (FIG. S)

The maximum depth travel of the cutting head was set at the factory. Check to see that the blade does not extend more than 1/4 in. below the table insert, and does not touch the control arm throat or any part of the base or table. If the maximum depth needs readjusting:

1. Loosen the stop knob (1) while moving the cutting head down until the blade extends just 1/4 in. below the table insert.
2. Adjust the stop knob (1) to touch the stop plate (2).
3. Recheck the blade depth by moving the cutting head front to back through the full motion of a cut along the control arm. If the blade touches the inside of the control arm, readjust the setting.

SLIDING THE REAR EXTENSION SUPPORT BAR (FIG. T)

⚠ WARNING

To avoid possible personal injury or damage to the miter saw due to tipping, do not operate the saw without the Rear Extension Support Bar.

Loosen the two screws (1) and extend the rear extension support bar (2) by sliding it out to match position, tighten the two screws.

Fig. T

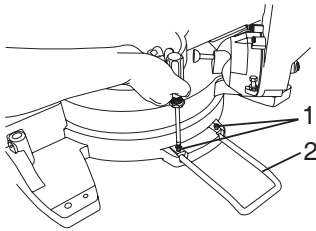

OPERATION

SAFETY INSTRUCTIONS FOR BASIC SAW OPERATION

BEFORE USING THE MITER SAW

WARNING

To avoid mistakes that could cause serious, permanent injury, do not plug the tool in until the following steps are completed:

- Completely assemble and adjust the saw, following the instructions. **(ASSEMBLY AND ADJUSTMENTS)**
- Learn the use and function of the ON/OFF switch, lock-off switch, upper and lower blade guards, hold down latch, bevel lock handle and cover plate screws.
- Review and understand all safety instructions and operating procedures in this Operator's Manual. **(SAFETY & OPERATIONS)**
- Review the **MAINTENANCE** and **TROUBLESHOOTING GUIDE** for your miter saw.
- To avoid injury or possible death from electrical shock: Make sure your fingers do not touch the plug's metal prongs when plugging or unplugging your miter saw. **(ELECTRICAL REQUIREMENTS AND SAFETY)**

BEFORE EACH USE INSPECT YOUR SAW.

- **Disconnect the miter saw.**
To avoid injury from accidental starting, unplug the saw before any

adjustments, including set-up and blade changes.

- **Compare the direction of rotation arrow** on the guard to the direction arrow on the blade. The blade teeth should always point downward at the front of the saw.
- **Tighten the arbor bolt.**
- **Tighten the cover plate screw.**
- **Check for damaged parts.** Check for:
 - Alignment of moving parts
 - Damaged electric cords
 - Binding of moving parts
 - Mounting holes
 - Function of arm return spring and lower guard: Push the cutting arm all the way down, then let it rise until it stops. The lower guard should fully close. Follow instructions in **TROUBLESHOOTING GUIDE** for adjustment if necessary.
- Other conditions that may affect the way the miter saw works.
- Keep all guards in place, in working order and proper adjustment. If any part of this miter saw is missing, bent, damaged or broken in any way, or any electrical parts don't work, turn the saw off and unplug it.
- Replace bent, damaged, missing or defective parts before using the saw again.
- Maintain tools with care. Keep the miter saw clean for best and safest performance. Follow instructions for lubricating. Do not put lubricants on the blade while it is spinning.

OPERATION

- Remove adjusting wrench from the tool before turning it on.
- To avoid injury from jams, slips, or thrown pieces, use only recommended accessories.

RECOMMENDED ACCESSORIES

- Consult the ACCESSORIES and ATTACHMENTS section of this Operators Manual for recommended accessories. Follow the instructions that come with the accessory. The use of improper accessories may cause risk of injury to persons.
- Choose the correct 12 in. diameter blade for the material and the type of cutting you plan to do. Do not use Thin Kerf blades.
- Make sure the blade is sharp, undamaged and properly aligned. With the saw unplugged, push the cutting arm all the way down. Manually spin the blade and check for clearance. Tilt the power-head to a 45° bevel and repeat the test.
- Make sure the blade and arbor collars are clean.
- Make sure all clamps and locks are tight and there is no excessive play in any parts.

KEEP YOUR WORK AREA CLEAN

Cluttered areas and benches invite accidents.

WARNING

To avoid burns or other fire damage, never use the miter saw near flammable liquids, vapors, or gases.

- Plan ahead to protect your eyes, hands, face and ears.
- Know your miter saw. Read and understand the Operator's Manual and labels affixed to the tool. Learn its application and limitations as well as the specific potential hazards peculiar to this tool. To avoid injury from accidental contact with moving parts, do not do layout, assembly, or setup work on the miter saw while any parts are moving.
- Avoid accidental starting, make sure the trigger switch is disengaged before plugging the miter saw into a power outlet.

PLAN YOUR WORK

- Use the right tool. Don't force a tool or attachment to do a job it was not designed to do. Use a different tool for any workpiece that can't be held in a solidly braced, fixed position.

CAUTION: This machine is not designed for cutting masonry, masonry products, ferrous metals (steel, iron, and iron-based metals.) Use this miter saw to cut only wood, wood-like products, or non-ferrous metals. Other material may shatter, bind the blade, or create other dangers. Remove all nails that may be in the workpiece to prevent sparking that could cause a fire. Remove dust bag when cutting non-ferrous metals.

OPERATION

DRESS FOR SAFETY



Any power tool can throw foreign objects into the eyes. This can result in permanent eye damage. Everyday eyeglasses have only impact resistant lenses and are not safety glasses. Glasses or goggles not in compliance with ANSI Z87.1 could seriously injure you when they break.

- Do not wear loose clothing, gloves, neckties or jewelry (rings, watches). They can get caught and draw you into moving parts.
- Wear non-slip footwear.
- Tie back long hair.
- Roll long sleeves above the elbow.
- Noise levels vary widely. To avoid possible hearing damage, wear ear plugs when using any miter saw.
- For dusty operations, wear a dust mask along with safety goggles.

INSPECT YOUR WORKPIECE

Make sure there are no nails or foreign objects in the part of the workpiece being cut.

Plan your work to avoid small pieces that may bind, or that are too small to clamp and get a solid grasp on. Plan the way you will grasp the workpiece from start to finish. Avoid awkward operations and hand positions. A sudden slip could cause your fingers or hand to move into the blade.

DO NOT OVER-REACH

Keep good footing and balance. Keep your face and body to one side, out of the line of a possible kickback. NEVER stand in the line of the blade.

Never cut freehand:

- Brace your workpiece firmly against the fence and table stop so it will not rock or twist during the cut.
- Make sure there is no debris between the workpiece and the table or fence.
- Make sure there are no gaps between the workpiece, fence and table that will let the workpiece shift after it is cut.
- Keep the cut off piece free to move sideways after it is cut off. Otherwise, it could get wedged against the blade and thrown violently.
- Only the workpiece should be on the saws table.
- Secure work. Use clamps or a vise to help hold the work when it's practical.

USE EXTRA CAUTION WITH LARGE OR ODD SHAPED WORKPIECES.

- Use extra supports (tables, sawhorses, blocks, etc.) for workpieces large enough to tip.
- Never use another person as a substitute for a table extension, or as an additional support for a workpiece that is longer or wider than the basic miter saw table, or to help feed, support, or pull the workpiece.

OPERATION

- Do not use this saw to cut small pieces. If the workpiece being cut would cause your hand or fingers to be within 8-3/4 inches of the saw blade the workpiece is too small. Keep hands and fingers out of the “no hands zone” area marked on the saws table.
- When cutting odd shaped workpieces, plan your work so it will not bind in the blade and cause possible injury. Molding, for example, must lie flat or be held by a fixture or jig that will not let it move when cut.
- Properly support round material such as dowel rods, or tubing, which have a tendency to roll when cut, causing the blade to “bite”.

WARNING

To avoid injury, follow all applicable safety instructions, when cutting non-ferrous metals:

- Use only saw blades specifically recommended for non-ferrous metal cutting.
- Do not cut metal workpieces that must be hand held. Clamp workpieces securely.
- Cut non-ferrous metals only if you are under the supervision of an experienced person and the dust bag has been removed from the saw.

WHEN SAW IS RUNNING

WARNING

Do not allow familiarity from frequent use of your miter saw to result in a careless mistake. A careless fraction of a second is enough to cause a severe injury. Before cutting, if the saw makes an unfamiliar noise or vibrates, stop immediately. Turn the saw OFF. Unplug the saw. Do not restart until finding and correcting the problem.

BODY AND HAND POSITION (FIG. U)

WARNING



Never place hands near the cutting area. Proper positioning of your body and hands when operating the miter saw will make cutting easier and safer. Keep children away. Keep all visitors at a safe distance from the miter saw. Make sure bystanders are clear of the saw and workpiece. Don't force the saw. It will do the job better and safer at its designed rate.

Starting a cut:

- Place hands at least 8-3/4 in. away from the path of the blade – out of the “no-hands zone” (1). (Fig. U)
- Hold workpiece firmly against the fence to prevent movement toward the blade.
- With the power switch OFF, bring the saw blade down to the workpiece to see the cutting path of the blade.
- Press in lock-off switch in trigger switch handle.
- Squeeze trigger switch to start saw.
- Lower blade into workpiece with a firm downward motion.

Finishing a cut:

- Hold the cutting arm in the down position.
- Release trigger switch and wait for all moving parts to stop before moving your hands and raising the cutting arm.
- If the blade doesn't stop within 10 seconds, unplug the saw and follow the instructions in TROUBLESHOOTING GUIDE section.

Before freeing jammed material:

- Release trigger switch.
- Wait for all moving parts to stop.
- Unplug the miter saw.

Fig. U

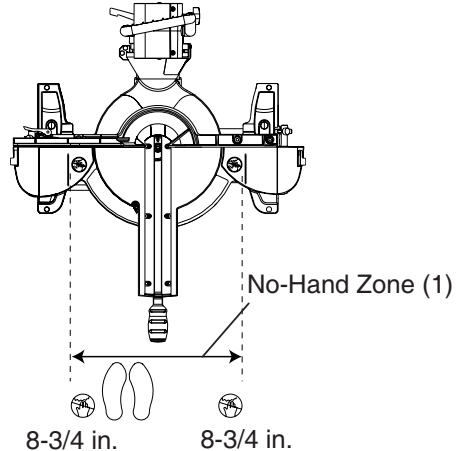

BASIC SAW OPERATIONS

WARNING

For your convenience, your saw has a blade brake. The brake is not a safety device. Never rely on it to replace the proper use of the guard on your saw. If the blade doesn't stop within approximately 10 seconds, wait for the blade to stop, unplug the saw and contact customer service.

TURNING THE SAW ON (FIG. V)

Depress the trigger switch (1) to turn on the miter saw started.

NOTE: Make the ON/OFF switch childproof. Insert a padlock, or chain with padlock, through the holes (2) in the trigger switch, locking the tool's switch, preventing children and other unqualified users from turning the machine on.

The miter saw is equipped with an automatic blade brake. When the trigger switch is released, the electric blade brake will stop the blade within approximately 10 seconds.

Fig. V

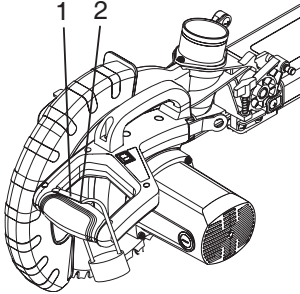

SLIDING FENCE & REMOVE

SLIDING FENCE (FIG. W)

Sliding Fence

⚠ WARNING

The sliding fence must be extended to the left when making bevel cuts. The sliding fences note three bevel angles where the user must adjust the fences to match the degree of the bevel cut. Failure to extend the sliding fence will not allow enough space for the blade to pass through which could result in serious injury. At extreme miter or bevel angles the saw blade may also contact the fence.

1. Unlock the fence cam locking lever (1) by pushing it toward the rear of the machine.
2. Extend the fence (2) by sliding it out to match the degree of the bevel cut. Lock the fence cam locking lever by pushing it IN toward the fence.

NOTE: When transporting the saw, always secure the sliding fence in the collapsed position (toward the saw blade).

Fig. W

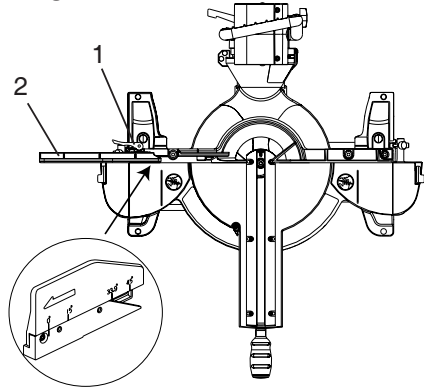

SLIDING CARRIAGE SYSTEM (FIG. X)

⚠ WARNING

To reduce the risk of injury, return carriage to the full rear position after each crosscut operation.

1. For chop cutting operations on small workpieces, slide the cutting head assembly completely toward the rear of the unit and tighten the carriage lock knob (1).
2. To cut wide boards up to 12-1/4 in., the carriage lock knob must be loosened to allow the cutting head to slide freely.

Fig. X

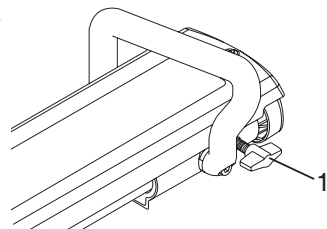

BEFORE LEAVING THE SAW

- Never leave tool running unattended. Turn power OFF. Wait for all moving parts to stop.
- Make workshop childproof. Lock the shop. Disconnect master switches. Store tool away from children and other unqualified users.

⚠ WARNING

To avoid injury from materials being thrown, always unplug the saw to avoid accidental starting, and remove small pieces of material from the table cavity.

MITER CUT (FIG. Y)

1. When a miter cut is required, unlock the miter table by turning the miter handle (1) counterclockwise.
2. While holding the miter handle, lift up on the positive stop locking lever (2).
3. Rotate the miter table to the right or left with the miter handle.
4. When the table is in the desired position, as shown on the miter scale (3), release the positive stop locking lever and tighten the miter handle. The table is now locked at the desired angle. Positive stops are provided at 0°, 15°, 22.5°, 31.6° and 45°.

IMPORTANT: Always tighten the miter table lock handle before performing every cutting operation.

Fig. Y

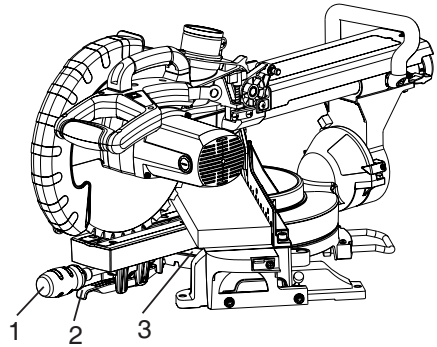

⚠ WARNING

The sliding fence must be extended to the left when making bevel cuts. The sliding fences note three bevel angles where the user must adjust the fences to match the degree of the bevel cut. Failure to extend the sliding fence will not allow enough space for the blade to pass through which could result in serious injury. At extreme miter or bevel angles the saw blade may also contact the fence.

BEVEL CUT (FIG. Z)

1. When a bevel cut is required, loosen the bevel lock handle (1) by turning it clockwise.
2. Tilt the cutting head to the desired angle, as shown on the bevel scale (2).
3. The blade can be positioned at any angle, from a 90° straight cut (0° on the scale) to a 45° left bevel. Tighten the bevel lock handle (1) to lock the cutting head in position. Positive stops are provided at 0°, 33.9° and 45°.

Fig. Z

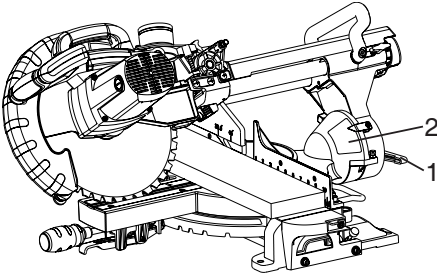

NOTE: The saw comes with a 33.9° crown molding stop.

33.9° BEVEL STOP FOR CROWN MOLDING (FIG. AA)

1. Push the bevel detent stop pin (2) in toward the front of the machine.
2. Loosen the bevel lock handle (1).
3. Rotate the cutting head until the bevel detent pin stops the bevel angle at 33.9° on the bevel scale.
4. Tighten the bevel lock handle before making a cut.

Fig. AA

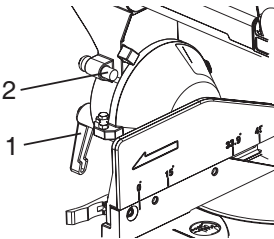

COMPOUND CUT (FIG. BB)

A compound cut is the combination of a miter and a bevel cut simultaneously.

1. Loosen the bevel lock handle (1) and position the cutting head at the desired bevel position. Lock the bevel lock handle.
2. Loosen the miter handle (2). Lift up the positive stop locking lever (3) and position the table at the desired

angle. Release the positive stop locking lever and lock the miter handle.

Fig. BB

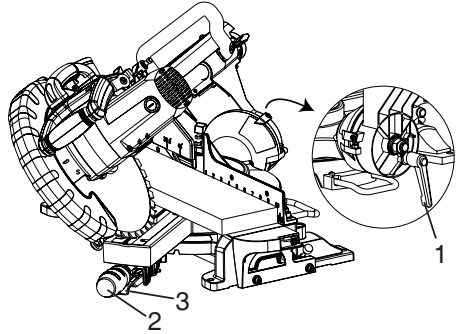

SLIDE CUTTING WIDE BOARDS UP TO 12-1/4 in. WIDE (FIG. CC)

▲ WARNING

To avoid injury:

- Never pull the cutting head assembly and spinning blade toward you during the cut. The blade may try to climb up on the top of the workpiece, causing the cutting assembly and spinning blade to kick back, forcefully. The cutting head assembly should be drawn back completely then pushed forward when sawing.
- Let the blade reach full speed before cutting. This will help reduce the risk of a thrown workpiece.

To Slide Cut Wide Boards (Fig. CC)

1. Unlock the carriage lock handle (1) and allow the cutting head assembly to move freely.
2. Set both the desired bevel angle and/or the miter angle and lock into position.

3. Use a hold down clamp to secure the workpiece.
4. Grasp the switch handle (2) and pull the carriage (3) forward until the center of the saw blade is over the front of the workpiece (4).
5. Engage the trigger to turn the saw on.
6. When the saw reaches full speed, push the switch handle down, slowly, cutting through the leading edge of the workpiece.
7. Slowly move the switch handle toward the fence, completing the cut.
8. Release the trigger and allow the blade to stop spinning before allowing the cutting head to raise.

Fig. CC

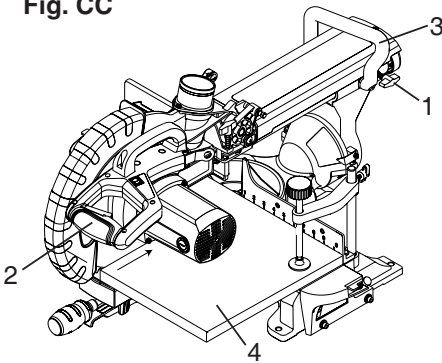

WORKPIECE SUPPORT AND REPETITIVE CUTTING USING THE STOP PLATE (FIG. DD)

Long pieces need extension table support.

1. Loosen the knob (5) then slide the extension table to desired position and tighten the knob.
2. The stop plate is designed for use during repetitive cutting. Only use

one stop plate at a time. Loosen the locking screw (6), rotate the stop plate (7) to vertical position and retighten the locking bolt.

Fig. DD

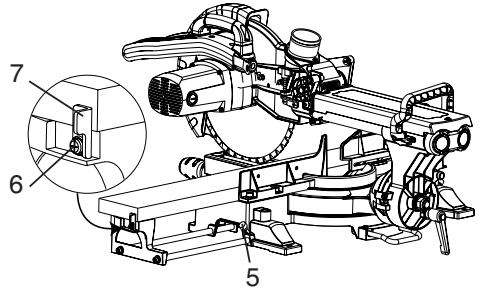

CUTTING BOWED MATERIAL (FIG. EE)

A bowed workpiece must be positioned against the fence and secured with a clamping device before cutting as shown. Do not position workpiece incorrectly or try to cut the workpiece without the support of the fence. This will cause the blade to bind and could result in personal injury.

Fig. EE

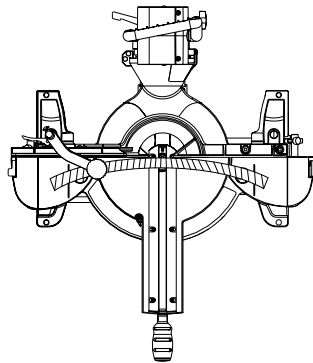

AUXILIARY WOOD FENCE (FIG. FF)

When making multiple or repetitive cuts that result in cut-off pieces of one inch or less, it is possible for the saw blade to catch the cut-off piece and throw it out of the saw or into the blade guard and housing, possibly causing damage or injury. To minimize this, an auxiliary wood fence can be mounted to your saw.

Holes are provided in the saw fence to attach an auxiliary wood fence. This fence is to be constructed of straight wood approximately 3/4 in. thick by 2-1/2 in. high by 18 in. long. Attach the wood fence securely and make a full depth cut to make a blade slot.

Check for interference between the wood fence and the lower blade guard. Adjust if necessary.

NOTE: This auxiliary fence is used only with the saw blade in the 0° bevel position (90° to the table). The auxiliary wood fence must be removed when bevel cutting.

Fig. FF

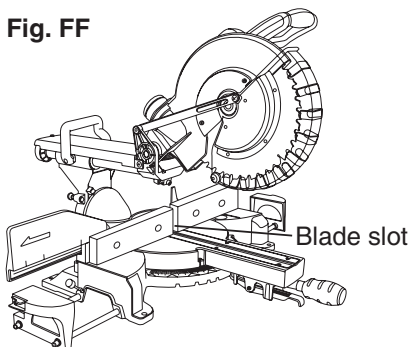

CUTTING BASE MOLDING (FIG. GG)

Base moldings and many other moldings can be cut on a compound miter saw. The setup of the saw depends on molding characteristics and application, as shown. Perform practice cuts on scrap material to achieve best results:

1. Always make sure moldings rest firmly against fence and table. Use hold-down, crown molding vise or C-clamps, whenever possible, and place tape on the area being clamped to avoid marks.
2. Reduce splintering by taping the cut area prior to making the cut. Mark the cut line directly on the tape.
3. Splintering typically happens due to an incorrect blade application and thinness of the material.

Fig. GG

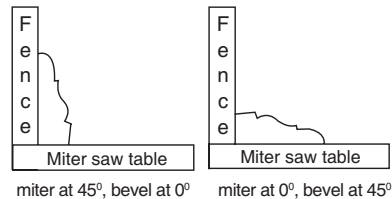

NOTE: Always perform a dry run cut so you can determine if the operation being attempted is possible before power is applied to the saw.

CUTTING CROWN MOLDING (FIG. HH, II)

Your compound miter saw is suited for the difficult task of cutting crown molding. To fit properly, crown molding must be compound-mitered with extreme accuracy. The two surfaces on a piece of crown molding that fit flat against the ceiling and wall are at angles that, **when added together, equal exactly 90°.**

Most crown molding has a top rear angle (the section that fits flat against the ceiling) of 52° and a bottom rear angle (the section that fits flat against the wall) of 38°.

In order to accurately cut crown molding for a 90° inside or outside corner, lay the molding with its broad back surface flat on the saw table.

When setting the bevel and miter angles for compound miters, remember that the settings are interdependent; changing one changes the other, as well.

Fig. HH

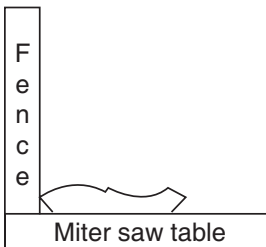

Bevel/Miter Settings

Fig. II

Settings for standard crown molding lying flat on compound miter saw table

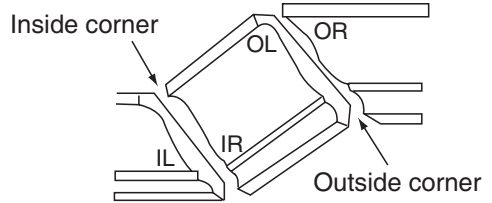

Compound cut crown moldings

NOTE: The chart below references a compound cut for crown molding ONLY WHEN THE ANGLE BETWEEN THE WALLS EQUALS 90°.

Bevel/Miter Settings

KEY	BEVEL SETTING	MITER SETTING	TYPE OF CUT
Inside corner-Left side			
IL	33.9°	31.6° Right	1. Position top of molding against fence. 2. Miter table set at RIGHT 31.6°. 3. LEFT side is finished piece.
Inside corner-Right side			
IR	33.9°	31.6° Left	1. Position bottom of molding against fence. 2. Miter table set at LEFT 31.6°. 3. LEFT side is finished piece.
Outside corner-Left side			
OL	33.9°	31.6° Left	1. Position bottom of molding against fence. 2. Miter table set at LEFT 31.6°. 3. RIGHT side is finished piece.
Outside corner-Right side			
OR	33.9°	31.6° Left	1. Position top of molding against fence. 2. Miter table set at RIGHT 31.6°. 3. RIGHT side is finished piece.

CROWN MOLDING CHART

Compound Miter saw Miter and bevel Angle settings Wall to Crown Molding Angle

Angle Between Walls	52/38° Crown Molding		45/45° Crown Molding	
	Miter Setting	Bevel Setting	Miter Setting	Bevel Setting
67	42.93	41.08	46.89	36.13
68	42.39	40.79	46.35	35.89
69	41.85	40.50	45.81	35.64
70	41.32	40.20	45.28	35.40
71	40.79	39.90	44.75	35.15
72	40.28	39.61	44.22	34.89
73	39.76	39.30	43.70	34.64
74	39.25	39.00	43.18	35.38
75	38.74	38.69	42.66	34.12
76	38.24	38.39	42.15	33.86
77	37.74	38.08	41.64	33.60
78	37.24	37.76	41.13	33.33
79	36.75	37.45	40.62	33.07
80	36.27	37.13	40.12	32.80
81	35.79	36.81	39.62	32.53
82	35.31	36.49	39.13	32.25
83	34.83	36.17	38.63	31.98
84	34.36	35.85	38.14	31.70
85	33.90	35.52	37.66	31.42
86	33.43	35.19	37.17	31.34
87	32.97	34.86	36.69	30.86
88	32.52	34.53	36.21	30.57
89	32.07	34.20	35.74	30.29
90	31.62	33.86	35.26	30.00
91	31.17	33.53	34.79	29.71
92	30.73	33.19	34.33	29.42
93	30.30	32.86	33.86	29.13
94	29.86	32.51	33.40	28.83
95	29.43	32.17	32.94	28.54
96	29.00	31.82	32.48	28.24
97	28.58	31.48	32.02	27.94
98	28.16	31.13	31.58	27.64
99	27.74	30.78	31.13	27.34
100	27.32	30.43	30.68	27.03
101	26.91	30.08	30.24	26.73
102	26.50	29.73	29.80	26.42
103	26.09	29.38	29.36	26.12
104	25.69	29.02	28.92	25.81
105	25.29	28.67	28.48	25.50
106	24.89	28.31	28.05	25.19
107	24.49	27.96	27.62	24.87
108	24.10	27.59	27.19	24.56
109	23.71	27.23	26.77	24.24
110	23.32	26.87	26.34	23.93
111	22.93	26.51	25.92	23.61
112	22.55	26.15	25.50	23.29
113	22.17	25.78	25.08	22.97
114	21.79	25.42	24.66	22.66
115	21.42	25.05	24.25	22.33
116	21.04	24.68	23.84	22.01
117	20.67	24.31	23.43	21.68
118	20.30	23.94	23.02	21.36
119	19.93	23.57	22.61	21.03
120	19.57	23.20	22.21	20.70
121	19.20	22.83	21.80	20.38
122	18.84	22.46	21.40	20.05
123	18.48	22.09	21.00	19.72

Angle Between Walls	52/38° Crown Molding		45/45° Crown Molding	
	Miter Setting	Bevel Setting	Miter Setting	Bevel Setting
124	18.13	21.71	20.61	19.39
125	17.77	21.34	20.21	19.06
126	17.42	20.96	19.81	18.72
127	17.06	20.59	19.42	18.39
128	16.71	20.21	19.03	18.06
129	16.37	19.83	18.64	17.72
130	16.02	19.45	18.25	17.39
131	15.67	19.07	17.86	17.05
132	15.33	18.69	17.48	16.71
133	14.99	18.31	17.09	16.38
134	14.66	17.93	16.71	16.04
135	14.30	17.55	16.32	15.70
136	13.97	17.17	15.94	15.36
137	13.63	16.79	15.56	15.02
138	13.30	16.40	15.19	14.62
139	12.96	16.02	14.81	14.34
140	12.63	15.64	14.43	14.00
141	12.30	15.25	14.06	13.65
142	11.97	14.87	13.68	13.31
143	11.64	14.48	13.31	12.97
144	11.31	14.09	12.94	12.62
145	10.99	13.71	12.57	12.29
146	10.66	13.32	12.20	11.93
147	10.34	12.93	11.83	11.59
148	10.01	12.54	11.46	11.24
149	9.69	12.16	11.09	10.89
150	9.37	11.77	10.73	10.55
151	9.05	11.38	10.36	10.20
152	8.73	10.99	10.00	9.85
153	8.41	10.60	9.63	9.50
154	8.09	10.21	9.27	9.15
155	7.77	9.82	8.91	8.80
156	7.46	9.43	8.55	8.45
157	7.14	9.04	8.19	8.10
158	6.82	8.65	7.83	7.75
159	6.51	8.26	7.47	7.40
160	6.20	7.86	7.11	7.05
161	5.88	7.47	6.75	6.70
162	5.57	7.08	6.39	6.35
163	5.26	6.69	6.03	6.00
164	4.95	6.30	5.68	5.65
165	4.63	5.90	5.32	5.30
166	4.32	5.51	4.96	4.94
167	4.01	5.12	4.61	4.59
168	3.70	4.72	4.25	4.24
169	3.39	4.33	3.90	3.89
170	3.08	3.94	3.54	3.53
171	2.77	3.54	3.19	3.10
172	2.47	3.15	2.83	2.83
173	2.15	2.75	2.48	2.47
174	1.85	2.36	2.12	2.12
175	1.54	1.97	1.77	1.77
176	1.23	1.58	1.41	1.41
177	0.92	1.18	1.06	1.06
178	0.62	0.79	0.71	0.71
179	0.31	0.39	0.35	0.35

MAINTENANCE

MAINTENANCE

⚠ WARNING

Never put lubricants on the blade while it is spinning.

⚠ WARNING

- To avoid fire or toxic reaction, never use gasoline, naphtha acetone, lacquer thinner or similar highly volatile solvents to clean the miter saw.
- To avoid injury from unexpected starting or electrical shock, unplug the power cord before working on the saw.
- For your safety, this saw is double insulated. To avoid electrical shock, fire or injury, use only parts identical to those identified in the parts list. Reassemble exactly as the original assembly to avoid electrical shock.

REPLACING CARBON BRUSHES (FIG. JJ)

Replace both carbon brushes when either has less than 1/4 in. length of carbon remaining, or if the spring or wire is damaged or burned. To inspect or replace brushes, first unplug the saw. Then remove the black plastic cap (1) on the side of the motor (2). Carefully remove the spring-loaded cap. Then pull out the brush and replace. Replace for the other side. To reassemble, reverse the procedure.

The ears on the metal end of the assembly go in the same hole the carbon part fits into. Tighten the cap snugly, but do not overtighten.

NOTE: When reinstalling the same brushes, put them back in the way they came out. This will avoid a break-in period that reduces motor performance and increases wear.

Fig. JJ

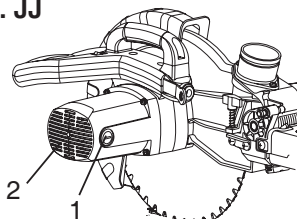

LOWER BLADE GUARD

Do not use the saw without the lower blade guard. The lower blade guard is attached to the saw for your protection. Should the lower guard become damaged, do not use the saw until the damaged guard has been replaced. Check regularly to make sure the lower guard is working properly. Clean the lower guard of any dust or buildup with a damp cloth.

⚠ WARNING

- Do not use solvents on the guard. They could make the plastic “cloudy” and brittle.
- When cleaning the lower guard, unplug the saw from the power source receptacle to avoid unexpected start-up.

MAINTENANCE

SAWDUST

Periodically, sawdust will accumulate under the worktable and base. This could cause difficulty in the movement of the worktable when setting up a miter cut. Frequently blow out or vacuum up the sawdust.

! WARNING

If blowing sawdust, wear proper eye protection to keep debris from blowing into eyes.

LUBRICATION (FIG. KK)

All the motor bearings in this tool are lubricated with a sufficient amount of high-grade lubricant for the life of the unit under normal operating conditions; therefore, no further lubrication is required.

Lubricate the following as necessary:

Chop pivot: Apply light machine oil to points indicated in illustration.

Central pivot of plastic guard: Use light household oil (sewing machine oil) on metal-to-metal or metal-to-plastic guard contact areas as required for smooth, quiet operation. Avoid excessive oil, to which sawdust will cling.

Link: (which actuates the lower guard movement) may be oiled at the rear pivot, greased at ball bearing contact, and oiled where the link actuates the acetyl roller of the lower guard, if the down chop motion is hard to start.

Fig. KK

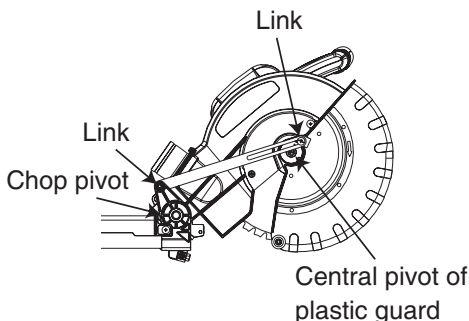

TROUBLESHOOTING GUIDE

WARNING

To avoid injury from accidental starting, always turn switch OFF and unplug the tool before moving, replacing the blade or making adjustments.

TROUBLESHOOTING GUIDE - MOTOR

PROBLEM	PROBLEM CAUSE	SUGGESTED CORRECTIVE ACTION
Brake does not stop blade within 10 seconds.	<ol style="list-style-type: none"> 1. Motor brushes not sealed or lightly sticking. 2. Motor brake overheated from use of defective or wrong size blade or rapid ON/OFF cycling. 3. Arbor bolt loose. 4. Brushes cracked, damaged, etc. 5. Other. 	<ol style="list-style-type: none"> 1. Inspect/clean/replace brushes. See MAINTENANCE section. 2. Use a recommended blade. Let cool down. See REMOVING OR INSTALLING THE BLADE section. 3. Retighten. See REMOVING OR INSTALLING THE BLADE section. 4. Replace brushes. 5. Contact Sears Service Center.
Motor does not start	<ol style="list-style-type: none"> 1. Limit switch failure 2. Brush worn. 3. Fuse blown or circuit breaker tripped on home panel. 	<ol style="list-style-type: none"> 1. Replace limit switch. 2. Replace brushes. See MAINTENANCE section. 3. Verify there is electrical power at the outlet.
Brush spark when switch released.	<ol style="list-style-type: none"> 1. Brush worn. 2. Other. 	<ol style="list-style-type: none"> 1. Replace Brushes. See MAINTENANCE section. 2. Contact Sears Service Center.

TROUBLESHOOTING GUIDE

TROUBLESHOOTING GUIDE - SAW OPERATION

PROBLEM	PROBLEM CAUSE	SUGGESTED CORRECTIVE ACTION
Blade hits table.	1. Misalignment.	1. See ADJUSTMENT - Setting Cutting Depth section.
Angle of cut not accurate. Can not adjust miter.	1. Miter table unlocked. 2. Sawdust under table.	1. See OPERATION - Miter Angle Adjustment section. 2. Vacuum or blow out dust. WEAR EYE PROTECTION.
Cutting arm wobbles.	1. Loose pivot points.	1. Contact Sears Service Center.
Cutting arm will not fully raise, or blade guard won't fully close.	1. Pivot spring not replaced properly after service. 2. Sawdust build-up.	1. Contact Sears Service Center. 2. Clean and lubricate moving parts.
Blade binds, jams, burns wood.	1. Improper operation. 2. Dull or warped blade. 3. Improper blade size. 4. Wood is moving during cut.	1. See BASIC SAW OPERATION section. 2. Replace or sharpen blade. 3. Replace with 12 in. diameter blade. 4. Use hold down clamp to secure workpiece to table.
Saw vibrates or shakes.	1. Saw blade not round / damaged / loose. 2. Arbor bolt loose.	1. Replace blade. 2. Tighten arbor bolt.

PARTS LIST

12 in. COMPOUND MITER SAW

MODEL NO. 137.212390



WARNING

When servicing use only CRAFTSMAN replacement parts. Use of any other parts may create a HAZARD or cause product damage. Any attempt to repair or replace electrical parts on this Miter Saw may create a HAZARD unless repair is done by a qualified service technician. Repair service is available at your nearest Sears Service Center.

PARTS LIST FOR SAW SCHEMATIC A

I.D.	Description	Size	QTY	I.D.	Description	Size	QTY
083Z	CORD CLAMP		1	262V	ANCHOR PLATE	# 06	1
091S	COMPRESSION SPRING		1	26LU	WARNING LABEL		1
0CKS	SPRING WIRE		1	26P7	SHAFT-PIVOT		1
0CQH	HOLD DOWN CLAMP ASS'Y		1	27AE	COLLAR		1
0DHT	SPRING GUARD		1	290M	CAUTION LABEL		1
0DTZ	ARBOR COLLAR		2	2C1G	SHAFT-PIVOT		1
0DVJ	BLADE WRENCH		1	2CGT	SLOTTED SET SCREW		4
0F1H	COLLAR		1	2D92	CONTROLLER ASS'Y		1
0J4D	FLAT WASHER	φ5*10-1	2	2DX9	SEGMENT HANDLE		1
0J4E	FLAT WASHER	φ6*13-1	2	2E63	ROCKER SWITCH		1
0J7G	FLAT WASHER	3/8*29/32-1/8	1	2EXC	LOCATION PIN		1
0JBO	WAVE WASHER	WW-8	2	2F39	CLEVIS PIN		1
0JE7	C-RING		1	2F8Y	DUST BAG ASS'Y		1
0JMN	O-RING		1	2F9N	STICKER		1
0JMP	O-RING		1	2GYC	SHAFT SLEEVE		1
0JXB	HEX. SOC. SET SCREW	M6*1.0-16	1	2K96	WARNING LABEL		1
0JZF	HEX. SOC. SET SCREW	M6*1.0-10	2	2MGR	POWER CABLE		1
0JZN	ARBOR BOLT	M8*1.25-20	1	2MN9	LASER PLUNGER HOUSING		1
0K2V	HEX. SOC. HD.CAP SCREW	M5*0.8-30	4	2PWU	MOTOR		1
0K5D	CR. RE. COUNT HD. SCREW	M6*1.0-20	1	2PY1	ARM	# AW	1
0K6Y	CR. RE. TRUSS HD. SCREW	M4*0.7-10	2	2PYE	DUST COLLECTOR		1
0K74	CR. RE. TRUSS HD. SCREW	M6*1.0-8	1	2PYG	CUTTER SHAFT GUARD	# AW	1
0K7X	CR. RE. TRUSS HD. ROUND NECK SCREW	M6*1.0-10	2	2PYJ	SHAFT-PIVOT		1
0K7Z	CR. RE. TRUSS HD. ROUND NECK SCREW	M6*1.0-14	2	2PYK	LEVER		1
0KA9	CR. RE. PAN HD. TAPPING SCREW	M3*24-10	1	2PYL	MOTOR HANDLE (UP)		1
0KB7	CR. RE. PAN HD. TAPPING SCREW	M4*18-16	2	2PYM	MOTOR HANDLE (DOWN)		1
0KBD	CR. RE. PAN HD. TAPPING SCREW	M4*18-25	4	2PYN	CABLE SHIELD		1
0KC6	CR. RE. TRUSS HD. TAPPING SCREW	M4*16-12	1	2PYP	NEEDLE POINTER	# 23	1
0KD6	CR. RE. PAN HD. SCREW	M4*0.7-8	1	2Q19	LEAD WIRE ASS'Y		1
0KDK	CR. RE. PAN HD. SCREW	M5*0.8-16	4	2Q1F	LEAD WIRE ASS'Y		1
0KDM	CR. RE. PAN HD. SCREW	M5*0.8-20	1	2Q2U	TORSION SPRING		1
0KDR	CR. RE. PAN HD. SCREW	M5*0.8-10	1	2Q41	PC-GUARD ASS'Y		1
0KEO	CR. RE. PAN HD. SCREW	M6*1.0-40	2	2QBQ	CLAMP BOLT		1
0KL1	CR. RE. PAN HD. ROUND NECK SCREW	M6*1.0-12	1	2QU7	PLUNGER HOUSING ASS'Y		1
0KMS	HEX. NUT	M6*1.0 T=5	2	2QVY	SWIVEL SUPPORT ASS'Y		1
0KR1	LOCK NUT	M16*2.0 T=16	1	2R2G	TRADE-MARK LABEL		1
0KTQ	CABLE CLAMP		1	2R2M	LABEL		1
0KUW	TERMINAL		2	2R2N	TRADE-MARK LABEL		1
0LTQ	TRIGGER SWITCH		1	2R2Q	CAUTION LABEL		1
0S1S	COLLAR		1	2RAS	FLAT WASHER	Φ16*38-3	2
0XQ8	CR. RE. PAN HD. TAPPING SCREW	M6*1.0-20	2	2RAU	COMPRESSION SPRING		1
23LN	KNOB-HANDLE		1	2RAV	CLAMP BOLT		1
23NX	GUARD-CORD		1	2RCW	BLADE		1

PARTS LIST FOR SAW SCHEMATIC B

I.D.	Description	Size	QTY
0DTH	CENTER BOLT		1
0H9A	REAR EXTENTION STAY		1
0J6A	FLAT WASHER	φ8*16-2.5	1
0J74	FLAT WASHER	1/4*5/8-3/32	6
0JAZ	WAVE WASHER	WW-6	2
0JPF	HEX. HD. BOLT	M6*1.0-25	3
0JXB	HEX. SOC. SET SCREW	M6*1.0-16	1
0JXG	HEX. SOC. SET SCREW	M8*1.25-16	1
0K2B	HEX. SOC. HD. CAP SCREW	M6*1.0-16	6
0K2L	HEX. SOC. HD. CAP SCREW	M8*1.25-30	3
0K74	CR. RE. TRUSS HD. SCREW	M6*1.0-8	2
0K7L	CR. RE. ROUND WASHER HD. SCREW	M6*1.0-16	2
0KAE	CR. RE. PAN HD. TAPPING SCREW	M5*0.8-10	1
0KD6	CR. RE. PAN HD. SCREW	M4*0.7-8	7
0KDS	CR. RE. PAN HD. SCREW	M5*0.8-40	1
0KDU	CR. RE. PAN HD. SCREW	M6*1.0-12	2
0KDV	CR. RE. PAN HD. SCREW	M6*1.0-16	4
0KMS	HEX. NUT	M6*1.0 T=5	3
0KQW	LOCK NUT	M5*0.8 T=5	1
0KQX	NUT	M6*1.0 T=6	2
0KR4	LOCK NUT	M8*1.25 T=8	1
2258	SPECIAL BOLT		1
2754	WARNING LABEL		1
20S3	LOCKING HANDLE ASS'Y		1
20X5	ASSIST-FENCE	# AW	1
21EW	CR. RE. PAN HD. TAPPING SCREW	M5*12-35	1
25TD	MITER BAR		4
25TE	STOP BLOCK (LEFT)	# 23	1
25TF	STOP BLOCK (RIGHT)	# 23	1
27BU	TABLE INSERT		1
27BV	TABLE INSERT		1
2C8U	KNOB		2
2CD2	COMPRESSION SPRING		1
2DWL	PLUNGER HANDLE		1
2DWP	NEEDLE POINTER	# 23	1
2F76	FENCE	# AW	1
2K8Q	WARNING LABEL		1
2LSZ	WISE ASS'Y		1
2PY0	BASE	# AW	1
2PY2	TABLE	# AW	1
2PY7	EXTENSION WING (LEFT)	# AW	1
2PY8	EXTENSION WING (RIGHT)	# AW	1
2PYB	SLIDE-BAR BLADE GUARD		1
2PYD	SEGMENT HANDLE (REAR)		1
2PYH	SET PLATE		1
2PYQ	SLIDE PLATE		3
2PYR	SUPPORT		1
2QT8	CR. RE. TRUSS HD. ROUND NECK SCREW	M6*1.0-17	2
2QXE	INSTRUCTION MANUAL		1
2QZX	SCALE		1
2QZZ	SCALE		1
2R2R	TRADE-MARK LABEL		1
2R7W	LOCKING HANDLE ASS'Y		1

PARTS LIST FOR MOTOR

I.D.	Description	Size	QTY
0JCF	SPRING PIN	φ4-30	1
0JX2	HEX. SOC SET SCREW	M5*0.8-6	2
0K44	CR. RE. PAN HD. SCREW & WASHER	M5*0.8-12	3
0KCP	CR. RE. PAN HEAD TAPPING & WASHER SCREW	M5*12-60	2
0KLA	PLASTIC SCREW	M5*0.8-6	2
0Q9K	FLOW GUIDE		1
0QGR	COMPRESSION SPRING		1
0QMK	RUBBER CAP		1
0QMY	PROTECTOR WIRE		1
0QQS	BRUSH HOLDER ASS'Y		2
0QQT	BRUSH ASS'Y		2
0QR0	BRUSH COVER		2
0QR2	BEARING BUSHING		1
21AX	CLEVIS PIN		1
23Z3	GEAR BOX	# AW	1
23Z4	MOTOR HOUSING		1
240R	ARMATURE ASS'Y		1
27DB	CUTTER SHAFT ASS'Y		1
2B79	CR. RE. PAN HD. SCREW & WASHER	M5*0.8-35	4
2PXT	FIELD ASS'Y		1
2QOP	LEAD WIRE ASS'Y		1

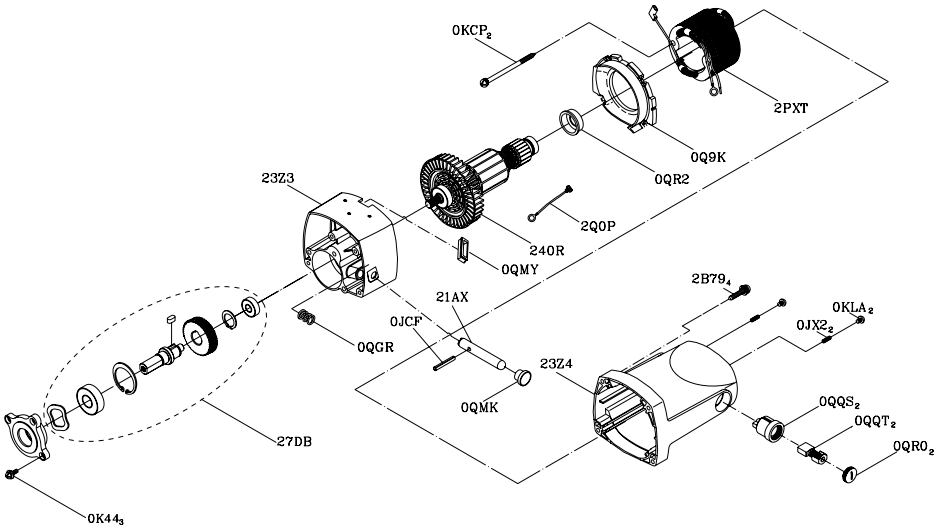

NOTE

Get it fixed, at your home or ours!

Your Home

For expert troubleshooting and home solutions advice:

manage  home

www.managemyhome.com

For repair – **in your home** – of **all** major brand appliances, lawn and garden equipment, or heating and cooling systems, **no matter who made it, no matter who sold it!**

For the replacement parts, accessories and owner's manuals that you need to do-it-yourself.

For Sears professional installation of home appliances and items like garage door openers and water heaters.

1-800-4-MY-HOME® (1-800-469-4663)

Call anytime, day or night (U.S.A. and Canada)

www.sears.com www.sears.ca

Our Home

For repair of carry-in items like vacuums, lawn equipment, and electronics, call anytime for the location of your nearest

Sears Parts & Repair Service Center

1-800-488-1222 (U.S.A.)

www.sears.com

1-800-469-4663 (Canada)

www.sears.ca

To purchase a protection agreement on a product serviced by Sears:

1-800-827-6655 (U.S.A.)

1-800-361-6665 (Canada)

Para pedir servicio de reparación a domicilio, y para ordenar piezas:

1-888-SU-HOGAR®

(1-888-784-6427)

Au Canada pour service en français:

1-800-LE-FOYER^{MC}

(1-800-533-6937)

www.sears.ca



© Registered Trademark / TM Trademark / SM Service Mark of Sears Brands, LLC

© Marca Registrada / TM Marca de Fábrica / SM Marca de Servicio de Sears Brands, LLC

^{MC} Marque de commerce / ^{MD} Marque déposée de Sears Brands, LLC

© Sears Brands, LLC