

Operator's Manual

CRAFTSMAN[®]

2.25 Ton Capacity Trolley Jack

Model 50140

CRAFTSMAN[®]

FOR AFTER SALE PARTS AND SERVICE:

Call 8 AM - 5 PM PST., Monday - Friday
1-888-448-6746

PARA VENTA DE PARTES Y SERVICIO:

Llame 8 AM - 5 PM Tiempo Pacifico., Lunes - Viernes
1-888-448-6746



WARNING : Before using this appliance, read this Operator's Manual and follow all its Safety Rules and Operating Instructions.

- Safety
- Operation
- Maintenance

Sears, Roebuck and Co., Hoffman Estates, IL 60179 U.S.A.
www.sears.com

Printed in China

DESCRIPTION

Craftsman model 50140 Jack Stands: rugged ratchet design for fast, easy secure adjustment and a wide stance for added stability. Baked enamel finish help resist rust and corrosion. Fully adjustable from 10-5/8 inches to 16-1/2 inches

Specifications

Compact design allows use in confined spaces
 Maximum load capacity.....2.25 tons (4500 lbs.)
 Lift range.....10-5/8 to 16-1/2 inches
 Size (LxWxH).....7.09"x6.3"x10.63"
 Weight w/handle.....11.5 lbs.

SAFETY INSTRUCTIONS

IMPORTANT!

Study, Understand and follow all instructions failure to heed this warning may result in personal injury and/or property damage.

WARNING!

Read-Study, understand all warning and operating instructions prior to use. **DO NOT OVERLOAD BEYOND RATED CAPACITY** Always use jack stands on level, solid ground, Never use on slope, inclined, angle or soft surface. Always use stands in pairs, on the same axel, and at the same height. Stands are not to be used to simultaneously support both ends or one side of vehicle. Failure to heed these warnings may result in damage to jack and/or failure resulting in personal injury or property damage. Inspect before each use. Support the vehicle only on areas specified by the vehicle manufacturer. Make sure the load and stand are stable before getting under the vehicle. Center load on saddle. Never use any other additional Support. Some vehicles require an adapter to properly engage the fram for lifting. Use vehicle manufacturers instructions on proper lifting. No alterations shall be made to this product. Only attachments and/or adapters supplied by the manufacturer shall be used.

OPERATION

1. Be sure to insert the fixed pin into hole in the bottom of ratchet to prevent ratchet from detaching from the frame.
2. Put the jack stands on hard level ground
3. Adjust height by pulling up on ratchet.
4. Place load on the center of saddle for safety it is strongly recommended that lifting means not be removed while jack stands are supporting the vehicle.
5. Secure ratchet by turning stopper to hold load. Make sure stopper has been securely inserted. Insert double locking pin.
6. Release stopper and remove double locking pin and let ratchet glide down to the lowest position when storing the jack stand.
7. If the operator is not fluent in English, the product and safety instructions shall be read to and discussed with the operator in the operator's native language by the purchaser/owner or his designee, making sure that the operator comprehends their contents.
8. Inspect before each use **DO NOT USE IF BENT BROKEN OR CRACKED COMPONENT ARE NOTED.** prevent corrosion. Clean as needed and wipe with an oily cloth and keep in dry area when not in use.

WARRANTY

CRAFTSMAN ONE YEAR FULL WARRANTY

If this Craftsman product fails due to a defect in material or workmanship within one year from the date of purchase, return it to any Sears store or other Craftsman outlet in the United States for free replacement. This warranty applies for only 90 days from the date of purchase if this product is ever used for commercial or rental purposes.

This warranty gives you specific legal rights, and you may also have other rights which vary from state to state. Sears, Roebuck and Co., Hoffman Estates, IL 60179

CAUTION

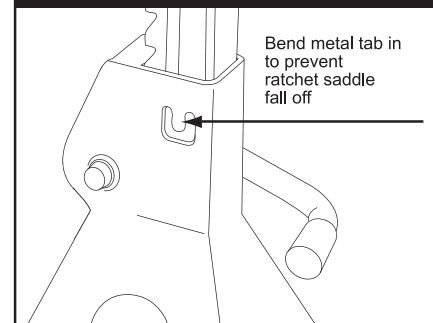

Visual inspection shall be performed before each use of the stand by checking abnormal condition, such as cracked welds, leaks and damaged, loose, or missing parts if stand is believed to have been subjected to abnormal load or shock inspection shall be made by authorized repair facility. Equipment that appears damage or worn or operates abnormally shall be removed from service until repair. Repair should be made by authorized repair facility. Annual inspection of the stand is recommended and should be made by the manufacturer's or supplier's authorized repair facility to ensure that you stand is optimum conditions and that the stand has correct decals and safety labels specified by the manufacturer.

PICTURE 2

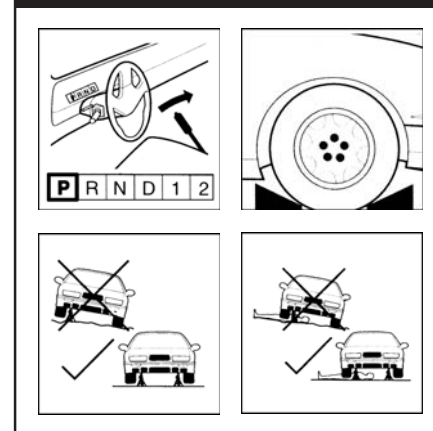

ASSEMBLY

Assembly

Handle Assembly

- Attach handle (P23) and grip (P24) by pushing both pieces together.
- Insert the assembled handle into the socket by aligning the stem on the handle end with the slot in the socket and turn to secure. (Pic. 1)

PICTURE 1

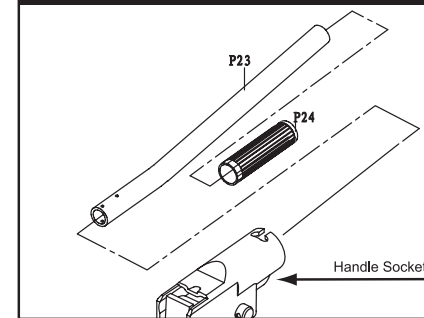

FEATURES & OPERATION

Operation

Raising the Jack

- Using the handle to close the air release valve by turning the handle clockwise as far as it will go. **DO NOT OVER TIGHTEN!**
- Block the vehicle's wheels for lifting stability.
- Refer to the vehicle manufacturer owner's manual to locate approved lifting points on the vehicle. Position the jack so that the saddle is centered and will contact the load lifting point firmly.
- Pump jack handle until saddle nears contact with the vehicle. Check to see that the saddle is centered and will contact the load lifting point firmly.
- Continue to pump the jack handle to lift the vehicle to the desired height. After lifting, support the load with appropriately rated vehicle support stands before working on the vehicle.

Lowering the Jack

- Carefully open the air release valve by slowly turning the valve counterclockwise.

How it Works

With Release Valve Closed

- An upward stroke of the jack handle draws oil from the reservoir tank into the plunger cavity. Hydraulic pressure holds the valve closed, which keeps the oil in the plunger cavity.
- A downward stroke of the jack handle releases oil into the cylinder, which forces the ram out. This raises the saddle.
- When the ram reaches maximum extension, oil is bypassed back into the reservoir to prevent an over extended ram stroke and possible damage to the jack.
- Opening the release valve allows oil to flow back into the reservoir. This releases hydraulic pressure on the ram, which results in lowering the saddle.

MAINTENANCE

To Add Oil:

- Position the jack on level ground and lower the saddle.
- Use a flat blade screwdriver to pop off the inspection plate.
- Remove the oil plug.
- Fill the oil case until oil level is just beneath the lower rim of oil fill hole. Replace oil plug.
- Perform the Air Purge Procedure described below.

To Replace Oil:

- Fully open release valve by turning handle counterclockwise as far as it will go.
- Turn the jack over so that old oil will drain from the oil fill hole.
- Refill through oil fill hole. Keep dirt and other material clear when pouring. Fill to just beneath lower rim of hole. Replace oil plug.
- Perform Air Purge Procedure described below.

Lubrication

- Add lubricating oil (WD-40) to all moving parts when needed.
- For light duty use lubricate every six months.
- For heavy and constant use lubrication recommended every month.

Rust Prevention:

- Check ram and pump plunger on the Power Unit Assembly every two months (or sooner, based on usage) for any signs of rust or corrosion. Lift the jack as high as it goes and look under and behind the lifting arm. If signs of rust are visible clean as needed and wipe down with an oily cloth or WD-40.
- When storing the jack, always have the saddle and pump plunger in the down position.

ALWAYS USE A GOOD GRADE HYDRAULIC JACK OIL. DO NOT USE HYDRAULIC BRAKE FLUID, ALCOHOL, GLYCERINE, DETERGENT, MOTOR OIL OR DIRTY OIL. USE OF AN UN-RECOMMENDED FLUID CAN CAUSE DAMAGE TO YOUR JACK.

Air Purge Procedure

During shipment or after oil refill, air may get into the hydraulic system causing poor lifting performance. Then system air purge is required as follows:

1. Turn the release valve fully counterclockwise to fully open the release valve.
2. Pump handle rapidly several times.
3. Turn the release valve clockwise to close the release valve.
4. Pump handle until the lift arm reaches maximum height and continue to pump several times to remove trapped air in the ram.
5. Turn the release valve fully counterclockwise to lower lift arm to lowest position. Use force on saddle if necessary.
6. Turn the release valve clockwise to closed position and check for proper pump action. It may be necessary to perform the above steps more than once to assure air is evacuated totally.

EXPLODED VIEW AND PARTS LIST

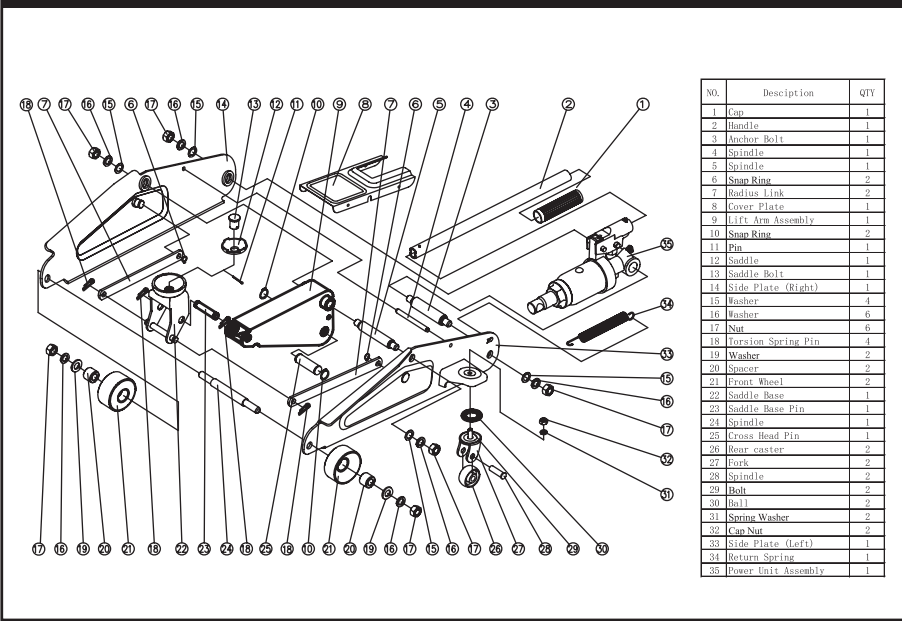

| No. | Description | QTY |
|-----|---------------------|-----|
| 1 | Cap | 1 |
| 2 | Handle | 1 |
| 3 | Anchor Bolt | 1 |
| 4 | Spindle | 1 |
| 5 | Spindle | 1 |
| 6 | Snap Ring | 2 |
| 7 | Radius Link | 2 |
| 8 | Cover Plate | 1 |
| 9 | LIFT Arm Assembly | 1 |
| 10 | Snap Ring | 2 |
| 11 | Pin | 1 |
| 12 | Saddle | 1 |
| 13 | Saddle Bolt | 1 |
| 14 | Side Plate (Right) | 1 |
| 15 | Washer | 4 |
| 16 | Washer | 6 |
| 17 | Nut | 6 |
| 18 | Torsion Spring Pin | 4 |
| 19 | Washer | 2 |
| 20 | Spacer | 2 |
| 21 | Front Wheel | 2 |
| 22 | Saddle Base | 1 |
| 23 | Saddle Base Pin | 1 |
| 24 | Spindle | 1 |
| 25 | Cross Head Pin | 1 |
| 26 | Rear Caster | 2 |
| 27 | Fork | 2 |
| 28 | Spindle | 2 |
| 29 | Bolt | 2 |
| 30 | Bar | 2 |
| 31 | Spring Washer | 2 |
| 32 | Cap Nut | 2 |
| 33 | Side Plate (Left) | 1 |
| 34 | Return Spring | 1 |
| 35 | Power Unit Assembly | 1 |

TROUBLESHOOTING

| JACK WILL NOT LIFT LOAD | JACK WILL NOT HOLD LOAD | JACK WILL NOT LOWER | POOR JACK LIFTING | CAUSES AND SOLUTIONS |
|-------------------------|-------------------------|---------------------|-------------------|---|
| X | | | | RELEASE VALVE IS NOT COMPLETELY CLOSED. TURN CLOCKWISE. |
| X | | | X | AIR IS IN HYDRAULICS. PURGE AIR FROM SYSTEM. |
| X | X | | X | LOW OIL LEVEL. ADD OIL AS REQUIRE. |
| | | X | | OIL RESERVOIR IS OVERFILLED: DRAIN EXCESSIVE OIL. LUBRICATE MOVING PARTS. |
| X | X | | X | POWER UNIT MALFUNCTIONING. REPLACE THE POWER UNIT. |

FOR AFTER SALE PARTS AND SERVICE:
 Call 8 AM - 5 PM PST., Monday - Friday
 1-888-448-6746

Operator's Manual



2.25 Ton Jack Stands

Model 50140



WARNING : Before using this appliance, read this Operator's Manual and follow all its Safety Rules and Operating Instructions.

- Safety
- Operation

Sears, Roebuck and Co., Hoffman Estates, IL 60179 U.S.A.
www.sears.com