

# Operator's Manual

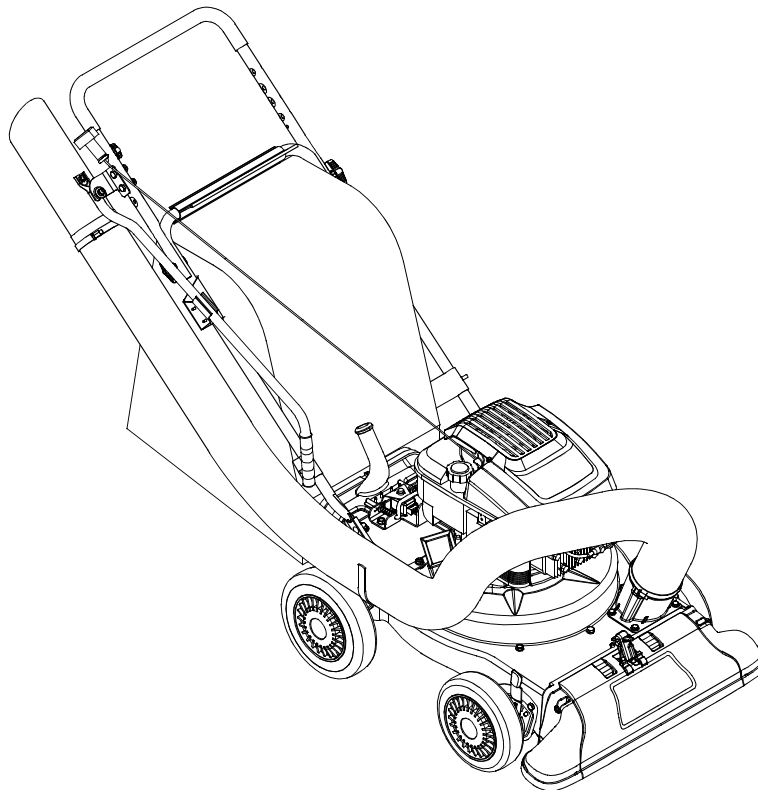

6.0 Horse Power  
**YARD VACUUM**  
Model No. 247.770550



**CAUTION:** Before using this product, read this manual and follow all Safety Rules and Operating Instructions.

- Safety
- Assembly
- Operation
- Maintenance
- Parts
- Español

**Sears, Roebuck and Co., Hoffman Estates, IL 60179, U.S.A.**

Visit our Sears website: [www.sears.com/craftsman](http://www.sears.com/craftsman)

Printed in U.S.A.

FORM NO. 769-00407A

(10/02)

## TABLE OF CONTENTS

Content	Page	Content	Page
Warranty	2	Service and Adjustments	14
Safety	3	Storage	16
Assembly	5	Troubleshooting	17
Operation	8	Parts List	18
Maintenance	12		

## WARRANTY

### Limited Warranty on Craftsman Yard Vacuum

For one (1) year from the date of purchase, if this Craftsman Equipment is maintained, lubricated, and tuned up according to the instructions to the operator's manual, Sears will repair or replace free of charge any parts found to be defective in material or workmanship. Warranty service is available free of charge by returning Craftsman equipment to your nearest Sears Service Center. In-home warranty service is available but a trip charge will apply. This Warranty applies only while this product is in the United States.

**This Warranty does not cover:**

- Expendable items which become worn during normal use, such as spark plugs, air cleaners, belts, and oil filters.
- Tire replacement or repair caused by punctures from outside objects, such as nails, thorns, stumps, or glass.
- Repairs necessary because of operator abuse, including but not limited to, damage caused by objects, such as stones or metal debris, oversized stock, impacting objects that bend the frame or crankshaft, or over-speeding the engine.
- Repairs necessary because of operator negligence, including but not limited to, electrical and mechanical damage caused by improper storage, failure to use the proper grade and amount of engine oil, or failure to maintain the equipment according to the instructions contained in the operator's manual.
- Engine (fuel system) cleaning or repairs caused by fuel determine to be contaminated or oxidized (stale). In general, fuel should be used **within 30 days** of its purchase date.
- Equipment used for commercial or rental purposes.

TO LOCATE THE NEAREST SEARS SERVICE CENTER OR TO SCHEDULE SERVICE, SIMPLY CONTACT SEARS AT 1-800-4-MY-HOME.

This warranty gives you specific legal rights and you may also have other rights, which vary from state to state.

PRODUCT SPECIFICATION		
Horsepower:	6.0 Horse Power	Model Number..... <b>247.770550</b> .....
Engine Oil Type	SAE 30	Serial Number.....
Engine Oil Capacity	20 Ounces	Date of Purchase.....
Fuel Capacity:	1 1/2 Quarts	Record both serial number and date of purchase and keep in a safe place for future reference.
Spark Plug	Champion RJ-19LM	
Spark Plug Gap	.030"	

## SAFETY



**WARNING:** This symbol points out important safety instructions which, if not followed, could endanger the personal safety and/or property of yourself and others. Read and follow all instructions in this manual before attempting to operate this machine. Failure to comply with these instructions may result in personal injury. When you see this symbol - **heed its warning.**

**WARNING:** Engine Exhaust, some of its constituents, and certain vehicle components contain or emit chemicals known to State of California to cause cancer and birth defects or other reproductive harm.

**DANGER:** This machine was built to be operated according to the rules for safe operation in this manual. As with any type of power equipment, carelessness or error on the part of the operator can result in serious injury. This machine is capable of amputating hands and feet and throwing objects. Failure to observe the following safety instructions could result in serious injury or death.

### TRAINING

1. Read, understand, and follow all instructions on the machine and in the manual(s) before attempting to assemble and operate. Keep this manual in a safe place for future and regular reference and for ordering replacement parts.
  2. Be familiar with all controls and their proper operation. Know how to stop the machine and disengage them quickly.
  3. Never allow children under 16 years old to operate this machine. Children 16 years old and over should read and understand the operation instructions and safety rules in this manual and should be trained and supervised by a parent.
  4. Never allow adults to operate this machine without proper instruction.
  5. Keep bystanders, helpers, pets, and children at least 75 feet from the machine while it is in operation. Stop machine if anyone enters the area.
  6. Never run an engine indoors or in a poorly ventilated area. Engine exhaust contains carbon monoxide, an odorless and deadly gas.
  7. Do not put hands and feet near rotating parts or in the feeding chambers and discharge opening. Contact with the rotating impeller can amputate fingers, hands, and feet.
  8. Never attempt to unclog either the feed intake or discharge opening, remove or empty vacuum bag, or inspect and repair the machine while the engine is running. Shut the engine off and wait until all moving parts have come to a complete stop. Disconnect the spark plug wire and ground it against the engine.
2. Always wear safety glasses or safety goggles during operation or while performing an adjustment or repair, to protect eyes. Thrown objects which ricochet can cause serious injury to the eyes.
  3. Wear sturdy, rough-soled work shoes and close-fitting slacks and shirts. Loose fitting clothes or jewelry can be caught in movable parts. Never operate this machine in bare feet or sandals. Wear leather work gloves when feeding material in the chipper chute.
  4. Before starting, check all bolts and screws for proper tightness to be sure the machine is in safe working condition. Also, visually inspect machine for any damage at frequent intervals.
  5. Maintain or replace safety and instructions labels, as necessary.
  6. To avoid personal injury or property damage use extreme care in handling gasoline. Gasoline is extremely flammable and the vapors are explosive. Serious personal injury can occur when gasoline is spilled on yourself or your clothes which can ignite. Wash your skin and change clothes immediately.
    - a. Use only an approved gasoline container.
    - b. Extinguish all cigarettes, cigars, pipes, and other sources of ignition.
    - c. Never fuel machine indoors.
    - d. Never remove gas cap or add while the engine is hot or running.
    - e. Allow engine to cool at least two minutes before refueling.
    - f. Never over fill fuel tank. Fill tank to no more than 1/2 inch below bottom of filler neck to provide space for fuel expansion.
    - g. Replace gasoline cap and tighten securely.
    - h. If gasoline is spilled, wipe it off the engine and equipment. Move machine to another area. Wait 5 minutes before starting the engine.

### PREPARATION

1. Thoroughly inspect the area where the equipment is to be used. Remove all rocks, bottles, cans, or other foreign objects which could be picked up or thrown and cause personal injury or damage to the machine.

- i. Never store the machine or fuel container inside where there is an open flame, spark, or pilot light (e.g. furnace, water heater, space heater, clothes dryer, etc.)
  - j. To reduce a fire hazard, keep machine free of grass, leaves, or other debris build-up. Clean up oil fuel spillage and remove any fuel soaked debris.
  - k. Allow machine to cool at least 5 minutes before storing.
- 9. Never operate without either the inlet nozzle or optional hose attachment properly attached to the machine. Never attempt to attach or change either attachment while the engine is running.
  - 10. Keep all guards, deflectors and safety devices in place and operating properly.
  - 11. Keep your face and body back and to the side of the chipper chute while feeding material into the machine to avoid accidental kickback injuries.
  - 12. Never operate this machine without good visibility or light. Always be sure of your footing and keep a firm hold on the handles.
  - 13. Do not operate this machine on a gravel surface.
  - 14. Do not operate this machine while under the influence of alcohol or drugs.
  - 15. Muffler and engine become hot and can cause a burn. Do not touch.
  - 16. Never pick up or carry machine while the engine is running.

## OPERATION

1. Do not put hands and feet near rotating parts or in the feeding chambers and discharge opening. Contact with the rotating impeller can amputate fingers, hands, and feet.
2. Before starting the machine, make sure the chipper chute, feed intake, and cutting chamber are empty and free of all debris.
3. Thoroughly inspect all material to be shredded and remove any metal, rocks, bottles, cans, or other foreign objects which could cause personal injury or damage to the machine.
4. If the impeller strikes a foreign object or if your machine should start making an unusual noise or vibration, immediately shut the engine off. Allow the impeller to come to a complete stop. Disconnect the spark plug wire, ground it against the engine and perform the following steps:
  - a. Inspect for damage.
  - b. Repair or replace any damaged parts.
  - c. Check for any loose parts and tighten to assure continued safe operation.
5. Do not allow an accumulation of processed material to build up in the discharge area. This can prevent proper discharge and result in kickback of material through the feed opening.
6. Do not attempt to shred or chip material larger than specified on the machine or in this manual. Personal injury or machine damage could result.
7. Never attempt to unclog either the feed intake or discharge opening while the engine is running. Shut the engine off, wait until all moving parts have stopped, disconnect the spark plug wire and ground it against the engine before clearing debris.
8. Never operate without vacuum bag and discharge chute properly attached to the machine. Never empty or change vacuum bag while the engine is running. Rear end of vacuum bag must be kept closed at all times during operation.

## MAINTENANCE AND STORAGE

1. Never tamper with safety devices. Check their proper operation regularly.
2. Check bolts and screws for proper tightness at frequent intervals to keep the machine in safe working condition. Also, visually inspect machine for any damage and repair, if needed.
3. Before cleaning, repairing, or inspecting, stop the engine and make certain the impeller and all moving parts have stopped. Disconnect the spark plug wire and ground it against the engine to prevent unintended starting.
4. Do not change the engine governor settings or overspeed the engine. The governor controls the maximum safe operating speed of the engine.
5. Maintain or replace safety and instruction labels, as necessary.
6. Follow this manual for safe loading, unloading, transporting, and storage of this machine.
7. Never store the machine or fuel container inside where there is an open flame, spark or pilot light such as a water heater, furnace, clothes dryer, etc.
8. Always refer to the operator's manual for proper instructions on off-season storage.
9. If the fuel tank has to be drained, do this outdoors.
10. Observe proper disposal laws and regulations for gas, oil, etc. to protect the environment.

## ASSEMBLY

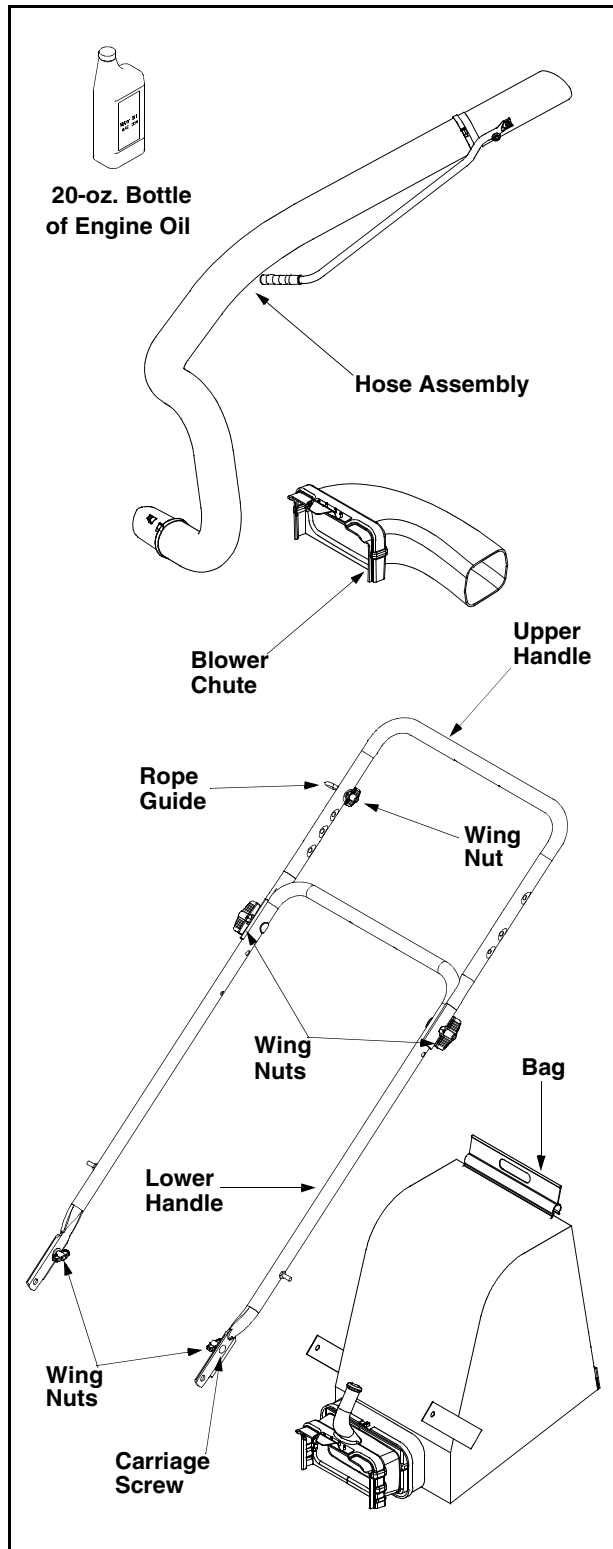

Figure 1

**IMPORTANT:** This unit is shipped **without gasoline or oil in the engine**. After assembly, see OPERATION section of this manual for proper fuel and engine oil fill-up.

**NOTE:** Reference to right and left hand side of the Yard Vacuum is observed from the operating position. See Figure 1.

This Yard Vacuum has been completely assembled at the factory, except for the handle, bag, and blower chute. These parts are shipped loose in the carton. A pair of safety glasses and a 20-oz. bottle of engine oil are also included in the carton. See Figure 1.

### REMOVING UNIT FROM CARTON

- Cut the corners of the carton.
- Remove all loose parts.
- Remove packing material.
- Lift unit from the rear to discard packing material from under unit and roll unit out of carton.
- Check carton thoroughly for any other loose parts.

### LOOSE PARTS IN CARTON (See Figure 1)

- Handle Assembly
- Hose Assembly
- Bag
- Blower Chute
- Safety Glasses (Not Shown)
- A 20-oz. Bottle of Engine Oil (may be located in bag)
- Operator's Manual

### DISCONNECTING SPARK PLUG

Before proceeding with assembly of your new Yard Vacuum, disconnect the spark plug wire from the spark plug and ground onto the retaining post on the engine. This will prevent accidental starting of the engine. See Figure 2.

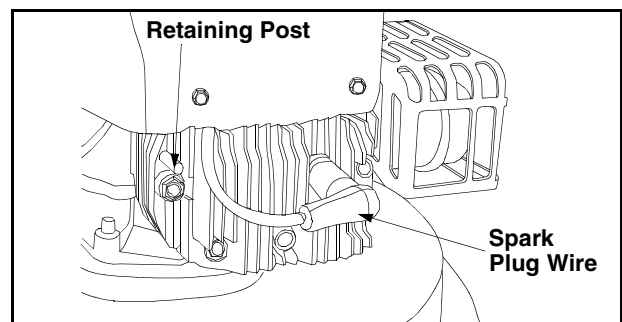

Figure 2

### ATTACHING THE HANDLE

- Unfold the upper handle until it aligns with lower handle. Make sure the rope guide is on the right side of upper handle. See Figure 1.

- Secure the two handles by tightening the upper wing nuts (carriage bolts must be seated properly into the handle).
- Remove the hairpin clips from the handle brackets and remove the carriage bolts and wing nuts from the lower handle. See Figure 3.
- Place the bottom holes in lower handle over the pins on handle brackets and secure with hairpin clips.
- Insert carriage bolts through upper hole in lower handle from the outside and secure with wing nuts.

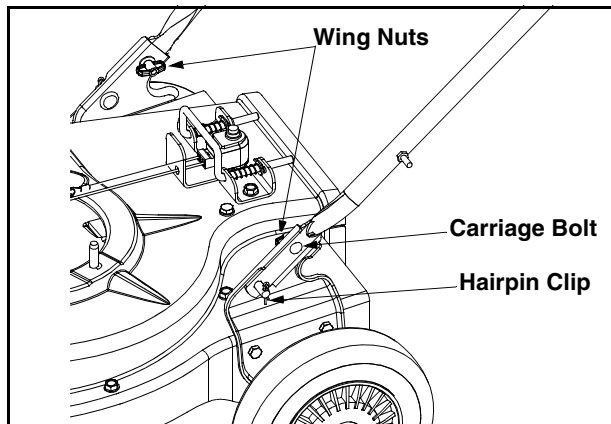

Figure 3

- Loosen the wing nut that secures the rope guide to the right side of upper handle.
- Pull the starter rope out of the engine slowly and slip the starter rope into the rope guide. Tighten the wing nut.

## Attaching The Hose Assembly

- Slide hose adapter of hose assembly into the base adapter located on the left front of the Yard Vacuum. See Figure 4.
- Pull spring loaded pin out on the base and align pin with the first hole in the hose adapter.
- Release the pin to lock the hose in place.
- Connect the hose handle near nozzle end of hose to the side bracket on the upper handle. Refer to Figure 7.

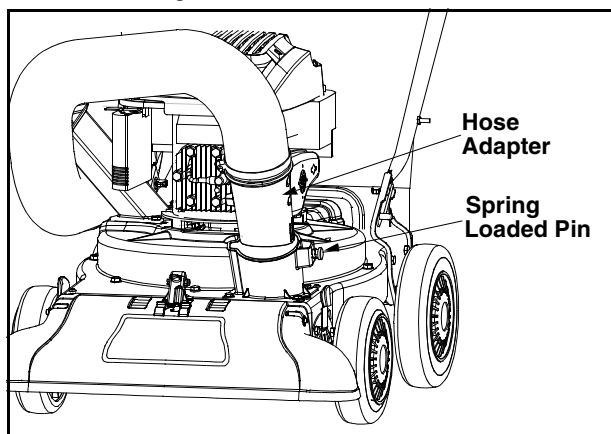

Figure 4

- Snap hose handle to the lower handle bracket to secure in place and lay hose tubing on side bracket hanger next to chipper chute. Refer to Figure 7.

## ATTACHING THE BAG

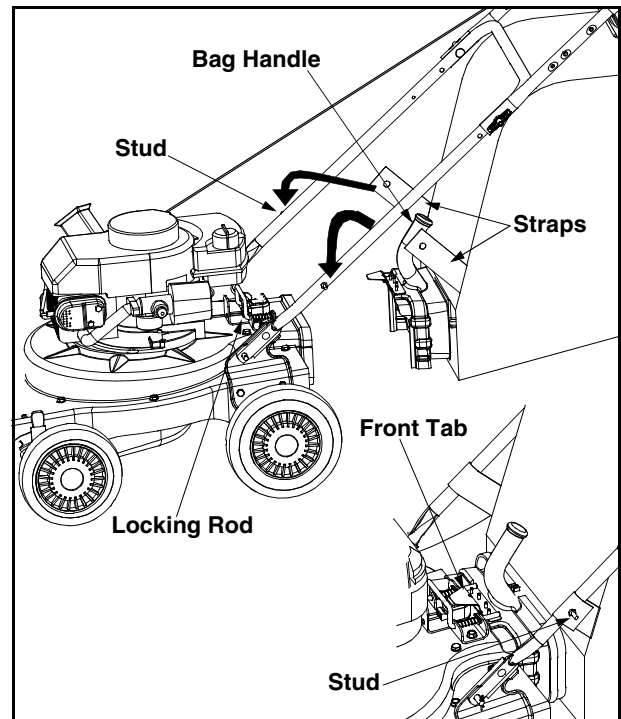

Figure 5

- Grasp bag handle with one hand and slide locking rod on mounting bracket with other hand toward engine. Use the end of mounting bracket as leverage when sliding the locking rod. See Figure 5.
- Slip bag over the rim of the discharge opening and release locking rod to secure bag in place.
- Snap bag clip to the top of the lower handle.
- Place the lower straps on the bag **over** the top of lower handle, hooking them on the studs.

**NOTE:** The bag/chute switch button attached to the mounting bracket must be fully depressed by the tip of front tab on bag handle when securing the bag or engine will not start.

## ATTACHING THE BLOWER CHUTE

**NOTE:** The bag must be removed before installing the blower chute.

- Grasp blower chute with one hand and slide locking rod on mounting bracket with other hand toward engine. Use the end of mounting bracket as leverage when sliding the locking rod. See Figure 6.
- Slip blower chute **over** rim of discharge opening and release locking rod to secure chute in place.

- Raise the nozzle height to the highest setting when using the blower chute. Refer to nozzle height adjustment in the ADJUSTMENT section.

**NOTE:** The bag/chute switch button attached to the mounting bracket must be fully depressed by the tip of front tab on the blower chute or engine will not start.

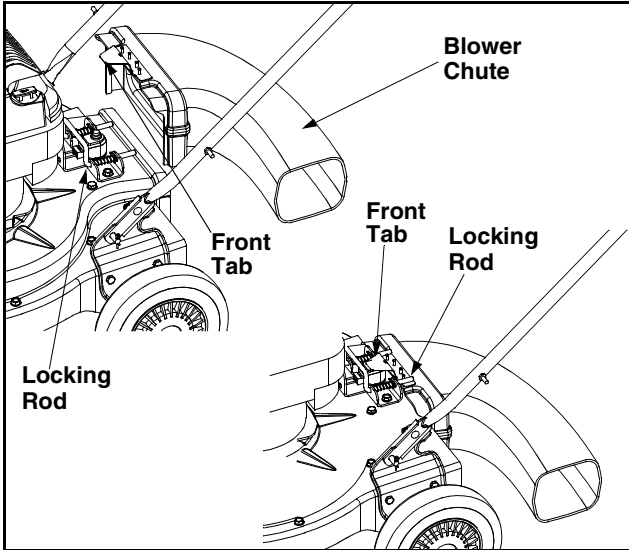

**Figure 6**

# OPERATION

## Know Your Yard Vacuum

Read this operator's manual and safety rules before operating your Yard Vacuum. Compare the illustrations below with your equipment to familiarize yourself with the location of various controls and adjustments. Save this manual for future reference.



The operation of any Yard Vacuum can result in foreign objects being thrown into the eyes, which can result in severe eye damage. **Always wear safety glasses**, provided with the Yard Vacuum, for operating this equipment or while performing any adjustments or repairs on it.

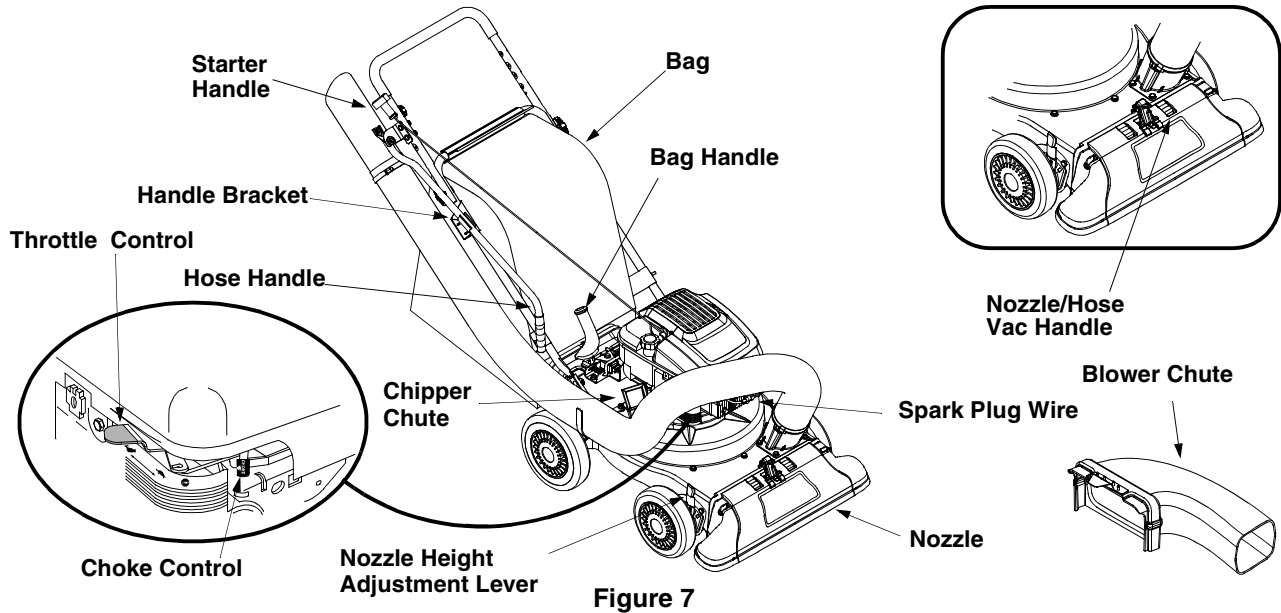

## OPERATING CONTROLS (See Figure 7)

### Chipper Chute

Allows twigs and small branches up to 1 1/2" in diameter to be fed into the impeller for chipping.

### Nozzle

Yard waste such as leaves and pine needles can be vacuumed up through the nozzle for shredding.

### Bag

Collects shredded material fed in through the chipper chute or vacuumed in through the nozzle.

### Blower Chute

When attached to unit, the blower chute is used to blow or scatter yard waste such as leaves, pine needle, or small twigs across yard.

### Bag Handle

Used to grasp bag in order to assist in attaching, removing, and emptying bag.

### Nozzle Height Adjustment Lever

Used to adjust the nozzle ground clearance ranging from 5/8" to 4 1/8".

### Throttle Control

This lever controls the engine speed and stop function. Through three separate positions on the lever from left to right, the operation is as follows:

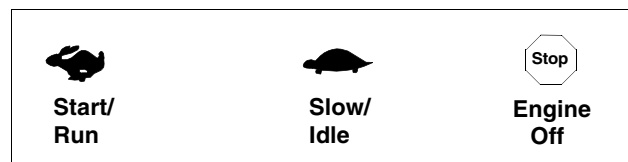

### Choke Control

The choke control is used to choke of the carburetor and assist in starting the engine.

### Starter Handle

Used to start the engine.

## Meets ANSI safety standards

Craftsman Yard Vacuums conform to the safety standard of the American National Standards Institute (ANSI).



## Hose Assembly

Used as an alternative to the nozzle to vacuum yard waste such as leaves or pine needles in hard to reach places.

## Hose Handle

Used to guide hose assembly when vacuuming.

## Nozzle/Hose Vac Handle

The nozzle/hose vac handle is located on top of the nozzle and it is used to regulate the vacuum between the nozzle and the hose assembly.

## GAS AND OIL FILL-UP

### Oil (one 20-oz. bottle shipped with unit)

Only use high quality detergent oil rated with API service classification SF, SG, or SH. Select the oil's SAE viscosity grade according to the expected operating temperature. Follow the chart below.

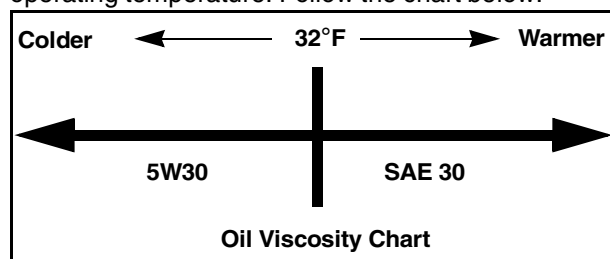

**NOTE:** Although multi-viscosity oils (5W30, 10W30, etc.) improve starting in cold weather, they will result in increased oil consumption when used above 32°F. Check your engine oil level more frequently to avoid possible engine damage from running low on oil.

- Remove oil fill dipstick.
- With the Yard Vacuum on level ground, use a funnel to fill engine with oil to FULL mark on dipstick. Capacity is approximately 20 oz. Be careful not to overfill. Overfilling will cause the engine to smoke profusely and will result in poor engine performance. The oil bottle packaged with your Yard Vacuum contains 20 oz. of oil.
- Check the oil level making certain not to rub the dipstick along the inside walls of the oil fill tube. This would result in a false dipstick reading. Refill to FULL mark on dipstick, if necessary. Replace dipstick and tighten.
- Check oil level three times prior to starting engine to be certain you've gotten an accurate dipstick reading. Running the engine with too little oil can result in permanent engine damage.

### Gasoline

- Remove fuel cap from the fuel tank.
- Make sure the container from which you will pour the gasoline is clean and free from rust or foreign particles. Never use gasoline that may be stale from long periods of storage in its container. Gasoline that has been sitting for any period longer than four weeks should be considered stale.

- Fill fuel tank with clean, fresh, unleaded regular, unleaded premium or reformulated automotive gasoline only. DO NOT use Ethyl or high octane gasoline. Do not use gasoline containing METHANOL. Replace fuel cap.
- To avoid engine problems, the fuel system should be emptied before storage for 30 days or longer. Drain the gas tank, start the engine and let it run until the fuel lines and carburetor are empty. Use fresh fuel next season. See STORAGE section for additional information.



**WARNING:** Use extreme care when handling gasoline. Gasoline is extremely flammable and the vapors are explosive. Never fuel machine indoors or while the engine is hot or running. Extinguish cigarettes, cigars, pipes, and other sources of ignition.

- Check the fuel level periodically to avoid running out of gasoline while operating the Yard Vacuum. If the unit runs out of gas as it is chipping, it may be necessary to unclog the unit before it can be restarted. Refer to SERVICE AND ADJUSTMENT section.

## TO STOP ENGINE

- Move throttle control lever to STOP or OFF position.
- Disconnect spark plug wire and ground it to the post to prevent accidental starting while the equipment is unattended.



**WARNING:** When moving throttle control lever, be careful of heated surfaces and sharp edges on muffler guard.

## TO START ENGINE

1. Attach spark plug wire and rubber boot to spark plug.
2. The bag/chute switch button must be fully depressed by the tip of front tab on bag handle or blower chute for engine to start.
3. Make sure bag/chute switch wire is connected to engine and grounded to mounting bracket.
4. Gas tank should be filled 3/4 to full before starting.
5. Move throttle control to START/RUN position. See Figure 8.
6. Move the choke control toward the throttle control to choke the engine's carburetor. (A warm engine may not require choking.) See Figure 8.

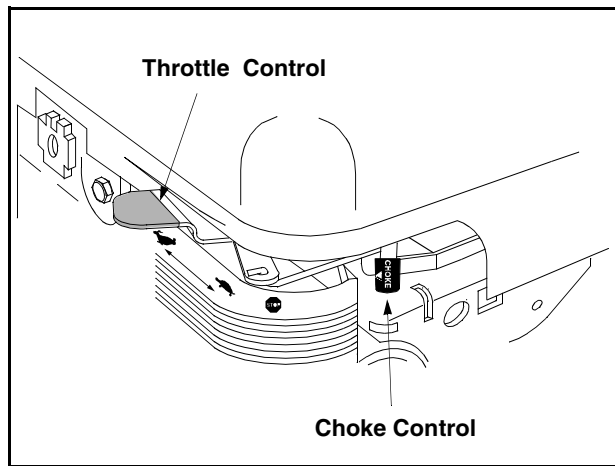

Figure 8

7. Standing behind the unit, grasp starter handle and pull rope out until you feel a drag.
8. Pull the rope with a rapid, continuous, full arm stroke. Keep a firm grip on the starter handle. Let the rope rewind slowly.
9. Repeat, if necessary, until engine starts. When engine starts, move choke control gradually away from the throttle control.
10. If engine falters, move choke control back toward the throttle control and repeat steps 7-9.
11. ALWAYS keep the throttle control in the START/ RUN position when operating the Yard Vacuum.

## TO EMPTY BAG

- Unhook bag straps from the lower handle and unsnap bag clip from top of the lower handle. See Figure 9.
- Grasp bag handle with one hand and pull lock rod on mounting bracket with other hand toward engine to release.
- Remove bag from over the rim of the discharge opening. Refer to Figure 4.
- Twist the two buttons on the back of the bag to unlock and empty contents. See Figure 9.
- Hold bag handle and bag clip while emptying the contents.
- Compress bag opening and fold inner flap over opening.
- Fold outer flap over inner flap and insert buttons on the bag through metal outlets.
- Twist the buttons to lock bag.

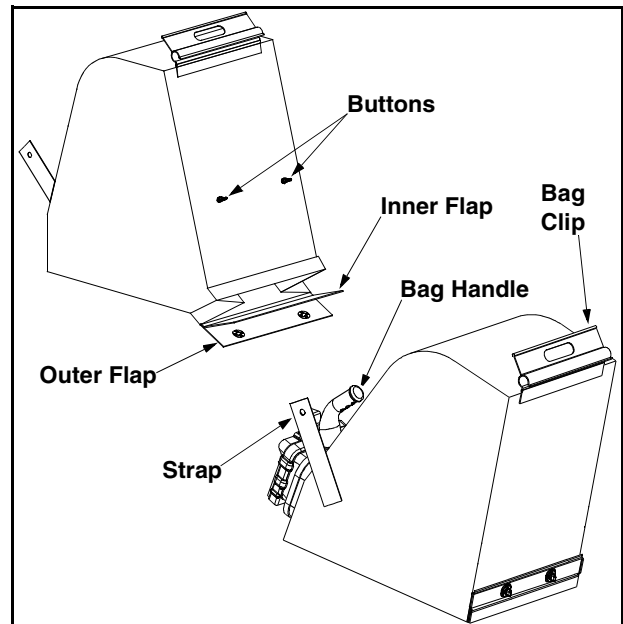

Figure 9

## TO REMOVE BLOWER CHUTE

- Grasp blower chute with one hand and pull lock rod on mounting bracket with other hand toward engine to release. Refer to Figure 6.
- Remove blower chute from over the rim of the discharge opening.

## Using the Nozzle Vacuum

- Place nozzle/hose vac handle in the top position on the nozzle to vacuum through nozzle. See Figure 10.
- The spring loaded pin must be in the first hole of the hose adapter to operate the nozzle vac.
- Place both hands on top of upper handle to push unit over yard waste.

Yard waste such as leaves and pine needles can be vacuumed up through the nozzle for shredding. After material has been shredded by the flail blades on the impeller assembly, it will be discharged into catcher bag or through blower chute. Do not attempt to shred or chip any material other than vegetation found in a normal yard (i.e. branches, leaves, twigs, etc.) Avoid fibrous plants such as tomato vines until they are thoroughly dried out. Materials such as stalks or heavy branches up to 1 1/2" in diameter may be fed into the chipper chute.



**WARNING: Do not attempt to shred, chip, or vacuum any material larger than specified on the machine or in this manual. Personal injury or damage to the machine could result.**

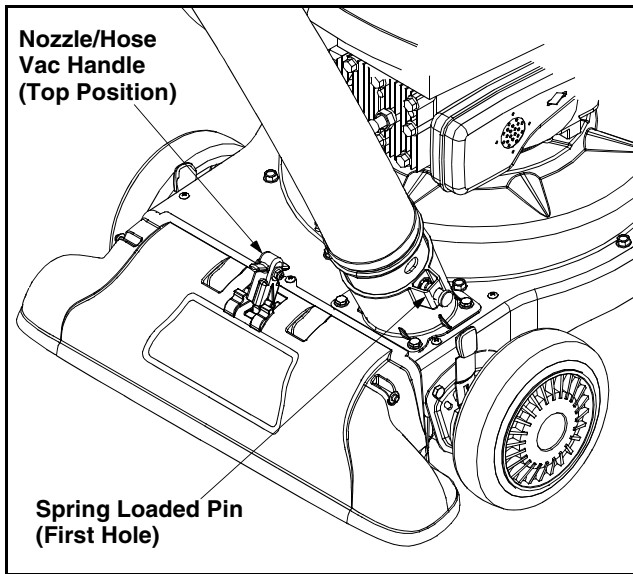

Figure 10

**IMPORTANT:** The flail screen is located inside the housing in the discharge area. If the flail screen becomes clogged, remove and clean as instructed in SECTION 5: MAINTAINING YOUR YARD VACUUM. For best performance, it is also important to keep the chipper blade sharp.



**WARNING:** Do not at any time make any adjustments without first stopping engine and disconnecting spark plug wire.

## Using the Hose Assembly

- Place nozzle/hose vac handle in the bottom position on the nozzle to redirect vacuum to the hose assembly. See Figure 11.
- The spring loaded pin must be in the second hole of the hose adapter to operate the hose assembly.
- Unhook the hose from upper handle bracket and grasp the hose handle to guide while vacuuming yard waste such as leaves or pine needles in hard to reach places.

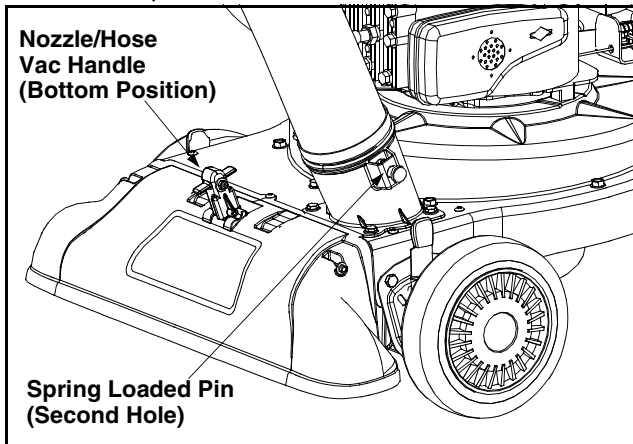

Figure 11

## Nozzle Height Adjustment

The nozzle can be adjusted to any six positions, ranging from 5/8" to 4 1/8" ground clearance. The nozzle height has to be adjusted according to the conditions. Move the height adjustment levers forward or backward to adjust the nozzle upwards or downwards. See Figure 12.

**NOTE:** In general, raise the nozzle height to vacuum a thick layer of leaves or to operate with the blower chute and lower the nozzle height for smoother surfaces.

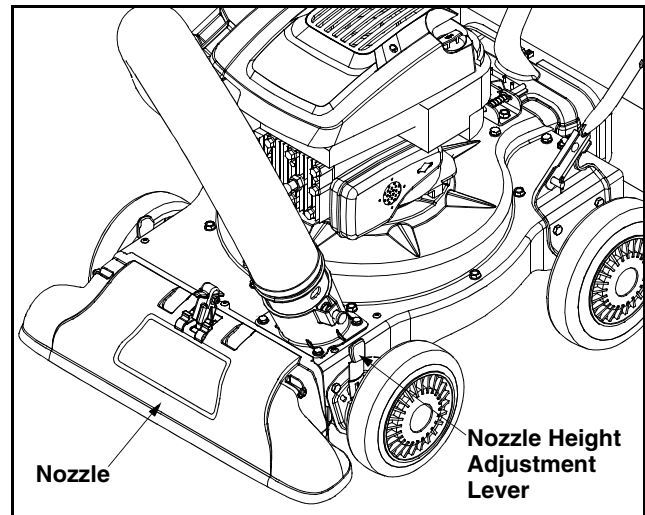

Figure 12

# MAINTENANCE

MAINTENANCE SCHEDULE		Before each use	After each use	First 5 hours	Every 25 hours	Every 50 hours	Before storage
<b>PRODUCT</b>	Lubrication				✓		✓
	Clean equipment		✓				✓
<b>ENGINE</b>	Check engine oil	✓					
	Change engine oil			✓	✓		✓
	Service air cleaner				✓		
	Service spark plug					✓	✓
	Service muffler					✓	
	Clean engine				✓		✓

## GENERAL RECOMMENDATIONS

- Always observe safety rules when performing any maintenance.
- The warranty on this Yard Vacuum does not cover items that have been subjected to operator abuse or negligence. To receive full value from the warranty, operator must maintain the equipment as instructed in this manual.
- Some adjustments will need to be made periodically to maintain your equipment properly.
- Follow the maintenance schedule.
- Periodically check all fasteners and make sure they are tight.



**WARNING:** Always stop the engine and disconnect and ground the spark plug wire before performing any maintenance or adjustments.

## LUBRICATION

- **Wheels-** Place a few drops of SAE 30 oil on each shoulder screw once a season. Refer to Figure 7.
- **Nozzle height adjustment levers-** Lubricate nozzle height adjustment levers with light oil. Refer to Figure 7.
- **Locking Rod-** Lubricate the lock rod and compression springs which attach to the mounting bracket. Refer to Figure 5.

## CLEAN EQUIPMENT

- Clean the Yard Vacuum thoroughly after each use.
- Wash the bag periodically with water. Allow to dry thoroughly in the shade.
- If the flail screen becomes clogged, remove and clean as instructed in the SERVICE AND ADJUSTMENT section.

**NOTE:** Cleaning with a forceful spray of water is not recommended as it could contaminate the fuel system.

## CHECK ENGINE OIL

- Remove oil fill dipstick.
- Check oil level on dipstick. Level should be at FULL mark.
- Replace dipstick and tighten.

## CHANGE ENGINE OIL

- Only use high quality detergent oil rated with API service classification SF, SG, or SH. Select the oil's SAE viscosity grade according to the expected operating temperature. Refer to operation section for viscosity chart.
- Stop engine and wait several minutes before checking oil level. With engine on level ground, the oil must be to FULL mark on dipstick.
- Change engine oil after the first five hours of operation, and every twenty-five hours thereafter.

## TO DRAIN OIL

Drain oil while engine is warm. Follow the instructions given below.

- Drain the gas tank, start the engine and let it run until the fuel line and carburetor are empty.
- Remove oil fill dipstick.
- Tip unit on its side to drain through the oil fill tube.
- When engine is drained of all oil, refill with approximately 20 oz. of fresh oil. Refer to **Gas And Oil Fill-up** in OPERATION section.
- Replace dipstick.

## SERVICE AIR CLEANER

The air cleaner prevents damaging dirt, dust, etc., from entering the carburetor and being forced into the engine and is important to engine life and performance. The air cleaner consists of a foam filter. **Never run** the engine without an air cleaner completely assembled.

### To Service Air Cleaner:

- Remove foam filter from plastic housing on top of engine.
- Wash in water and detergent solution, and squeeze (do not twist) until all dirt is removed.
- Rinse thoroughly in clear water.
- Wrap in a clean cloth and squeeze (do not twist) until completely dry, or allow to air dry.
- Saturate with engine oil and squeeze to distribute oil and remove excess oil.
- Replace foam filter in plastic housing

**NOTE:** If the foam filter is torn or damaged in any way, replace it.



**WARNING: WARNING:** Temperature of muffler and nearby areas may exceed 150° F(65°C). Avoid these areas.

## SERVICE SPARK PLUG

- Clean the spark plug and reset the gap to .030" at least once a season or every 50 hours of operation. See Figure 13. Spark plug replacement is recommended at the start of each season. Refer to engine parts list for correct spark plug type.

**NOTE:** Do not sandblast spark plug. Spark plug should be cleaned by scraping or wire brushing and washing with a commercial solvent.

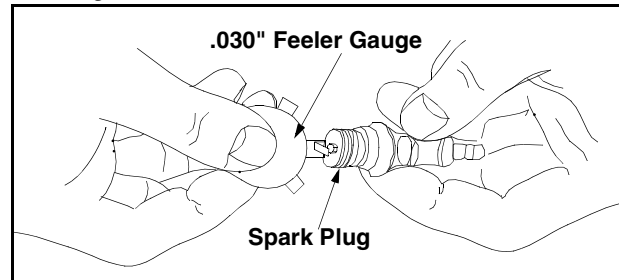

Figure 13

## SERVICE MUFFLER

- Inspect muffler periodically, and replace if necessary.
- If your engine is equipped with a spark arrester screen assembly, remove after every 50 hours of use for cleaning and inspection. Replace if damaged.



**WARNING:** Do not operate the Yard Vacuum without a muffler or tamper with the exhaust system. Damaged mufflers or spark arresters could create a fire hazard.

## CLEAN ENGINE

- Clean engine by removing dirt and debris with a cloth or brush.
- Frequently remove grass clippings, dirt, and debris from cooling fins, air intake screen, levers, and linkage. This will help ensure adequate cooling and engine speed.

## SERVICE AND ADJUSTMENTS



**WARNING:** Do not at any time make any adjustment to the unit without first stopping engine and disconnecting spark plug wire.

### Nozzle Height Adjustment

The nozzle can be adjusted to any six positions, ranging from 5/8" to 4 1/8" ground clearance. The nozzle height has to be adjusted according to the conditions. Move the height adjustment levers forward or backward to adjust the nozzle upwards or downwards. See Figure 14.

**NOTE:** In general, raise the nozzle height to vacuum a thick layer of leaves or to operate with the blower chute and lower the nozzle height for smoother surfaces.

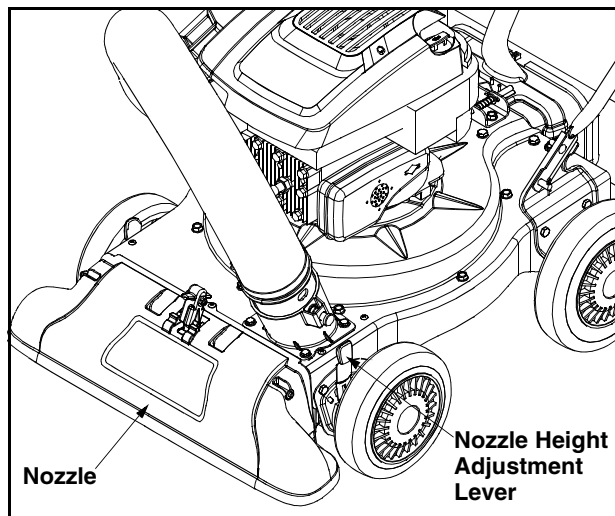

Figure 14

### CARBURETOR ADJUSTMENT



**WARNING:** If any adjustments (e.g. carburetor) are made to the engine while the engine is running, keep clear of all moving parts. Be careful of heated surfaces and muffler.

The carburetor has been pre-set at the factory and should not require adjustment. If your engine does not operate properly due to suspected carburetor problems, take your Yard Vacuum to a Sears Service Center for repair and adjustment.

### ENGINE SPEED

The engine speed on your Yard Vacuum has been set at the factory. Do not attempt to increase the engine RPM. If you think that the engine is running too fast or too slow, take your Yard Vacuum to the nearest Sears Service Center for repair and adjustment.



**WARNING:** Do not attempt to alter the engine speed by tampering with the engine's governor linkage. Doing so could result in serious personal injury and damage to the engine. The engine RPM has been set at the factory.

### REMOVING THE FLAIL SCREEN

If the discharge area becomes clogged, remove the flail screen and clean area as follows.

- Stop the engine. Make certain the chipper shredder vacuum has come to a complete stop.
- **Disconnect and ground the spark plug wire** before unclogging the discharge chute.
- Remove the vacuum bag or blower chute from the unit as instructed in the OPERATION section to obtain access to flail screen. See Figure 15.

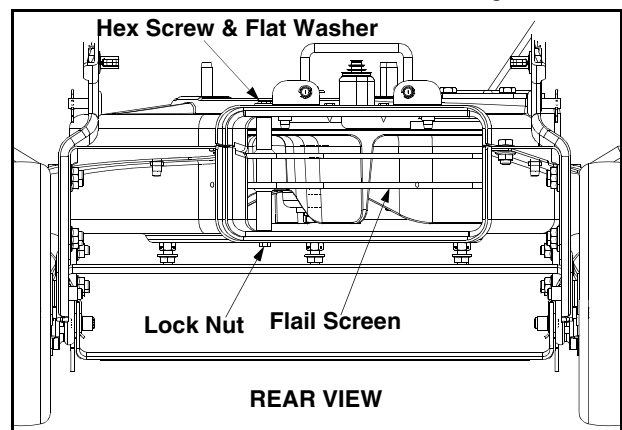

Figure 15

- Remove hex screw on right side of unit that attaches to the flail screen. See Figure 16.

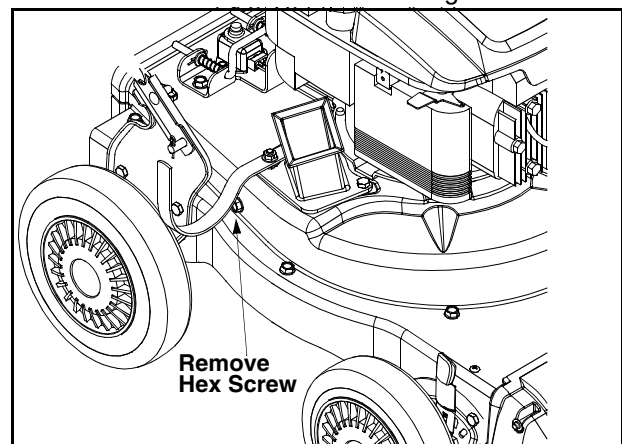

Figure 16

- Remove hex screw and flat washer on top of rear housing near mounting bracket and the lock nut that secures flail screen. See Figure 15.
- Remove and clean the screen by scraping or washing with water. Reinstall the screen.

## SHARPENING OR REPLACING CHIPPER BLADE

Because the engine on this unit has a tapered crankshaft, a special impeller removal tool (part number 753-0900) is required to remove the impeller assembly. For further assistance, contact your Sears Service Center.

**NOTE:** When tipping the unit, empty the fuel tank and keep engine spark plug side up.

- **Disconnect and ground the spark plug wire.**
- Remove the front hubcaps, lock nuts, front wheels, and wave washers that attach to the pivot arm assemblies. See Figure 17.
- Remove the shoulder screws and bell washers that go through the pivot arms and height bracket adjusters to the front support brace.

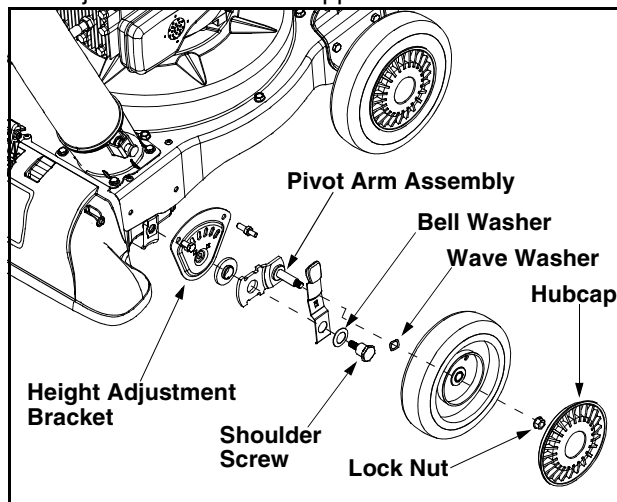

Figure 17

- Remove the three screws on the upper housing that secure the nozzle cover and the nine screws that secure the lower housing to the upper housing. See Figure 18.

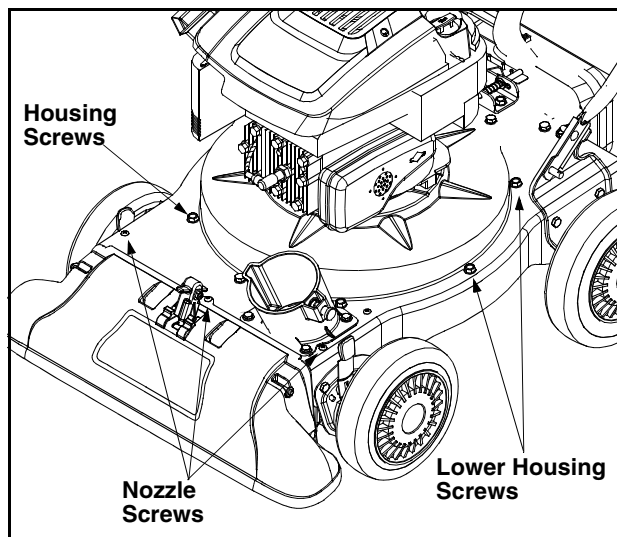

Figure 18

- Remove lock nut that secures flail screen to the lower housing. The flail screen does not have to be removed. Refer to Figure 15.
- Remove the hex bolt, lock washer, and flat washer that secure the impeller assembly to the crankshaft. See Figure 19.

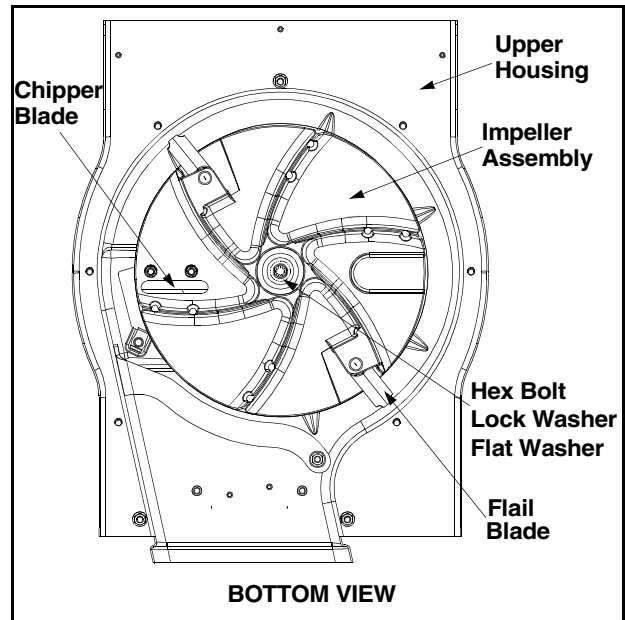

Figure 19

- Apply lubricant to the threads of impeller removal tool and then thread the tool into the crankshaft. Stop when the impeller assembly can move on the crankshaft.
- Remove the impeller assembly from the crankshaft. Unthread the impeller removal tool from the impeller assembly.
- Remove the chipper blade using a 3/16" allen wrench on the outside of the blade and 1/2" wrench on the underside of impeller assembly.
- Replace or sharpen chipper blade.
- When sharpening blade, protect hands by using gloves and follow the original angle of grind.
- Reassemble by performing the previous steps in reverse order.
  - Tighten blade screws to 210 - 250 in-lbs.
  - Tighten impeller bolt to 375 - 425 in-lbs.

**NOTE:** Make certain chipper blade is reassembled with the sharp edge facing upward. See Figure 20.

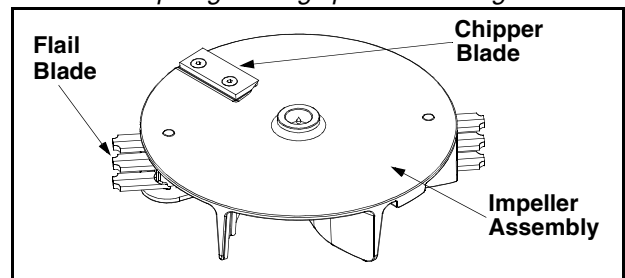

Figure 20

## STORAGE

Prepare your Craftsman Yard Vacuum for storage at the end of the season or if the unit will not be used for 30 days or longer. A yearly check-up by your local Sears Service Center is a good way to ensure that the unit runs properly next season.

### Yard Vacuum

- Clean the equipment thoroughly.
- Wipe equipment with an oiled rag to prevent rust. Use a light oil or silicone to wipe.
- Service the engine following instructions below.
- Store unit in a clean, dry area. Do not store next to corrosive materials such as fertilizer.

### Engine

**IMPORTANT:** It is important to prevent gum deposits from forming in essential fuel system parts such as the carburetor, fuel filter, fuel hose, or tank during storage. Also, alcohol blended fuels (called gasohol or using ethanol or methanol) can attract moisture which leads to separation and formation of acids during storage. Acidic gas can damage the fuel system of an engine while in storage.

To avoid engine problems, the fuel system should be emptied before storage of 30 days or longer. Follow these instruction:

- Drain the fuel tank.
- Start the engine and let it run until the fuel lines and carburetor are empty.
- Drain carburetor.
- Never use engine or carburetor cleaner products in the fuel tank or permanent damage may occur.

**NOTE:** *Fuel stabilizer is an acceptable alternative in minimizing the formation of fuel gum deposits during storage.*

- Add stabilizer to gasoline in fuel tank or storage container.
- Always follow the mix ratio found on stabilizer container.
- Run engine at least 10 minutes after adding stabilizer to allow the stabilizer to reach the carburetor.
- Do not drain the gas tank and carburetor if using fuel stabilizer. Drain all the oil from the crankcase (this should be done after the engine has been operated and is still warm) and refill the crankcase with fresh oil.

If you have drained the fuel tank, protect the inside of the engine as follows:

- Remove spark plug, pour approximately 1/2 ounce (approximately one tablespoon) of engine oil into cylinder and crank slowly to distribute oil.
- Replace spark plug.

### Other

- Do not store gasoline from one season to another.
- Replace the gasoline can if it starts to rust. Rust and/or dirt in the gasoline will cause problems.
- Store unit in a clean, dry area. Do not store next to corrosive materials, such as fertilizer.

**NOTE:** *If storing in an unventilated or metal storage shed, be certain to rustproof the equipment by coating with a light oil or silicone.*



## TROUBLESHOOTING

Problem	Possible Cause(s)	Corrective Action
Engine fails to start	<ol style="list-style-type: none"> <li>1. Fuel tank empty or stale fuel.</li> <li>2. Spark plug wire disconnected.</li> <li>3. Cannot pull recoil cord.</li> <li>4. Choke not in ON position.</li> <li>5. Faulty spark plug.</li> <li>6. Safety switch not depressed.</li> <li>7. Safety switch wire is not connected to engine or not properly grounded.</li> </ol>	<ol style="list-style-type: none"> <li>1. Fill tank with clean, fresh gasoline. Fuel will not last over thirty days unless a fuel stabilizer is added.</li> <li>2. Connect wire to spark plug.</li> <li>3. Obstruction lodged in impeller. Disconnect spark plug wire and remove lodged object.</li> <li>4. Move CHOKE to ON position.</li> <li>5. Clean, adjust gap or replace.</li> <li>6. Safety switch must be depressed by the front tab on the bag handle when securing the bag.</li> <li>7. Connect safety switch wire to engine connector and ground to mounting bracket.</li> </ol>
Loss of power; operation erratic	<ol style="list-style-type: none"> <li>1. Spark plug wire loose.</li> <li>2. Unit running on CHOKE.</li> <li>3. Blocked fuel line or stale fuel.</li> <li>4. Water or dirt in fuel system.</li> <li>5. Carburetor out of adjustment.</li> <li>6. Low engine RPM.</li> </ol>	<ol style="list-style-type: none"> <li>1. Connect and tighten spark plug wire.</li> <li>2. Move choke lever to OFF position.</li> <li>3. Clean fuel line; fill tank with clean fresh gasoline. Fuel will not last over thirty days unless a fuel stabilizer is used.</li> <li>4. Disconnect fuel line at carburetor to drain fuel tank. Refill with fresh fuel.</li> <li>5. Contact your Sears Service Center.</li> <li>6. Always run engine at full throttle.</li> </ol>
Too much vibration	<ol style="list-style-type: none"> <li>1. Loose parts or damaged impeller.</li> </ol>	<ol style="list-style-type: none"> <li>1. Stop engine immediately and disconnect spark plug wire. Have unit serviced by a Sears Service Center.</li> </ol>
Engine overheats	<ol style="list-style-type: none"> <li>1. Carburetor not adjusted</li> <li>2. Engine oil level low</li> </ol>	<ol style="list-style-type: none"> <li>1. Contact your Sears Service Center.</li> <li>2. Fill crankcase with proper selection of oil.</li> </ol>
Unit does not discharge	<ol style="list-style-type: none"> <li>1. Discharge chute clogged.</li> <li>2. Foreign object lodged in impeller.</li> <li>3. Low engine RPM.</li> <li>4. Vacuum bag is full.</li> </ol>	<ol style="list-style-type: none"> <li>1. Stop engine immediately and disconnect spark plug wire. Clean flail screen and inside of discharge opening. See Maintenance section of this manual.</li> <li>2. Stop engine immediately and disconnect spark plug wire. Remove lodged object.</li> <li>3. Always run engine at full throttle.</li> <li>4. Empty bag.</li> </ol>
Rate of discharge slows considerably or composition of discharged material changes	<ol style="list-style-type: none"> <li>1. Low engine RPM.</li> <li>2. Chipper blade dull.</li> </ol>	<ol style="list-style-type: none"> <li>1. Always run engine at full throttle.</li> <li>2. Replace chipper blade or see your Sears Service Center.</li> </ol>

**NOTE:** For repairs beyond the minor adjustments listed above, please contact your local Sears Service Center.

# PARTS LIST

Sears Craftsman 6.0 H.P. Yard Vacuum Model 247.770550

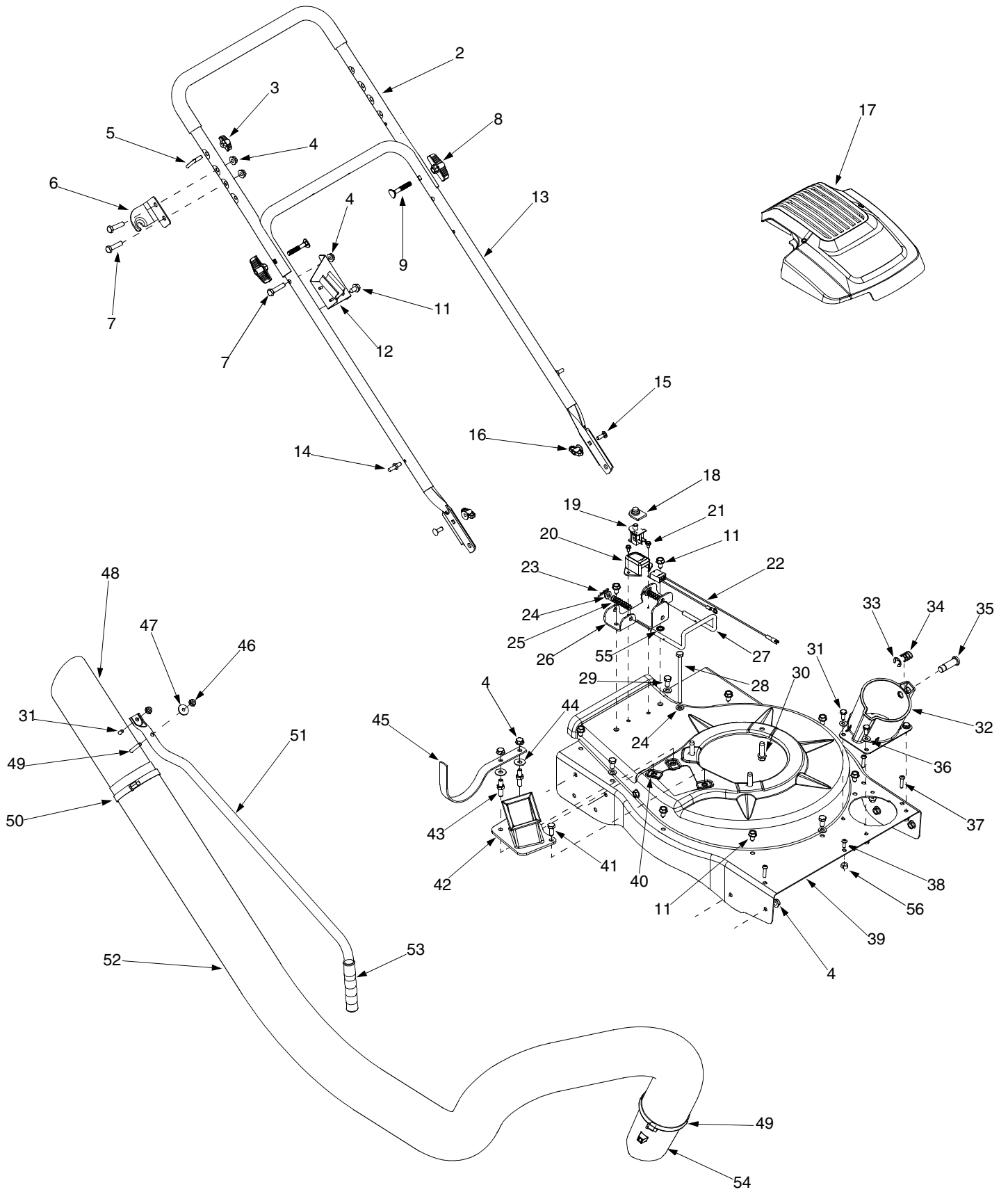

## Sears Craftsman 6.0 H.P. Yard Vacuum Model 247.770550

Ref. No.	Part No.	Part Description	Ref. No.	Part No.	Part Description
2.	749-1423	Upper Handle	30.	710-0502A	Hex Washer Screw 3/8-16 x 1.25
3.	720-0279	Knob	31.	710-0751	Hex Cap Screw 1/4-20 x .620
4.	712-3004A	Flange Lock Nut 5/16-18	32.	731-2484	Hose Base Adapter
5.	710-1205	Eye Bolt	33.	716-0104	E Ring .500 Dia
6.	781-1056	Upper Handle Bracket	34.	732-3035	Compression Spring
7.	710-0528	Hex Cap Screw 5/16-18 x 1.25	35.	711-1571	Clevis Pin
8.	720-0314	Handle Knob 5/16-18	36.	736-3020	Flat Washer ..271 ID x .630 OD
9.	710-1174	Carriage Bolt	37.	710-0969	Screw #12-16 x 1.0
11.	710-0604A	Hex Washer Screw 5/16-18 x.625	38.	710-0425	Machine Screw #10 - 24 x .625
12.	681-0174	Lower Handle Bracket	39.	781-1042	Upper Housing
13.	749-0907B	Lower Handle	40.	726-0454	U-Clip Lock Nut 5/16-18
14.	711-1293	Studs	41.	710-3008	Hex Cap Screw 5/16-18 x.75
15.	710-0703	Carriage Screw 1/4-20 x.75	42.	681-0122	Chipper Chute Assembly
16.	712-0397	Wing Nut 1/4-20	43.	738-1167	Stud 5/16-18 x .56
17.	751B282454	Shroud	44.	736-0371	Flat Washer .343 ID x .880 OD
18.	725-1700	Switch Cover	45.	781-1058	Hose Bracket Hanger
19.	725-3166	Safety Switch	46.	712-3027	Hex Flange Nut 1/4-20
20.	731-1613	Safety Switch Cover	47.	748-0457	Spacer
21.	710-0224	Hex Washer Screw #10-16 x.50	48.	731-2478	Hose Nozzle
22.	629-0920	Wire Harness	49.	710-3288	Hex Cap Screw 1/4-20 x 2.625
23.	714-0104	Cotter Pin	50.	723-0295	Adjustment Clamp
24.	736-0264	Flat Washer.330 ID x.630 OD	51.	749-1270	Nozzle Handle
25.	732-0962	Compression Spring	52.	764-0648	Vacuum Hose
26.	781-0778A	Mounting Bracket	53.	07071	Handle Grip
27.	747-1153	Lock Rod	54.	731-2292	Hose Adapter
28.	710-3195	Hex Cap Screw 5/16-18 x 4.5	55.	736-0607	External L-Washer 5/16
29.	710-3025	Hex Cap Screw 5/16-18 x.625	56.	712-0161	Hex Lock Nut #10 - 24

**NOTE:** For **painted parts**, please refer to the list of color codes below. Please add the applicable color code, wherever needed, to the part number to order a replacement part. For instance, if a part, numbered 700-xxxx, is painted polo green, the part number to order would be 700-xxxx-0689.

Polo Green: 0689  
Oyster Grey: 0662  
Powder Black: 0637

# Sears Craftsman 6.0 H.P. Yard Vacuum Model 247.770550

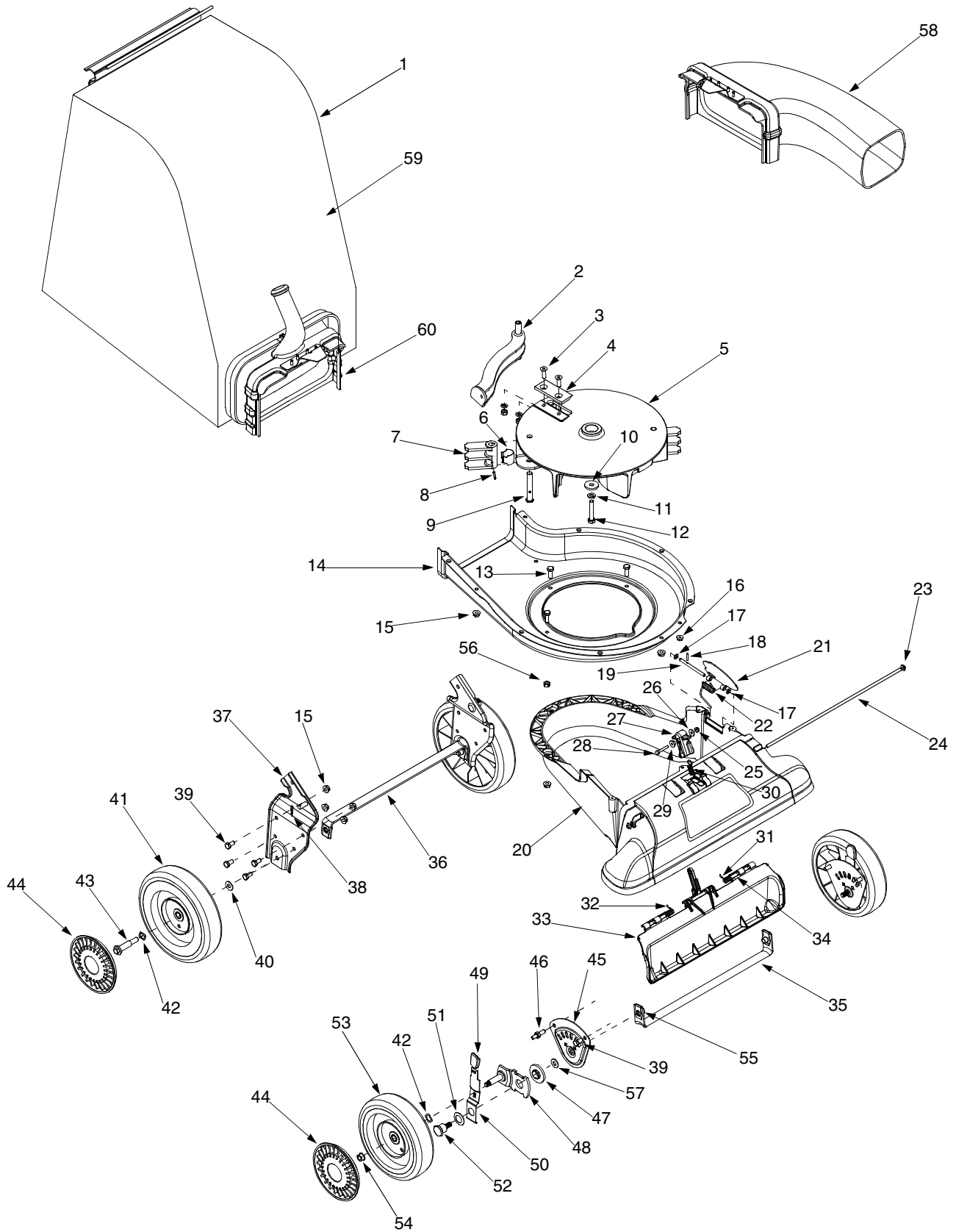

## Sears Craftsman 6.0 H.P. Yard Vacuum Model 247.770550

Ref. No.	Part No.	Part Description	Ref. No.	Part No.	Part Description
1.	664-0094	Bag Assembly	32.	732-1150	Torsion Spring RH
2.	681-0154	Screen Assembly	33.	731-2294	Nozzle Door
3.	710-1054	Hex Screw 5/16-24 x 1.0	34.	711-1582	Rod .25 x 1.25 Lg
4.	781-0490	Chipper Blade	35.	781-0725A	Front Wheel Support Brace
5.	681-0152	Impeller Assembly	36.	781-0777	Rear Wheel Support Brace
6.	781-0735	Pin Clip	37.	681-0155	Handle Bracket Ass'y LH
7.	719-0329	Flail Blade		681-0156	Handle Brkt Ass'y RH (Not Shown)
8.	715-0166	Spiral Pin	38.	714-0104	Cotter Pin
9.	711-1401	Clevis Pin	39.	710-3025	Hex Cap Screw 5/16-18 x .625
10.	736-0247	Flat Washer.375 ID x 1.25 OD	40.	736-0105	Bell Washer.401 ID x.870 OD
11.	736-0217	Lock Washer 3/8	41.	734-1992	Wheel 9 x 2
12.	710-0818	Hex Cap Screw 3/8-24 x 2.0	42.	736-0232	Wave Washer .531 ID x .781 OD
13.	710-3038	Hex Cap Screw 5/16-18 x .875	43.	738-1015	Shoulder Screw 3/8-16
14.	781-0721A	Lower Housing	44.	731-0981A	Hubcap
15.	712-3004A	Flange Lock Nut 5/16-18	45.	781-0785	Height Adjustment Bracket
16.	712-3027	Hex Flange Nut 1/4-20	46.	738-1185	Stud 5/16-18 .56 x .75
17.	736-0142	Flat Washer .281 ID x .50 OD	47.	741-0751	Height Adjustment Bearing
18.	714-0225	Cotter Pin	48.	682-0113	Pivot Arm Assembly
19.	711-1560	Pivot Rod	49.	720-0426	Height Adjustment Knob
20.	731-2294	Nozzle	50.	732-1026	Spring Lever
21.	781-1064	Base Adapter Door	51.	736-0741	Bell Washer .760 ID x .25 OD
22.	732-1156	Torsion Spring	52.	738-1173	Shoulder Screw .750 ID x .625 OD
23.	726-0106	Cap Speed Nut 1/4	53.	734-1978	Wheel 8 x 2
24.	711-1551	Pivot Rod	54.	712-0431	Flange Lock Nut 3/8-16
25.	712-0161	Hex Lock Nut #10-24	55.	726-0453	Lock Nut 3/8-16
26.	736-0400	Flat Washer .194 ID x .62 OD	56.	712-0158	Hex Lock Nut 5/16-18
27.	731-2485	Nozzle Door Lever	57.	736-0314	Thrust Washer .375 ID x .70 OD
28.	710-1156	Hex Screw #10-24 x 1.25	58.	OEM-290-012	Blower Chute (If Equipped)
29.	750-1294	Shoulder Spacer	59.	764-0631	Bag
30.	732-3118	Extension Spring	60.	631-0083	Chute Assembly
31.	732-1151	Torsion Spring LH			

**NOTE:** For **painted parts**, please refer to the list of color codes below. Please add the applicable color code, wherever needed, to the part number to order a replacement part. For instance, if a part, numbered 700-xxxx, is painted polo green, the part number to order would be 700-xxxx-0689.

Polo Green: 0689  
Oyster Grey: 0662  
Powder Black: 0637