

Operator's Manual

CRAFTSMAN®

2 Ton Aluminum / Steel Service Jack

Model 50102

CUSTOMER HELP LINE



Parts and Questions

1-888-448-6746

(English and Spanish)

10 am - 7 pm, Central Time,
Monday-Friday



WARNING: Before using this product, read this Operator's Manual and follow all its Safety Rules and Operating Instructions.

- Safety
- Operation
- Maintenance

Sears Brands Management Corporation, Hoffman Estates, IL 60179 U.S.A.
www.craftsman.com

Printed in China

AIR PURGE PROCEDURE

IMPORTANT: BEFORE FIRST USE, perform the following Air Purge Procedure to remove any air that may have been introduced into the hydraulic system as a result of product shipment and handling.

1

ASSEMBLE AND INSERT HANDLE

See ASSEMBLY on page 3 to assemble handle. Loosen handle socket screw. Insert end of handle into handle socket. Tighten screw.

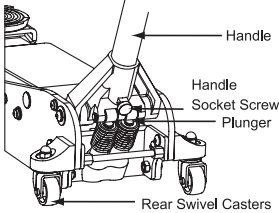

2

TURN HANDLE CLOCKWISE

Turn handle clockwise until it stops to ensure that release valve is closed.

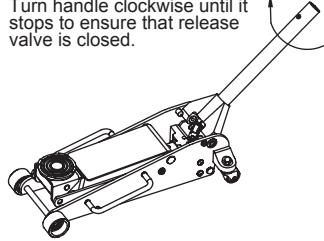

3

TURN HANDLE COUNTERCLOCKWISE

Turn handle counterclockwise 2 full turns to fully open release valve.

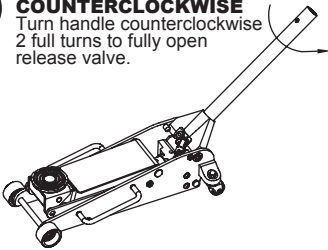

4

RAPIDLY PUMP

Rapidly pump the handle 6 - 8 times. Leave handle in down position to expose oil fill plug.

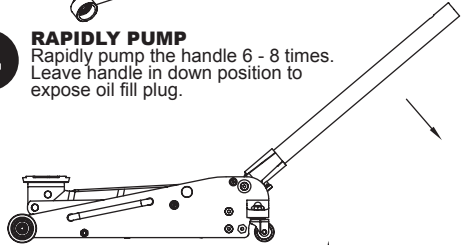

6

TURN HANDLE CLOCKWISE

Turn the handle clockwise until it stops.

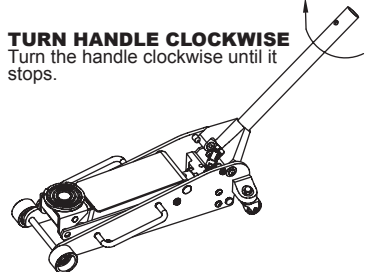

5

PURGE AIR

With a flat blade screwdriver, push the oil fill plug slightly to the side to purge trapped air from system.

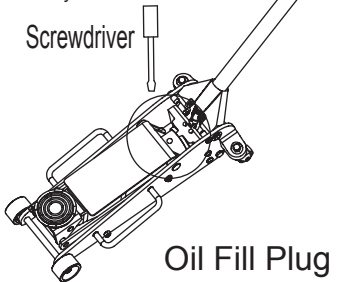

7

READY TO USE

Jack is now ready for use. Check for proper pump action.

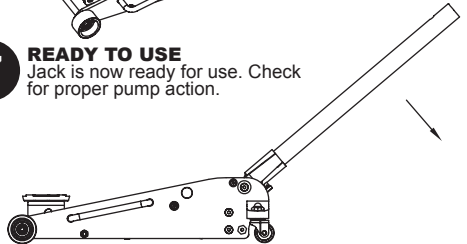

CUSTOMER HELP LINE

Parts and Questions

1-888-448-6746

(English and Spanish)

10 am - 7 pm, Central Time,

Monday-Friday



NOTE: Repeat this Air Purge Procedure whenever the jack displays reduced lifting performance.

SAFETY INSTRUCTIONS

Read Operating Instructions

Study, understand and follow all instructions in this manual before operating the jack. Failure to heed these warnings may result in loss of load, damage to the jack and/or jack failure resulting in personal injury or property damage.

Position the Jack

This jack is designed only for lifting part of the total vehicle. Position the jack to only lift on the areas of the vehicle specified by the vehicle manufacturer.

Use Support Stands

After lifting the vehicle always support the load with appropriately rated vehicle support stands before working on the vehicle.

Do Not Overload Jack

Do not overload this jack beyond its rated capacity. Overloading this jack beyond its rated capacity can cause damage to or failure of the jack.

Use on Hard Level Surface

This jack is designed only for use on hard level surfaces capable of sustaining the load. Use on other than hard level surfaces can result in jack instability and possible loss of load.

Center Load on Jack Saddle

Center load on jack saddle before lifting vehicle. Off-center loads and loads lifted when the jack is not level can cause loss of load or damage to the jack.

Do Not Use Jack as Dolly

Do not move or dolly the vehicle while it is on the jack.

KEEP HANDS AND FEET CLEAR OF THE JACK HINGE MECHANISM AND GROUND CONTACT AREA WHEN LOWERING THE LOAD!

THIS JACK IS A LIFTING DEVICE ONLY!



DO NOT work on vehicle supported by jack. Immediately after lifting, support load with appropriately rated vehicle support stands before working on vehicle.

WARRANTY

CRAFTSMAN ONE YEAR FULL WARRANTY

FOR ONE YEAR from the date of purchase, this product is warranted against any defects in material or workmanship. A defective product be replaced free of charge.

For warranty coverage details to obtain free replacement, visit the web page: www.craftsman.com/warranty

This ONE YEAR warranty is void if this product is ever used while providing commercial services or if rented to another person. For 90 DAY commercial and rental use terms, see the Craftsman warranty web page.

This warranty gives you specific legal rights, and you may also have other rights which vary from state to state.

Sears Brands Management Corporation,
Hoffman Estates, IL 60179

DESCRIPTION

Craftsman model 50102 features a 4,000 lbs. maximum capacity. Lifting range for this jack is 3.87 inches to 18 inches. Jack features an overload valve bypass system to prevent jack damage and user injury.

Specifications

Compact design allows use in confined spaces
Maximum load capacity.....2 tons (4,000 lbs.)
Lift range.....3.87 to 18inches
Weight58 lbs.

WARNING: This product contains chemicals known to the state of California to cause cancer and birth defects or other reproductive harm.

FRONT OF THE JACK

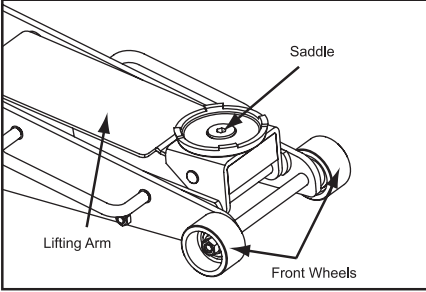

BACK OF THE JACK

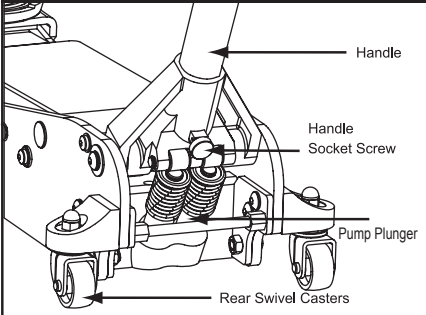

POWER UNIT

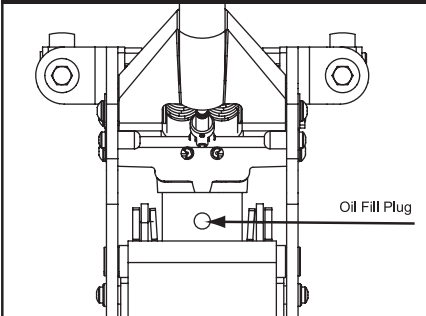

ASSEMBLY

Assembly

Handle Assembly

- Refer to picture 1 when performing this step. Take off the screw located on handle piece 1. Attach handle piece 1 and 2 making sure to align the holes on both pieces. Reinsert the screw and tighten it.
- Carefully remove the Retaining Clip (Picture 3) from the handle socket. **CAUTION:** The socket will tend to spring upward when the clip is removed. To prevent possible injury, place one hand on top of socket to control its upward motion when removing clip with other hand.

- Sufficiently loosen the Handle Socket Screw to insert the assembled handle (Picture 2).
- Line up the square hole located at the bottom of the handle over the square bolt inside the Handle Socket.
- Lower the handle onto the bolt. Secure the handle in place by tightening the Handle Socket Screw.

PICTURE 1

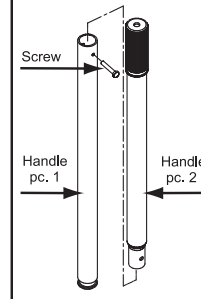

PICTURE 2

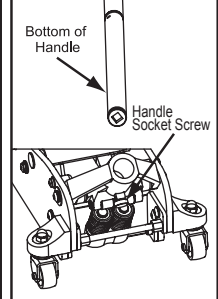

PICTURE 3

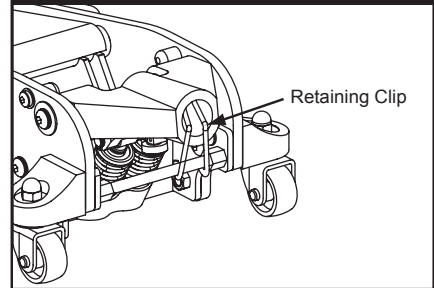

FEATURES & OPERATION

Operation

Raising the Jack

- Block the vehicle's wheels for lifting stability.
- Refer to the vehicle manufacturer owner's manual to locate the approved vehicle lifting points.
- Position the jack so that the saddle will firmly contact the vehicle lifting point.
- Close the release valve by turning the handle clockwise until it stops.
- Pump jack handle until saddle nears contact with vehicle lifting point. Check to see that the saddle is centered and will contact lifting point firmly.
- Continue to pump jack handle to lift vehicle to desired height.
- After lifting, support the load with appropriately rated vehicle support stands before working on vehicle.

Lowering the Jack

- Carefully open the release valve by slowly turning the handle counterclockwise.

How it works

With Release Valve Closed

- An upward stroke of the jack Handle draws oil from the reservoir tank into the plunger cavity. Hydraulic pressure holds the valve closed, which keeps the oil in the plunger cavity.
- A downward stroke of the jack Handle releases oil into the lift cylinder, which forces the power unit ram out. This raises the saddle.
- When the ram reaches maximum extension, oil bypasses the lift cylinder through an overload valve back into the oil reservoir, protecting the jack from damage. This bypass system also goes into effect when the jack is overloaded (load exceeds 4,000 lbs) to protect the jack from damage and the user from possible serious injury.
- Opening the release valve allows oil to flow back into the reservoir. This releases hydraulic pressure on the ram, which results in lowering the saddle.

MAINTENANCE

To Add Oil:

- Position jack on the level ground and lower the saddle.
- Remove the oil plug.
- Fill the oil case until oil level is just beneath the lower rim of oil fill hole. Replace oil plug.
- Perform the Air Purge Procedure detailed on page 1 of this Operator's Manual.

To Replace Oil:

- Fully open release valve by turning handle counterclockwise as far as it will go.
- Turn the jack over so that old oil will drain from the oil fill hole.
- Refill through oil fill hole. Keep dirt and other material clear when pouring. Fill to just beneath lower rim of hole. Replace oil plug.
- Perform Air Purge Procedure detailed on page 1 of this Operator's Manual.

Lubrication

- Add lubricating oil (WD-40) to all moving parts when needed.
- For light duty use, lubricate every six months.
- For heavy and constant use, lubrication is recommended every month.

Rust Prevention:

- Check ram and pump plunger on the Power Unit Assembly every two months (or sooner, based on usage) for any signs of rust or corrosion. Lift the jack as high as it goes and look under and behind the lifting arm. If signs of rust are visible clean as needed and wipe down with an oily cloth or WD-40.
- When storing the jack, always have the saddle and pump plunger in the down position.

ALWAYS USE A GOOD GRADE HYDRAULIC JACK OIL. DO NOT USE HYDRAULIC BRAKE FLUID, ALCOHOL, GLYCERINE, DETERGENT, MOTOR OIL OR DIRTY OIL. USE OF AN UN-RECOMMENDED FLUID CAN CAUSE DAMAGE TO YOUR JACK.

Air Purge Procedure:

During shipment or after oil refill, air may get into the hydraulic system causing reduced lifting performance. Perform Air Purge Procedure as detailed on page 1 of this Operator's Manual.

EXPLODED VIEW AND PARTS LIST

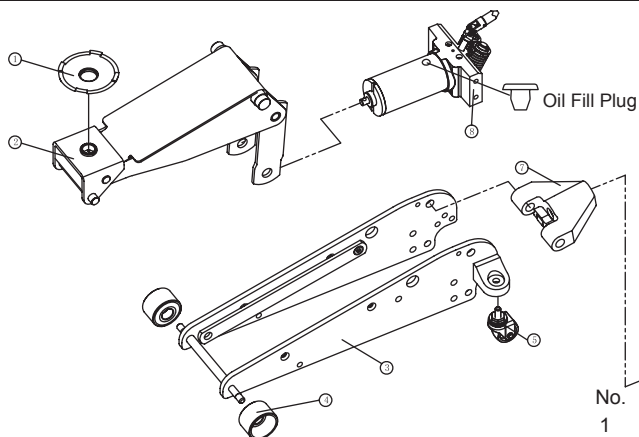

No.	Description	Q'TY
1	Saddle	1
2	Lifting Arm	1
3	Wall Plate Assembly	1
4	Front Wheel	2
5	Rear Caster Assembly	2
6	Handle Assembly	1
7	Handle Socket	1
8	Power Unit Assembly	1

TROUBLESHOOTING

JACK WILL NOT LIFT LOAD	JACK WILL NOT HOLD LOAD	JACK WILL NOT LOWER	POOR JACK LIFTING	CAUSES AND SOLUTIONS
X				Release valve is not completely closed. Turn handle clockwise.
X			X	Air is in the hydraulics. Purge air from system.
X	X		X	Low oil level. Add oil as required.
		X		Oil reservoir is overfilled: Drain excessive oil. Lubricate moving parts.
X	X		X	Power unit malfunctioning. Replace the power unit.

**For Help Line, Parts and Service:
Call 10 am - 7 pm, CT, Monday - Friday
1-888-448-6746**

CRAFTSMAN®

For Help Line, Parts and Service:
Call 10 am - 7 pm, CT, Monday - Friday
1-888-448-6746

Para la línea de ayuda, partes y servicio:
Llame de 10am-7pm Lunes-Viernes
1-888-448-6746