

Owner's Manual

CRAFTSMAN®

7 in. Disc Sander Double Insulated

Model No.
315.115042

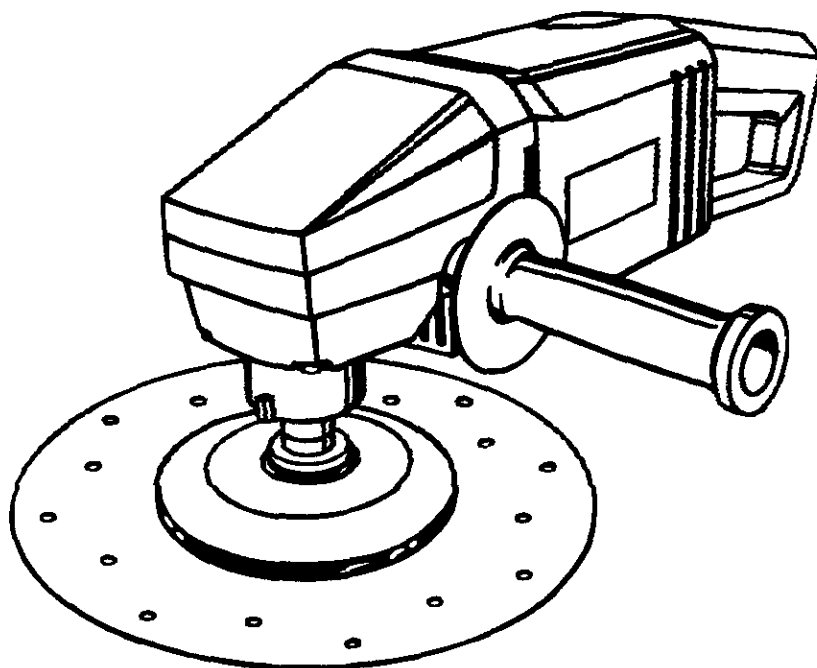

Save this manual for
future reference

CAUTION: Read and follow all
Safety Rules and Operating
Instructions before first use of
this product.

Customer Help Line: 1-800-932-3188

Sears, Roebuck and Co., Hoffman Estates, IL 60179 USA
Visit the Craftsman web page: www.sears.com/craftsman

972000-897

- Table of Contents
- Introduction
- Safety
- Operation
- Maintenance
- Repair Parts



TABLE OF CONTENTS

■ Table of Contents	2
■ Warranty and Introduction	2
■ Rules for Safe Operation	3-4
■ Operation	5-9
■ Accessories	9
■ Maintenance	10
■ Notes	11
■ Exploded View and Parts List	12-13
■ Parts Ordering / Service	14

FULL ONE YEAR WARRANTY ON CRAFTSMAN DISC SANDER

If this **CRAFTSMAN** Disc Sander fails to give complete satisfaction within one year from the date of purchase, **RETURN IT TO THE NEAREST SEARS STORE IN THE UNITED STATES**, and Sears will repair it, free of charge.

If this **CRAFTSMAN** Disc Sander is used for commercial or rental purposes, this warranty applies for only 90 days from the date of purchase.

This warranty gives you specific legal rights, and you may also have other rights which vary from state to state.

Sears, Roebuck and Co., Dept. 817 WA, Hoffman Estates, IL 60179

INTRODUCTION

Your sander has many features for making your sanding operation more pleasant and enjoyable. Safety, performance and dependability have been given top priority in the design of this tool making it easy to maintain and operate.

⚠ CAUTION: Carefully read through this entire owner's manual before using your new sander. Pay close attention to the Rules for Safe Operation, Warnings and Cautions. If you use this tool properly and only for what it is intended, you will enjoy years of safe, reliable service.

PRODUCT SPECIFICATIONS:

Size of Sanding Disc	7 in.
Size of Rubber Back-up Pad	3-1/2 in.
Input	10 Amperes
Rating	120 Volts, 60Hz, AC only
Spindle Size	5/8 in.
No Load Speed	4,600 RPM

⚠ Look for this symbol to point out important safety precautions. It means attention!!! Your safety is involved.

⚠ WARNING:



The operation of any sander can result in foreign objects being thrown into your eyes, which can result in severe eye damage. Before beginning power tool operation, always wear safety goggles or safety glasses with side shields and a full face shield when needed. We recommend Wide Vision Safety Mask for use over eyeglasses or standard safety glasses with side shields. Always wear eye protection which is marked to comply with ANSI Z87.1.

RULES FOR SAFE OPERATION

The purpose of safety symbols is to attract your attention to possible dangers. The safety symbols, and the explanations with them, deserve your careful attention and understanding. The safety warnings do not by themselves eliminate any danger. The instructions or warnings they give are not substitutes for proper accident prevention measures.

SYMBOL

MEANING



SAFETY ALERT SYMBOL:

Indicates danger, warning, or caution. May be used in conjunction with other symbols or pictographs.



DANGER: Failure to obey a safety warning will result in serious injury to yourself or to others. Always follow the safety precautions to reduce the risk of fire, electric shock and personal injury.



WARNING: Failure to obey a safety warning can result in serious injury to yourself or to others. Always follow the safety precautions to reduce the risk of fire, electric shock and personal injury.



CAUTION: Failure to obey a safety warning may result in property damage or personal injury to yourself or to others. Always follow the safety precautions to reduce the risk of fire, electric shock and personal injury.

NOTE:

Advises you of information or instructions vital to the operation or maintenance of the equipment.

DOUBLE INSULATION

Double insulation is a concept in safety, in electric power tools, which eliminates the need for the usual three-wire grounded power cord. All exposed metal parts are isolated from internal metal motor components with protecting insulation. Double insulated tools do not need to be grounded.



WARNING: The double insulated system is intended to protect the user from shock resulting from a break in the tool's internal wiring. Observe all normal safety precautions related to avoiding electrical shock.

READ ALL INSTRUCTIONS

- **KNOW YOUR POWER TOOL.** Read the owner's manual carefully. Learn the tool's applications and limitations as well as the specific potential hazards related to this tool.
- **GUARD AGAINST ELECTRICAL SHOCK** by preventing body contact with grounded surfaces. For example: pipes, radiators, ranges, refrigerator enclosures.
- **KEEP GUARDS IN PLACE** and in working order.
- **KEEP WORK AREA CLEAN.** Cluttered areas and benches invite accidents.
- **DO NOT USE IN DANGEROUS ENVIRONMENTS.** Do not use power tools near gasoline or other flammable liquids, in damp or wet locations, or expose to rain. Keep work area well lit.
- **KEEP CHILDREN AND VISITORS AWAY.** All visitors should wear safety glasses and be kept a safe distance from work area. Do not let visitors contact tool or extension cord.

IMPORTANT

Servicing requires extreme care and knowledge of the system and should be performed only by a qualified service technician. For service we suggest you return the tool to your nearest Sears store or repair center for repair. Always use original factory replacement parts when servicing.



WARNING: Do not attempt to operate this tool until you have read thoroughly and understand completely all instructions, safety rules, etc. contained in this manual. Failure to comply can result in accidents involving fire, electric shock, or serious personal injury. Save owner's manual and review frequently for continuing safe operation and instructing others who may use this tool.

- **STORE IDLE TOOLS.** When not in use, tools should be stored in a dry, high or locked-up place - out of reach of children.
- **DON'T FORCE TOOL.** It will do the job better and safer at the rate for which it was intended.
- **USE RIGHT TOOL.** Don't force small tool or attachment to do the job of a heavy duty tool. Don't use tool for purpose not intended - for example - don't use circular saw for cutting tree limbs or logs.
- **WEAR PROPER APPAREL.** Do not wear loose clothing or jewelry that can get caught in the moving parts and cause personal injury. Rubber gloves and non-skid footwear are recommended when working outdoors. Wear protective hair covering to contain long hair.
- **ALWAYS WEAR SAFETY GLASSES.** Everyday eyeglasses have only impact-resistant lenses; they are **NOT** safety glasses.
- **PROTECT YOUR LUNGS.** Wear a face or dust mask if operation is dusty.

RULES FOR SAFE OPERATION

- **PROTECT YOUR HEARING.** Wear hearing protection during extended periods of operation.
 - **DON'T ABUSE CORD.** Never carry tool by cord or yank it to disconnect from receptacle. Keep cord from heat, oil and sharp edges.
 - **SECURE WORK.** Use clamps or a vise to hold work. It's safer than using your hand and it frees both hands to operate tool.
 - **DON'T OVERREACH.** Keep proper footing and balance at all times. Do not use on a ladder or unstable support.
 - **MAINTAIN TOOLS WITH CARE.** Keep tools sharp and clean for better and safer performance. Follow instructions for lubricating and changing accessories.
 - **DISCONNECT TOOLS.** When not in use, before servicing, or when changing attachments, blades, bits, cutters, etc., all tools should be disconnected from power supply.
 - **REMOVE ADJUSTING KEYS AND WRENCHES.** Form habit of checking to see that keys and adjusting wrenches are removed from tool before turning it on.
 - **MAKE SURE YOUR EXTENSION CORD IS IN GOOD CONDITION.** When using an extension cord, be sure to use one heavy enough to carry the current your product will draw. An undersized cord will cause a drop in line voltage resulting in loss of power and overheating. A wire gage size (A.W.G.) of at least 16 is recommended for an extension cord 100 feet or less in length. A cord exceeding 100 feet is not recommended. If in doubt, use the next heavier gage. The smaller the gage number, the heavier the cord.
 - **OUTDOOR USE EXTENSION CORDS.** When tool is used outdoors, use only extension cords intended for use outdoors and so marked. Outdoor approved cords are marked with the suffix W-A, for example - SJTW-A or SJOW-A.
 - **NEVER USE THIS OR ANY POWER SANDER FOR WET SANDING.** Failure to comply can result in electrical shock causing serious injury or worse.
 - **KEEP HANDS AWAY FROM SANDING AREA.**
 - **INSPECT TOOL CORDS PERIODICALLY** and if damaged, have repaired at an authorized service center. Stay constantly aware of cord location.
 - **CHECK DAMAGED PARTS.** Before further use of the tool, a guard or other part that is damaged should be carefully checked to determine that it will operate properly and perform its intended function. Check for alignment of moving parts, binding of moving parts, breakage of parts, mounting, and any other conditions that may affect its operation. A guard or other part that is damaged should be properly repaired or replaced by an authorized service center unless indicated elsewhere in this instruction manual.
 - **NEVER USE IN AN EXPLOSIVE ATMOSPHERE.** Normal sparking of the motor could ignite fumes.
 - **INSPECT EXTENSION CORDS PERIODICALLY** and replace if damaged.
 - **STAY ALERT.** Watch what you are doing and use common sense. Do not operate tool when you are tired. Do not rush.
 - **KEEP HANDLES DRY, CLEAN, AND FREE FROM OIL AND GREASE.** Always use a clean cloth when cleaning. Never use brake fluids, gasoline, petroleum-based products or any strong solvents to clean your tool.
 - **AVOID ACCIDENTAL STARTING.** Don't carry tool with finger on switch. Be sure switch is off when plugging in.
 - **DO NOT USE TOOL IF SWITCH DOES NOT TURN IT ON AND OFF.** Have defective switches replaced by an authorized service center.
 - **INSPECT FOR** and remove all nails from lumber before sanding.
 - **DRUGS, ALCOHOL, MEDICATION.** Do not operate tool while under the influence of drugs, alcohol, or any medication.
 - **WHEN SERVICING USE ONLY IDENTICAL CRAFTSMAN REPLACEMENT PARTS.**
 - **POLARIZED PLUGS.** To reduce the risk of electric shock, this tool has a polarized plug (one blade is wider than the other). This plug will fit in a polarized outlet only one way. If the plug does not fit fully in the outlet, reverse the plug. If it still does not fit, contact a qualified electrician to install the proper outlet. Do not change the plug in any way.
 - **SAVE THESE INSTRUCTIONS.** Review them frequently and use them to instruct others who may use this tool. If you loan someone this tool, loan them these instructions also.
- ⚠ WARNING:** Some dust created by power sanding, sawing, grinding, drilling, and other construction activities contains chemicals known to cause cancer, birth defects or other reproductive harm. Some examples of these chemicals are:
- lead from lead-based paints,
 - crystalline silica from bricks and cement and other masonry products, and
 - arsenic and chromium from chemically-treated lumber.
- Your risk from these exposures varies, depending on how often you do this type of work. To reduce your exposure to these chemicals: work in a well ventilated area, and work with approved safety equipment, such as those dust masks that are specially designed to filter out microscopic particles.

SAVE THESE INSTRUCTIONS

OPERATION

⚠ WARNING: Always wear safety goggles or safety glasses with side shields when operating your sander. Failure to do so could result in dust, shavings, loose particles or foreign objects being thrown into your eyes, causing possible serious injury.

KNOW YOUR SANDER

See Figure 1.

Before attempting to use your sander, familiarize yourself with all operating features and safety requirements. Your sander is suitable for sanding with coarse, medium, and fine grit sanding discs.

⚠ WARNING: If any parts are missing, do not operate this tool until the missing parts are replaced. Failure to do so could result in possible serious personal injury.

ELECTRICAL CONNECTION

Your sander has a precision built electric motor. It should be connected to a power supply that is 120 volts, 60Hz, AC only (normal household current). Do not operate this tool on direct current (DC). A voltage drop of more than 10 percent will cause a loss of power and the motor will overheat. If your tool does not operate when plugged into an outlet, double-check the power supply.

⚠ WARNING: Do not allow familiarity with your sander to make you careless. Remember that a careless fraction of a second is sufficient to inflict severe injury.

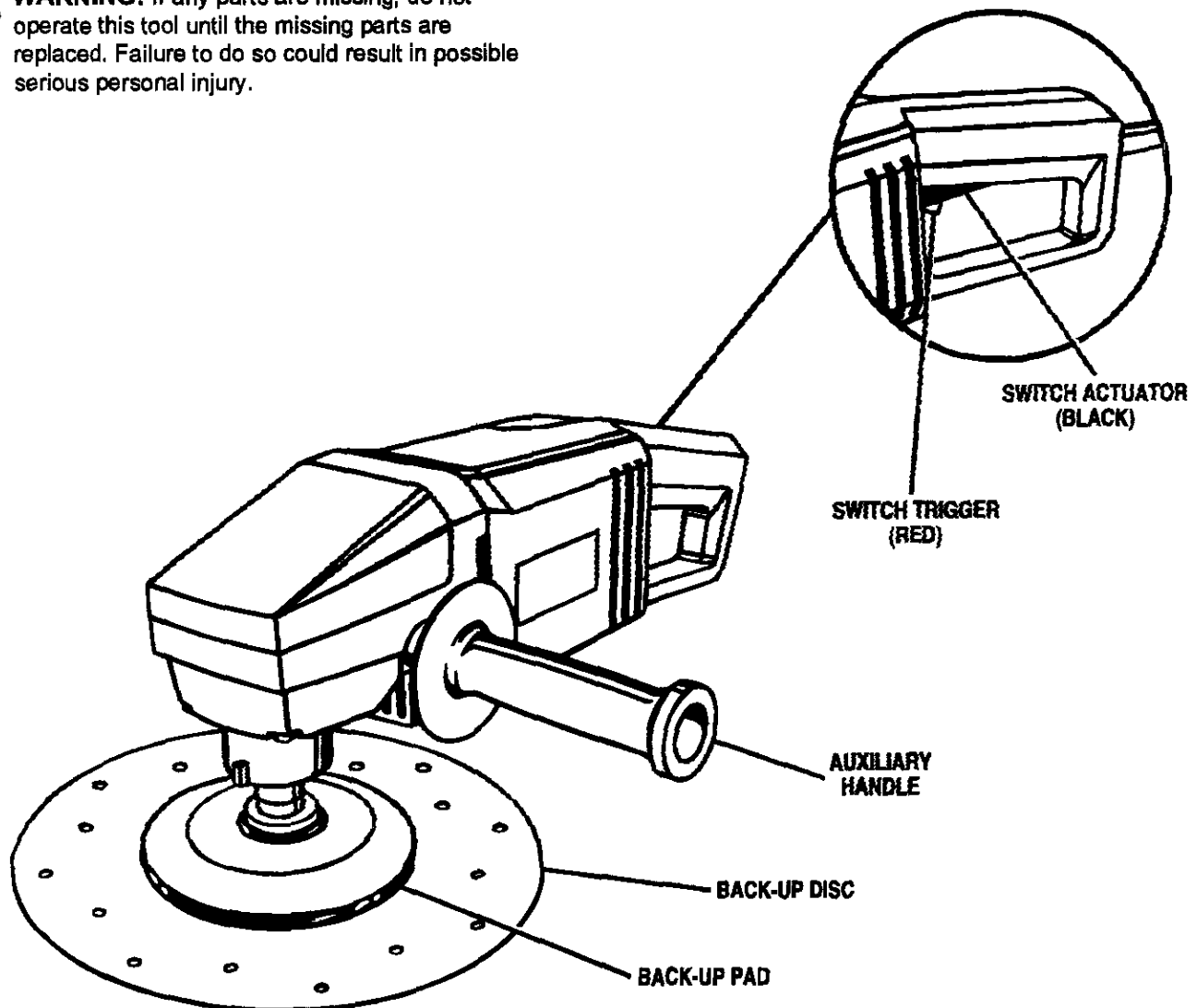

Fig. 1

OPERATION

⚠ WARNING: Your sander should never be connected to power supply when you are assembling parts, making adjustments, cleaning, or when not in use. Disconnecting sander will prevent accidental starting that could cause serious personal injury.

AUXILIARY HANDLE

See Figure 2.

An auxiliary handle is packed with your sander for ease of operation and to help prevent loss of control. Any loss of control could result in an accident, causing possible serious personal injury.

The motor housings are designed so that the auxiliary handle can be installed on either side of the unit.

To install:

- Position washer into place and start threads into the threaded hole in the gear housing.
- Tighten handle securely.

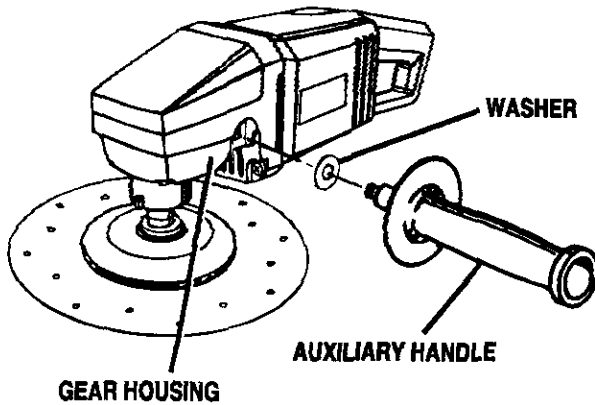

Fig. 2

SPINDLE LOCK BUTTON

See Figure 3.

A spindle lock button has been provided for locking the spindle of your tool in a stationary position. It is located on the side of the gear housing as shown in figure 3. Depress and hold the lock button while installing, changing, or removing accessories.

⚠ CAUTION: Do not engage spindle lock while spindle is rotating.

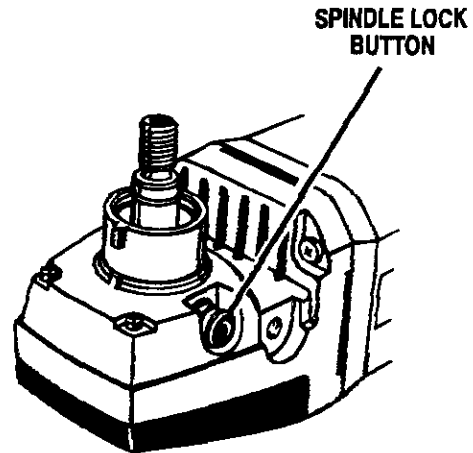

Fig. 3

OPERATION

SWITCH

An important new feature of your sander is the switch design. It has multi-finger control for use when operating at different angles or sanding positions and to help reduce fatigue.

It also has a lock-on feature in the switch for added utility and convenience on extended work requirements.

Carefully read and understand the following instructions for correct operation of the switch before connecting your sander to power supply.

To Activate Switch:

To start your sander, depress the switch trigger and switch actuator at the same time. *See Figure 4.*

Note: The parts of the switch can be easily identified by their color. The switch trigger is red. The switch actuator is black.

"LOCK-ON" FEATURE

- Start your sander by depressing the switch trigger and switch actuator.
- Continue to hold your sander in the **ON** position with your fingertips and release the switch trigger. *See Figures 5 and 6.*
- Release the switch actuator and grasp your sander by the handle as shown in figure 7.

TO RELEASE "LOCK-ON" FEATURE

- Depress the switch trigger and release it. *See Figure 8.*

⚠ WARNING: Before connecting your sander to power supply source, always check to be sure it is not in "lock-on" position. Failure to do so could result in accidental starting of your sander resulting in possible serious injury. Also do not lock the trigger on jobs where your sander may need to be stopped suddenly.

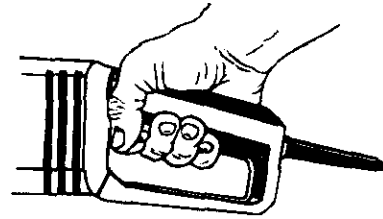

DEPRESS SWITCH TRIGGER AND SWITCH ACTUATOR TO START YOUR SANDER

Fig. 4

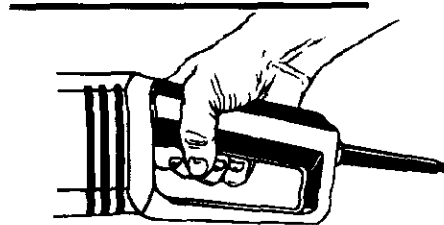

STEP 1: DEPRESS SWITCH TRIGGER AND SWITCH ACTUATOR WITH YOUR FINGERTIPS

Fig. 5

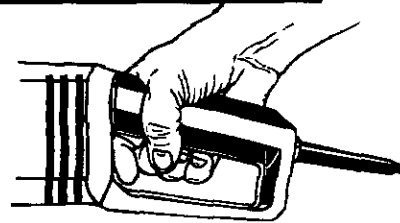

STEP 2: RELEASE SWITCH TRIGGER TO "LOCK-ON"

Fig. 6

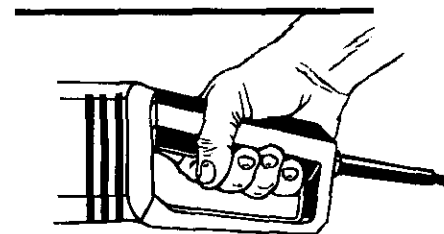

STEP 3: GRASP BY HANDLE FOR SANDING WITH YOUR SANDER IN "LOCK-ON" POSITION

Fig. 7

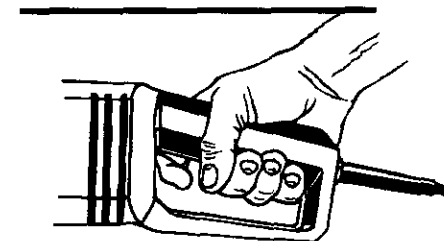

STEP 4: DEPRESS SWITCH TRIGGER TO RELEASE "LOCK-ON" FEATURE

Fig. 8

OPERATION

INSTALLING SANDING DISC

- Disconnect sander from power supply.
- Assemble parts as shown in Figure 9.
- Place washer on spindle, then thread rubber back-up pad onto spindle. Lock spindle by depressing spindle lock button and hand tighten back-up pad.
- Position back-up disc and sanding disc in place and thread flange nut onto spindle. Tighten flange nut securely by turning the sanding disc clockwise by hand.

⚠ WARNING: Use only the back-up pad and back-up disc supplied with your tool. Other types of pads or discs could disintegrate causing possible serious personal injury.

SANDING

See Figure 10.

The material being sanded should be held firmly. Secure small workpiece in a vise or clamp to workbench.

Hold your sander in front and away from you with both hands. With the sanding disc clear of the workpiece, start your sander and let the motor reach its maximum speed, then lower to the work surface at a slight 5 to 8 degree angle. See Figure 10. Do not allow the tool to remain in one place. This will cause uneven sanding or gouging of the work. Keep your sander slowly moving over the work.

⚠ WARNING: Keep a firm grip on the handles of your tool with both hands at all times. Failure to do so could result in loss of control leading to possible serious injury.

This tool was designed so that the weight of the tool alone will provide adequate weight on the sanding disc. Extra pressure will only result in uneven work, slower sanding from slower speed, and possible motor burn-out.

Upon completion of work, or a sanding operation, lift your sander away from work surface before turning off.

⚠ WARNING: Sanding disc must come to a complete stop before setting tool down on workbench. Failure to do so can cause the tool to be thrown from workbench because of sanding disc rotation. This could result in damage to the tool or possible serious personal injury.

To remove paint, varnish, or rust, sand with an openkote type sanding disc.

Another method of removing paint or rust is by wire brushing. The wire cup brush may be threaded directly onto the spindle.

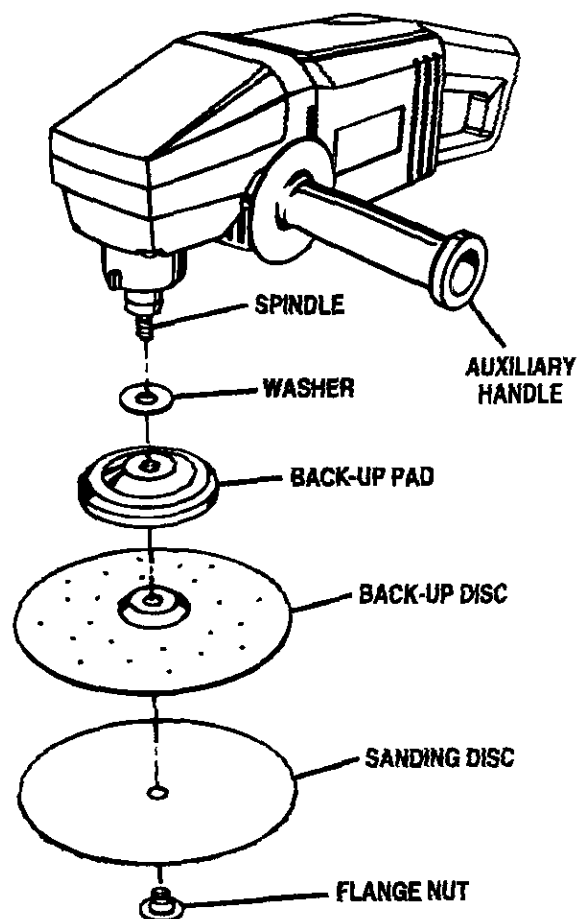

Fig. 9

⚠ WARNING: Always wear protective goggles. Sparks, wire and loose particles can be thrown while using a wire brush. Use of your sander without goggles could result in serious personal injury.

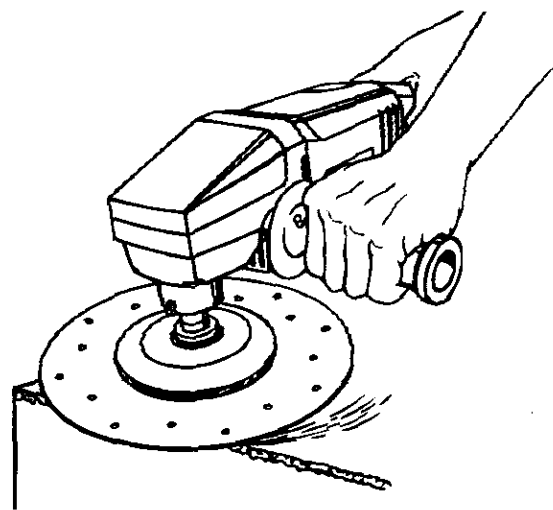
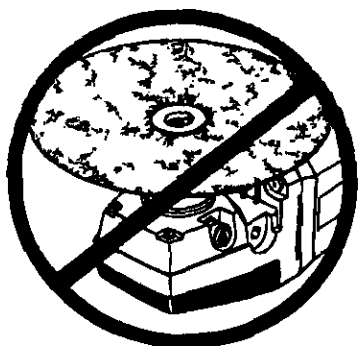

Fig. 10

OPERATION

For ease of operation and maintaining proper control, hold your sander only by the handles provided. Also, as mentioned previously, hold it firmly with both hands at all times. Never grasp the front or sides of the tool body, or by any other means during use.

WARNING: This tool has been designed for hand held use only. To prevent possible serious injury, do not clamp it upside down to a bench and attempt to use it as a bench tool. It would be impossible to control and you would have no protection against dust, sparks, loose particles, etc.



DO NOT ATTEMPT TO USE AS A BENCH TOOL

CAUTION: Because of the rotating disc nature of your tool, always stay constantly aware of the power cord, cord plug, extension cord and extension cord plugs. They could get caught in the rotating spindle, wrap around it, and cause possible serious injury.

WARNING: If you convert your sander to a grinder, you must purchase the appropriate grinding wheel and grinding wheel guard. Any attempt to use this tool as a grinder without a guard would be misuse and could result in possible serious injury.

ACCESSORIES

THE FOLLOWING RECOMMENDED ACCESSORIES ARE CURRENTLY AVAILABLE AT SEARS RETAIL STORES.

7-in. Sanding Kit Item No. ²11157

Aluminum Oxide Sanding Discs

Guard Item No. ²1711
(Available through catalog sales only)

50' 14 A.W.G. Ext. Cord Item No. ²5821

Wire Cup Brush Wheel Item No. ²64106

Carrying Case Item No. ²1472C

Grinding Wheel Item No. ²64101

100' 14 A.W.G. Ext. Cord Item No. ²83508

WARNING: The use of attachments or accessories not listed above might be hazardous.

MAINTENANCE

⚠ WARNING: When servicing use only identical Craftsman replacement parts. Use of any other parts may create a hazard or cause product damage.

GENERAL

Only the parts shown on parts list, page 13, are intended to be repaired or replaced by the customer. All other parts represent an important part of the double insulation system and should be serviced only at a qualified service center.

Avoid using solvents when cleaning plastic parts. Most plastics are susceptible to various types of commercial solvents and may be damaged by their use. Use clean cloths to remove dirt, carbon dust, etc.

⚠ WARNING: Do not at any time let brake fluids, gasoline, petroleum-based products, penetrating oils, etc. come in contact with plastic parts. They contain chemicals that can damage, weaken, or destroy plastic.

When electric tools are used on fiberglass boats, sports cars, wallboard, spackling compounds, or plaster, it has been found that they are subject to accelerated wear and possible premature failure, as the fiberglass chips and grindings are highly abrasive to bearings, brushes, commutators, etc. Consequently it is not recommended that this tool be used for extended work on any fiberglass material, wallboard, spackling compounds, or plaster. During any use on these materials, it is extremely important that the tool is cleaned frequently by blowing with an air jet.

⚠ WARNING: Always wear safety goggles, or safety glasses with side shields during power tool operation or when blowing dust. If operation is dusty, also wear a dust mask.

EXTENSION CORDS

The use of any extension cord will cause some loss of power. To keep the loss to a minimum and to prevent tool overheating, follow the recommended cord sizes on the chart below. When tool is used outdoors, use only extension cords suitable for outdoor use and so marked. Extension cords are available at Sears Retail Stores.

Length of Extension Cord	Wire Size (A.W.G.)
Up to 50 feet	16
50-100 feet	14

⚠ CAUTION: Keep extension cords away from the sanding area and position the cord so that it will not get caught on lumber, tools, etc., during sanding operation.

⚠ WARNING: Check extension cords before each use. If damaged, replace immediately. Never use tool with a damaged cord since touching the damaged area could cause electrical shock resulting in serious injury.

LUBRICATION

All of the bearings in this tool are lubricated with a sufficient amount of high grade lubricant for the life of the unit under normal operating conditions. Therefore, no further lubrication is required.

CRAFTSMAN DISC SANDER – MODEL NUMBER 315.115042

SEE NOTE "A" PAGE 13

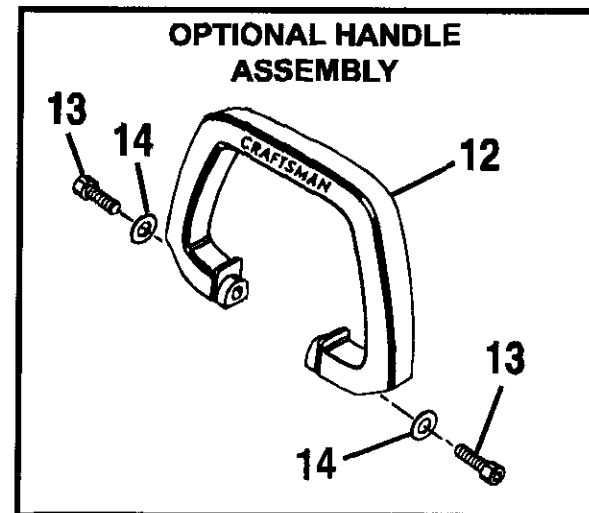
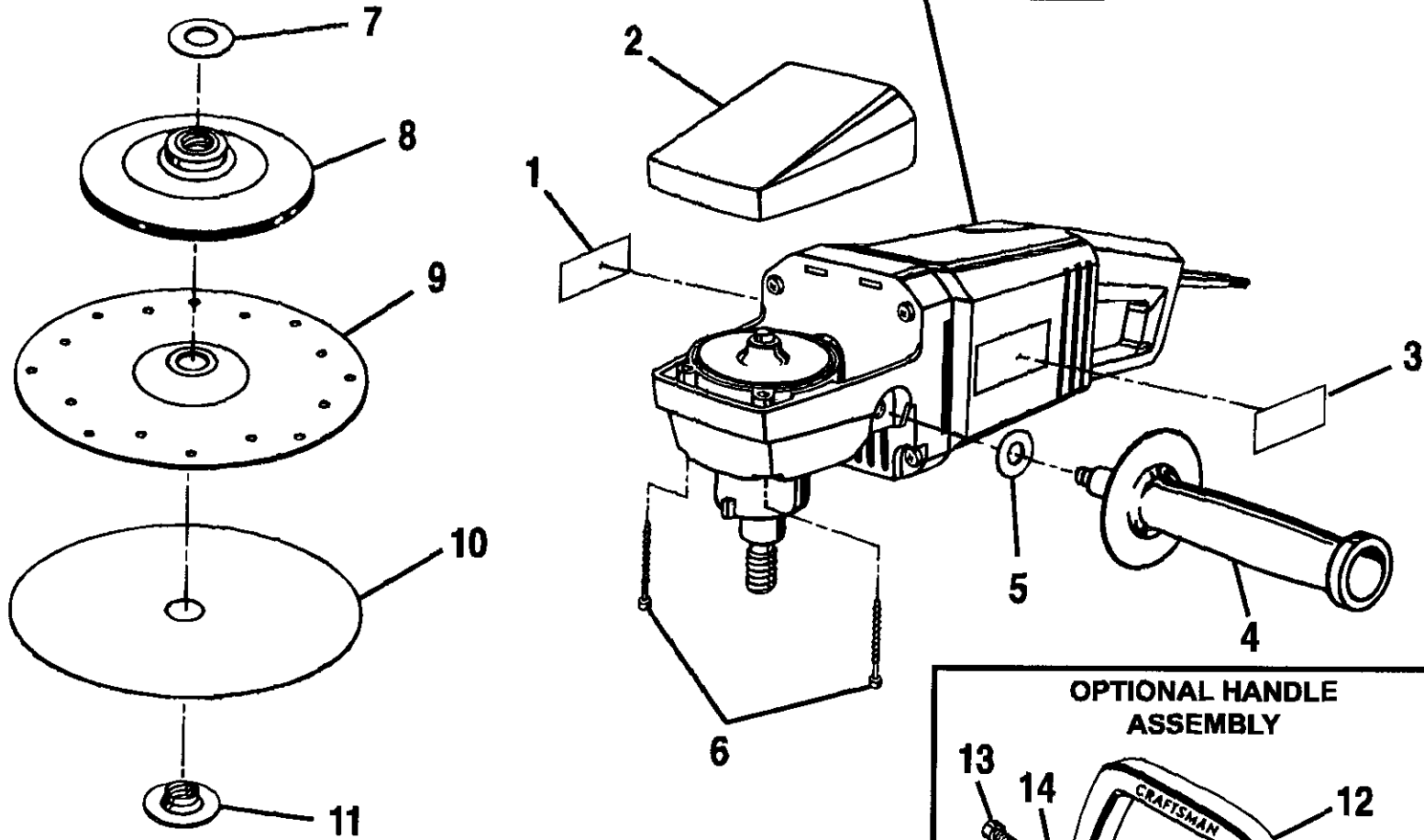

CRAFTSMAN DISC SANDER – MODEL NUMBER 315.115042

The model number will be found on a plate attached to the motor housing. Always mention the model number in all correspondence regarding your CRAFTSMAN DISC SANDER or when ordering repair parts.

PARTS LIST

KEY NO.	PART NUMBER	DESCRIPTION	QUAN.	KEY NO.	PART NUMBER	DESCRIPTION	QUAN.
1	982789-001	Data Plate	1	10	***	7 Inch Sanding Discs with 7/8 in. hole (Item Nos. 9-25299 Fine Grit, 9-25291 Medium Grit, and 9-25292 Coarse Grit)	1
2	998174-001	Gear Housing Cover	1	11	617294-001	Flange Nut	1
3	998182-001	Logo Plate	1	12	967862-000	Optional Handle Assembly (Includes Key Nos. 13 and 14)	1
4	972895-003	Auxillary Handle	1	13	967656-002	* Cap Screw (#3/8-24 x 1 in. Soc. Hd.)	2
5	621721-002	Washer	1	14	703776-035	Washer	2
6	989592-004	* Screw (#8-10 x 2 in. Fil. Hd.)	2		972000-897	Owner's Manual	
7	622141-013	Washer	1				
8	617291-001	Back-Up Pad	1				
9	622839-000	Back-Up Disc	1				

NOTE "A": The assembly shown represents an important part of the Double Insulated System. To avoid the possibility of alteration or damage to the system, service should be performed by your nearest Sears Repair Center. Contact your nearest Sears Retail Store for service center information.

* Standard Hardware Item — May Be Purchased Locally

** Available From Div. 98 — Source 980.00

Get it fixed, at your home or ours!

For repair of major brand appliances **in your own home...**
no matter who made it, no matter who sold it!

1-800-4-MY-HOMESM Anytime, day or night
(1-800-469-4663)

www.sears.com

To bring in products such as vacuums, lawn equipment and electronics
for repair, call for the location of your nearest **Sears Parts & Repair Center.**

1-800-488-1222 Anytime, day or night

www.sears.com

For the replacement parts, accessories and owner's manuals
that you need to do-it-yourself, call **Sears PartsDirectSM!**

1-800-366-PART 6 a.m. – 11 p.m. CST,
(1-800-366-7278) 7 days a week

www.sears.com/partsdirect

To purchase or inquire about a Sears Service Agreement:

1-800-827-6655

7 a.m. – 5 p.m. CST, Mon. – Sat.

Para pedir servicio de reparación a domicilio,
y para ordenar piezas con entrega a domicilio:

1-888-SU-HOGARSM
(1-888-784-6427)

Au Canada pour service en français:

1-877-LE-FOYERSM
(1-877-533-6937)

