

Owner's Manual

CRAFTSMAN®



42" HIGH SPEED LAWNSWEEPER

Model No's. 486.24266

DO NOT RETURN TO STORE
For Missing Parts or Assembly
Questions Call 1-866-576-8388

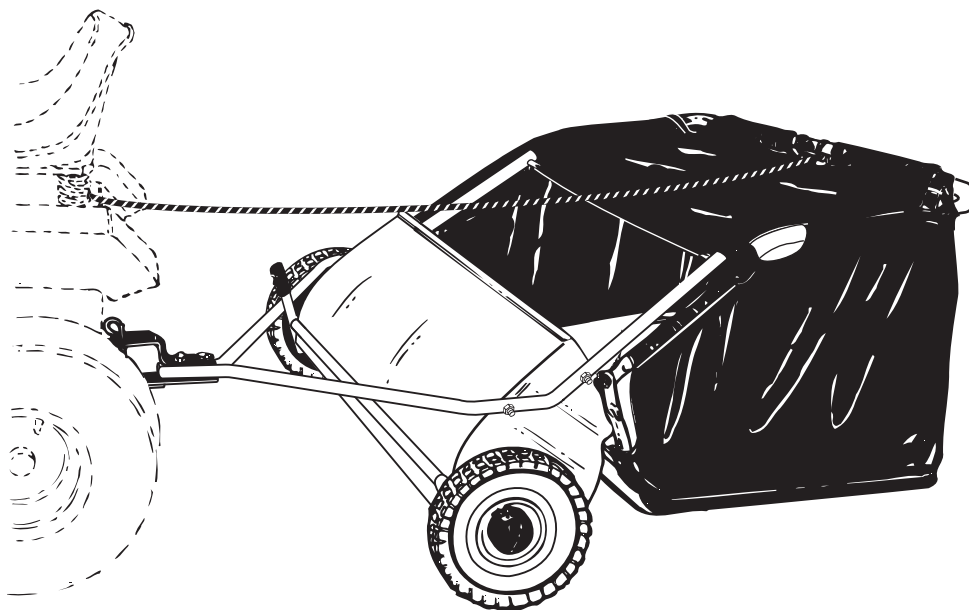

CAUTION:

Before using this product, read this manual and follow all Safety Rules and Operating Instructions.



Want more information
or assembly tips?
Scan for Video
Instruction Guide.

- Safety
- Assembly
- Operation
- Maintenance
- Parts

Sears Brand Management Corporation, Hoffman Estates, IL 60179 U.S.A.
www.craftsman.com

TABLE OF CONTENTS

Safety Rules	1	Maintenance Schedule	13
Warranty	2	Storage	13
Accessories and Attachments.....	3	Service and Adjustments	14
Carton Contents	3	Troubleshooting	14
Full Size Hardware Chart.....	4	Repair Parts Illustration	15
Sweeper Assembly Instructions.....	5	Repair Parts List	16
Hopper Assembly Instructions	7	Parts Ordering	BACK PAGE
Operation.....	12		

WARRANTY

CRAFTSMAN LIMITED WARRANTY

FOR ONE YEAR from the date of sale this product is warranted against defects in material or workmanship.

WITH PROOF OF SALE a defective product will be replaced free of charge.

For warranty coverage details to obtain free replacement, visit the web page: www.craftsman.com/warranty

To obtain warranty coverage, return a defective product with proof of sale to the retailer from which it was purchased for free replacement.

This warranty is void if this product is ever used while providing commercial services or if rented to another person.

This warranty gives you specific legal rights, and you may also have other rights which vary from state to state.

Sears Brands Management Corporation, Hoffman Estates, IL 60179

DO NOT RETURN TO STORE for Missing Parts or Assembly Questions

Call 1-866-576-8388 Attachment Hotline



SAFETY



Any power equipment can cause injury if operated improperly or if the user does not understand how to operate the equipment. Exercise caution at all times, when using power equipment.

1. Read the vehicle and sweeper owners manuals and know how to operate your vehicle and sweeper before using this sweeper attachment. Always instruct other users before they operate the sweeper.
2. Do not permit children to operate sweeper.
3. Do not permit anyone to ride on sweeper.
4. Never attach the hopper rope to any part of your body or clothing! Never hold onto the rope while towing the sweeper! Attach the rope to the towing vehicle to keep it away from wheels and rotating parts.
5. Operate the sweeper at reduced speed on rough terrain, near ditches and on hillsides to prevent loss of control.
6. Vehicle braking and stability may be affected with the attachment of this sweeper. Do not fill sweeper to maximum capacity without checking the capability of the towing vehicle to safely pull and stop with the sweeper attached. **Stay off of steep slopes.**
7. Stop and inspect vehicle and sweeper for damage after striking an object. Repair any damage before continuing operation.
8. Keep sweeper away from fire. Excessive heat can damage the brushes and hopper bag and could cause the bag and its contents to burn.
9. Before storing the sweeper, always empty the hopper bag to avoid spontaneous combustion.
10. Follow maintenance and lubrication instructions as outlined in the maintenance section of this manual.



Look for this symbol to point out important safety precautions. It means — **Attention!!**
Become alert!! Your safety is involved.

The model and serial numbers will be found on a decal attached to the lawnsweeper.

You should record both the serial number and the date of purchase and keep in a safe place for future reference.

MODEL NUMBER: 486.24266

SERIAL NUMBER: _____

DATE OF PURCHASE: _____

ACCESSORIES AND ATTACHMENTS

These accessories were available when the unit was purchased. They are also available at most Sears retail outlets and service centers. Most Sears stores can order repair parts for you when you provide the model numbers of your tractor and sweeper

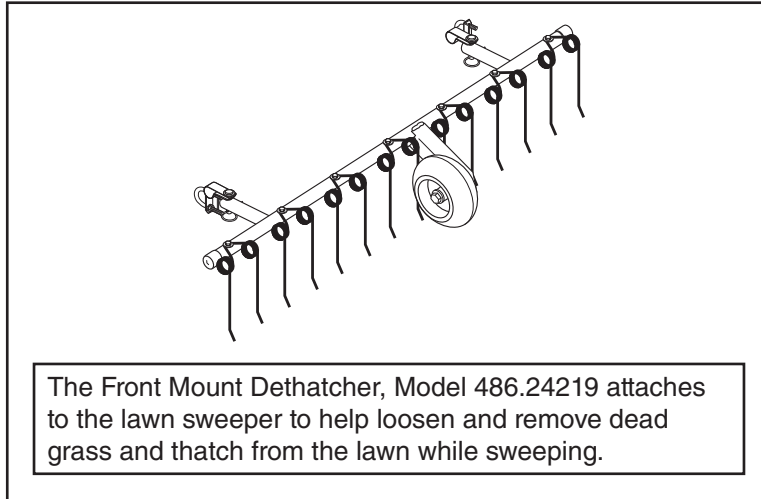

The Front Mount Dethatcher, Model 486.24219 attaches to the lawn sweeper to help loosen and remove dead grass and thatch from the lawn while sweeping.

CARTON CONTENTS

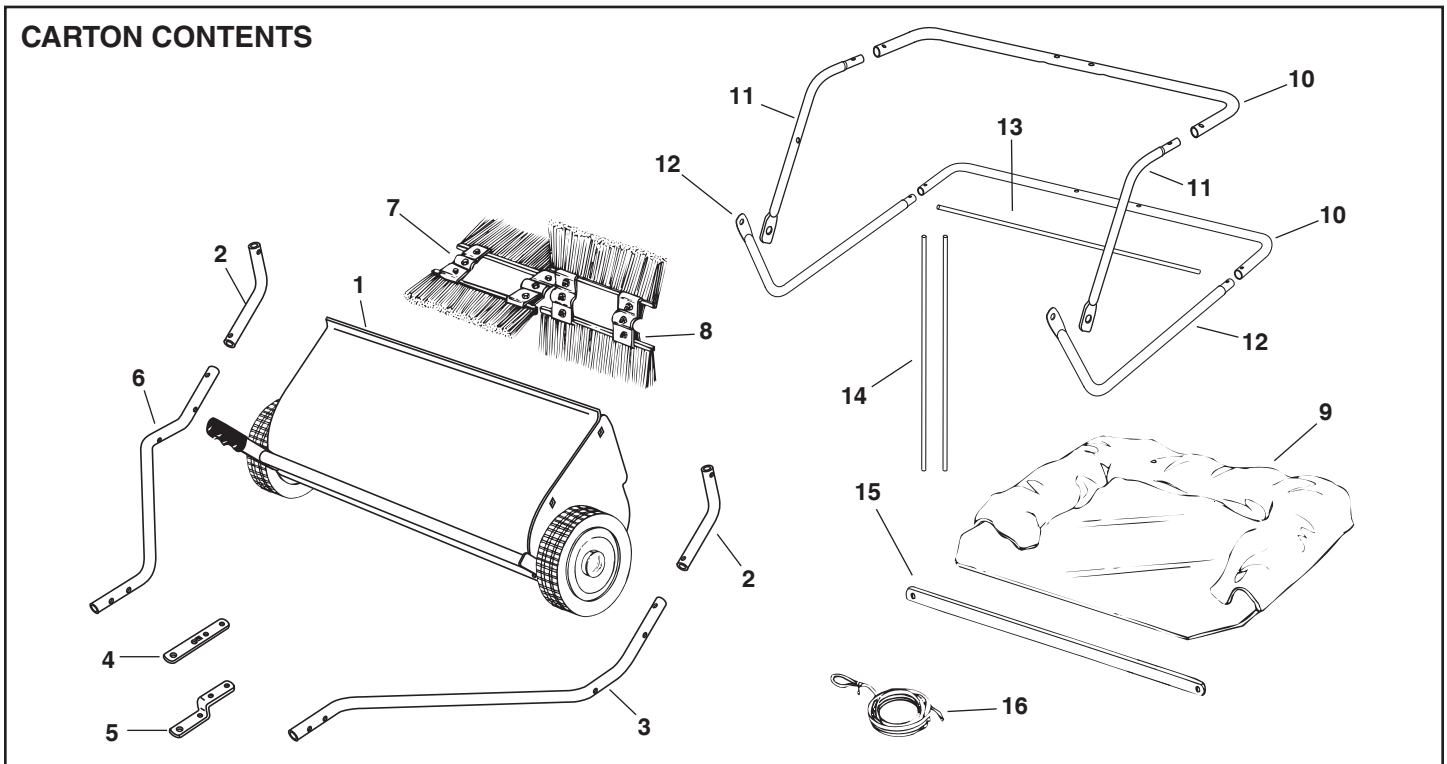

REF	PART NO.	QTY	DESCRIPTION	REF	PART NO.	QTY	DESCRIPTION
1	---	1	Sweeper Housing Assembly	9	49768	1	Hopper Bag
2	49766	2	Bag Arm Tube	10	47477	2	Rear Hopper Tube
3	46777		Hitch Tube, L.H. (Left Hand)	11	49765	2	Upper Hopper Tube
4	24192	1	Hitch Bracket	12	48726	2	Lower Hopper Tube
5	23687	1	Hitch Bracket, Bent	13	46823	1	Pivot Rod
6	46776	1	Hitch Tube, R.H. (Right Hand)	14	43938	2	Hopper Support Rod
7	---	1	Brush Assembly (Right Hand)	15	24189	1	Bag Frame Strap
8	---	1	Brush Assembly (Left Hand)	16	43737	1	Rope

HARDWARE PACKAGE CONTENTS

SHOWN FULL SIZE

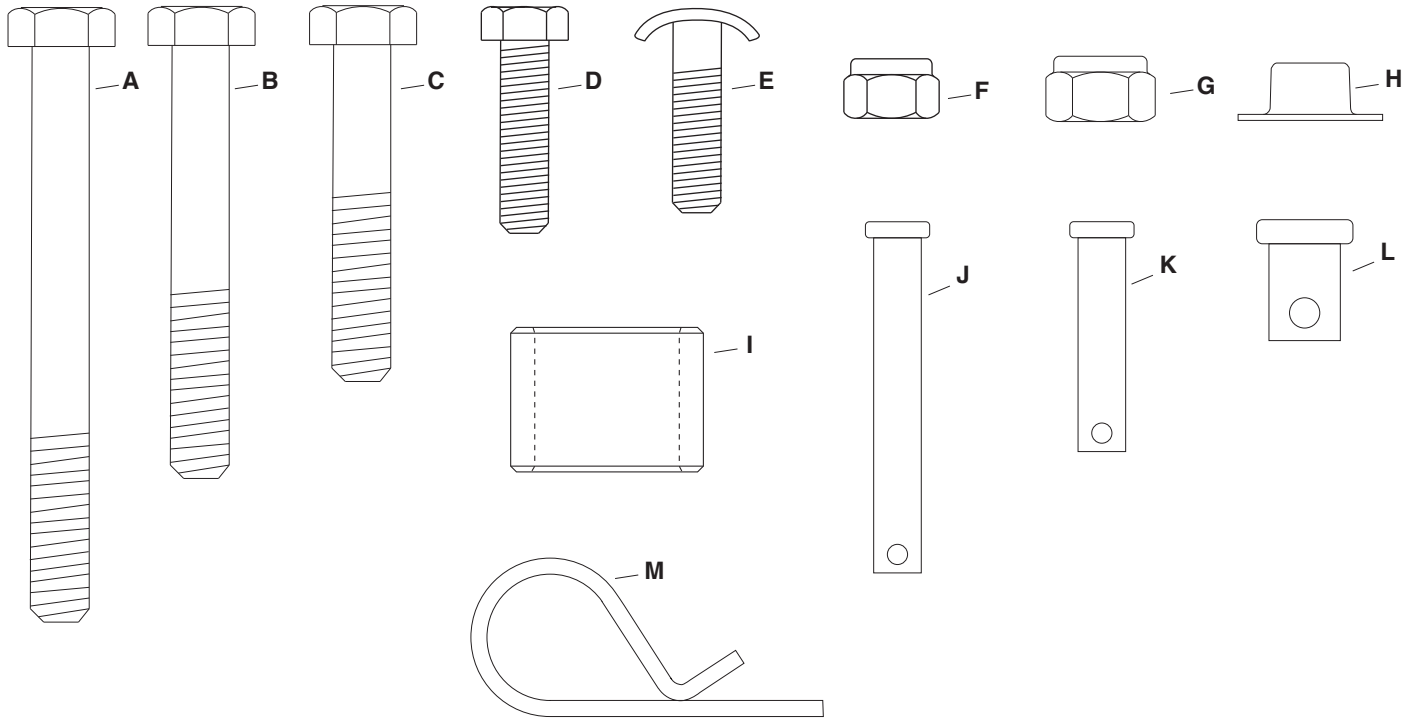

NOT SHOWN FULL SIZE

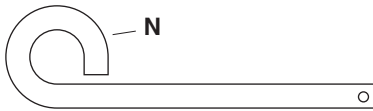

REF	PART NO.	QTY	DESCRIPTION	REF	PART NO.	QTY	DESCRIPTION
A	46782	2	Hex Bolt, 5/16-18 x 3" Lg.	I	23368	2	Hitch Spacer, 3/4"
B	43224	2	Hex Bolt, 5/16-18 x 2-1/4" Lg.	J	46867	2	Clevis Pin, 1/4" x 1-3/4"
C	43084	4	Hex Bolt, 5/16-18 x 1-3/4" Lg.	K	48365	2	Clevis Pin, 1/4" x 1-1/8"
D	43661	4	Hex Bolt, 1/4-20 x 1"	L	48366	2	Clevis Pin, 3/8" x 1/2"
E	43978	4	Curved Head Bolt, 1/4-20 x 1"	M	43055	7	Hairpin Cotter, 3/32"
F	47189	8	Nylock Nut, 1/4"	N	23353	1	Hitch Pin
G	47810	8	Nylock Nut, 5/16"	O	44481	2	Vinyl Cap
H	44917	2	Palnut, 3/8"				

ASSEMBLY

TOOLS REQUIRED FOR ASSEMBLY

- (1) Hammer
- (2) 7/16" Wrenches
- (2) 1/2" Wrenches

STEP 1 - REMOVE PARTS FROM CARTON

- To protect painted parts, lay them on cardboard or a mat.
- Remove the sweeper housing, the loose parts and the hardware package from the carton. Lay out the parts and hardware as shown on pages 3 and 4.
- Place the sheet of cardboard from inside the carton onto your work surface to prevent scratching the sweeper.

STEP 2: (SEE FIGURE 1)

- Each brush assembly has one brush retainer marked with either red or black ink. Lay out the brush assemblies as shown so that the brush retainers marked with ink are in the middle with the black one on your right and the red one on your left.

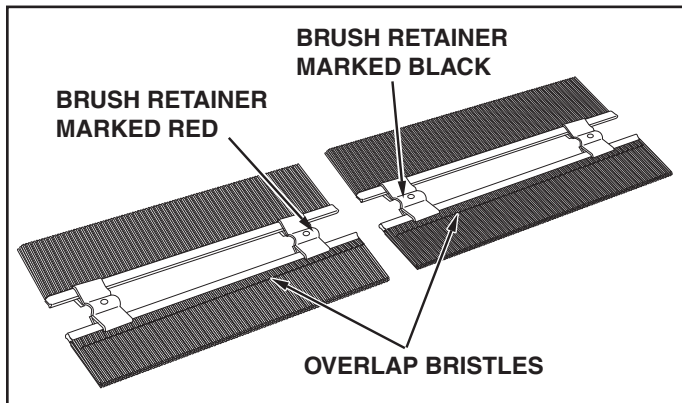

FIGURE 1

STEP 3: (SEE FIGURE 2)

- Tip the sweeper forward to access the brush shaft.

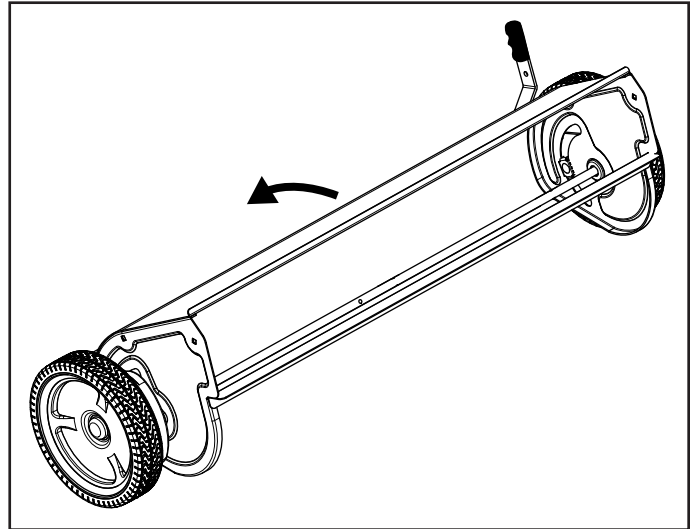

FIGURE 2

STEP 4: (SEE FIGURE 3)

IMPORTANT: Be sure the overlap bristles face out when a brush is rotated to the bottom position.

- Attach the brush assembly with the black brush retainer to the right end of the brush shaft using two hex bolts (D) and nylock nuts (F). The brush retainer marked with black ink must be placed to the **middle** of the sweeper.

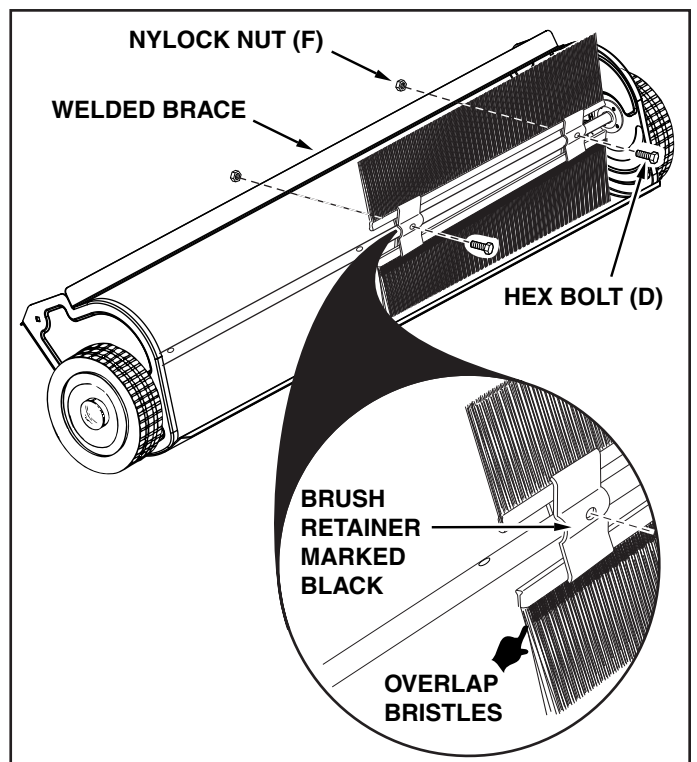

FIGURE 3

STEP 5: (SEE FIGURE 4)

- Attach the brush assembly with the red brush retainer to the left end of the brush shaft using two hex bolts (D) and nylock nuts (F). The brush retainer marked with red ink must be placed to the **middle** of the sweeper.
- Turn a wheel to rotate the brushes. (The wheels drive the brushes in one direction only.) The overlap bristles should be on the back side of the brush as it rotates.

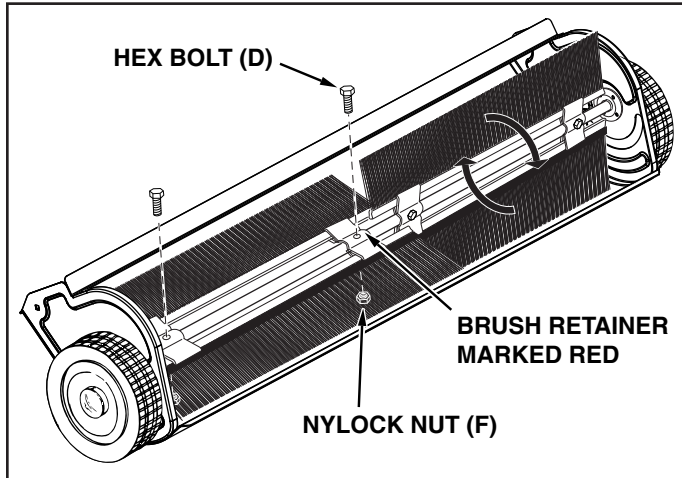

FIGURE 4

STEP 6: (SEE FIGURES 5 AND 6)

- The hitch tubes are stamped with a "77L" for the left tube and a "76R" for the right tube. The sweeper housing is marked with an "L" on the left with side and an "R" on the right side.
- Hold the left hitch tube against the left side of the sweeper so that the "77L" on the tube faces **away** from the sweeper. Attach the hitch tube using two hex bolts (C) and nylock nuts (G). **Do not tighten yet.**

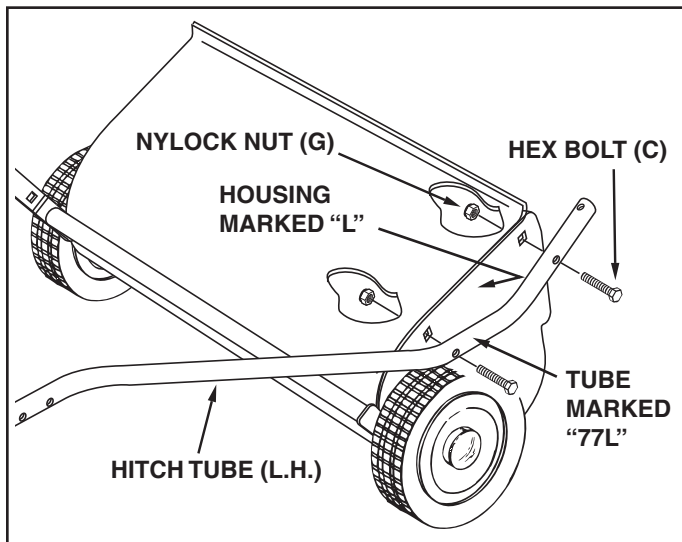

FIGURE 5

STEP 7: (SEE FIGURE 6)

- Hold the right hitch tube against the right side of the sweeper so that the "76R" on the tube faces **toward** the sweeper. Attach the hitch tube using two hex bolts (C) and nylock nuts (G). **Do not tighten yet.**

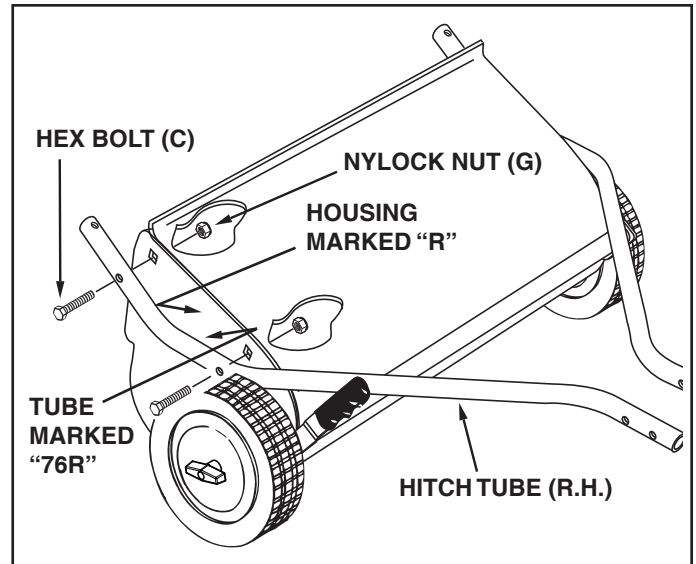

FIGURE 6

STEP 8: (SEE FIGURE 7)

- Fasten the hitch tubes together using two hex bolts (A) and nylock nuts (G). **Do not tighten yet.**

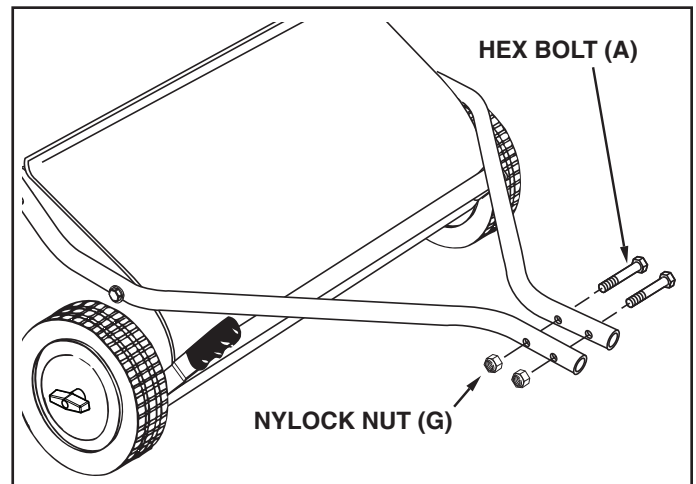

FIGURE 7

STEP 9

- Use the mark along the side of this page to measure the height of the tractor hitch. The mark is 10" from the bottom of the page. If the tractor hitch is less than 10" above the ground, go to **STEP 10a**. If the tractor hitch is 10" or more above the ground, go to **STEP 10b**.

STEP 10a: (SEE FIGURE 8)

- If the tractor hitch is less than 10" above the ground, assemble the hitch brackets as shown in figure 9. Insert two hex bolts (B) through the brackets, with the rear hex bolt between the cross bolts in the hitch tubes. Secure the hex bolts (B) with two nylock nuts (G). **Do not tighten yet.**
- Assemble the two spacers (I) onto the hitch pin (N) and secure the pin with the hairpin cotter (M).

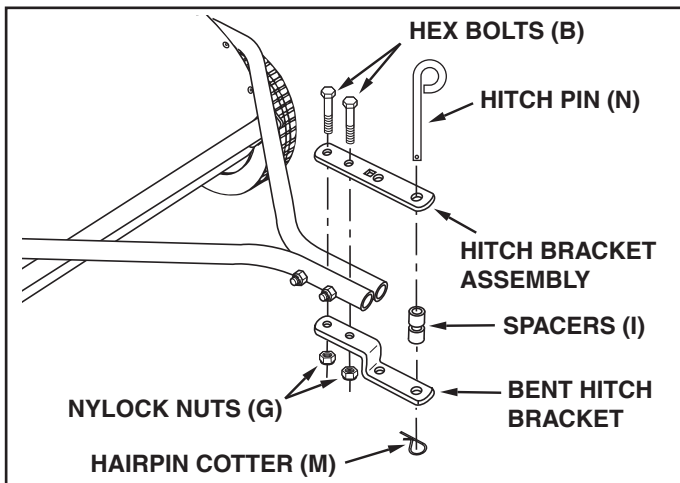

FIGURE 8

STEP 10b: (SEE FIGURE 9)

- If the tractor hitch is 10" or more above the ground, assemble the hitch brackets as shown in figure 10. Insert two hex bolts (B) through the brackets, with the rear hex bolt between the cross bolts in the hitch tubes. Secure the hex bolts (B) with two nylock nuts (G). **Do not tighten yet.**
- Assemble the two spacers (I) onto the hitch pin (N) and secure the pin with the hairpin cotter (M).

10"

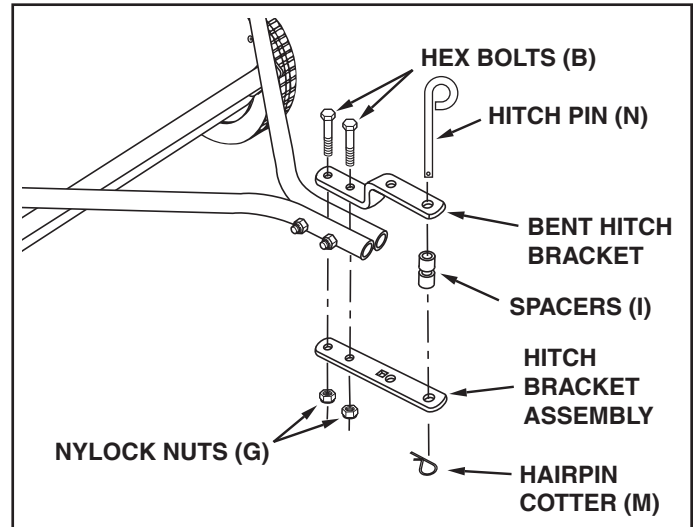

FIGURE 9

STEP 11

- **Tighten** the four bolts assembled in steps 6 and 7.
- **Tighten** the two bolts assembled in step 9.
- **Tighten** the two bolts assembled in step 10a or 10b.

ASSEMBLY OF HOPPER BAG

STEP 12: (SEE FIGURE 10)

- Fit the ends of the two upper hopper tubes into the ends of a rear hopper tube. Align the holes in the ends of the tubes and secure them in place using two curved head bolts (E) and nylock nuts (F).
- Fit the ends of the two lower hopper tubes into the ends of a rear hopper tube. Align the holes in the ends of the tubes and secure them in place using two curved head bolts (E) and nylock nuts (F).

NOTE: Either side of the rear hopper tube can face up.

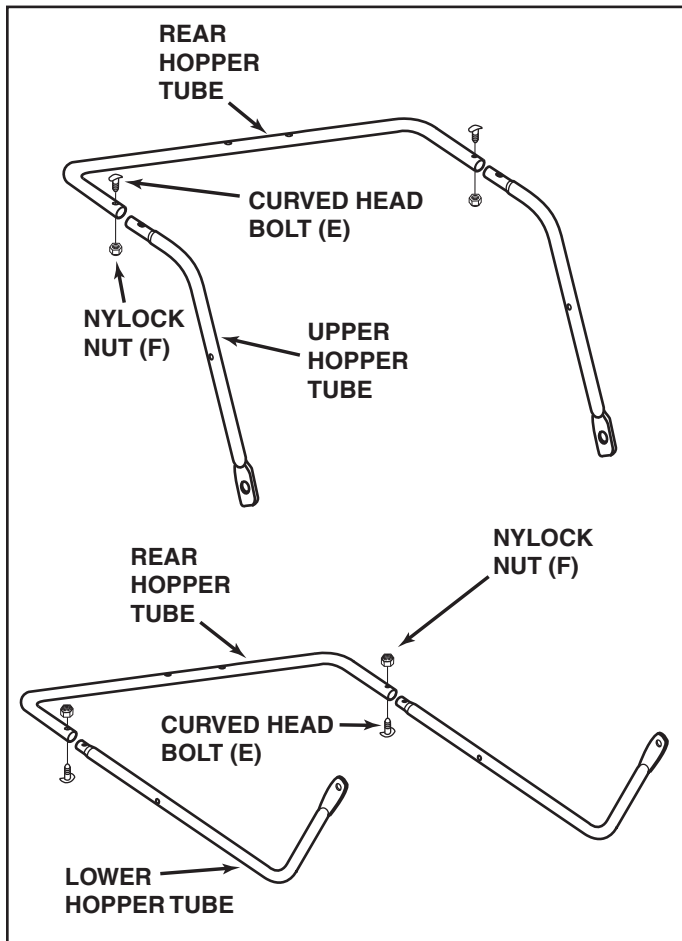

FIGURE 10

STEP 13: (SEE FIGURE 11)

- Unfold the hopper bag, reverse the fold of the mesh wind screen and then lay the bag out flat with the wind screen on top.
- Insert the ends of the assembled upper hopper tubes down through the stitched sleeves in the sides of the hopper bag and then slide the tubes back underneath the wind screen.

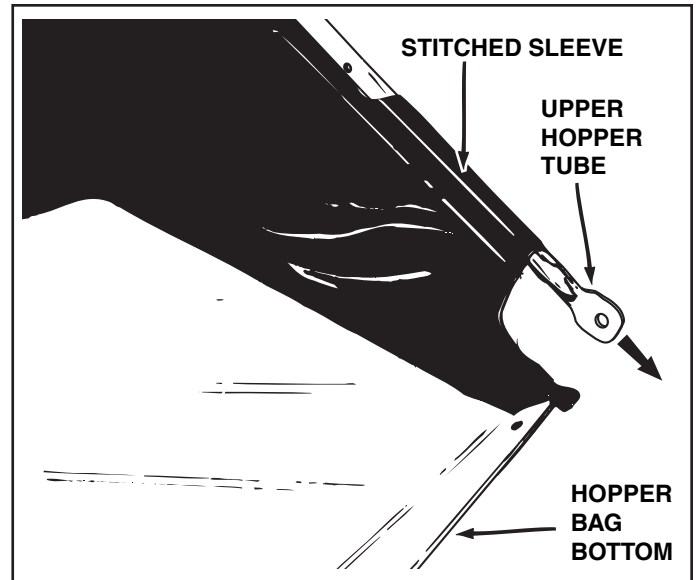

FIGURE 11

STEP 14: (SEE FIGURE 12)

- Place the assembled lower hopper tubes into the bottom of the hopper bag and then slide the tubes to the back of the bag.
- Attach the ends of the lower hopper tubes to the **inside** of the upper hopper tubes using two clevis pins (L) inserted from the inside, and two hair cotter pins (M).

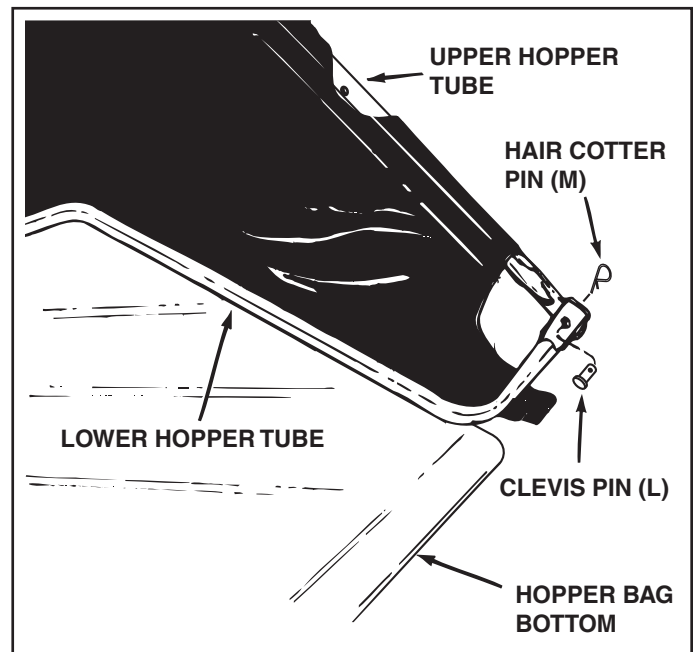

FIGURE 12

STEP 15: (SEE FIGURE 13)

- Insert the bag frame strap into the stitched sleeve at the front edge of the bag bottom.

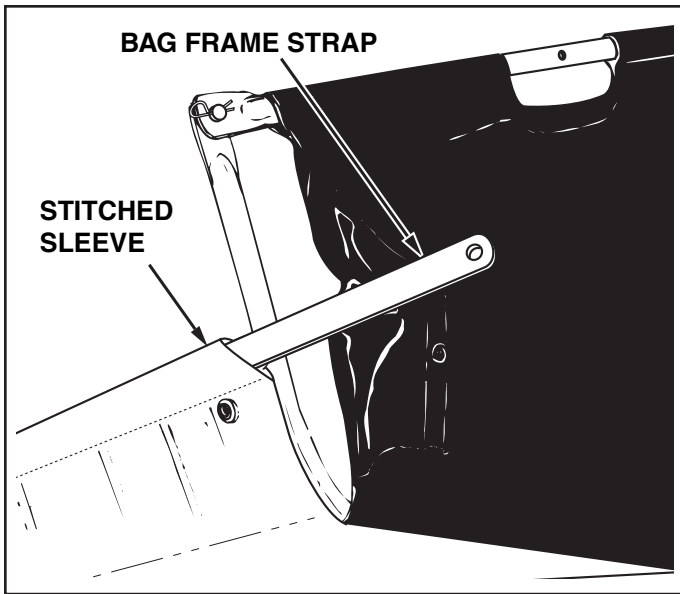

FIGURE 13

STEP 17: (SEE FIGURE 15)

- Fold the bag flaps around the lower hopper tubes and attach to the bag bottom using the snaps.

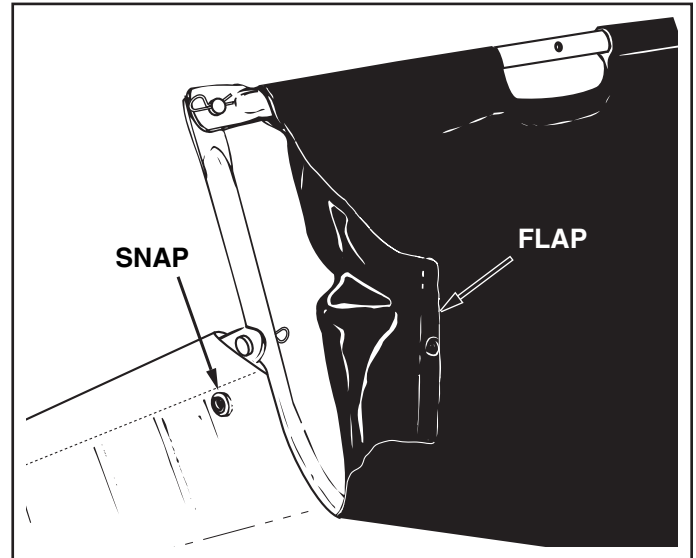

FIGURE 15

STEP 16: (SEE FIGURE 14)

- Assemble the bag frame strap to the holes in the lower hopper tubes using two clevis pins (K) and hair cotter pins (M).

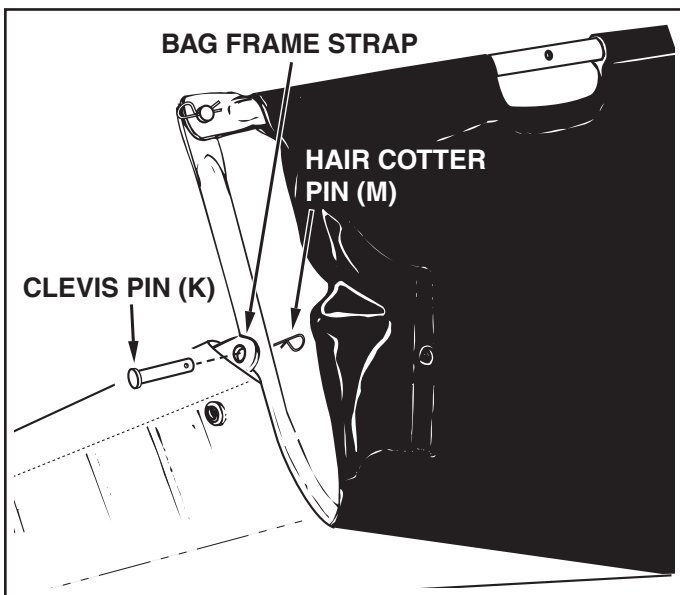

FIGURE 14

STEP 18: (FIGURE 16)

IMPORTANT: Do not over bend the support rods during the following step. Over bending will cause the steel rods to loose supporting tension.

- Tip the hopper onto it's back to assemble the two hopper support rods. Place the ends of each rod into the upper and lower rear hopper tubes, bending the rod just enough to fit into the holes in the tubes.

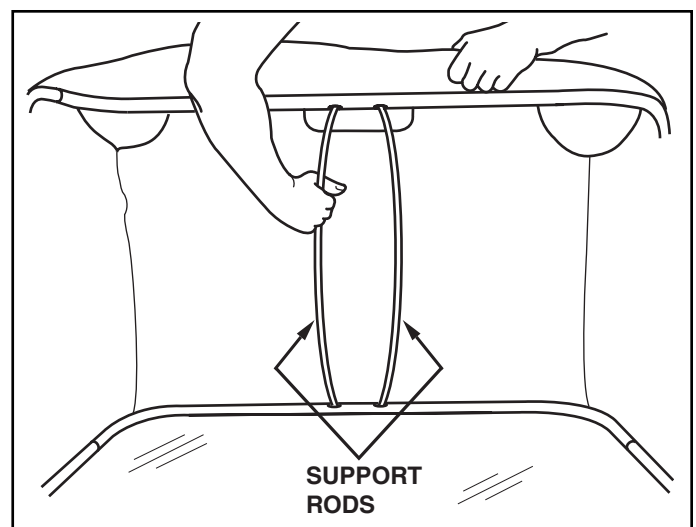

FIGURE 16

STEP 19: (SEE FIGURE 17)

- Slide the end of the pivot rod through the upper hopper tube. Place a bag arm tube onto the rod. Slide the rod through the stitched sleeve at the front edge of the wind screen, and then place another bag arm tube onto the rod. Slide the rod through the other upper hopper tube.

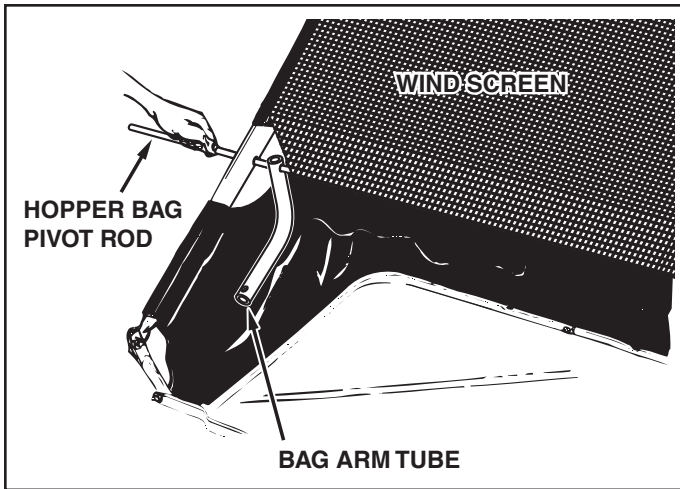

FIGURE 17

STEP 20: (SEE FIGURE 18)

- Assemble a vinyl cap (O) onto each bag arm tube.
- Assemble two palnuts (H) onto the ends of the pivot rod using a hammer.

HINT: To ease assembly of the palnuts, place the bag on its side on a solid surface. With the bottom end of the pivot rod against the surface, tap a palnut onto the top end of the rod. Repeat for other end of rod.

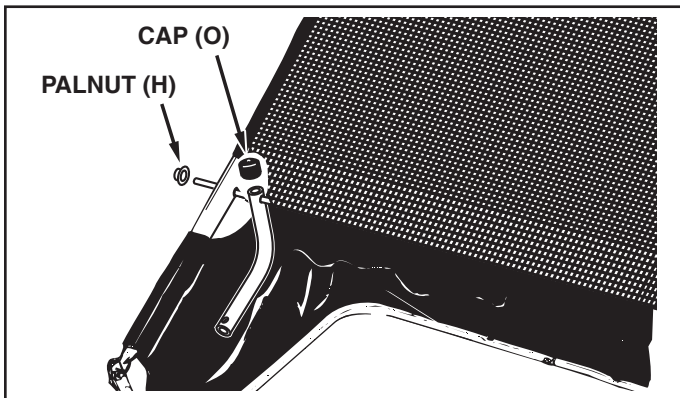

FIGURE 18

STEP 21: (SEE FIGURE 19)

- Secure the rope to the center of the upper rear hopper tube.



FIGURE 19

STEP 22: (SEE FIGURE 20)

- To attach the hopper bag to the sweeper, slide the ends of the bag arm tubes into the ends of the hitch tubes and secure with two clevis pins (J) and hairpin cotters (M).

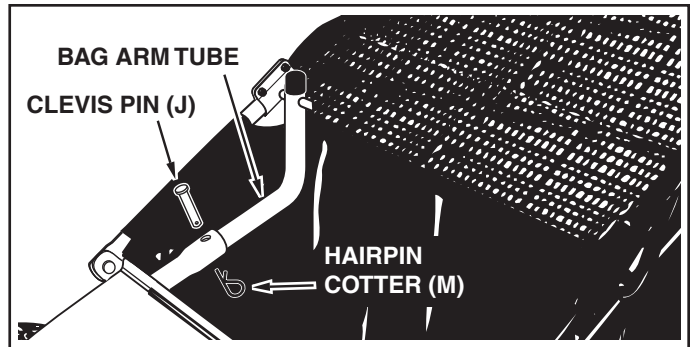

FIGURE 20

ATTACHING SWEEPER HITCH TO TRACTOR

- Place the tractor and sweeper on a flat level surface.
- Set the sweeper height adjustment handle to about the middle of its adjustment range.
- Attach the sweeper hitch to the tractor hitch, arranging the 3/4" spacers in one of six possible combinations as shown in GROUP A and GROUP B diagrams below.

IMPORTANT: To obtain the best performance from your sweeper, arrange the spacers so that the sweeper bag is approximately level with the ground and approximately 5" to 7" off the ground as shown in figure 21.

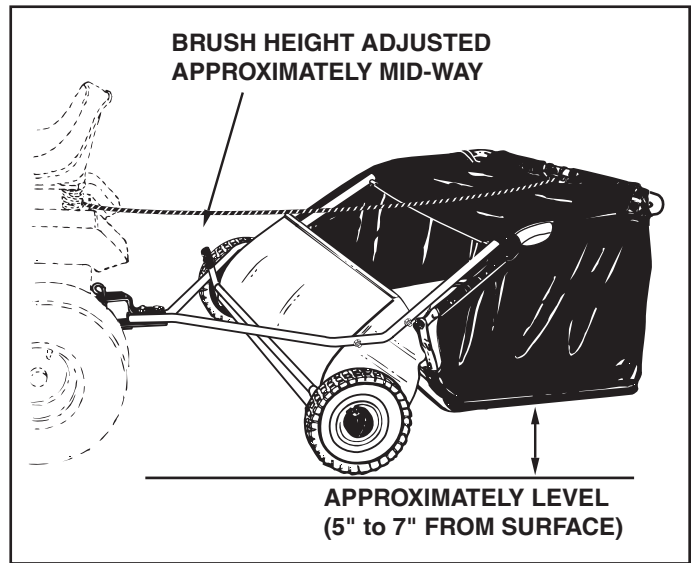
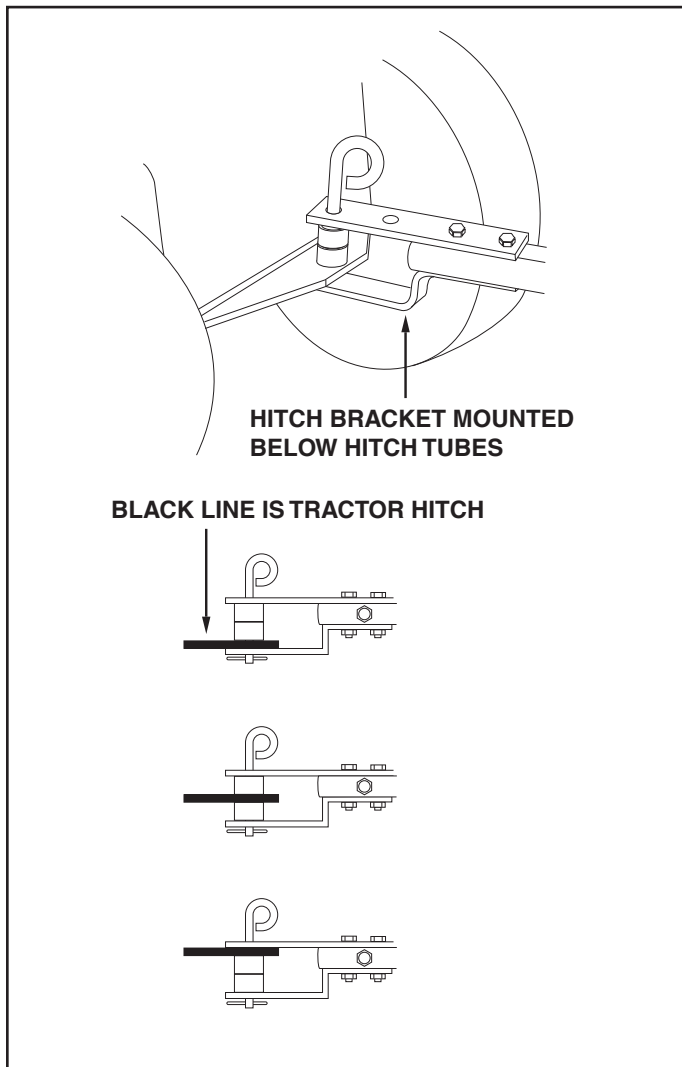
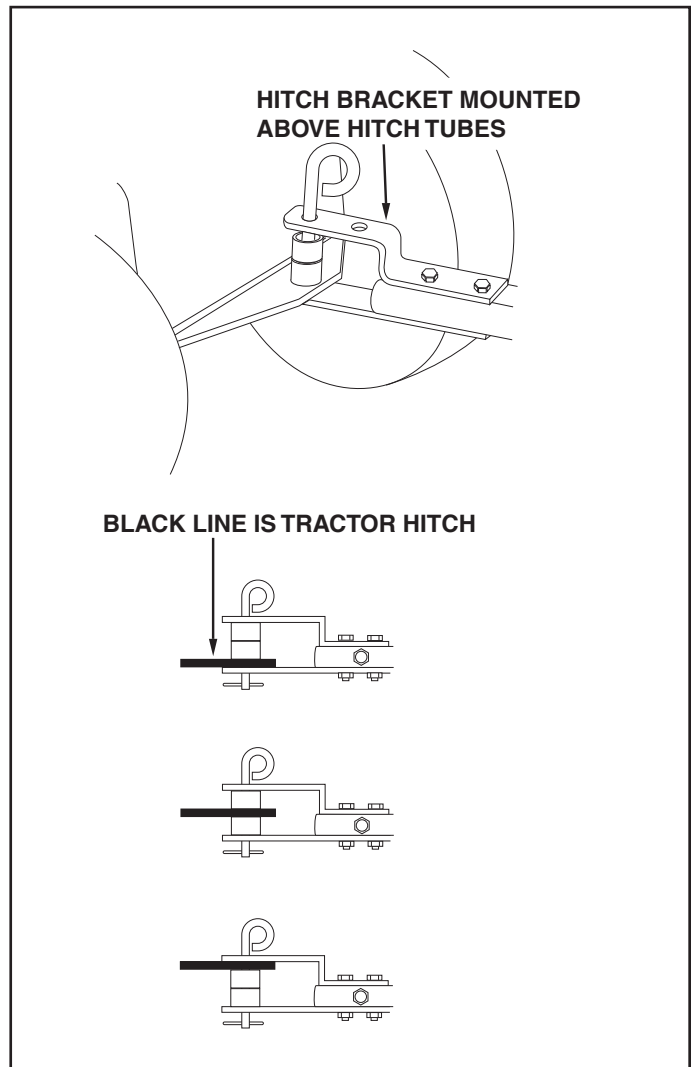

FIGURE 21

GROUP "A" - For vehicles with hitches having 8" to 10" ground clearance.



GROUP "B" - For vehicles with hitches having 10" to 13" ground clearance.



OPERATION

KNOW YOUR SWEEPER

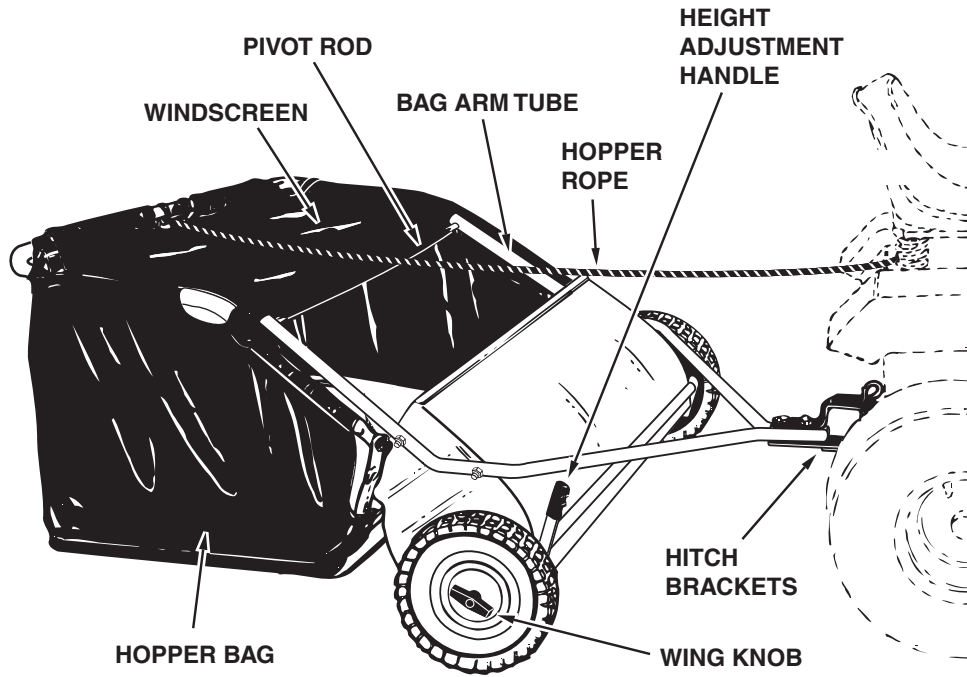

Hopper Bag	Collects grass clippings, leaves and debris.
Hopper Rope	Permits dumping of hopper bag from driver's seat.
Windscreen	Helps prevent collected material from being blown out of hopper bag.
Bag Arm Tubes	Connects the hopper bag to the sweeper housing.
Pivot Rod	Allows hopper bag to tilt forward to dump material.
Height Adjustment Handle	Adjusts the operating height of the sweeper.
Hitch Bracket	Connects the sweeper to the towing vehicle. Adjusts for various height tractor hitches.
Wing Knob	Tightens the wheel in position after adjusting height.



CAUTION: Maximum towing speed is 6 m.p.h.
Driving too fast may damage wheels and bearings.

HOW TO USE YOUR SWEEPER

BRUSH HEIGHT ADJUSTMENT

- To adjust your sweeper brushes to the best operating height, loosen the wing knob and push down on the height adjustment handle to raise the brush, or push up on the handle to lower the brush. Best adjustment is when the brush setting is 1/2" down into the grass. Always mow the grass to an even height before sweeping.

SWEEPING SPEED

- Do not exceed 6 m.p.h.** Try a starting speed of approximately 3 m.p.h. (third gear on most tractors). Depending on the conditions, it may be necessary to adjust the sweeping speed in order to achieve best results.

DUMPING OF SWEEPER

- Your sweeper can be dumped easily without getting off of the rider or tractor. Simply pull the rope forward to dump the hopper. Always empty hopper after each use.



CAUTION: Never attach the hopper rope to any part of your body or clothing! **Never hold onto** the rope while towing the sweeper! **Attach the rope** to the towing vehicle to keep it away from wheels and rotating parts.



CAUTION: Keep sweeper away from fire. Excessive heat can damage the brushes and hopper bag and could cause the bag and its contents to burn.

MAINTENANCE

CUSTOMER RESPONSIBILITIES

- Read and follow the maintenance schedule and the procedures listed in the maintenance section.

MAINTENANCE SCHEDULE Fill in dates as you complete regular service.	Service Dates											
	Before each use	After each use	Twice a year	Every year	Before storage							
Check for loose fasteners	X											
Check for worn or damaged parts	X			X								
Clean, inspect & lubricate wheel bearings				X								
Clean Sweeper		X			X							
Clean, inspect & lubricate gears				X								

SCHEDULED MAINTENANCE

- Clean the sweeper after each use.
- Inspect for worn or damaged parts, such as brushes and wheels.
- Every year, remove the wheels and clean the gear teeth and the teeth on the back side of the wheel. After cleaning, lubricate the axle, and the teeth on the gears and the wheel with a light coat of grease. To remove the right wheel, unscrew the wing knob and remove the wheel and washers. To remove the left wheel, pop off the hub cap using a screwdriver and remove wheel along with the bolt, washers, step spacer and nut. See figures 22 and 23.

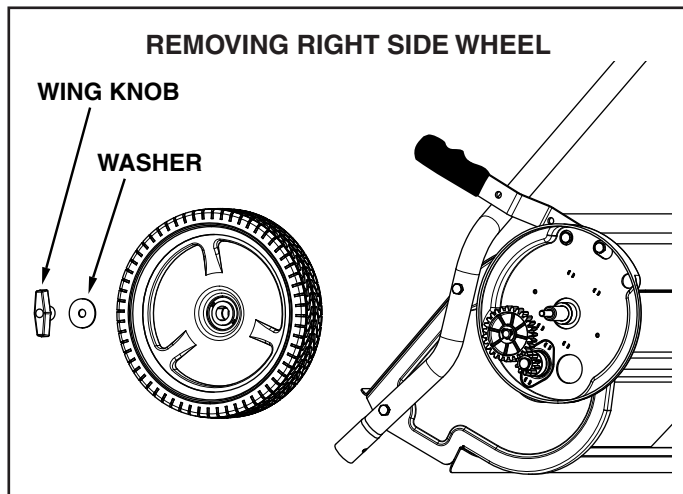

FIGURE 22

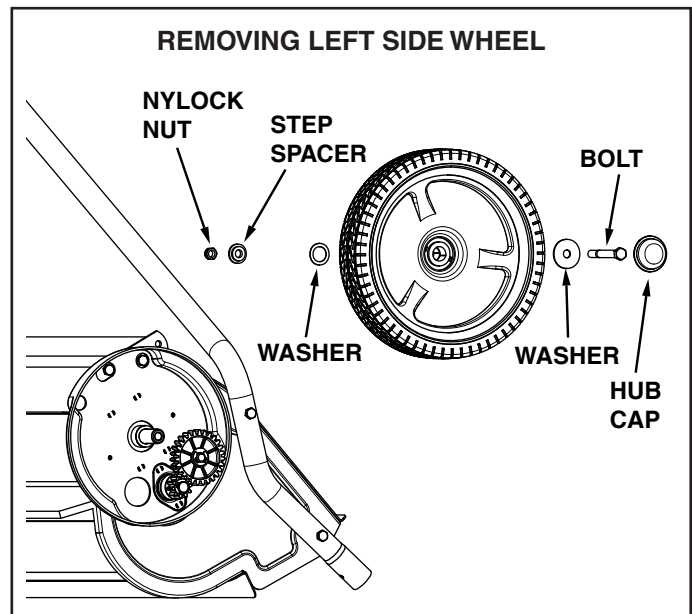

FIGURE 23

CLEANING

- Clean sweeper housing with a soft brush or cloth.
- Clean debris from hopper bag with a brush or broom.
- Remove any material which has wrapped around brushes or ends of brush shaft.

STORAGE



CAUTION: Before storing the sweeper, always empty the hopper bag to avoid spontaneous combustion.

- Clean the sweeper and hopper bag thoroughly to help prevent rust and mildew.
- To collapse the hopper bag for storage, remove the two hopper support rods from the rear of the hopper.
- Store in a dry area.

SERVICE AND ADJUSTMENTS

BRUSH REPLACEMENT

NOTE: Brush replacement should be done one brush at a time.

- Remove the hopper bag from the sweeper.
- Loosen the hex bolts and lock nuts on two single brush retainers which clamp one brush to the double brush retainers. **Do Not loosen** or remove the bolts which fasten the double brush retainers to the brush shaft. See figure 24.
- Slide the brush out of the retainers, noting on which side of the brush the bristles overlap. See figure 24.
- Install new brush, making sure the bristles overlap on the same side of the brush as before. See figure 24.

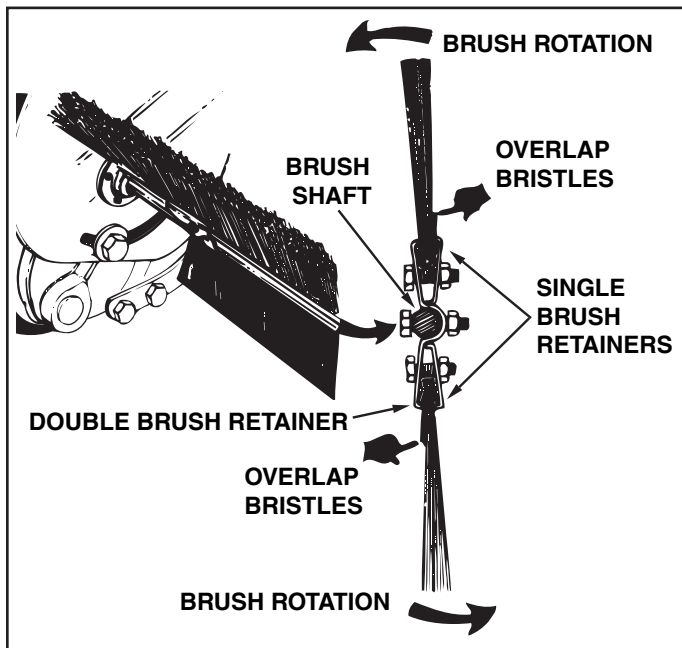

FIGURE 24

GEAR AND PAWL SERVICE

IMPORTANT: **Do not** remove both wheels at the same time to avoid mixing of parts. (The R.H. and L.H. pinion gears are not interchangeable.) **Make notes** on the position of washers and snap rings during disassembly.

- Remove one wheel at a time, following the instructions in the MAINTENANCE section.
- Remove the retaining rings which hold the gears on the brush shaft and the jack shaft.
- Remove the pinion gear, washer and drive pin from the end of the brush shaft. (The drive pin may fall out of the brush shaft when the pinion gear is removed.)
- Remove the idler gear and washers from the jack shaft.
- Clean all parts.
- Replace worn parts.
- To reassemble, lightly grease the jack shaft and the brush shaft. Insert the pin into the hole in the brush shaft. Make sure the pin stays in the shaft.
- Lightly grease the teeth on both gears and fill the recess of the pinion gear with grease. Assemble both gears back onto the shafts.
- Lightly grease the axle and then reassemble the wheel onto it. The brushes should rotate **only** during forward rotation of the wheel. If the brushes are driven (rotated) by both forward and reverse rotation of the wheel, the drive pin is jamming in the pinion gear. Disassemble and clean and lubricate the drive pin and pinion gear.

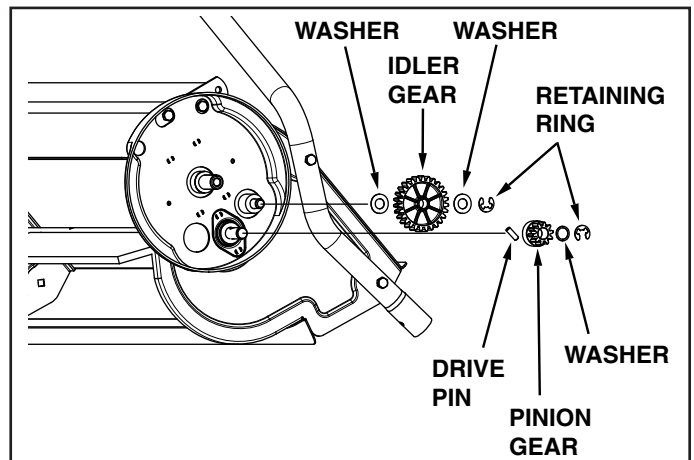

FIGURE 25

TROUBLESHOOTING

<p>Wheels skid when sweeping.</p>	<ul style="list-style-type: none"> • Brushes set too low. • Brushes are jammed • Wheels are jammed. 	<ul style="list-style-type: none"> • Adjust height till brushes are 1/2" down into grass. • Stop sweeper. Remove obstruction. • Remove one wheel at a time to check for obstruction or damage. Refer to Service and Adjustments section.
-----------------------------------	--	---

NOTES

REPAIR PARTS

486.24266 42" HIGH SPEED LAWSWEEPER

To order replacement parts, call Sears Parts Direct 1-800-252-1698 or go to www.searspartsdirect.com

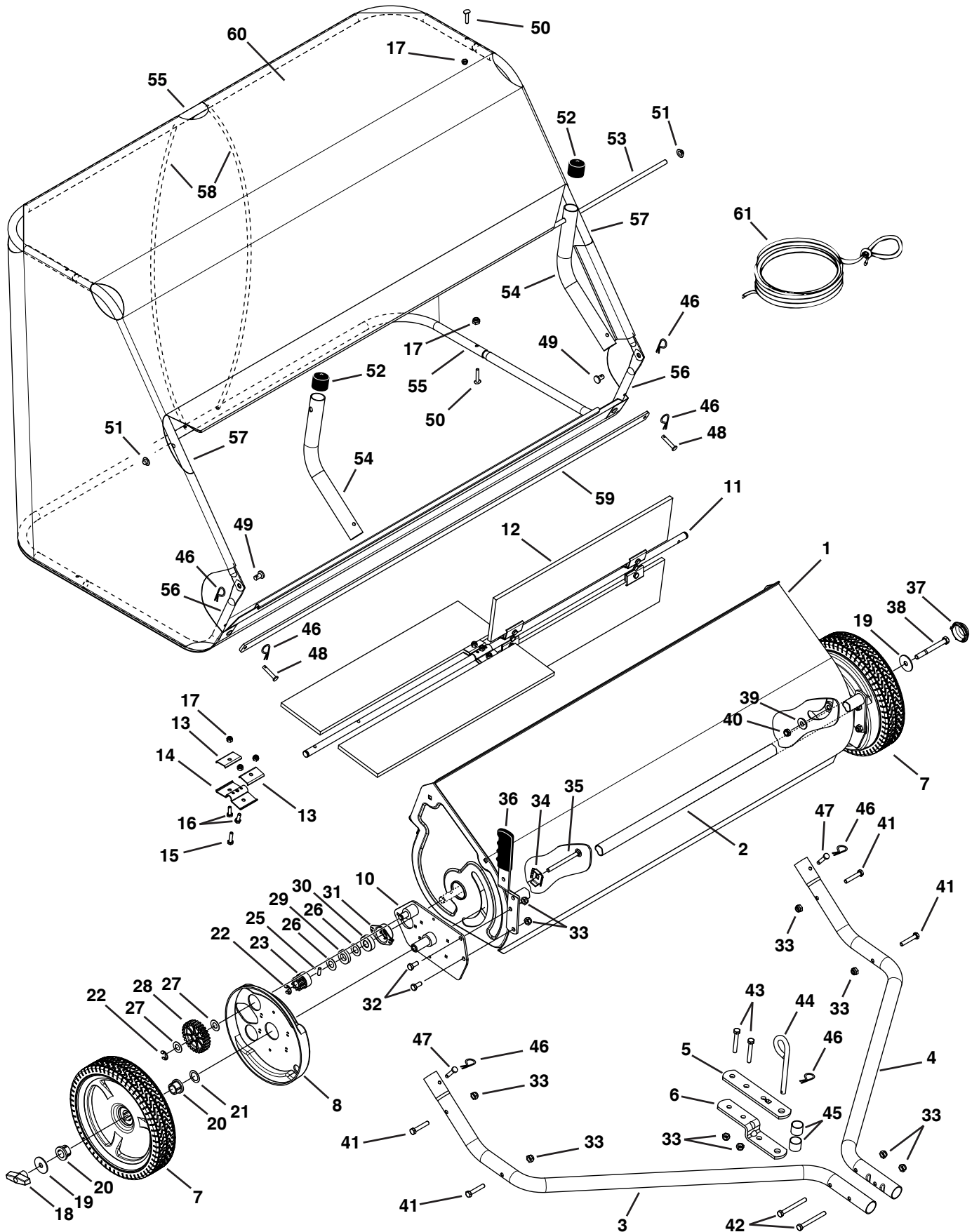

REPAIR PARTS

486.24266 42" HIGH SPEED LAWSWEEPER

To order replacement parts, call Sears Parts Direct 1-800-252-1698 or go to www.searspartsdirect.com

ITEM	PART NO.	QTY	DESCRIPTION	ITEM	PART NO.	QTY	DESCRIPTION
1	67105	1	Housing Assembly	32	43182	4	Bolt, Hex 5/16-18 x 3/4" Lg.
2	68202	1	Height Adjustment Tube Ass'y.	33	47810	12	Nut, Nylock 5/16-18 Thread
3	46776	1	Hitch Tube, R.H.	34	27234	1	Retainer, Carriage Bolt
4	46777	1	Hitch Tube, L.H.	35	42425	1	Bolt, Carriage 5/16-18 x 3-1/2"
5	24192	1	Bracket, Hitch (Straight)	36	43943	1	Grip, Height Adjust
6	23687	1	Bracket, Hitch	37	41017	1	Hub Cap
7	41436	2	Wheel & Tire Ass'y. (with bearings)	38	43932	1	Bolt, Hex 3/8-24 x 3-1/2" Lg.
8	41570	2	Dust Cover	39	26538	1	Spacer, Step
9	67103	1	Wheel Drive Assembly, L.H. (Not Shown)	40	1038	1	Nut, Nylock 3/8-24 Thread
10	67102	1	Wheel Drive Assembly, R.H.	41	43084	4	Bolt, Hex 5/16-18 x 1-3/4" Lg.
11	27235	1	Brush Shaft	42	46782	2	Bolt, Hex 5/16-18 x 3" Lg.
12	46780	4	Brush, 42"	43	43224	2	Bolt, Hex 5/16-18 x 2-1/4" Lg.
13	23581	8	Retainer, Brush (Single)	44	23353	1	Pin, Hitch
14	23580	4	Retainer, Brush (Double)	45	23368	2	Tube, Hitch Spacer
15	43661	4	Bolt, Hex 1/4-20 x 1" Lg.	46	43055	7	Hairpin Cotter, 3/32" #3
16	43012	8	Bolt, Hex 1/4-20 x 3/4" Lg.	47	46867	2	Pin, Clevis 1/4" x 1-1/2" Lg.
17	47189	16	Nut, Nylock 1/4-20 Thread	48	48365	2	Pin, Clevis 1/4" x 1-1/8"
18	43720	1	Wing Knob	49	48366	2	Pin, Clevis 3/8" x 1/2"
19	141	2	Washer, .378 x 1.25 x .061	50	43978	4	Curved Head Bolt, 1/4-20 x 1"
20	45088	4	Wheel Bearing	51	44917	2	Palnut, 3/8"
21	44008	2	Washer, 1-1/8" x .78" x .025"	52	44481	2	Cap, Vinyl
22	1650-1	4	Ring, Retaining (E-type)	53	46823	1	Pivot Rod, Hopper Bag
23	48652	1	Gear, Pinion R.H.	54	49766	2	Tube, Bag Arm
24	48651	1	Gear, Pinion L.H. (not shown)	55	47477	2	Tube, Rear Hopper Frame
25	47046	2	Dowel Pin (Drive)	56	48726	2	Tube, Lower Hopper Frame
26	R19212016	4	Washer, .656 x 1.25 x .025	57	49765	2	Tube, Upper Hopper Frame
27	44137	4	Washer, 1/2" x 1" x .02"	58	43938	2	Hopper Support Rod
28	41434	2	Idler Gear, 27 T.	59	24189	1	Strap, Bag Frame
29	23520	2	Spacer, .660 ID x .250 OD x .25	60	41751	1	Hopper Bag
30	44232	2	Ball Bearing	61	43737	1	Hopper Rope
31	41437	2	Bearing Retainer		41750	1	Owners Manual

CRAFTSMAN®

Product questions or problems?

1-888-331-4569

Customer Care Hot Line

**Get answers to questions, troubleshoot problems,
order parts, or schedule repair service.**

Para respuestas a preguntas o problemas, y ordenar
piezas o pedir servicio para la reparación de su equipo.

To help us help you, register your product at www.craftsman.com/registration

Para poderte ayudar mejor, registra tu producto en www.craftsman.com/registration

Join the Craftsman Club today!

CRAFTSMAN® CLUB

www.craftsman.com/signup

**Receive exclusive member benefits including special pricing and offers,
project sharing, expert advice, and SHOP YOUR WAY REWARDS!**

Como miembro exclusivo, recibe diversos beneficios como ofertas, precios especiales, proyectos nuevos, consejos de expertos y nuestro programa de puntos SHOP YOUR WAY REWARDS!