

ROUTER TABLE

for the Craftsman

Instruction Manual

Model Numbers: CRT/A
CRT/B
CRT/C
CRT/D
CRT/E
CRT/X

Trend Machinery & Cutting Tools Ltd.
Penfold Works Imperial Way Watford
Hertfordshire WD2 4YF England

Sales: _____ 01923 249911

Technical Enquiries: ____ 01923 224681

Fax: _____ 01923 236879

Email: _____ mailserver@trend.co.uk

WWW: ____ <http://www.trendm.co.uk>

Dear Customer

Thank you for purchasing the Trend Router Table for the Craftsman. We hope you enjoy many years of creative and productive use of this product.

Trend welcomes comments on this and all our products in our aim to develop and improve what we do to meet the needs of you, the customer.

Please contact our Technical Department in the first instance if you have any comments or queries.

Trend is the UK's leading supplier of router cutters, equipment and accessories. Our Craft Range of Cutters referred to in this manual, is designed specifically to meet the needs of amateur craftsmen and woodworking enthusiasts in quality and value.

For the professional woodworker, the Trend Professional Range of Routing Products has become the industry's standard guide to the most comprehensive range of router cutters and related products available in the UK.

Please contact your nearest Trend stockist to obtain any of our products and for a copy of the latest Trend Routing Catalogue.

CONTENTS _____ Page

Contents, Introduction, Tools Required _____	1
Safety Precautions, Specs, Cutter Care, Advice _____	3

Assembly Instructions

A. Assembly of Legs _____	5
B. Mounting Table to Workbench or Workboard _____	5
C. Mounting Table to a Workmate _____	5
D. Identification of Mounting Holes and Screws _____	8
E. Re-Drilling of Router Base _____	8
F. Re-Drilling of Insert Plate _____	9
G. Re-Drilling of Insert Plate and Router base _____	9
H. Fitting Insert Plate to Table Surface _____	10
I. Fitting Router to Insert Plate _____	10
J. Selecting & Fitting Insert Plate Rings _____	11
K. Fitting Lead-on Pin _____	11
L. Assembly & Mounting of Tenon Push Block _____	13
M. Assembly of Safety Dust Guard to Back Fence _____	13
N. Assembly of Back Fence _____	15
P. Attachment of Back Fence to Table _____	15
Q. Assembly & Alignment of Mitre Fence _____	17
R. Fitting of No-Volt Release Switch _____	17

Optional Accessories

S. Dust Extraction Equipment _____	18
T. Assembly of Spring Pressure Clamp _____	19
U. Assembly of Profiling Top Guard _____	20

Operation

V. Edging & Profiling using the Back Fence _____	21
W. Using Router Table for Grooving _____	22
X. Using Mitre Fence _____	22
Y. Using the Profiling Top Guard _____	24
Z. End Cutting with the Tenon Push Block _____	26
Spare Parts Diagram _____	28

Appendix

Plan for base of Hitachi TR12 _____	30
Plan for base of Ryobi R600, RE600 _____	31
Plan for base of Skil 1835U, 1875U1 _____	32
Plan for base of Elu MOF96(E) Mk1 and other similar makes _____	33
Plan for the Elu OF97(E) gasket _____	34
Plan for the Bosch POF52, 400A, 500A & 600 ACE gasket _____	35

INTRODUCTION

This Router Table is designed for the woodworking Craftsman and especially those new to the art of routing.

The Router Table has the necessary features to extend the versatility of most portable routers when profiling, edging, rebating and jointing.

The table includes the following features:

- A large machined aluminium Table Surface
- A Back Fence with Workpiece Support and Dust Extraction Point
- A clear Retractable Safety Dust Guard
- An adjustable sliding Mitre Fence
- A sliding Push Block for producing tenons
- A pre-drilled Insert Plate to fit most popular routers
- Insert Rings to reduce the 2 1/8" (54mm) cutter aperture
- A Lead-on pin for safer profiling with bearing guided cutters without a Back Fence
- No-Volt Release Switch - 230 volts
- Plastic Pushstick

The following Optional Extras are also available through your Trend stockist:

- Spring Pressure Clamps
- Safety Profiling Top Guard
- Extraction Hose and Adaptor

TOOLS REQUIRED FOR ASSEMBLY OF TABLE

A set of spanners and a screwdriver are required for the initial assembly of the table. Additional screws or nuts/ bolts will be required for mounting the table to a suitable surface.

Spanners 8mm, 10mm
and 11mm

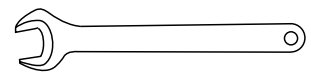

Screwdriver with flat head

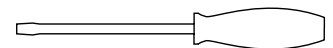

MOUNTING OF ROUTERS

Most popular makes of router can be mounted to the table, providing the correct model of table is purchased. Additional modification may be required for certain models of router and are described in sections E to G. Additional tools may be required to make these modifications.

Choice of router will depend on shank size of cutters that will be used. Higher powered routers will be required for using larger diameter cutters or for making heavier cuts. Additional plates can be purchased if more than one type of router is to be mounted to the table.

SAFETY PRECAUTIONS

1. Always switch off the power and unplug the router when changing cutters or when making adjustments.
2. Always wear protective goggles when routing.
3. Wear sound protective ear muffs when routing for long periods of time.
4. Do not wear loose clothing. Make sure baggy sleeves are rolled up and ties are removed.
5. Always remove spanners and allen keys from the table surface before switching router on .
6. Keep hands well clear of the router cutter when routing.
7. Avoid accidental starting of the router. Make sure the power switch is in the 'Off' position before plugging in and connecting to the electrical supply. Fit the no-volt release switch for ultimate safety.
8. Never leave the router unattended when running. Always wait until the router comes to a complete stop before making any adjustments.
9. Do not switch the router on with the cutter touching the workpiece.
10. Make a push stick and use it to move narrow workpieces across the cutting area.
11. Mount the Router Table securely to a work bench or to a workboard fitted to a suitable surface.
12. Check the function of the retractable safety guard before each use, to ensure it rides easily over the workpiece.
13. Always use the back fence to guide the work. Do not work freehand unless using bearing guided or pin guided cutters.
14. Always feed the workpiece against the rotation of the cutter
15. Periodically check all nuts and bolts to make sure they are tight and secure.
16. Use dust extraction equipment.

SPECIFICATIONS:

Table surface	359mm (14") x 610mm (24")
Table height	349mm (13 1/2")
Aperture opening	54mm (2 1/8")
Back Fence opening	73mm (2 7/8")
Height of Back Fence	100mm (4")

CUTTER CARE

1. Do not drop cutters or knock them against hard objects.
2. Cutters should be kept clean. Resin build-up should be removed at regular intervals with a wire brush. The use of a dry lubricant will act as a preventative eg Trendicote spray. Take care not to allow excessive quantities of lubricant to come into contact with the Router Table.
3. Cutter shanks should be inserted into the collet at least 3/4 of shank length to prevent distortion. A distorted collet should be discarded, as it can cause vibration and damage the shank.
4. Do not overtighten collet as this will score the shank and create a weakness there.
5. It is also advisable to periodically check the router collet nut for wear.

USEFUL ADVICE

1. Judge your feed rate by the sound of the motor. In time, the operator will acquire a 'feel' for the router, and a feed speed relative to the work will come naturally. Too slow a feed will result in burning.
2. Do not take too deep a cut in one pass. Take light cuts with many passes to maintain cutter speed and improve finish.
3. Apply the normal precautions as with any electric power tool.
4. The main abuse of routing machines is the inclination for operators to overload them. The motto is 'Keep the revs up'. The drop in revolutions should not exceed, if possible, more than 20% of full running speed.
5. The motor of a router is susceptible to the accumulation of sawdust and wood chips, and should be blown out, or 'vacuumed', frequently to prevent interference with normal motor ventilation.
6. Do not store the Router Table with router fitted on the floor, as chips, panel pins or dirt could drop into the air intake of the router.
7. Refer to the Instruction Manual supplied with your router for full details of it's features and safety information.
8. The use of a fine height adjuster is highly recommended (if available for your router) for accurately adjusting the height of the cutter.
9. Do not use strong detergents or organic solvents to clean the Router Table or any of its components.

Table Components

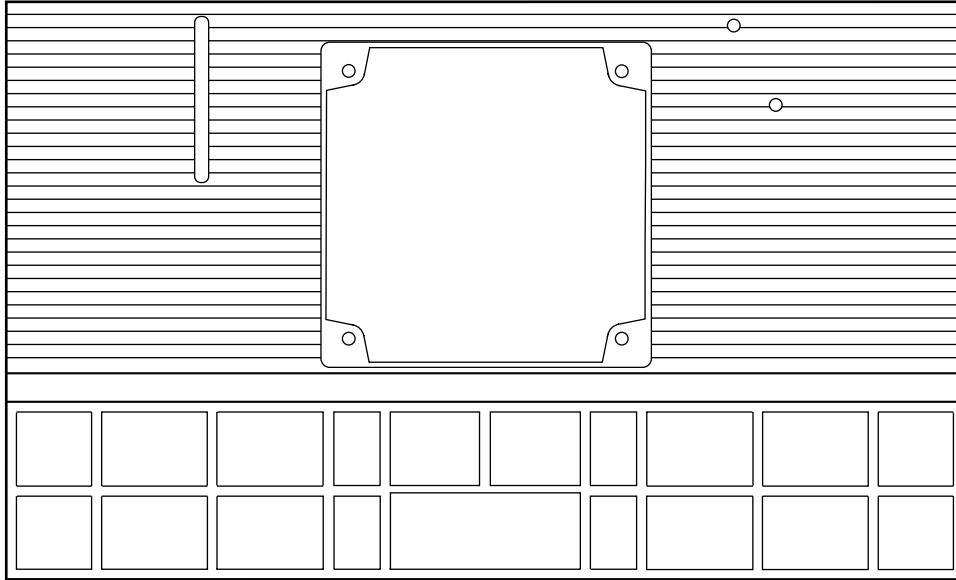

Table Surface
x 1

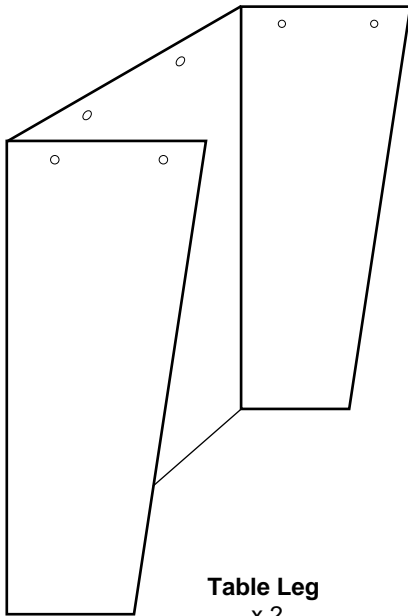

Table Leg
x 2



Nuts
x 12



Star Washers
x 12



Dome Headed Screws
x 12

ASSEMBLY INSTRUCTIONS

A. Assembly of Legs

1. Identify the components required, see opposite
2. Turn the **Table Surface** face down.
3. Locate one of the **Table Legs** at one end of the **Table Surface** as shown in figure A.
4. Insert the **Dome Headed Screws** through the six holes in the **Table Surface** and **Table Leg**. Six screws are required for each of the two **Table Legs**.
5. Lightly tighten the **Nuts** and **Star Washers** on to each **Dome Headed Screw**. The **Star Washers** should be against the inside of the **Table Leg**.
6. Repeat for the second **Table Leg**.
7. Turn the table assembly the correct way and tighten all 12 **Nuts** with a 10mm spanner (not provided).

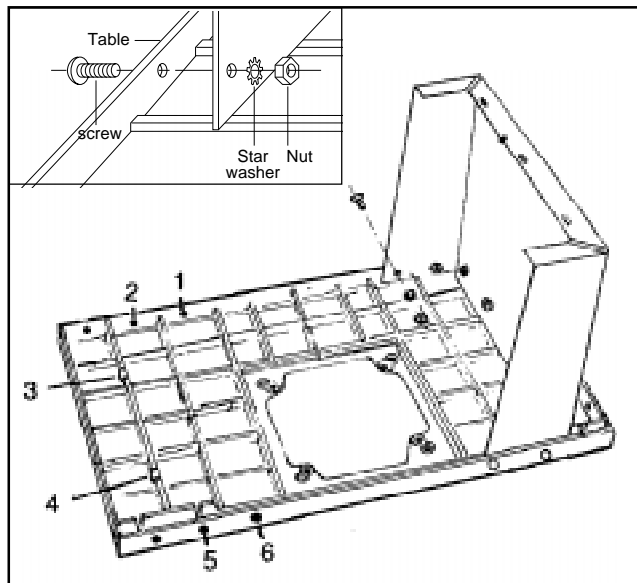

Fig. A

B. Mounting Table to Workbench or Workboard

The Router Table must always be mounted onto a suitable workbench or workboard for stability.

Each **Table Leg** has three slotted holes at the bottom mounting. Firmly secure the table assembly to a workbench or workboard, using appropriate bolts and wing nuts (not provided) as shown in fig. B. The slots are 6mm wide x 16mm long and will accommodate bolt sizes up to M6.

If a workboard is used, this will allow quick mounting and removal from a workbench by using G clamps.

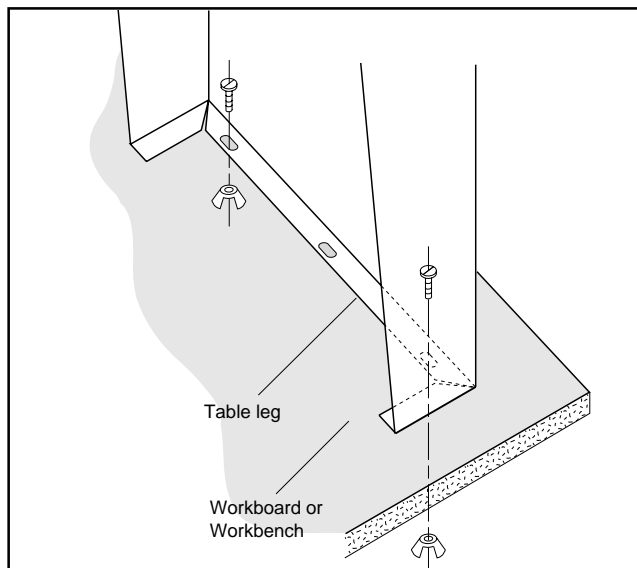

Fig. B

C. Mounting Table to a Workmate

The Router Table can also be fitted by using No. 12 self-tapping screws (not provided) through the centre holes in the legs to a 125mm (5") batten, which will enable the Router Table to be quickly mounted and removed from a Black & Decker Workmate[®] or similar workmate by simple clamping the batten between the jaws. See fig. C.

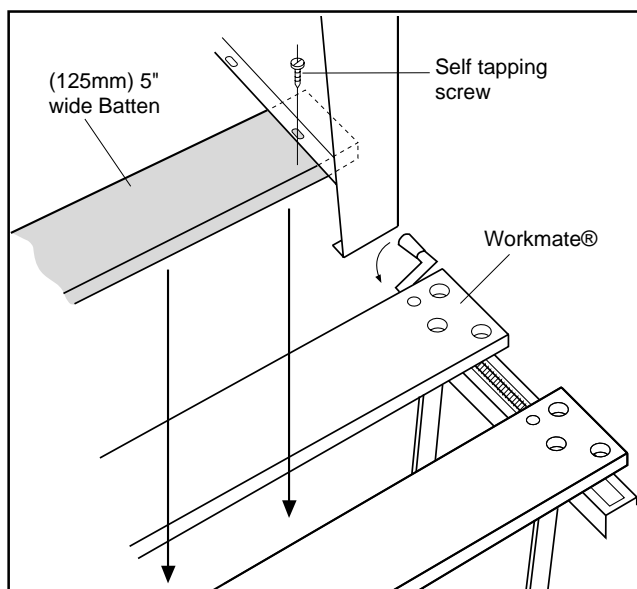
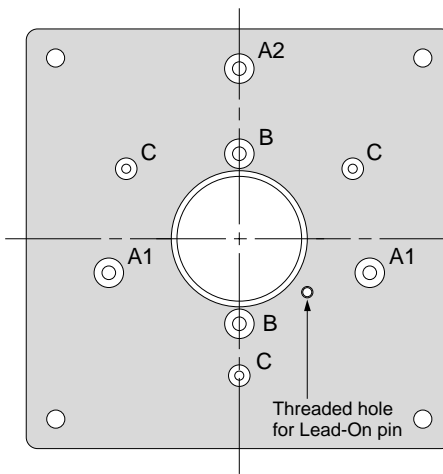











Fig. C

CRT/PLATE A (inc. Fixing Pack) supplied with Router Table CRT/A







Fixing Pack	
	M4 x 12mm (3)
	M6 x 10mm (2)
	M6 x 12mm (3)
	M6 x 25mm (3)
	M6 x 16mm (3)
	M6 x 35mm (3)
	Spring washer (3)
	M6 nut (3)
	3/4" x 1/4" Washer (3)

Router Models	Holes	Fixings
Following models will fit insert plate		
Elu MOF 69, 96(E) Mk 2	A1	M6 x 10
Elu OF97(E)♦	A1	M6 x 16
Elu MOF 131, 177(E)	A1, A2	M6 x 12
Bosch POF 52, 400, 500A, 600ACE♦	B	M6 x 12
Bosch GOF 1600A, 1700ACE	A1, A2	M6 x 12
Black & Decker BD780(E), KW780(E)	C	M4 x 12
Dewalt DW613	A1	M6 x 10
Require re-drilling of router base, see Section E		
Elu MOF 96(E) Mk 1*	B	M6 x 25▲
Black & Decker SR100*	B	M6 x 25▲
AEG OFS450S, OFS50, OFS720 & OFSE850*	B	M6 x 25▲
Metabo OF1028♦, OFE1229♦	A1	M6 x 35▲
Perles OF808, Stayer PR50*	B	M6 x 25▲
Ryobi R500♦, R502♦	A1	M6 x 35▲
Kango R8550S, Holzher 2335, 2355	B	M6 x 25▲
Virutex FR77C, 78C	B	M6 x 35▲

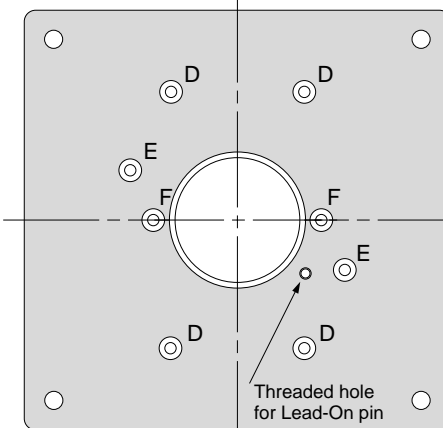
* see page 33

CRT/PLATE B (inc. Fixing Pack) supplied with Router Table CRT/B









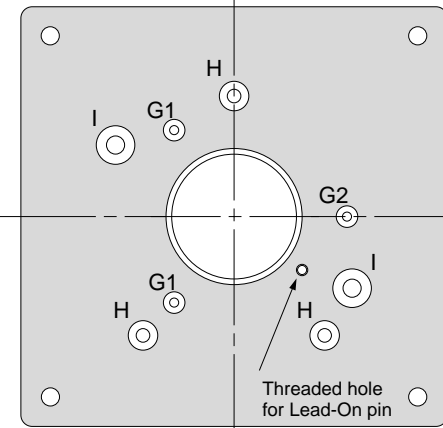

Fixing Pack	
	M4 x 12mm (4)
	M5 x 10mm (4)
	M5 x 16mm (2)

Router Models	Holes	Fixings
Following models will fit insert plate		
Hitachi M8♦, M8V♦	D	M5 x 10
Peugeot DF55E, DEF570E	E	M5 x 16
Ryobi RE120, R150, R151	E	M5 x 16
Makita 3620	F	M5 x 16
Require re-drilling of insert plate, see Section F		
Hitachi TR12♦ (see page 30)	-	M5 x 10
Ryobi R600♦, RE600♦ (see page 31)	-	M4 x 12 M5 x 16

CRT/PLATE C (inc. Fixing Pack) supplied with Router Table CRT/C





Fixing Pack	
	M4 x 12mm (2)
	M4 x 20mm (1)
	M6 x 25mm (3)
	M8 x 20mm (2)
	Spring washer (3)
	M6 nut (3)
	3/4" x 1/4" Packing Washer (9)
	6mm Washer (3)

Router Models	Holes	Fixings
Following models will fit insert plate		
Black & Decker BD66♦	G1 G2	M4 x 12 M4 x 20
Bosch GOF 900A, 900ACE	H	M6 x 35■
Ryobi RE600N♦, R600N♦	I	M8 x 20

- ♦ Remove plastic base of router before fitting router to insert plate
- ▲ Requires fitting of washer, spring washer and nut
- Requires user made packing piece/gasket, please see end of section D.4.(i) on page 8
- Requires fitting of washer, spring washer, nut and three 3/4"x1/4" packing washers which are placed between plate and router base for each fixing

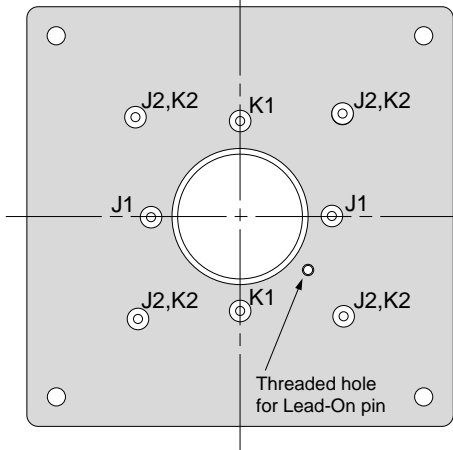
CRT/PLATE D (inc. Fixing Pack) supplied with Router Table CRT/D





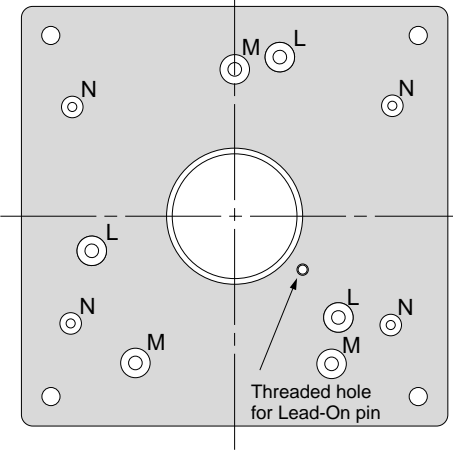

Fixing Pack	
	M4 x 12mm (4)
	M5 x 16mm (2)

Router Models	Holes	Fixings
Following models will fit insert plate		
Makita 3612BR	J1 J2	M5 x 16 M4 x 12
Makita 3612, Makita 3612C	K1 K2	M5 x 16 M4 x 12

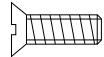
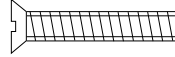
CRT/PLATE E (inc. Fixing Pack) supplied with Router Table CRT/E





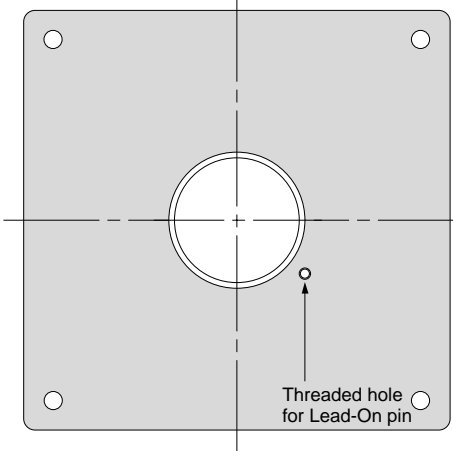

Fixing Pack	
	M5 x 10mm (4)
	M6 x 12mm (3)
	M6 x 35mm (3)
	Spring washer (3)
	3/4"x1/4" Packing Washer (9)
	M6 nut (3)
	6mm Washer (3)

Router Models	Holes	Fixings
Following models will fit insert plate		
AEG OFSE2000	L	M6 x 25
Bosch GOF1300ACE	M	M6 x 35 ■
Freud FT2000(E)	L	M6 x 12
Hitachi M12V/M12SA	N	M5 x 10

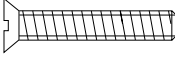
CRT/PLATE X (inc. Fixing Pack) supplied with Router Table CRT/X



Fixing Pack	
	M6 x 12mm (3)
	M6 x 35mm (3)
	No.10-32UNF x 3/8" (3)
	Spring washer (3)
	3/4"x1/4" Washer (3)
	M6 nut (3)

Router Models	Holes	Fixings
Require re-drilling of insert plate, see Section F		
Skil 1835, 1875UI - see p.32	-	No.10 - 32 UNF x 3/8"
Festo OF900(E), OF2000(E)	-	M6 x 35▲
Hitachi FM8, ZK2008	-	M6 x 35▲

- ◆ Remove plastic base of router before fitting router to insert plate
- ▲ Requires fitting of washer, spring washer and nut
- Requires user made packing piece/gasket, please see end of section D on page 8
- Requires fitting of washer, spring washer, nut and three 3/4"x1/4" packing washers which are placed between plate and router base for each fixing

D. Identification of Mounting Holes and Screws

See previous page to:

1. Identify which **Insert Plate** has been supplied with your Router Table.
2. Identify the mounting holes and fixing screws (including washers & nuts if applicable) which will be required to suit your router.
3. Identify whether your router or the **Insert Plate** requires re-drilling.

If at this point, you realise you have ordered the incorrect model of Router Table for your router, an exchange of the **Insert Plate** can be made direct with Trend, see address on front cover. Ensure that the fixing pack, insert rings and insert plate are returned. Please quote part number of plate required in the exchange.

Additional **Insert Plates** can be purchased through your nearest Trend stockist if you wish to fit other models of router to your router table. See previous page for selection, and spare parts diagram for price details.

Your Router should fall into one of the following categories:

- (i) No adjustment necessary - Proceed to section H. Please note for Elu OF97(E) see section (i) below. For Bosch POF 52, 400A, 500A and 600ACE see section D4 (ii) and for Bosch GOF900A and 1300ACE see section D4 (iii).
 - (ii) Router base requires re-drilling - Proceed to section E
 - (iii) **Insert Plate** requires re-drilling - Proceed to section F
- 4.(i) For the Elu OF97(E) a 6.35mm (1/4") thick MDF or plywood gasket is required. The central hole should be drilled out to 60mm in diameter and with two further holes of 8mm diameter and at 115mm centres. Please see page 34 for plan.

- (ii) For the Bosch POF DIY range of DIY routers a special gasket must be made in 3mm to 6mm thick plywood or MDF made. Please see page 35 for plan. This gasket is then placed between the underside of the plate in the table and the underside of the router

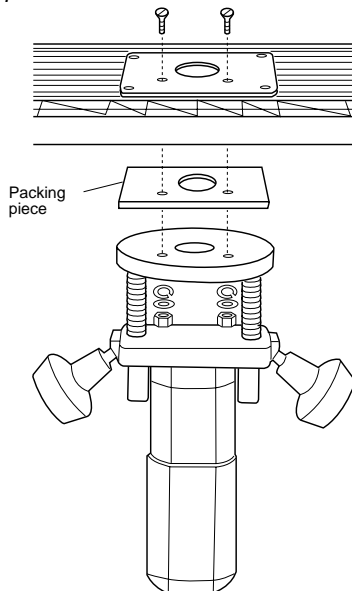

base. The fixing screws can then be used to secure. The use of a gasket serves two purposes, firstly it allows for secure fixing of the router, and secondly, due to the small aperture in the router it allows the tabs of the insert rings to fit tightly to the plate. Enlarging the aperture in the base of the router is also advised if large diameter tooling is to be used.

- (iii) For Bosch GOF900A and 1300ACE, three 3/4"x1/4" packing washers are used on each screw to pack out the base of the router from the underside of the insert plate. These packing washers allow the tabs of the inset rings to fit tightly in the plate.

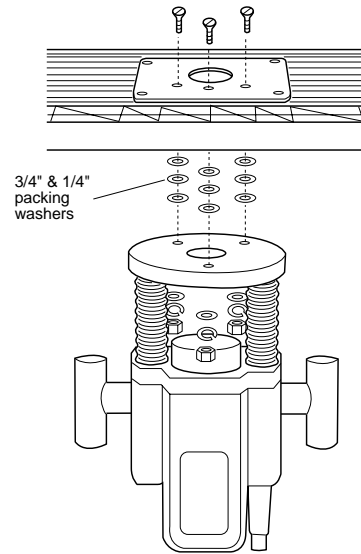

Bosch GOF900A & 1300ACE

E. Re-drilling of Router Base

1. Invert your router onto a suitable surface.
2. Place the **Insert Plate** facing upwards onto the base of your router.
3. Identify holes A1 and A2, or holes B on the Insert Plate.
4. Fit a large diameter cutter (max. 53mm diam.) into your router and tighten collet.
5. Retract plunge mechanism and lock off allowing cutter to protrude through the base.
6. Adjust position of the **Insert Plate** to centralise the cutter within the centre hole of the **Insert Plate**.
7. Ensure that the threaded hole in the **Insert Plate** faces the same side as on/off switch and fine height adjuster (if fitted) so as these are easily accessible when the router is fitted to the table.
8. Ensure that the holes you are about to drill in the base do not interfere with any of the features on the

router or any webbings in the casting of the router base. A slight turning of the plate may be required to miss such obstructions.

- (i) The base of the following routers must be drilled with two 6mm diameter holes:

MOF96(E) Mk1
Black & Decker SR100
AEG OFS450S, OFS50, OFS720, OFSE850
Perles OF808, Stayer PR50
Kango R8550S, Holzher 2335, 2355
Virutex FR77C, 78C

Please see page 33 for plan. Holes B on the plate will be used.

- (ii) The base of the following routers must be drilled with two 6mm diameter holes:

Metabo OF1028, OFE1228
Ryobi R500, R502

Holes A1 on the plate will be used.

9. Mark the centre of the holes onto the base.
10. Remove plate and mark the centre of the holes with a centre punch.
11. Drill a hole at these points with a 6mm diameter drill bit.
12. Clean up edges of holes if required.

F. Re-drilling of Insert Plate

1. Remove or photocopy the plan from the appendix of this manual.
2. Invert the router and lay the plan onto the base.
3. Identify the appropriate holes on the plan to fit your model of router.
4. Line up the plan with the holes on the router and check the accuracy of their positions.
5. Draw cross lines on the **insert plate** with a pencil. These cross lines bi-section the plate on both sides.

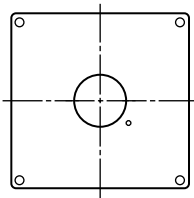

6. Cut around the plan of the router base so that the cross lines drawn on the paper plan are dissected.
7. Line up the lines on the **insert plate** and the lines on the paper plan, ensuring that the threaded insert hole match. Stick the paper plan onto the **insert plate**.
8. Using a centre punch, mark centres of holes.
9. Drill the required hole size with a suitable metal drill bit. Best results will be obtained if your power drill is mounted in a drill stand.

10. Countersink the hole with a countersink bit to a depth so the heads of the screws are slightly below the top surface. Clean off any burrs created.

Note

If you do not have the necessary equipment to carry out operations 7 and 8, then a local engineering shop will be able to carry them out accurately.

G. Re-drilling both Insert Plate and Router Base

1. Invert the router and lay the **insert plate** onto the upturned base, ensuring threaded insert hole is in the correct position.
2. Clamp the **insert plate** and router base together with two cramps.
3. Ensuring that the drill bit will not foul any webbing or fixtures on the router base, drill with a 6mm diameter drill bit into the **insert plate** and through the router base two holes approximately 75mm apart.
4. Unclamp the router base and **insert plate**.
5. Countersink the **insert plate** holes with a countersink bit to a depth so the screw heads are slightly below the top surface. Clean off any burrs created on both the **insert plate** and router base.

H. Fitting Insert Plate to Table Surface

1. Identify the components required, see below.

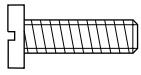

Insert Plate Adjustable Bolts
x 4

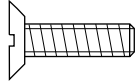

Insert Plate Retaining Bolts
x 4



Nylock Nuts x 8

2. Assemble the four **Insert Plate Adjustment Bolts** and the four **Nylock Nuts** to table as shown in fig. G.1.
After a few turns some resistance will be felt as the screws are gripped by the **Nylock Nuts**. Screw just enough to leave a few threads protruding through the nut.
3. Place the **Insert Plate** into the large opening in the table. The position of the plate should be with the **Threaded Hole** to the front right of the **Table Surface**, see fig. G.2.
4. While pressing down on the **Insert plate**, gradually adjust the **Insert Plate Adjustable Bolts** with a screwdriver until the **Insert Plate** is level with the **Table Surface**. A steel rule or T-square can be placed on the top of the **Insert Plate** to help this levelling process.
The **Insert Plate** must be supported equally on all four **Insert Plate Adjustment Bolts**. When pressure is applied, the **Insert Plate** should be stable.
5. Insert the four **Insert Plate Retaining Bolts** and fit the four **Nylock Nuts** to secure the **Insert Plate** to the **Table Surface**, and tighten securely, see fig. G.3.

I. Fitting Router to Insert Plate

1. Turn the table onto its side, invert the router and line up the **Mounting Holes** in the **Insert Plate**, as identified in section D, with the appropriate securing points in the base of the router.
2. Insert the correct **Router Fixing Bolts**, as identified in section D, through the **Insert Plate** and into router base. Fit appropriate washers and nuts if applicable, see fig. H.

Note

Some models of router will require removal of plastic base prior to fitting, see Section D and pages 6 and 7.

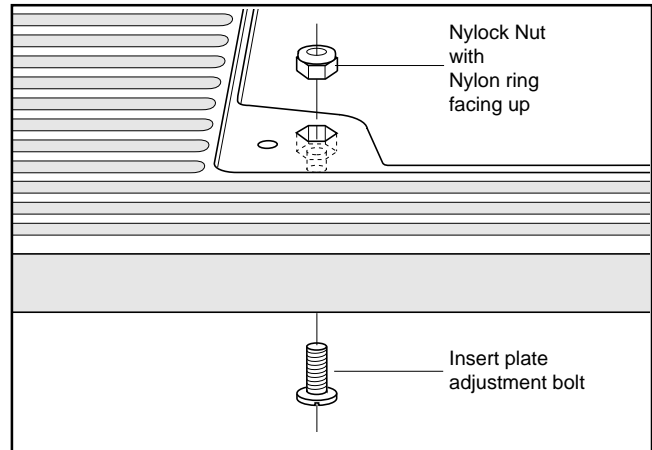

Fig. G.1

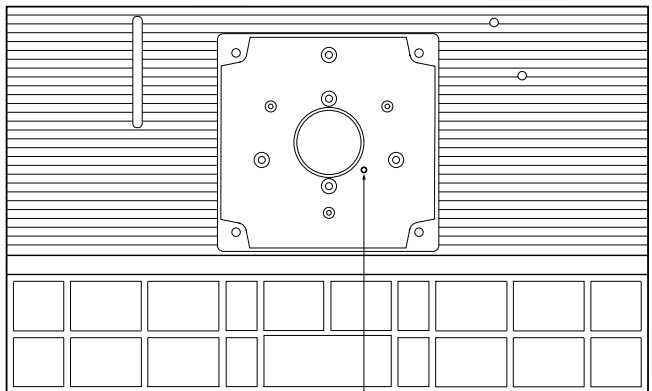

Fig. G.2

Threaded hole for Lead-on Pin

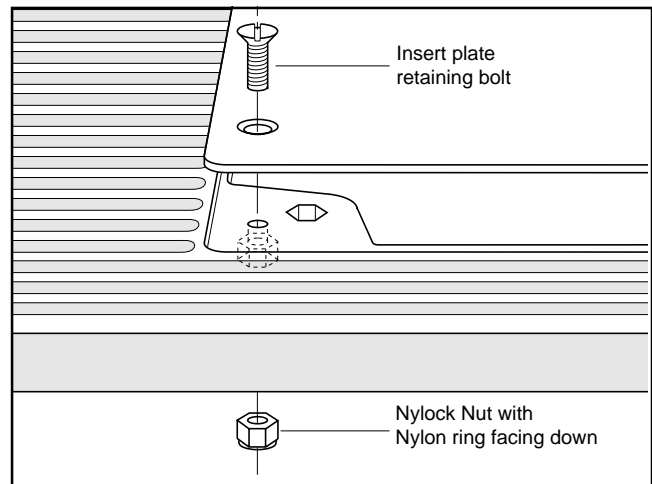

Fig. G.3

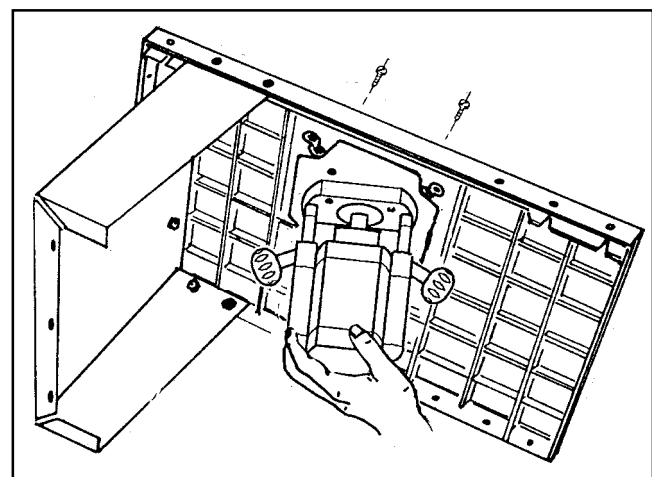

Fig. H

J. Selecting & Fitting Insert Plate Rings

The **Insert Plate Rings** are designed to support the workpiece around the cutter to avoid small timber sections tipping or flexing when being machined.

1. First separate all **Insert Plate Rings** from each other using a sharp knife and trim off all flashes, see fig. J.1.

Selecting the correct size of Ring

2. Select an **Insert Plate Ring** with an inside diameter approximately 1/4" (6mm) larger than the maximum diameter of the cutter to be used. This will give 1/8" (3mm) gap around the cutter to allow the chips to clear.
3. An **Insert Plate Ring** is not required for cutters having a diameter of 1 3/4" (45mm) or larger, as the **Insert Plate** will provide enough support for the workpiece.
4. Do not use router cutters having diameters larger than 50mm (2"). Always ensure the aperture on the base of your router will allow the cutter to protrude through it without touching it.

Fitting Insert Plate Rings

The **Insert Plate Rings** are designed to be snapped into the **Insert Plate**. Slide the large tab under the edge of the **Aperture Hole** in the **Insert Plate** as shown in fig. J.2.

5. Using your thumb, press down on the **Insert Plate Ring** until the small tab snaps into position. Ensure the **Insert Plate Ring** is fully seated into the **Aperture Hole**.
6. To remove the **Insert Plate Ring**, release the small tab from the edge of the **Aperture Hole** and pull the **Ring** out.

K. Fitting Lead-on Pin

The **Lead-on Pin** is a safety feature for profiling straight or shaped workpieces with a bearing guided cutter without using a back fence. It will prevent the cutter from snatching the workpiece, especially when using larger cutters or when making heavier cuts. The use of the optional accessory **Profiling Top Guard** is highly recommended to safely carry out this type of routing operation. See section Y for more information.

Identify the **Lead-On Pin**, see below.

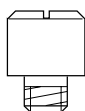

Lead-on Pin x 1

1. Screw the **Lead-on Pin** by hand into the **Threaded Hole** in the **Insert Plate**, see Fig. K.
2. With a flat screwdriver tighten the pin securely.
3. When you do not require the **Lead-on Pin**, keep it in a safe place as it is easily misplaced.

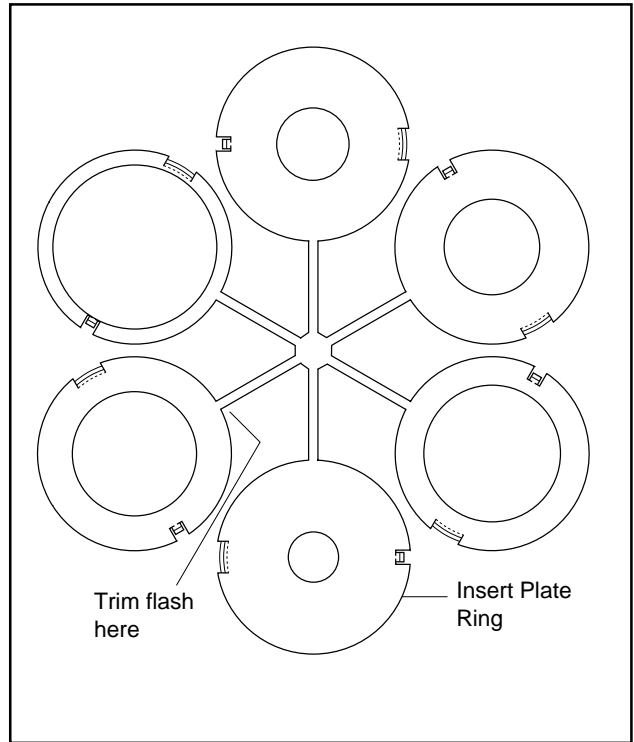

Fig. J.1

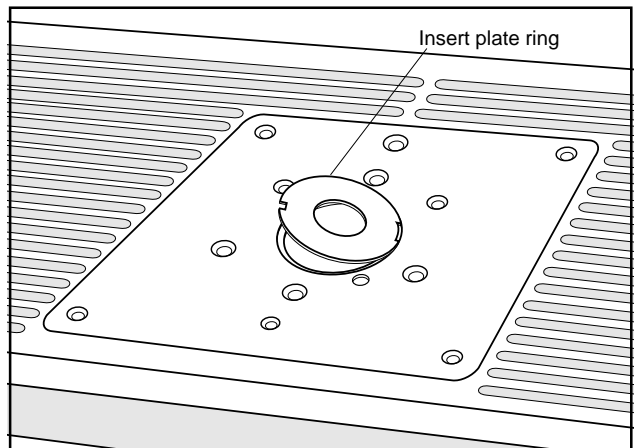

Fig. J.2

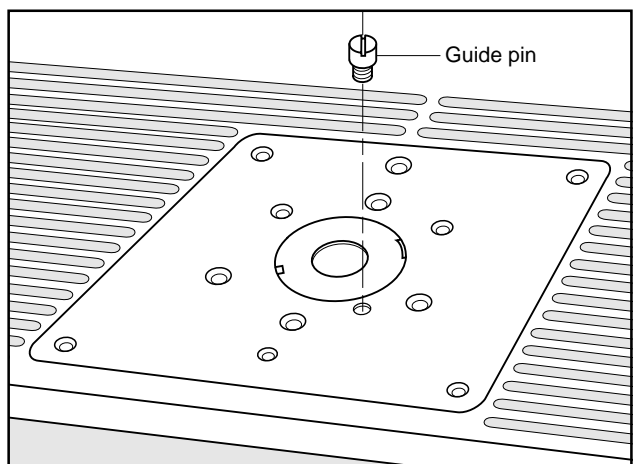
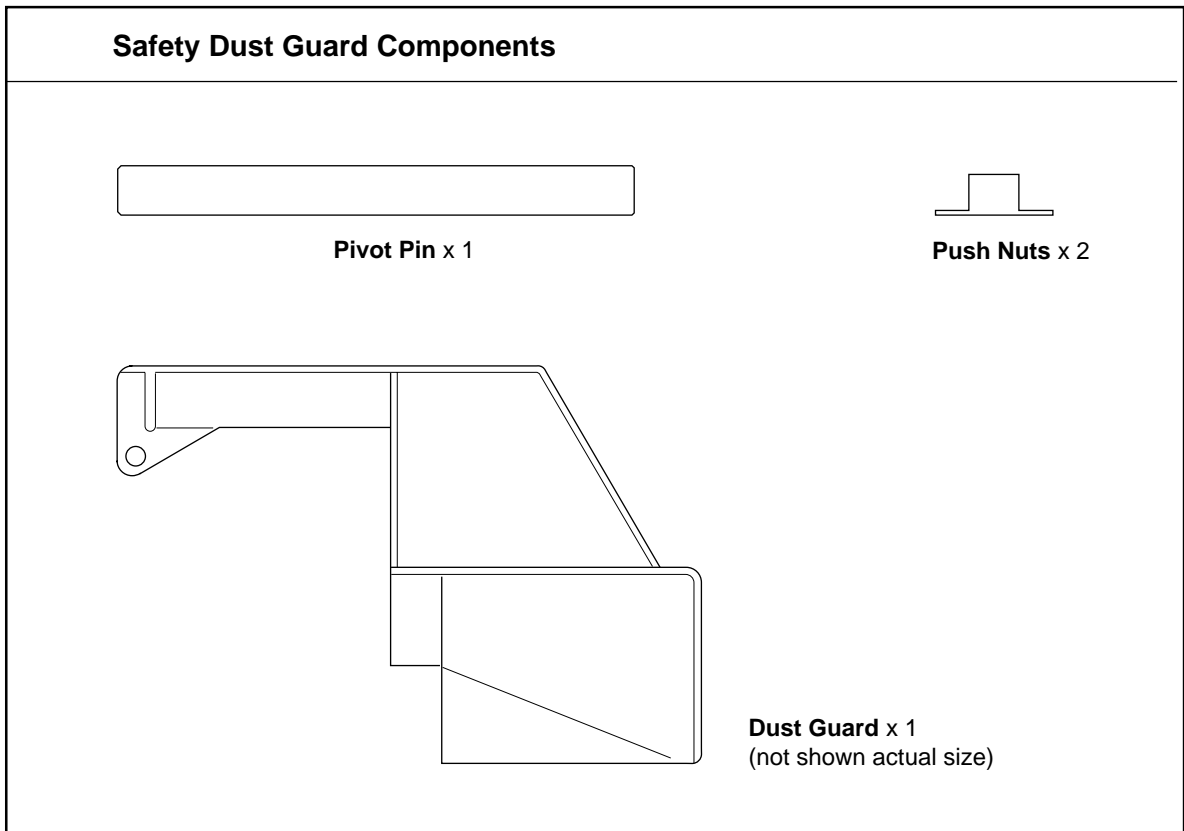
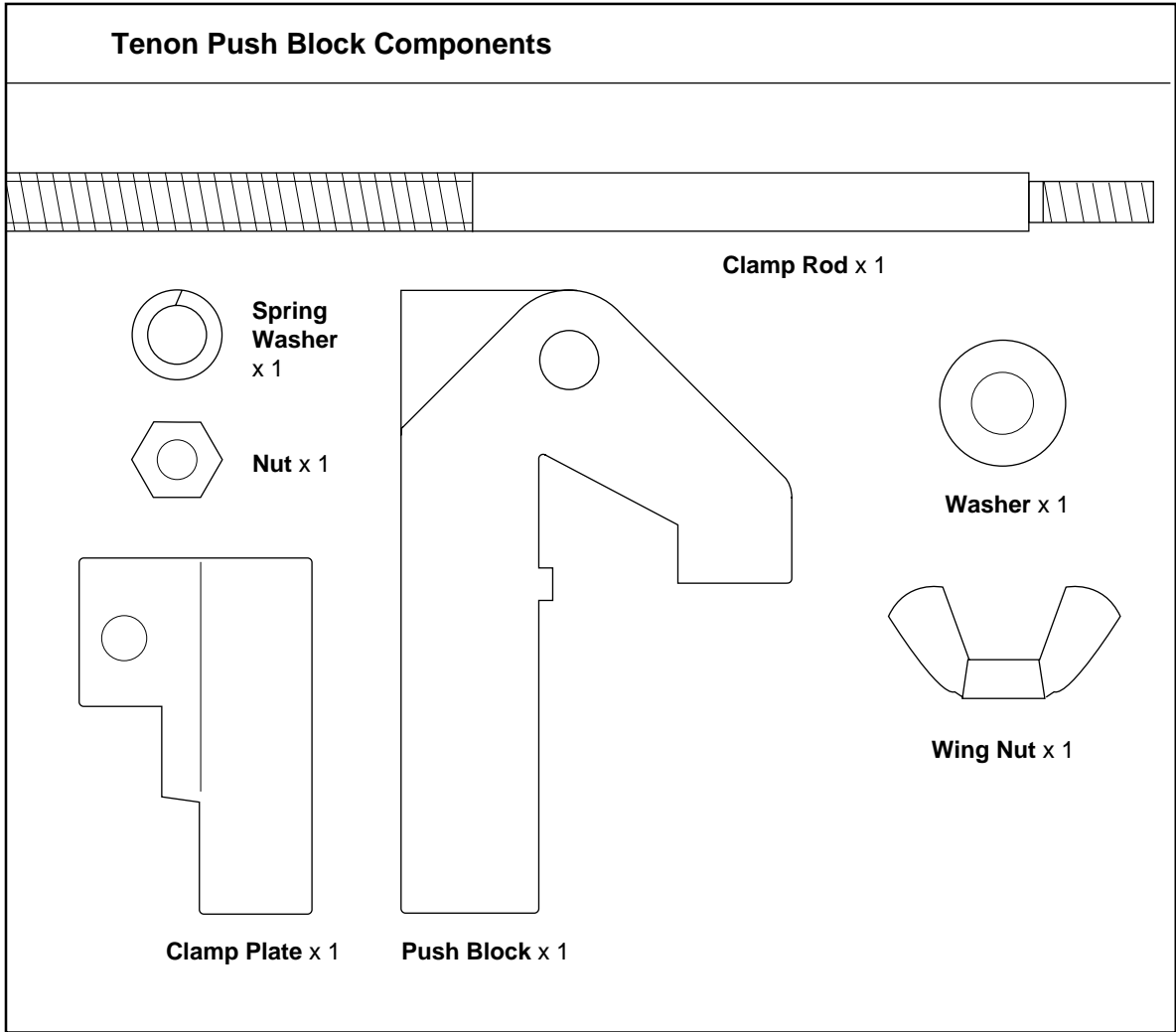

Fig. K



L. Assembly of Tenon Push Block

1. Identify the components required, see opposite.
2. Screw the smaller threaded end of the **Clamp Rod** into threaded hole in **Clamp Plate** until the plate bottoms on it's shoulder (make sure clamp is oriented such that letter 'C' is facing outwards as shown in fig. L.1) and tightly secure **Clamp Plate** to **Clamp Rod** with a 11mm AF spanner.
3. Insert the longer threaded end of **Clamp Rod** through hole in **Push Block** and fit the flat washer and the **Wing Nut** onto it.

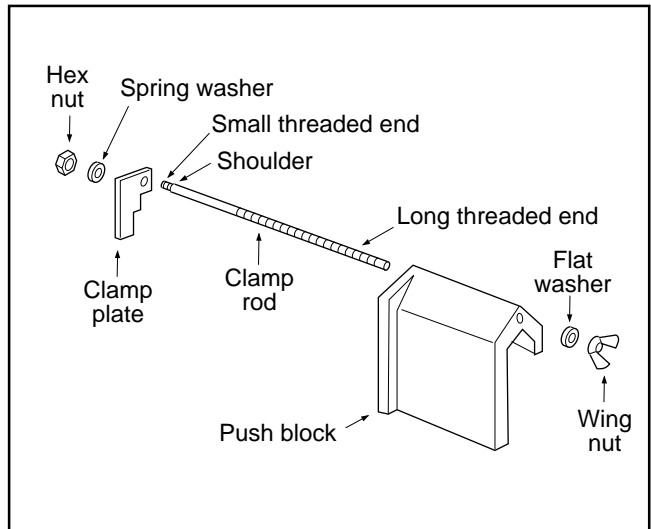

Fig. L.1

Mounting Push Block Assembly on Back Fence

1. Mount assembled **Push Block** on the **Back Fence** by aligning retaining rib on **Push Block** with the groove in the face of **Back Fence**. See fig. L.2.
2. Slide push block assembly back and forth along entire length of **Back Fence** to ensure that it slides freely. Occasional application of furniture spray wax on the sliding surfaces of the **Push Block** will improve the sliding motion.

Removing dust and chips from sliding surfaces of **Push Block** and **Back Fence** will ensure a good sliding motion.

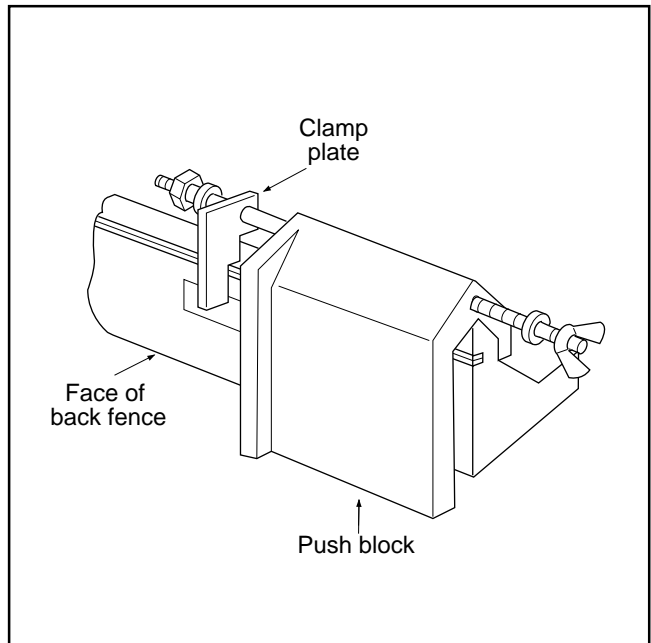

Fig. L.2

M. Assembly of Safety Dust Guard to Back Fence

1. Identify the components required, see opposite.
2. Position the guard on the **Back Fence** as shown in fig. M.
3. Fit one of the **Push Nuts** onto one end of the **Pivot Pin**. (To ensure a secure fitting it will be necessary to tap it onto the pin with a hammer).
4. Align the holes in the **Back Fence** with those on the **Dust Guard**.
5. Insert the **Pivot Pin** through the holes.
6. Fit the remaining **Push Nut** onto the other end of the **Pivot Pin**. It will be necessary to support the other end of the **Pivot Pin** onto the corner of a hard surface in order to tap the **Push Nut** securely onto the **Pivot Pin** with a hammer.
7. Ensure the guard pivots freely.

Note

Once the guard has been installed, it is recommended that the **Push Nuts** are not removed.

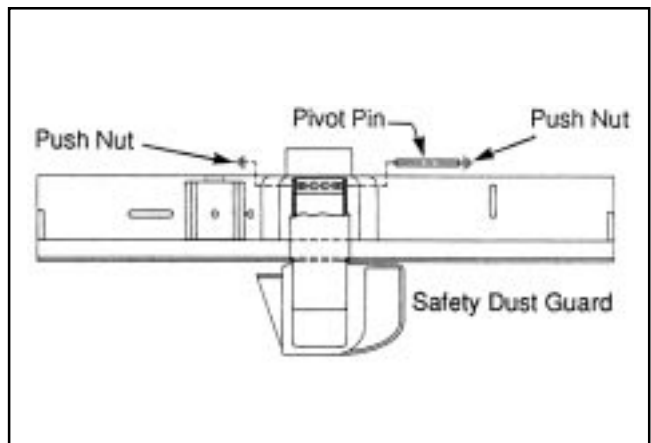
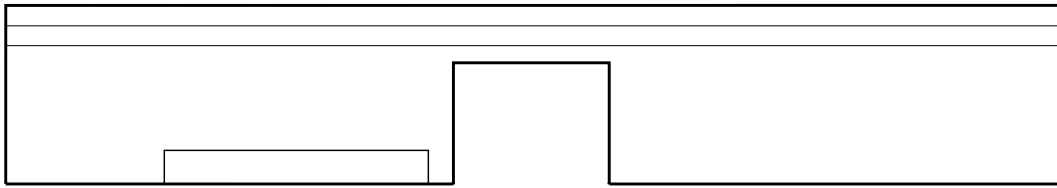
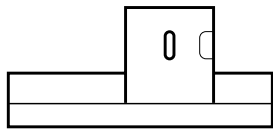

Fig. M

Back Fence Components



Back Fence x 1



Workpiece Support x 1

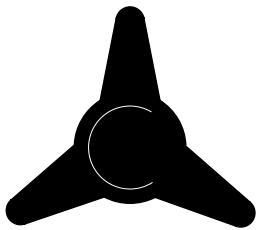

Medium Size Knob x 1

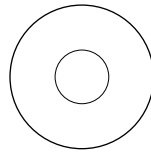

Washer x 1

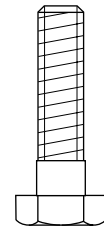

**Workpiece Support
Adjustment Bolt x 1**

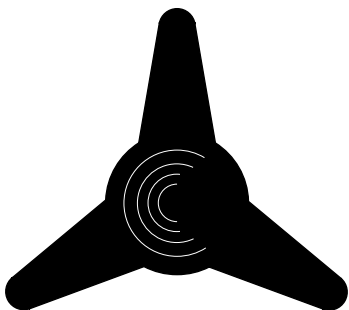

Large Size Knob x 2

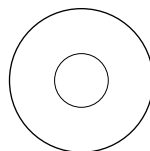

Washer x 2

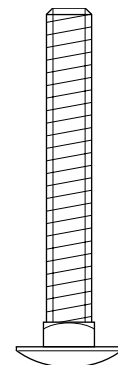

**Back Fence
Fixing Bolts x 2**

N. Assembly of Back Fence

1. Identify the components required, see opposite.
2. Slide **Workpiece Support** through rectangular opening in the aperture provided in the **Back Fence**.
The V-guide on the **Back Fence** should engage in the V-guide on the under side of **Workpiece Support**, see fig. N and page 21 for use.
3. Insert the **Workpiece Support Adjustment Bolt** through the hole in the underside of the **Back Fence** and through the slot in the **Workpiece Support**.
4. While holding the head of the bolt in the hex recess on the underside of **Back Fence**, place the flat washer over the bolt and screw on the **Medium Size Knob**.

When knob is loosened, the **Workpiece Support** should slide back & forth in the aperture for take-up adjustment.

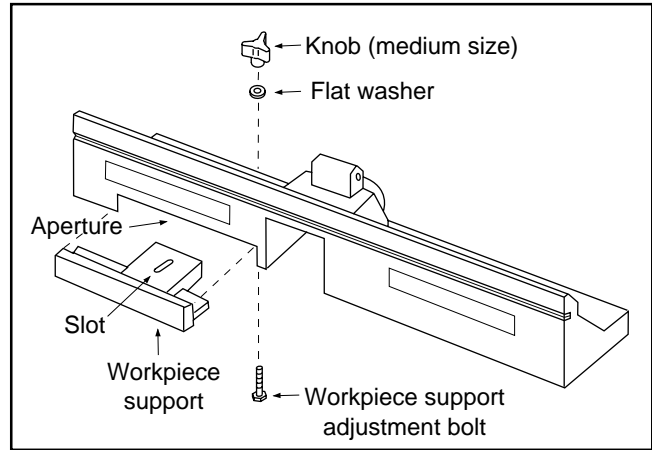

Fig. N

P. Attachment of Back Fence to Table

The **Back Fence** is provided as a guide against which the workpiece should be held for accurate routing. Freehand routing (not holding work against the fence) should be avoided unless the cutter has a bearing guide or pin. Then, the **Lead-on Pin** should be fitted to prevent the cutter from snatching the workpiece.

When attaching the **Back fence** to the **Table Surface**, care should be taken not to knock the protruding cutter, if it has already been fitted.

Two round holes on the right side of the **Table Surface** and one long slot on the left hand side of the **Table Surface** are provided for attaching the **Back Fence**.

For all edge cutting and end cutting operations, attach fence using the front hole and the slot. This will allow adequate adjustment of the **Back Fence** to suit the cutter diameter and depth of cut. See fig. P.2.

For all routing operations away from edge on the under side of workpiece, such as grooving, fluting, veining, attach the **Back Fence** using the back hole and the slot. See fig. P.3.

Dust extraction should be used with the **Back Fence** at all times to prevent clogging of wood waste, see page 18.

1. Position **Back Fence** assembly to **Table Surface** as shown in fig. P.1.
2. Depending upon the type of routing operation, insert one of the **Back Fence Fixing Bolts** through one of the holes on the right side of the **Table Surface** (from the underside) and the short slot in the **Back Fence**. Make sure square shoulder of the bolt fits into the square recess in the underside of the **Table Surface**.
3. While holding the bolt in place, fit the flat washer and large knob onto the bolt to secure loosely the **Back Fence** to the **Table Surface**.
4. Repeat Steps 2 and 3 for table slot and fence slot on the left hand side of the **Table Surface**.

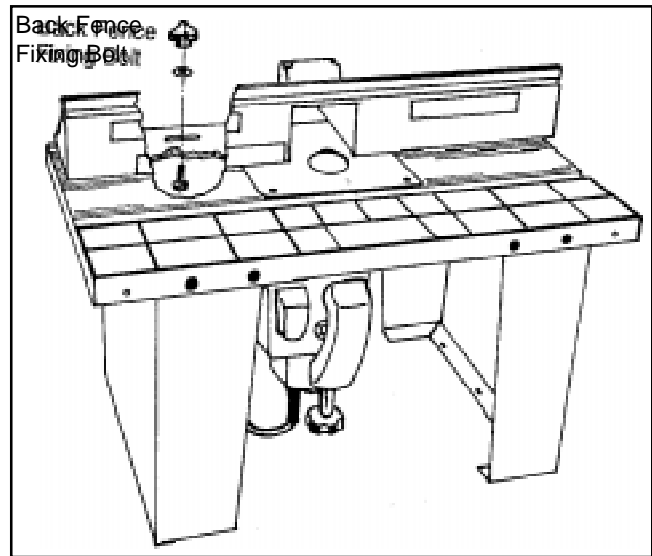

Fig. P.1

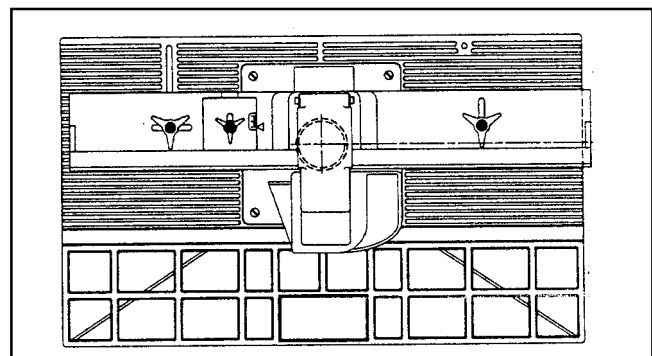

Fig. P.2

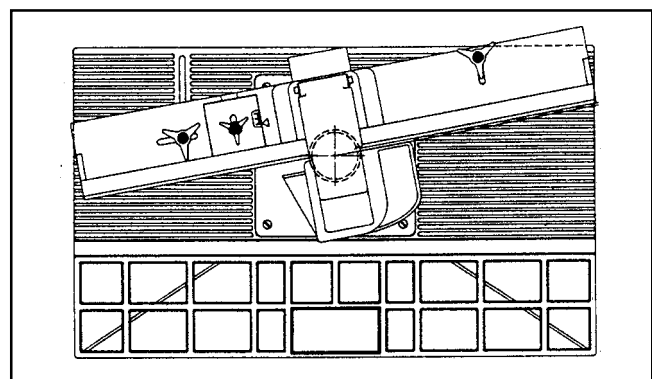
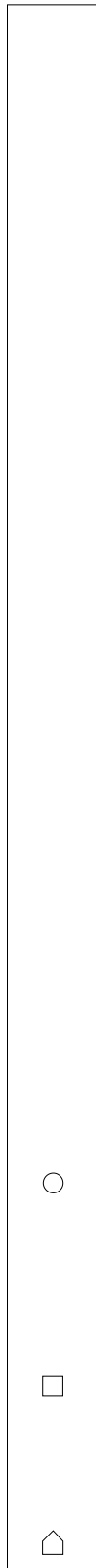
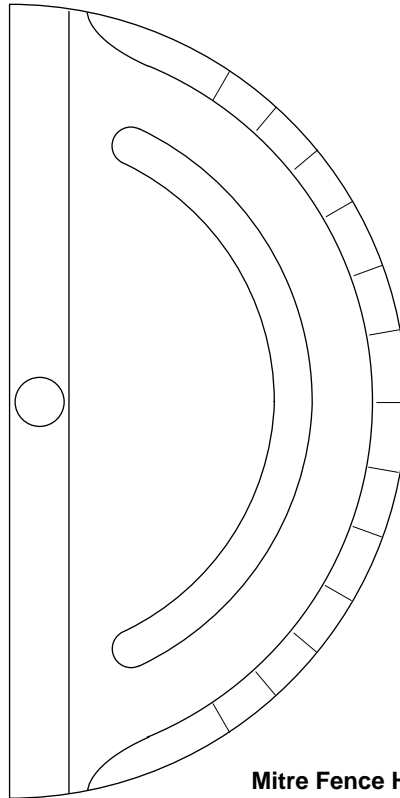

Fig. P.3

Mitre Fence Components



Mitre Bar x 1



Mitre Fence Head x 1



Small Size Knob x 1

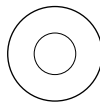

Washer x 1

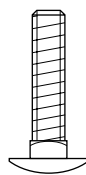

Securing Bolt x 1



Bolt x 1



Pointer x 1



Nut x 1

Q. Assembly of Mitre Fence

1. Identify the components required, see opposite.
2. Insert the pin of the **Mitre Fence Head** into the **Mitre Bar**.
3. Insert the **Securing Bolt** and fit the **Flat Washer** and **Securing Knob** (small size).
4. Remove any flash on the plastic pointer with a sharp knife.
5. Position the pointer as shown in fig. Q.1 and insert the bolt, then fit the nut.

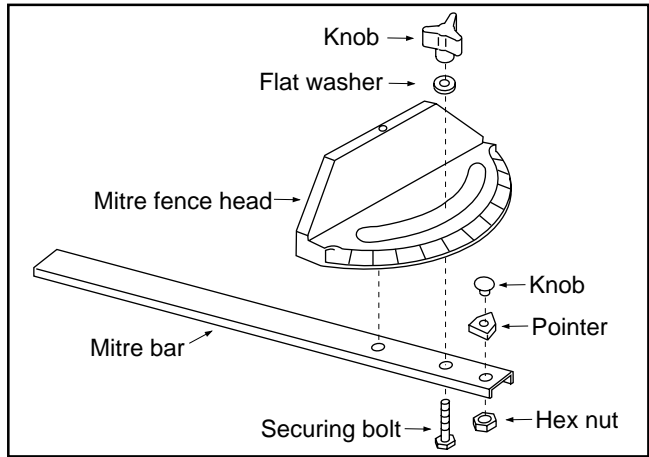

fig. Q.1

Alignment of Back Fence to Mitre Fence Slot

1. Measure the distance from each end of **Back Fence** to edge of **Mitre Fence slot** in the **Table Surface** as shown in fig. Q.2. Adjust the position of the **Back Fence** to ensure both distances are equal.
2. Position **Mitre Gauge** in slot as shown in fig. Q.2.

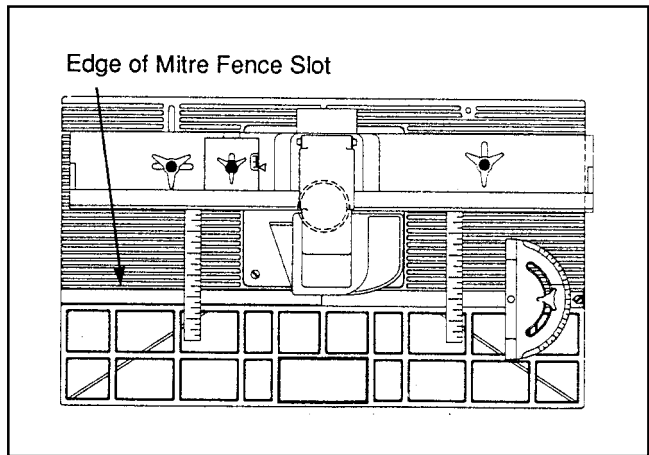

fig. Q.2

R. No-Volt Release Switch - NVRS/230V

(Standard accessory on tables made from 1/3/97)

The **No-volt Release Switch** can be fitted to the table leg or workboard to provide easy access to On/Off buttons. Should the power be turned off at source, the router will not restart until the green start button is pressed. The switch is for use with 230 volt routers up to 1850 watts.

1. With the fixing kit supplied, mount the **No Volt Release Switch** on the right side of the router table using the holes already drilled.

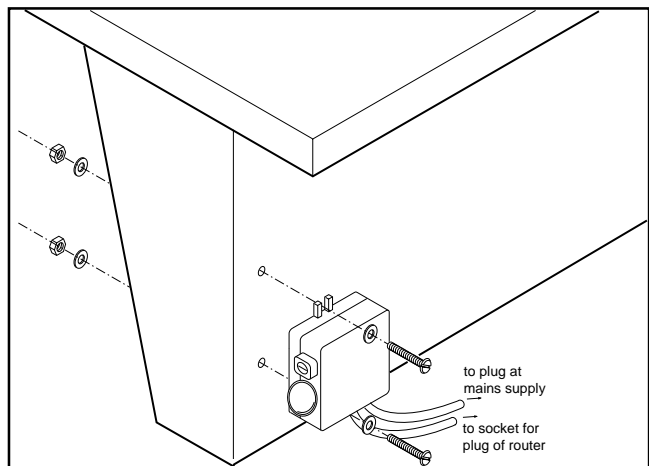

fig. U.1

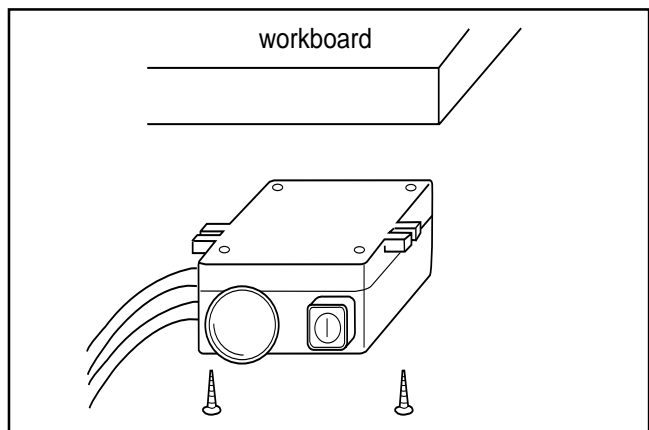

fig. U.2

OPTIONAL ACCESSORIES

R. Dust Extraction Equipment

The **Back Fence** is provided with an extraction point for fitting to suitable dust extractors. The internal hole diameter is 57mm (2 1/4"). Suitable fittings with 57mm outside diameter are available with most extractor units.

Only a dust extractor unit recommended for use in the workshop should be used.

A suitable adaptor and extraction hose can be purchased as optional accessories as follows:

Extraction Hose - 39mm OD - 3 metre length.....CRT/4

Hose Adaptor - 58mm OD to 39mm ID.....CRT/3

The hose has an outside diameter of 39mm and inside diameter of 32mm and is designed to fit the hose adaptor. The hose adaptor is a unique design allowing it to

swivel freely when fitted to the hose.

Assembly of Hose Adaptor

1. Slide **Adaptor Clip** onto end of the **Extraction Hose CRT/4** with tabs facing outwards.
2. Screw the **Adaptor Fitting** anti-clockwise onto hose, ensuring that the **Extraction Hose** is screwed in all the way.
3. Fit the **Adaptor Tube** by locating the holes with the tabs of the **Adaptor Clip**.
4. Push the assembly into the back fence connection point with a slight twisting action to ensure a tight fit.
5. Fit the other end of the extraction hose to your dust extractor.

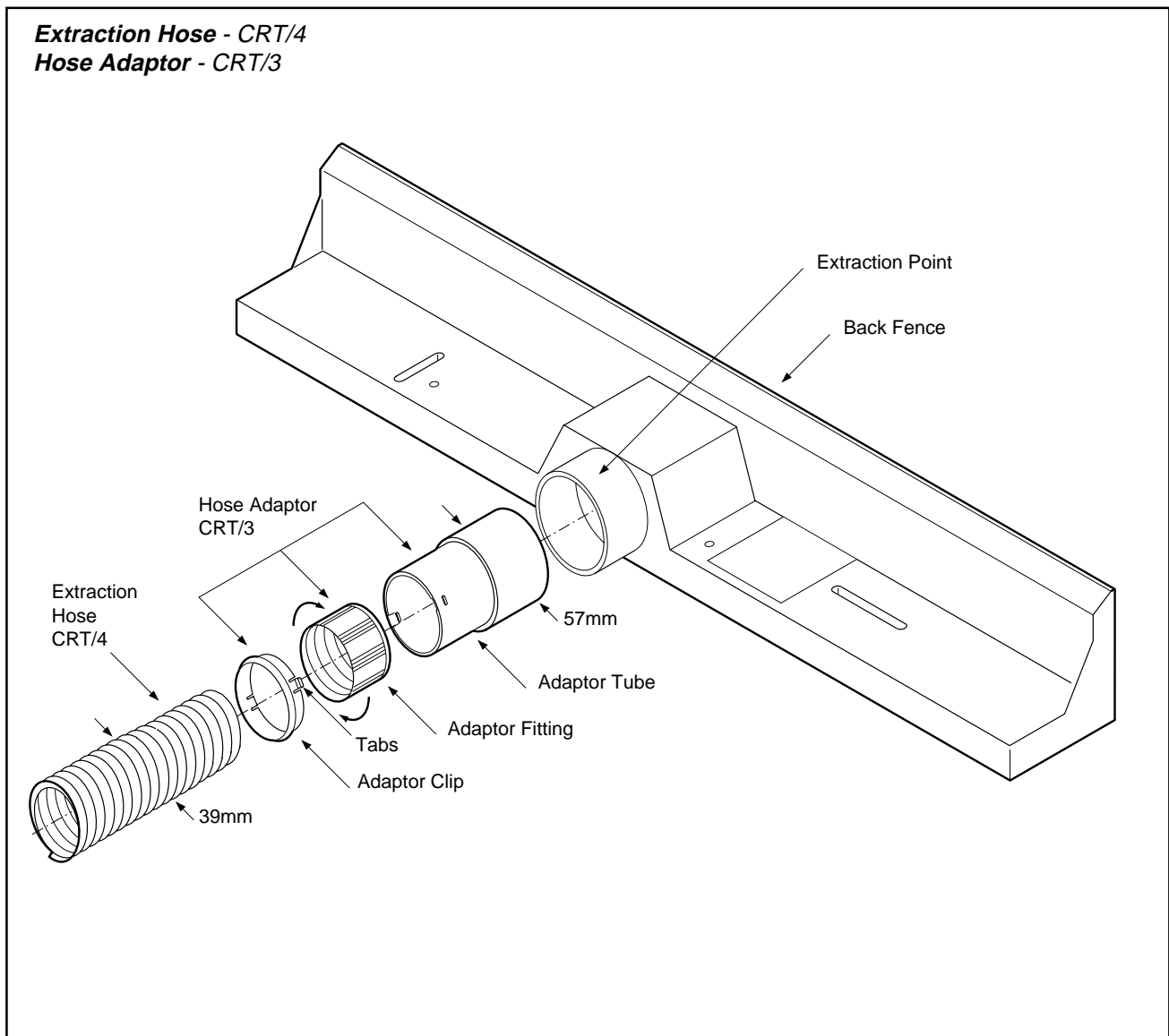

fig. R

T. Assembly of Spring Pressure Clamps

The **Optional Spring Pressure Clamps** can be mounted to the **Back Fence**. When adjusted to suit the width and thickness of the material, it ensures the material is held down onto the surface to obtain accurate machining of the workpiece.

The **Back Fence** is pre-drilled to accept both **Spring Pressure Clamps**.

1. Remove **Back Fence** from **Table Surface**
2. Insert **Vertical Pillar Bolt** through the underside of the **Back Fence**.
3. Fit washer and screw on the **Vertical Pillar**. Tighten screw securely to ensure pillar is vertical.
4. Fit knobs to **Connector Block** and slide it onto **Vertical Pillar**.
5. Slide **Horizontal Bar** through **Connector Block**.

6. Slide **Pressure Strip** into the slot in **Horizontal Bar** aligning the holes. Insert the **Retaining Screw** ensuring it goes in through the un-threaded side of the hole first.

Before tightening the **Vertical Pillar Bolts**, ensure that the **Vertical Pillar** will allow the block to be positioned parallel to the **Back Fence** with the knob engaging on the flat of the **Vertical Pillar**.

Adjustment

The **Spring Pressure Clamps** will require adjusting to suit the height and width of material being routed. The **Pressure Strips** should provide enough pressure to prevent the material lifting from the **Table Surface**, but not too much as to create friction which would prevent the material from sliding freely. The block assembly with **Horizontal Bar** and **Pressure Strip** can be removed from the **Vertical Pillars** when not required. The **Vertical Pillars** can be left in position and will not impede the **Tenon Push Block** system.

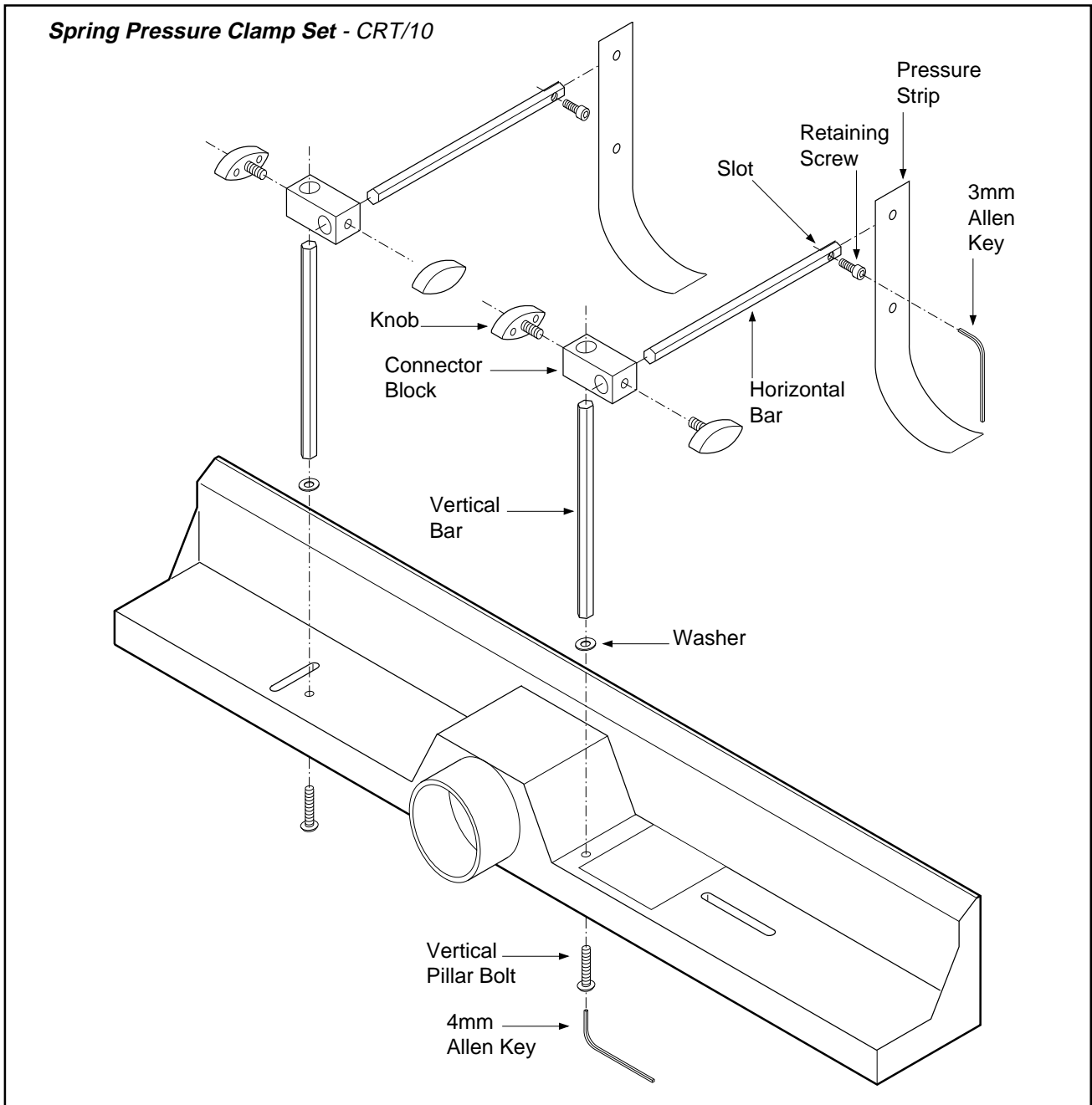

fig. 5

U. Assembly of Profiling Top Guard

The use of the optional accessory, **Profiling Top Guard** is highly recommended to safely carry out the profiling of workpieces with a bearing guided cutter. It will prevent the operator's fingers inadvertently contacting the cutter.

1. Fit the **Bolt, Star Washer, Spring Washer** and **Nut** in the sequence as indicated below.
2. Tighten nut securely with a 8mm spanner.
3. Fit **Plate, Washer** and **Wing Nut**.
4. Slide the **Perspex Guard** in between the **Plate** and edge of **Table Surface**.
5. Gently tighten **Wing Nuts**.

Adjustment

1. The height of the **Perspex Guard** should be adjusted to leave a 6mm to 12mm gap between the top of the workpiece and the underside of the guard. This will prevent fingers coming into contact with the cutter.
2. To adjust the height undo the wing nuts, re-position the guard and retighten.

Section Y describes a typical application involving the use of bearing guided cutters with the Router Table.

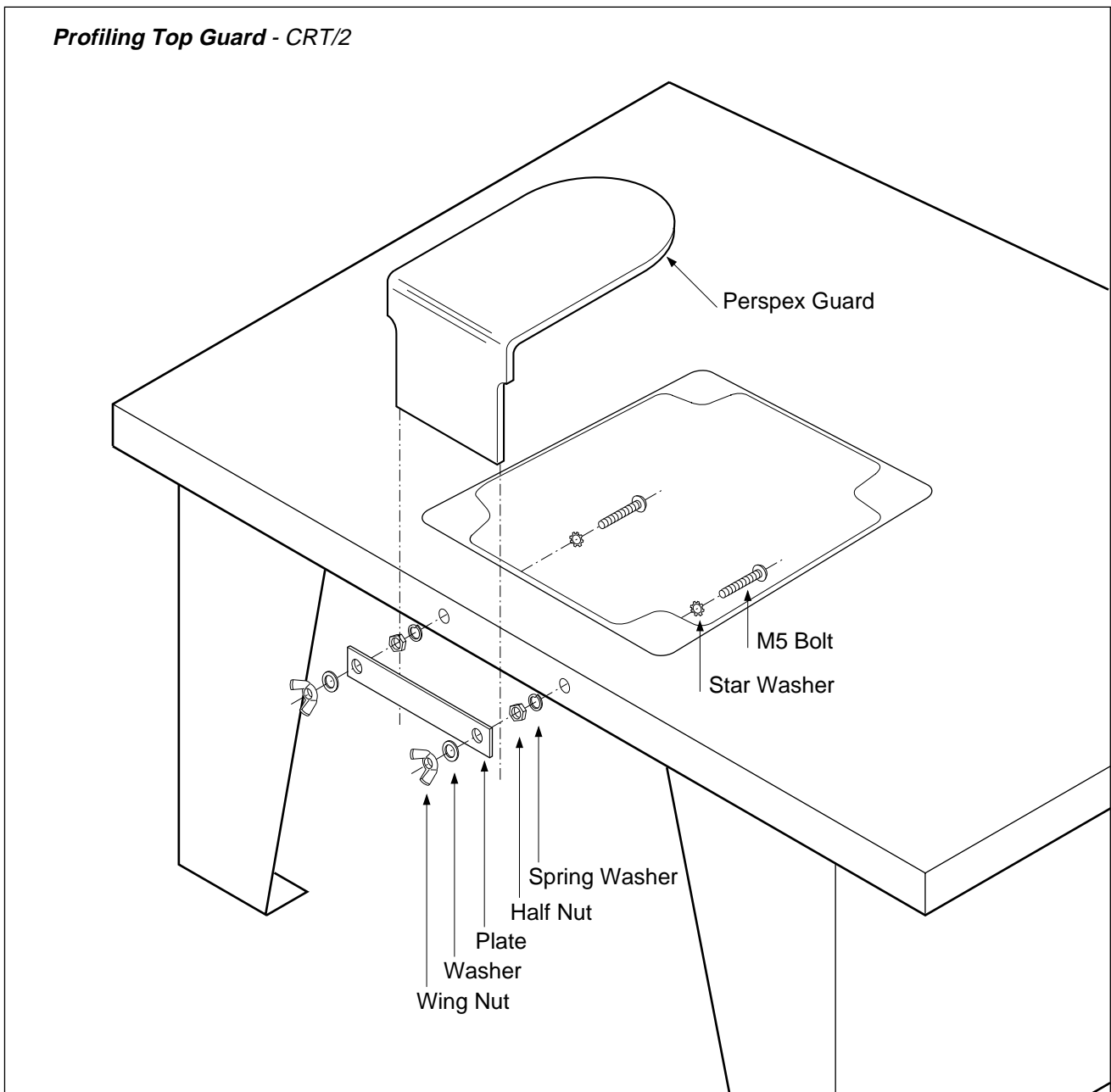

fig. T

OPERATION

V. Edging and Profiling using the Back Fence

The router table has many advantages when profiling and edging operations are to be carried out especially on narrow workpieces. A Fine Height Adjuster fitted to the router will make adjustment of the height far easier and hence is highly recommended.

NOTE: Make a test cut on a piece of waste material prior to carrying out any routing operation.

1. Mark the width and depth of cut required onto the end of the timber. See fig. V.1 for typical profiling and edging operation which can be carried out.
2. Place timber up against **Back Fence**.
3. Release **Back Fence Fixing Bolts**.
4. Adjust **Back Fence** until required width of cut is achieved. See fig. V.2a.

If bearing guided cutters are used, ensure that the **Back Fence** is in line with the bearing or slightly behind it. The **Back Fence** will give more support and provides the retractable **Safety Dust Guard** and **Spring Pressure Clamp** facility.

5. Lock **Back Fence Fixing Bolts**.
6. Release plunge mechanism on router.
7. Adjust the depth of cut using the **Fine Adjuster** (if fitted), see fig. V.2b.
8. Lock-off plunge mechanism of router.
9. Lower **Safety Dust Guard** and check it will retract freely over the workpiece.
10. Adjust the **Spring Pressure Clamps** (if fitted) to suit the thickness and width of the timber.
11. Ensure that you have a **Pushstick** within easy reach when routing.
12. Switch on router.
13. Pass timber over cutter with a constant feed speed.

Ensure even pressure is kept on the workpiece down onto the table and against the back fence.

Always ensure that your hand positions are never near the cutter.

Use the correct procedure as shown in figs. V.3a - c. Use the push stick to safely maintain pressure on narrow timbers.

14. The **Workpiece Support** can be used to plane an edge. The cutter should be set approximately 2mm proud of the **Back Fence**. The material should be routed until the planed edge passes onto the outfeed fence. Switch off router, slide or pivot material away from cutter. Replace material and bring **Workpiece Support** out until it touches the material. Tighten knob and continue routing.

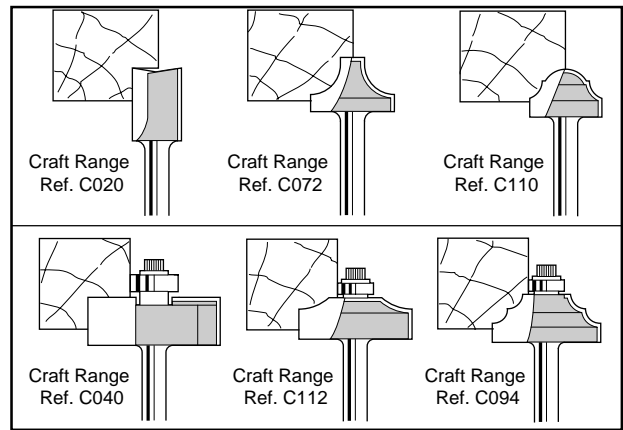

fig. V.1

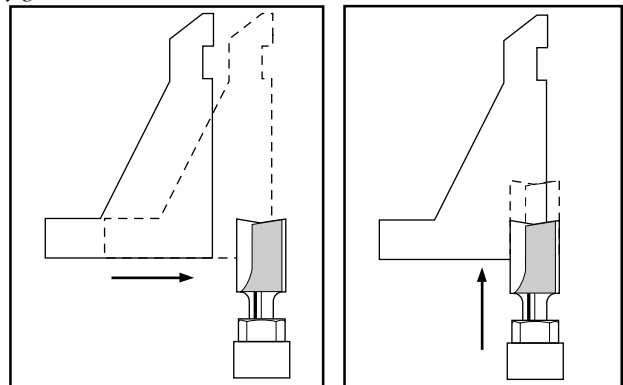

fig. V.2a

fig. V.2b

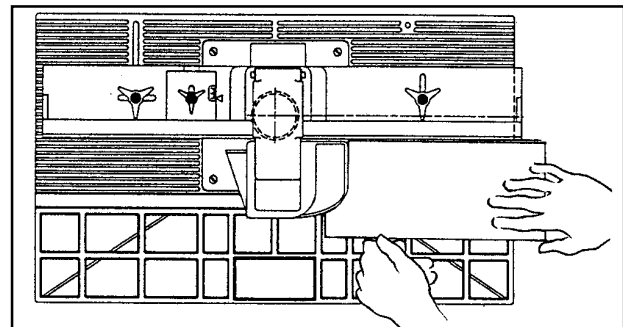

fig. V.3a

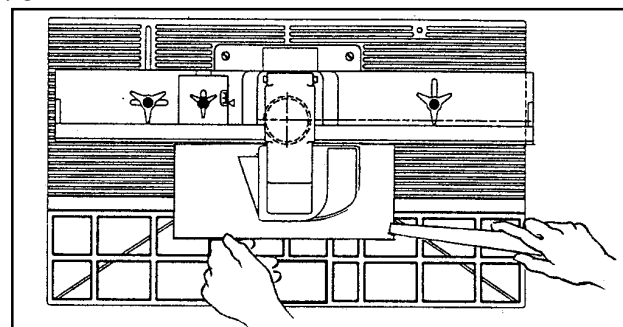

fig. V.3b

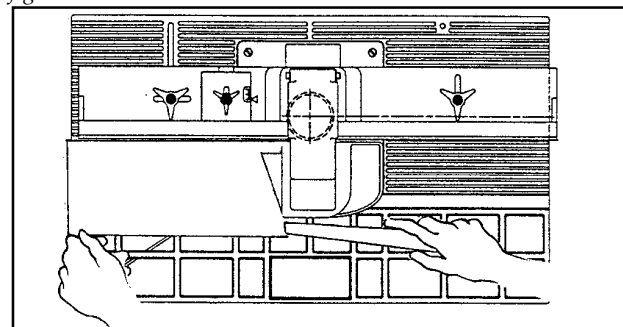

fig. V.3c

W. Using Router Table for Grooving

The router table can be used for operations away from the edge of the workpiece such as grooving, fluting, veining, etc.

Always unplug the router before making any setting, adjustments, or changing bits.

When routing, always feed against the rotation of the cutter. Feed workpiece in the direction of arrow in fig. W.2.

For maximum accuracy, one edge of your workpiece (edge sliding against the fence) must be true and straight.

Set up your fence as follows:

1. Raise **Safety Dust Guard** and rest it against the extraction point.
2. Position the fence behind the router bit for the desired cutting depth (the distance of cut from the edge of the workpiece, as shown in fig. W.1).
3. Securely tighten **Back Fence Fixing Bolts** and lower the guard over the cutter.
4. Make the cut by sliding the straight edge of workpiece against the fence. Use a **Pushstick** as shown in fig. W.2. (For each successive cut, the fence would need to be re-adjusted).

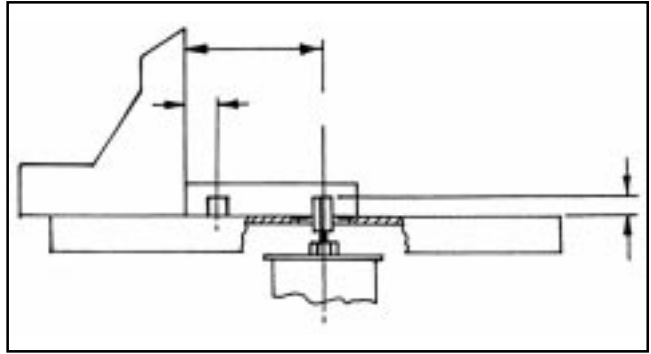

fig. W.1

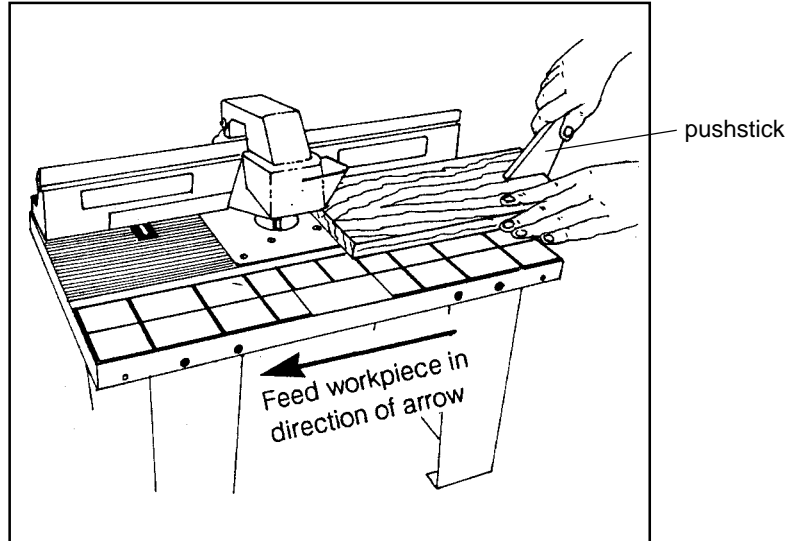

fig. W.2

X. Using Mitre Fence

Your **Mitre Fence** will be required to give extra support for routing small workpieces or ends of large workpieces. See fig. X.

NOTE:

For all routing operations requiring use of the **Mitre Fence** along with the fence, be sure to align fence with mitre bar slot before making any cuts.

It is advisable to fit a waste piece of material to the **Mitre Fence** or behind the component to prevent breakout of the wood grain.

If using **Mitre Fence** to trim the end off a piece of material, the **Workpiece Support** can be brought forward with the cutter to support the material after the cut, see fig. X.

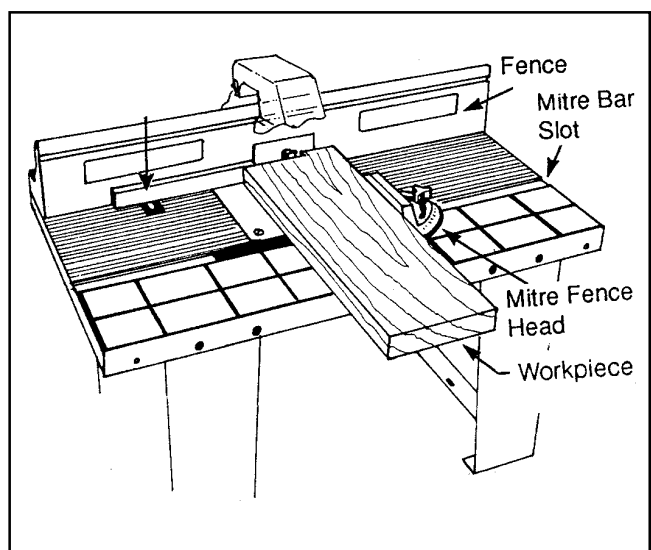

fig. X

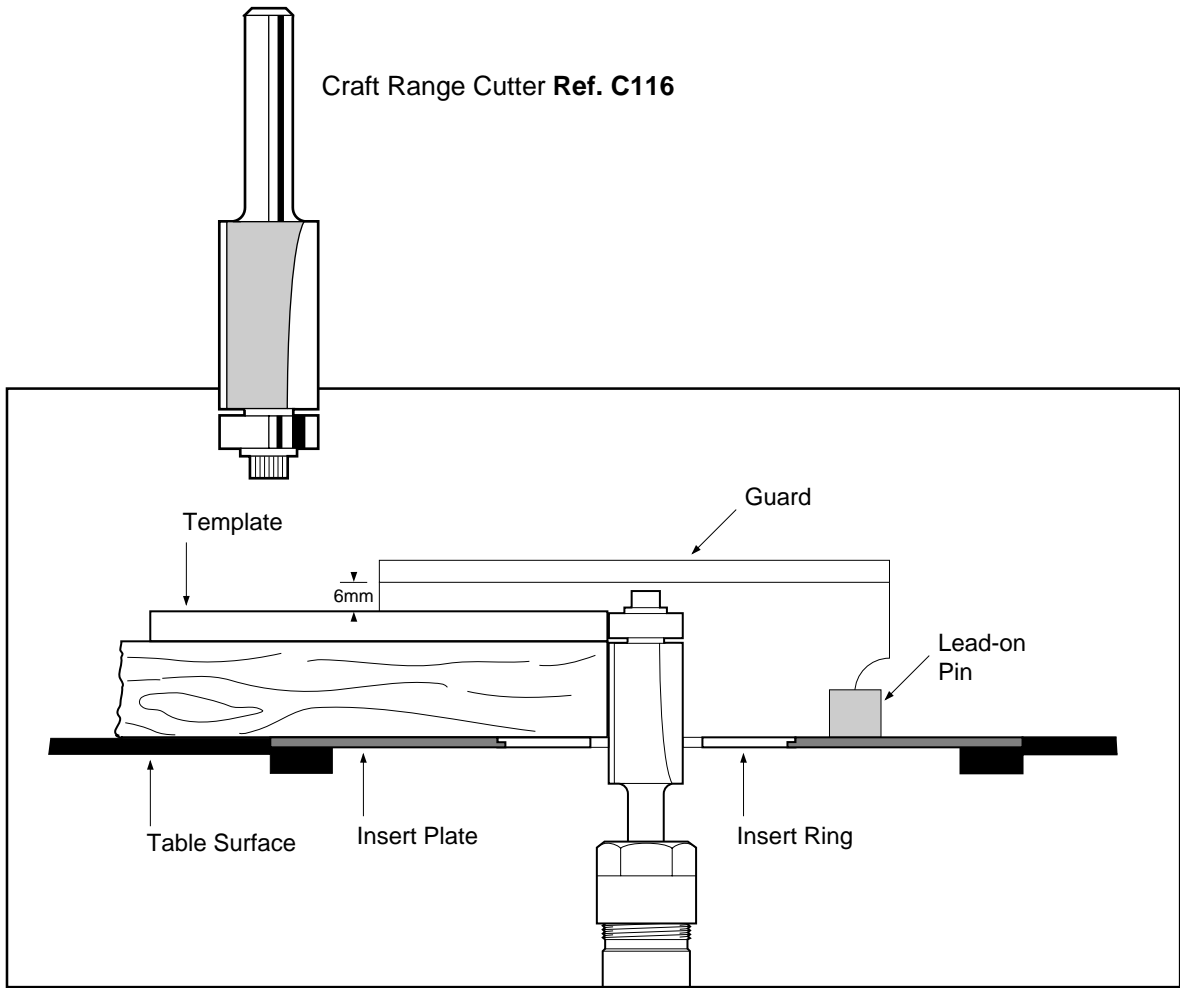

fig. Y.1

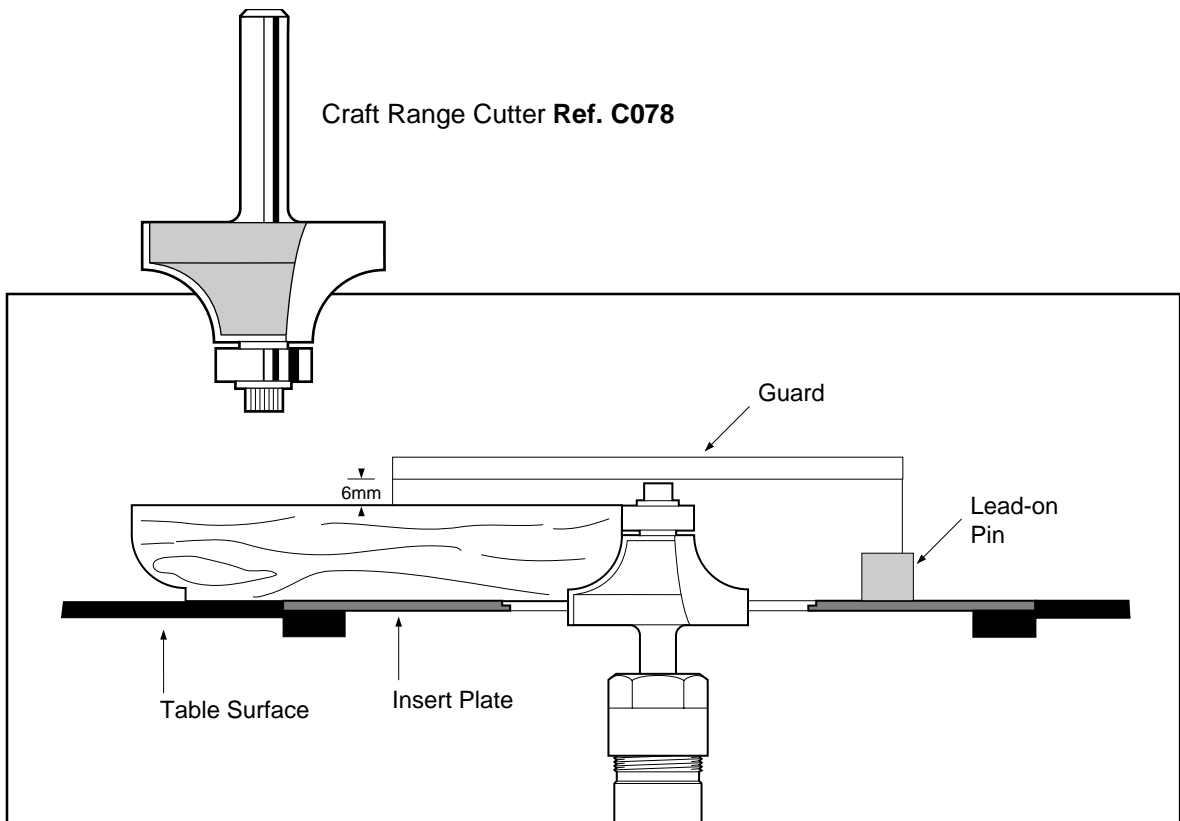
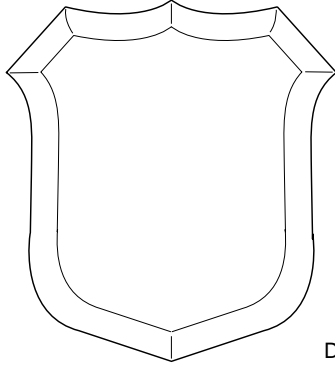

fig. Y.2

Y. Using The Profiling Top Guard

Example

A typical application using the **Profiling Top Guard** is in the routing of shields from MDF Board (Medium Density Fibreboard) as follows:



Design of shield

Producing a Shield

1. Construct an actual size template of the shield design from 6mm MDF, hardwood or plywood ensuring that it is accurate and free from imperfections. Remember the finished product will only be as good as the template.
2. Fix the template to the back of the workpiece to be used using screws or double sided tape.
3. Rough cut the workpiece to the shape of the template using a band saw or jigsaw leaving 2-3mm oversize.
4. Remove the **Back Fence** assembly from the table.
5. Fit the **Lead-on Pin** as described in section K.
6. Fit the fine height adjuster if one is available for your router. This will allow the height of the cutter to be adjusted accurately.
7. Fit a self-guided trimmer cutter.
8. Lay the workpiece (with template fitted) face down on the table surface. Adjust the height of the cutter using the plunge and lock mechanism on the router or use the fine height adjuster (if fitted). Ensure that the bearing will contact the template and the cutting edge of the cutter will machine the full edge of the workpiece. See fig. Y.1.
9. Lock-off plunge mechanism of router to ensure that the plunge mechanism will not inadvertently move during routing.
10. Fit the **Profiling Top Guard** as described in Section T and adjust height to give a 6-12mm gap between the top of cutter and underside of template.
11. Switch router on and allow to reach full running speed.
 - a. Position the workpiece against the **Lead-On Pin** as shown in fig. Y.3. The Workpiece should not contact the cutter.
 - b. Gradually swing workpiece towards cutter until template engages the guide bearing.
 - c. Feed workpiece against the rotation of the cutter whilst swinging the workpiece away from the **Lead-On Pin**. At this point the guided bearing is acting as the guide. Progressively feed the workpiece anti-clockwise around the shape of the template ensuring that the guide bearing always stays in contact with the template.
 - d. When the complete edge of the workpiece has been machined, slide the workpiece away from the cutter.

If you are unfamiliar with the above procedure then the technique should be practised before switching on the router.

Special Notes

1. Always keep the workpiece moving in a precise steady movement to prevent the material from burning.
2. Never let go of the workpiece. Always keep an even pressure of the workpiece against the bearing. Do not use too much pressure.
3. If you wish to stop routing halfway through the operation. Simply slide the workpiece away from the cutter before switching off the router.
4. If the template inadvertently comes away from the bearing and so does not emulate the template, do not stop. Complete the operation and repeat the procedure for the edge concerned.
5. It is advisable to repeat the operation in order to improve the finish of the workpiece.
6. Keeps hands away from the cutter, even if the guard is fitted, in order to give a good safety margin.

Minimal finishing should be required before the next operation. If natural woods are used, consideration should be given to breakout of short grain which will effect your decision as to where to start the routing operation in order to prevent it.

Moulding the Shield

A suitable bearing guided cutter should be chosen to mould the shield.

1. Remove plug from mains.
2. Fit chosen moulding cutter.
3. Adjust height of cutter to achieve shape required. If the full edge of the workpiece is to be machined leave the template attached to the workpiece so as to provide a guide for the bearing. Otherwise the template can be removed, providing there is sufficient edge for the bearing to follow. See fig Y.2.
4. Repeat the same routing procedure as before. If the profile required involves excessive removal of material, it is advisable to take two passes with the cutter. First reduce the height of the cutter protruding from the table, this in effect, reduces the amount of material which will be removed, or fit a larger bearing, if one is available for that particular cutter. The second pass can then be made to give the required finish.

Carrying out this two stage routing operation has many advantages.

- a. Improved finish on workpiece
- b. Less load on cutter and router
- c. Far less risk of workpiece snatching

Definition of Snatching

This can be described as the cutter catching the workpiece and projecting it away from the direction of rotation. The workpiece is often taken from the operator's hands and projected across the work area. It can have potentially dangerous consequences if the cutter is unguarded and/or the operator's hands are too close to the cutter. Damage to the cutter can also be caused.

The following precautions should be made to avoid a potentially dangerous situation:

1. Fit the **Profiling Top Guard**, this will prevent fingers contacting the cutter.
2. Always rout in the direction which opposes the direction of rotation of the cutter. Routing with the direction of the cutter is called back-cutting and will cause snatching.
3. Use the **Lead-On Pin** to provide support for the workpiece during the initial start of the routing operation, it will also ensure that you approach the cutter from the correct side.
4. When a deep cut is required or the material is particularly dense, then take two or three passes.
5. Ensure the cutter always has a sharp cutting edge.
6. Do not reduce pressure of the workpiece or let go of it. Always keep both hands on the workpiece and keep an even pressure against the guide bearing.
7. Do not use too great a feed speed. If the revolutions of the router drop, it is a good indication that either too deep a pass is being made and/or the cutter is blunt. Therefore reduce the depth of cut and/or sharpen your cutter.

If the above points are followed, profile routing using bearing guided cutters is both safe and rewarding. It is however advisable for those new to routing to avoid using larger diameter cutters until proficient with the technique described. Under no circumstances should this type of operation be carried out with cutters not having a guide ball bearing or pin.

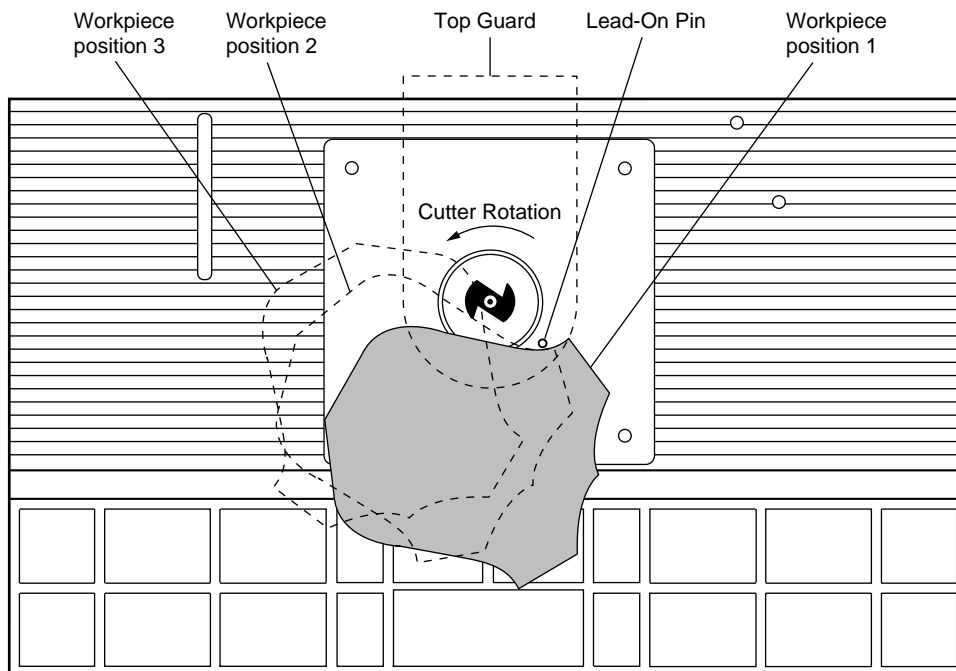

fig. Y.3

Z. End Cutting with the Tenon Push Block

The Push Block facility is ideal for producing tenons and sliding dovetails.

The retractable dust guard cannot be used when carrying out push block operations. Therefore extra care must be taken to ensure that hands are kept well clear of the cutter.

Ensure that the workpiece is true and the end is square and smooth.

1. Mount push block assembly on the **Back Fence**, see section L.
2. Fit the correct insert ring into the the insert plate to suit the diameter of the cutter being used, see section J.
3. Adjust the height and depth of the cutter to suit the cut required.
4. Position workpiece between **Clamp Plate** and **Push Block** so that it's side is flush against the face of the **Back Fence**, the end to be cut is resting on the edge of the insert plate hole and edge marked with lines 'A' and 'B' is facing the router cutter. Clamp workpiece in this position by tightening the **Wing Nut** on the **Clamp Rod** while making sure that **Clamp Plate** stays orientated on workpiece. See fig.Z.2.
5. Slide **Push Block** and workpiece back to the position as shown in fig.Z.3. When routing, always feed against the rotation of the cutter. Feed workpiece in the direction shown by the arrow.
6. Switch router on. While holding **Push Block** and guidig workpiece against fence with both hands and fingers at a safe distance from cutter (fig.Z.3).
7. Turn router off, unclamp workpiece and slide **Push Block** back to original position.
8. Position and clamp the opposite side of workpiece (make sure the wing nut is tight just enough to clamp workpiece in position and end to be cut is resting on the edge of insert plate hole). Repeat step 6 and 7.
9. To cut ends of tenon, position and clamp workpiece so that the edge of the workpiece is held flush against the face of the fence and end to be cut should be resting on edge of insert plate hole. See fig.Z.4. Repeat steps 6 and 7.
10. A scrap piece of timber should be placed behind the workpiece to prevent breakout.

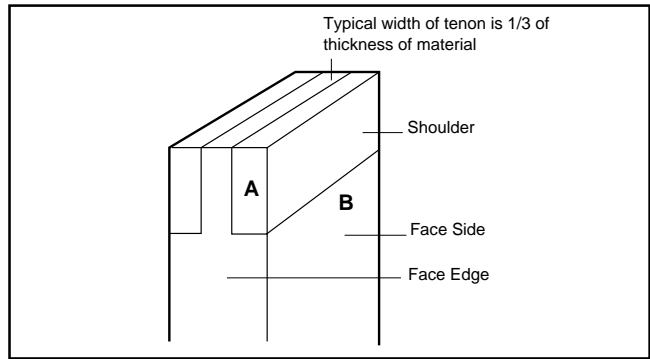

fig. Z.1

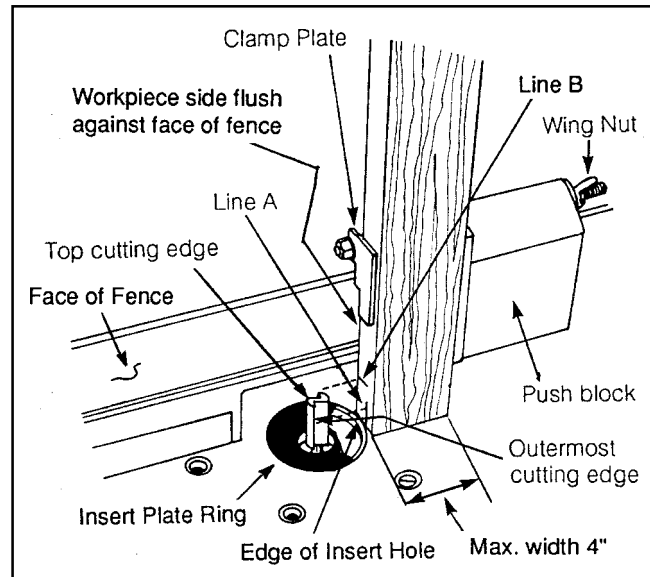

fig. Z.2

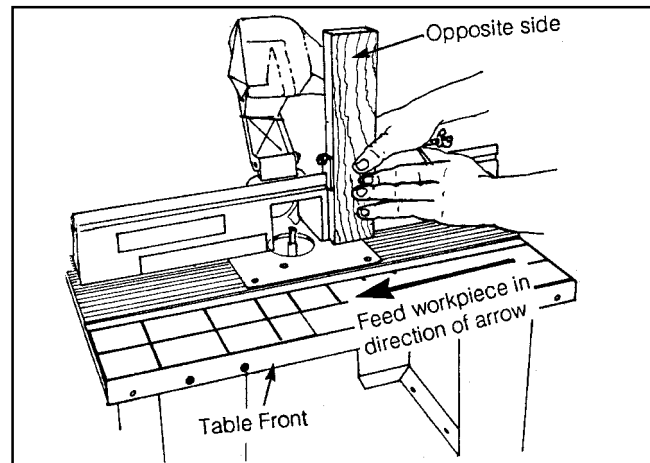

fig. Z.3

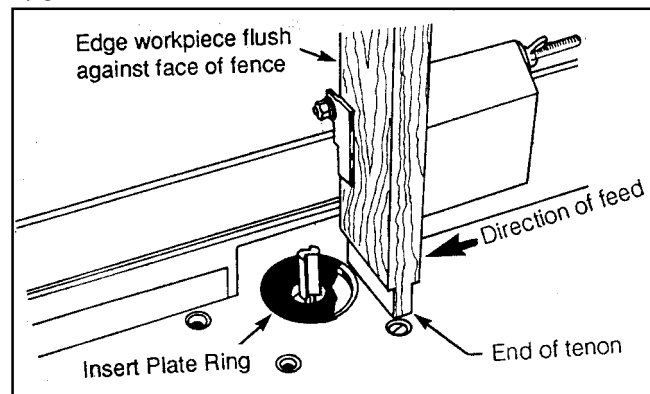
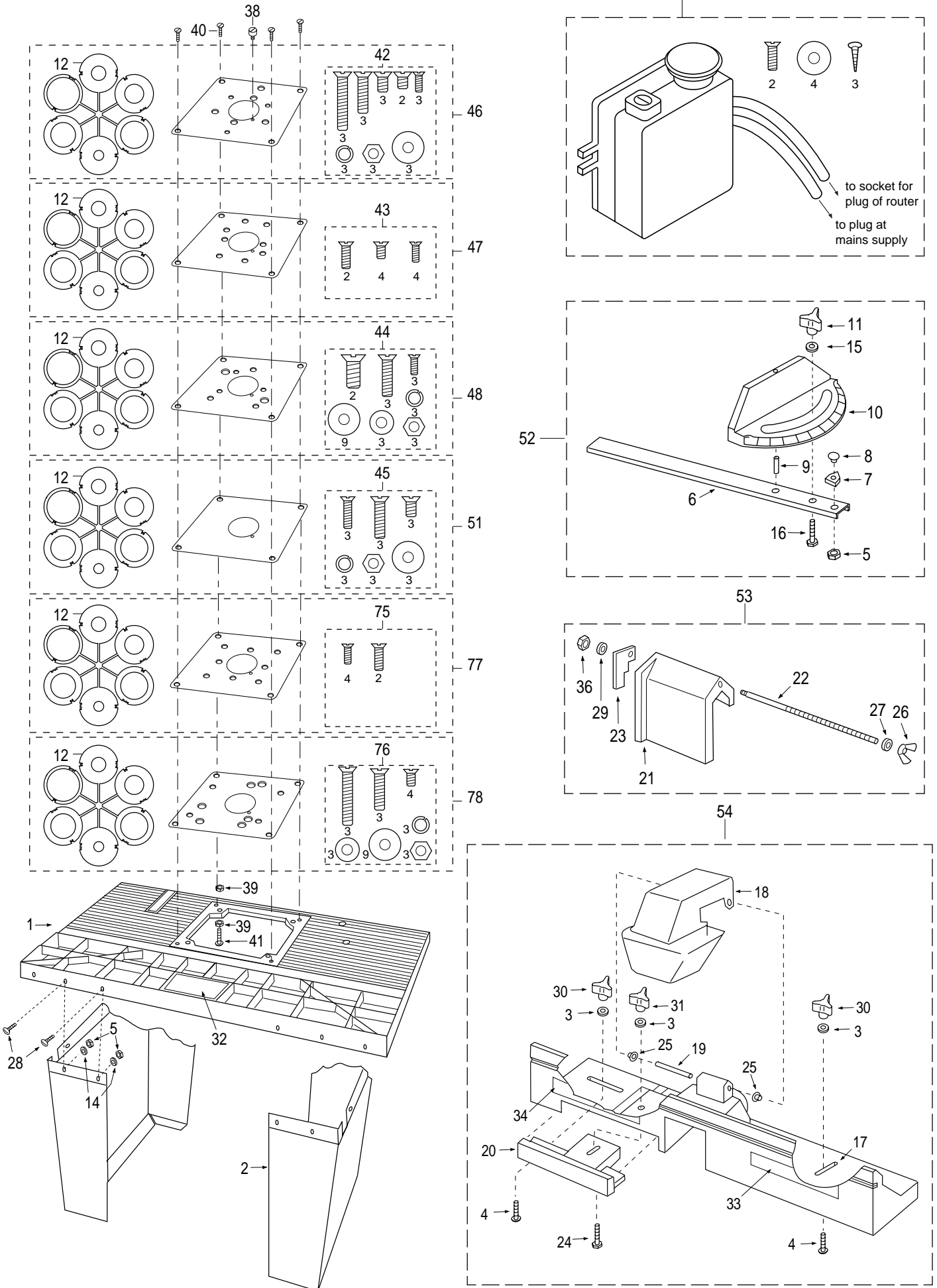
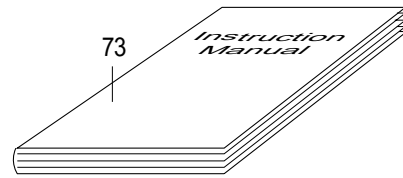
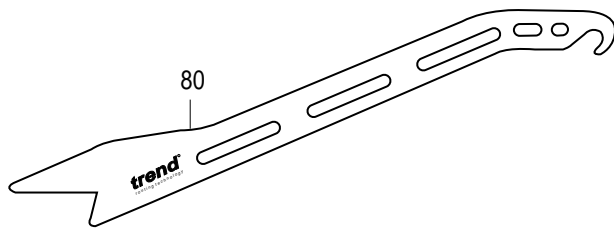

fig. Z.4

Spare Parts for Router Table Model CRT/A, CRT/B, CRT/C and CRT/X





Spare Parts for **Optional Accessories**

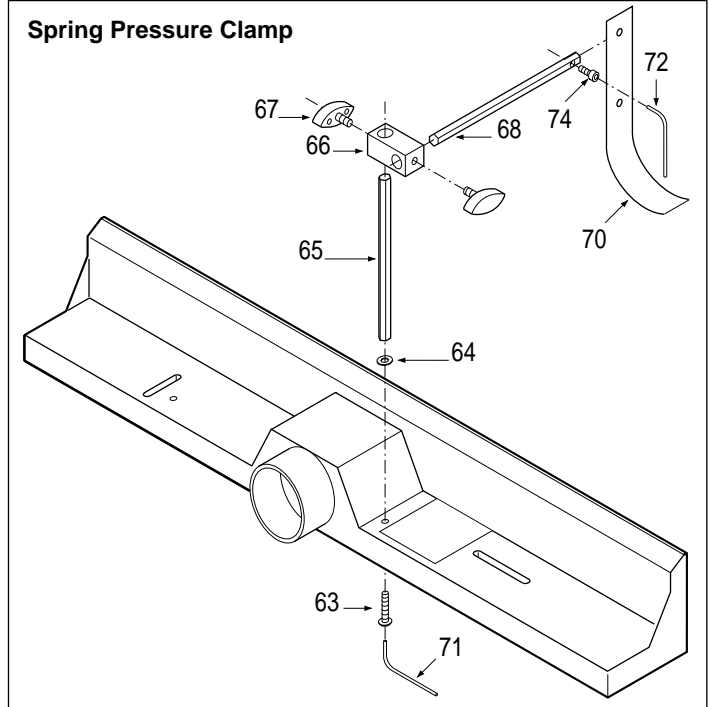
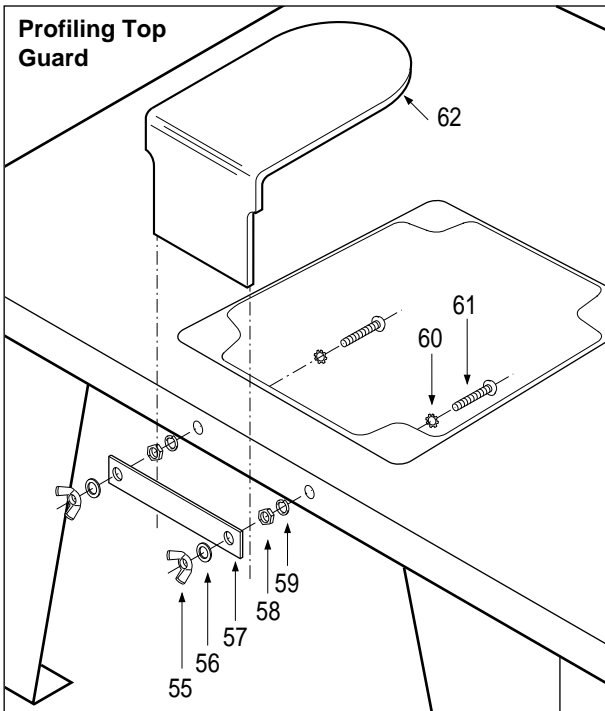

KEY	PART NO.	DESCRIPTION	KEY	PART NO.	DESCRIPTION
1	WP-CRT/01	Table Surface	41	WP-CRT/41	Insert Plate Adjustment Bolt
2	WP-CRT/02	Table Leg	42	WP-CRT/42	Fixing Pack for Insert Plate A
3	WP-CRT/03	Washer	43	WP-CRT/43	Fixing Pack for Insert Plate B
4	WP-CRT/04	Carriage Bolt	44	WP-CRT/44	Fixing Pack for Insert Plate C
5	WP-CRT/05	Nut	45	WP-CRT/45	Fixing Pack for Insert Plate X
6	WP-CRT/06	Mitre Bar	46	CRT/PLATE A	Insert Plate Set A
7	WP-CRT/07	Pointer	47	CRT/PLATE B	Insert Plate Set B
8	WP-CRT/08	Bolt	48	CRT/PLATE C	Insert Plate Set C
9	WP-CRT/09	Groove Pin	51	CRT/PLATE X	Insert Plate Set X
10	WP-CRT/10	Mitre Fence Head	52	WP-CRT/50	Mitre Fence Assembly-complete
11	WP-CRT/11	Small Size Knob	53	WP-CRT/51	Push Block Assembly-complete
12	WP-CRT/12	Insert Plate Ring Set	54	WP-CRT/52	Back Fence Assembly-complete
14	WP-CRT/14	Star Washer	55	WP-NUT/11	Wing Nut
15	WP-CRT/15	Washer	56	WP-WASH/09	Washer
16	WP-CRT/16	Securing Bolt	57	WP-CRT/57	Plate
17	WP-CRT/17	Back Fence	58	WP-NUT/05	Nut
18	WP-CRT/18	Retractable Safety Guard	59	WP-WASH/29	Spring Washer
19	WP-CRT/19	Pivot Pin	60	WP-WASH/39	Star Washer
20	WP-CRT/20	Workpiece Support	61	WP-SCW/16	M5 Bolt
21	WP-CRT/21	Push Block	62	WP-CRT/62	Perspex Guard
22	WP-CRT/22	Clamp Rod	63	WP-SCW/29	Bolt M6
23	WP-CRT/23	Clamp Plate	64	WP-WASH/50	Washer
24	WP-CRT/24	Workpiece Support Adjustment Bolt	65	WP-CRT/65	Vertical Pillar
25	WP-CRT/25	Push Nut	66	WP-CRT/66	Block
26	WP-CRT/26	Wing Nut	67	WP-KNB/01	Knob
27	WP-CRT/27	Flat Washer	68	WP-CRT/68	Horizontal Bar
28	WP-CRT/28	Dome Headed Screw	70	WP-CRT/70	Pressure Strip
29	WP-CRT/29	Spring Washer	71	WP-AK/04	Allen Key - 4mm A/F
30	WP-CRT/30	Large Size Knob	72	WP-AK/03	Allen Key - 3mm A/F
31	WP-CRT/31	Medium Size Knob	73	MANU/RT	Instruction Manual
32	WP-CRT/32	Label (Router Table)	74	WP-SCW/20	Retaining Screw
33	WP-CRT/33	Warning Label (Fence)	75	WP-CRT/75	Fixing Pack for Insert Plate D
34	WP-CRT/34	Label (Fence)	76	WP-CRT/76	Fixing Pack for Insert Plate E
36	WP-CRT/36	Hex Nut	77	CRT/PLATE D	Insert Plate Set D
38	WP-CRT/38	Lead-on Pin	78	CRT/PLATE E	Insert Plate Set E
39	WP-CRT/39	Nylock Nut	79	NVRS/230V	230 Volt No Volt Release Switch
40	WP-CRT/40	Insert Plate Retaining Bolt	80	PUSHSTICK/1	Plastic Pushstick

Spare parts are available from your Trend stockist. Prices exclude VAT and are subject to change.

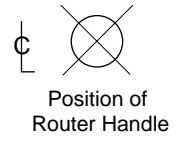
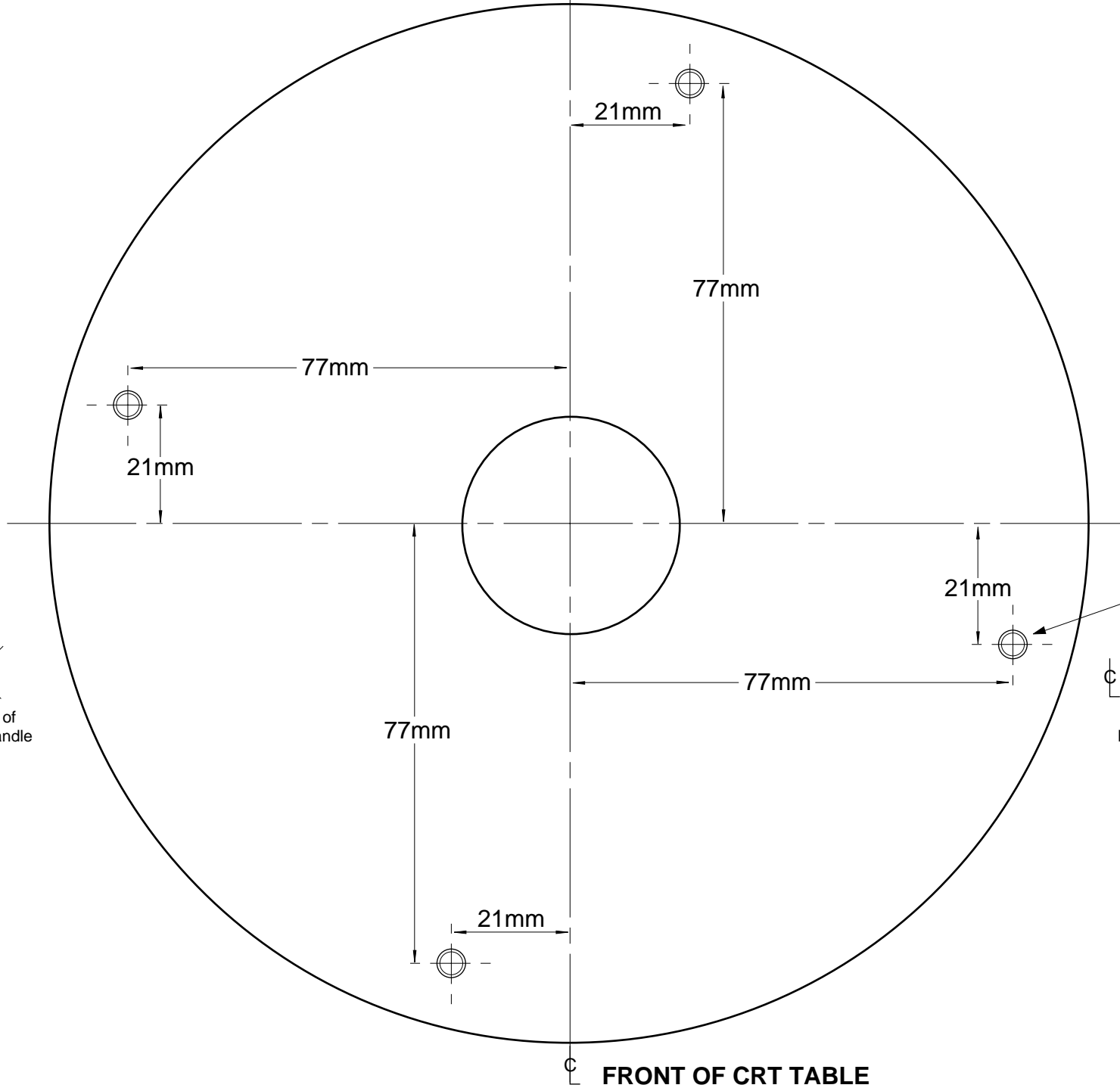

4 holes for
M5 M/C
screws

Plan for
HITACHI TR12
Router

Plan for
RYOBI R600, RE600
Routers

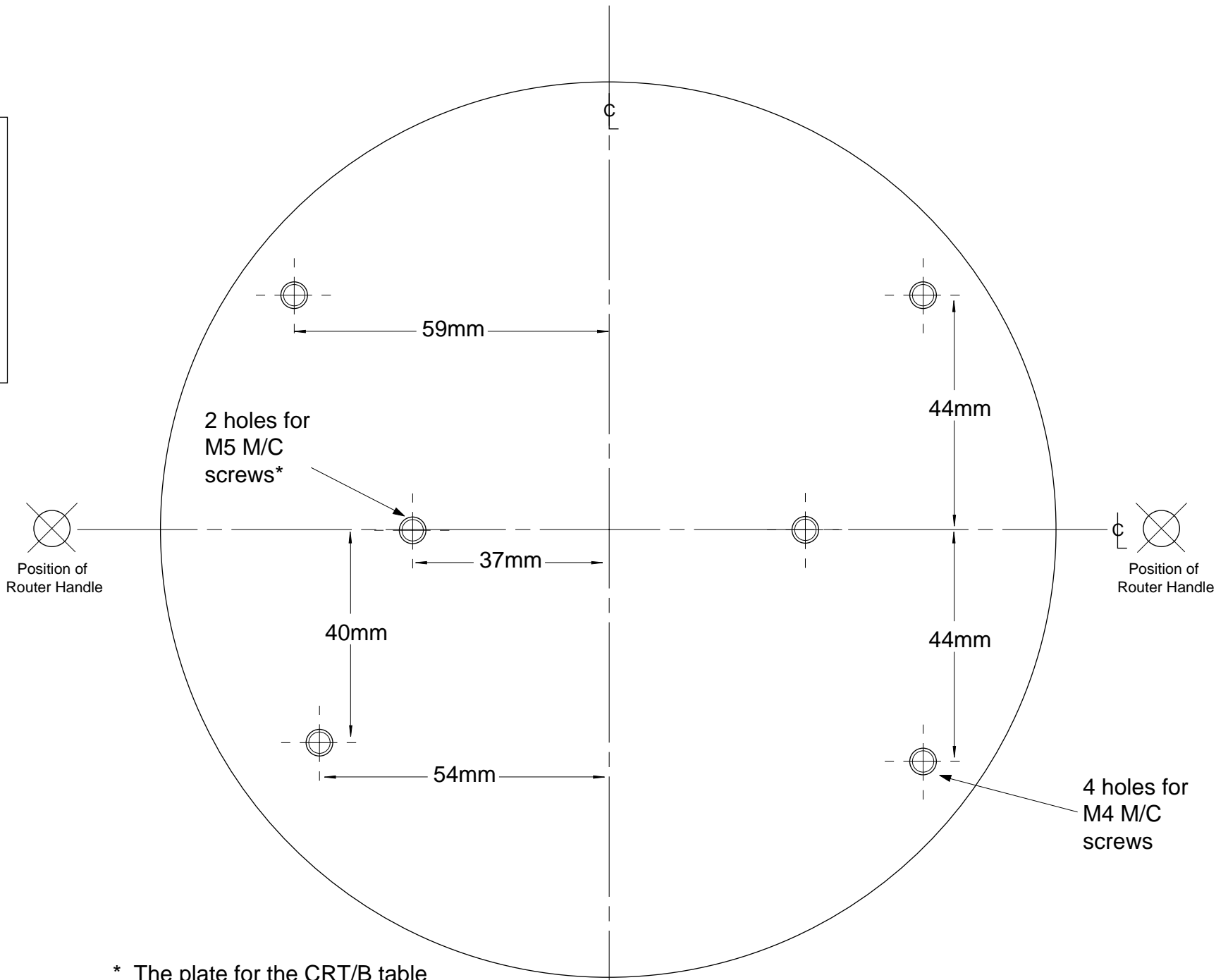

* The plate for the CRT/B table is pre-drilled to accept the two central fixings M5 M/C screw

FRONT OF CRT TABLE

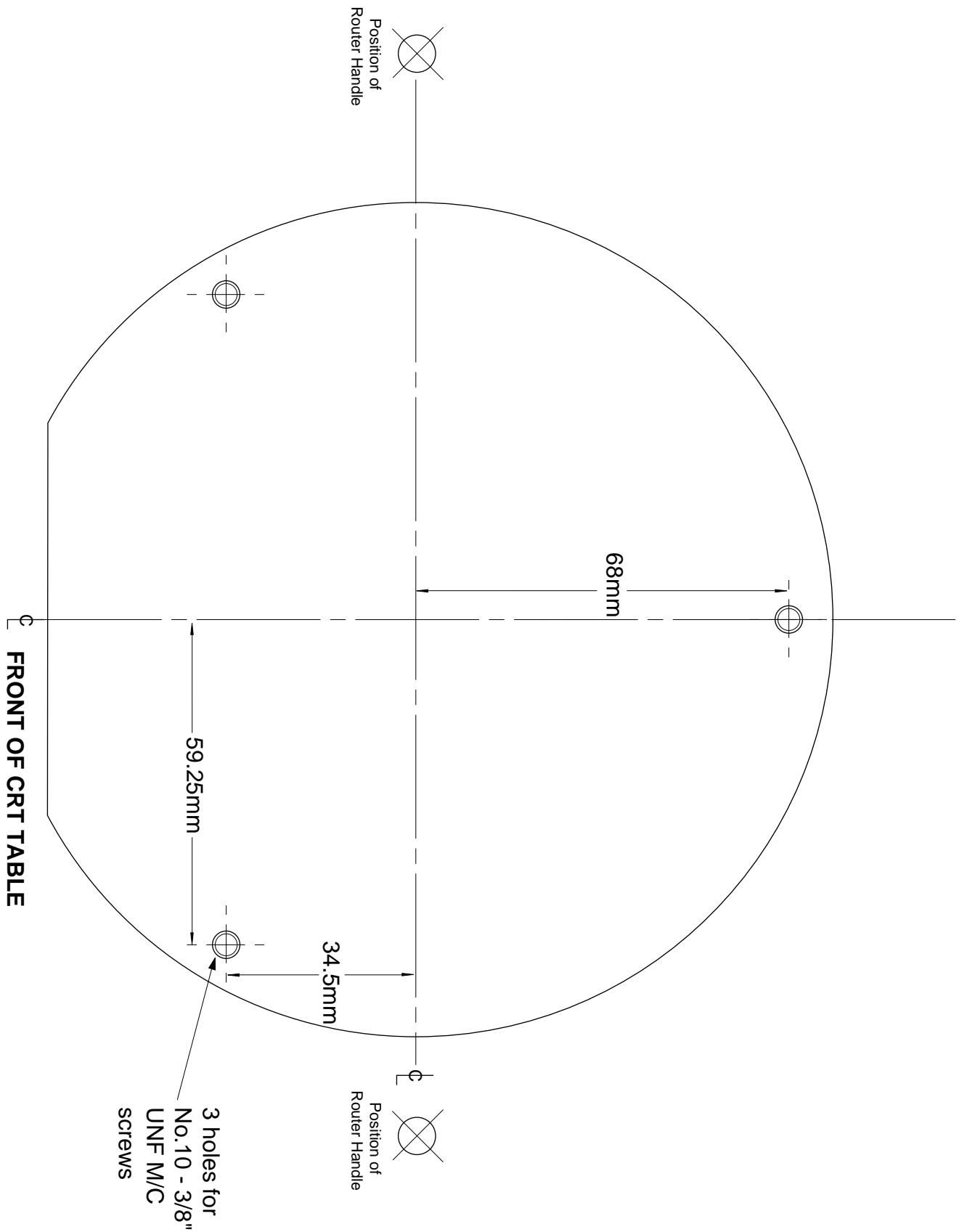

Plan for
SKIL 1835U, 1875U
Routers

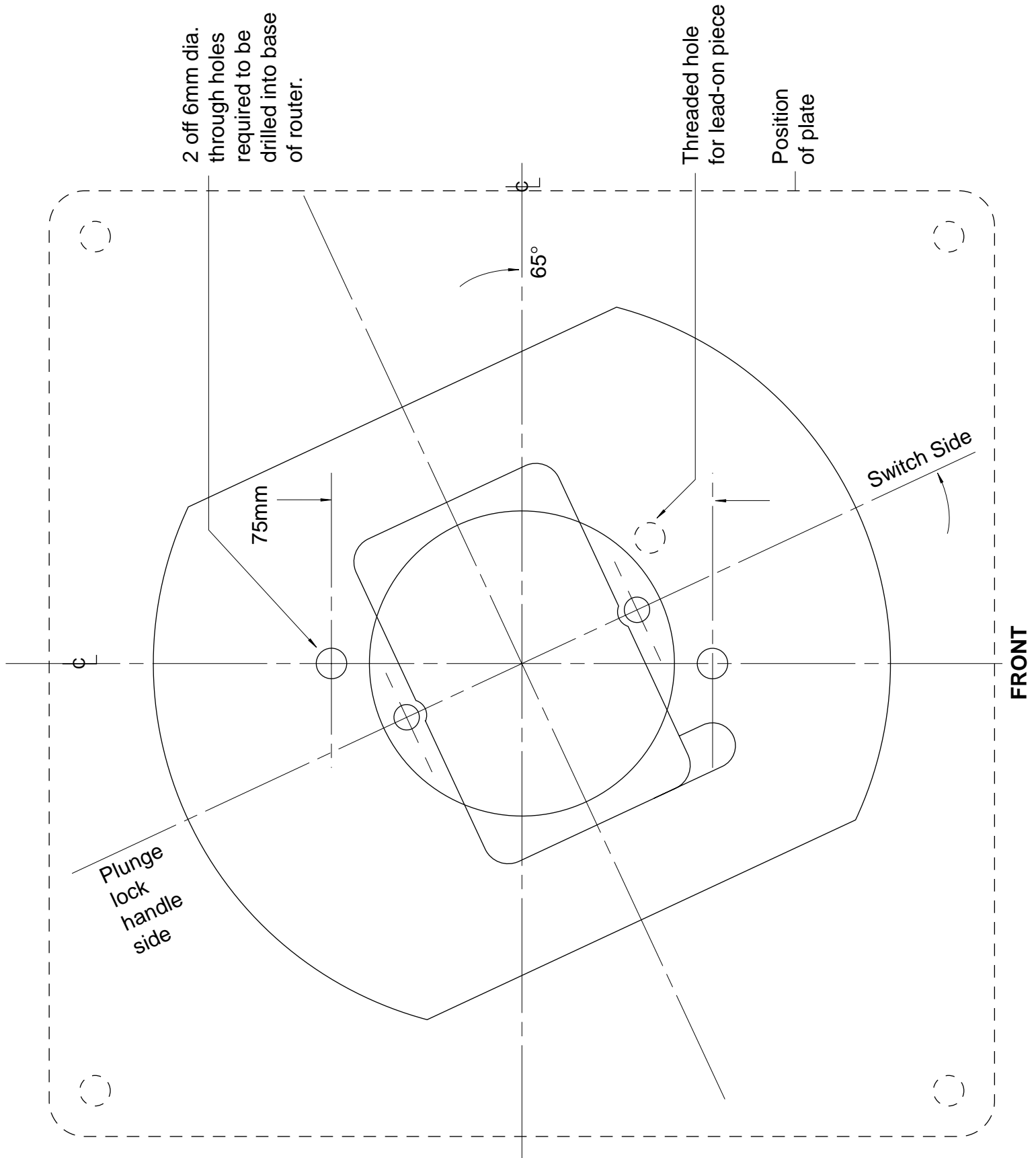

Underside view of Elu MOF 96(E) Mk1 base

Plan showing positions of holes required to be drilled in base of Elu MOF96(E) Mk1 and other similar makes

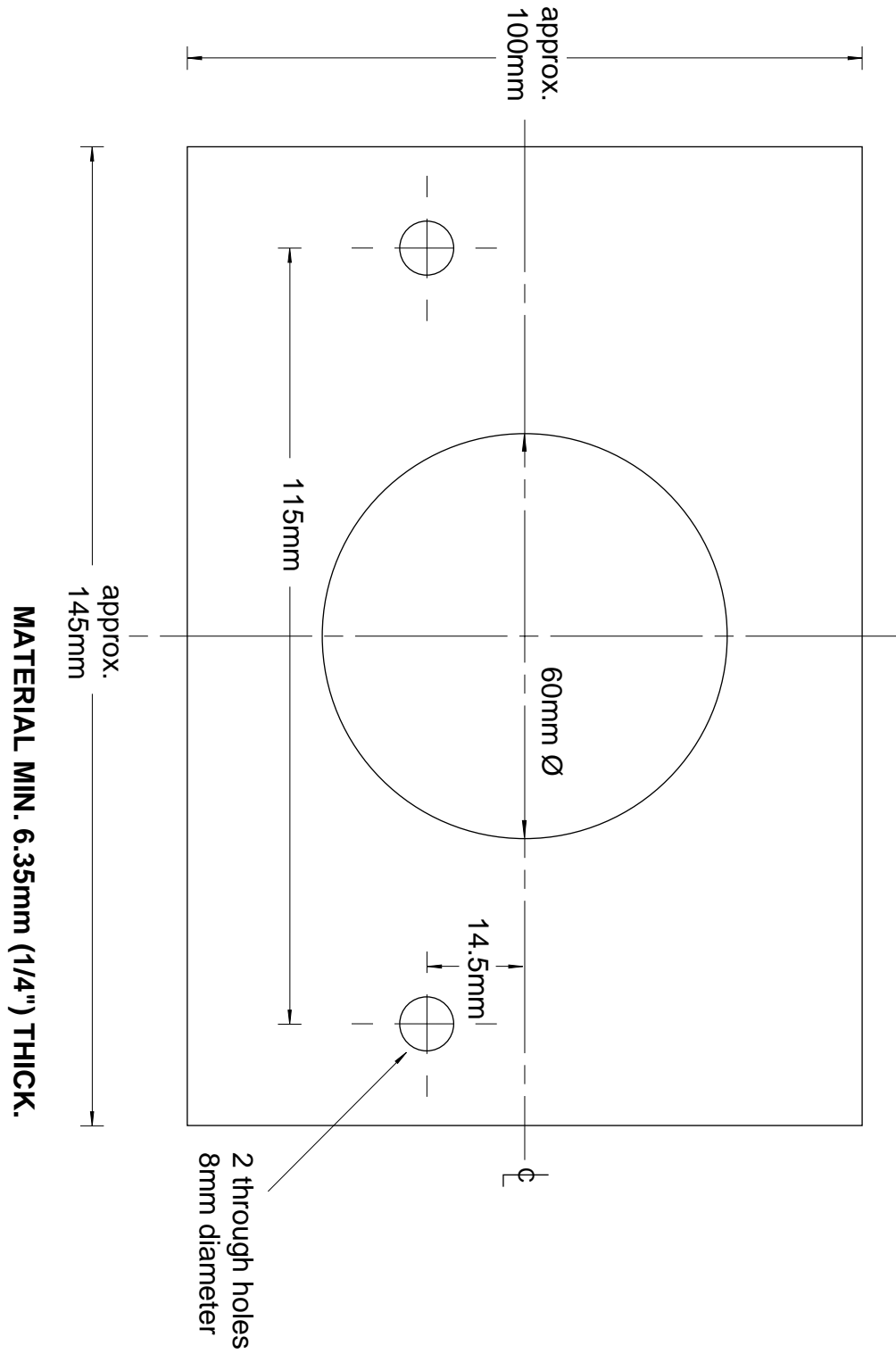

**Plan showing gasket
required for
ELU OF97(E)**

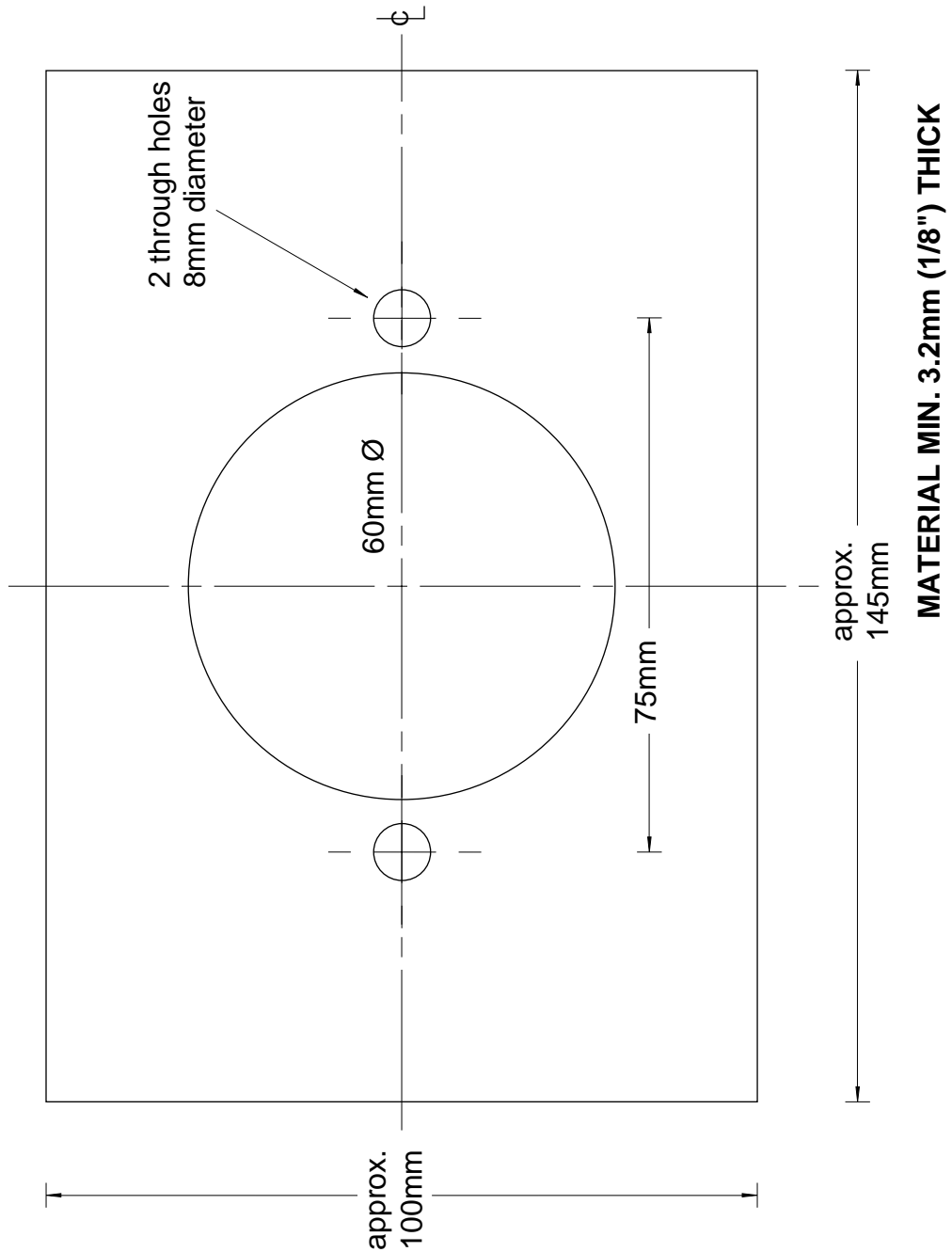

Plan showing gasket
required for
Bosch POF52, 400A,
500A & 600 ACE