

Operator's Manual



YARD VAC

Model No. 486.25012

DO NOT RETURN TO STORE
For Missing Parts or Assembly
Questions Call 1-866-576-8388

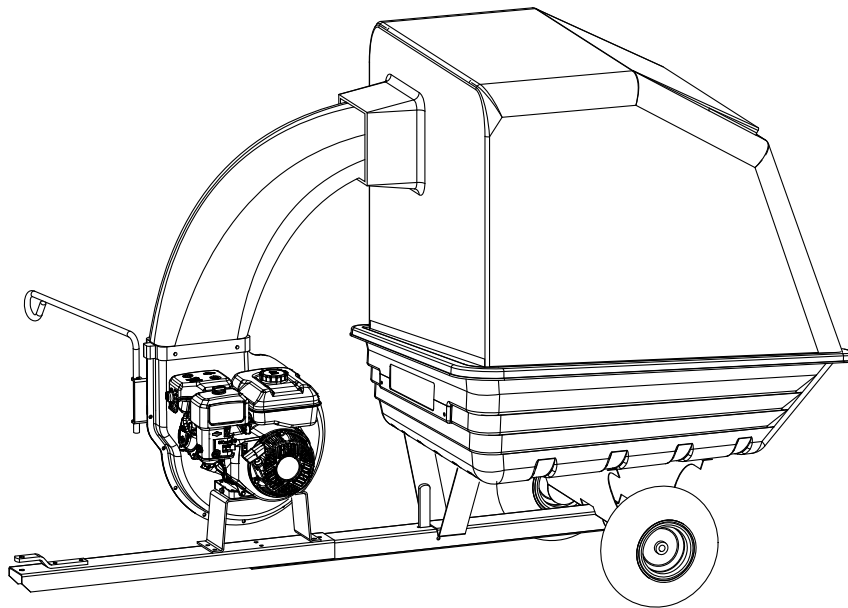

IMPORTANT! The engine is shipped without oil. Oil must be added before starting the engine. See Engine Maintenance on page 20 of this manual for instructions.

CAUTION:

Before using this product, read this manual and follow all Safety Rules and Operating Instructions.

- Safety
- Assembly
- Operation
- Maintenance
- Parts

Sears, Roebuck and Co., Hoffman Estates, IL 60179 U.S.A.
www.sears.com/craftsman

TABLE OF CONTENTS

WARRANTY	2	OPERATION.....	18
SAFETY.....	3	MAINTENANCE	20
ACCESSORIES AND ATTACHMENTS	5	STORAGE AND OPTIONAL USE	21
FULL SIZE HARDWARE CHART (CART).....	6	TROUBLESHOOTING.....	21
FULL SIZE HARDWARE CHART (ADAPTER).....	7	REPAIR PARTS	22-26
CARTON CONTENTS.....	8	PARTS ORDERING/SERVICE	BACK PAGE
ASSEMBLY.....	9		

WARRANTY

CRAFTSMAN FULL WARRANTY

FOR ONE YEAR from the date of purchase, this product is warranted against defects in material or workmanship. A defective product will receive free in-home repair or replacement if repair is unavailable.

WARRANTY SERVICE

For warranty coverage details to obtain free repair or replacement, call 1-800-659-5917 or visit the web site: www.craftsman.com

All of the above warranty coverage is void if this riding equipment is ever used while providing commercial services or if rented to another person.

This warranty covers ONLY defects in material and workmanship. Warranty coverage does NOT include:

- Expendable parts that can wear out from normal use within the warranty period, including but not limited to spark plugs, air cleaners, belts, and oil filters.
- Standard maintenance servicing, oil changes, or tune-ups.
- Tire replacement or repair caused by punctures from outside objects, such as nails, thorns, stumps, or glass.
- Tire or wheel replacement or repair resulting from normal wear, accident, or improper operation or maintenance.
- Repairs necessary because of operator abuse, including but not limited to damage caused impacting objects that bend the frame, axle assembly or crankshaft, or over-speeding the engine.
- Repairs necessary because of operator negligence, including but not limited to, electrical and mechanical damage caused by improper storage, failure to use the proper grade and amount of engine oil, failure to keep the product clear of flammable debris, or failure to maintain the equipment according to the instructions contained in the operator's manual.
- Engine (fuel system) cleaning or repairs caused by fuel determined to be contaminated or oxidized (stale). In general, fuel should be used within 30 days of its purchase date.
- Normal deterioration and wear of the exterior finishes, or product label replacement.

This warranty gives you specific legal rights, and you may also have other rights which vary from state to state.

Sears Brands Management Corporation, Hoffman Estates, IL 60179

<p>The model number and serial numbers will be found on a decal attached to the Yard Vac. You should record both the serial number and the date of purchase and keep in a safe place for future reference.</p>	<table><tr><td>MODEL NUMBER:</td><td>486.25012</td></tr><tr><td>SERIAL NUMBER:</td><td>_____</td></tr><tr><td>DATE OF PURCHASE:</td><td>_____</td></tr></table>	MODEL NUMBER:	486.25012	SERIAL NUMBER:	_____	DATE OF PURCHASE:	_____
MODEL NUMBER:	486.25012						
SERIAL NUMBER:	_____						
DATE OF PURCHASE:	_____						



SAFETY



Any power equipment can cause injury if operated improperly or if the user does not understand how to operate the equipment. Exercise caution at all times when using power equipment.

- Read and follow all instructions in this manual before attempting to assemble or operate this equipment. Failure to comply with these instructions may result in personal injury. Keep this manual in a safe place for future reference and for ordering replacement parts.
- Read this operating and service instruction manual carefully. Be thoroughly familiar with the controls and proper use of this power vacuum.
- Read the vehicle owners manual and vehicle safe operation rules before using this equipment.
- Never allow children under 16 to operate this Vac System. Children 16 years and older should only operate under close parental supervision.
- DO NOT allow anyone to operate this equipment without proper instructions.
- DO NOT allow passengers to ride on this equipment or the towing vehicle.
- Keep the area of operation clear of others, particularly small children and pets.
- Check fuel before starting engine. Do not fill fuel tank indoors, while engine is running or while engine is hot. Wipe off any spilled fuel before starting engine.
- Engine and muffler get hot. Do not touch! To avoid fire hazard, keep clean of debris and other accumulations.
- Never store Vac System with fuel in tank. Allow engine to cool before storing in any enclosure.
- Do not change engine governor settings.
- Do not operate engine if air cleaner or cover is removed except for adjustment. Removal of these parts could create a fire hazard.
- Keep hands, feet, face, long hair and clothing out of inlet and discharge area. There are ROTATING BLADES inside these openings.
- Before cleaning, repairing or inspecting, make certain all moving parts come to a complete stop. Disconnect spark plug wire and keep wire away from plug to prevent accidental starting. Keep throttle control lever in stop position.
- If the Vac System should become blocked with debris at any point, shut engine off and wait until the impeller comes to a complete stop before attempting to remove the obstruction. Disconnect spark plug wire to prevent accidental starting.
- If the cutting mechanism strikes a foreign object, or if your Yard Vac should start to vibrate abnormally, stop the engine immediately, disconnect spark plug wire and move the wire away from the spark plug. Allow the machine to stop and take the following steps.
 - a. Inspect for damage.
 - b. Repair or replace any damaged parts.
 - c. Check for loose parts and tighten to assure continued safe operation.
- Check all bolts for tightness at frequent intervals to help insure safe operation.
- Check top cover frequently for wear. Replace if worn or damaged.
- Never operate Yard Vac unless deck adapter, hose, hose adapter (nozzle), discharge chute (elbow), and top cover are properly attached in their place.
- Do not remove top cover or attempt to empty contents of cart while engine is running.
- Never attempt to change hose adapter (nozzle) or to install remote hose attachment when engine is running.
- Keep all shields and guards (e.g. discharge chute (elbow) and hose adapter (nozzle) in place and securely attached.
- Always wear safety glasses or other suitable eye protection when operating or maintaining this equipment.
- Do not stand behind cart in exhaust discharge area while engine is running.
- Do not operate this equipment while intoxicated or while taking drugs or medication that impairs the senses or reactions.
- When using this equipment, start the vehicle transmission in first (low) gear and then gradually increase speed only as conditions permit.
- Operate this equipment at reduced speed on rough terrain, along creeks and ditches and on slopes to prevent tipping or loss of control. Do not drive too close to a creek or ditch.
- Vehicle braking and stability are affected by the addition of this equipment. Do not fill the Yard Vac to its full capacity without checking the capability of the towing vehicle to safely pull and stop with Yard Vac attached.
- Before operating on any grade (hill) refer to the safety rules in the vehicle owner's manual concerning safe operation on slopes. Also refer to the SLOPE GUIDE on page 27 of this owner's manual. Do not operate on slopes in excess of 10 degrees. **STAY OFF STEEP SLOPES!**
- Follow the maintenance instructions outlined in this manual.



Look for this symbol to point out important safety precautions. It means — **Attention!! Become alert!! Your safety is involved.**



DANGER: This Vac System was built to be operated according to the rules for safe operation in this manual. As with any type of power equipment, carelessness or error on the part of the operator can result in serious injury. This unit is capable of amputating fingers and hands and throwing objects. Failure to observe the safety instructions could result in serious injury or death.

WARNING

TO AVOID SERIOUS INJURY

- Read Owner's Manual and all safety labels on machine before starting and using machine.
- Do Not remove top cover or attempt to empty contents of cart while engine is running.
- Do Not stand behind cart in exhaust discharge area while engine is running.
- Keep hands, feet, face, long hair and clothing out of chipper inlet, vac inlet, and discharge area. There are **ROTATING BLADES** inside these openings.
- Wear approved safety glasses and gloves. Avoid loose fitting clothes.
- Keep the area of operation clear of all persons, particularly small children and pets.
- Keep all shields and guards (e.g. upper chipper chute extension, discharge chute, nozzle assembly) in place and securely attached.
- Check discharge boot frequently for wear. Replace if worn or damaged.
- If unit becomes clogged or jammed, shut off engine right away. Do Not attempt to clear clog or jam with engine running.
- Muffler and engine get hot and can cause burns. Do Not Touch. To avoid a fire hazard, keep leaves, grass and other combustible debris off hot muffler and engine.
- Do Not attempt to remove or attach vac nozzle or optional Hose Kit with engine running.
- Do Not operate unit unless nozzle or optional Hose Kit is secured in place.
- Do Not fill gas tank while engine is running. Allow engine to cool at least 2 minutes before refueling.



DANGER

HAZARDOUS ROTATING BLADES INSIDE. KEEP HANDS AWAY FROM ALL OPENINGS. DO NOT REMOVE OR ATTACH HOSE, HOSE ADAPTER, ELBOW OR OPTIONAL HOSE KIT WHEN ENGINE IS RUNNING!



WARNING

This unit is equipped with an internal combustion engine and should not be used on or near unimproved forest-covered, or grass-covered land unless the engine's exhaust system is equipped with a spark arrester meeting applicable local or state laws (if any). If a spark arrester is used, it should be maintained in effective working order by the operator.

In the State of California the above is required by law (Section 4442 of the California Public Resources Code). Other states may have similar laws. Federal laws apply on federal lands. A spark arrester muffler is available at your nearest engine authorized service center.

ACCESSORIES AND ATTACHMENTS

These accessories were available when the unit was purchased. They are also available at most Sears retail outlets and service centers. Most Sears stores can order repair parts for you when you provide the model numbers of your tractor and Yard Vac System.

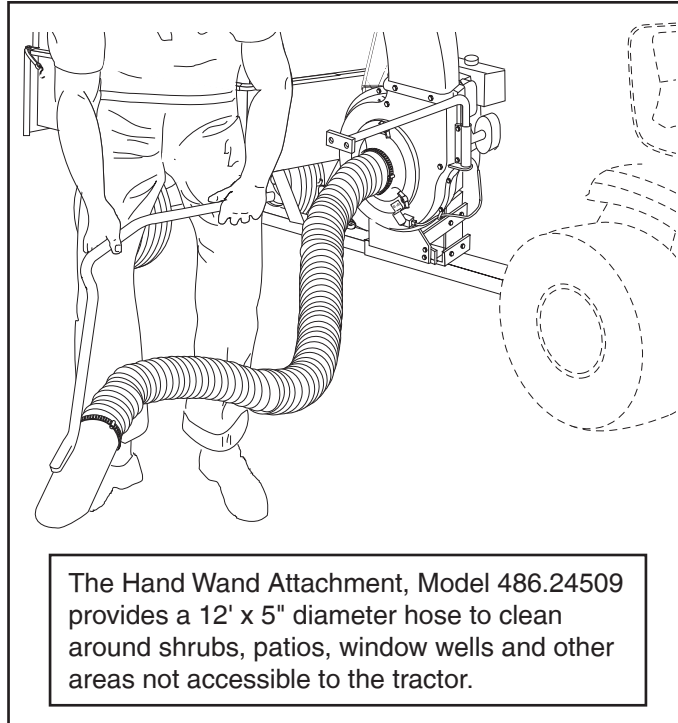

FULL SIZE HARDWARE CHART (CART)

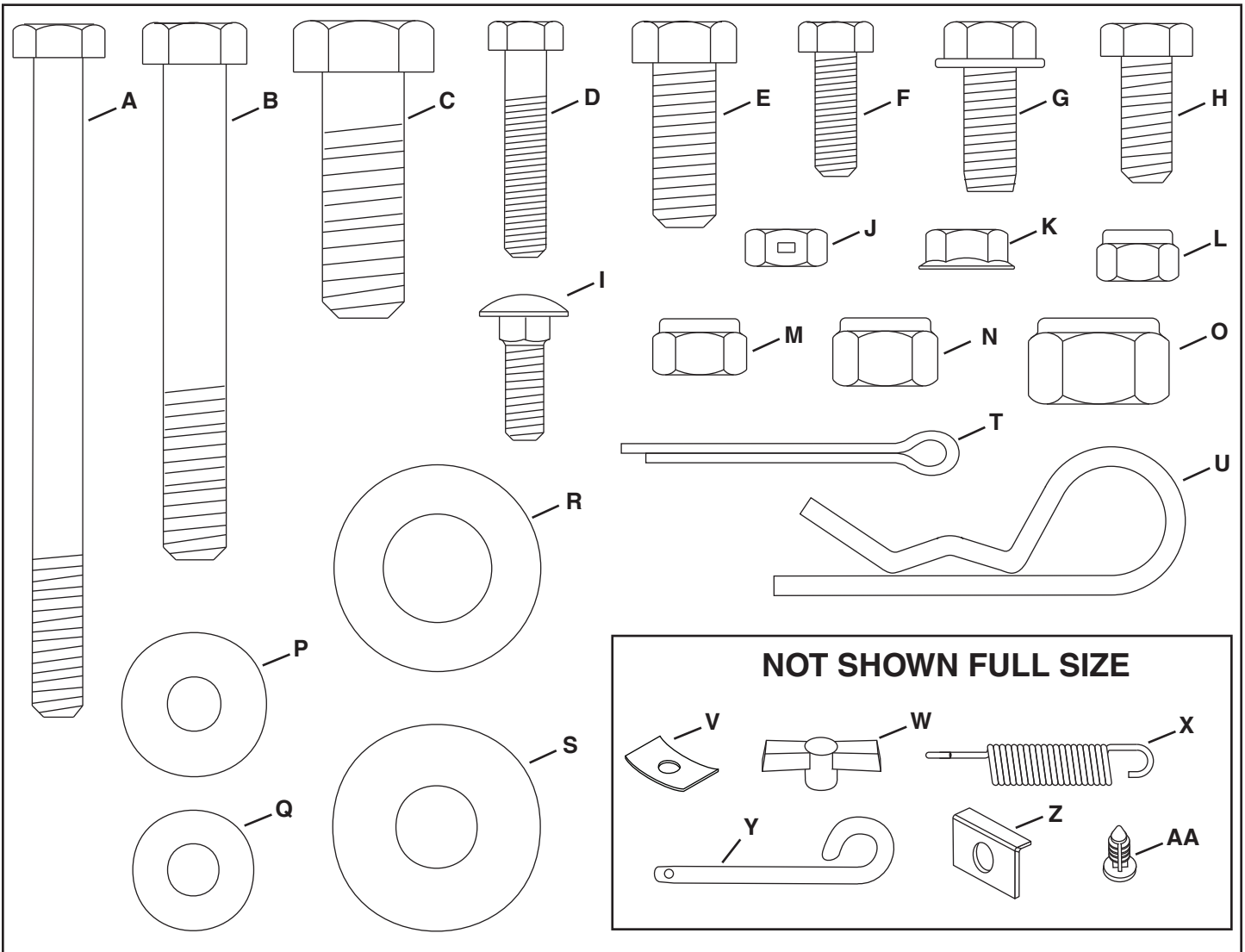

REF. NO.	PART NO.	QTY.	DESCRIPTION	REF. NO.	PART NO.	QTY.	DESCRIPTION
A	47407	1	Hex Bolt, 5/16-18 x 4"	N	HA21362	9	Nylock Nut, 3/8-16
B	43574	5	Hex Bolt, 3/8-16 x 3"	O	712-3083	1	Nylock Nut, 1/2-13
C	43351	1	Hex Bolt, 1/2-13 x 1-1/4"	P	1543-69	4	Nylon Washer
D	1509-90	4	Hex Bolt, 1/4-20 x 1-1/4"	Q	43088	2	Washer, 1/4" Std.
E	43001	4	Hex Bolt, 3/8-16 x 1"	R	R19212016	4	Washer, 5/8"
F	43012	10	Hex Bolt, 1/4-20 x 3/4"	S	43352	1	Flat Washer, 7/16"
G	47630	4	Hex Bolt, 5/16-18 x 3/4" Thread Forming	T	43010	2	Cotter Pin
H	43182	8	Hex Bolt, 5/16-18	U	43343	1	Hair Cotter Pin
I	44950	5	Carriage Bolt, 1/4-20 x 3/4"	V	41518	5	Tinnerman Nut, 1/4-20
J	43013	6	Lock Nut, 1/4-20	W	712-0421	3	Wing Nut, 5/16-18
K	47598	11	Nut, Hex Flange 1/4-20	X	HA20186	1	Spring
L	47189	4	Nylock Nut, 1/4-20	Y	23353	1	Hitch Pin
M	47810	9	Nylock Nut, 5/16-18	Z	25910	2	Axle Clip
				AA	48402	2	Plug, Plastic

FULL SIZE HARDWARE CHART (ADAPTER)

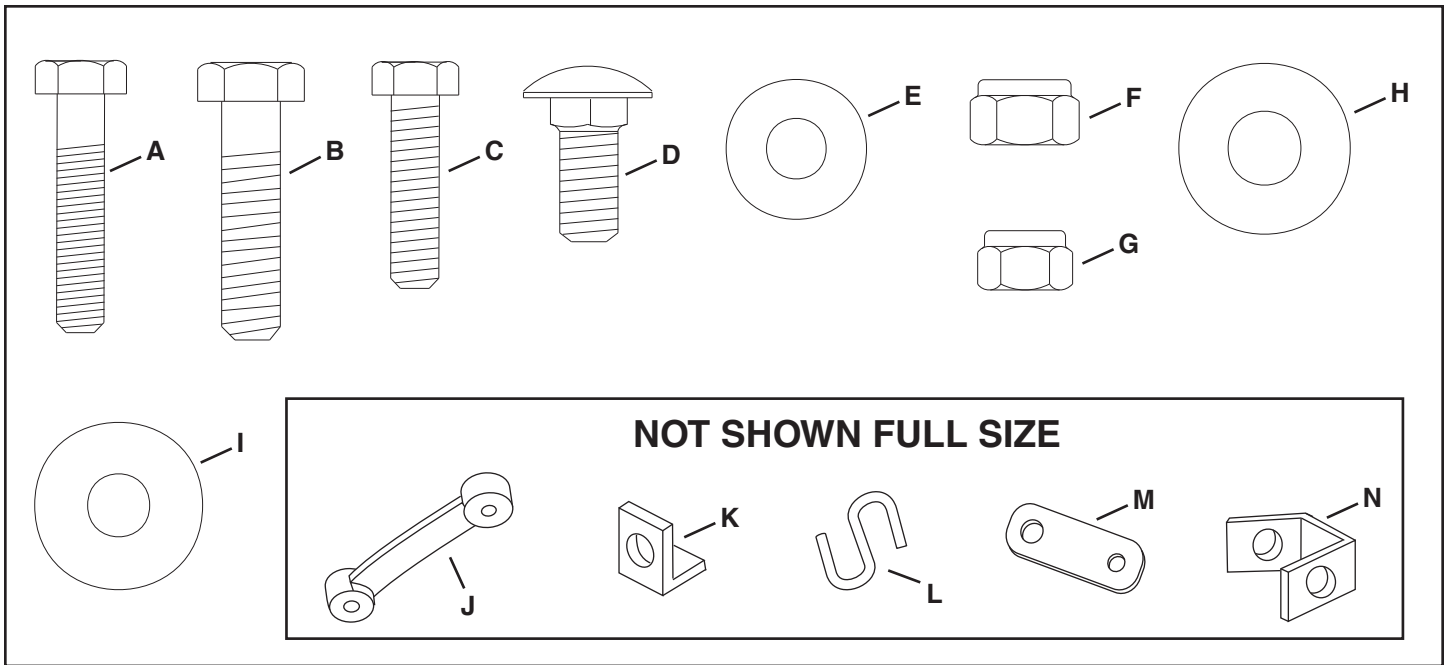

REF. NO.	PART NO.	QTY.	DESCRIPTION	REF. NO.	PART NO.	QTY.	DESCRIPTION
A	1509-90	3	Hex Bolt, 1/4-20 x 1-1/4"	H	43081	12	Washer, 5/16" Std.
B	43840	2	Hex Bolt, 5/16-18 x 1-1/4"	I	1543-69	5	Nylon Washer
C	43661	4	Hex Bolt, 1/4-20 x 1"	J	44850	2	Tarp Strap
D	43080	2	Carriage Bolt, 5/16" x 3/4"	K	23826	1	Angle Bracket
E	43088	9	Washer, 1/4" Std.	L	44849	2	"S" Hook
F	47810	3	Nylock Nut, 5/16-18	M	23825	1	Mounting Strap
G	47189	5	Nylock Nut, 1/4-20	N	23827	1	Mounting Bracket

CARTON CONTENTS

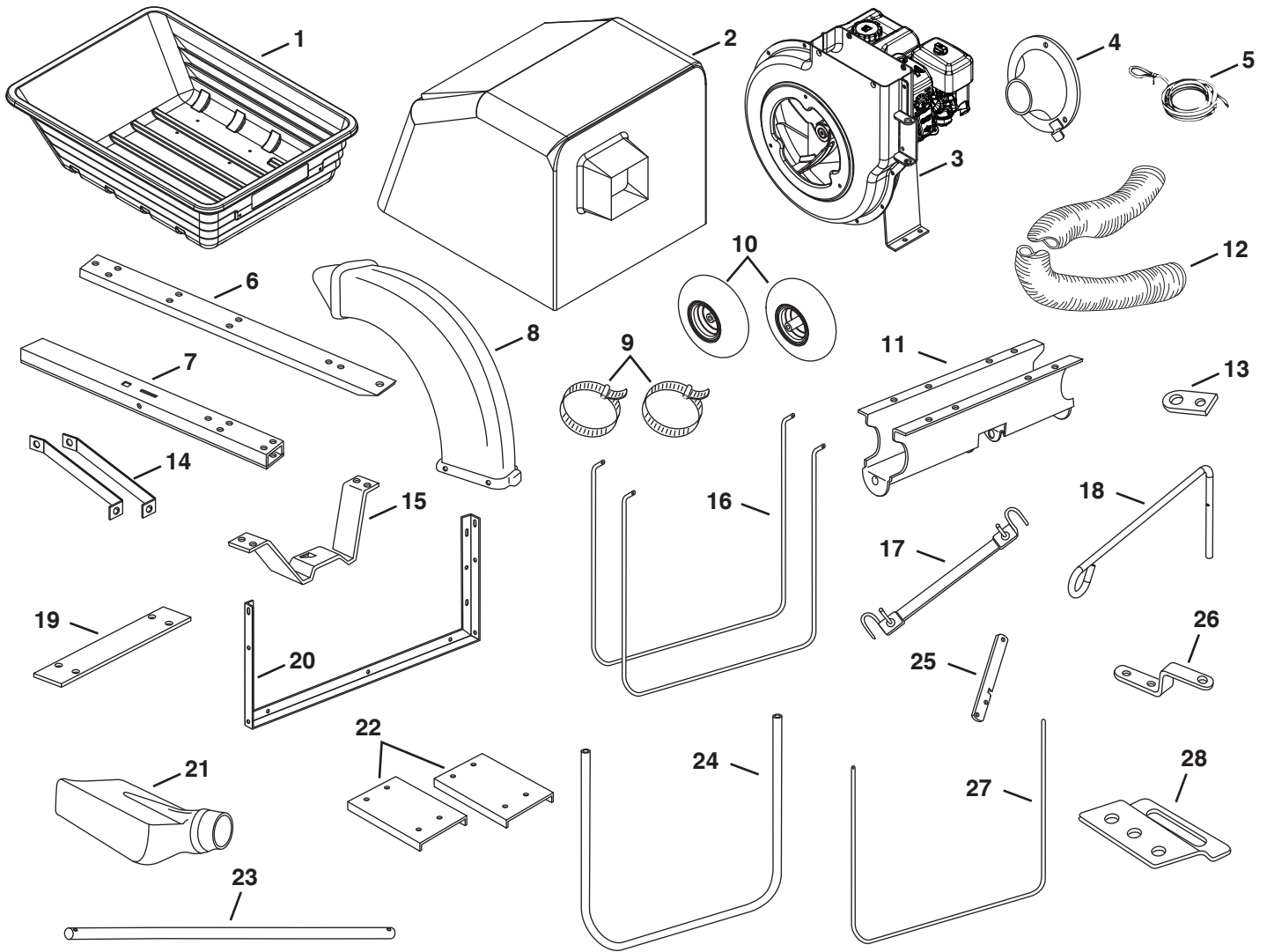

REF. NO.	PART NO.	QTY.	DESCRIPTION	REF. NO.	PART NO.	QTY.	DESCRIPTION
1	48791	1	Cart Tray	15	24497	1	Latch Stand Bracket
2	40343	1	Cart Cover	16	49873	2	Lower Support Rod
3	41310	1	Engine	17	43790	1	Tarp Strap, 25"
4	43791	1	Hose Adapter	18	49974	1	Hose Hanger Rod
5	65518	1	Rope, 36"	19	24386	1	Latch Stand Plate
6	25742	1	Front Tongue	20	27144	1	Top Support Angle
7	65442	1	Rear Tongue	21	43830	1	Deck Adapter
8	46420	1	Elbow w/ Deflector	22	25875	2	Cart Bed Brace
9	43793	2	Hose Clamp	23	26008	1	Axle
10	48497	2	Wheel	24	25874	1	Front Support Tube
11	24527	1	Wheel Support	25	25010	1	Latch Lock Lever
12	41882	1	Hose	26	23475	1	Hitch Bracket
13	23540	1	Hitch Plate	27	49872	1	Front Support Rod
14	25876	2	Brace	28	23560	1	Adapter Bracket (Deck)

ASSEMBLY

This unit is shipped **WITHOUT GASOLINE or OIL**. After assembly, see separate engine manual for proper fuel and engine oil recommendations.

TOOLS REQUIRED FOR ASSEMBLY

- (1) Screwdriver
- (1) Pliers
- (2) 7/16" Wrenches
- (2) 1/2" Wrench
- (2) 9/16" Wrenches
- (2) 3/4" Wrenches (only if figure 12 on page 12 is used)

REMOVAL OF PARTS FROM CARTONS

- Remove the hardware packs and all loose parts from the cartons.
- Lay out and identify parts shown in carton contents.
- Lay out and identify parts in the hardware packs. Keep contents of each hardware package separate.

CART ASSEMBLY

- Assemble latch lock lever to rear tongue using 5/16" x 4" hex bolt and 5/16" nylock nut. Tighten nut until snug against side of rear tongue. See figure 1A.
- Attach the spring to the hole in the latch lock lever and the hole in the tongue. See figure 1B.

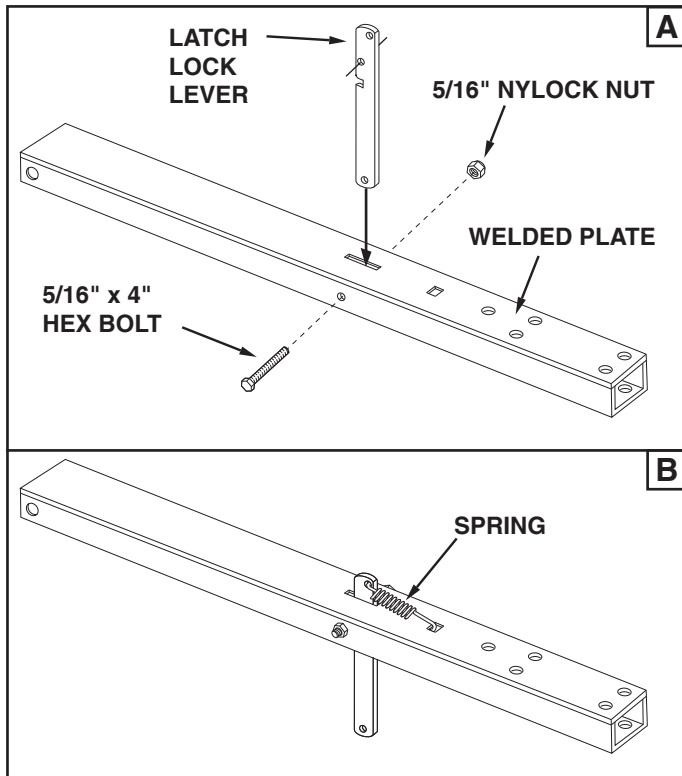

FIGURE 1

- Attach the hitch bracket to the front tongue using two 3/8" x 1" bolts and 3/8" nylock nuts. See figure 2.
- Assemble the front tongue on top of the rear tongue using three 3/8" x 3" hex bolts and 3/8" nylock nuts. See figure 2.
- Install the hitch pin and the hair cotter pin in the hitch bracket and front tongue. See figure 2.

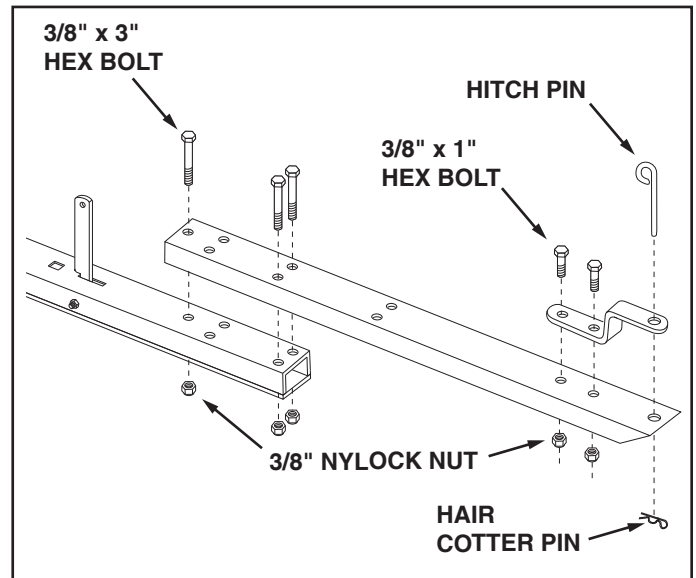

FIGURE 2

- Assemble the rear tongue to the wheel support by sliding the axle through the holes in the tongue and wheel support as shown in figure 3.

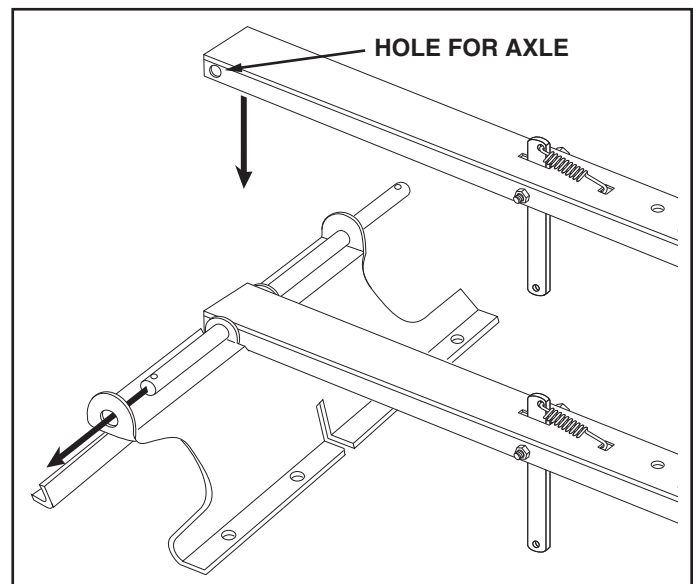

FIGURE 3

- Assemble an axle clip, a wheel and a 5/8" washer onto each end of the axle. Assemble a second 5/8" washer onto each end of the axle if space allows. Secure both wheels in place using two cotter pins. See figure 4.

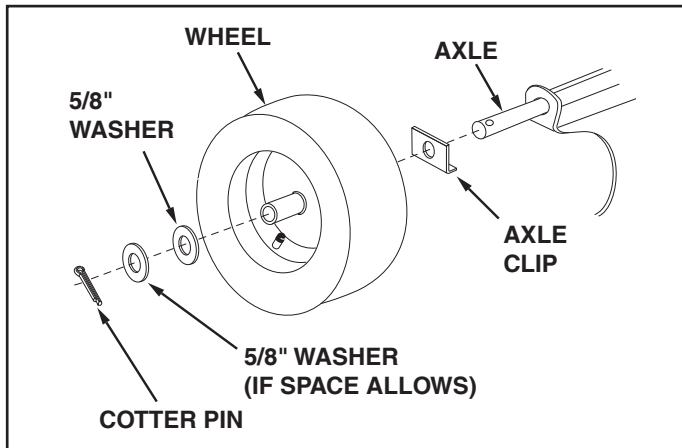

FIGURE 4

- Assemble the latch stand plate and latch stand bracket (with alignment tab toward rear of cart) to the cart tray using four 1/4" x 3/4" hex bolts and 1/4" nylock nuts. Tighten nuts after all bolts are in place. See figure 5.

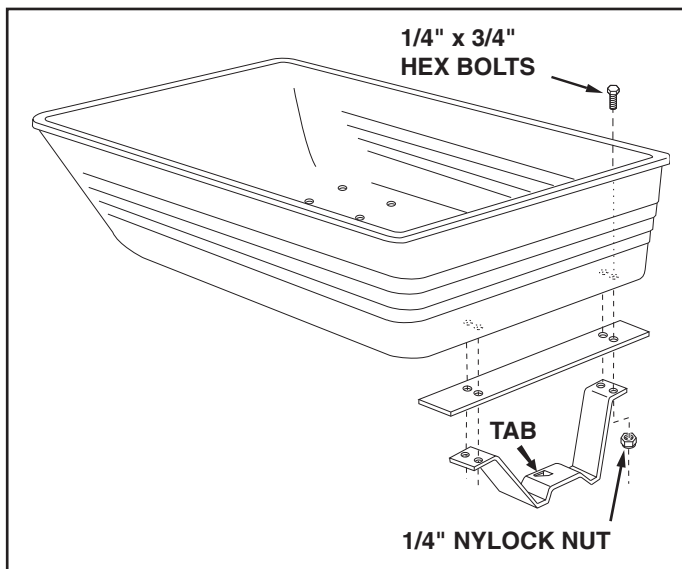

FIGURE 5

- Place the cart bed braces and the cart tray onto the wheel support. Secure latch stand bracket underneath the tongue's latch lock lever. See figure 6.
- Assemble the cart tray and cart bed braces to the wheel support using eight 5/16" x 3/4" hex bolts and 5/16" nylock nuts. Tighten nuts after all bolts are in place. See figure 6.

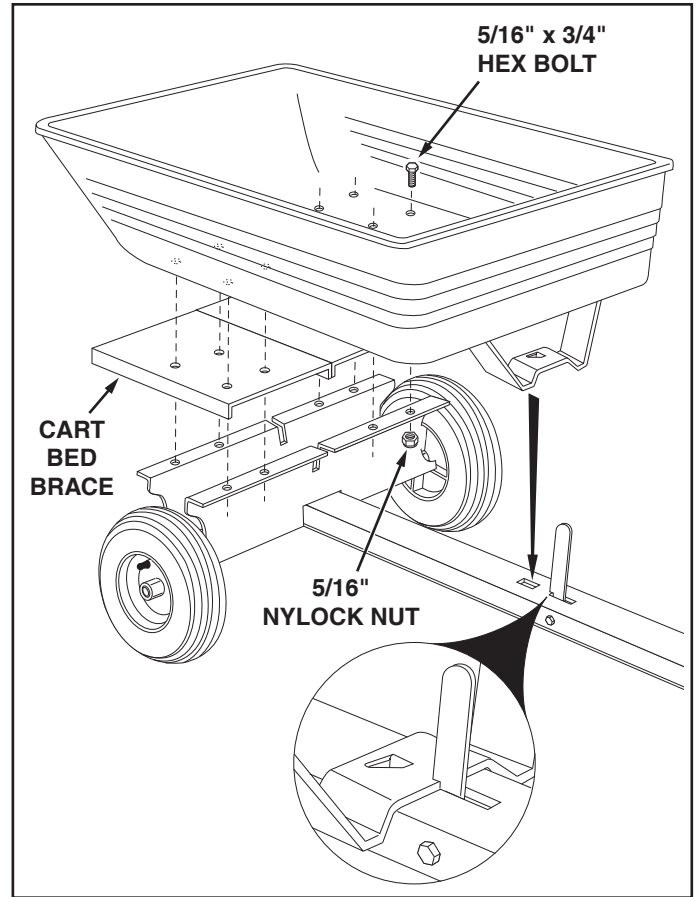

FIGURE 6

- Attach the engine mounting plate to the tongues using two 3/8" x 3" hex bolts in the back holes, two 3/8" x 1" hex bolts in the front holes and four 3/8" nylock nuts. See figure 7.

HINT: For easier assembly, support the rear tongue with a block of wood.

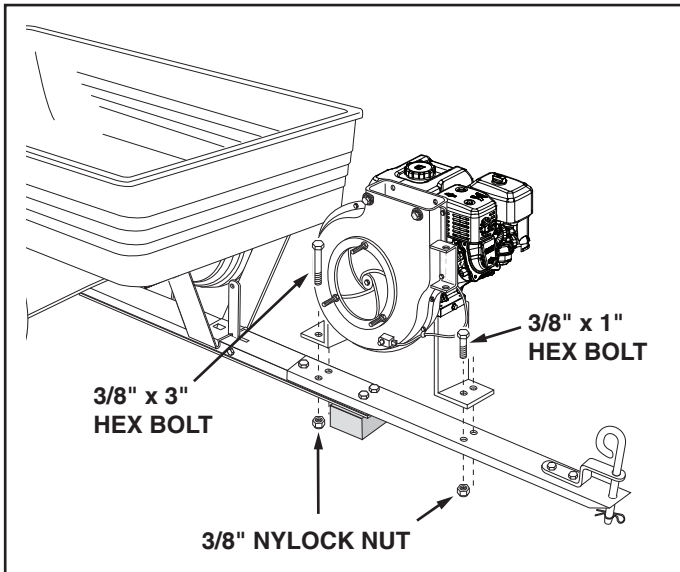

FIGURE 7

- Attach the plastic elbow to the top of the engine housing using four 5/16" x 3/4" hex bolts (self tapping) and nylon washers. See figure 8.

HINT: Push in on hex bolts as you tighten to form threads.

- Connect the hose adapter to the engine housing by fastening three wing nuts to the pre-assembled bolts in the engine housing. See figure 8.

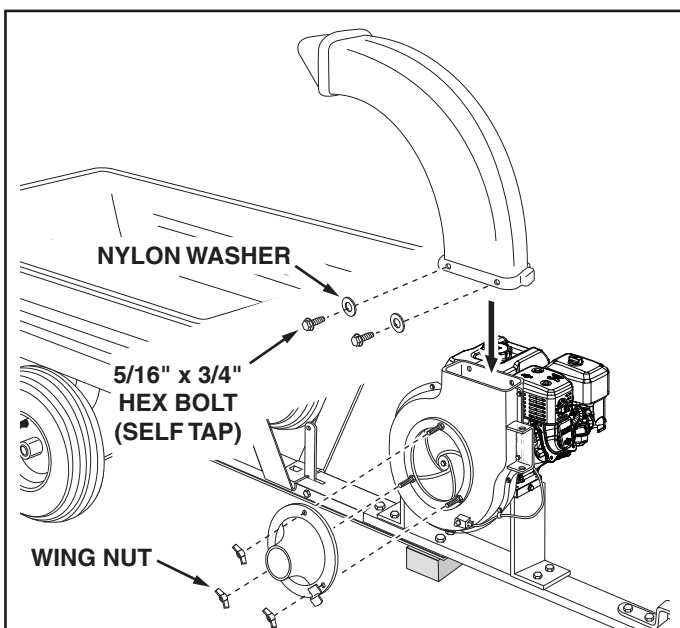

FIGURE 8

- Place the hose hanger rod down into the hose hanger bracket on the impeller housing assembly. See figure 9.

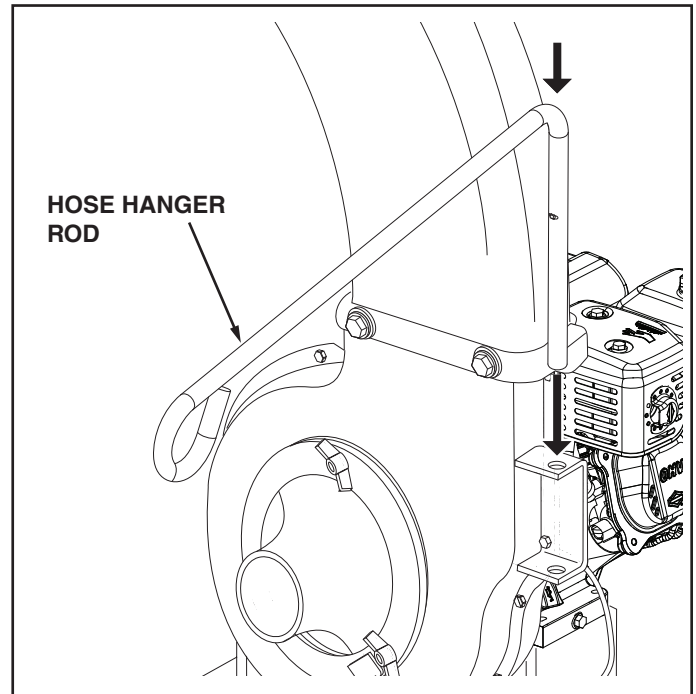

FIGURE 9

- Place a hose clamp onto the end of the hose. Push the hose onto the hose adapter (nozzle). Tighten the hose clamp onto the hose and hose adapter. Do not collapse the hose adapter when tightening the clamp. See figure 10.

- The remaining hose clamp will be used later to fasten the hose to the deck adapter.

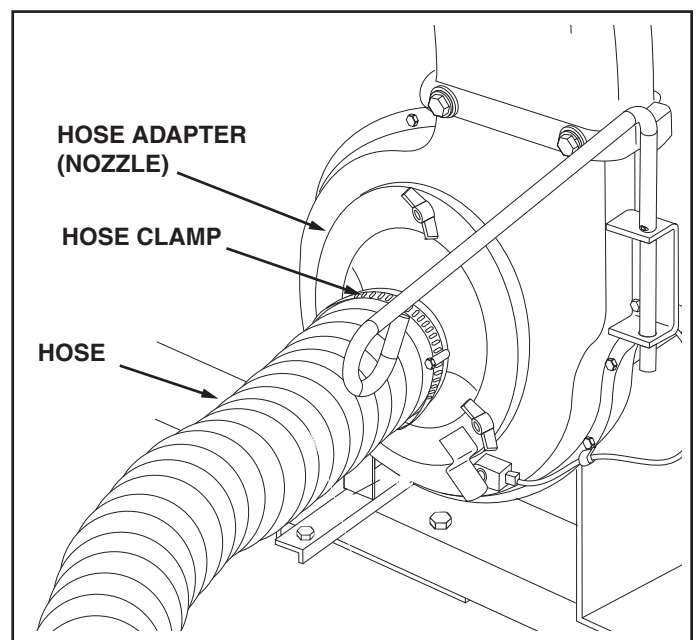

FIGURE 10

- Loop the 25" tarp strap under the hose. Fasten the hooks to the hose hanger rod. See figure 11.

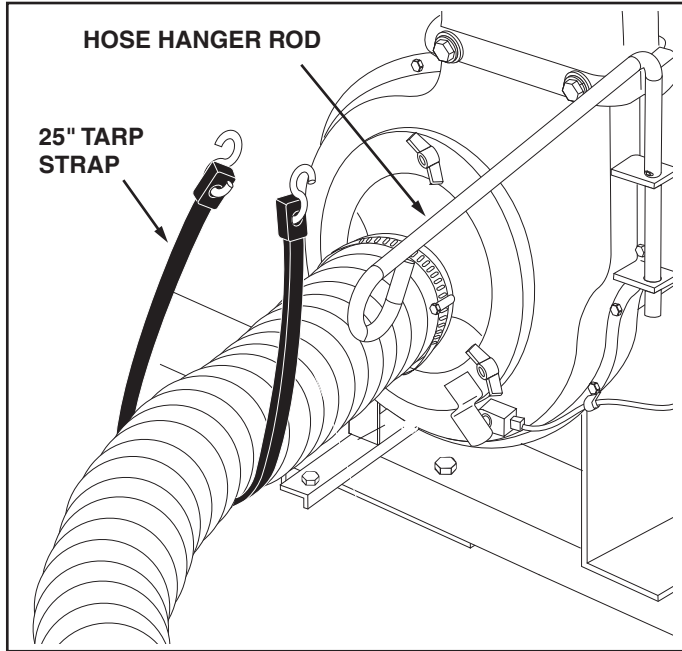

FIGURE 11

- Assemble the hitch plate to the tractor hitch if:
 - Your tractor has a square (straight) hitch frame, to help prevent binding.
 - Your tractor has a lightweight hitch frame that needs reinforcement for towing.
 Use a 1/2" x 1-1/4" hex bolt, a 7/16" flat washer and a 1/2" nylock nut. See figure 12.

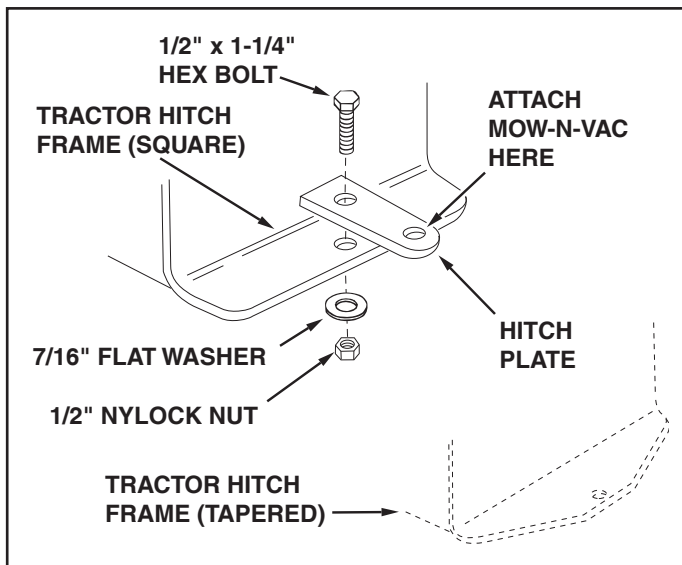

FIGURE 12

CART COVER ASSEMBLY

- Slide the front support tube through the double loops at the front of the cart cover. See figure 13.

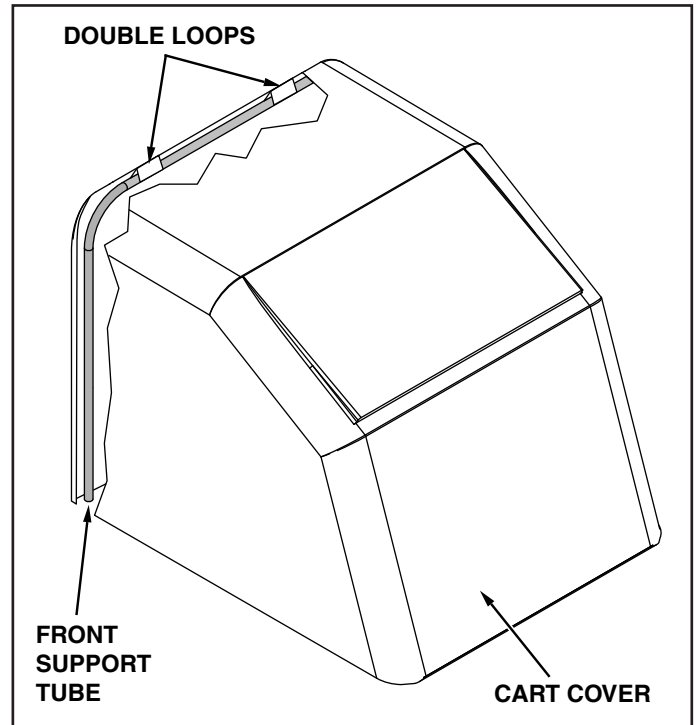

FIGURE 13

- Slide the front support rod (straight ends) through the front sleeve located in the top of the cart cover. Slide a lower support rod (bent ends) through the rear sleeve located behind the front sleeve. The **bend** in the rod must face in the direction shown in figure 14.

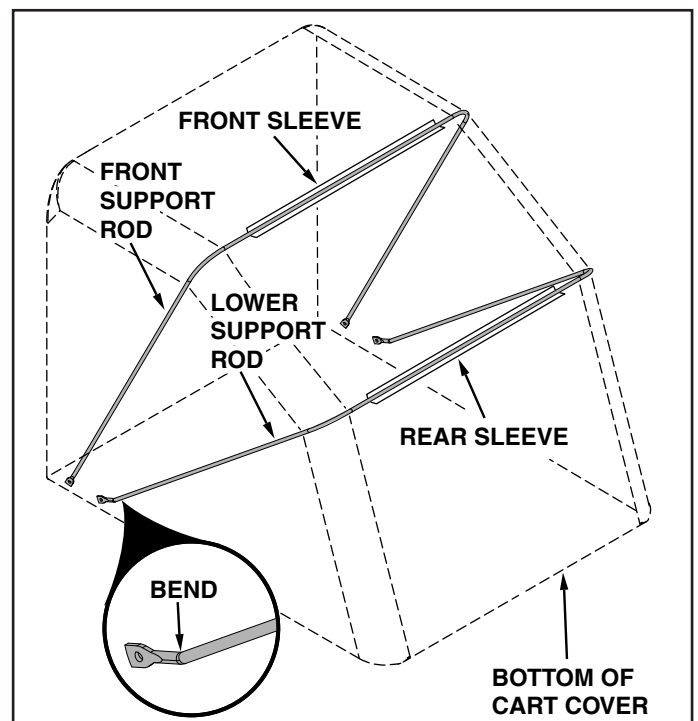

FIGURE 14

- Slide the second lower support rod (bent ends) through the sleeve along the bottom of the cart cover. Slide a looped end of the rope onto the rod as it enters each gap in the sleeve. The **bend** in the rod must face in the direction shown in figure 15.

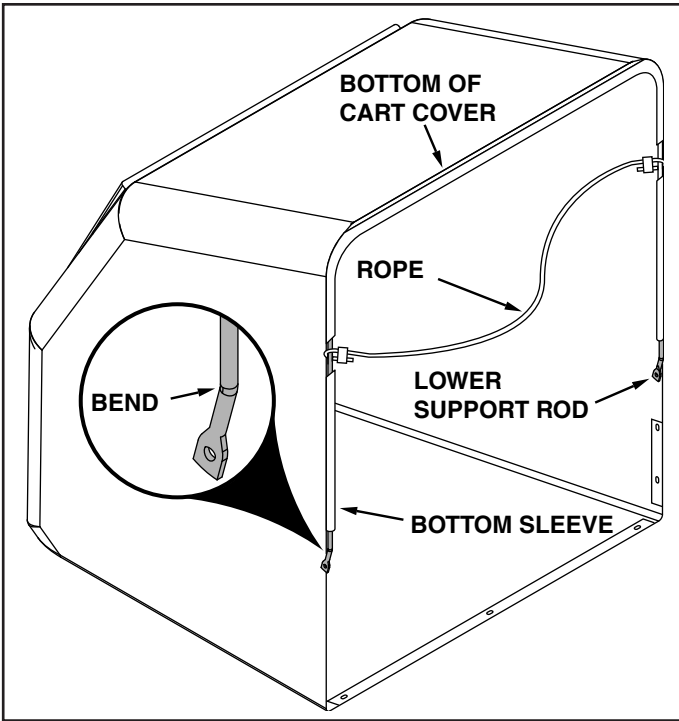

FIGURE 15

- Place the top support angle inside the cart cover. Fold the bottom of the cover around the top support angle. Insert two plastic plugs as shown in figure 17 to secure the cover to the ends of the top support angle.

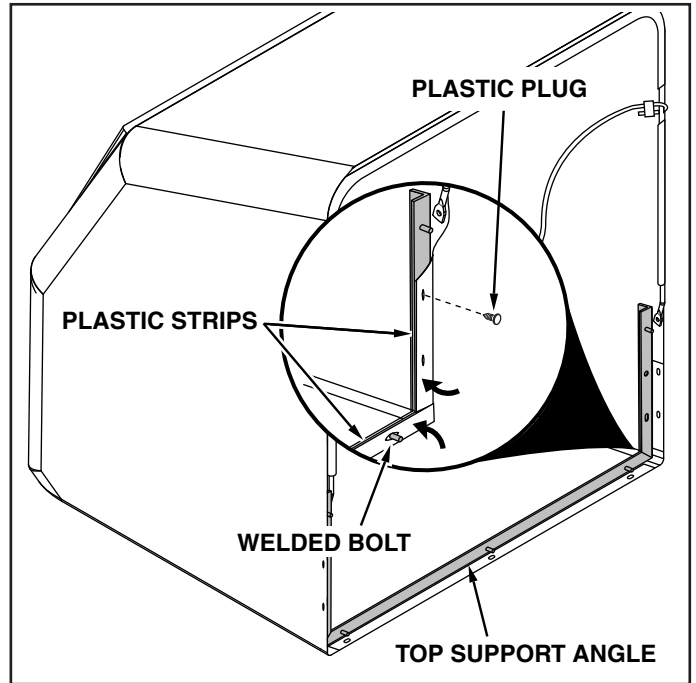

FIGURE 17

- Locate the plastic strips that are stitched to the bottom of the cart cover. Cut seven slits in the cover fabric that align with the holes in the plastic strips. See figure 16.

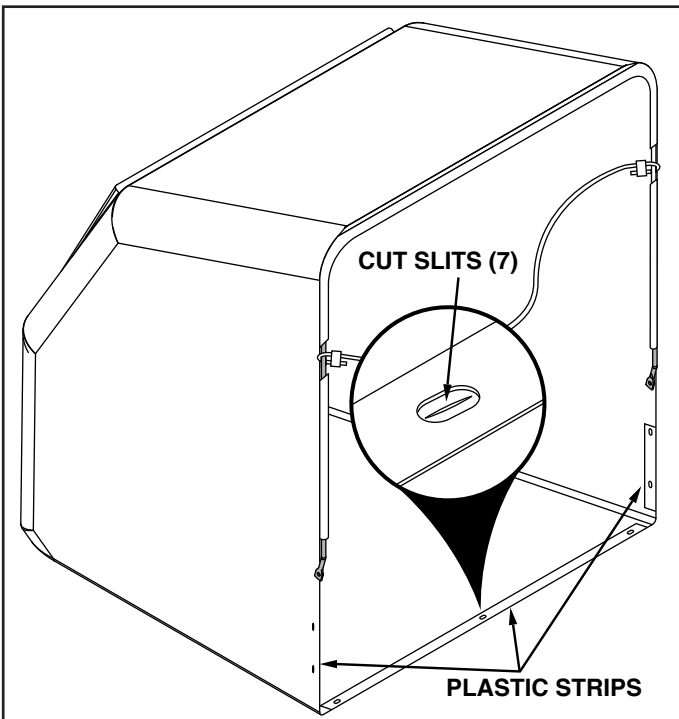

FIGURE 16

- Assemble the five 1/4" x 3/4" carriage bolts and tinnerman nuts as shown, leaving the nuts loose enough that the bolts can slide back and forth in the slots. See figure 18.

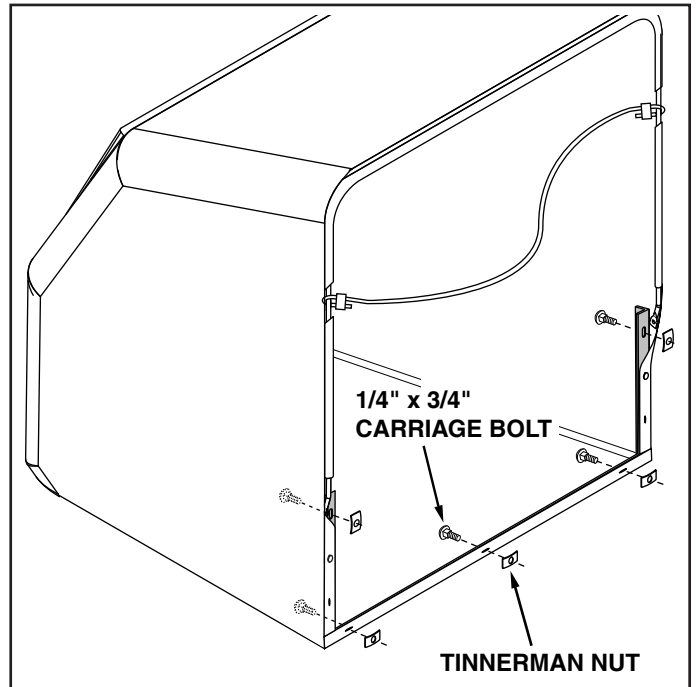

FIGURE 18

- Secure front support tube to top support angle using two 1/4" x 1-1/4" hex bolts and 1/4" lock nuts. **TIGHTEN. Do not over tighten** and collapse support tube. See figure 19.

NOTE: Cart bag not shown for clarity.

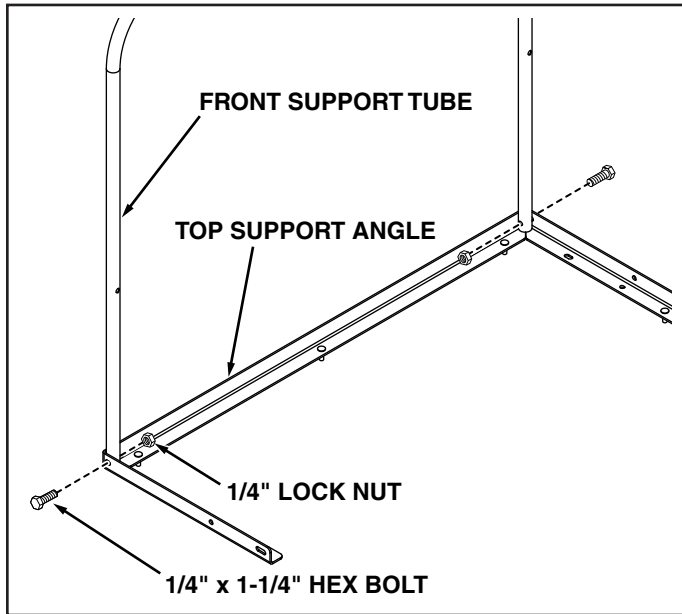

FIGURE 19

- Place the front support rod on the **outside** and the lower support rod on the **inside** of the top angle support. Attach using two 1/4" x 3/4" hex bolts and 1/4" lock nuts. **TIGHTEN** nut only until flush with end of bolt. The rods must pivot freely. See figure 20.

NOTE: Cart bag not shown for clarity.

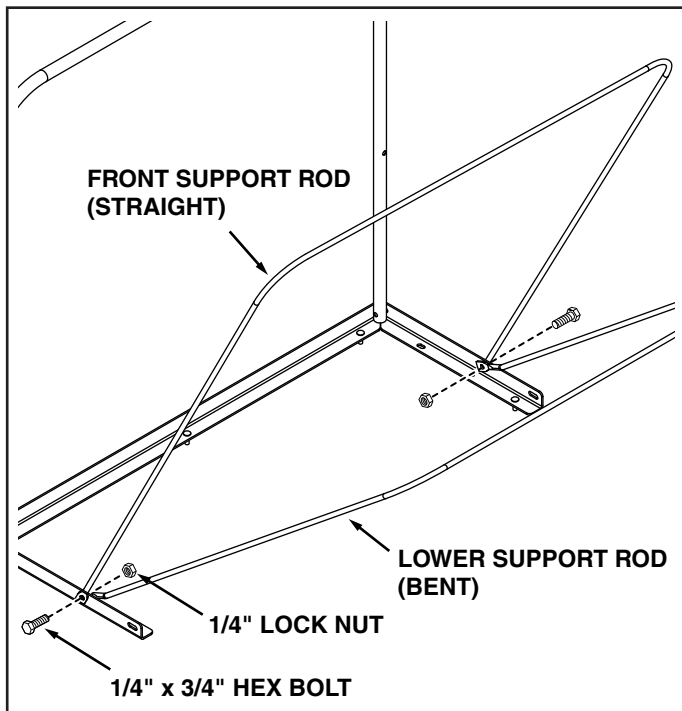

FIGURE 20

- Assemble a 1/4" x 3/4" bolt and 1/4" lock nut to each end of the second lower support rod. **TIGHTEN**, then back nut off 1/2 turn. See figure 21.
- Attach the lower support rod to the **outside** of the top support angle using two 1/4" flanged nuts. **TIGHTEN**. See figure 21.

NOTE: Cart bag not shown for clarity.

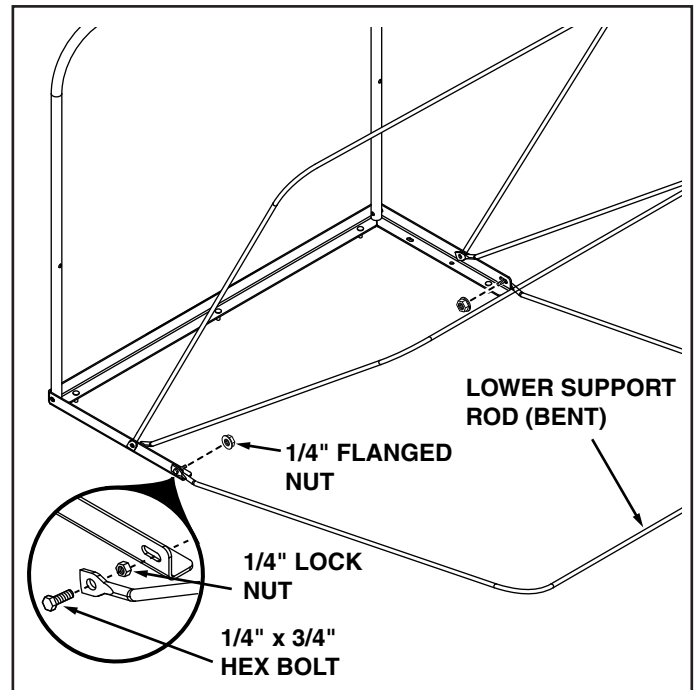

FIGURE 21

- Attach the braces to the front support tube using two 1/4" x 1-1/4" hex bolts and 1/4" flanged nuts. **TIGHTEN. Do not over tighten** and collapse support tube. See figure 22.

NOTE: Cart bag not shown for clarity.

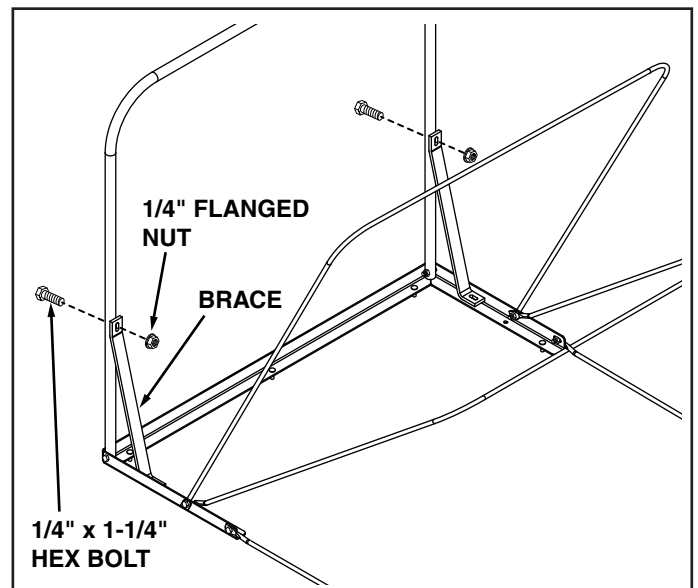

FIGURE 22

- Place the assembled cart cover on top of the cart, aligning the bolts in the top support angle with the holes in the cart. Assemble five 1/4" flanged nuts onto the bolts. **DO NOT TIGHTEN YET**. See figure 23.
- Attach the bottom of the braces to the top support angle and the cart using two 1/4" x 3/4" hex bolts, 1/4" washers and 1/4" flanged nuts. **TIGHTEN**. See figure 23.
- **TIGHTEN** the five 1/4" flanged nuts.

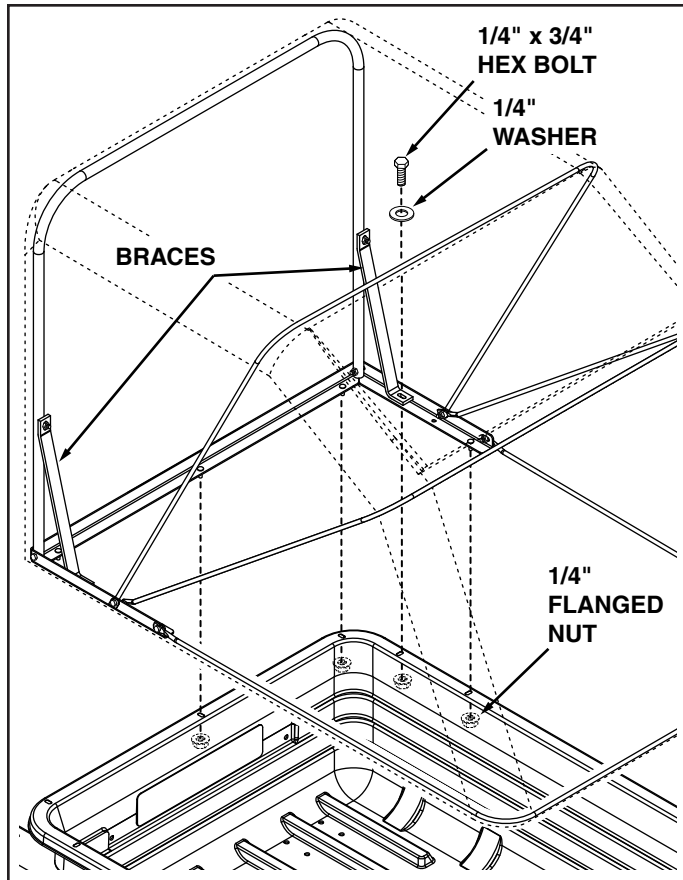

FIGURE 23

- With the rope hanging down loosely, check if the cover fits down freely around the rear of the cart tray. If the cover needs to extend farther to the rear, loosen bolts (a) in figure 24 to slide the support rod rearward.
- If the rear of the cover does not rest down freely around the rear of the cart tray, loosen bolts (b) in figure 24 and tilt the front support tube rearward while sliding the bottom of the braces rearward. Retighten the bolts.

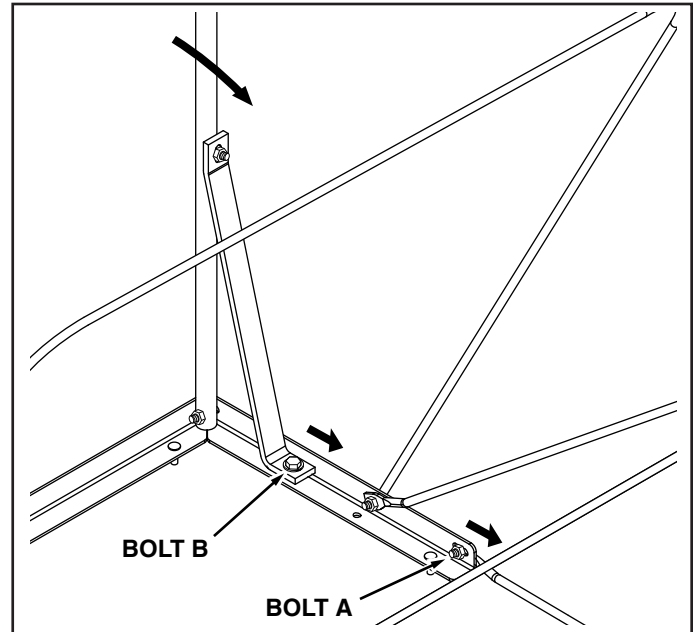

FIGURE 24

- Allow the rope to hang loosely behind the rear of the cart. Use the lanyard to tighten the rope until it firmly secures the cart cover to the cart. See figure 25.
- Ensure lanyard is locked to keep rope in place. See figure 25.

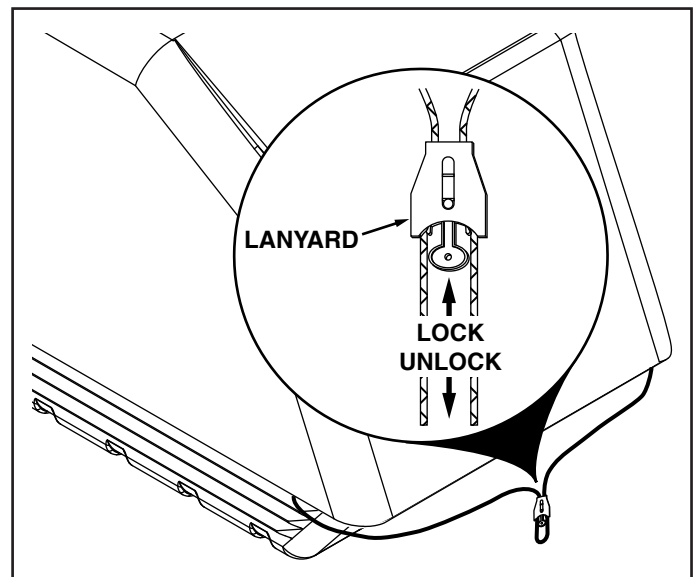

FIGURE 25



BEFORE PROCEEDING, look in the fold-out sheets included with this manual to find templates for Sears mower decks. If written instructions are printed on the template, follow those instructions instead of the instructions in this manual.

ASSEMBLING THE #62468 DECK ADAPTER TO THE MOWER DECK

NOTE: Not all of the parts in the deck adapter hardware package will be needed for your particular fit up.

- Remove the mower discharge deflector from your mower deck. Save the deflector and hardware for remounting deflector.



CAUTION: Mower deflector must be replaced when Vac System deck adapter is removed. Do Not operate mower unless adapter or deflector is in place and properly mounted.

- Identify and cut out the template for your **brand and size** mower deck. If there is no template included for your deck size, you can make your own template by marking around a piece of cardboard held against the edge of the deck's discharge opening.
- Tape the template to the face of the adapter, about 1/2" from front and 1/4" down from top for deeper decks. For shallow decks, position template low enough that adapter will not extend below bottom of deck. Mark outline of template on face of adapter using white crayon, nail or scribe. Drill a starting hole inside the outline, then use a saber saw or key hole saw to cut out the opening. See figure 26.

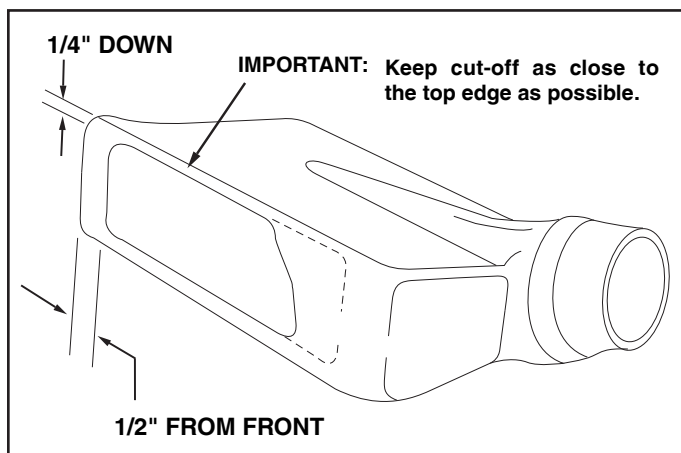

FIGURE 26

- Position the adapter over the deck opening, and check for fit of cutout as shown in figure 27. Trim cutout, if necessary, to allow tilting of adapter, keeping the fit as close as possible for best vacuum suction.

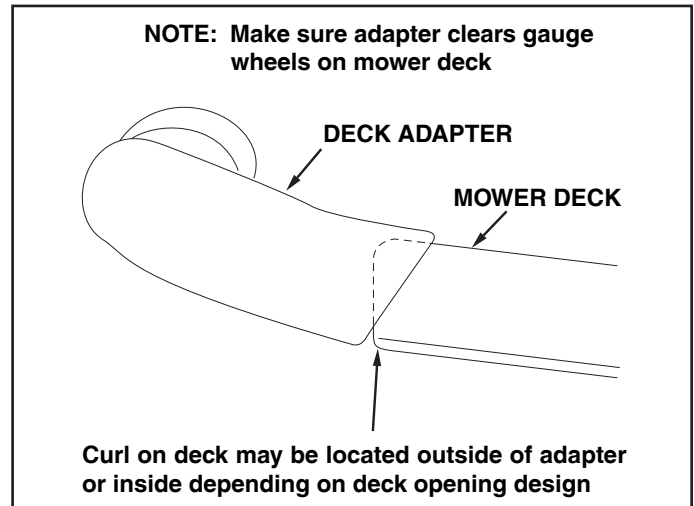

FIGURE 27

- Holding the adapter bracket and the deck adapter together, position the deck adapter on the mower deck. Keeping the edge of deck adapter as close as possible to the offset in the adapter bracket, see if the slot in the adapter bracket can be aligned with one or two of the deflector holes in your mower deck's discharge opening. If the bracket can not be located correctly using existing holes, it will be necessary to drill one or two 5/16" diameter holes in the deck. See figure 28.

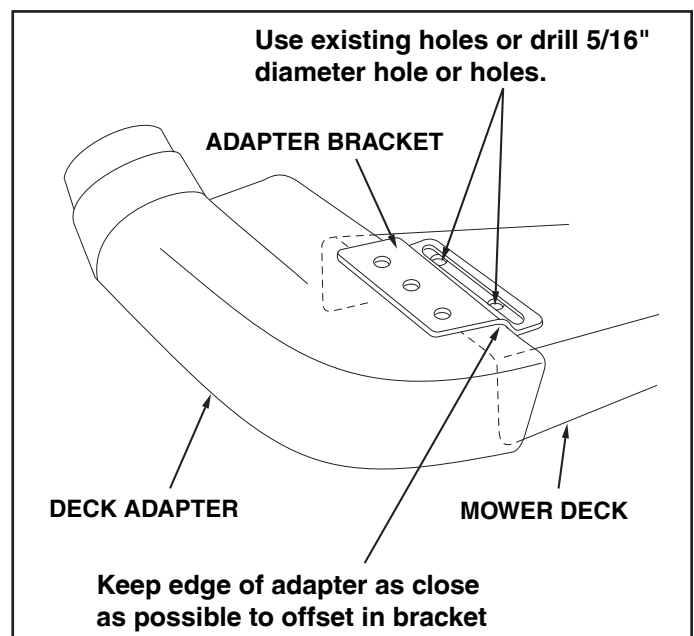

FIGURE 28

- Assemble the adapter bracket to the deck using two 5/16" x 1-1/4" hex bolts, 5/16" flat washers and 5/16" nylock nuts. See figure 29.

NOTE: It may be necessary to use extra 5/16" flat washers to shim under the bracket next to the deck surface. Ten extra washers have been furnished as shims. See figure 29.

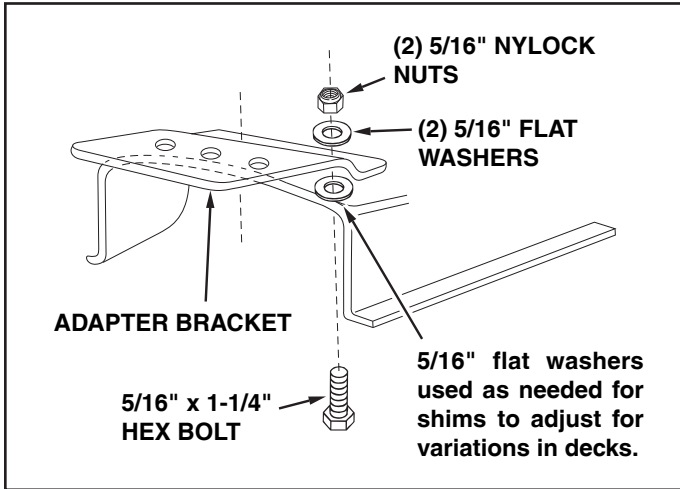

FIGURE 29

- With deck adapter positioned correctly over the discharge opening, use the adapter bracket as a template and drill three 9/32" diameter holes in the top of the deck adapter. See figure 30.
- Bolt deck adapter to bracket using three 1/4" x 1" bolts, nylon washers, 1/4" flat washers and 1/4" nylock nuts. Nylon washers should be against the inside of the deck adapter. See figure 30.

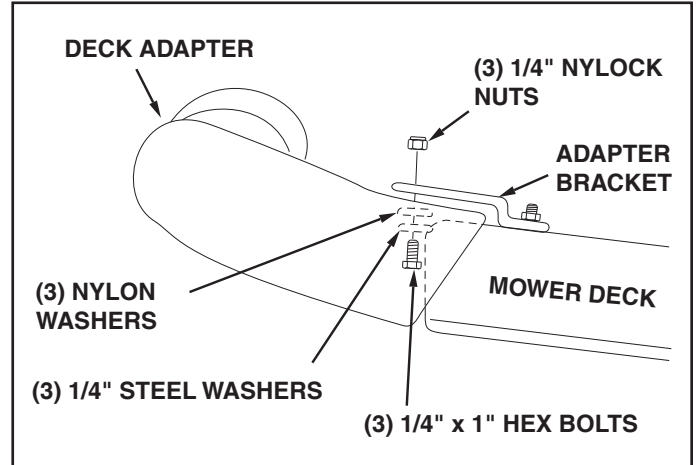

FIGURE 30

- Assemble end of hose and a hose clamp over the round opening of deck adapter and tighten clamp.
- GO DIRECTLY TO THE OPERATION INSTRUCTIONS ON PAGE 18.**

OPERATION

KNOW YOUR VAC SYSTEM

Read this owner's manual and safety rules before operating your Vac System.

Compare the illustration below with your Vac System to familiarize yourself with the various controls and their locations.

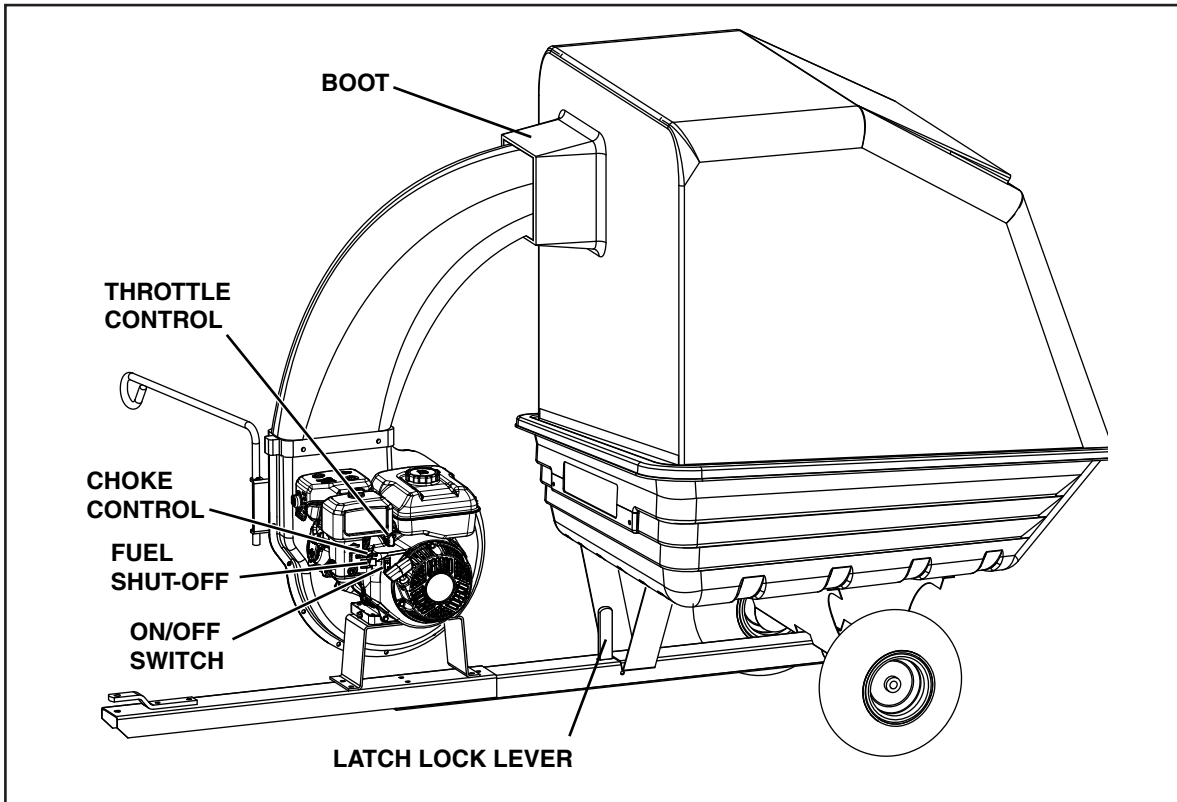

THROTTLE CONTROL Controls speed of engine.

CHOKE CONTROL Adjust to allow cold starting.

FUEL SHUT-OFF Shuts off fuel flow to engine.

ON-OFF SWITCH Turns off engine ignition.

BOOT Connects the plastic elbow to the fabric top, directing discharged material into the cart.

LATCH LOCK LEVER Locks the cart bed down to the tongue. Releases to allow cart to be tipped back for dumping.

CAUTION: Alcohol blended fuels (called gasohol or using ethanol or methanol) can attract moisture which leads to separation and formation of acids during storage. Acidic gas can damage the fuel system of an engine while in storage.

To avoid engine problems, the fuel system should be emptied before storage for 30 days or longer. Drain the gas tank, start the engine and let it run until the fuel lines and carburetor are empty. Use fresh fuel next season.

See STORAGE Instructions for additional information.

Never use engine or carburetor cleaner products in the fuel tank or permanent damage may occur.

BEFORE STARTING

FILL THE ENGINE WITH OIL! Your engine is shipped without oil or gasoline. Add oil as instructed in Engine Maintenance on page 20 of this manual. Add gas as instructed in the separate engine manual.

- Inspect the Vac System to make sure all covers (rear door, vinyl boot, elbow, hose adapter, hose and deck adapter are properly attached.
- Check tires for proper inflation (12 - 14 lbs).

HOW TO STOP YOUR VAC SYSTEM

- To stop engine, move the throttle control lever to the OFF position.
- Disconnect spark plug wire from plug to prevent accidental starting while equipment is unattended or is being worked on.



WARNING: Never fill fuel tank indoors, or with the engine running, or while the engine is hot. Do not smoke while filling tank.



CAUTION: The muffler and adjacent areas are hot!

HOW TO START YOUR VAC SYSTEM



WARNING: Never start or run the engine without all covers being properly attached to the blower housing and cart.

- Check oil and gas in Vac engine.
- Attach spark plug wire to spark plug.
- Move choke lever on engine to CHOKE position. (A warm engine may not require choking.)
- Move throttle control lever on engine to FAST position.
- Grasp starter handle and pull rope out slowly until engine reaches start of compression cycle (rope will pull slightly harder at this point). Let the rope rewind slowly.
- Pull rope with a rapid, continuous, full arm stroke. Keep a firm grip on starter handle. Let rope rewind slowly. Do not let starter handle snap back against starter.
- Repeat instructions in two preceding paragraphs until engine fires. When engine starts, move choke control gradually to RUN position.

HOW TO USE YOUR VAC SYSTEM



CAUTION: Vehicle braking and stability may be affected with the addition of an accessory or an attachment. Be aware of changing conditions on slopes.

- Inspect the Vac to make sure the cover, rear door, boot, elbow, hose adapter (nozzle), hose and deck adapter are properly attached.
- Check tires for proper inflation (12 - 14 lbs).
- Check for oil and gas in Vac engine.
- Begin operation at low speed, adjusting forward speed to match grass height and/or moisture condition to prevent clogging.
- Do not attempt to vacuum up any material other than vegetation found in a normal yard, such as light branches, leaves, twigs, etc.



WARNING: Should your Vac System become clogged, shut off tractor and Vac engines. Before attempting to unclog, remove wire from spark plug to prevent accidental starting.

TO EMPTY THE CART

- Shut off the tractor engine and set the brake.
- Shut off the Vac engine.
- Loosen draw string and pull boot back from the elbow.
- Use rope to secure cover in upright position. Refer to illustration below.
- Release latch lock lever on tongue and tip cart back.
- Using a rake or suitable tool, pull grass clippings and/or leaves out of the cart.

- After the cart is emptied, tip it forward and secure it to the tongue with the latch lock lever. Fold down cover and secure in place with the rope.



CAUTION: To avoid possible injury, be sure that no one is near the cart before releasing the latch lock lever.

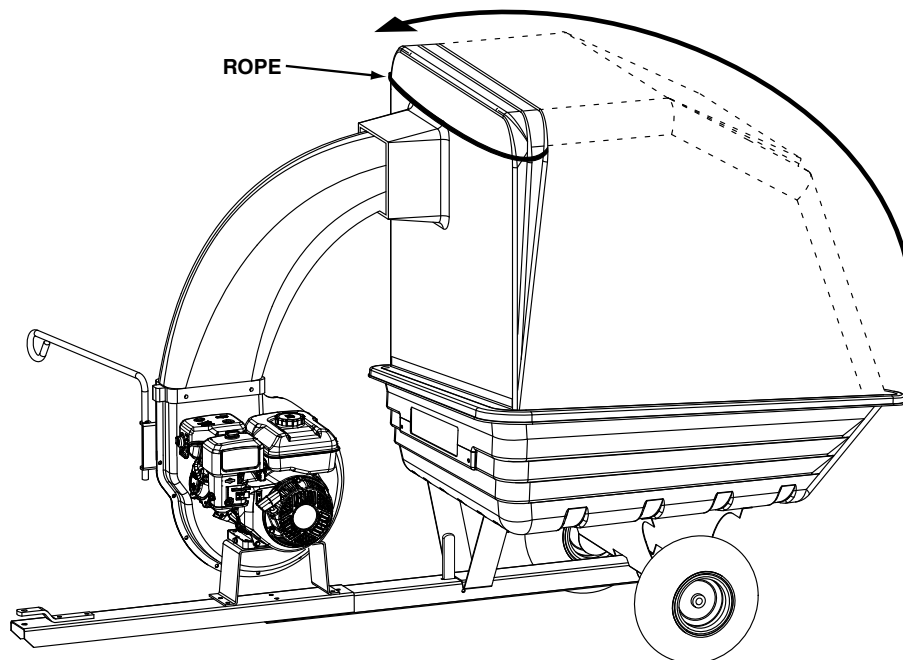

MAINTENANCE

CUSTOMER RESPONSIBILITIES

- Read and follow the maintenance schedule and the maintenance procedures listed in this section.

MAINTENANCE SCHEDULE Fill in dates as you complete regular service.	Service Dates											
	Before each use	After each use	Every season	Before storage								
Check for loose fasteners	X											
Check cover	X											
Check tire pressure	X											
Check engine oil level	X											
Lubricate		X										
Clean		X	X									
Maintain engine per instructions below and in engine manual.												

BEFORE EACH USE

CHECK FOR LOOSE FASTENERS

- Make a thorough visual check of the Vac System for any bolts and nuts which may have loosened. Retighten any loose bolts and nuts.

CHECK COVER

- Check the cover, especially the front boot and the rear flap for wear. Replace cover if worn or damaged.

CHECK TIRE PRESSURE

- Check tire pressure regularly. Recommended tire pressure is 12-14 Lbs.

CHECK ENGINE OIL LEVEL

- Check oil level before each use. Maintain engine oil as instructed in the separate engine manual.

LUBRICATION

- At the beginning of each season, lubricate the latch, latch pivot bolt, and the axle where the hitch tongue pivots, with a light machine oil.
- At least once a season, grease or oil the wheel bearings. Use automotive wheel bearing type grease or 20 weight oil.



WARNING: Always stop engine and disconnect spark plug wire before cleaning, lubricating or before performing any repairs or maintenance.

CLEANING

- Make sure the cart and top are cleaned after each use. Grass clippings and leaves left in the cart will mildew and cause damage if not cleaned out.
- **Clean the engine** regularly with a cloth or brush. Keep the cooling fins on the engine housing clean to permit proper air circulation which is essential to engine performance and life. Be sure to remove all dirt and debris from muffler area.

ENGINE MAINTENANCE

Only use high quality detergent oil rated with API service classification SF or SG. Select the oil's SAE viscosity grade according to your expected operating temperature. SAE 30 grade oil is recommended for warm weather use. For cold weather use refer to the engine manufacturer's Operating and Maintenance Manual.

- Check **oil level** before each use. Maintain engine oil at level shown in figure 31 below.
- Service **air cleaner** every 25 hours under normal conditions. Clean every few hours under extremely dusty conditions. Poor engine performance and flooding usually indicates that the air cleaner should be serviced. To service the air cleaner, refer to the separate engine manual.
- The **spark plug** should be cleaned and the gap reset once a season. Spark plug replacement at the start of each season is recommended. Check the engine manual for correct plug type and gap specifications.

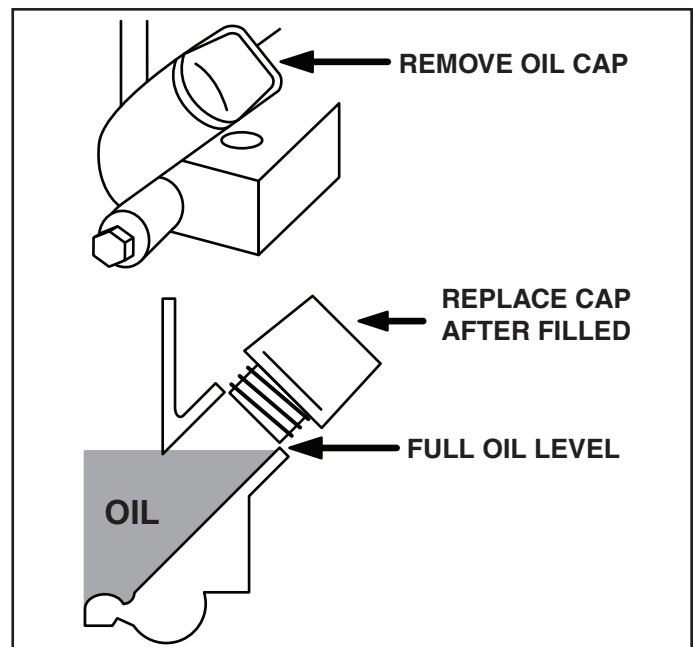

FIGURE 31

STORAGE AND OPTIONAL USE

- Clean the engine and the entire unit thoroughly.
- Refer to engine manual for correct engine storage instructions.
- If storing in an unventilated or metal storage shed, coat metal parts with light oil or silicone to prevent rust.
- Store unit in a clean, dry area.

It is important to prevent gum deposits from forming in essential fuel system parts such as the carburetor, fuel filter, fuel hose or tank during storage. Also, alcohol blended fuels (called gasohol or using ethanol or methanol) can attract moisture which leads to separation and formation of acids during storage. Acidic gas can damage the fuel system of an engine while in storage.

To avoid engine problems, the fuel system should be emptied before storage of 30 days or longer. Follow the instructions in the engine's Operating & Maintenance Manual.

TO USE THE CART WITHOUT THE VAC SYSTEM

- Remove bolts holding frame to cart and store bag and frame in a safe place.



CAUTION: The muffler and adjacent areas are **hot!**

- Keep removed bolts, washers and nuts in a safe place with bag.
- Remove and store the four bolts and nuts which fasten the engine base to the tongue.
- Slide the engine off the tongue and store in a safe storage area.

TROUBLESHOOTING

PROBLEM	POSSIBLE CAUSE(S)	CORRECTIVE ACTION
Engine fails to start	<ol style="list-style-type: none"> 1. Spark plug wire disconnected. 2. Safety switch not contacted. 3. Fuel tank empty, or stale fuel. 4. Fuel shut-off valve closed (if so equipped). 5. Faulty spark plug. 	<ol style="list-style-type: none"> 1. Connect wire to spark plug. 2. Correctly install hose adapter nozzle. 3. Fill tank with clean, fresh fuel. 4. Open fuel shut-off valve. 5. Clean, adjust gap or replace.
Loss of power; operation erratic.	<ol style="list-style-type: none"> 1. Spark plug wire loose 2. Unit running on CHOKE. 3. Blocked fuel line or stale fuel. 4. Water or dirt in fuel system. 5. Carburetor out of adjustment. 6. Dirty air cleaner. 	<ol style="list-style-type: none"> 1. Connect and tighten spark plug wire. 2. Move choke lever to OFF position. 3. Clean fuel line; fill tank with clean fresh gasoline. 4. Disconnect fuel line at carburetor to drain fuel tank. Refill with fresh fuel. 5. Adjust carburetor.* 6. Service air cleaner.*
Engine overheats	<ol style="list-style-type: none"> 1. Carburetor not adjusted properly. 2. Engine oil level low. 	<ol style="list-style-type: none"> 1. Adjust carburetor.* 2. Fill crankcase with proper oil.
Too much vibration	<ol style="list-style-type: none"> 1. Loose parts or damaged impeller. 	<ol style="list-style-type: none"> 1. Stop engine immediately and disconnect spark plug wire. Tighten all bolts and nuts. Make all necessary repairs. If vibration continues, have unit serviced by an authorized service dealer.
Unit does not discharge	<ol style="list-style-type: none"> 1. Discharge chute (elbow) clogged. 2. Foreign object lodged in impeller. 3. Vac Cart is full. 	<ol style="list-style-type: none"> 1. Stop engine immediately and disconnect spark plug wire. Clean inside of housing and discharge chute (elbow). 2. Stop engine immediately and disconnect spark plug wire. Remove lodged object. 3. Empty cart.

*Refer to the engine manual packed with your unit.

NOTE: For repairs beyond the minor adjustments listed above, please contact your nearest authorized service dealer.

REPAIR PARTS LIST FOR 486.25012 VAC

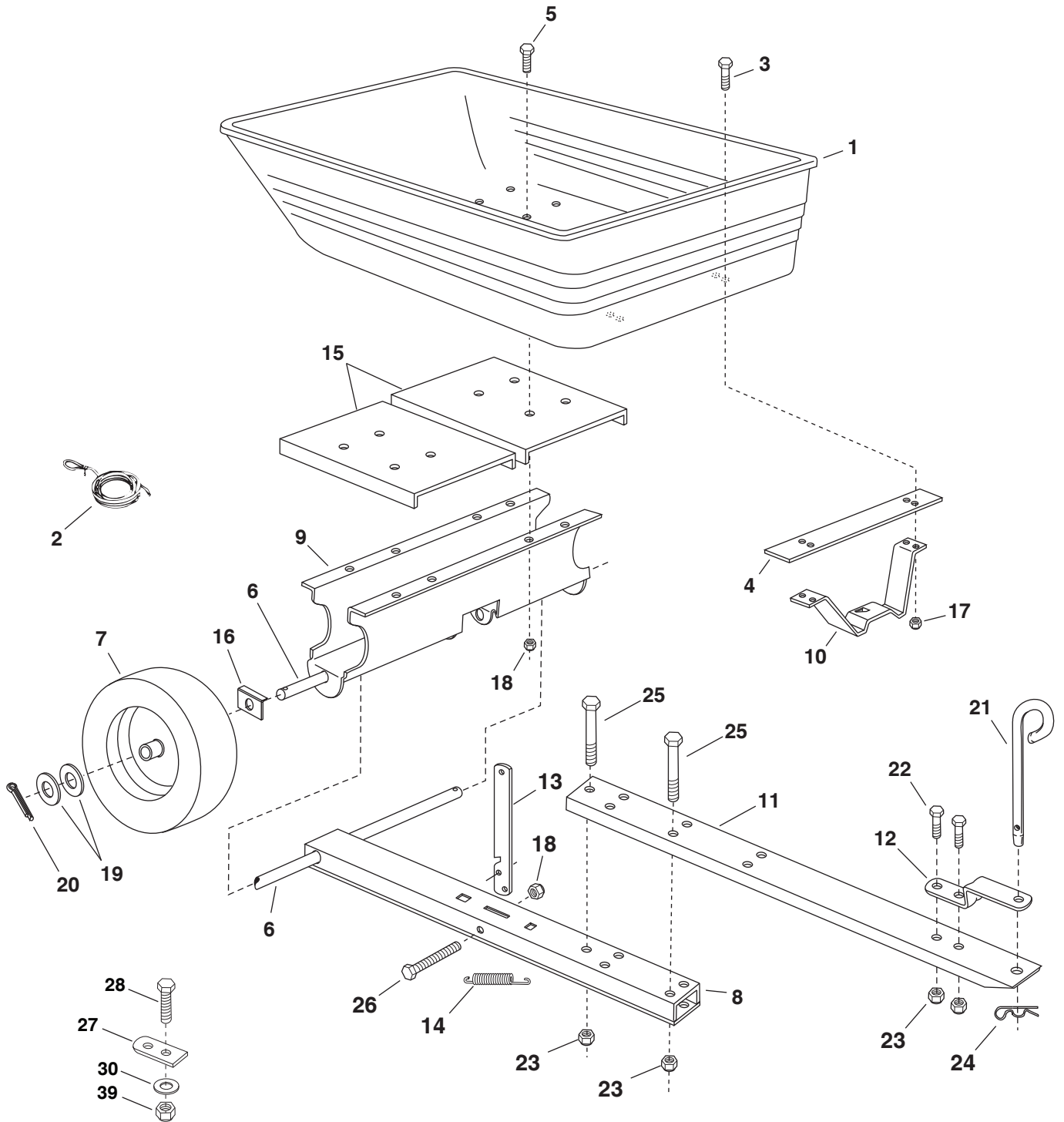

REPAIR PARTS LIST FOR 486.25012 VAC

REF. NO.	PART NO.	QTY.	DESCRIPTION	REF. NO.	PART NO.	QTY.	DESCRIPTION
1	48791	1	Cart Tray	17	47189	4	Nylock Nut, 1/4-20
2	65518	1	Rope, 36"	18	47810	9	Nylock Nut, 5/16-18
3	43012	4	Hex Bolt, 1/4-20 x 3/4"	19	R19212016	4	Washer, 5/8"
4	24386	1	Latch Stand Plate	20	43010	2	Cotter Pin
5	43182	8	Hex Bolt, 5/16-18 x 3/4"	21	23353	1	Hitch Pin
6	26008	1	Axle	22	43001	2	Hex Bolt, 3/8-16 x 1"
7	40880	2	Wheel	23	HA21362	5	Nylock Nut, 3/8-16
8	65442	1	Rear Tongue	24	43343	1	Hair Cotter Pin, 3/32"
9	24527	1	Wheel Support	25	43574	3	Hex Bolt, 3/8-16 x 3"
10	24497	1	Latch Stand Bracket	26	47407	1	Hex Bolt, 5/16-18 x 4"
11	25742	1	Front Tongue	27	23540	1	Hitch Plate
12	23475	1	Hitch Bracket	28	43351	1	Hex Bolt, 1/2-13 x 1-1/4"
13	25010	1	Latch Lock Lever	29	712-3083	1	Nylock Nut, 1/2-13
14	HA20186	1	Spring	30	43352	1	Flat Washer, 7/16"
15	25875	2	Cart Bed Brace				
16	25910	2	Axle Clip				

REPAIR PARTS FOR MODEL 486.25012 VAC

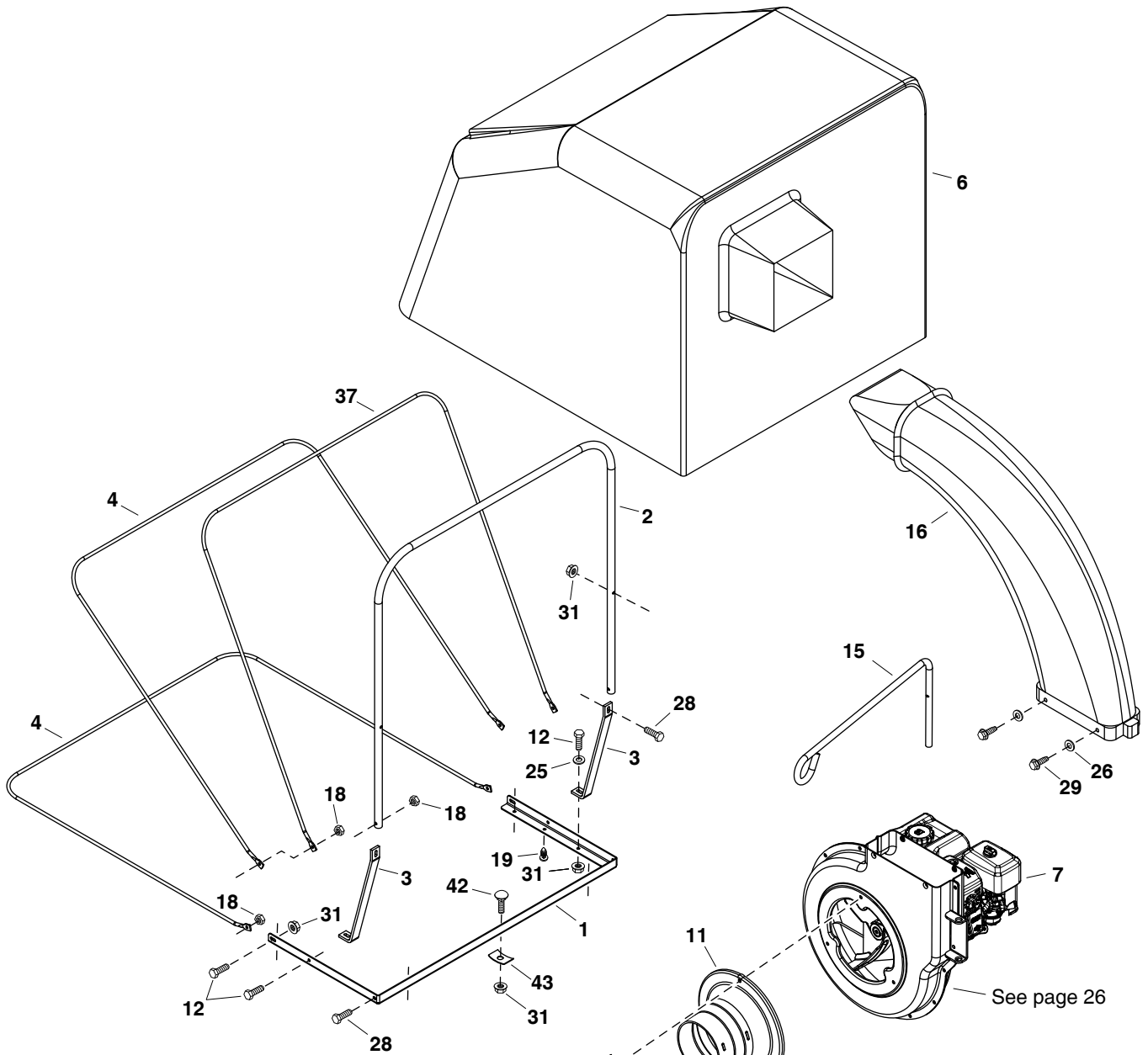

ADAPTER #62468

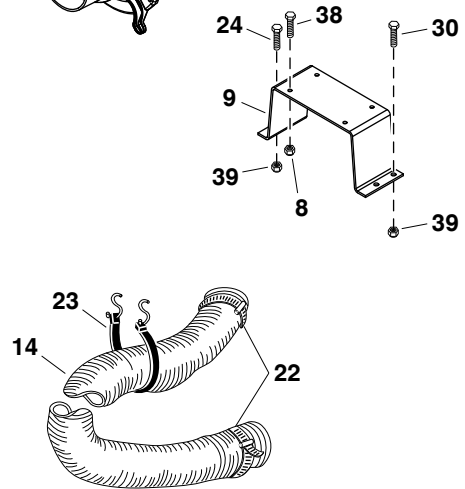
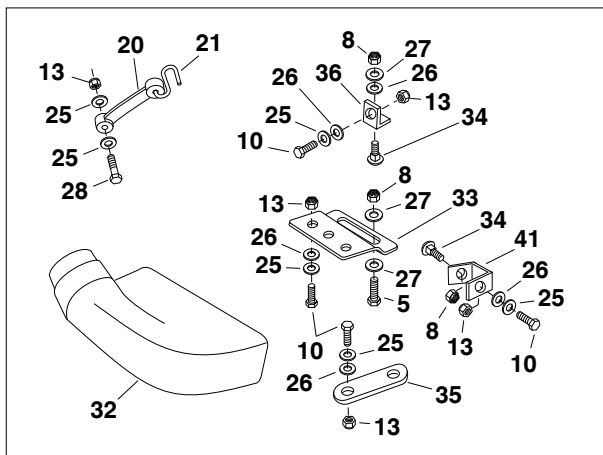

REPAIR PARTS FOR MODEL 486.25012 VAC

REF. NO.	PART NO.	QTY.	DESCRIPTION	REF. NO.	PART NO.	QTY.	DESCRIPTION
1	27144	1	Top Support Angle	24	43574	2	Hex Bolt, 3/8-16 x 3"
2	25874	1	Front Support Tube	25	43088	11	Washer, 1/4" Std.
3	25876	2	Brace	26	1543-69	9	Nylon Washer
4	49873	2	Lower Support Rod	27	43081	12	Washer, 5/16" Std.
5	43840	2	Hex Bolt, 5/16-18 x 1-1/4"	28	1509-90	7	Hex Bolt, 1/4-20 x 1-1/4"
6	42479	1	Cart Cover	29	47630	4	Hex Bolt, 5/16-18 x 3/4"
7	42460	1	Engine				(Thread Forming)
8	47810	7	Nylock Nut, 5/16-18	30	43001	2	Hex Bolt, 3/8-16 x 1"
9	25873	1	Engine Mounting Base	31	47598	11	Nut, Hex Flange 1/4-20
10	43661	4	Hex Bolt, 1/4-20 x 1"	32	43830	1	Deck Adapter
11	43791	1	Hose Adapter	33	23560	1	Deck Adapter Bracket
12	43012	6	Hex Bolt, 1/4-20 x 3/4"	34	43080	2	Carriage Bolt, 5/16" x 3/4"
13	47189	5	Nylock Nut, 1/4-20	35	23825	1	Mounting Strap
14	41882	1	Hose	36	23826	1	Angle Bracket
15	49974	1	Hose Hanger Rod	37	49872	1	Front Support Rod
16	46420	1	Elbow with Deflector	38	43085	4	Hex Bolt, 5/16-18 x 1-1/2"
17	712-0421	3	Wing Nut	39	HA21362	4	Nylock Nut, 3/8-16
18	43013	6	Lock Nut, 1/4-20	40	62468	1	Deck Adapter Kit
19	48402	2	Plug, Plastic	41	23827	1	Mounting Bracket
20	44850	2	Tarp Strap	42	44950	5	Carriage Bolt, 1/4-20 x 3/4"
21	44849	2	"S" Hook	43	41518	5	Tinnerman Nut, 1/4-20
22	43793	2	Hose Clamp		42482	1	Owners Manual
23	43790	1	Tarp Strap, 25"				

REPAIR PARTS LIST FOR 486.25012 VAC

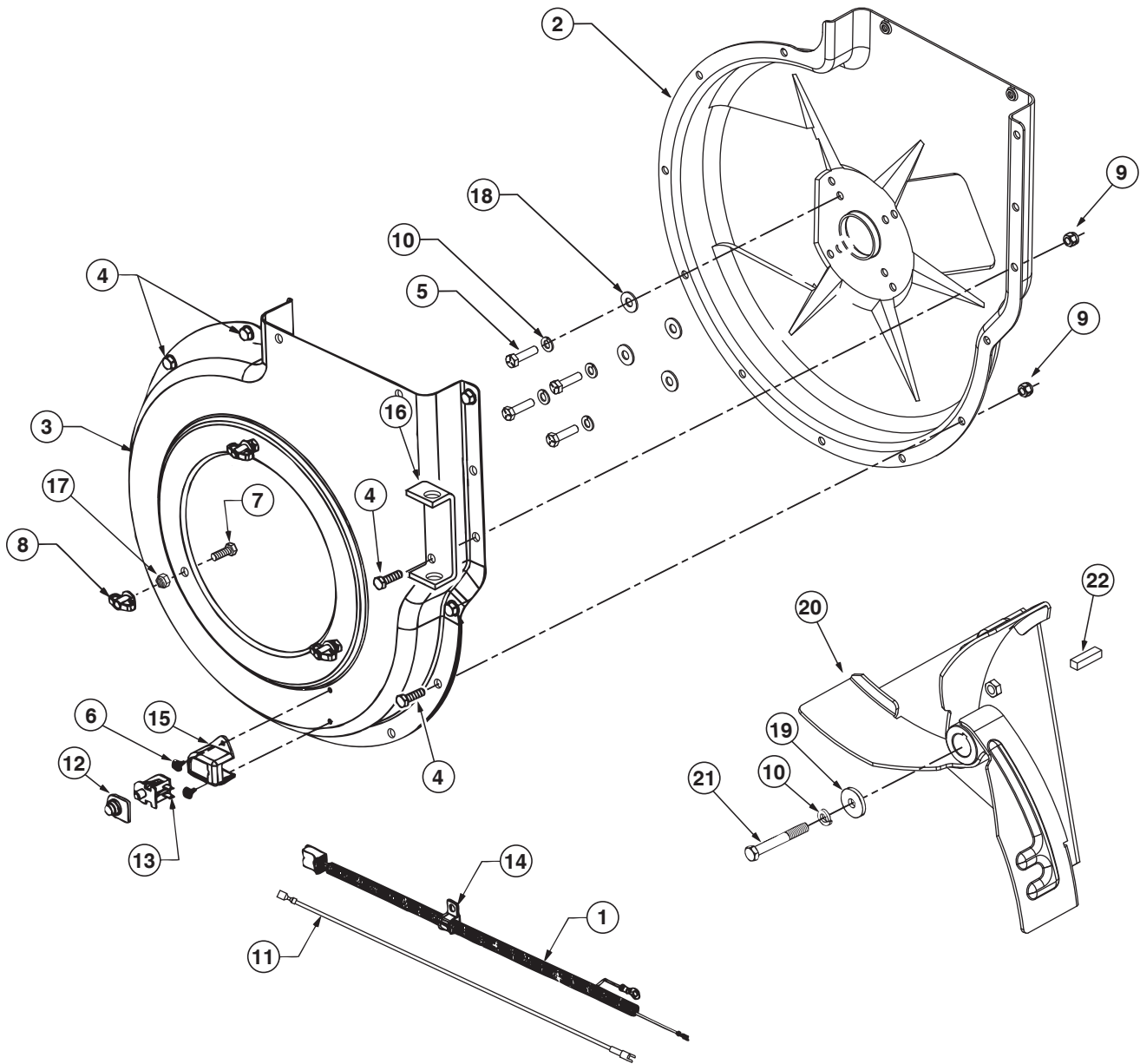

REF. NO.	PART NO.	QTY.	DESCRIPTION	REF. NO.	PART NO.	QTY.	DESCRIPTION
1	629-0241A	1	Harness, Wire	12	725-1700	1	Switch Cover
2	24634	1	Housing Assembly, Inner	13	725-3166	1	Snap Mount Switch
3	24633	1	Housing Assembly, Outer	14	726-0272	1	Clamp
4	43182	12	Hex Bolt, 5/16-18 x 3/4"	15	731-1613	1	Switch Cover
5	47600	4	Hex Bolt, 5/16-24 x 1"	16	24958	1	Hose Hanger Bracket
6	710-1268	2	Screw, Self Tap #10-16 x 3/8"	17	46584	3	Hex Nut, Whizlock 5/16-18
7	43063	3	Hex Bolt, 5/16-18 x 1"	18	43081	4	Washer, 5/16" Std.
8	712-0421	3	Wing nut	19	736-0247	1	Washer
9	47810	12	Nylock Nut, 5/16-18	20	66995	1	Impeller Assembly
10	43086	5	Lock Washer, 5/16"	21	40320	1	Hex Bolt, 5/16-24 x 1-1/4" Locking
11	41480	1	Wire Mag. Ground	22	HA11154	1	Key, 3/16" Sq. x 1.75"

SUGGESTED GUIDE FOR SIGHTING SLOPES FOR SAFE OPERATION OF TRACTOR WITH ATTACHMENT

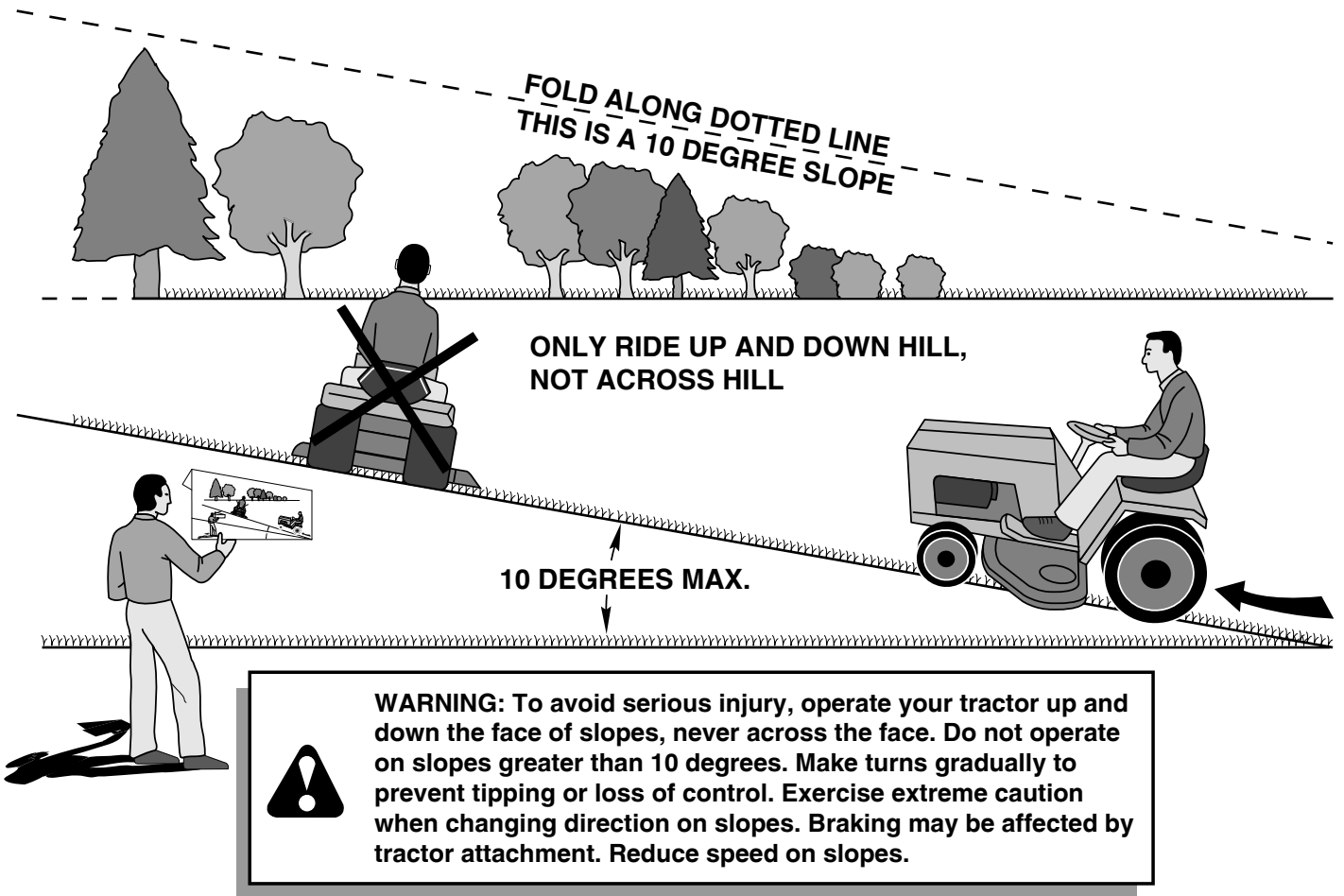

1. Fold this page along dotted line indicated above.
2. Hold page before you so that its left edge is vertically parallel to a tree trunk or other upright structure.
3. Sight across the fold in the direction of hill slope you want to measure.
4. Compare the angle of the fold with the slope of the hill.

CRAFTSMAN®

**Riding Equipment
questions or problems?**

**Satisfaction with your purchase
is our number one concern!**

**To troubleshoot problems,
get answers to questions, order parts,
or schedule repair service for your
Riding Equipment, call the number below.**

**Para respuestas a preguntas o problemas,
y ordenar piezas o pedir servicio para la
reparación de su equipo, llame el número abajo.**

1-800-659-5917

Craftsman Help Line

www.craftsman.com