

Thank you for purchasing the **Cole Six Drawer Dresser**. This page lists all the contents included in the boxes. Please take time to identify the hardware as well as the individual components of this product. As you unpack and prepare for assembly, place the contents on a carpeted or padded area to protect them from damage. Note: 2 people are required to safely assemble this product.

HARDWARE

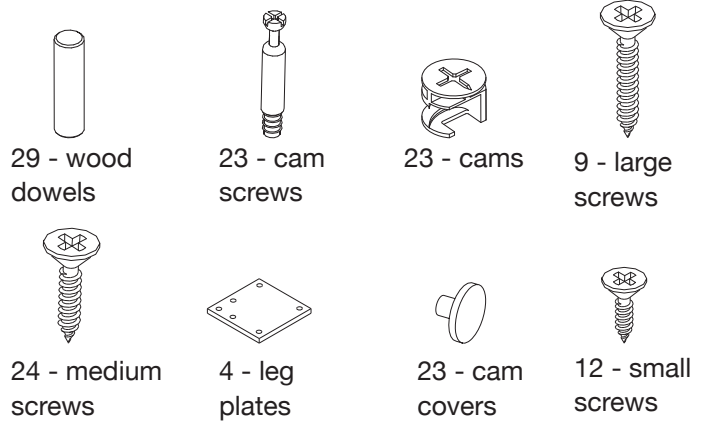

Missing hardware? Please call **800.606.6387** for replacements.

TOOLS REQUIRED

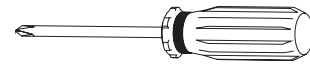

Phillips head screwdriver

COMPONENTS BOX 1

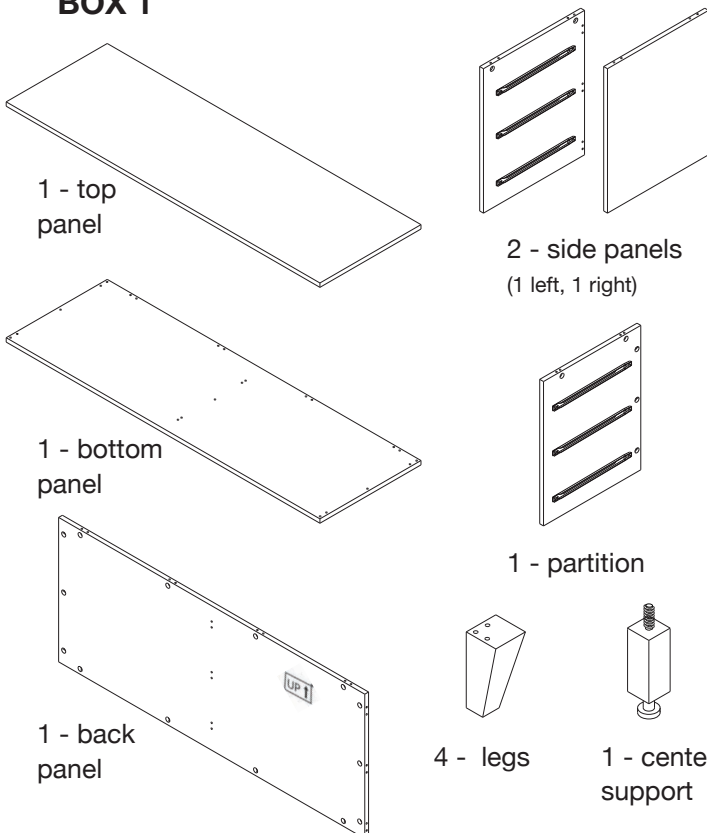

COMPONENTS BOX 2

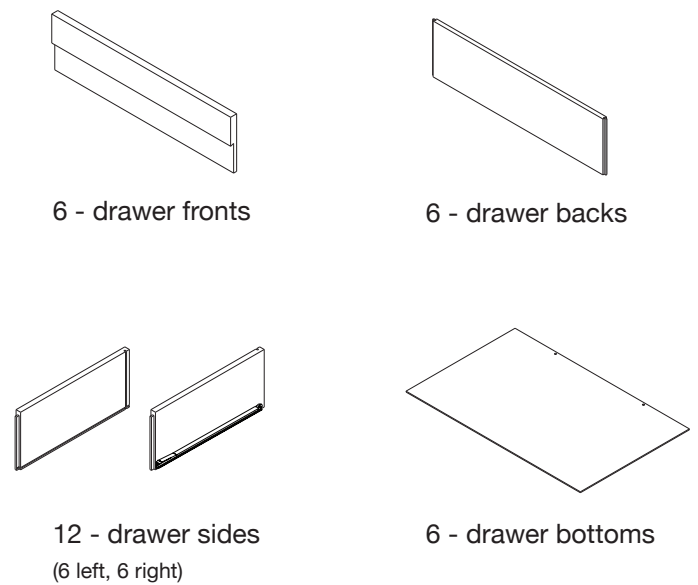

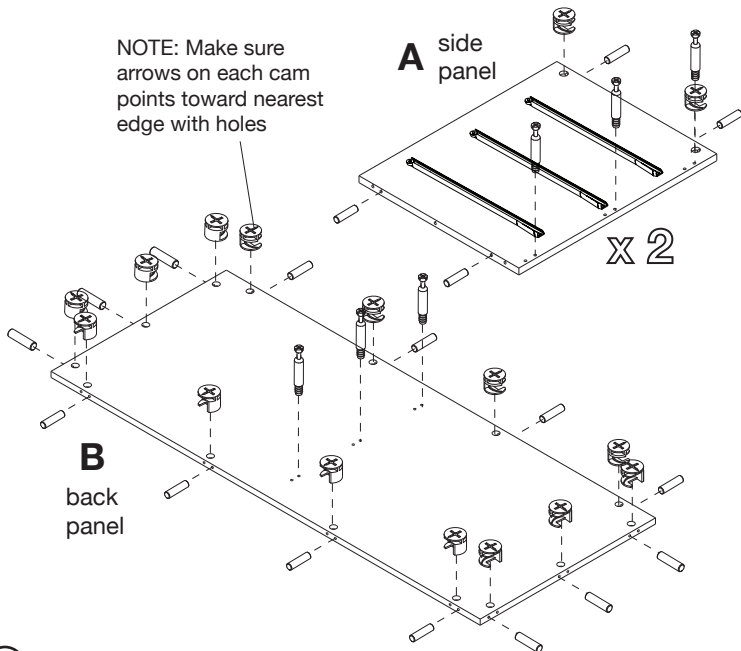

- ① A) Insert 4 **wood dowels**, 3 **cam screws**, and 2 **cams** into **left and right side panels** as shown. Secure cam screws with a **Phillips head screwdriver**. Make sure arrows on each cam points toward nearest edge with holes.
 B) Insert 14 **cams**, 3 **cam screws** and 14 **wood dowels** into **back panel** as shown.

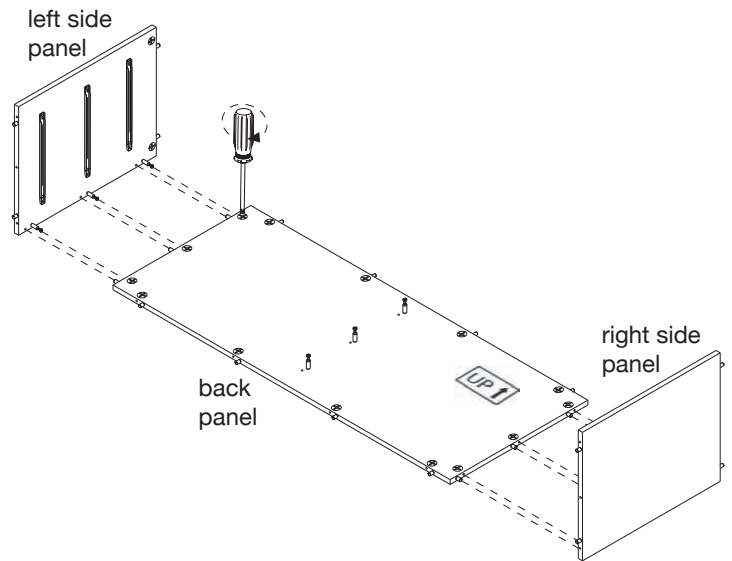

- ② Fit dowels of **back panel** into corresponding holes of **left and right side panels** as shown. With a screwdriver, turn **cams** clockwise until it securely engages each cam screw.

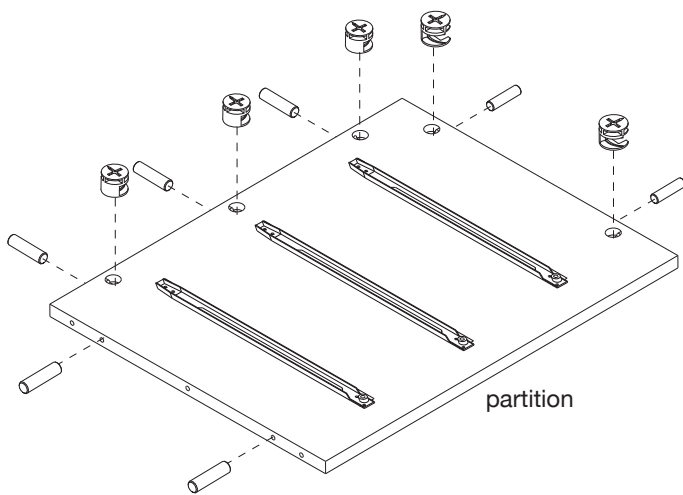

- ③ Insert 5 **cams** and 7 **wood dowels** into **partition** as shown.

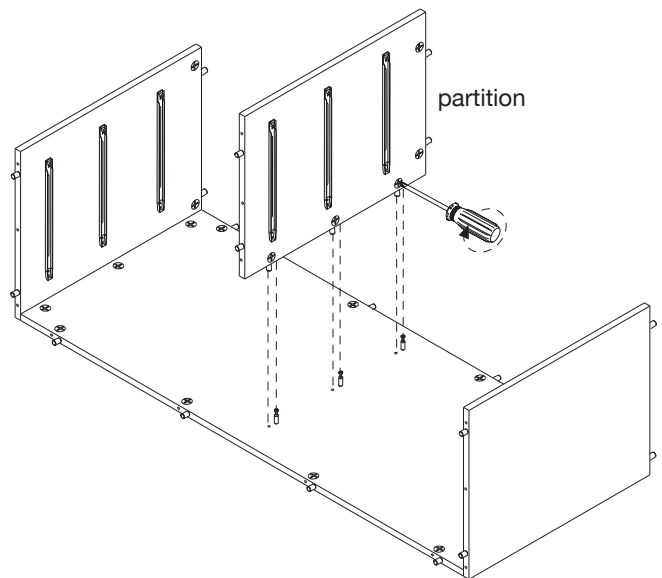

- ④ Fit dowels of **partition** into corresponding holes of assembled unit as shown. Secure 3 **cams**.

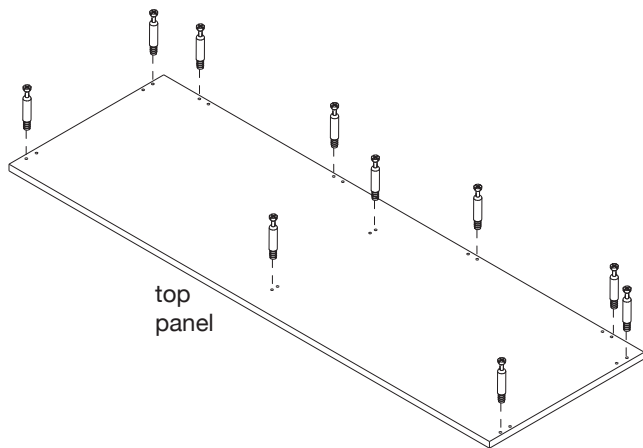

⑤ Insert 10 **cam screws** into **top panel** as shown.

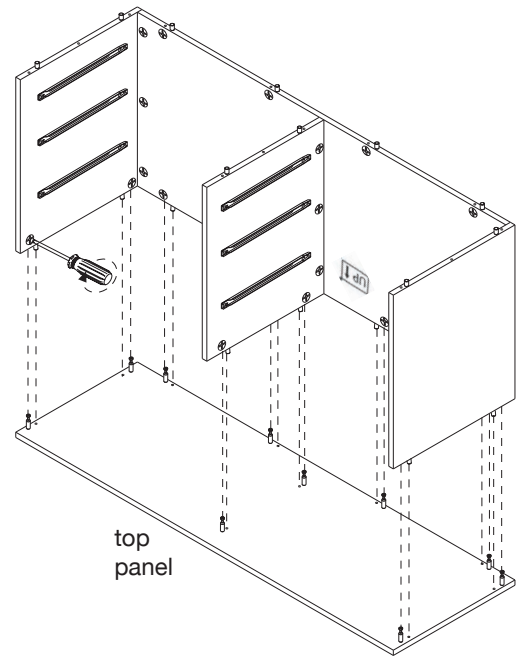

⑥ With the assistance of another adult, position assembly as shown. Fit dowels of assembled unit into corresponding holes of **top panel** as shown. Secure 10 **cams**.

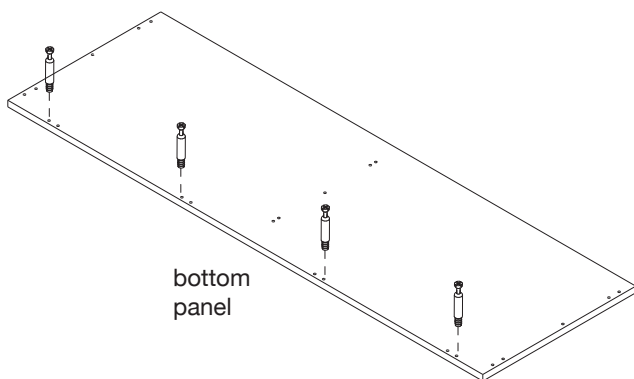

⑦ Insert 4 **cam screws** into **bottom panel** as shown.

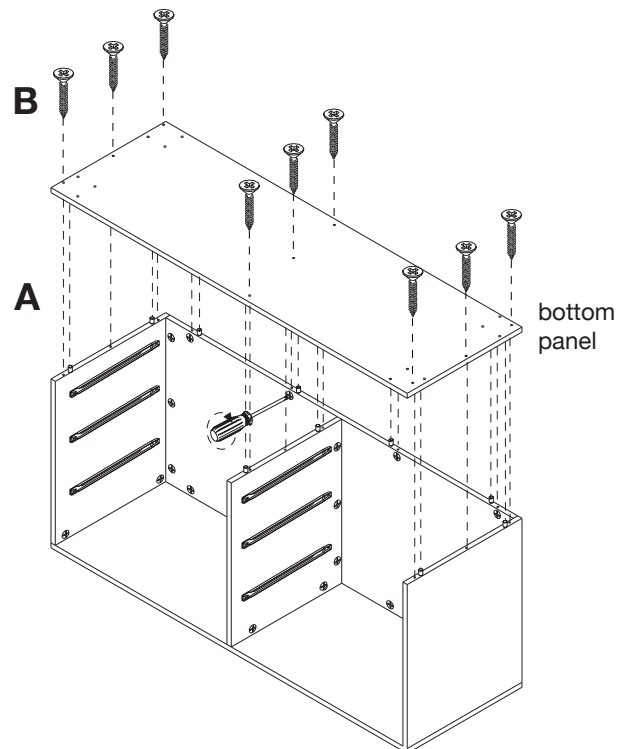

⑧ A) Fit dowels of assembled unit into corresponding holes of **bottom panel** as shown. Secure 4 **cams**.
B) Secure bottom panel with 9 **large screws** as shown, using a **phillips head screwdriver**.

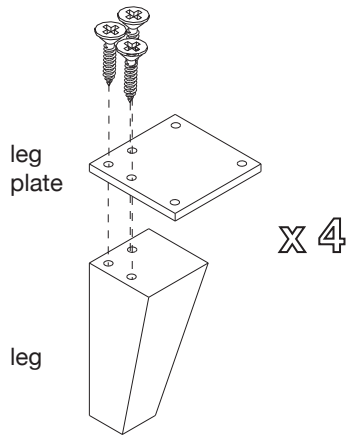

⑨ Attach **leg plate** to **leg** with 3 **medium screws** per leg as shown. Secure screws with a screwdriver.

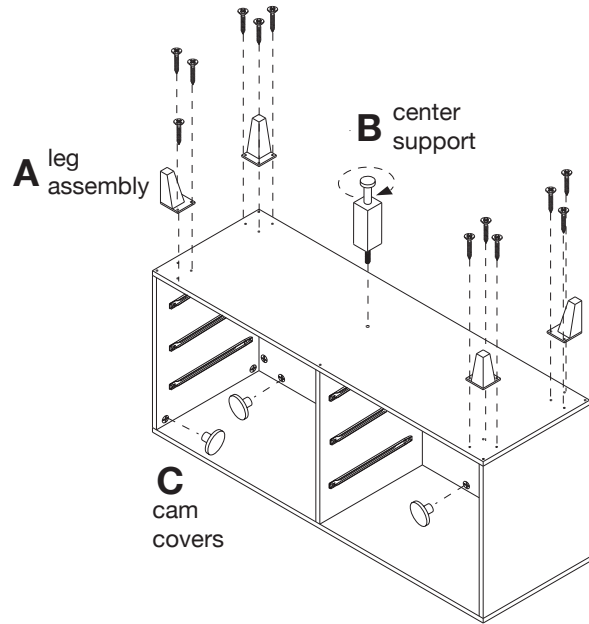

⑩ A) Attach 4 leg assemblies onto bottom of assembled unit with 3 **medium screws** per leg assembly as shown. Secure, but do not overtighten screws with a screwdriver.
 B) Attach **center support** onto bottom of assembled unit. Turn **center support** clockwise to secure as shown.
 C) Conceal all exposed cams with **cam covers**.

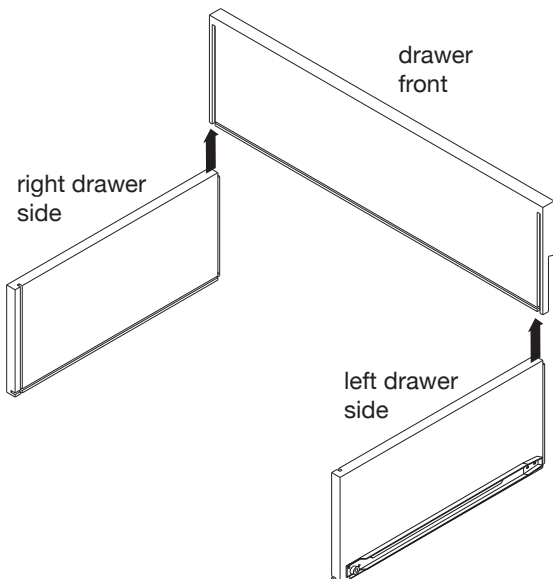

⑪ Slide **left and right drawer sides** into corresponding grooves of **drawer front** as shown.

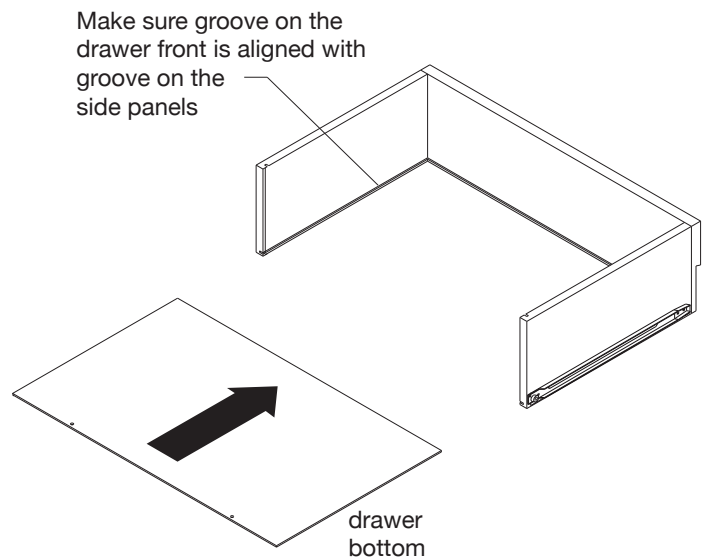

⑫ Slide **drawer bottom** into corresponding grooves of drawer assembly as shown.

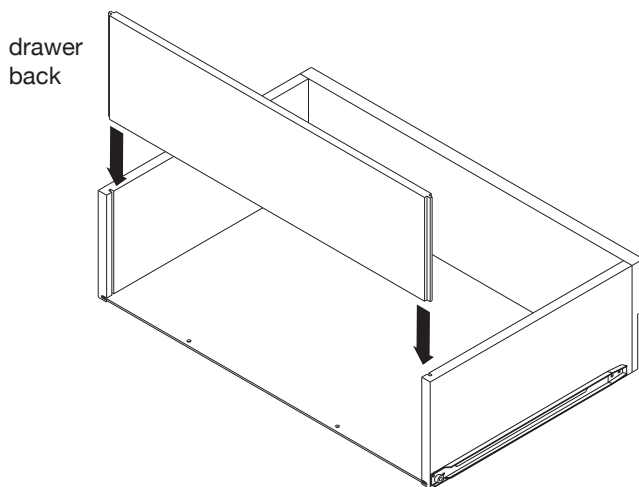

⑬ Slide **drawer back** into corresponding grooves of drawer assembly as shown.

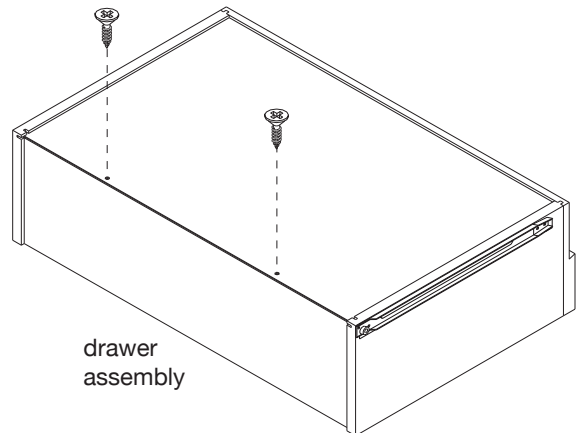

⑭ Place drawer assembly upside down onto a clean, padded surface as shown. Secure drawer bottom of drawer assembly with 2 **small screws** as shown, using a screwdriver.
Repeat steps 11-14 for remaining 5 drawer assemblies.

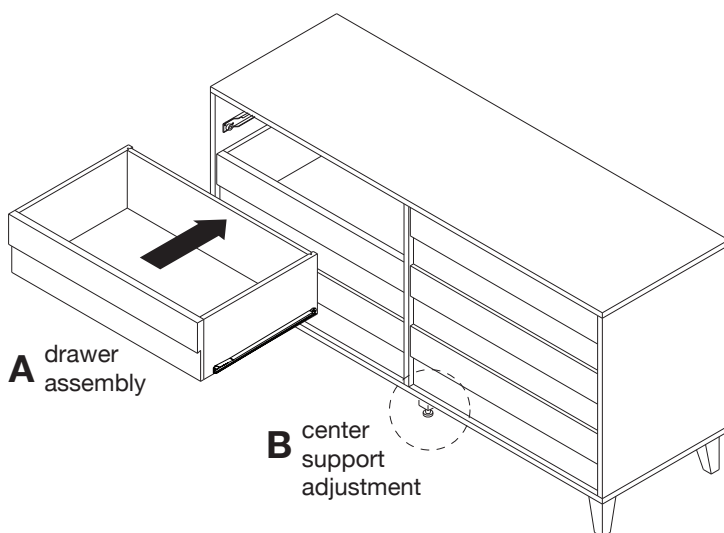

⑮ A) With the assistance of another adult, position unit upright as shown. Fit drawer glide wheels over wheels on the cabinet glides and push in while lifting slightly.
B) Adjust floor glide on **center support** leg until it hits the floor.
Assembly is now complete.

CLEANING AND CARE

Clean surfaces with a dry or damp soft cloth. Do not use abrasive cleaners. Do not use furniture wax or polish as the wood is finished with a protective clear lacquer.