

Thank you for purchasing the **Form Chair**. This page lists all the contents included in the box. Please take time to identify the hardware as well as the individual components of this product. As you unpack and prepare for assembly, place the contents on a carpeted or padded area to protect them from damage.

## HARDWARE



Missing hardware? Please call **800.606.6387** for replacements.

## TOOLS REQUIRED

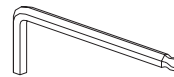

allen wrench  
(included)

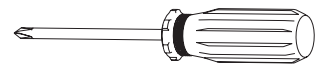

phillips head screwdriver

(We recommend the use of hand tools instead of power tools)

## COMPONENTS

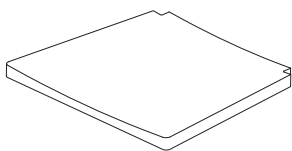

1 - seat

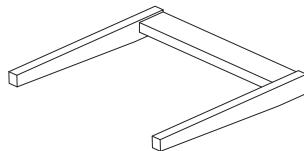

1 - front leg frame

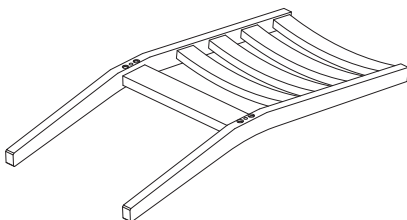

1 - back frame

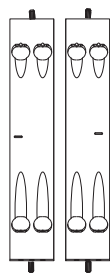

2 - side rails  
(1 left, 1 right)

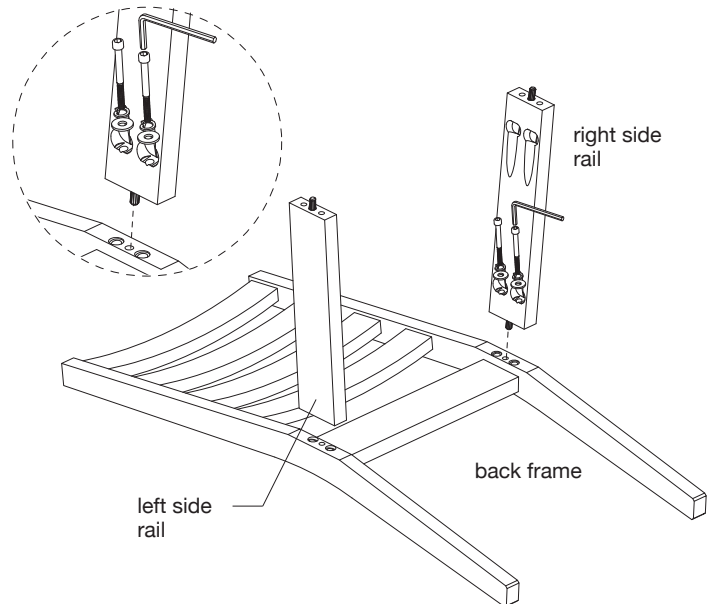

- 1 Place **back frame** onto a clean, padded surface. Fit pre-assembled dowels of **left and right side rails** into corresponding holes of **back frame**. Secure **left and right side rails** to **back frame** with 2 **flat washers**, 2 **spring washers** and 2 **bolts** per rail as shown, using an **allen wrench**. Do not over tighten the bolts.

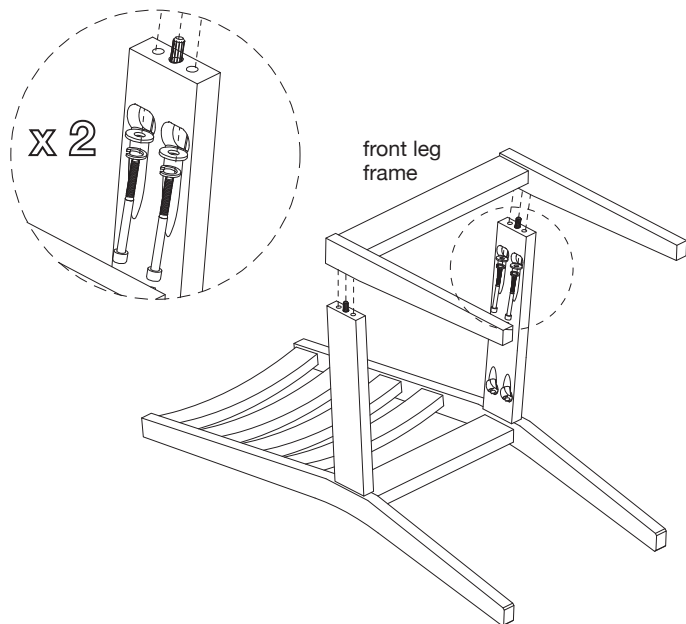

- ② Fit pre-assembled dowels of **left and right side rails** into corresponding holes of **front leg frame**. Secure **front leg frame to left and right side rails** with 2 **flat washers**, 2 **spring washers** and 2 **bolts** per side as shown.

NOTE: Do not over tighten the screws

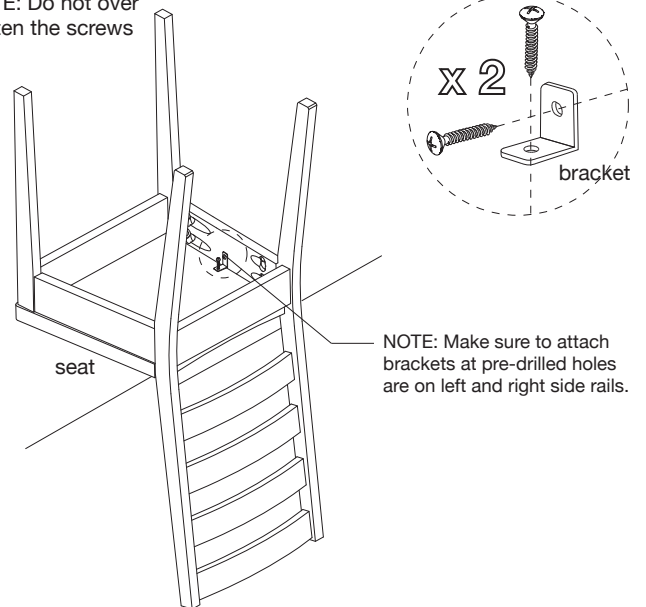

- ③ Attach **seat** to assembled unit with 2 **brackets**. Secure each **bracket** with 2 **screws** as shown, using a phillips head screwdriver. Make sure to attach bracket where pre-drilled holes are on left and right side rails. Do not over tighten the screws. Position assembled unit upright. Assembly is now complete.

## CLEANING AND CARE

Clean surfaces with a dry or damp soft cloth. Do not use abrasive cleaners. Periodically tighten bolts as necessary.